



**THE DATASHEET OF
AD8207WBRZ**



FEATURES

Ideal for current shunt applications

EMI filters included

1 $\mu\text{V}/^\circ\text{C}$ maximum input offset drift

High common-mode voltage range

–4 V to +65 V operating (5 V supply)

–4 V to +35 V operating (3.3 V supply)

–25 V to +75 V survival

Gain = 20 V/V

3.3 V to 5.5 V supply range

Wide operating temperature range: -40°C to $+125^\circ\text{C}$

Bidirectional current monitoring

<500 nV/ $^\circ\text{C}$ typical offset drift

<10 ppm/ $^\circ\text{C}$ typical gain drift

>90 dB CMRR dc to 10 kHz

Qualified for automotive applications

APPLICATIONS

High-side current sensing in

Motor control

Solenoid control

Engine management

Electric power steering

Suspension control

Vehicle dynamic control

DC-to-DC converters

GENERAL DESCRIPTION

The AD8207 is a single-supply difference amplifier ideal for amplifying small differential voltages in the presence of large common-mode voltage. The operating input common-mode voltage range extends from -4 V to $+65\text{ V}$ with a 5 V supply. The AD8207 works with a single-supply voltage of 3.3 V to 5 V, and is ideally suited to withstand large input PWM common-mode voltages, typical in solenoid and motor control applications.

The AD8207 is available in an 8-lead SOIC package. Excellent dc performance over temperature keeps errors in the measurement loop to a minimum. Offset drift is typically less than 500 nV/ $^\circ\text{C}$, and gain drift is typically below 10 ppm/ $^\circ\text{C}$.

FUNCTIONAL BLOCK DIAGRAM

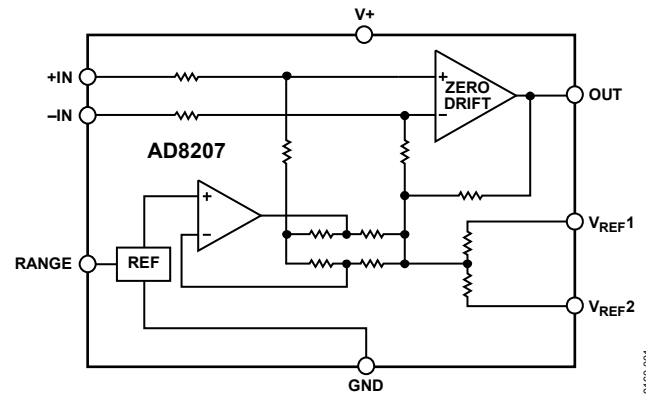

Figure 1.

05160-001

The AD8207 is ideal for bidirectional current sensing applications. It features two reference pins, V_{REF1} and V_{REF2} , that allow the user to easily offset the output of the device to any voltage within the supply range. With V_{REF1} attached to the $V+$ pin and V_{REF2} attached to the GND pin, the output is set at half scale. Attaching both pins to GND causes the output to be unipolar, starting near ground. Attaching both pins to $V+$ causes the output to be unipolar starting near $V+$. Other output offsets are achieved by applying an external low impedance voltage to the V_{REF1} and V_{REF2} pins.

Rev. 0

Information furnished by Analog Devices is believed to be accurate and reliable. However, no responsibility is assumed by Analog Devices for its use, nor for any infringements of patents or other rights of third parties that may result from its use. Specifications subject to change without notice. No license is granted by implication or otherwise under any patent or patent rights of Analog Devices. Trademarks and registered trademarks are the property of their respective owners.

TABLE OF CONTENTS

Features	1	Output Offset Adjustment	12
Applications.....	1	Unidirectional Operation.....	12
Functional Block Diagram	1	Bidirectional Operation.....	12
General Description	1	External Referenced Output	13
Revision History	2	Splitting the Supply	13
Specifications.....	3	Splitting an External Reference	13
Absolute Maximum Ratings.....	4	Applications Information	14
ESD Caution.....	4	Motor Control.....	14
Pin Configuration and Function Descriptions.....	5	Solenoid Control	15
Typical Performance Characteristics	6	Outline Dimensions	16
Theory of Operation	10	Ordering Guide	16
Power Supply Adjustment	11	Automotive Products.....	16
3.3 V to 4.5 V Supply Operation	11		
4.5 V to 5.5 V Supply Operation	11		

REVISION HISTORY

7/10—Revision 0: Initial Version

SPECIFICATIONS

$T_{OPR} = -40^{\circ}\text{C}$ to $+125^{\circ}\text{C}$, $V_{+} = 5\text{ V}$ or 3.3 V , unless otherwise noted.

Table 1.

Parameter	Min	Typ	Max	Unit	Test Conditions/Comments
GAIN					
Initial		20		V/V	
Accuracy over Temperature	-0.3		+0.3	%	T_{OPR}
Gain vs. Temperature	-15		0	ppm/ $^{\circ}\text{C}$	T_{OPR}
VOLTAGE OFFSET					
Offset Voltage (RTI) ¹		± 100		μV	25°C
Over Temperature (RTI) ¹			± 400	μV	T_{OPR}
Offset Drift	-1		+1	$\mu\text{V}/^{\circ}\text{C}$	T_{OPR}
INPUT					
Input Impedance					
Differential		240		k Ω	
Common Mode		126		k Ω	
Input Voltage Range	-4		+65	V	Common mode, continuous, $V_{+} = 5\text{ V}$, T_{OPR}
	-4		+35	V	Common mode continuous, $V_{+} = 3.3\text{ V}$, T_{OPR}
		250		mV	Differential ² , $V_{+} = 5\text{ V}$
Common-Mode Rejection (CMRR)	80	90		dB	T_{OPR} , $f = \text{dc}$ to 20 kHz
OUTPUT					
Output Voltage Range	0.02		$V_{+} - 0.05$	V	$R_L = 25\text{ k}\Omega$, T_{OPR}
Output Resistance		2		Ω	
DYNAMIC RESPONSE					
Small-Signal -3 dB Bandwidth		150		kHz	T_{OPR}
Slew Rate		1		V/ μs	
NOISE					
0.1 Hz to 10 Hz, (RTI) ¹		20		$\mu\text{V p-p}$	
Spectral Density, 1 kHz, (RTI) ¹		0.6		$\mu\text{V}/\sqrt{\text{Hz}}$	
OFFSET ADJUSTMENT					
Ratiometric Accuracy ³	0.497		0.503	V/V	Divider to supplies, T_{OPR}
Accuracy (RTO) ⁴			± 3	mV/V	Voltage applied to V_{REF1} and V_{REF2} in parallel, T_{OPR}
Output Offset Adjustment Range	0.02		$V_{+} - 0.05$	V	T_{OPR}
V_{REF} Input Voltage Range ⁵	0.0		V_{+}	V	
V_{REF} Divider Resistor Values		100		k Ω	
POWER SUPPLY					
Operating Range	4.5		5.5	V	RANGE (Pin 4) connected to GND ⁶
	3.3		4.5	V	RANGE (Pin 4) connected to V_{+} ⁷
Quiescent Current over Temperature			2.5	mA	$V_O = 0.1\text{ V dc}$
Power Supply Rejection Ratio (PSRR)	80			dB	
TEMPERATURE RANGE					
For Specified Performance	-40		+125	$^{\circ}\text{C}$	

¹ RTI = referred to input.

² Input voltage range = $\pm 125\text{ mV}$ with half-scale offset. The input differential range also depends on the supply voltage. The maximum input differential range can be calculated by $V_{+}/20$.

³ The offset adjustment is ratiometric to the power supply when V_{REF1} and V_{REF2} are used as a divider between the supplies.

⁴ RTO = referred to output.

⁵ The reference pins should be driven with a low impedance voltage source to maintain the specified accuracy of the AD8207.

⁶ With a 4.5 V to 5.5 V supply, the RANGE pin should be tied low. In this mode, the common-mode range of the AD8207 is -4 V to +65 V.

⁷ With a 3.3 V to 4.5 V supply, the RANGE pin should be tied to V_{+} . In this mode, the common-mode range of the AD8207 is -4 V to +35 V. If a 4.5 V supply is used, the user can tie RANGE high or low depending on the common-mode range needed in the application.

ABSOLUTE MAXIMUM RATINGS

Table 2.

Parameter	Rating
Supply Voltage	12.5 V
Continuous Input Voltage	–25 V to +75 V
Input Transient Survival	–30 V to +80 V
Differential Input Voltage	–25 V to +75 V
Reverse Supply Voltage	0.3 V
Operating Temperature Range	–40°C to +125°C
Storage Temperature Range	–65°C to +150°C
Output Short-Circuit Duration	Indefinite

Stresses above those listed under Absolute Maximum Ratings may cause permanent damage to the device. This is a stress rating only and functional operation of the device at these or any other conditions above those indicated in the operational section of this specification is not implied. Exposure to absolute maximum rating conditions for extended periods may affect device reliability.

ESD CAUTION



ESD (electrostatic discharge) sensitive device. Charged devices and circuit boards can discharge without detection. Although this product features patented or proprietary protection circuitry, damage may occur on devices subjected to high energy ESD. Therefore, proper ESD precautions should be taken to avoid performance degradation or loss of functionality.

PIN CONFIGURATION AND FUNCTION DESCRIPTIONS

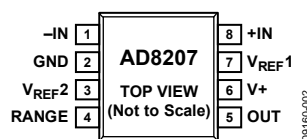

Figure 2. Pin Configuration

Table 3. Pin Function Descriptions

Pin No.	Mnemonic	Description
1	-IN	Negative Input.
2	GND	Ground Pin.
3	V_{REF2}	Reference Input.
4	RANGE	Range Pin. This pin switches between 4.5 V to 5.5 V and 3.3 V to 4.5 V supply operation.
5	OUT	Output.
6	V+	Supply Pin.
7	V_{REF1}	Reference Input.
8	+IN	Positive Input.

TYPICAL PERFORMANCE CHARACTERISTICS

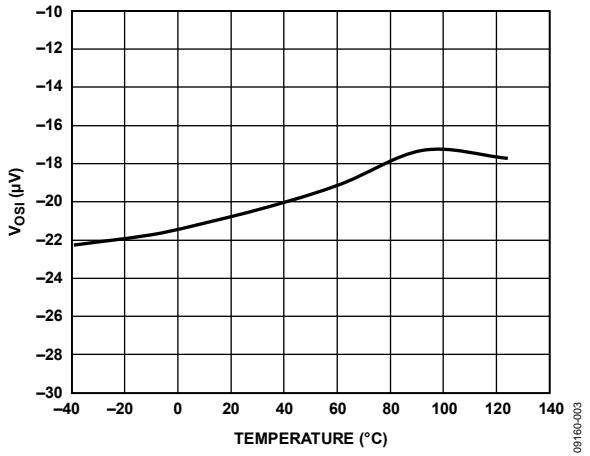

Figure 3. Typical Offset Drift vs. Temperature

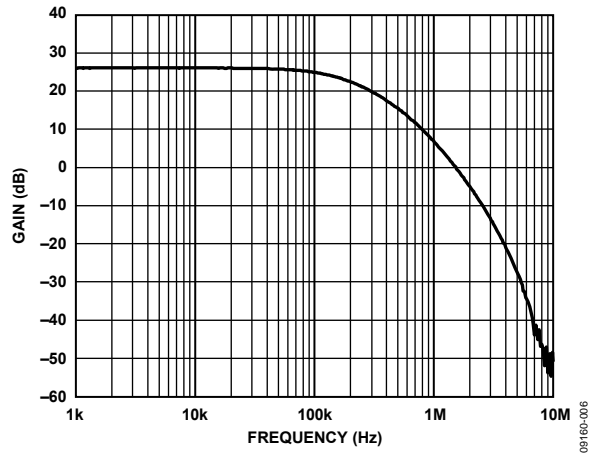

Figure 6. Typical Small-Signal Bandwidth ($V_{OUT} = 200 \text{ mV p-p}$)

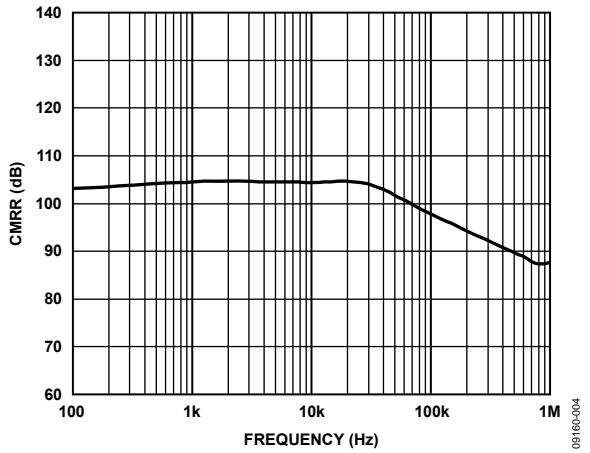

Figure 4. Typical CMRR vs. Frequency

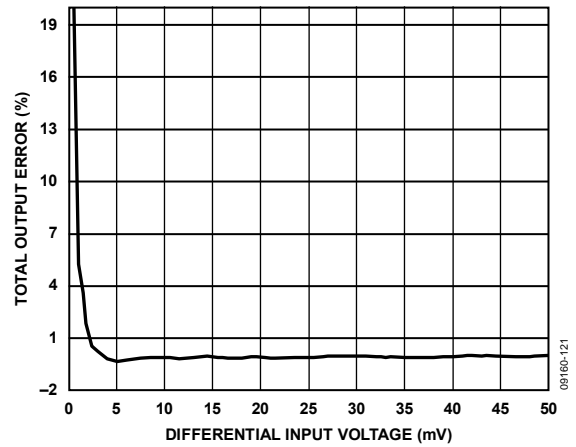

Figure 7. Total Output Error vs. Differential Input Voltage

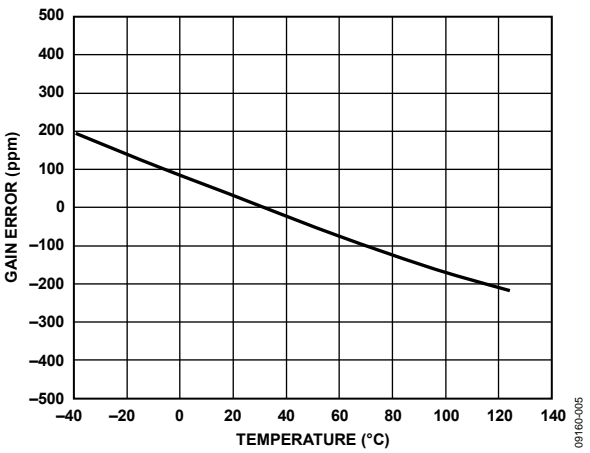

Figure 5. Typical Gain Error vs. Temperature

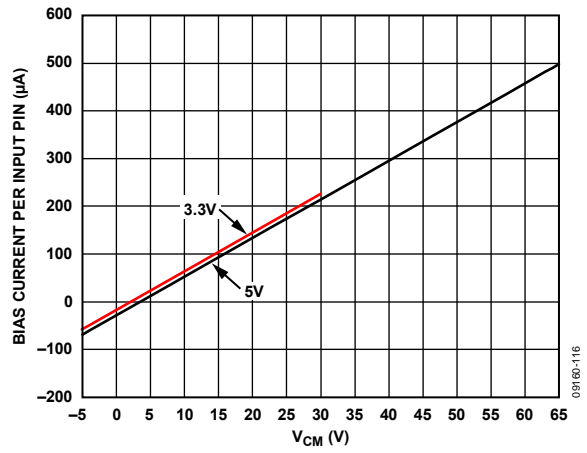

Figure 8. Input Bias Current vs. Common-Mode Voltage

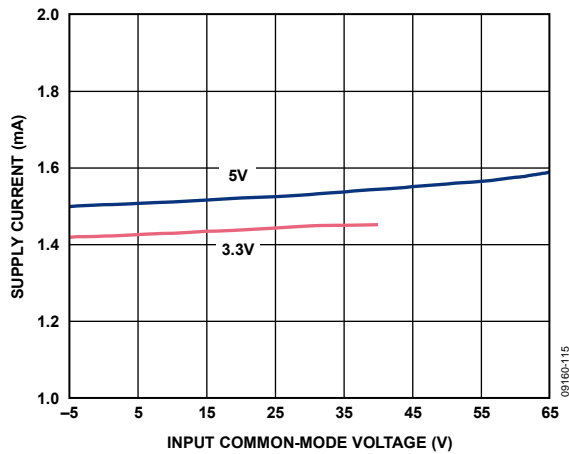

Figure 9. Supply Current vs. Input Common-Mode Voltage

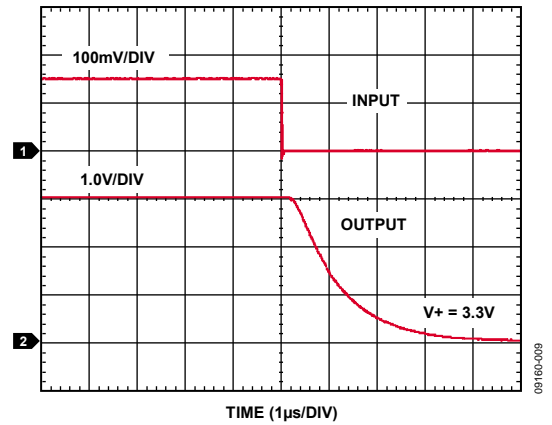

Figure 12. Fall Time ($V^+ = 3.3\text{ V}$)

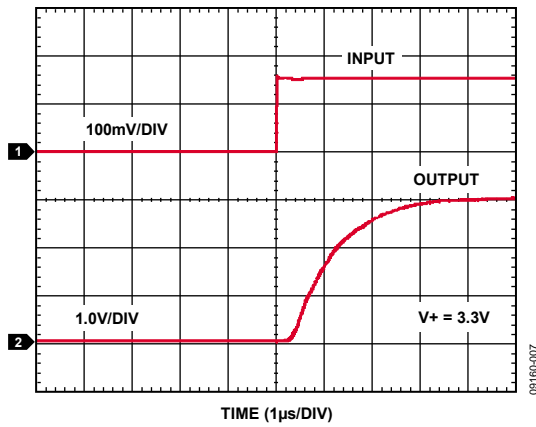

Figure 10. Rise Time ($V^+ = 3.3\text{ V}$)

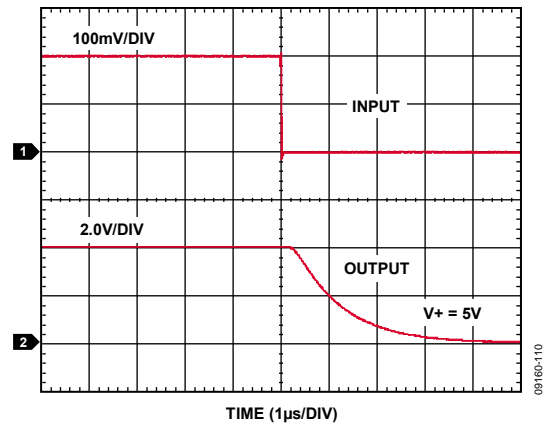

Figure 13. Fall Time ($V^+ = 5\text{ V}$)

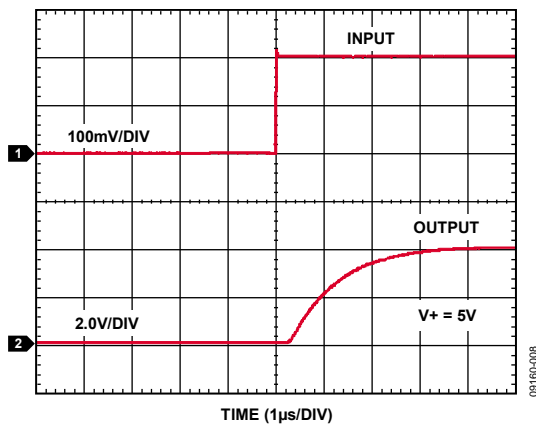

Figure 11. Rise Time ($V^+ = 5\text{ V}$)

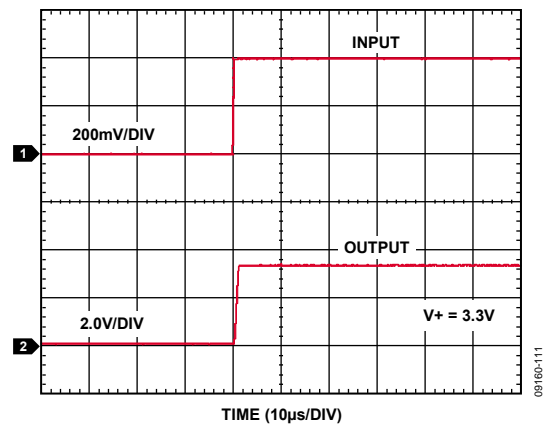

Figure 14. Differential Overload Recovery, Rising ($V^+ = 3.3\text{ V}$)

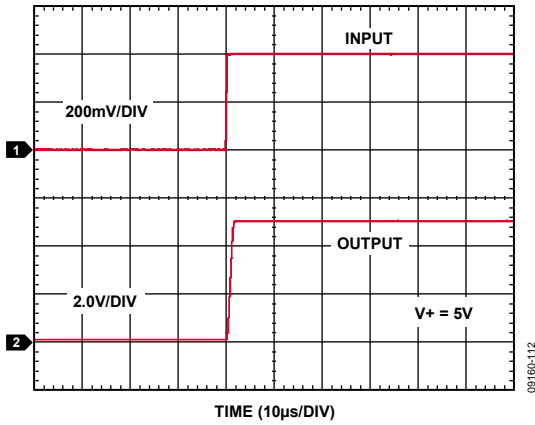

Figure 15. Differential Overload Recovery, Rising ($V+ = 5V$)

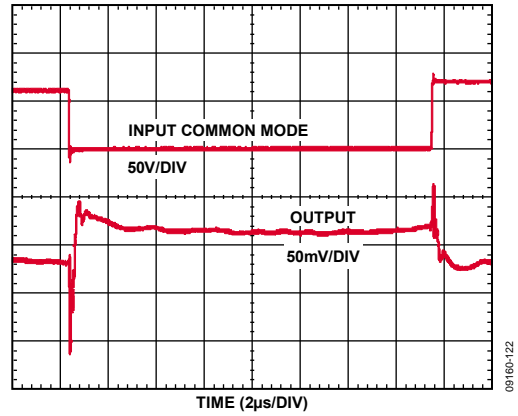

Figure 18. Input Common-Mode Step Response ($V+ = 5V$, Inputs Shorted)

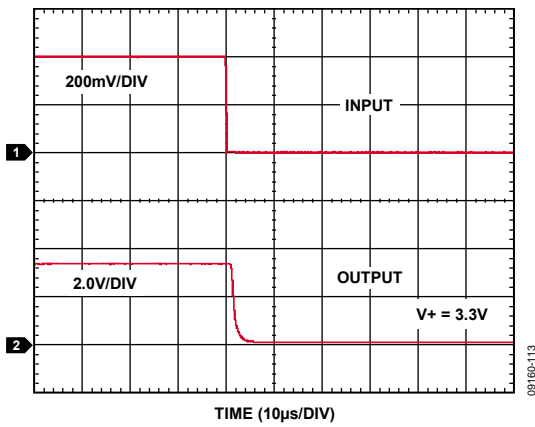

Figure 16. Differential Overload Recovery, Falling ($V+ = 3.3V$)

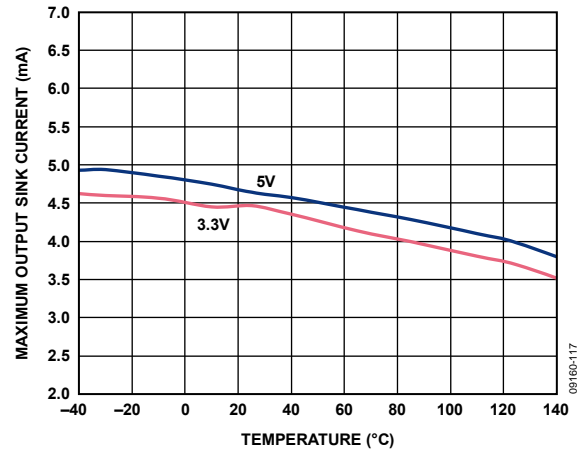

Figure 19. Maximum Output Sink Current vs. Temperature

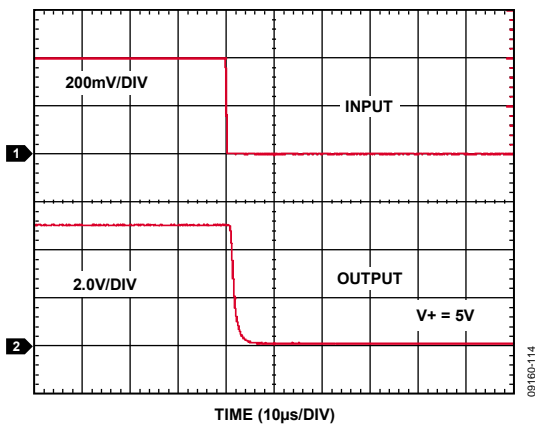

Figure 17. Differential Overload Recovery, Falling ($V+ = 5V$)

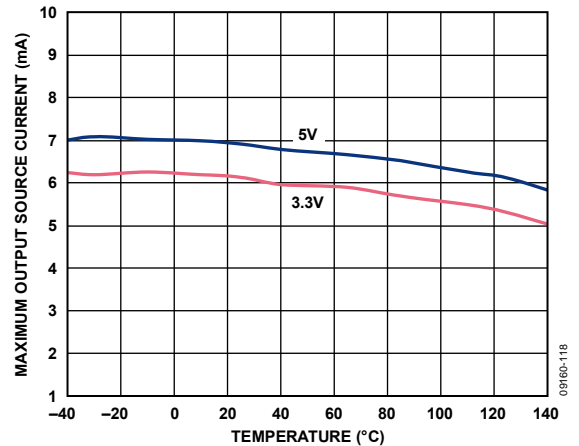

Figure 20. Maximum Output Source Current vs. Temperature

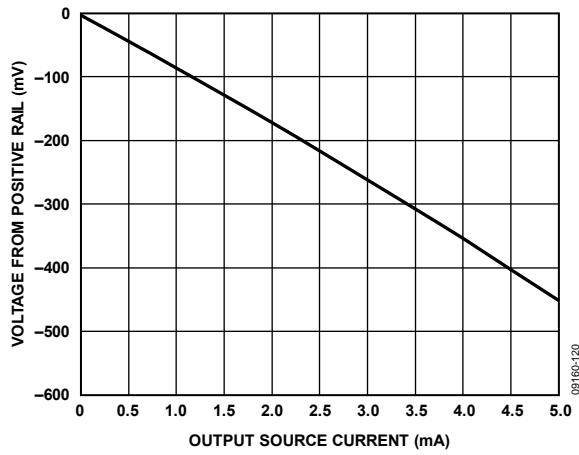

Figure 21. Output Voltage Range vs. Output Source Current

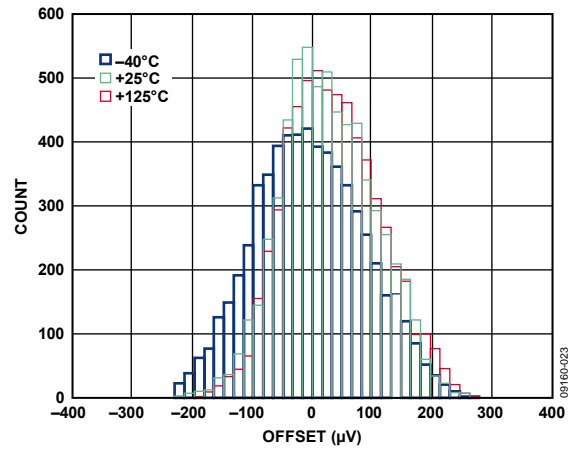

Figure 23. Input Offset Distribution

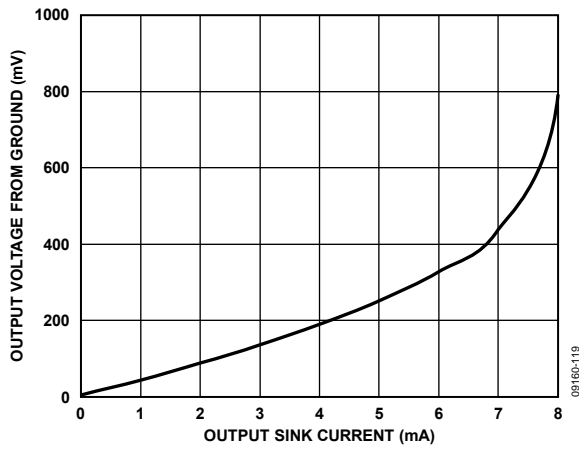

Figure 22. Output Voltage Range from GND vs. Output Sink Current

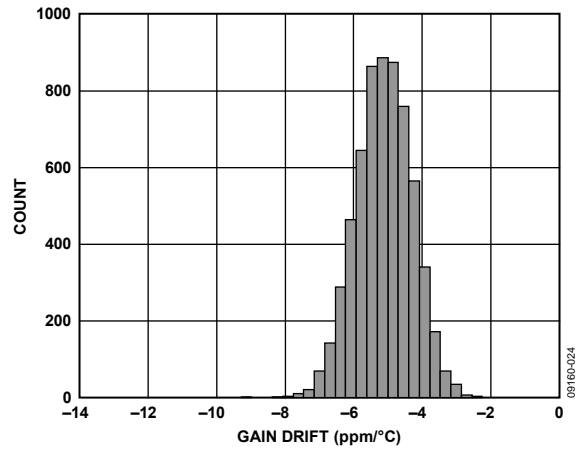

Figure 24. Gain Drift Distribution

THEORY OF OPERATION

The AD8207 is a single-supply, zero drift, difference amplifier that uses a unique architecture to accurately amplify small differential current shunt voltages in the presence of rapidly changing common-mode voltage.

In typical applications, the AD8207 is used to measure current by amplifying the voltage across a shunt resistor connected to its inputs.

The AD8207 includes a zero-drift amplifier, a precision resistor network, a common-mode control amplifier, and a precision reference (see Figure 25).

A set of precision-trimmed resistors make up the network that attenuates the input common-mode voltage to within the supply range of the amplifier, in this case with a ratio of 20/1. This attenuation ensures that when the input pins are externally at the common-mode extremes of -4 V and $+65\text{ V}$, the actual voltage at the inputs of the main amplifier is still within the supply range.

The input resistor network also attenuates normal (differential) mode voltages. Therefore, the total internal gain of the AD8207 is set to 400 V/V to provide a total system gain of 20 V/V.

$$\text{Total Gain (V/V)} = 1/20 \text{ (V/V)} \times 400 \text{ (V/V)} = 20 \text{ V/V}$$

The AD8207 is designed to provide excellent common-mode rejection, even with PWM common-mode inputs that can change at very fast rates, for example, 1 V/ns . An internal common-mode control amplifier is used to maintain the input common mode of the main amplifier at 3.5 V (with 5 V supply), and therefore eliminates the negative effects of such fast-changing external common-mode variations.

The AD8207 features an input offset drift of less than $500\text{ nV/}^\circ\text{C}$. This performance is achieved through a novel zero-drift architecture that does not compromise bandwidth, which is typically rated at 150 kHz .

The reference inputs, V_{REF1} and V_{REF2} , are tied through $100\text{ k}\Omega$ resistors to the positive input of the main amplifier, which allows the output offset to be adjusted anywhere in the output operating range. The gain is 1 V/V from the reference pins to the output when the reference pins are used in parallel. When the pins are used to divide the supply, the gain is 0.5 V/V .

The AD8207 offers breakthrough performance without compromising any of the robust application needs typical of solenoid or motor control. The part rejects PWM input common-mode voltages, while the zero-drift architecture yields the lowest offset and offset drift performance on the market.

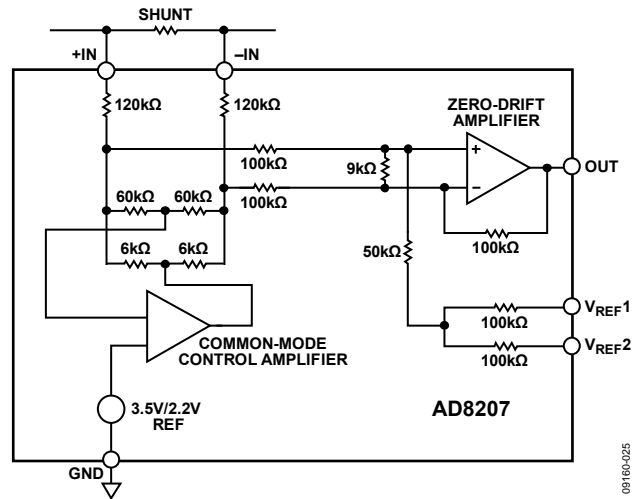

Figure 25. Simplified Schematic

POWER SUPPLY ADJUSTMENT

3.3 V TO 4.5 V SUPPLY OPERATION

The AD8207 can operate with a single-supply voltage as low as 3.3 V to 4.5 V. This mode of operation is achieved by connecting the RANGE pin (Pin 4) to the supply (see Figure 26). It is recommended that an external resistor be placed in series from the RANGE pin to the supply. This resistor can be a typical 5 k Ω 1% resistor.

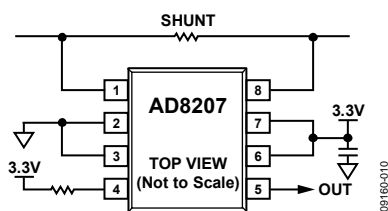

Figure 26. 3.3 V Supply Operation

Note that in this mode of operation, the common-mode range of the AD8207 is limited to -4 V to $+35$ V. The output and reference input ranges are limited to the supply of the part. The user can have a 4.5 V supply and connect the RANGE pin from 3.3 V to 4.5 V. Alternatively, the user can connect the RANGE pin as high as 4.5 V, with the supply from 3.3 V to 4.5 V.

4.5 V TO 5.5 V SUPPLY OPERATION

In most applications, the AD8207 operates with a single 5 V supply. In this mode, the operating input common-mode range of the AD8207 is rated from -4 V to $+65$ V. To operate the device with a 5 V supply (includes 4.5 V to 5.5 V), connect the RANGE pin (Pin 4) to logic low, or GND, as shown in Figure 27.

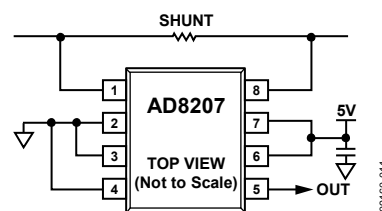

Figure 27. 5 V Supply Bidirectional Operation

The output and reference input ranges are limited to the supply voltage used. With a supply voltage from 4.5 V to 5.5 V, the RANGE pin (Pin 4) should be connected to GND to achieve the maximum input common-mode range specification of -4 V to $+65$ V.

OUTPUT OFFSET ADJUSTMENT

The output of the AD8207 can be adjusted for unidirectional or bidirectional operation.

UNIDIRECTIONAL OPERATION

Unidirectional operation allows the AD8207 to measure currents through a resistive shunt in one direction. The basic modes for unidirectional operation are ground referenced output mode and V+ referenced output mode.

For unidirectional operation, the output can be set at the negative rail (near ground) or at the positive rail (near V+) when the differential input is 0 V. The output moves to the opposite rail when a correct polarity differential input voltage is applied. In this case, full scale is approximately 250 mV for a 5 V supply or 165 mV for a 3.3 V supply. The required polarity of the differential input depends on the output voltage setting. If the output is set at the positive rail, the input polarity must be negative to move the output down. If the output is set at ground, the polarity must be positive to move the output up.

Ground Referenced Output Mode

When using the AD8207 in the ground referenced output mode, both reference inputs are tied to ground, which causes the output to sit at the negative rail when there are 0 differential volts at the input (see Figure 28).

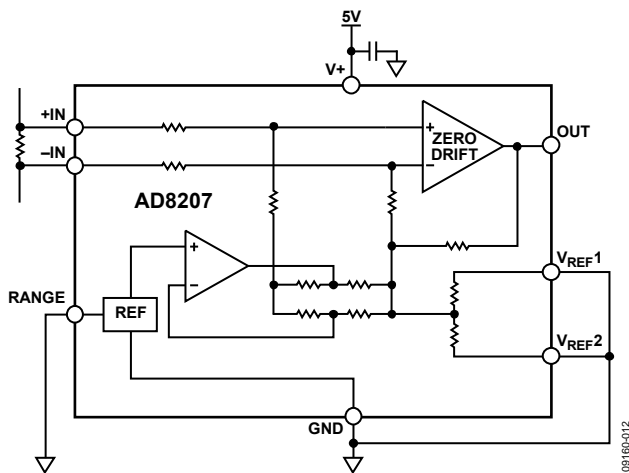

Figure 28. Ground Referenced Output Mode, V+ = 5 V

Table 4. Ground Referenced Output

V _{IN} (Referred to -IN)	V _O
V+ = 5 V	
0 V	0.02 V
250 mV	4.95 V
V+ = 3.3 V	
0 V	0.02 V
165 mV	3.25 V

V+ Referenced Output Mode

The V+ referenced output mode is set when both reference pins are tied to the positive supply. This mode is typically used when the diagnostic scheme requires detection of the amplifier and the wiring before power is applied to the load (see Figure 29).

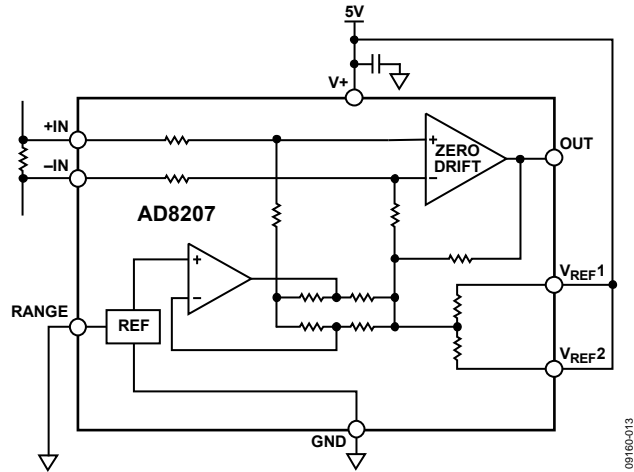

Figure 29. V+ Referenced Output Mode, V+ = 5 V

Table 5. V+ Referenced Output

V _{IN} (Referred to -IN)	V _O
V+ = 5 V	
0 V	4.95 V
-250 mV	0.02 V
V+ = 3.3 V	
0 V	3.25 V
-165 mV	0.02 V

BIDIRECTIONAL OPERATION

Bidirectional operation allows the AD8207 to measure currents through a resistive shunt in two directions. In this case, the output is set anywhere within the output range. Typically, it is set at half scale for equal range in both directions. In some cases, however, it is set at a voltage other than half scale when the bidirectional current is asymmetrical.

Table 6. V_O = (V+/2) with V_{IN} = 0 V

V _{IN} (Referred to -IN)	V _O
V+ = 5 V	
+100 mV	4.5 V
-100 mV	0.5 V
V+ = 3.3 V	
+67.5 mV	3 V
-67.5 mV	0.3 V

Adjusting the output is accomplished by applying voltages to the reference inputs. V_{REF1} and V_{REF2} are tied to internal resistors that connect to an internal offset node. There is no operational difference between the pins.

EXTERNAL REFERENCED OUTPUT

Tying both reference pins together and to an external reference produces an output equal to the reference voltage when there is no differential input (see Figure 30). The output moves down from the reference voltage when the input is negative, relative to the $-IN$ pin, and up when the input is positive, relative to the $-IN$ pin. The reference pins are connected to the positive input of the main amplifier via precision-trimmed $100\text{ k}\Omega$ resistors. Therefore, it is recommended that a low impedance voltage is always be used to set the reference voltage. If external resistors are connected directly to the V_{REF1} and V_{REF2} pins, there will be a mismatch with the internal trimmed resistors, leading to offset gain accuracy reduction.

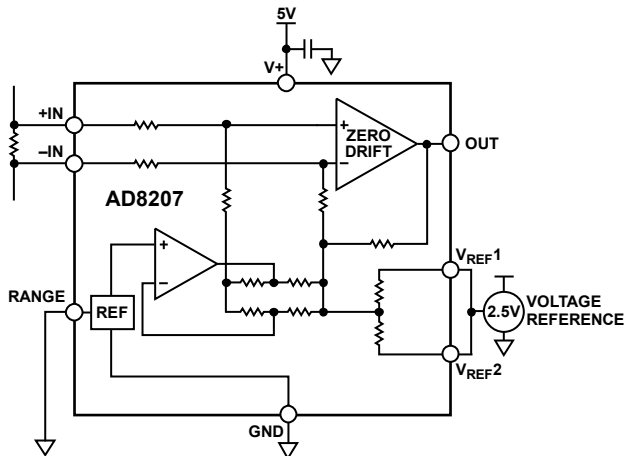

Figure 30. External Referenced Output, $V_+ = 5\text{ V}$

SPLITTING THE SUPPLY

By tying one reference pin to V_+ and the other to the ground pin, the output is set at half of the supply when there is no differential input (see Figure 31). The benefit is that no external reference is required to offset the output for bidirectional current measurement. This creates a midscale offset that is ratiometric to the supply, which means that if the supply increases or decreases, the output remains at half the supply. For example, if the supply is 5.0 V , the output is at half scale, or 2.5 V . If the supply increases by 10% (to 5.5 V), the output goes to 2.75 V .

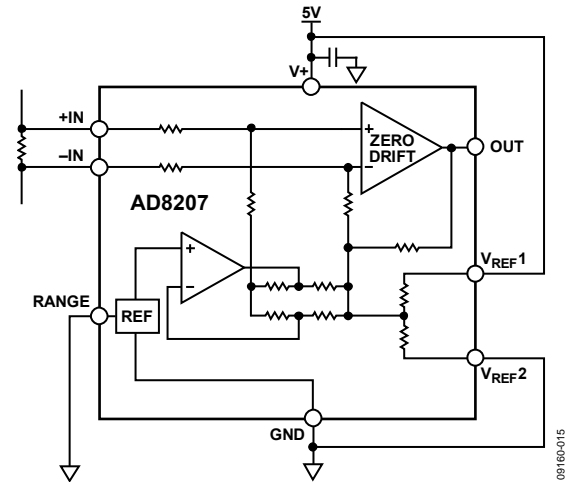

Figure 31. Splitting the Supply, $V_+ = 5\text{ V}$

SPLITTING AN EXTERNAL REFERENCE

In Figure 32, an external reference is divided by 2 with an accuracy of approximately 0.5% by connecting one V_{REF} pin to ground and the other V_{REF} pin to the reference (see Figure 32).

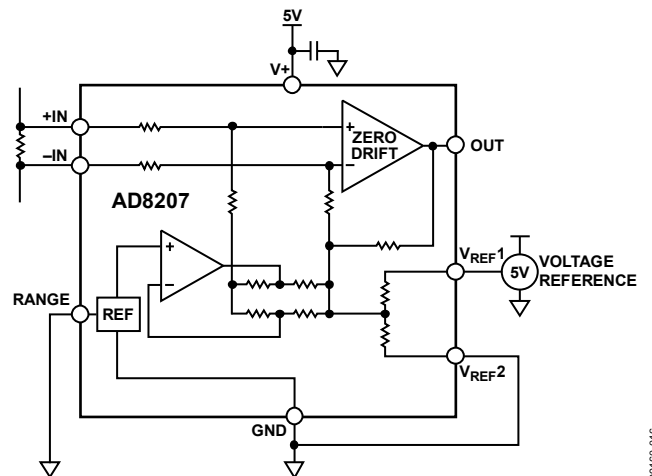

Figure 32. Splitting an External Reference, $V_+ = 5\text{ V}$

APPLICATIONS INFORMATION

MOTOR CONTROL

3-Phase Motor Control

The AD8207 is ideally suited for monitoring current in 3-phase motor applications.

The 150 kHz typical bandwidth of the AD8207 allows for instantaneous current monitoring. Additionally, the typical low offset drift of 500 nV/°C means that the measurement error between the two motor phases will be at a minimum over temperature. The AD8207 rejects PWM input common-mode voltages in the range of -4 V to $+65\text{ V}$ (with a 5 V supply). Monitoring the current on the motor phase allows for sampling of the current at any point and allows for diagnostic information such as a short to GND and battery. Refer to Figure 34 for a typical phase current measurement setup with the AD8207.

H-Bridge Motor Control

Another typical application for the AD8207 is as part of the control loop in H-bridge motor control. In this case, the shunt resistor is placed in the middle of the H-bridge (see Figure 33) so that it can accurately measure current in both

directions by using the shunt available at the motor. This is a better solution than a ground referenced op amp because ground is not typically a stable reference voltage in this type of application. The instability of the ground reference causes inaccuracies in the measurements that could be made with a simple ground referenced op amp. The AD8207 measures current in both directions as the H-bridge switches and the motor changes direction. The output of the AD8207 is configured in an external referenced bidirectional mode (see the Bidirectional Operation section).

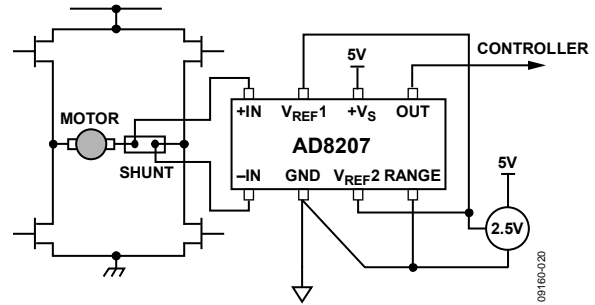

Figure 33. H-Bridge Motor Control Application

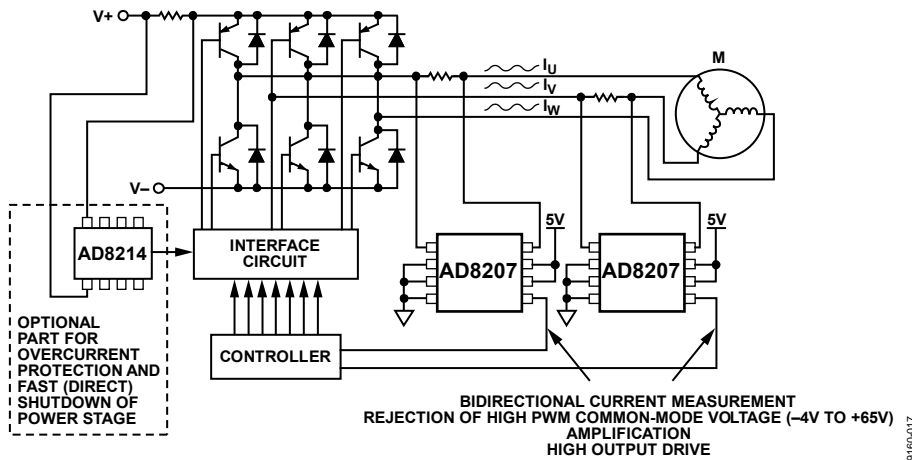

Figure 34. 3-Phase Motor Control

SOLENOID CONTROL

High-Side Current Sense with a Low-Side Switch

Other typical applications for the AD8207 include current monitoring for PWM control of solenoid openings. Typical applications include hydraulic valve control, diesel injection control, and actuator control.

In Figure 35, the PWM control switch is ground referenced. An inductive load (solenoid) is tied to a power supply. A resistive shunt is placed between the switch and the load (see Figure 35). An advantage of placing the shunt on the high side is that the entire current, including the recirculation current, can be measured because the shunt remains in the loop when the switch is off. In addition, diagnostics capabilities are enhanced because shorts to ground can be detected with the shunt on the high side. In this circuit configuration, when the switch is closed, the common-mode voltage moves down to near the negative rail. When the switch is opened, the voltage reversal across the inductive load causes the common-mode voltage to be held one diode drop above the battery by the clamp diode.

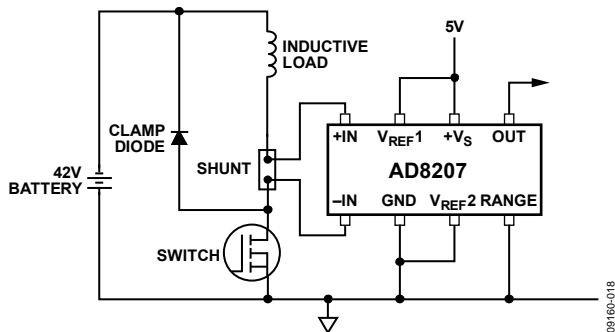

Figure 35. Low-Side Switch

High-Side Current Sense with a High-Side Switch

This configuration minimizes the possibility of unexpected solenoid activation and excessive corrosion (see Figure 36). In Figure 36, both the switch and the shunt are on the high side. When the switch is off, the battery is removed from the load, which prevents damage from potential shorts to ground, while still allowing the recirculation current to be measured and providing for diagnostics. Removing the power supply from the load for the majority of the time minimizes the corrosive effects that can be caused by the differential voltage between the load and ground. When using a high-side switch, the battery voltage is connected to the load when the switch is closed, causing the common-mode voltage to increase to the battery voltage. When the switch is opened, the voltage reversal across the inductive load causes the common-mode voltage to be held one diode drop below ground by the clamp diode.

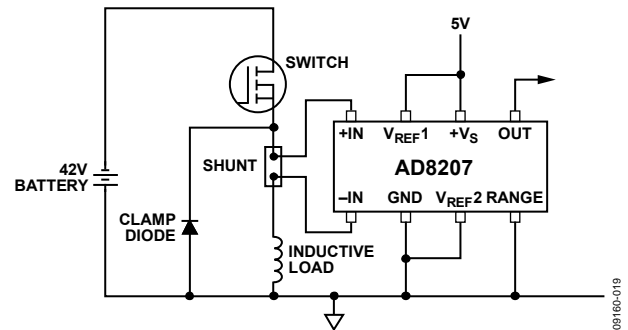
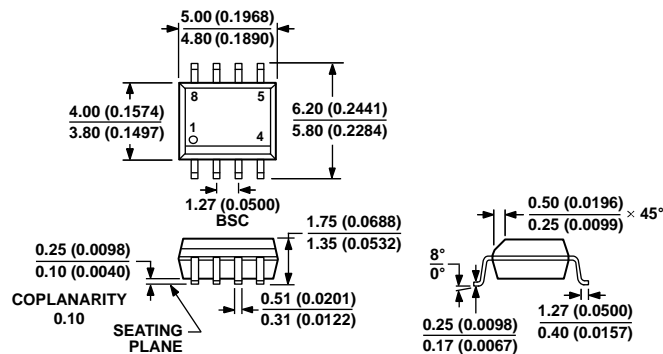

Figure 36. High-Side Switch

OUTLINE DIMENSIONS



COMPLIANT TO JEDEC STANDARDS MS-012-AA
 CONTROLLING DIMENSIONS ARE IN MILLIMETERS; INCH DIMENSIONS
 (IN PARENTHESES) ARE ROUNDED-OFF MILLIMETER EQUIVALENTS FOR
 REFERENCE ONLY AND ARE NOT APPROPRIATE FOR USE IN DESIGN.

012407-A

Figure 37. 8-Lead Standard Small Outline Package [SOIC_N]
 Narrow Body (R-8)
 Dimensions shown in millimeters and (inches)

ORDERING GUIDE

Model ^{1,2}	Temperature Range	Package Description	Package Option
AD8207WBRZ	-40°C to +125°C	8-Lead SOIC_N	R-8
AD8207WBRZ-R7	-40°C to +125°C	8-Lead SOIC_N, 7" Tape and Reel	R-8
AD8207WBRZ-RL	-40°C to +125°C	8-Lead SOIC_N, 13" Tape and Reel	R-8

¹ Z = RoHS Compliant Part.

² W = Qualified for Automotive Applications.

AUTOMOTIVE PRODUCTS

The AD8207 models are available with controlled manufacturing to support the quality and reliability requirements of automotive applications. Note that these automotive models may have specifications that differ from the commercial models; therefore, designers should review the Specifications section of this data sheet carefully. Only the automotive grade products shown are available for use in automotive applications. Contact your local Analog Devices account representative for specific product ordering information and to obtain the specific Automotive Reliability reports for these models.

Looking for pricing, stock, or lifecycle information?

Click below to explore more details on WIN SOURCE:

 [View AD8207WBRZ on WIN SOURCE](#)

 [Analog Devices Inc. Information](#)

Optimize Your Supply Chain with WIN SOURCE Solutions

-  Global Sourcing Solution
-  Obsolete Management
-  Cost Control Management
-  Shortage Management
-  Alternative Solution
-  Excess Inventory Management