



# THE DATASHEET OF STL8N65M5





# STL8N65M5

N-channel 650 V, 0.56  $\Omega$ , 7 A MDmesh™ V  
Power MOSFET in PowerFLAT™ 5x5

## Features

| Order code | V <sub>DSS</sub> @<br>T <sub>Jmax</sub> | R <sub>DS(on)</sub><br>max | I <sub>D</sub>     |
|------------|---|----------------------------|--------------------|
| STL8N65M5  | 710 V                                   | < 0.6 $\Omega$             | 7 A <sup>(1)</sup> |

1. The value is rated according to R<sub>thj-case</sub>

- Worldwide best R<sub>DS(on)</sub> \* area
- Higher V<sub>DSS</sub> rating
- High dv/dt capability
- Excellent switching performance
- Easy to drive
- 100% avalanche tested

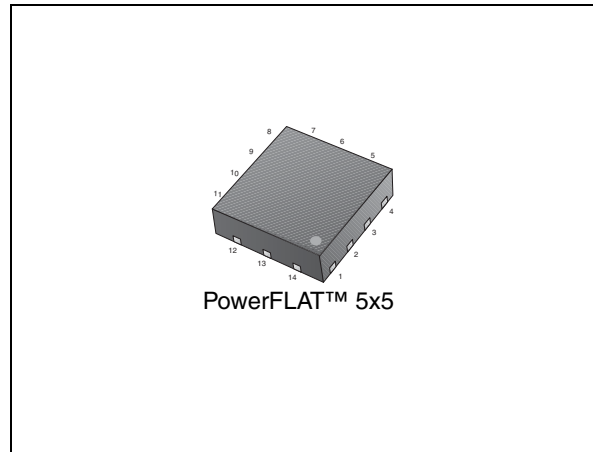

## Applications

- Switching applications

## Description

This device is an N-channel MDmesh™ V Power MOSFET based on an innovative proprietary vertical process technology, which is combined with STMicroelectronics' well-known PowerMESH™ horizontal layout structure. The resulting product has extremely low on-resistance, which is unmatched among silicon-based Power MOSFETs, making it especially suitable for applications which require superior power density and outstanding efficiency.

Figure 1. Internal schematic diagram

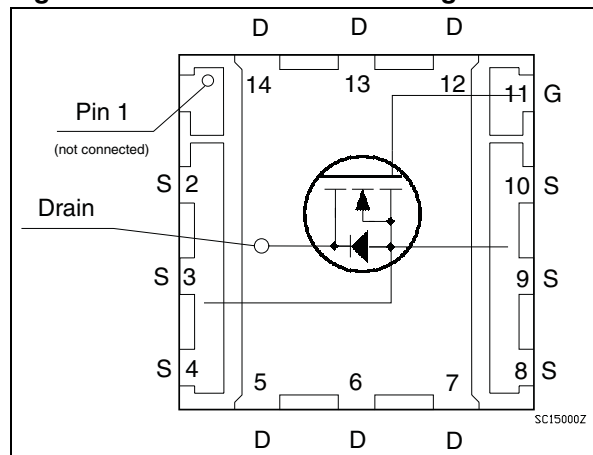

Table 1. Device summary

| Order code | Marking | Package        | Packaging     |
|------------|---------|----------------|---------------|
| STL8N65M5  | 8N65M5  | PowerFLAT™ 5x5 | Tape and reel |

# Contents

|          |   |           |
|----------|---|-----------|
| <b>1</b> | <b>Electrical ratings</b> .....               | <b>3</b>  |
| <b>2</b> | <b>Electrical characteristics</b> .....       | <b>4</b>  |
|          | 2.1 Electrical characteristics (curves) ..... | 6         |
| <b>3</b> | <b>Test circuits</b> .....                    | <b>8</b>  |
| <b>4</b> | <b>Package mechanical data</b> .....          | <b>9</b>  |
| <b>5</b> | <b>Revision history</b> .....                 | <b>12</b> |

# 1 Electrical ratings

**Table 2. Absolute maximum ratings**

| Symbol             | Parameter  | Value       | Unit             |
|--------------------|--|-------------|------------------|
| $V_{DS}$           | Drain-source voltage ( $V_{GS} = 0$ )  | 650         | V                |
| $V_{GS}$           | Gate-source voltage  | $\pm 25$    | V                |
| $I_D^{(1)}$        | Drain current (continuous) at $T_C = 25\text{ }^\circ\text{C}$   | 7           | A                |
| $I_D^{(1)}$        | Drain current (continuous) at $T_C = 100\text{ }^\circ\text{C}$  | 4.4         | A                |
| $I_D^{(2)}$        | Drain current (continuous) at $T_{amb} = 25\text{ }^\circ\text{C}$   | 1.4         | A                |
| $I_D^{(2)}$        | Drain current (continuous) at $T_{amb} = 100\text{ }^\circ\text{C}$  | 0.6         | A                |
| $I_{DM}^{(2),(3)}$ | Drain current (pulsed)   | 5.6         | A                |
| $P_{TOT}^{(2)}$    | Total dissipation at $T_{amb} = 25\text{ }^\circ\text{C}$  | 2.5         | W                |
| $P_{TOT}^{(1)}$    | Total dissipation at $T_C = 25\text{ }^\circ\text{C}$  | 70          | W                |
| $I_{AR}$           | Avalanche current, repetitive or not-repetitive (pulse width limited by $T_j$ max)                                   | 2           | A                |
| $E_{AS}$           | Single pulse avalanche energy (starting $T_j = 25\text{ }^\circ\text{C}$ , $I_D = I_{AR}$ , $V_{DD} = 50\text{ V}$ ) | 120         | mJ               |
| $dv/dt^{(4)}$      | Peak diode recovery voltage slope  | 15          | V/ns             |
| $T_{stg}$          | Storage temperature  | - 55 to 150 | $^\circ\text{C}$ |
| $T_j$              | Max. operating junction temperature  | 150         | $^\circ\text{C}$ |

1. The value is rated according to  $R_{thj-case}$
2. When mounted on FR-4 board of  $1\text{ inch}^2$ , 2oz Cu
3. Pulse with limited by safe operating area.
4.  $I_{SD} \leq 7\text{ A}$ ,  $di/dt \leq 400\text{ A}/\mu\text{s}$ ,  $V_{Peak} < V_{(BR)DSS}$ ,  $V_{DD} = 400\text{ V}$ .

**Table 3. Thermal data**

| Symbol              | Parameter                            | Value | Unit                      |
|---------------------|--------------------------------------|-------|---------------------------|
| $R_{thj-case}$      | Thermal resistance junction-case max | 1.78  | $^\circ\text{C}/\text{W}$ |
| $R_{thj-pcb}^{(1)}$ | Thermal resistance junction-pcb max  | 60    | $^\circ\text{C}/\text{W}$ |

1. When mounted on  $1\text{ inch}^2$  FR-4 board, 2 oz Cu

## 2 Electrical characteristics

( $T_C = 25\text{ °C}$  unless otherwise specified)

**Table 4. On /off states**

| Symbol        | Parameter  | Test conditions   | Min. | Typ. | Max.     | Unit                           |
|---------------|--|---|------|------|----------|--------------------------------|
| $V_{(BR)DSS}$ | Drain-source breakdown voltage ( $V_{GS} = 0$ )  | $I_D = 1\text{ mA}$   | 650  |      |          | V                              |
| $I_{DSS}$     | Zero gate voltage drain current ( $V_{GS} = 0$ ) | $V_{DS} = 650\text{ V}$<br>$V_{DS} = 650\text{ V}, T_C = 125\text{ °C}$ |      |      | 1<br>100 | $\mu\text{A}$<br>$\mu\text{A}$ |
| $I_{GSS}$     | Gate-body leakage current ( $V_{DS} = 0$ )       | $V_{GS} = \pm 25\text{ V}$  |      |      | 100      | nA                             |
| $V_{GS(th)}$  | Gate threshold voltage                           | $V_{DS} = V_{GS}, I_D = 250\text{ }\mu\text{A}$                         | 3    | 4    | 5        | V                              |
| $R_{DS(on)}$  | Static drain-source on resistance                | $V_{GS} = 10\text{ V}, I_D = 3.5\text{ A}$                              |      | 0.56 | 0.6      | $\Omega$                       |

**Table 5. Dynamic**

| Symbol            | Parameter                             | Test conditions  | Min. | Typ. | Max. | Unit     |
|-------------------|---------------------------------------|--|------|------|------|----------|
| $C_{iss}$         | Input capacitance                     | $V_{DS} = 100\text{ V}, f = 1\text{ MHz},$<br>$V_{GS} = 0$   | -    | 690  | -    | pF       |
| $C_{oss}$         | Output capacitance                    |  |      | 18   |      | pF       |
| $C_{rss}$         | Reverse transfer capacitance          |  |      | 2    |      | pF       |
| $C_{o(tr)}^{(1)}$ | Equivalent capacitance time related   | $V_{DS} = 0\text{ to }520\text{ V}, V_{GS} = 0$  | -    | 17   | -    | pF       |
| $C_{o(er)}^{(2)}$ | Equivalent capacitance energy related |  |      | 52   |      | pF       |
| $R_G$             | Intrinsic gate resistance             | $f = 1\text{ MHz open drain}$  | -    | 2.4  | -    | $\Omega$ |
| $Q_g$             | Total gate charge                     | $V_{DD} = 520\text{ V}, I_D = 3.5\text{ A},$<br>$V_{GS} = 10\text{ V}$<br>(see <a href="#">Figure 15</a> ) | -    | 15   | -    | nC       |
| $Q_{gs}$          | Gate-source charge                    |  |      | 3.6  |      | nC       |
| $Q_{gd}$          | Gate-drain charge                     |  |      | 6    |      | nC       |

- $C_{oss\text{ eq.}}$  time related is defined as a constant equivalent capacitance giving the same charging time as  $C_{oss}$  when  $V_{DS}$  increases from 0 to 80%  $V_{DSS}$
- $C_{oss\text{ eq.}}$  energy related is defined as a constant equivalent capacitance giving the same stored energy as  $C_{oss}$  when  $V_{DS}$  increases from 0 to 80%  $V_{DSS}$

**Table 6. Switching times**

| Symbol       | Parameter           | Test conditions                                | Min. | Typ. | Max | Unit |
|--------------|---------------------|--|------|------|-----|------|
| $t_{d(off)}$ | Turn-off delay time | $V_{DD} = 400\text{ V}$ , $I_D = 4\text{ A}$ , |      | 50   |     | ns   |
| $t_r(V)$     | Rise time           | $R_G = 4.7\ \Omega$ , $V_{GS} = 10\text{ V}$   | -    | 14   | -   | ns   |
| $t_{c(off)}$ | Cross time          | (see <a href="#">Figure 16</a> ),              |      | 20   |     | ns   |
| $t_{f(i)}$   | Fall time           | (see <a href="#">Figure 19</a> )               |      | 11   |     | ns   |

**Table 7. Source drain diode**

| Symbol          | Parameter                     | Test conditions   | Min. | Typ. | Max. | Unit          |
|-----------------|-------------------------------|---|------|------|------|---------------|
| $I_{SD}$        | Source-drain current          |   | -    |      | 7    | A             |
| $I_{SDM}^{(1)}$ | Source-drain current (pulsed) |   | -    |      | 28   | A             |
| $V_{SD}^{(2)}$  | Forward on voltage            | $I_{SD} = 7\text{ A}$ , $V_{GS} = 0$                        | -    |      | 1.5  | V             |
| $t_{rr}$        | Reverse recovery time         | $I_{SD} = 7\text{ A}$ , $di/dt = 100\text{ A}/\mu\text{s}$  | -    | 200  |      | ns            |
| $Q_{rr}$        | Reverse recovery charge       | $V_{DD} = 100\text{ V}$ (see <a href="#">Figure 16</a> )    |      | 1.6  |      | $\mu\text{C}$ |
| $I_{RRM}$       | Reverse recovery current      |   |      | 16   |      | A             |
| $t_{rr}$        | Reverse recovery time         | $I_{SD} = 7\text{ A}$ , $di/dt = 100\text{ A}/\mu\text{s}$  | -    | 263  |      | ns            |
| $Q_{rr}$        | Reverse recovery charge       | $V_{DD} = 100\text{ V}$ , $T_j = 150\text{ }^\circ\text{C}$ | -    | 1.9  |      | $\mu\text{C}$ |
| $I_{RRM}$       | Reverse recovery current      | (see <a href="#">Figure 16</a> )                            |      | 15   |      | A             |

1. Pulse width limited by safe operating area
2. Pulsed: pulse duration = 300  $\mu\text{s}$ , duty cycle 1.5%

## 2.1 Electrical characteristics (curves)

Figure 2. Safe operating area

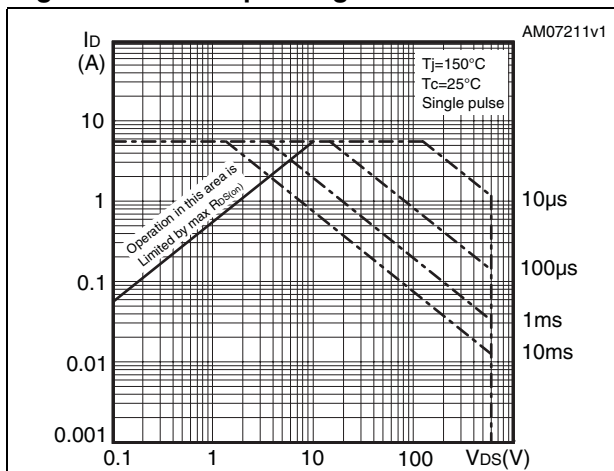

Figure 3. Thermal impedance

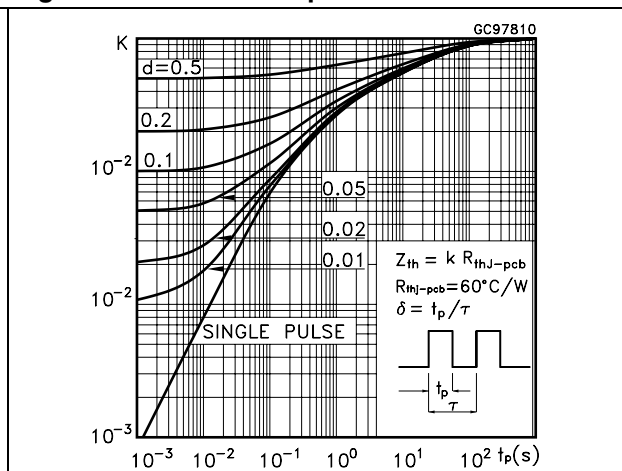

Figure 4. Output characteristics

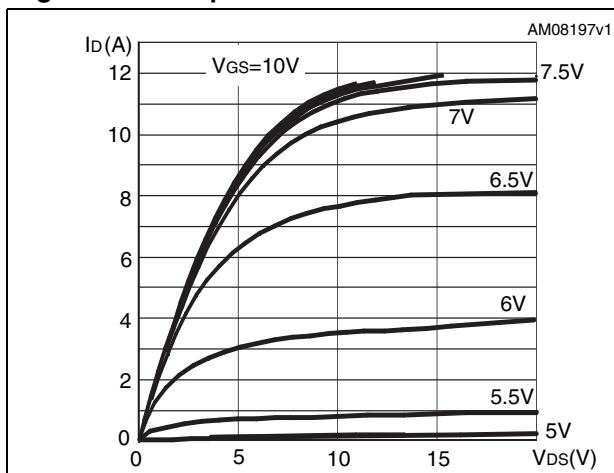

Figure 5. Transfer characteristics

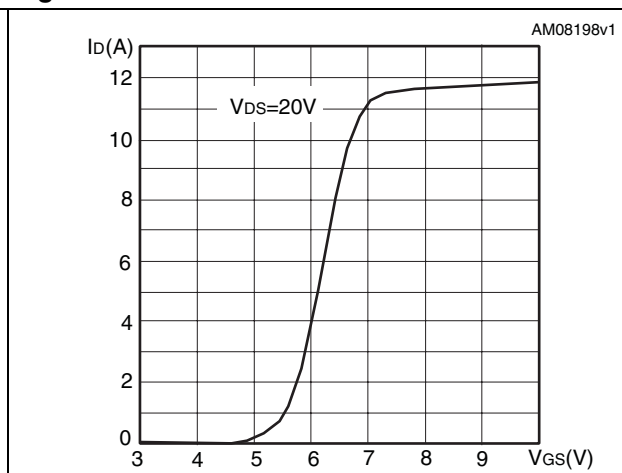

Figure 6. Gate charge vs gate-source voltage

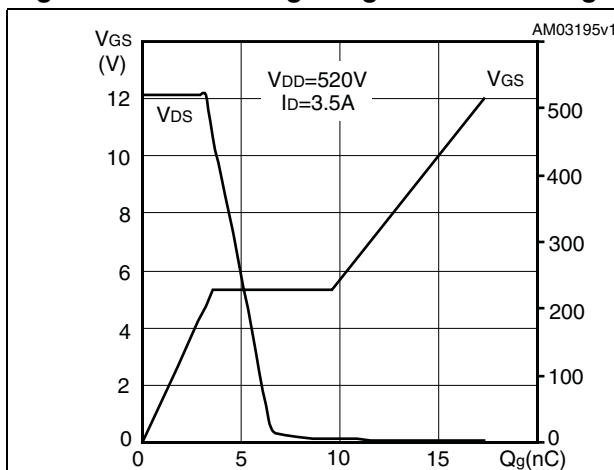

Figure 7. Static drain-source on resistance

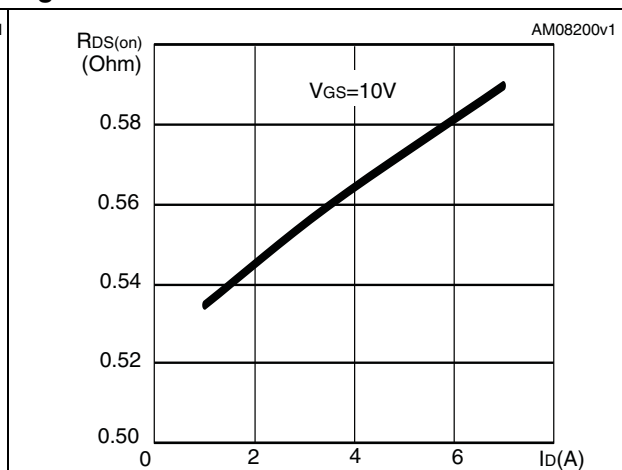

Figure 8. Capacitance variations

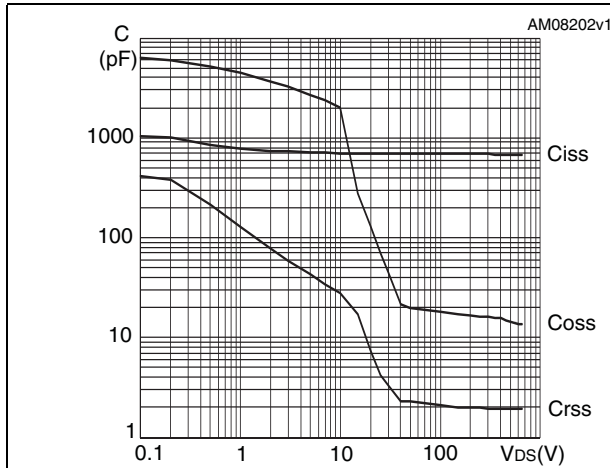

Figure 9. Output capacitance stored energy

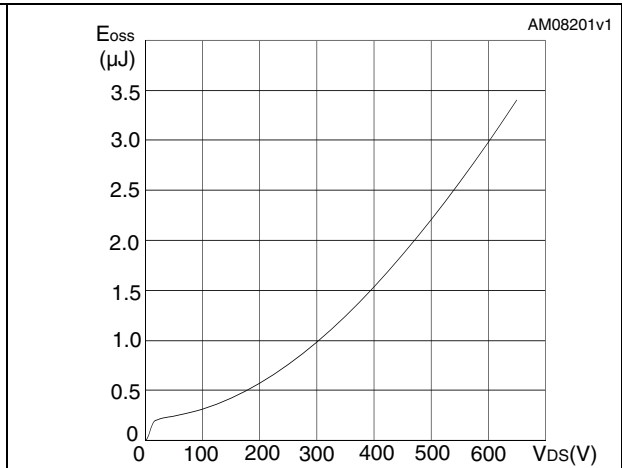

Figure 10. Normalized gate threshold voltage vs temperature

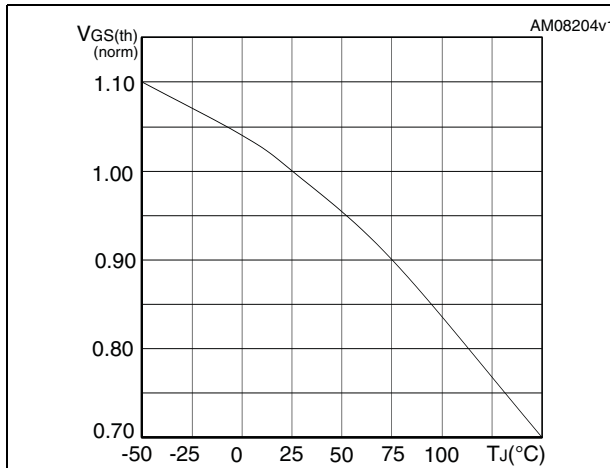

Figure 11. Normalized on resistance vs temperature

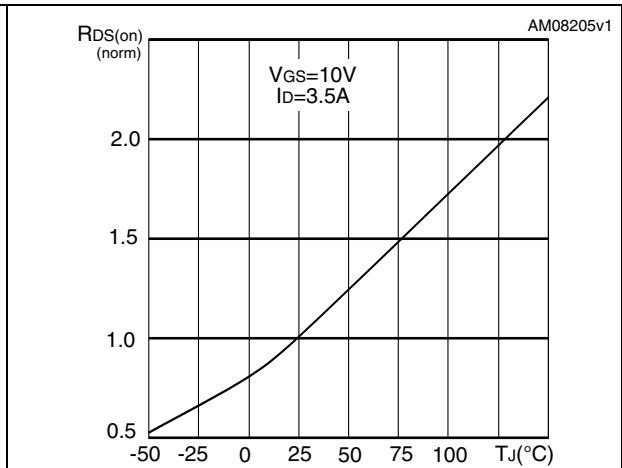

Figure 12. Switching losses vs gate resistance (1)

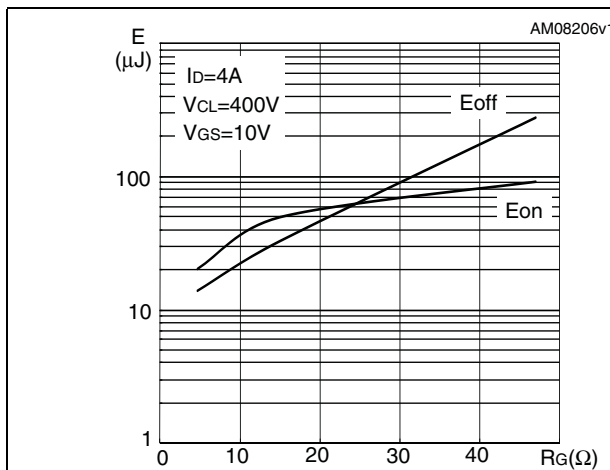
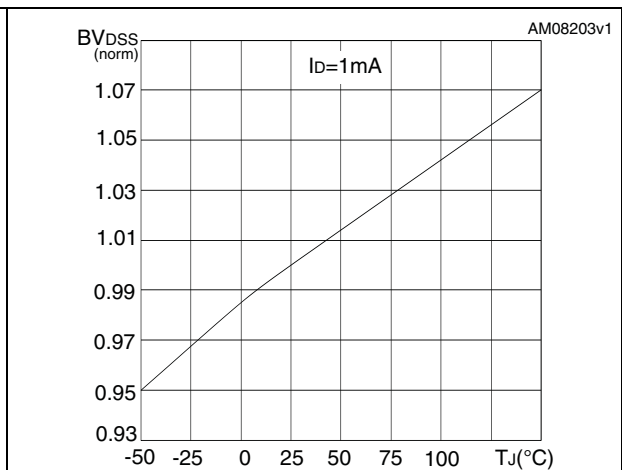

Figure 13. Normalized B<sub>VDSS</sub> vs temperature



1. E<sub>on</sub> including reverse recovery of a SiC diode

### 3 Test circuits

**Figure 14. Switching times test circuit for resistive load**

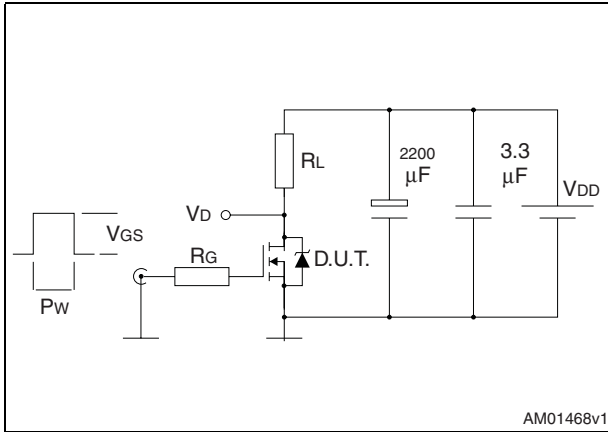

AM01468v1

**Figure 15. Gate charge test circuit**

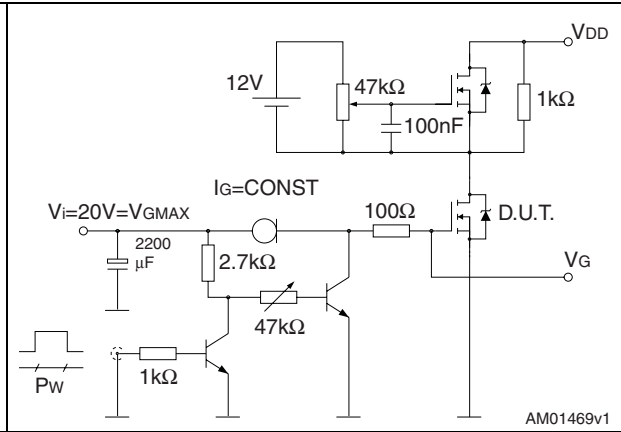

AM01469v1

**Figure 16. Test circuit for inductive load switching and diode recovery times**

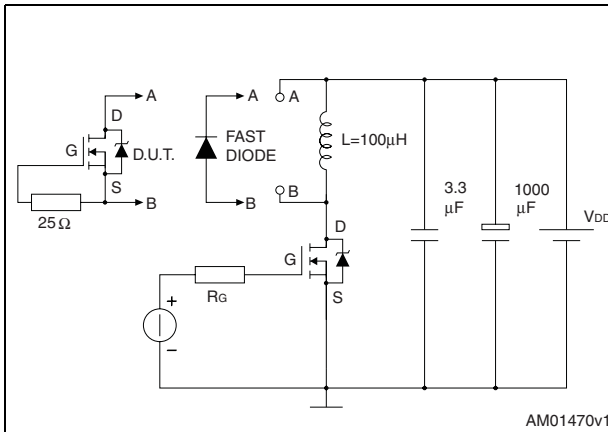

AM01470v1

**Figure 17. Unclamped inductive load test circuit**

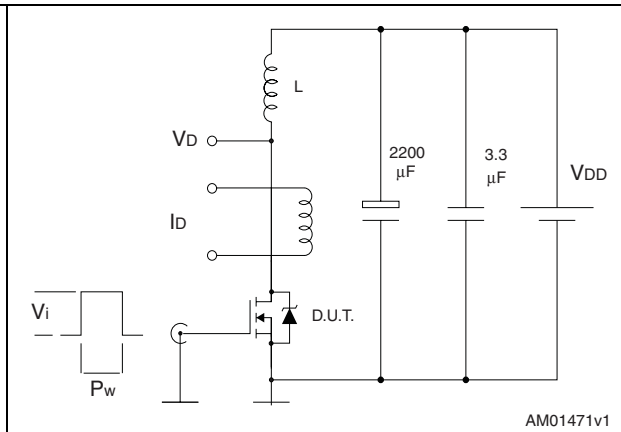

AM01471v1

**Figure 18. Unclamped inductive waveform**

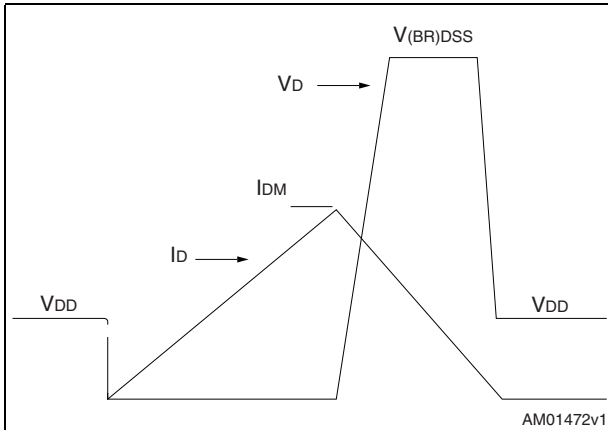

AM01472v1

**Figure 19. Switching time waveform**

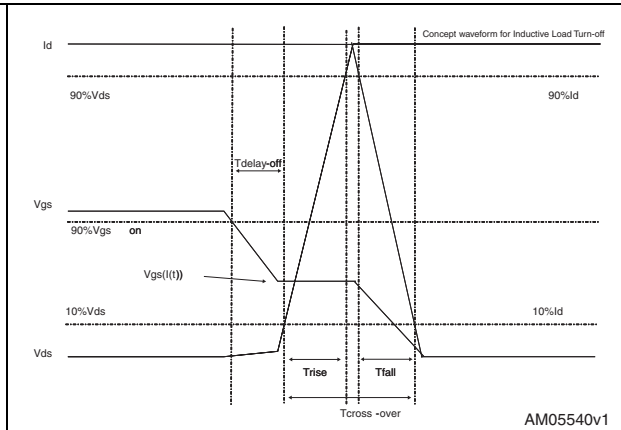

AM05540v1

## 4 Package mechanical data

In order to meet environmental requirements, ST offers these devices in different grades of ECOPACK® packages, depending on their level of environmental compliance. ECOPACK® specifications, grade definitions and product status are available at: [www.st.com](http://www.st.com). ECOPACK is an ST trademark.

Table 8. PowerFLAT™ 5x5 mechanical dimensions

| Dim. | mm   |      |      |
|------|------|------|------|
|      | Min. | Typ. | Max. |
| A    | 0.80 | 0.90 | 1.0  |
| A1   | 0    | 0.02 | 0.05 |
| A3   |      | 0.24 |      |
| D    | 4.90 | 5.0  | 5.10 |
| E    | 4.90 | 5.0  | 5.10 |
| E2   | 2.49 | 2.57 | 2.64 |
| e    | 1.22 | 1.27 | 1.32 |
| b    | 0.43 | 0.51 | 0.58 |
| c    | 0.64 | 0.71 | 0.79 |

Figure 20. PowerFLAT™ 5x5 mechanical drawing

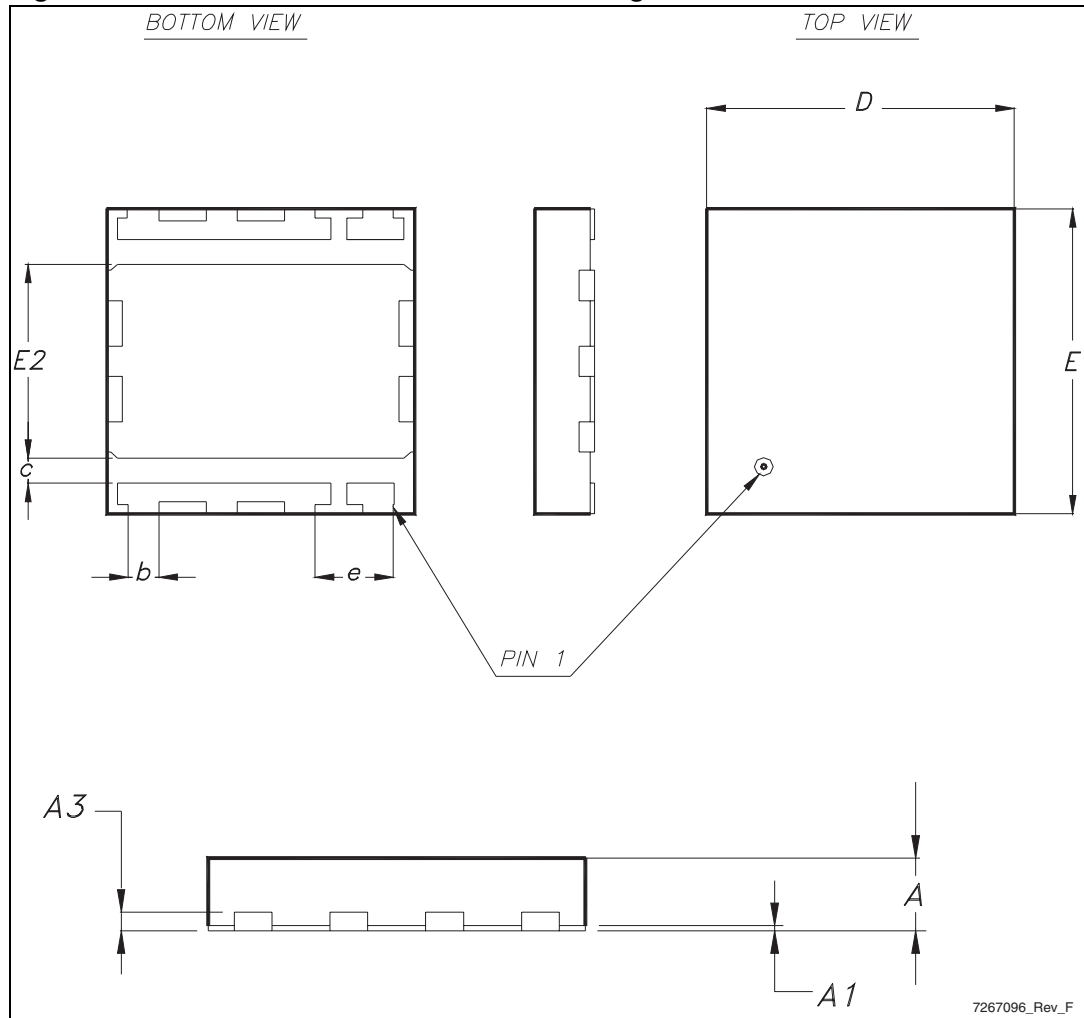
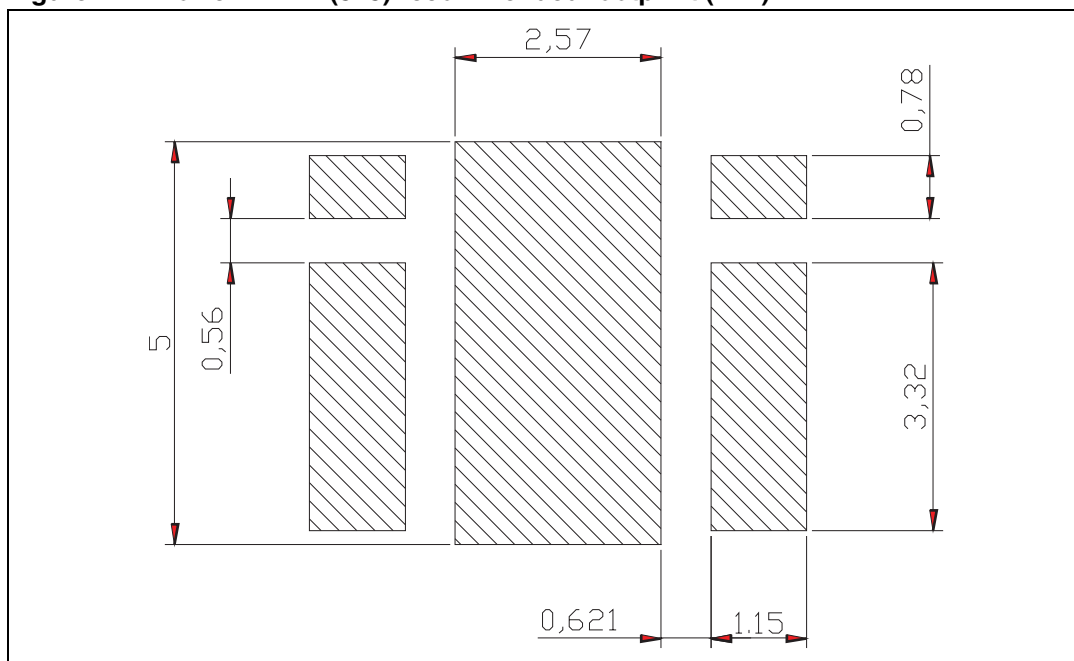

Figure 21. PowerFLAT™(5x5) recommended footprint (mm)



## 5 Revision history

**Table 9. Document revision history**

| Date        | Revision | Changes   |
|-------------|----------|---|
| 05-Jul-2011 | 1        | First release   |
| 07-Jul-2011 | 2        | Updated <a href="#">Figure 1</a> .  |
| 08-Aug-2011 | 3        | Updated <a href="#">Figure 3: Thermal impedance</a> . and $R_{thj-pcb}$ value in <a href="#">Table 3: Thermal data</a> .<br>Minor text changes. |

**Please Read Carefully:**

Information in this document is provided solely in connection with ST products. STMicroelectronics NV and its subsidiaries ("ST") reserve the right to make changes, corrections, modifications or improvements, to this document, and the products and services described herein at any time, without notice.

All ST products are sold pursuant to ST's terms and conditions of sale.

Purchasers are solely responsible for the choice, selection and use of the ST products and services described herein, and ST assumes no liability whatsoever relating to the choice, selection or use of the ST products and services described herein.

No license, express or implied, by estoppel or otherwise, to any intellectual property rights is granted under this document. If any part of this document refers to any third party products or services it shall not be deemed a license grant by ST for the use of such third party products or services, or any intellectual property contained therein or considered as a warranty covering the use in any manner whatsoever of such third party products or services or any intellectual property contained therein.

**UNLESS OTHERWISE SET FORTH IN ST'S TERMS AND CONDITIONS OF SALE ST DISCLAIMS ANY EXPRESS OR IMPLIED WARRANTY WITH RESPECT TO THE USE AND/OR SALE OF ST PRODUCTS INCLUDING WITHOUT LIMITATION IMPLIED WARRANTIES OF MERCHANTABILITY, FITNESS FOR A PARTICULAR PURPOSE (AND THEIR EQUIVALENTS UNDER THE LAWS OF ANY JURISDICTION), OR INFRINGEMENT OF ANY PATENT, COPYRIGHT OR OTHER INTELLECTUAL PROPERTY RIGHT.**

**UNLESS EXPRESSLY APPROVED IN WRITING BY TWO AUTHORIZED ST REPRESENTATIVES, ST PRODUCTS ARE NOT RECOMMENDED, AUTHORIZED OR WARRANTED FOR USE IN MILITARY, AIR CRAFT, SPACE, LIFE SAVING, OR LIFE SUSTAINING APPLICATIONS, NOR IN PRODUCTS OR SYSTEMS WHERE FAILURE OR MALFUNCTION MAY RESULT IN PERSONAL INJURY, DEATH, OR SEVERE PROPERTY OR ENVIRONMENTAL DAMAGE. ST PRODUCTS WHICH ARE NOT SPECIFIED AS "AUTOMOTIVE GRADE" MAY ONLY BE USED IN AUTOMOTIVE APPLICATIONS AT USER'S OWN RISK.**

Resale of ST products with provisions different from the statements and/or technical features set forth in this document shall immediately void any warranty granted by ST for the ST product or service described herein and shall not create or extend in any manner whatsoever, any liability of ST.

ST and the ST logo are trademarks or registered trademarks of ST in various countries.

Information in this document supersedes and replaces all information previously supplied.

The ST logo is a registered trademark of STMicroelectronics. All other names are the property of their respective owners.

© 2011 STMicroelectronics - All rights reserved

STMicroelectronics group of companies

Australia - Belgium - Brazil - Canada - China - Czech Republic - Finland - France - Germany - Hong Kong - India - Israel - Italy - Japan - Malaysia - Malta - Morocco - Philippines - Singapore - Spain - Sweden - Switzerland - United Kingdom - United States of America

[www.st.com](http://www.st.com)

## Looking for pricing, stock, or lifecycle information?

Click below to explore more details on WIN SOURCE:

- ⊖ [View STL8N65M5 on WIN SOURCE](#)
- ⊖ [STMicroelectronics Information](#)

## Optimize Your Supply Chain with WIN SOURCE Solutions

- ✓ Global Sourcing Solution
- ✓ Obsolete Management
- ✓ Cost Control Management
- ✓ Shortage Management
- ✓ Alternative Solution
- ✓ Excess Inventory Management