



**THE DATASHEET OF
AD8216YRZ**



FEATURES

- ±4000 V HBM ESD**
- Ideal for current shunt applications**
- High common-mode voltage range**
 - 4 V to +65 V operating
 - 40 V to +80 V survival
- 3 MHz bandwidth**
- <100 ns output propagation delay**
- Gain: 3 V/V**
- Wide operating temperature range**
 - Die: –40°C to +150°C
 - 8-lead SOIC: –40°C to +125°C
- Adjustable output offset**
- Available in 8-lead SOIC**
- Excellent ac and dc performance**
 - 10 $\mu\text{V}/^\circ\text{C}$ offset drift
 - 10 ppm/ $^\circ\text{C}$ gain drift
- Qualified for automotive applications**

APPLICATIONS

- High-side current sensing in**
 - DC-to-dc converters
 - Motor controls
 - Transmission controls
 - Diesel-injection controls
 - Engine management
 - Suspension controls
 - Vehicle dynamic controls

GENERAL DESCRIPTION

The **AD8216** is a single-supply, difference amplifier ideal for amplifying small differential voltages in the presence of large common-mode voltages. The operating input common-mode voltage range extends from –4 V to +65 V. The typical supply voltage is 5 V. The **AD8216** features a 3 MHz bandwidth, allowing for the input-to-output propagation delay that is always less than 150 ns. This feature is ideal for applications monitoring rapidly increasing and decreasing load currents.

The **AD8216** is offered in a SOIC package. The operating temperature range is –40°C to +125°C.

FUNCTIONAL BLOCK DIAGRAM

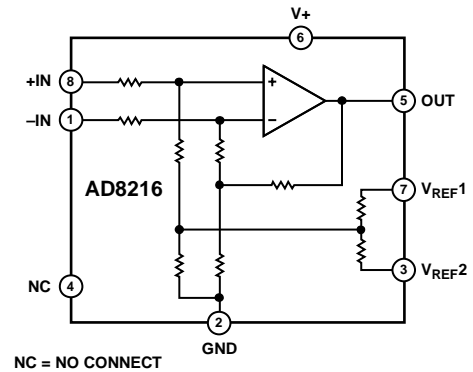

Figure 1.

07062-2001

Excellent ac and dc performance over temperature keep errors in the measurement loop to a minimum. Offset and gain drift are guaranteed to a maximum of 20 $\mu\text{V}/^\circ\text{C}$ and 15 ppm/ $^\circ\text{C}$, respectively.

The output offset can be adjusted from 0.06 V to 4.9 V with a 5 V supply by using the V_{REF1} pin and the V_{REF2} pin. With the V_{REF1} pin attached to the V_+ pin and the V_{REF2} pin attached to the GND pin, the output is set at half scale. Attaching both V_{REF1} and V_{REF2} to GND causes the output to be unipolar, starting near ground. Attaching both V_{REF1} and V_{REF2} to V_+ causes the output to be unipolar, starting near V_+ . Other offsets can be obtained by applying an external voltage to V_{REF1} and V_{REF2} .

Rev. C

[Document Feedback](#)

Information furnished by Analog Devices is believed to be accurate and reliable. However, no responsibility is assumed by Analog Devices for its use, nor for any infringements of patents or other rights of third parties that may result from its use. Specifications subject to change without notice. No license is granted by implication or otherwise under any patent or patent rights of Analog Devices. Trademarks and registered trademarks are the property of their respective owners.

TABLE OF CONTENTS

Features	1	Ground Referenced Output	11
Applications.....	1	V+ Referenced Output	11
Functional Block Diagram	1	Bidirectional Operation.....	11
General Description	1	External ReferenceD Output	12
Revision History	2	Splitting the Supply	12
Specifications.....	3	Splitting an External Reference	12
Absolute Maximum Ratings.....	4	Applications Information	13
ESD Caution.....	4	High-Side Current Sense with a Low-Side Switch.....	13
Pin Configuration and Function Descriptions.....	5	High-Side Current Sense with a High-Side Switch	13
Typical Performance Characteristics	6	Outline Dimensions	14
Theory of Operation	10	Ordering Guide	14
Output Offset Adjustment.....	11	Automotive Products.....	14
Unidirectional Operation.....	11		

REVISION HISTORY

9/15—Rev. B to Rev. C

Changes to Figure 23.....	10
---------------------------	----

10/11—Rev. A to Rev. B

Changes to Ordering Guide	14
Added Automotive Products Section	14

9/08—Rev. 0 to Rev. A

Changes to Features Section.....	1
Changes to Figure 7.....	6
Changes to Figure 21.....	8
Changes to Table 4 and Figure 25.....	11

11/07—Revision 0: Initial Version

SPECIFICATIONS

T_A = operating temperature range, $V_S = 5\text{ V}$, unless otherwise noted.

Table 1.

Parameter	Test Conditions/Comments	Min	Typ	Max	Unit
GAIN					
Initial			3		V/V
Accuracy	$V_{OUT} \geq 0.1\text{ V dc}$, 25°C			± 0.25	%
Accuracy Over Temperature	Specified temperature range			± 0.4	%
Gain vs. Temperature			10	15	ppm/ $^\circ\text{C}$
VOLTAGE OFFSET					
Offset Voltage, RTI	25°C		± 0.5		mV
Over Temperature, RTI	Specified temperature range			± 3	mV
Offset Drift			± 10	± 20	$\mu\text{V}/^\circ\text{C}$
INPUT					
Input Impedance					
Differential			400		k Ω
Common Mode			200		k Ω
Input Voltage Range	Common mode, continuous	-4		+65	V
	Differential, V_{REF1} and V_{REF2} tied to GND		1.6		V
	Differential, V_{REF1} @ GND and V_{REF2} @ 5 V	-800		+800	mV
Common-Mode Rejection	25°C , $f = \text{dc to } 20\text{ kHz}^1$	80	90		dB
	Operating temperature range, $f = \text{dc to } 20\text{ kHz}^1$	80	90		dB
OUTPUT					
Output Voltage Range	$R_L = 25\text{ k}\Omega$	0.06		4.9	V
Output Resistance			200		Ω
DYNAMIC RESPONSE					
Small Signal -3 dB Bandwidth			3		MHz
Slew Rate			15		V/ μs
Propagation Delay	Input-to-output response		100	150	ns
NOISE					
0.1 Hz to 10 Hz, RTI			20		$\mu\text{V p-p}$
Spectral Density, 1 kHz, RTI			0.5		$\mu\text{V}/\sqrt{\text{Hz}}$
OFFSET ADJUSTMENT					
Ratiometric Accuracy ²	Divider to supplies	0.499		0.501	V/V
Accuracy, RTO	Voltage applied to V_{REF1} and V_{REF2} in parallel			± 0.5	mV/V
Output Offset Adjustment Range	$V_S = 5\text{ V}$	0.06		4.9	V
VREF Input Voltage Range		0.0		V_S	V
VREF Divider Resistor Values		24	32	40	k Ω
POWER SUPPLY					
Operating Range		4.5		5.5	V
Quiescent Current Over Temperature	$V_{OUT} = 0.1\text{ V dc}$		1	2	mA
Power Supply Rejection Ratio		70			dB
TEMPERATURE RANGE					
For Specified Performance	Operating temperature range	-40		+125	$^\circ\text{C}$

¹ Source imbalance < 2 Ω .

² The offset adjustment is ratiometric to the power supply when V_{REF1} and V_{REF2} are used as a divider between the supplies.

ABSOLUTE MAXIMUM RATINGS

Table 2.

Parameter	Rating
Supply Voltage	12.5 V
Continuous Input Common-Mode Voltage	-40 V to +80 V
Continuous Input Differential Voltage	6 V
Reverse Supply Voltage	0.3 V
ESD Rating	
HBM (Human Body Model)	±4000 V
CDM (Charged Device Model)	±1000 V
Operating Temperature Range	-40°C to +125°C
Storage Temperature Range	-65°C to +150°C
Output Short-Circuit Duration	Indefinite

Stresses at or above those listed under Absolute Maximum Ratings may cause permanent damage to the product. This is a stress rating only; functional operation of the product at these or any other conditions above those indicated in the operational section of this specification is not implied. Operation beyond the maximum operating conditions for extended periods may affect product reliability.

ESD CAUTION



ESD (electrostatic discharge) sensitive device. Charged devices and circuit boards can discharge without detection. Although this product features patented or proprietary protection circuitry, damage may occur on devices subjected to high energy ESD. Therefore, proper ESD precautions should be taken to avoid performance degradation or loss of functionality.

PIN CONFIGURATION AND FUNCTION DESCRIPTIONS

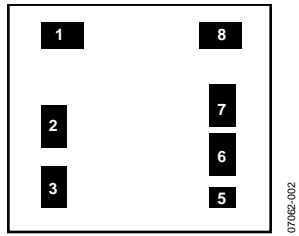

Figure 2. Metallization Diagram

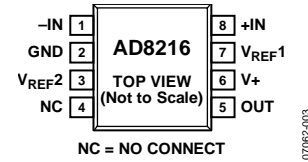

Figure 3. Pin Configuration

Table 3. Pin Function Descriptions

Pin No.	Mnemonic	X	Y
1	-IN	-320	+390
2	GND	-357	+14
3	V _{REF2}	-349	-201
4	NC	NC	NC
5	OUT	+348	-325
6	V+	+349	-194
7	V _{REF1}	+349	-26
8	+IN	+318	+390

Die size is 1100 μm by 1035 μm .

Die thickness is 13 mil.

Minimum passivation opening (minimum bond pad size) is 92 μm \times 92 μm .

Passivation type is 8 kA USG (Oxide) + 10 kA Oxynitride.

Bond pad metal composition is 98.5% Al, 1% Si, and 0.5% Cu.

Backside potential is V+.

TYPICAL PERFORMANCE CHARACTERISTICS

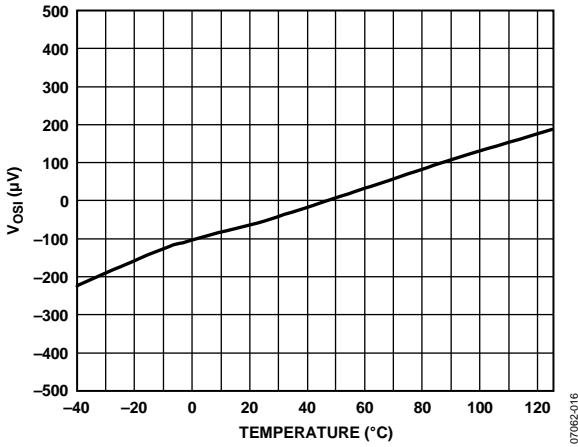

Figure 4. Typical Offset Drift

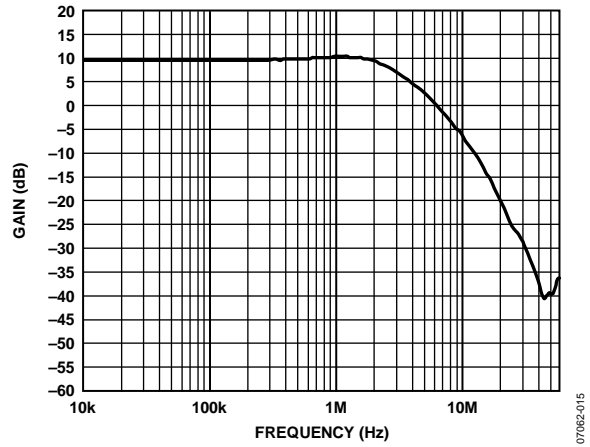

Figure 7. Typical Small Signal Bandwidth ($V_{OUT} = 200\text{ mV p-p}$)

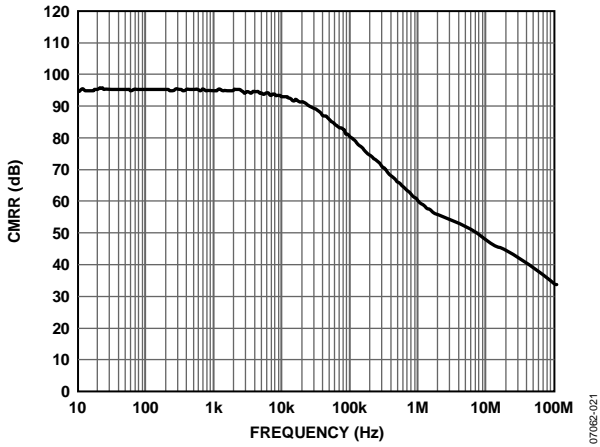

Figure 5. CMRR vs. Frequency

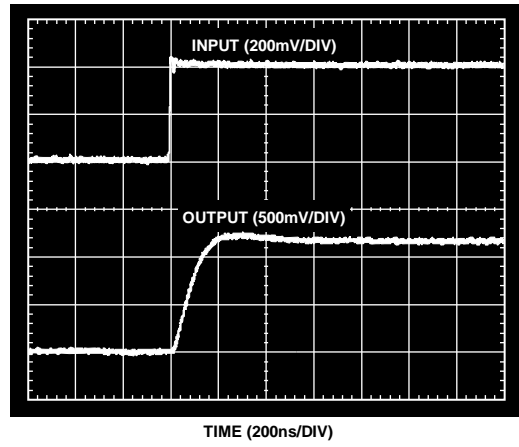

Figure 8. Rise Time

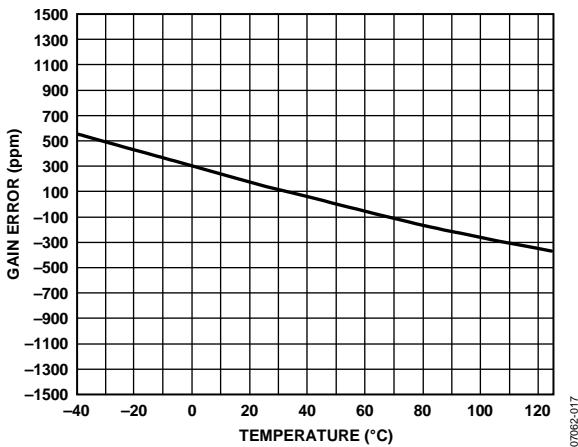

Figure 6. Typical Gain Drift

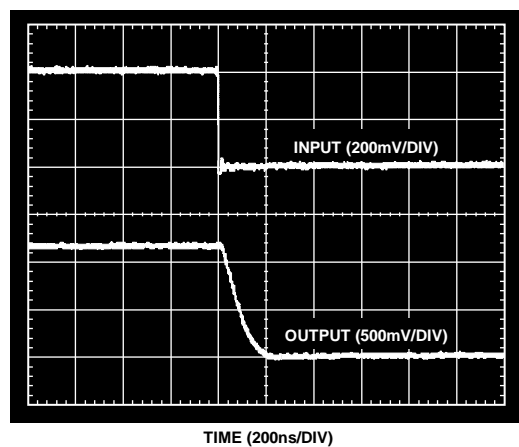

Figure 9. Fall Time

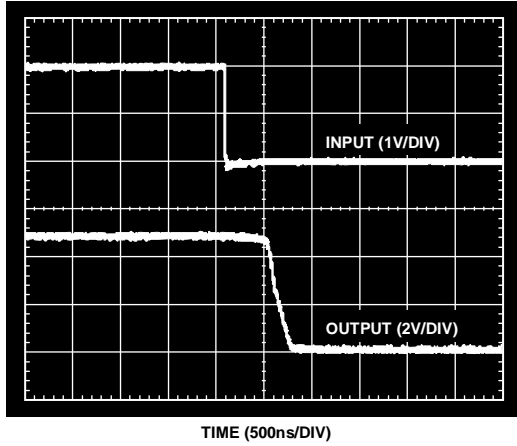

Figure 10. Differential Overload Recovery (Falling)

07062-008

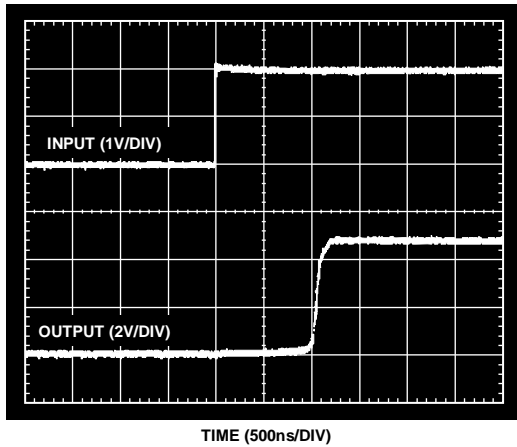

Figure 11. Differential Overload Recovery (Rising)

07062-009

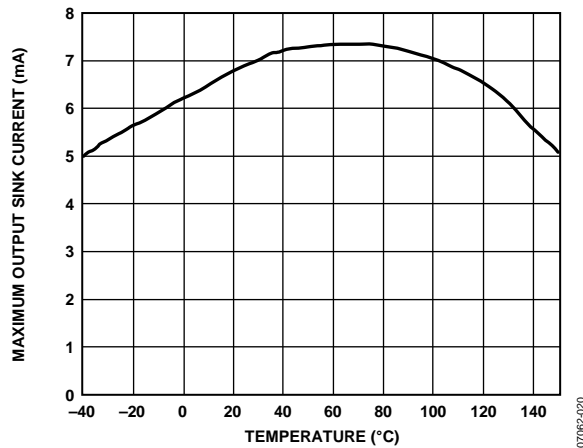

Figure 12. Maximum Output Sink Current vs. Temperature

07062-020

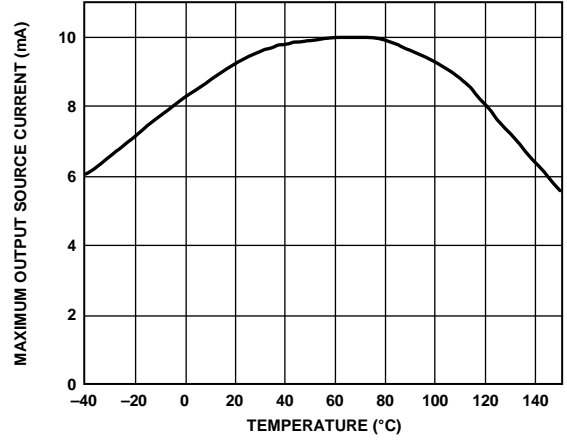

Figure 13. Maximum Output Source Current vs. Temperature

07062-019

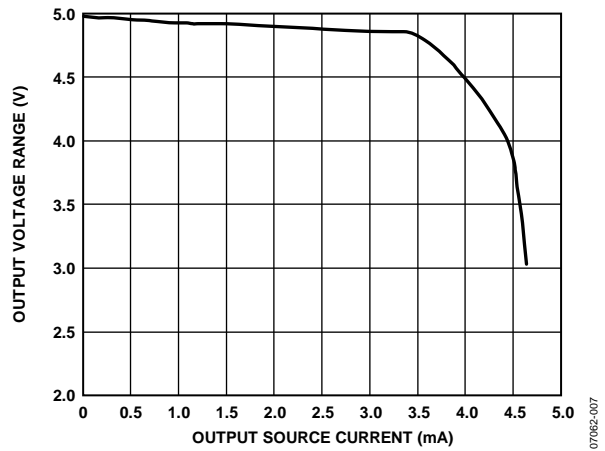

Figure 14. Output Voltage Range vs. Output Source Current

07062-007

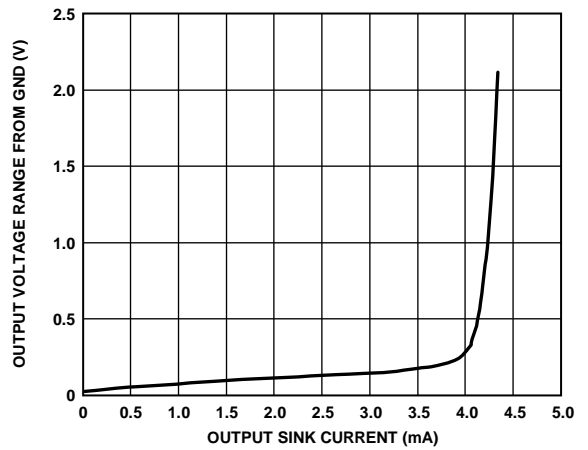

Figure 15. Output Voltage Range from GND vs. Output Sink Current

07062-006

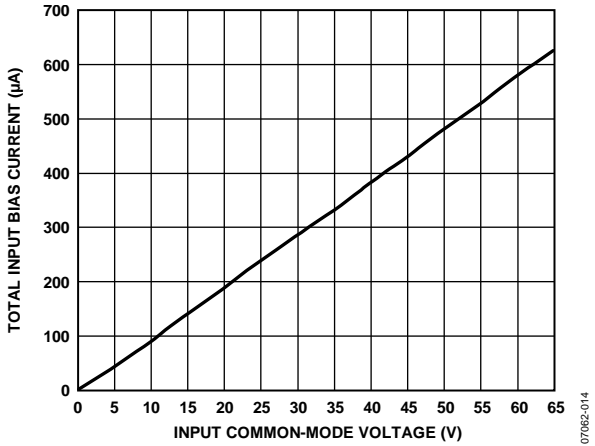

Figure 16. Total Input Bias Current vs. Input Common-Mode Voltage

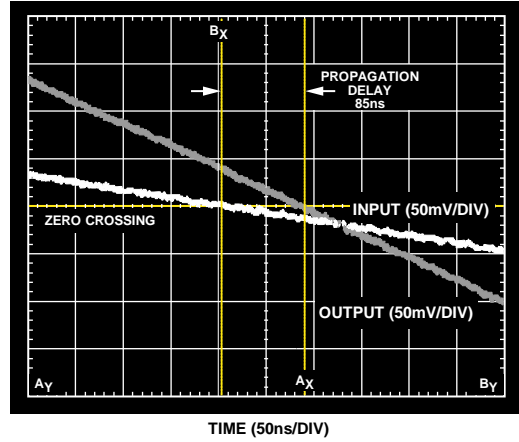

Figure 19. Propagation Delay (Falling)

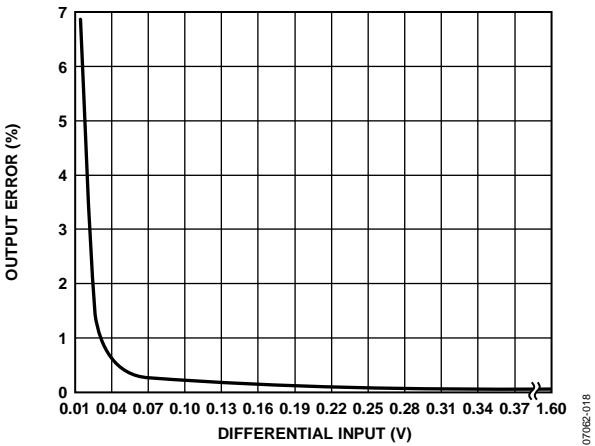

Figure 17. Output Error (%) vs. Differential Input Voltage (Unidirectional Operation (V_{REF1} and V_{REF2} Connected to GND))

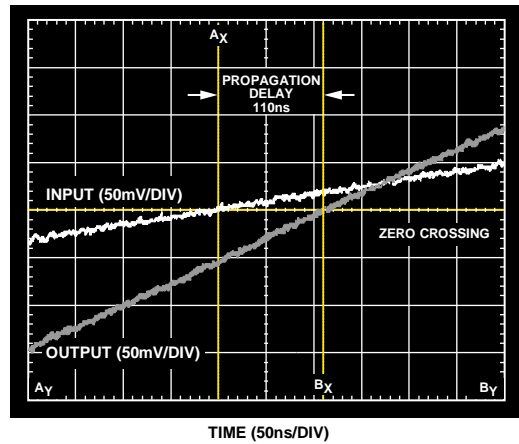

Figure 20. Propagation Delay (Rising)

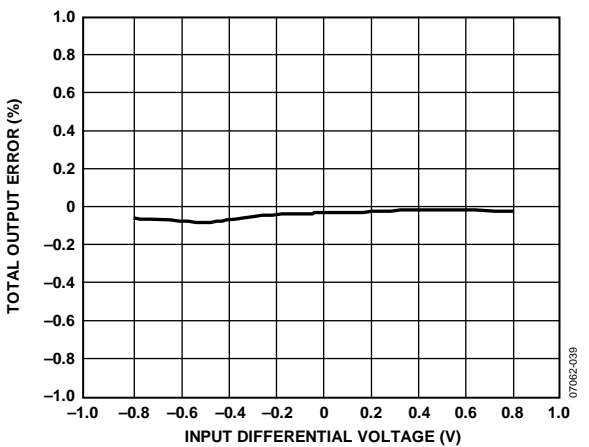

Figure 18. Output Error (%) vs. Differential Input Voltage (Bidirectional Operation (V_{REF1} and V_{REF2} Connected to 2.5 V))

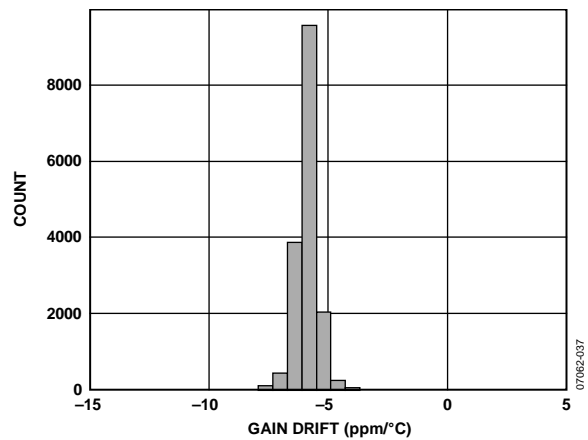

Figure 21. Gain Drift Distribution

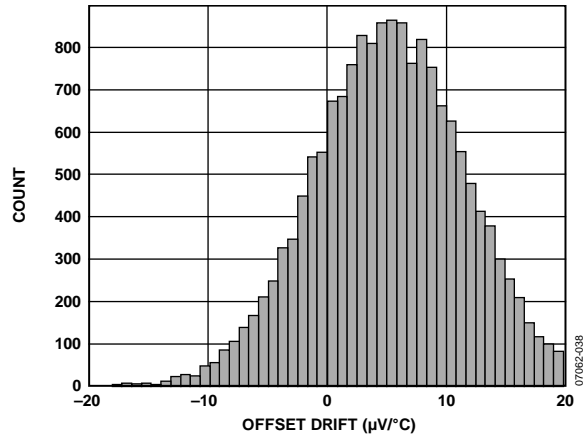

Figure 22. Offset Drift Distribution

THEORY OF OPERATION

The AD8216 is a single-supply difference amplifier typically used to accurately amplify a small differential current shunt voltage in the presence of a rapidly changing common-mode voltage.

The AD8216 consists of an amplifier (A1), a resistor network, a small voltage reference, and a bias circuit (not shown), see Figure 23.

The set of input attenuators preceding A1 consist of R_A , R_B , and R_C , which feature a combined series resistance of approximately $200\text{ k}\Omega \pm 20\%$. The purpose of these resistors is to attenuate the input voltage to match the input voltage range of A1. This balanced resistor network attenuates the common-mode signal by a ratio of $1/18$. A1 amplifier inputs are held within the power supply range, even if Pin 1 and Pin 8 exceed the supply or fall below common (ground). A reference voltage of 250 mV biases the attenuator above ground, which allows the amplifier to operate in the presence of negative common-mode voltages.

The input resistor network also attenuates normal (differential) mode voltages. Therefore, Amplifier A1 features a gain of 54 V/V to provide a total system gain of 3 V/V .

$$\text{Total Gain (V/V)} = 1/18 (\text{V/V}) \times 54 (\text{V/V}) = 3 \text{ V/V}$$

The reference inputs, V_{REF1} and V_{REF2} , are tied through resistors to the positive input of A1, which allows the output offset to be adjusted anywhere in the output operating range. The gain is 1 V/V from the reference pins to the output when the reference pins are used in parallel. When they are used to divide the supply, the gain is 0.5 V/V .

The ratios of R_A , R_B , R_C , and R_F are trimmed to a high level of precision to allow the CMRR to exceed 80 dB . This performance is accomplished by laser trimming the resistor ratio matching to better than 0.01% .

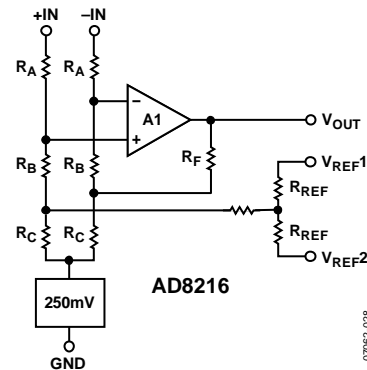

Figure 23. Simplified Schematic

OUTPUT OFFSET ADJUSTMENT

The output of the AD8216 can be adjusted for unidirectional or bidirectional operation.

UNIDIRECTIONAL OPERATION

Unidirectional operation allows the AD8216 to measure currents through a resistive shunt in one direction. The basic modes for unidirectional operation are ground referenced output mode and V+ referenced output mode.

For unidirectional operation, the output can be set at the negative rail (near ground) or at the positive rail (near V+) when the differential input is 0 V. The output moves to the opposite rail when a correct polarity differential input voltage is applied. In this case, full scale is approximately 1.6 V. The required polarity of the differential input depends on the output voltage setting. If the output is set at the positive rail, the input polarity needs to be negative to move the output down. If the output is set at ground, the polarity is positive to move the output up.

GROUND REFERENCED OUTPUT

When using the AD8216 in this mode, both referenced inputs are tied to ground, which causes the output to sit at the negative rail when there are zero differential volts at the input (see Figure 24).

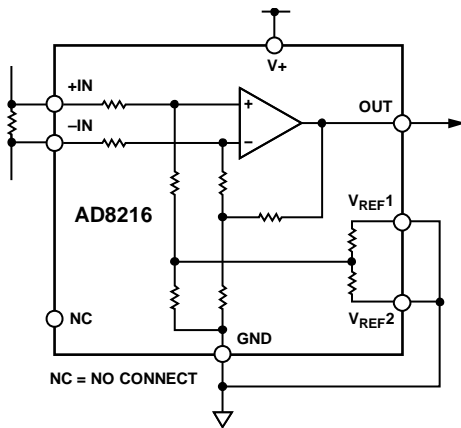

Figure 24. Ground Referenced Output

Table 4. V+ = 5 V

V _{IN} (Referred to -IN)	V _{OUT}
0 V	0.1 V
1.6 V	4.8 V

V+ REFERENCED OUTPUT

The V+ referenced output mode is set when both reference pins are tied to the positive supply. It is typically used when the diagnostic scheme requires detection of the amplifier and the wiring before power is applied to the load (see Figure 25).

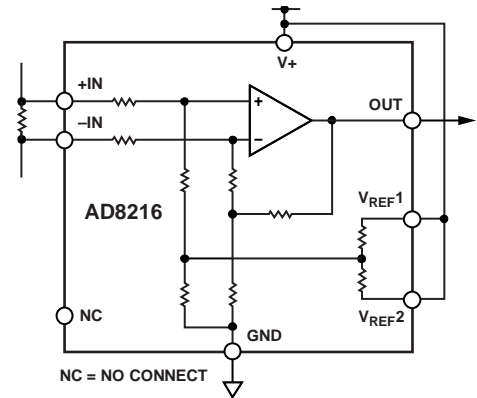

Figure 25. V+ Referenced Output

Table 5. V+ = 5 V

V _{IN} (Referred to -IN)	V _{OUT}
0 V	4.9 V
-1.6 V	0.1 V

BIDIRECTIONAL OPERATION

Bidirectional operation allows the AD8216 to measure currents through a resistive shunt in two directions.

In this case, the output is set anywhere within the output range. Typically, it is set at half scale for equal range in both directions. In some cases, however, it is set at a voltage other than half scale when the bidirectional current is nonsymmetrical.

Table 6. V+ = 5 V, V_{OUT} = 2.5 V with V_{IN} = 0 V

V _{IN} (Referred to -IN)	V _{OUT}
+800 mV	4.9 V
-800 mV	0.1 V

Adjusting the output is accomplished by applying voltage(s) to the referenced inputs.

V_{REF1} and V_{REF2} are tied to internal resistors that connect to an internal offset node. There is no operational difference between the pins.

EXTERNAL REFERENCED OUTPUT

Tying both pins together and to a reference produces an output equal to the reference voltage when there is no differential input (see Figure 26). The output moves down from the reference voltage when the input is negative, relative to the -IN pin, and up when the input is positive, relative to the -IN pin.

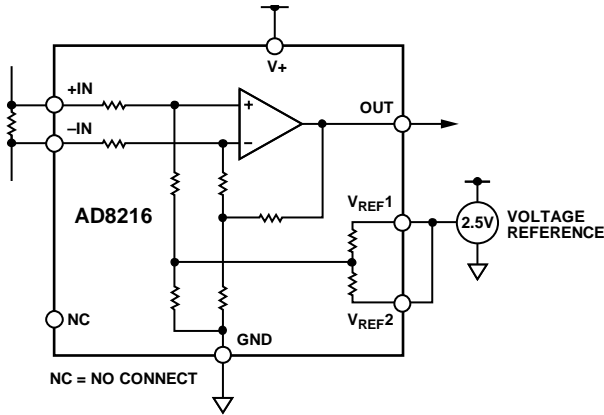

Figure 26. External Referenced Output

SPLITTING THE SUPPLY

By tying one reference pin to V+ and the other to the ground pin, the output is set at half of the supply when there is no differential input (see Figure 27). The benefit is that no external reference is required to offset the output for bidirectional current measurement. This configuration creates a midscale offset that is ratiometric to the supply, which means that if the supply increases or decreases, the output remains at half the supply. For example, if the supply is 5.0 V, the output is at half scale or 2.5 V. If the supply increases by 10% (to 5.5 V), the output goes to 2.75 V.

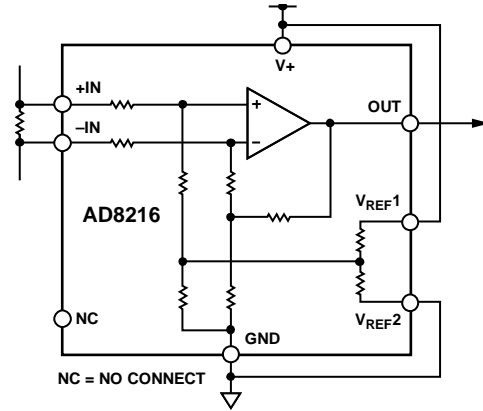

Figure 27. Split Supply

SPLITTING AN EXTERNAL REFERENCE

In this case, an external reference is divided by 2 with an accuracy of approximately 0.5% by connecting one VREF pin to ground and the other VREF pin to the reference (see Figure 28).

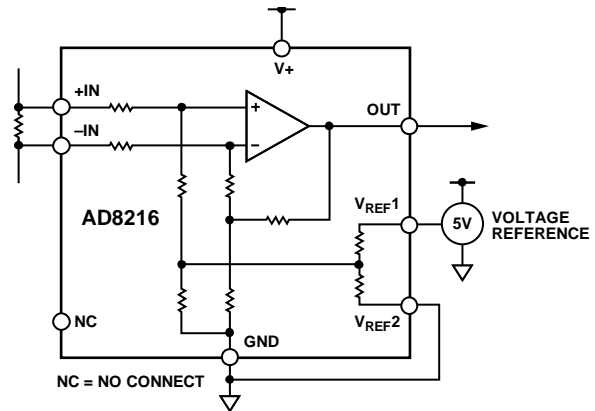

Figure 28. Split External Reference

07062-031

07062-032

07062-033

APPLICATIONS INFORMATION

A typical application for the AD8216 is high-side measurement of a current through a solenoid for PWM control of the solenoid opening. Typical applications include dc-to-dc converters, motor controls, and solenoid controls.

Two typical circuit configurations are used for this type of application.

HIGH-SIDE CURRENT SENSE WITH A LOW-SIDE SWITCH

In this case, the PWM control switch is ground referenced. An inductive load (solenoid) is tied to a power supply. A resistive shunt is placed between the switch and the load (see Figure 29). An advantage of placing the shunt on the high side is that the entire current, including the recirculation current, can be measured because the shunt remains in the loop when the switch is off. In addition, diagnostics can be enhanced because shorts to ground can be detected with the shunt on the high side.

In this circuit configuration, when the switch is closed, the common-mode voltage moves down to near the negative rail. When the switch is opened, the voltage reversal across the inductive load causes the common-mode voltage to be held one diode drop above the battery by the clamp diode.

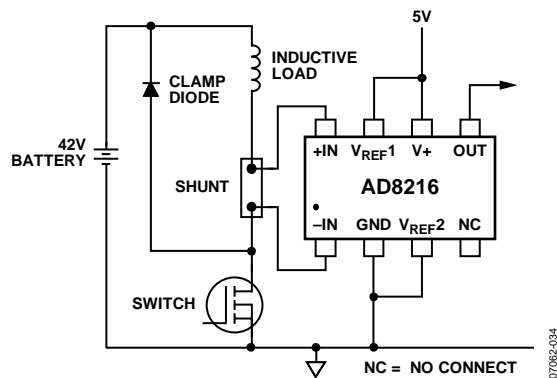

Figure 29. Low-Side Switch

HIGH-SIDE CURRENT SENSE WITH A HIGH-SIDE SWITCH

This configuration minimizes the possibility of unexpected solenoid activation and excessive corrosion (see Figure 30). In this case, both the switch and the shunt are on the high side. When the switch is off, it removes the battery from the load, which prevents damage from potential shorts to ground, while still allowing the recirculating current to be measured and providing for diagnostics. Removing the power supply from the load for the majority of the time minimizes the corrosive effects that could be caused by the differential voltage between the load and ground.

When using a high-side switch, the battery voltage is connected to the load when the switch is closed, causing the common-mode voltage to increase to the battery voltage. In this case, when the switch is opened, the voltage reversal across the inductive load causes the common-mode voltage to be held one diode drop below ground by the clamp diode.

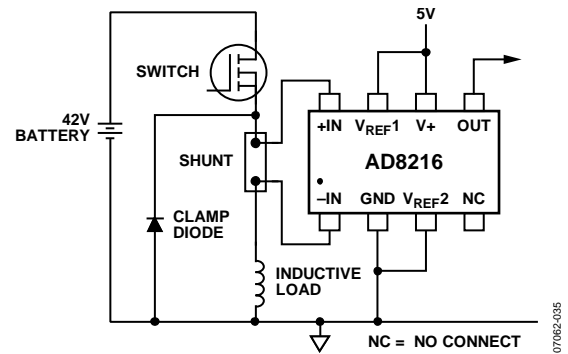

Figure 30. High-Side Switch

Another typical application for the AD8216 is as part of the control loop in H-bridge motor controls. In this case, the AD8216 is placed in the middle of the H-bridge so that it can accurately measure current in both directions by using the shunt available at the motor (see Figure 31). This is a better solution than a ground referenced op amp because ground is not typically a stable reference voltage in this type of application. This instability in the ground reference causes the measurements that could be made with a simple ground referenced op amp to be inaccurate.

The AD8216 measures current in both directions as the H-bridge switches and the motor changes direction. The output of the AD8216 is configured in an external reference bidirectional mode (see the Output Offset Adjustment section).

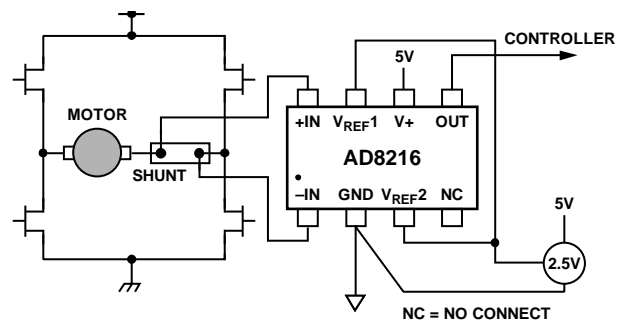
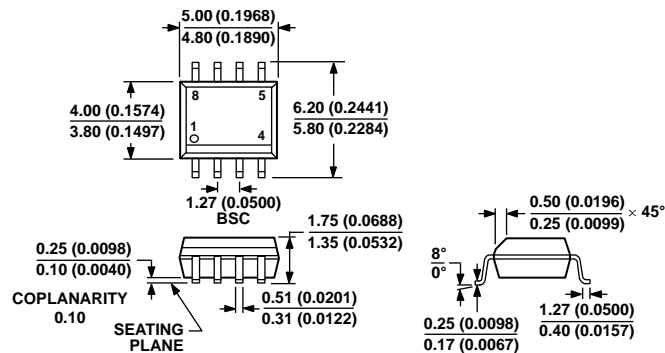

Figure 31. Motor Control Application

OUTLINE DIMENSIONS



COMPLIANT TO JEDEC STANDARDS MS-012-AA
 CONTROLLING DIMENSIONS ARE IN MILLIMETERS; INCH DIMENSIONS
 (IN PARENTHESES) ARE ROUNDED-OFF MILLIMETER EQUIVALENTS FOR
 REFERENCE ONLY AND ARE NOT APPROPRIATE FOR USE IN DESIGN.

012807-A

Figure 32. 8-Lead Standard Small Outline Package [SOIC_N]
 Narrow Body (R-8)
 Dimensions shown in millimeters and (inches)

ORDERING GUIDE

Model ^{1,2}	Temperature Range	Package Description	Package Option
AD8216YRZ	-40°C to +125°C	8-Lead SOIC_N	R-8
AD8216YRZ-RL	-40°C to +125°C	8-Lead SOIC_N, 13" Tape and Reel	R-8
AD8216YRZ-R7	-40°C to +125°C	8-Lead SOIC_N, 7" Tape and Reel	R-8
AD8216WYRZ	-40°C to +125°C	8-Lead SOIC_N	R-8
AD8216WYRZ-RL	-40°C to +125°C	8-Lead SOIC_N, 13" Tape and Reel	R-8
AD8216WYRZ-R7	-40°C to +125°C	8-Lead SOIC_N, 7" Tape and Reel	R-8

¹ Z = RoHS Compliant Part.

² W = Qualified for Automotive Applications.

AUTOMOTIVE PRODUCTS

The [AD8216W](#) models are available with controlled manufacturing to support the quality and reliability requirements of automotive applications. Note that these automotive models may have specifications that differ from the commercial models; therefore, designers should review the Specifications section of this data sheet carefully. Only the automotive grade products shown are available for use in automotive applications. Contact your local Analog Devices account representative for specific product ordering information and to obtain the specific Automotive Reliability reports for these models.

NOTES

NOTES

Looking for pricing, stock, or lifecycle information?

Click below to explore more details on WIN SOURCE:

 [View AD8216YRZ on WIN SOURCE](#)

 [Analog Devices Inc. Information](#)

Optimize Your Supply Chain with WIN SOURCE Solutions

-  Global Sourcing Solution
-  Obsolete Management
-  Cost Control Management
-  Shortage Management
-  Alternative Solution
-  Excess Inventory Management