



**THE DATASHEET OF
NE68830-T1-A**



FEATURES

- **LOW PHASE NOISE DISTORTION**
- **LOW NOISE:** 1.5 dB at 2.0 GHz
- **LOW VOLTAGE OPERATION**
- **LARGE ABSOLUTE MAXIMUM COLLECTOR CURRENT:** I_C MAX = 100 mA
- **AVAILABLE IN SIX LOW COST PLASTIC SURFACE MOUNT PACKAGE STYLES**
- **ALSO AVAILABLE IN CHIP FORM**

DESCRIPTION

NEC's NE688 series of NPN epitaxial silicon transistors are designed for low cost amplifier and oscillator applications. Low noise figures, high gain and high current capability equate to wide dynamic range and excellent linearity. NE688's low phase noise distortion and high f_T make it an excellent choice for oscillator applications up to 5 GHz. The NE688 series is available in six different low cost plastic surface mount package styles, and in chip form.



ELECTRICAL CHARACTERISTICS (TA = 25°C)

SYMBOLS	PARAMETERS AND CONDITIONS	UNITS	PART NUMBER ¹ EIAJ ² REGISTERED NUMBER PACKAGE OUTLINE			NE68818 2SC5194 18			NE68819 2SC5195 19			NE68830 2SC5193 30			NE68833 2SC5191 33			NE68839/39R 2SC5192/92R 39		
			MIN	TYP	MAX	MIN	TYP	MAX	MIN	TYP	MAX	MIN	TYP	MAX	MIN	TYP	MAX			
f_T	Gain Bandwidth Product at $V_{CE} = 1V, I_C = 3mA, f = 2.0GHz$	GHz	4	5		4.5	5		4	4.5		4	4.5		4	4.5				
f_T	Gain Bandwidth Product at $V_{CE} = 3V, I_C = 20mA, f = 2.0GHz$	GHz		10			9.5			9			8.5			9				
NF _{MIN}	Minimum Noise Figure at $V_{CE} = 1V, I_C = 3mA, f = 2.0GHz$	dB		1.7	2.5		1.7	2.5		1.7	2.5		1.7	2.5		1.7	2.5			
NF _{MIN}	Minimum Noise Figure at $V_{CE} = 3V, I_C = 7mA, f = 2.0GHz$	dB		1.5			1.5			1.5			1.5			1.5				
IS _{21E1} ²	Insertion Power Gain at $V_{CE} = 1V, I_C = 3mA, f = 2.0GHz$	dB	3.0	4.0		3.0	4.0		2.5	3.5		2.5	3.5		4.0	4.5				
IS _{21E2} ²	Insertion Power Gain at $V_{CE} = 3V, I_C = 20mA, f = 2.0GHz$	dB		8.5			8			6.5			6.5			9				
h _{FE}	Forward Current Gain ³ at $V_{CE} = 1V, I_C = 3mA$		80		160	80		160	80		160	80		160	80		160			
I _{CBO}	Collector Cutoff Current at $V_{CB} = 5V, I_E = 0mA$	nA			100			100			100			100			100			
I _{EBO}	Emitter Cutoff Current at $V_{EB} = 1V, I_C = 0mA$	nA			100			100			100			100			100			
C _{RE} ⁴	Feedback Capacitance at $V_{CB} = 1V, I_E = 0mA, f = 1MHz$	pF		0.65	0.8		0.7	0.8		0.75	0.85		0.75	0.85		0.65	0.8			
P _T	Total Power Dissipation	mW			150			125			150			200			200			
R _{TH(J-A)}	Thermal Resistance (Junction to Ambient)	°C/W			833			1000			833			625			625			
R _{TH(J-C)}	Thermal Resistance (Junction to Case)	°C/W																		

Notes:

1. Precaution: Devices are ESD sensitive. Use proper handling procedures.
2. Electronic Industrial Association of Japan.

3. Pulsed measurement, $PW \leq 350 \mu s$, duty cycle $\leq 2\%$.

4. The emitter terminal should be connected to the ground terminal of the 3 terminal capacitance bridge.

NE688 SERIES

ABSOLUTE MAXIMUM RATINGS¹ (T_A = 25°C)

SYMBOLS	PARAMETERS	UNITS	RATINGS
V _{CB0}	Collector to Base Voltage	V	9
V _{CE0}	Collector to Emitter Voltage	V	6
V _{EB0}	Emitter to Base Voltage	V	2.0
I _C	Collector Current	mA	100
T _J	Operating Junction Temperature	°C	150
T _{STG}	Storage Temperature	°C	-65 to +150

Notes:

1. Operation in excess of any one of these parameters may result in permanent damage.

TYPICAL PERFORMANCE CURVES (T_A = 25°C)

NE68818, NE68830
D.C. POWER DERATING CURVE

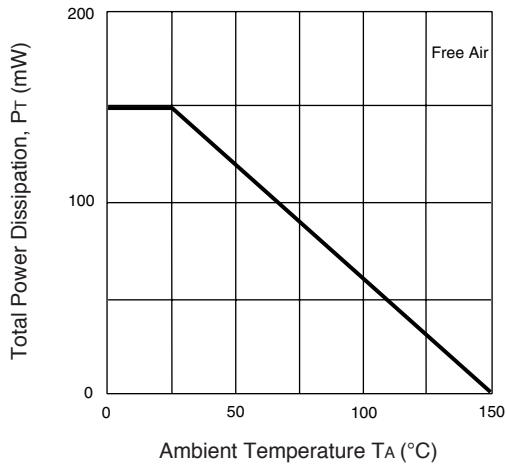

NE68819
D.C. POWER DERATING CURVE

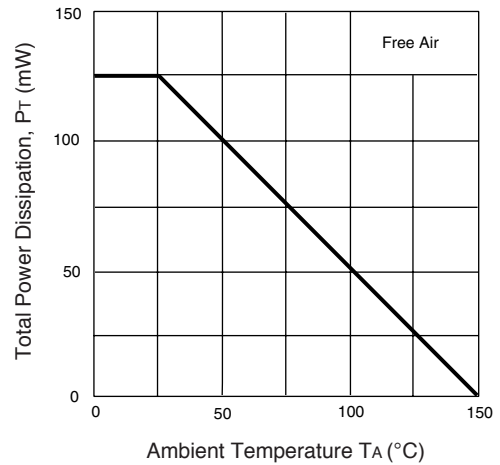

NE68833, NE68839
D.C. POWER DERATING CURVE

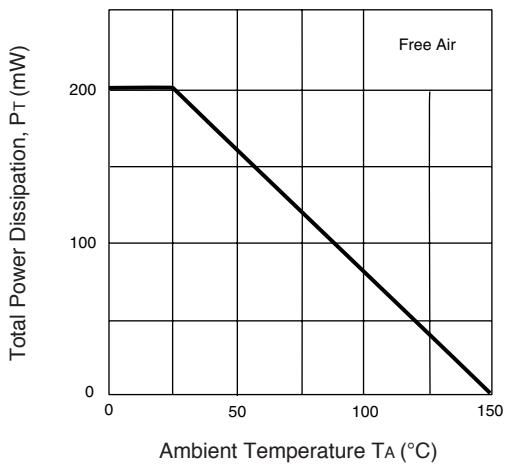

COLLECTOR CURRENT vs. COLLECTOR TO EMITTER VOLTAGE

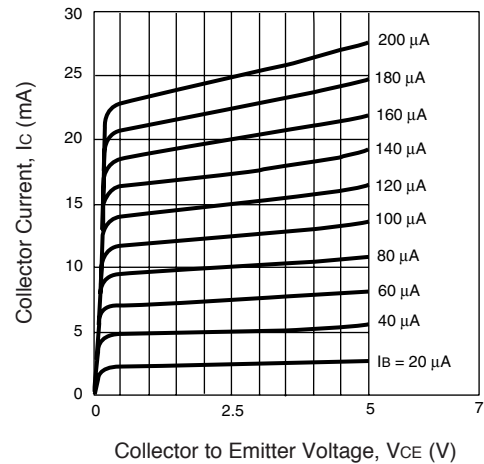

TYPICAL PERFORMANCE CURVES (TA = 25°C)

NE68833
INSERTION GAIN vs. COLLECTOR CURRENT

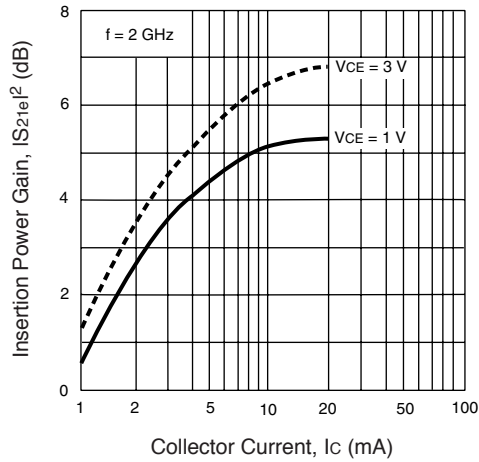

NE68833
NOISE FIGURE vs. COLLECTOR CURRENT

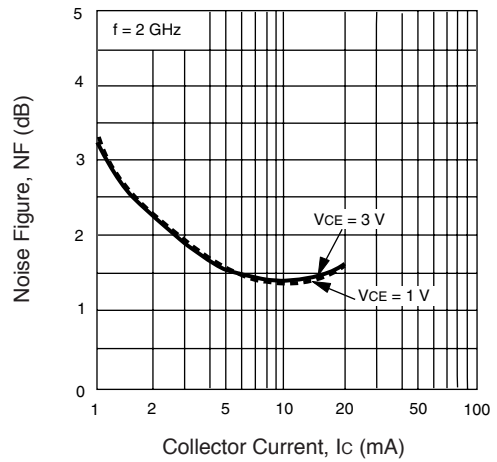

D.C. CURRENT GAIN vs. COLLECTOR CURRENT

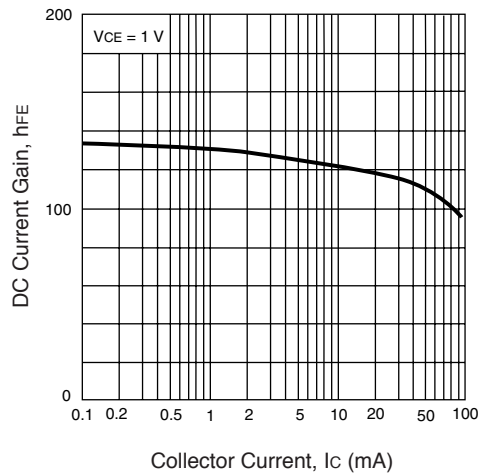

NE68839
GAIN BANDWIDTH PRODUCT vs. COLLECTOR CURRENT

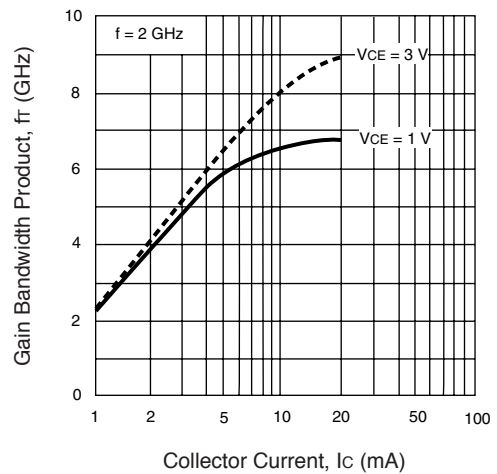

COLLECTOR CURRENT vs. BASE TO EMITTER VOLTAGE

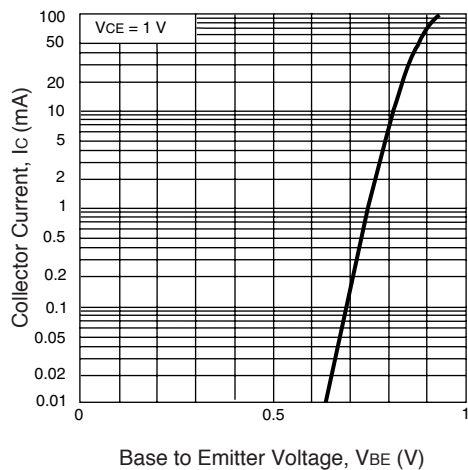

NE68830
FEED-BACK CAPACITANCE vs. COLLECTOR TO BASE VOLTAGE

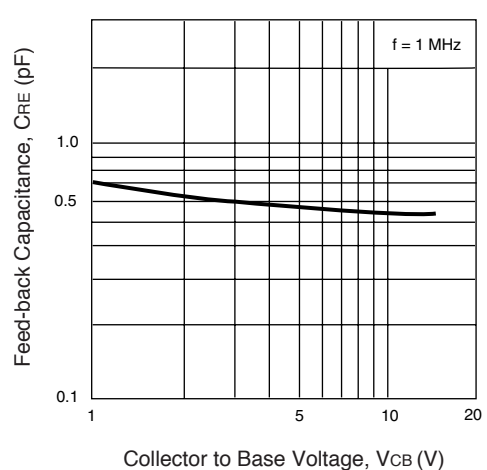

NE688 SERIES

TYPICAL SCATTERING PARAMETERS (TA = 25°C)

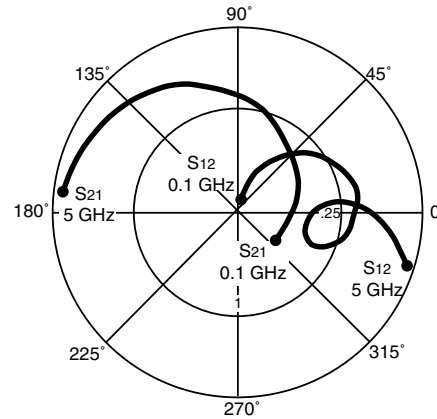
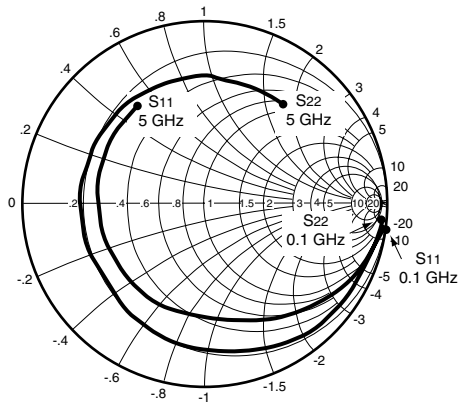

Coordinates in Ohms
Frequency in GHz
(VCE = 0.5 V, IC = 0.5 mA)

NE68819

VCE = 0.5 V, IC = 0.5 mA

FREQUENCY GHz	S11		S21		S12		S22		K	MAG ¹ (dB)
	MAG	ANG	MAG	ANG	MAG	ANG	MAG	ANG		
0.1	0.976	-16.300	1.892	164.300	0.061	77.700	0.990	-9.700	0.096	14.916
0.4	0.890	-62.900	1.635	125.300	0.203	47.300	0.892	-34.600	0.229	9.060
0.8	0.764	-108.300	1.250	86.900	0.283	18.500	0.757	-56.300	0.428	6.451
1.0	0.726	-125.500	1.098	72.100	0.294	8.100	0.716	-64.300	0.518	5.723
1.5	0.691	-159.300	0.859	43.500	0.276	-10.800	0.654	-81.500	0.722	4.931
2.0	0.685	174.200	0.715	22.600	0.233	-21.800	0.626	-97.700	0.946	4.870
2.5	0.689	150.800	0.618	6.500	0.184	-23.000	0.607	-115.400	1.257	2.208
3.0	0.693	129.200	0.554	-5.300	0.159	-8.700	0.592	-136.300	1.553	1.042

VCE = 1.0 V, IC = 1.0 mA

0.1	0.955	-18.200	3.606	164.000	0.047	77.800	0.985	-10.600	0.083	18.849
0.4	0.846	-68.100	2.975	127.000	0.153	47.200	0.851	-37.000	0.197	12.888
0.8	0.705	-114.900	2.125	92.400	0.205	21.600	0.685	-58.000	0.384	10.156
1.0	0.666	-132.000	1.825	79.400	0.210	13.300	0.636	-65.100	0.480	9.390
1.5	0.624	-165.000	1.363	53.900	0.200	0.700	0.565	-79.600	0.727	8.335
2.0	0.612	169.600	1.102	34.300	0.181	-3.100	0.529	-92.900	1.002	7.576
2.5	0.610	147.400	0.948	17.600	0.171	1.400	0.503	-107.600	1.241	4.481
3.0	0.612	127.000	0.850	3.100	0.189	9.500	0.478	-125.400	1.295	3.271
4.0	0.633	87.700	0.731	-22.000	0.312	7.300	0.464	-175.100	1.058	2.229
5.0	0.660	50.700	0.634	-42.500	0.434	-14.500	0.542	135.800	1.022	0.747

VCE = 3.0 V, IC = 3.0 mA

0.1	0.902	-25.000	9.548	160.300	0.035	75.900	0.964	-15.500	0.085	24.358
0.4	0.706	-86.100	6.729	119.100	0.098	44.700	0.708	-47.700	0.288	18.367
0.8	0.558	-133.100	4.185	89.200	0.123	29.300	0.500	-66.200	0.552	15.318
1.0	0.528	-148.700	3.477	78.800	0.129	26.300	0.448	-71.400	0.673	14.306
1.5	0.496	-177.500	2.465	57.900	0.143	23.100	0.383	-80.700	0.911	12.365
2.0	0.484	161.200	1.924	40.800	0.162	22.300	0.349	-89.300	1.068	9.158
2.5	0.480	142.700	1.613	25.100	0.189	21.100	0.324	-98.900	1.127	7.147
3.0	0.485	125.800	1.425	10.500	0.224	17.800	0.295	-112.300	1.115	5.973
4.0	0.518	91.200	1.187	-17.200	0.313	4.600	0.256	-159.100	1.030	4.721
5.0	0.579	56.600	0.985	-43.600	0.396	-14.900	0.342	147.600	0.973	3.957

VCE = 3.0 V, IC = 7.0 mA

0.1	0.786	-39.600	18.403	151.700	0.031	72.000	0.903	-25.500	0.118	27.735
0.4	0.542	-113.500	9.834	106.700	0.073	44.700	0.506	-65.400	0.487	21.294
0.8	0.450	-156.200	5.452	82.100	0.097	40.800	0.320	-82.200	0.797	17.498
1.0	0.434	-169.300	4.445	73.700	0.109	40.500	0.281	-86.600	0.894	16.104
1.5	0.420	167.100	3.072	55.700	0.143	38.100	0.231	-93.200	1.016	12.550
2.0	0.411	149.700	2.376	40.500	0.180	33.900	0.203	-99.000	1.069	9.601
2.5	0.410	134.000	1.974	25.900	0.220	27.700	0.179	-106.000	1.078	7.824
3.0	0.413	120.000	1.726	12.000	0.262	19.900	0.154	-119.300	1.067	6.606
4.0	0.460	89.000	1.412	-14.800	0.347	1.500	0.137	177.100	1.024	5.143
5.0	0.533	54.800	1.176	-40.600	0.413	-18.700	0.255	127.900	0.996	4.545

Note:

1. Gain Calculations:

$$MAG = \frac{|S_{21}|}{|S_{12}|} (K \pm \sqrt{K^2 - 1}). \text{ When } K \leq 1, \text{ MAG is undefined and MSG values are used. } MSG = \frac{|S_{21}|}{|S_{12}|}, K = \frac{1 + |\Delta|^2 - |S_{11}|^2 - |S_{22}|^2}{2 |S_{12} S_{21}|}, \Delta = S_{11} S_{22} - S_{21} S_{12}$$

MAG = Maximum Available Gain

MSG = Maximum Stable Gain

TYPICAL SCATTERING PARAMETERS (T_A = 25°C)

NE68819

V_{CE} = 3.0 V, I_c = 20 mA

FREQUENCY GHz	S ₁₁		S ₂₁		S ₁₂		S ₂₂		K	MAG ¹ (dB)
	MAG	ANG	MAG	ANG	MAG	ANG	MAG	ANG		
0.1	0.538	-68.800	32.261	136.000	0.023	64.800	0.741	-42.000	0.322	31.469
0.4	0.385	-146.900	11.973	94.900	0.053	57.300	0.302	-81.000	0.818	23.539
0.8	0.358	-179.500	6.233	76.200	0.090	57.600	0.191	-94.800	0.984	18.405
1.0	0.352	170.400	5.038	69.100	0.109	56.000	0.169	-98.300	1.014	15.931
1.5	0.345	152.000	3.447	53.400	0.157	49.400	0.139	-102.200	1.040	12.192
2.0	0.335	137.400	2.649	39.400	0.206	41.200	0.120	-104.900	1.048	9.756
2.5	0.334	124.900	2.189	25.600	0.255	32.000	0.101	-108.700	1.041	8.090
3.0	0.334	112.100	1.904	12.300	0.302	22.000	0.081	-124.300	1.036	6.829
4.0	0.396	83.800	1.544	-13.400	0.390	0.900	0.100	147.600	1.012	5.314
5.0	0.483	50.200	1.294	-38.000	0.453	-20.200	0.236	112.500	0.997	4.558

V_{CE} = 5.0 V, I_c = 10 mA

0.1	0.717	-44.700	22.801	147.800	0.029	68.600	0.867	-28.800	0.210	28.956
0.4	0.466	-119.600	10.924	103.000	0.063	49.200	0.442	-67.400	0.609	22.390
0.8	0.383	-161.000	5.912	80.300	0.093	48.100	0.279	-81.500	0.886	18.033
1.0	0.371	-173.600	4.804	72.300	0.108	47.600	0.246	-84.900	0.954	16.482
1.5	0.356	163.800	3.304	55.300	0.149	43.800	0.206	-89.800	1.029	12.415
2.0	0.349	146.600	2.545	40.600	0.192	37.800	0.183	-94.100	1.055	9.785
2.5	0.346	131.700	2.110	26.300	0.237	30.200	0.163	-99.400	1.055	8.057
3.0	0.349	118.200	1.842	12.700	0.282	21.500	0.140	-111.400	1.045	6.851
4.0	0.403	87.800	1.503	-13.400	0.369	1.900	0.113	-179.400	1.015	5.349
5.0	0.485	53.100	1.262	-38.900	0.437	-18.800	0.229	127.200	0.992	4.606

Note:

1. Gain Calculations:

$$\text{MAG} = \frac{|S_{21}|}{|S_{12}|} (K \pm \sqrt{K^2 - 1}). \text{ When } K \leq 1, \text{ MAG is undefined and MSG values are used. } \text{MSG} = \frac{|S_{21}|}{|S_{12}|}, K = \frac{1 + |\Delta|^2 - |S_{11}|^2 - |S_{22}|^2}{2 |S_{12}| |S_{21}|}, \Delta = S_{11} S_{22} - S_{21} S_{12}$$

MAG = Maximum Available Gain

MSG = Maximum Stable Gain

NE688 SERIES

TYPICAL SCATTERING PARAMETERS (T_A = 25°C)

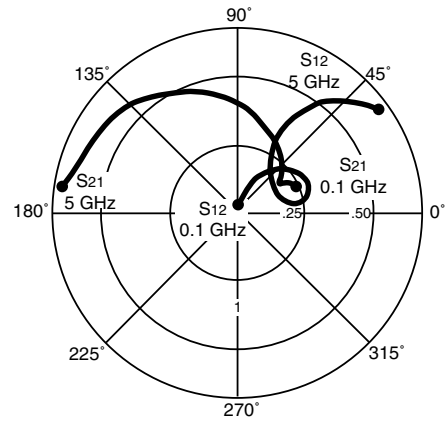
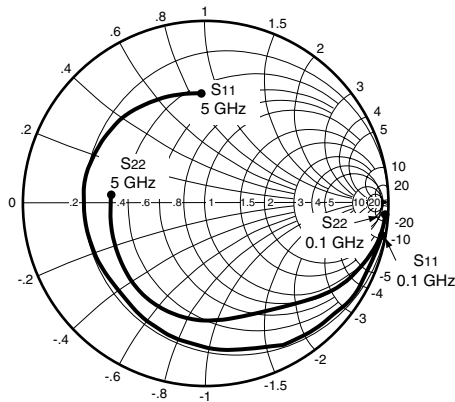

Coordinates in Ohms
Frequency in GHz
(V_{CE} = 0.5 V, I_C = 0.5 mA)

NE68830

V_{CE} = 0.5 V, I_C = 0.5 mA

FREQUENCY GHz	S ₁₁		S ₂₁		S ₁₂		S ₂₂		K	MAG ¹ (dB)
	MAG	ANG	MAG	ANG	MAG	ANG	MAG	ANG		
0.1	0.977	-15.600	1.794	165.200	0.063	78.200	0.989	-8.600	0.101	14.545
0.4	0.880	-61.200	1.560	127.600	0.209	50.900	0.883	-29.700	0.247	8.730
0.8	0.749	-103.800	1.199	92.400	0.282	26.900	0.745	-47.000	0.457	6.286
1.0	0.710	-119.300	1.057	79.900	0.287	19.000	0.706	-53.300	0.549	5.662
1.5	0.670	-148.700	0.832	57.200	0.249	7.800	0.654	-67.800	0.777	5.239
2.0	0.667	-171.700	0.691	43.200	0.185	11.100	0.641	-82.200	1.079	4.012
2.5	0.669	168.000	0.595	35.800	0.160	39.600	0.636	-97.500	1.352	2.162
3.0	0.663	148.500	0.545	34.900	0.240	62.300	0.624	-113.300	1.179	0.998

V_{CE} = 1.0 V, I_C = 1.0 mA

0.1	0.956	-16.900	3.478	165.200	0.050	78.400	0.983	-9.700	0.092	18.424
0.4	0.824	-67.100	2.847	128.900	0.157	50.900	0.834	-32.200	0.224	12.585
0.8	0.672	-110.800	2.021	97.700	0.202	31.500	0.661	-48.100	0.444	10.002
1.0	0.630	-126.100	1.739	86.900	0.205	26.700	0.613	-53.400	0.555	9.285
1.5	0.583	-154.600	1.306	67.000	0.188	25.000	0.550	-64.600	0.849	8.418
2.0	0.571	-176.300	1.067	53.000	0.174	36.300	0.528	-75.600	1.116	5.800
2.5	0.569	165.000	0.918	42.700	0.201	53.800	0.520	-87.500	1.149	4.251
3.0	0.562	147.100	0.821	36.200	0.274	63.000	0.513	-100.100	1.056	3.316
4.0	0.554	115.300	0.745	28.400	0.477	56.800	0.476	-128.100	0.969	1.936
5.0	0.562	93.000	0.751	20.000	0.635	39.900	0.439	-166.000	0.985	0.729

V_{CE} = 3.0 V, I_C = 3.0 mA

0.1	0.869	-24.100	9.277	160.200	0.035	76.600	0.957	-14.600	0.114	24.233
0.4	0.635	-85.100	6.331	119.900	0.097	51.200	0.673	-40.700	0.380	18.147
0.8	0.484	-127.600	3.861	94.600	0.124	45.600	0.471	-51.200	0.690	14.933
1.0	0.449	-141.200	3.196	86.700	0.134	46.800	0.426	-53.800	0.814	13.775
1.5	0.415	-166.200	2.270	71.200	0.162	52.300	0.371	-59.200	1.003	11.109
2.0	0.402	174.800	1.800	59.500	0.199	57.200	0.352	-65.500	1.064	8.018
2.5	0.401	159.600	1.523	49.600	0.246	60.100	0.348	-72.700	1.043	6.648
3.0	0.396	144.900	1.339	41.200	0.304	60.300	0.347	-80.800	1.005	5.989
4.0	0.411	118.700	1.114	27.800	0.434	54.500	0.332	-100.400	0.947	4.094
5.0	0.470	99.800	1.000	15.700	0.560	43.200	0.289	-136.400	0.931	2.518

V_{CE} = 3.0 V, I_C = 7.0 mA

0.1	0.721	-40.400	17.900	149.800	0.032	70.700	0.873	-25.700	0.206	27.477
0.4	0.434	-111.800	8.737	106.900	0.075	55.700	0.453	-55.300	0.650	20.663
0.8	0.350	-150.000	4.773	87.500	0.112	60.000	0.293	-61.900	0.915	16.296
1.0	0.336	-161.700	3.890	81.400	0.132	61.700	0.263	-63.300	0.973	14.694
1.5	0.318	-178.800	2.710	69.200	0.184	63.300	0.230	-67.100	1.035	10.542
2.0	0.315	163.400	2.124	59.100	0.240	62.700	0.221	-71.900	1.035	8.321
2.5	0.313	150.200	1.779	50.200	0.297	60.700	0.222	-77.600	1.021	6.882
3.0	0.310	137.900	1.559	42.400	0.355	57.600	0.226	-84.600	1.004	6.059
4.0	0.322	116.200	1.305	29.000	0.470	49.300	0.220	-103.900	0.973	4.435
5.0	0.397	102.200	1.160	16.500	0.570	38.800	0.194	-144.300	0.954	3.086

See notes on previous page.

TYPICAL SCATTERING PARAMETERS (T_A = 25°C)

NE68830

V_{CE} = 3.0 V, I_C = 20 mA

FREQUENCY GHz	S ₁₁		S ₂₁		S ₁₂		S ₂₂		K	MAG ¹ (dB)
	MAG	ANG	MAG	ANG	MAG	ANG	MAG	ANG		
0.1	0.472	-66.200	29.896	134.700	0.024	69.600	0.707	-41.100	0.408	30.954
0.4	0.313	-143.700	10.607	97.700	0.061	67.800	0.276	-66.500	0.884	22.403
0.8	0.289	-171.000	5.532	83.500	0.110	70.700	0.173	-70.800	0.994	17.015
1.0	0.285	-179.400	4.472	78.800	0.135	70.500	0.154	-72.100	1.012	14.543
1.5	0.283	-165.900	3.076	68.600	0.196	68.100	0.134	-75.600	1.025	10.998
2.0	0.280	-153.300	2.400	59.900	0.256	64.400	0.129	-79.500	1.022	8.816
2.5	0.278	-143.200	2.003	51.900	0.314	60.300	0.132	-83.700	1.013	7.348
3.0	0.271	-131.700	1.747	44.400	0.371	55.800	0.138	-89.700	1.006	6.272
4.0	0.285	-114.200	1.440	31.100	0.473	45.900	0.134	-110.400	0.992	4.835
5.0	0.365	-103.100	1.272	18.100	0.553	35.300	0.124	-169.400	0.981	3.618

V_{CE} = 5.0 V, I_C = 10 mA

0.1	0.656	-44.300	22.050	146.100	0.029	70.900	0.835	-29.100	0.264	28.810
0.4	0.380	-119.100	9.847	104.200	0.067	59.500	0.400	-57.400	0.732	21.672
0.8	0.311	-155.500	5.283	86.600	0.107	64.100	0.258	-62.400	0.949	16.935
1.0	0.299	-166.800	4.287	81.100	0.129	65.200	0.232	-63.600	0.989	15.216
1.5	0.291	-173.200	2.964	69.500	0.183	65.300	0.204	-67.100	1.028	11.073
2.0	0.289	-157.500	2.315	60.200	0.239	63.500	0.197	-71.700	1.028	8.840
2.5	0.289	-145.100	1.932	51.600	0.294	60.600	0.201	-76.800	1.016	7.393
3.0	0.285	-131.600	1.686	43.900	0.349	57.000	0.207	-83.200	1.006	6.382
4.0	0.307	-110.900	1.388	30.500	0.453	48.400	0.205	-100.900	0.982	4.863
5.0	0.385	-98.500	1.225	17.800	0.543	38.300	0.173	-142.100	0.965	3.533

Note:

1. Gain Calculations:

$$\text{MAG} = \frac{|S_{21}|}{|S_{12}|} (K \pm \sqrt{K^2 - 1}). \text{ When } K \leq 1, \text{ MAG is undefined and MSG values are used. } \text{MSG} = \frac{|S_{21}|}{|S_{12}|}, K = \frac{1 + |\Delta|^2 - |S_{11}|^2 - |S_{22}|^2}{2 |S_{12}| |S_{21}|}, \Delta = S_{11} S_{22} - S_{21} S_{12}$$

MAG = Maximum Available Gain

MSG = Maximum Stable Gain

NE688 SERIES

TYPICAL SCATTERING PARAMETERS (T_A = 25°C)

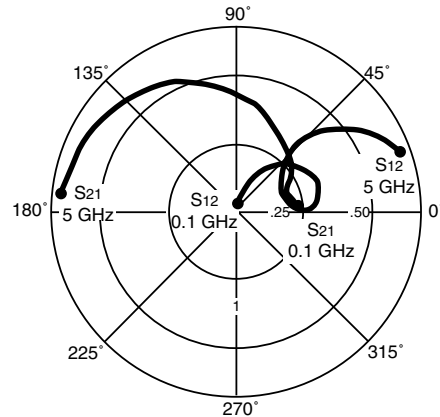
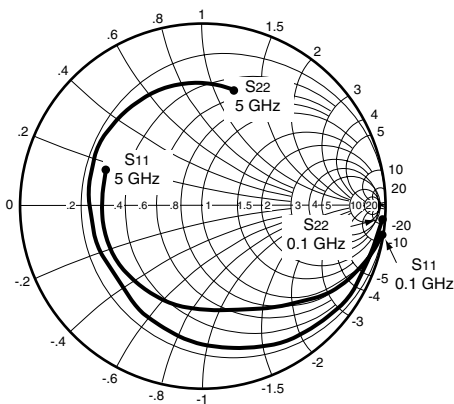

Coordinates in Ohms
Frequency in GHz
(V_{CE} = 0.5 V, I_c = 0.5 mA)

NE68833

V_{CE} = 0.5 V, I_c = 0.5 mA

FREQUENCY GHz	S ₁₁		S ₂₁		S ₁₂		S ₂₂		K	MAG ¹ (dB)
	MAG	ANG	MAG	ANG	MAG	ANG	MAG	ANG		
0.1	0.971	-15.100	1.775	164.000	0.065	79.000	0.989	-8.700	0.117	14.363
0.4	0.877	-59.900	1.588	127.800	0.215	50.900	0.883	-30.200	0.261	8.684
0.8	0.723	-105.400	1.237	90.500	0.295	25.300	0.729	-48.600	0.491	6.225
1.0	0.683	-122.900	1.101	76.900	0.303	16.500	0.682	-55.300	0.581	5.603
1.5	0.640	-158.100	0.871	51.800	0.265	2.900	0.609	-71.400	0.824	5.168
2.0	0.644	174.400	0.717	35.000	0.199	3.900	0.584	-88.400	1.167	3.092
2.5	0.669	151.300	0.612	25.500	0.171	27.800	0.578	-107.300	1.428	1.649
3.0	0.682	131.300	0.544	22.100	0.243	47.700	0.580	-126.900	1.244	0.525

V_{CE} = 1.0 V, I_c = 1.0 mA

0.1	0.960	-16.300	3.468	165.600	0.051	78.200	0.983	-9.800	0.098	18.325
0.4	0.821	-66.100	2.890	128.500	0.163	51.000	0.835	-33.200	0.235	12.487
0.8	0.650	-112.800	2.090	95.600	0.215	30.000	0.649	-50.700	0.459	9.877
1.0	0.602	-130.600	1.803	83.800	0.219	24.200	0.592	-56.500	0.571	9.156
1.5	0.555	-165.100	1.360	61.400	0.203	20.000	0.508	-69.500	0.865	8.260
2.0	0.556	168.200	1.106	44.800	0.190	28.300	0.474	-83.200	1.122	5.529
2.5	0.576	146.900	0.938	32.500	0.215	41.900	0.464	-99.100	1.162	3.959
3.0	0.592	128.400	0.826	24.000	0.282	48.500	0.468	-116.200	1.068	3.074
4.0	0.618	98.100	0.724	13.600	0.459	40.800	0.483	-151.100	0.968	1.979
5.0	0.626	75.400	0.700	4.000	0.593	24.000	0.500	174.500	0.990	0.720

V_{CE} = 1.0 V, I_c = 3.0 mA

0.1	0.877	-28.400	9.241	157.900	0.048	73.200	0.937	-19.300	0.128	22.845
0.4	0.607	-94.900	5.850	113.900	0.122	46.800	0.599	-53.600	0.411	16.808
0.8	0.462	-141.800	3.462	87.200	0.154	40.500	0.382	-70.400	0.731	13.518
1.0	0.437	-157.700	2.859	78.500	0.166	40.900	0.331	-75.500	0.853	12.361
1.5	0.423	173.800	2.032	61.200	0.202	43.700	0.265	-87.200	1.029	8.987
2.0	0.437	152.600	1.616	47.500	0.246	45.300	0.239	-100.400	1.079	6.461
2.5	0.461	136.300	1.361	35.700	0.299	44.700	0.237	-115.600	1.062	5.066
3.0	0.481	121.800	1.197	26.300	0.356	42.000	0.250	-131.300	1.033	4.151
4.0	0.523	98.200	1.005	10.500	0.473	32.300	0.294	-162.400	0.981	3.273
5.0	0.571	78.400	0.882	-2.600	0.566	19.400	0.349	167.000	0.974	1.927

V_{CE} = 3.0 V, I_c = 3.0 mA

0.1	0.892	-23.800	9.321	160.400	0.037	75.000	0.954	-15.000	0.137	24.013
0.4	0.629	-83.800	6.328	118.600	0.102	51.000	0.666	-42.700	0.399	17.927
0.8	0.446	-129.900	3.868	91.300	0.133	44.500	0.454	-55.000	0.719	14.636
1.0	0.409	-146.800	3.204	82.400	0.144	44.900	0.403	-58.200	0.841	13.473
1.5	0.379	-178.400	2.277	65.100	0.177	48.200	0.336	-65.900	1.017	10.300
2.0	0.389	158.300	1.797	51.400	0.218	50.600	0.305	-75.600	1.066	7.588
2.5	0.410	140.300	1.507	39.500	0.270	50.800	0.293	-88.100	1.043	6.192
3.0	0.432	125.000	1.315	29.800	0.327	48.500	0.293	-102.600	1.009	5.474
4.0	0.484	100.300	1.087	13.600	0.449	39.400	0.310	-134.200	0.945	3.840
5.0	0.533	79.800	0.947	-0.100	0.558	26.400	0.342	-168.400	0.939	2.297

TYPICAL SCATTERING PARAMETERS (T_A = 25°C)

NE68833

V_{CE} = 3.0 V, I_C = 7.0 mA

FREQUENCY GHz	S ₁₁		S ₂₁		S ₁₂		S ₂₂		K	MAG ¹ (dB)
	MAG	ANG	MAG	ANG	MAG	ANG	MAG	ANG		
0.1	0.738	-38.900	17.561	148.600	0.035	72.200	0.874	-25.500	0.226	27.005
0.4	0.422	-108.100	8.799	106.000	0.078	55.800	0.453	-55.900	0.661	20.523
0.8	0.317	-152.000	4.793	85.000	0.119	58.000	0.283	-63.900	0.921	16.051
1.0	0.304	-166.400	3.908	78.000	0.140	58.700	0.248	-66.300	0.978	14.458
1.5	0.302	168.000	2.707	64.000	0.196	57.900	0.202	-74.100	1.033	10.291
2.0	0.317	148.300	2.120	52.100	0.254	55.100	0.180	-84.800	1.036	8.051
2.5	0.342	133.600	1.769	41.800	0.311	50.900	0.173	-99.100	1.022	6.632
3.0	0.358	121.600	1.541	32.300	0.368	45.900	0.177	-115.100	1.008	5.662
4.0	0.406	101.800	1.282	16.200	0.471	34.800	0.204	-148.600	0.976	4.349
5.0	0.471	83.500	1.117	1.100	0.557	22.300	0.252	175.600	0.964	3.022

V_{CE} = 3.0 V, I_C = 20 mA

0.1	0.479	-65.600	29.593	133.500	0.026	65.900	0.692	-41.600	0.448	30.562
0.4	0.276	-141.300	10.351	95.700	0.066	67.400	0.266	-67.200	0.898	21.954
0.8	0.252	-176.800	5.382	80.200	0.119	68.300	0.165	-73.600	0.999	16.554
1.0	0.251	171.500	4.352	74.600	0.146	67.100	0.146	-77.100	1.014	14.006
1.5	0.265	151.700	2.993	62.700	0.212	62.500	0.121	-88.700	1.024	10.543
2.0	0.289	136.500	2.324	52.200	0.275	56.900	0.110	-104.300	1.021	8.387
2.5	0.313	124.100	1.932	42.400	0.335	50.800	0.114	-122.300	1.012	6.930
3.0	0.332	113.100	1.678	33.800	0.390	44.500	0.130	-139.600	1.007	5.840
4.0	0.378	96.000	1.384	17.900	0.486	32.000	0.175	-170.800	0.992	4.545
5.0	0.445	80.700	1.201	3.100	0.556	19.400	0.231	160.200	0.983	3.345

V_{CE} = 5.0 V, I_C = 10 mA

0.1	0.686	-44.200	22.023	145.500	0.030	67.500	0.828	-29.500	0.293	28.658
0.4	0.356	-115.200	9.698	102.500	0.071	59.600	0.390	-57.900	0.756	21.354
0.8	0.271	-158.000	5.191	83.500	0.116	62.500	0.246	-64.000	0.958	16.508
1.0	0.262	-172.200	4.212	77.100	0.139	62.400	0.217	-66.100	0.997	14.815
1.5	0.266	161.900	2.912	64.000	0.199	60.200	0.178	-73.800	1.028	10.631
2.0	0.285	143.600	2.269	52.800	0.258	56.100	0.158	-84.900	1.029	8.398
2.5	0.312	129.300	1.886	42.600	0.316	51.300	0.153	-99.700	1.017	6.962
3.0	0.332	117.100	1.639	33.700	0.370	45.800	0.158	-116.500	1.008	5.901
4.0	0.381	97.900	1.351	17.500	0.469	34.200	0.187	-150.600	0.986	4.595
5.0	0.449	81.900	1.175	2.500	0.548	22.000	0.230	176.200	0.970	3.313

Note:

1. Gain Calculations:

$$\text{MAG} = \frac{|S_{21}|}{|S_{12}|} (K \pm \sqrt{K^2 - 1}). \text{ When } K \leq 1, \text{ MAG is undefined and MSG values are used. } \text{MSG} = \frac{|S_{21}|}{|S_{12}|}, K = \frac{1 + |\Delta|^2 - |S_{11}|^2 - |S_{22}|^2}{2 |S_{12}| |S_{21}|}, \Delta = S_{11} S_{22} - S_{21} S_{12}$$

MAG = Maximum Available Gain

MSG = Maximum Stable Gain

NE688 SERIES

TYPICAL SCATTERING PARAMETERS (T_A = 25°C)

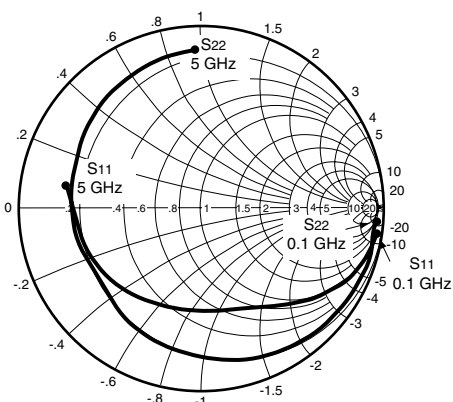

Coordinates in Ohms
Frequency in GHz
(V_{CE} = 0.5 V, I_C = 0.5 mA)

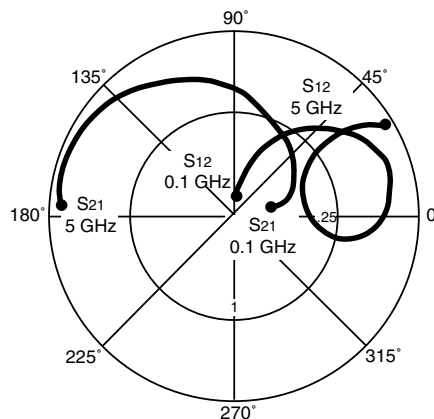

NE68839

V_{CE} = 0.5 V, I_C = 0.5 mA

FREQUENCY GHz	S ₁₁		S ₂₁		S ₁₂		S ₂₂		K	MAG ¹ (dB)
	MAG	ANG	MAG	ANG	MAG	ANG	MAG	ANG		
0.1	0.989	-15.100	1.756	167.700	0.057	80.500	0.990	-7.000	0.047	14.886
0.4	0.899	-58.000	1.616	131.900	0.205	53.400	0.898	-26.300	0.227	8.967
0.8	0.768	-105.900	1.310	95.000	0.303	26.900	0.746	-43.100	0.419	6.358
1.0	0.727	-125.800	1.169	80.700	0.319	16.700	0.690	-49.600	0.493	5.640
1.5	0.694	-164.800	0.921	52.700	0.300	-2.200	0.595	-65.200	0.669	4.871
2.0	0.716	167.500	0.735	32.300	0.239	-13.100	0.569	-82.500	0.859	4.879
2.5	0.755	147.100	0.601	18.900	0.168	-10.700	0.570	-102.800	1.140	3.262
3.0	0.788	131.400	0.490	11.300	0.136	13.200	0.593	-123.900	1.430	1.669

V_{CE} = 1.0 V, I_C = 1.0 mA

0.1	0.968	-17.300	3.482	166.900	0.047	79.200	0.986	-8.600	0.054	18.697
0.4	0.847	-65.200	3.022	132.100	0.159	52.200	0.850	-30.300	0.199	12.789
0.8	0.697	-115.200	2.251	98.700	0.220	28.700	0.656	-47.500	0.386	10.100
1.0	0.660	-134.900	1.936	86.400	0.229	20.900	0.587	-53.700	0.470	9.271
1.5	0.631	-173.000	1.448	62.300	0.213	9.900	0.477	-67.500	0.704	8.324
2.0	0.655	160.900	1.129	43.900	0.184	8.800	0.438	-83.000	0.955	7.879
2.5	0.692	142.400	0.933	30.100	0.166	18.400	0.433	-101.400	1.147	5.168
3.0	0.728	127.900	0.770	19.800	0.179	31.500	0.451	-121.300	1.194	3.675
4.0	0.790	106.200	0.588	8.600	0.271	39.000	0.534	-157.100	0.985	3.364
5.0	0.828	90.000	0.502	3.700	0.360	30.600	0.624	175.200	0.947	1.444

V_{CE} = 3.0 V, I_C = 3.0 mA

0.1	0.894	-24.500	9.342	161.900	0.035	76.700	0.961	-13.600	0.087	24.264
0.4	0.682	-84.100	6.782	122.300	0.100	50.000	0.693	-41.400	0.324	18.314
0.8	0.524	-135.700	4.250	93.900	0.129	38.200	0.455	-56.300	0.606	15.178
1.0	0.501	-154.100	3.523	84.500	0.136	36.700	0.390	-60.700	0.724	14.134
1.5	0.503	172.800	2.472	66.200	0.154	37.500	0.295	-71.900	0.938	12.055
2.0	0.542	151.200	1.886	51.600	0.174	39.900	0.251	-87.400	1.052	8.957
2.5	0.586	135.700	1.542	39.500	0.201	41.700	0.239	-106.600	1.068	7.260
3.0	0.626	123.800	1.297	29.300	0.233	42.000	0.254	-126.500	1.049	6.108
4.0	0.704	105.600	0.988	13.200	0.303	38.000	0.335	-159.600	0.959	5.133
5.0	0.766	90.900	0.799	0.700	0.366	30.000	0.442	176.400	0.901	3.391

V_{CE} = 3.0 V, I_C = 7.0 mA

0.1	0.763	-36.500	18.110	153.100	0.029	72.400	0.901	-22.600	0.164	27.955
0.4	0.501	-110.300	9.906	110.000	0.072	51.400	0.496	-55.500	0.544	21.386
0.8	0.421	-157.600	5.514	87.400	0.101	50.300	0.288	-68.500	0.835	17.371
1.0	0.418	-172.900	4.478	80.100	0.115	51.100	0.239	-73.600	0.918	15.904
1.5	0.449	161.400	3.060	65.400	0.151	51.200	0.171	-90.700	1.016	12.285
2.0	0.494	144.100	2.319	53.100	0.188	49.600	0.148	-116.000	1.047	9.591
2.5	0.539	131.600	1.887	42.300	0.224	46.700	0.159	-141.800	1.043	7.985
3.0	0.583	121.700	1.583	33.100	0.258	43.300	0.193	-161.300	1.032	6.790
4.0	0.662	105.800	1.216	17.100	0.319	35.300	0.284	-174.500	0.986	5.811
5.0	0.732	92.400	0.988	3.800	0.367	26.600	0.384	158.700	0.940	4.301

See notes on previous page.

TYPICAL SCATTERING PARAMETERS (T_A = 25°C)

NE68839

VCE = 5.0 V, Ic = 5.0 mA

FREQUENCY GHz	S ₁₁		S ₂₁		S ₁₂		S ₂₂		K	MAG ¹ (dB)
	MAG	ANG	MAG	ANG	MAG	ANG	MAG	ANG		
0.1	0.840	-29.900	14.218	158.000	0.029	74.900	0.937	-17.100	0.114	26.904
0.4	0.574	-94.600	9.003	116.400	0.078	51.400	0.598	-46.200	0.444	20.623
0.8	0.440	-144.900	5.274	91.200	0.105	46.300	0.372	-58.000	0.750	17.010
1.0	0.425	-162.500	4.315	83.200	0.116	46.700	0.315	-61.700	0.854	15.705
1.5	0.443	167.400	2.978	67.400	0.147	47.900	0.232	-72.500	0.991	13.066
2.0	0.489	147.700	2.263	54.300	0.178	47.900	0.190	-89.500	1.045	9.746
2.5	0.534	133.000	1.846	43.100	0.211	46.500	0.177	-111.500	1.048	8.074
3.0	0.575	122.900	1.549	33.600	0.244	44.400	0.190	-133.600	1.040	6.802
4.0	0.660	106.200	1.190	17.500	0.308	38.000	0.264	-166.000	0.974	5.870
5.0	0.728	92.400	0.962	4.100	0.362	29.700	0.365	172.800	0.925	4.245

VCE = 5.0 V, Ic = 10 mA

0.1	0.703	-41.700	22.638	149.200	0.027	69.700	0.865	-26.400	0.232	29.235
0.4	0.441	-117.800	11.095	106.400	0.064	54.500	0.432	-59.100	0.640	22.389
0.8	0.378	-163.300	6.015	85.900	0.095	55.900	0.246	-71.500	0.901	18.015
1.0	0.383	-177.500	4.863	79.200	0.112	56.300	0.203	-77.000	0.956	16.377
1.5	0.418	158.400	3.313	65.600	0.153	55.200	0.145	-97.200	1.020	12.494
2.0	0.468	142.100	2.505	53.900	0.193	52.200	0.133	-126.000	1.035	9.985
2.5	0.512	130.300	2.034	43.700	0.231	48.300	0.153	-152.300	1.034	8.325
3.0	0.559	120.900	1.708	34.800	0.265	44.100	0.191	-170.400	1.024	7.135
4.0	0.638	105.400	1.312	19.300	0.325	35.200	0.282	168.100	0.993	6.061
5.0	0.712	92.600	1.066	5.700	0.370	26.100	0.377	154.100	0.954	4.596

Note:

1. Gain Calculations:

$$\text{MAG} = \frac{|S_{21}|}{|S_{12}|} (K \pm \sqrt{K^2 - 1}). \text{ When } K \leq 1, \text{ MAG is undefined and MSG values are used. } \text{MSG} = \frac{|S_{21}|}{|S_{12}|}, K = \frac{1 + |\Delta|^2 - |S_{11}|^2 - |S_{22}|^2}{2 |S_{12}| |S_{21}|}, \Delta = S_{11} S_{22} - S_{21} S_{12}$$

MAG = Maximum Available Gain

MSG = Maximum Stable Gain

SCHEMATIC

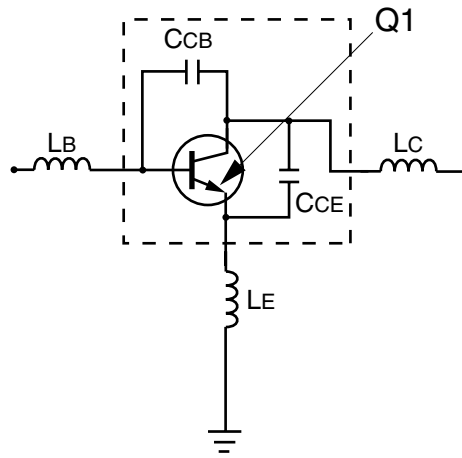

BJT NONLINEAR MODEL PARAMETERS (1)

Parameters	Q1	Parameters	Q1
IS	3.8e-16	MJC	0.48
BF	135.7	XCJC	0.56
NF	1	CJS	0
VAF	28	VJS	0.75
IKF	0.6	MJS	0
ISE	3.8e-15	FC	0.75
NE	1.49	TF	11.0e-12
BR	12.3	XTF	0.36
NR	1.1	VTF	0.65
VAR	3.5	ITF	0.61
IKR	0.06	PTF	50
ISC	3.5e-16	TR	0.032e-9
NC	1.62	EG	1.11
RE	0.4	XTB	0
RB	6.14	XTI	3
RBM	3.5	KF	0
IRB	0.001	AF	1
RC	4.2		
CJE	0.796e-12		
VJE	0.71		
MJE	0.38		
CJC	0.549e-12		
VJC	0.65		

(1) Gummel-Poon Model

UNITS

Parameter	Units
time	seconds
capacitance	farads
inductance	henries
resistance	ohms
voltage	volts
current	amps

ADDITIONAL PARAMETERS

Parameters	68800
CCB	0.24e-12
CCE	0.27e-12
LB	0.72e-9
Lc	0.51e-9
LE	0.19e-9

MODEL RANGE

Frequency: 0.1 to 10.0 GHz
 Bias: VCE = 1 V to 3 V, IC = 1 mA to 10 mA
 P1dB: 12.5 dBm at VCE = 3 V, IC = 10 mA, 2 GHz
 Date: 10/3/96

NE68818 NONLINEAR MODEL

SCHEMATIC

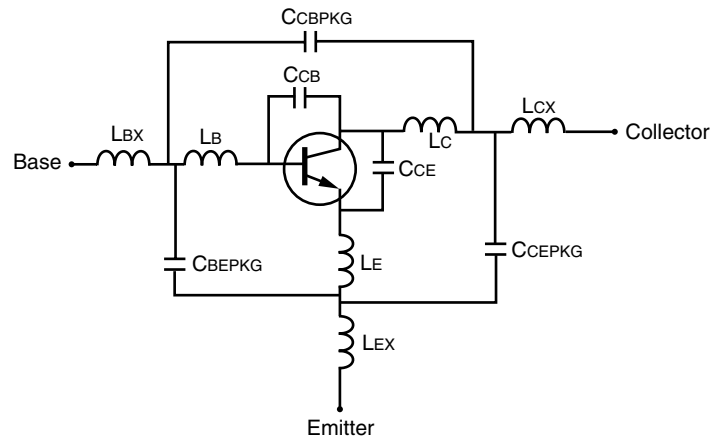

BJT NONLINEAR MODEL PARAMETERS (1)

Parameters	Q1	Parameters	Q1
IS	3.8e-16	MJC	0.48
BF	135.7	XCJC	0.56
NF	1	CJS	0
VAF	28	VJS	0.75
IKF	0.6	MJS	0
ISE	3.8e-15	FC	0.75
NE	1.49	TF	11e-12
BR	12.3	XTF	0.36
NR	1.1	VTF	0.65
VAR	3.5	ITF	0.61
IKR	0.06	PTF	50
ISC	3.5e-16	TR	32e-12
NC	1.62	EG	1.11
RE	0.4	XTB	0
RB	6.14	XTI	3
RBM	3.5	KF	1.5e-14
IRB	0.001	AF	1.22
RC	4.2		
CJE	0.796e-12		
VJE	0.71		
MJE	0.38		
CJC	0.549e-12		
VJC	0.65		

(1) Gummel-Poon Model

UNITS

Parameter	Units
time	seconds
capacitance	farads
inductance	henries
resistance	ohms
voltage	volts
current	amps

ADDITIONAL PARAMETERS

Parameters	68818
CCB	0.24e-12
CCE	0.27e-12
LB	0.9e-9
LC	0.52e-9
LE	0.7e-9
CCBPKG	0.001e-12
CCEPKG	0.07e-12
CBEPKG	0.11e-12
LBX	0.18e-9
LCX	0.18e-9
LEX	0.09e-9

MODEL RANGE

Frequency: 0.5 to 6.0 GHz
 Bias: VCE = 1 V to 5 V, IC = 1 mA to 10 mA
 Date: 5/97

SCHEMATIC

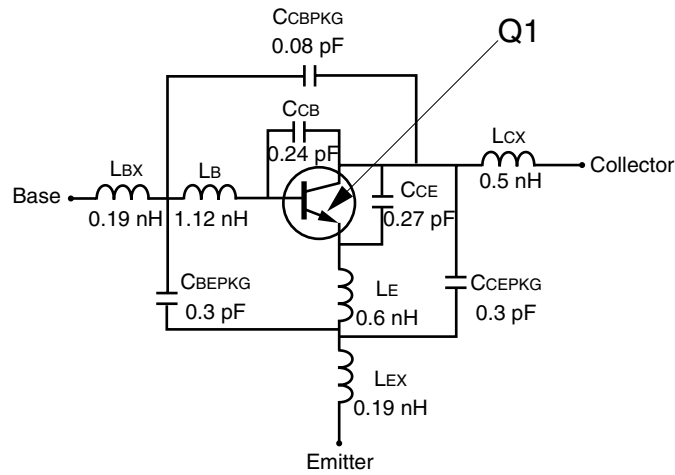

BJT NONLINEAR MODEL PARAMETERS (1)

Parameters	Q1	Parameters	Q1
IS	3.8e-16	MJC	0.48
BF	135.7	XCJC	0.56
NF	1	CJS	0
VAF	28	VJS	0.75
IKF	0.6	MJS	0
ISE	3.8e-15	FC	0.75
NE	1.49	TF	11.0e-12
BR	12.3	XTF	0.36
NR	1.1	VTF	0.65
VAR	3.5	ITF	0.61
IKR	0.06	PTF	50
ISC	3.5e-16	TR	32e-12
NC	1.62	EG	1.11
RE	0.4	XTB	0
RB	6.14	XTI	3
RBM	3.5	KF	1.5e-14
IRB	0.001	AF	1.22
RC	4.2		
CJE	0.796e-12		
VJE	0.71		
MJE	0.38		
CJC	0.549e-12		
VJC	0.65		

(1) Gummel-Poon Model

UNITS

Parameter	Units
time	seconds
capacitance	farads
inductance	henries
resistance	ohms
voltage	volts
current	amps

ADDITIONAL PARAMETERS

Parameters	68819
CCB	0.24e-12
CCE	0.27e-12
LB	1.12e-9
LE	0.6e-9
CCBPKG	0.08e-12
CCEPKG	0.3e-12
CBEPKG	0.3e-12
LBX	0.19e-9
LCX	0.5e-9
LEX	0.19e-9

MODEL RANGE

Frequency: 0.1 to 3 GHz
 Bias: VCE = 1 V to 3 V, IC = 1 mA to 10 mA
 Date: 3/20/97

NE68830 NONLINEAR MODEL

SCHEMATIC

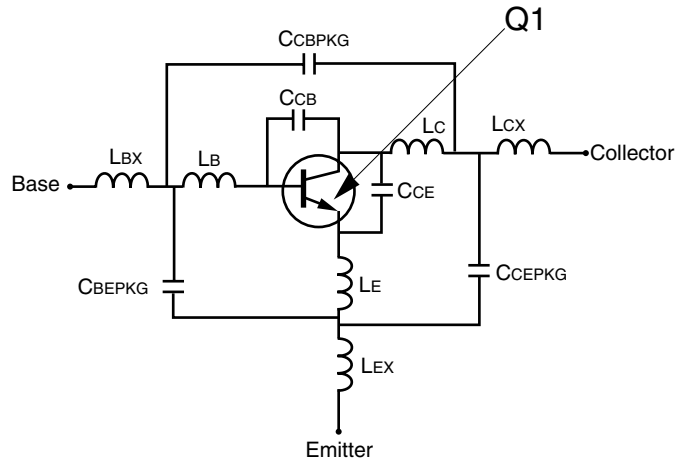

BJT NONLINEAR MODEL PARAMETERS (1)

Parameters	Q1	Parameters	Q1
IS	3.8e-16	MJC	0.48
BF	135.7	XCJC	0.56
NF	1	CJS	0
VAF	28	VJS	0.75
IKF	0.6	MJS	0
ISE	3.8e-15	FC	0.75
NE	1.49	TF	11e-12
BR	12.3	XTF	0.36
NR	1.1	VTF	0.65
VAR	3.5	ITF	0.61
IKR	0.06	PTF	50
ISC	3.5e-16	TR	32e-12
NC	1.62	EG	1.11
RE	0.4	XTB	0
RB	6.14	XTI	3
RBM	3.5	KF	0
IRB	0.001	AF	1
RC	4.2		
CJE	0.796e-12		
VJE	0.71		
MJE	0.38		
CJC	0.549e-12		
VJC	0.65		

UNITS

Parameter	Units
time	seconds
capacitance	farads
inductance	henries
resistance	ohms
voltage	volts
current	amps

ADDITIONAL PARAMETERS

Parameters	68830
CCB	0.24e-12
CCE	0.27e-12
LB	0.5e-9
LE	0.86e-9
CCBPKG	0.08e-12
CCEPKG	0.04e-12
CBEPKG	0.04e-12
LBX	0.2e-9
LCX	0.1e-9
LEX	0.2e-9

MODEL RANGE

Frequency: 0.05 to 3.0 GHz
 Bias: VCE = 1 V to 5 V, IC = 1 mA to 10 mA
 Date: 10/11/96

(1) Gummel-Poon Model

NE68833 NONLINEAR MODEL

SCHEMATIC

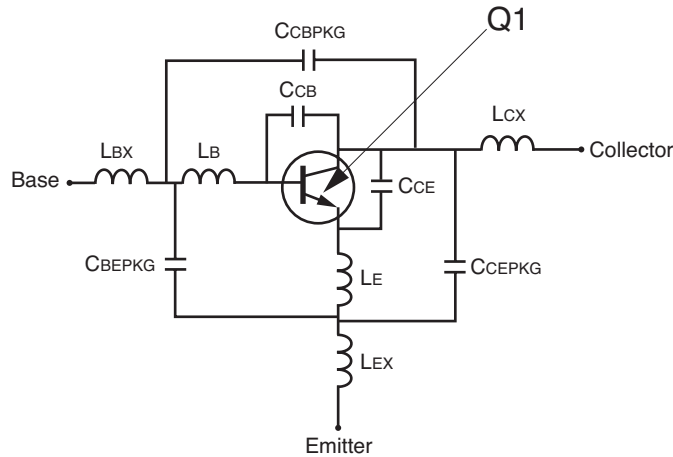

BJT NONLINEAR MODEL PARAMETERS (1)

Parameters	Q1	Parameters	Q1
IS	3.8e-16	MJC	0.48
BF	135.7	XCJC	0.56
NF	1	CJS	0
VAF	28	VJS	0.75
IKF	0.6	MJS	0
ISE	3.8e-15	FC	0.75
NE	1.49	TF	11e-12
BR	12.3	XTF	0.36
NR	1.1	VTF	0.65
VAR	3.5	ITF	0.61
IKR	0.06	PTF	50
ISC	3.5e-16	TR	32e-12
NC	1.62	EG	1.11
RE	0.4	XTB	0
RB	6.14	XTI	3
RBM	3.5	KF	1.5e-14
IRB	0.001	AF	1.22
RC	4.2		
CJE	0.796e-12		
VJE	0.71		
MJE	0.38		
CJC	0.549e-12		
VJC	0.65		

(1) Gummel-Poon Model

UNITS

Parameter	Units
time	seconds
capacitance	farads
inductance	henries
resistance	ohms
voltage	volts
current	amps

ADDITIONAL PARAMETERS

Parameters	68833
CCB	0.24e-12
CCE	0.27e-12
LB	0.77e-9
LE	0.95e-9
CCBPKG	0.15e-12
CCEPKG	0.1e-12
CBEPKG	0.1e-12
LBX	0.3e-9
LCX	0.4e-9
LEX	0.3e-9

MODEL RANGE

Frequency: 0.05 to 5.0 GHz
 Bias: $V_{CE} = 1\text{ V to }5\text{ V}$, $I_C = 1\text{ mA to }10\text{ mA}$
 Date: 8/03

NE68839 NONLINEAR MODEL

SCHEMATIC

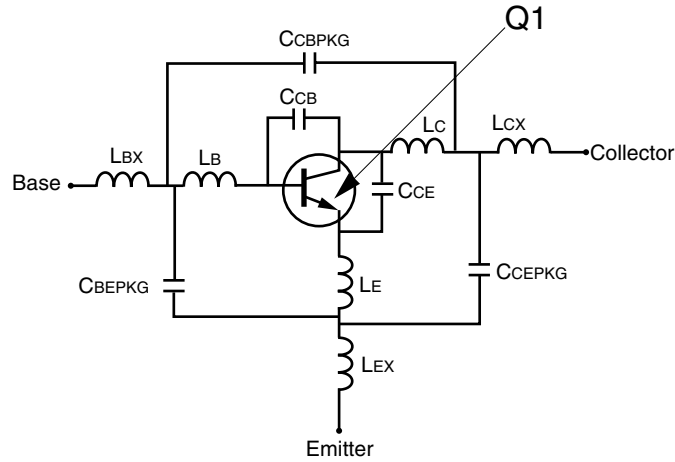

BJT NONLINEAR MODEL PARAMETERS (1)

Parameters	Q1	Parameters	Q1
IS	3.8e-16	MJC	0.48
BF	135.7	XCJC	0.56
NF	1	CJS	0
VAF	28	VJS	0.75
IKF	0.6	MJS	0
ISE	3.8e-15	FC	0.75
NE	1.49	TF	11e-12
BR	12.3	XTF	0.36
NR	1.1	VTF	0.65
VAR	3.5	ITF	0.61
IKR	0.06	PTF	50
ISC	3.5e-16	TR	0.032e-9
NC	1.62	EG	1.11
RE	0.4	XTB	0
RB	6.14	XTI	3
RBM	3.5	KF	0
IRB	0.001	AF	1
RC	4.2		
CJE	0.796e-12		
VJE	0.71		
MJE	0.38		
CJC	0.549e-12		
VJC	0.65		

(1) Gummel-Poon Model

UNITS

Parameter	Units
time	seconds
capacitance	farads
inductance	henries
resistance	ohms
voltage	volts
current	amps

ADDITIONAL PARAMETERS

Parameters	68839
CcB	0.24e-12
CcE	0.27e-12
Lb	0.9e-9
Lc	0.47e-9
Le	0.6e-9
CcBPKG	0.085e-12
CcEPKG	0.07e-12
CbEPKG	0.01e-12
LbX	0.39e-9
LcX	0.39e-9
LEx	0.2e-9

MODEL RANGE

Frequency: 0.05 to 5.0 GHz
 Bias: VCE = 0.5 V to 5 V, IC = 0.5 mA to 10 mA
 Date: 10/3/96

OUTLINE DIMENSIONS (Units in mm)

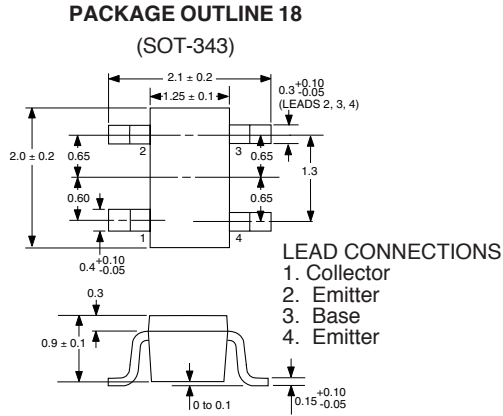

OUTLINE 18
RECOMMENDED P.C.B. LAYOUT

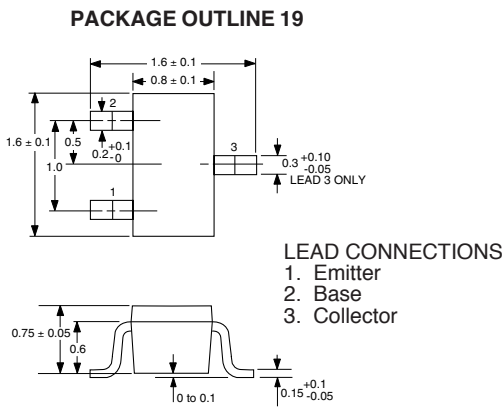
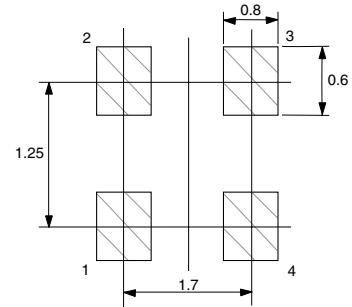

OUTLINE 19
RECOMMENDED P.C.B. LAYOUT

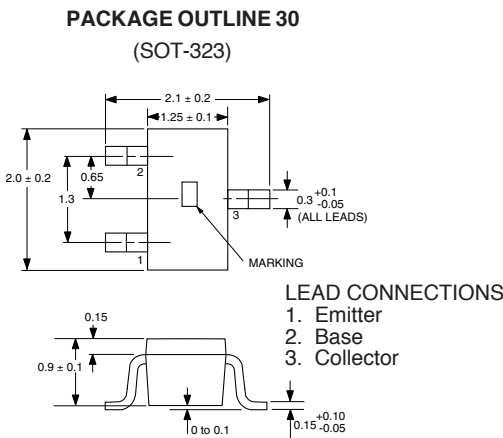
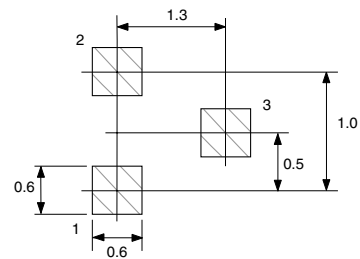

OUTLINE 30
RECOMMENDED P.C.B. LAYOUT

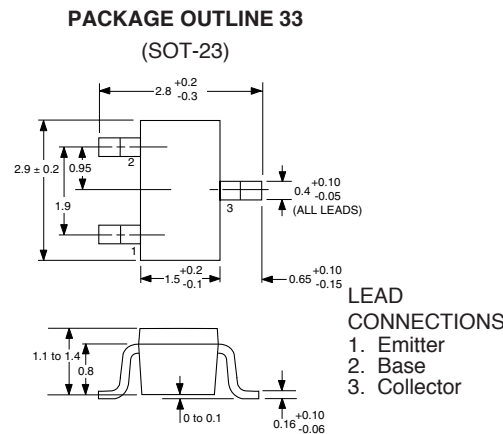
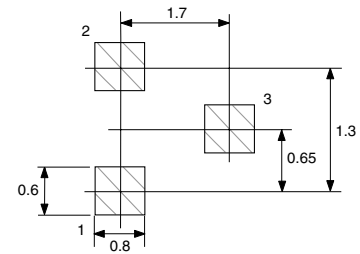

OUTLINE 33
RECOMMENDED P.C.B. LAYOUT

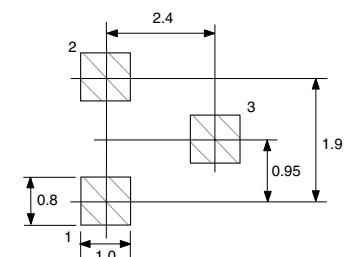

OUTLINE DIMENSIONS (Units in mm)

PACKAGE OUTLINE 39
(SOT-143)

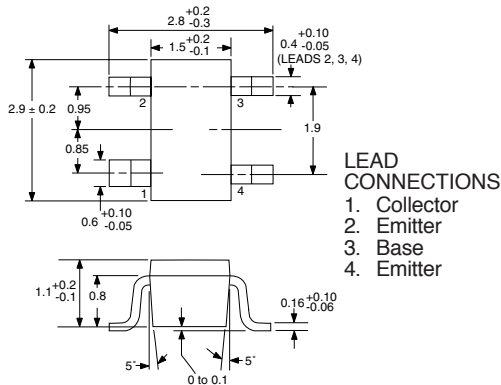

OUTLINE 39
RECOMMENDED P.C.B. LAYOUT

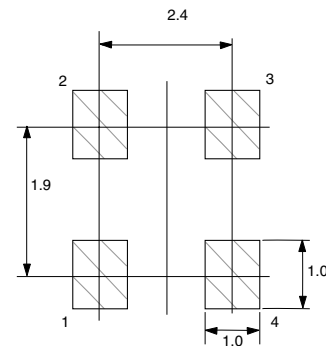

PACKAGE OUTLINE 39R

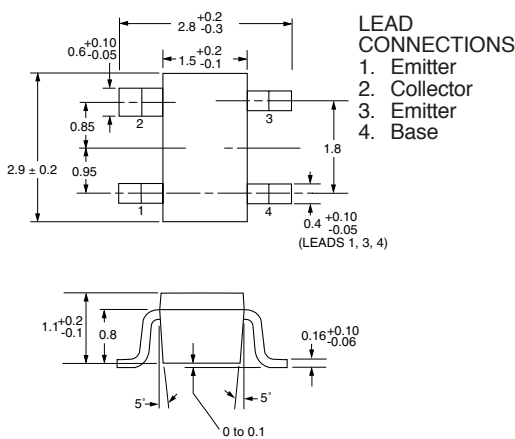

OUTLINE 39R
RECOMMENDED P.C.B. LAYOUT

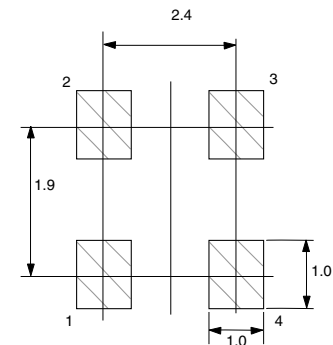

ORDERING INFORMATION

PART NUMBER	QUANTITY	PACKAGING
NE68800	100	Waffle Pack
NE68818-T1-A	3000	Tape & Reel
NE68819-T1-A	3000	Tape & Reel
NE68830-T1-A	3000	Tape & Reel
NE68833-T1-A	3000	Tape & Reel
NE68839-T1-A	3000	Tape & Reel
NE68839R-T1	3000	Tape & Reel

Note:

- Lead material: Cu
Lead plating: PbSn

Life Support Applications

These NEC products are not intended for use in life support devices, appliances, or systems where the malfunction of these products can reasonably be expected to result in personal injury. The customers of CEL using or selling these products for use in such applications do so at their own risk and agree to fully indemnify CEL for all damages resulting from such improper use or sale.

CEL California Eastern Laboratories, Your source for NEC RF, Microwave, Optoelectronic, and Fiber Optic Semiconductor Devices.

4590 Patrick Henry Drive • Santa Clara, CA 95054-1817 • (408) 988-3500 • FAX (408) 988-0279 • www.cel.com

DATA SUBJECT TO CHANGE WITHOUT NOTICE

05/18/2005

Subject: Compliance with EU Directives

CEL certifies, to its knowledge, that semiconductor and laser products detailed below are compliant with the requirements of European Union (EU) Directive 2002/95/EC Restriction on Use of Hazardous Substances in electrical and electronic equipment (RoHS) and the requirements of EU Directive 2003/11/EC Restriction on Penta and Octa BDE.

CEL Pb-free products have the same base part number with a suffix added. The suffix –A indicates that the device is Pb-free. The –AZ suffix is used to designate devices containing Pb which are exempted from the requirement of RoHS directive (*). In all cases the devices have Pb-free terminals. All devices with these suffixes meet the requirements of the RoHS directive.

This status is based on CEL’s understanding of the EU Directives and knowledge of the materials that go into its products as of the date of disclosure of this information.

Restricted Substance per RoHS	Concentration Limit per RoHS (values are not yet fixed)	Concentration contained in CEL devices	
		-A	-AZ
Lead (Pb)	< 1000 PPM	Not Detected	(*)
Mercury	< 1000 PPM	Not Detected	
Cadmium	< 100 PPM	Not Detected	
Hexavalent Chromium	< 1000 PPM	Not Detected	
PBB	< 1000 PPM	Not Detected	
PBDE	< 1000 PPM	Not Detected	

If you should have any additional questions regarding our devices and compliance to environmental standards, please do not hesitate to contact your local representative.

Important Information and Disclaimer: Information provided by CEL on its website or in other communications concerning the substance content of its products represents knowledge and belief as of the date that it is provided. CEL bases its knowledge and belief on information provided by third parties and makes no representation or warranty as to the accuracy of such information. Efforts are underway to better integrate information from third parties. CEL has taken and continues to take reasonable steps to provide representative and accurate information but may not have conducted destructive testing or chemical analysis on incoming materials and chemicals. CEL and CEL suppliers consider certain information to be proprietary, and thus CAS numbers and other limited information may not be available for release.

In no event shall CEL’s liability arising out of such information exceed the total purchase price of the CEL part(s) at issue sold by CEL to customer on an annual basis.

See CEL Terms and Conditions for additional clarification of warranties and liability.

Looking for pricing, stock, or lifecycle information?

Click below to explore more details on WIN SOURCE:

 [View NE68830-T1-A on WIN SOURCE](#)

 [CEL Information](#)

Optimize Your Supply Chain with WIN SOURCE Solutions

-  Global Sourcing Solution
-  Obsolete Management
-  Cost Control Management
-  Shortage Management
-  Alternative Solution
-  Excess Inventory Management