

NANOPOWER SUPERVISORY CIRCUITS

FEATURES

- ESD Protection Exceeds 2000 V Per MIL-STD-883, Method 3015; Exceeds 200 V Using Machine Model (C = 200 pF, R = 0)
- Supply Current of 220 nA (Typ)
- Precision Supply Voltage Supervision Range: 1.8 V, 2.5 V, 3 V, 3.3 V
- Power-On Reset Generator With Selectable Delay Time of 10 ms or 200 ms
- Push/Pull $\overline{\text{RESET}}$ Output (TPS3836), RESET Output (TPS3837), or Open-Drain RESET Output (TPS3838)
- Manual Reset
- 5-Pin SOT-23 Package

SUPPORTS DEFENSE, AEROSPACE, AND MEDICAL APPLICATIONS

- Controlled Baseline
- One Assembly/Test Site
- One Fabrication Site
- Available in Military (–55°C/125°C) Temperature Range⁽¹⁾
- Extended Product Life Cycle
- Extended Product-Change Notification
- Product Traceability

APPLICATIONS

- Applications Using Automotive Low-Power DSPs, Microcontrollers, or Microprocessors
- Battery-Powered Equipment
- Intelligent Instruments
- Wireless Communication Systems
- Automotive Systems

(1) Custom temperature ranges available

DESCRIPTION

The TPS3836, TPS3837, TPS3838 families of supervisory circuits provide circuit initialization and timing supervision, primarily for digital signal processing (DSP) and processor-based systems.

During power on, $\overline{\text{RESET}}$ is asserted when the supply voltage V_{DD} becomes higher than 1.1 V. Thereafter, the supervisory circuit monitors V_{DD} and keeps $\overline{\text{RESET}}$ output active as long as V_{DD} remains below the threshold voltage (V_{IT}). An internal timer delays the return of the output to the inactive state (high) to ensure proper system reset. The delay time starts after V_{DD} has risen above V_{IT} .

When CT is connected to GND, a fixed delay time of typical 10 ms is asserted. When connected to V_{DD} , the delay time is typically 200 ms.

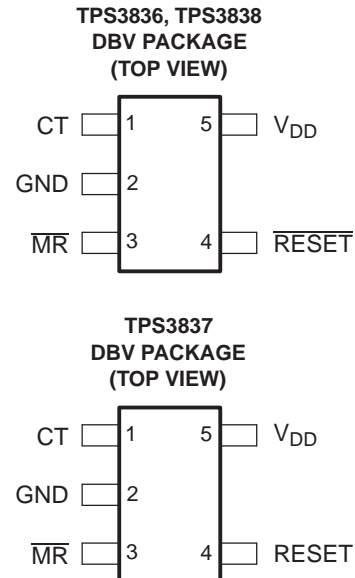

Please be aware that an important notice concerning availability, standard warranty, and use in critical applications of Texas Instruments semiconductor products and disclaimers thereto appears at the end of this data sheet.

When the supply voltage drops below V_{IT} , the output becomes active (low) again.

All the devices of this family have a fixed-sense V_{IT} set by an internal voltage divider.

The TPS3836 has an active-low push-pull $\overline{\text{RESET}}$ output. The TPS3837 has active-high push-pull RESET, and the TPS3838 integrates an active-low open-drain RESET output.

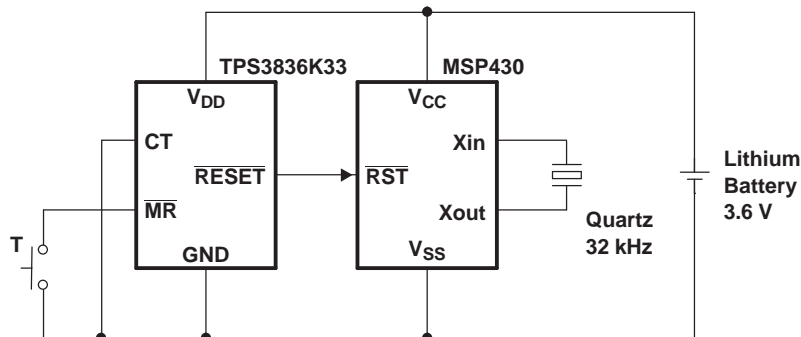

Figure 1. Typical Operating Circuit

The product spectrum is designed for supply voltages of 1.8 V, 2.5 V, 3 V, and 3.3 V. The circuits are available in a 5-pin SOT-23 package. The TPS3836, TPS3837, and TPS3838 families are characterized for operation over a temperature range of -55°C to 125°C .

ORDERING INFORMATION

T _A	ORDERABLE PART NUMBER ⁽¹⁾	THRESHOLD VOLTAGE	SYMBOL
-55°C to 125°C	TPS3836J25MDBVTEP	2.25 V	PKRM
	TPS3836L30MDBVREP	2.64 V	BTX
	TPS3837K33MDBVREP	2.93 V	PKZM

(1) DBVR indicates reel of 3000 parts, DBVT indicates tape of 250 parts.

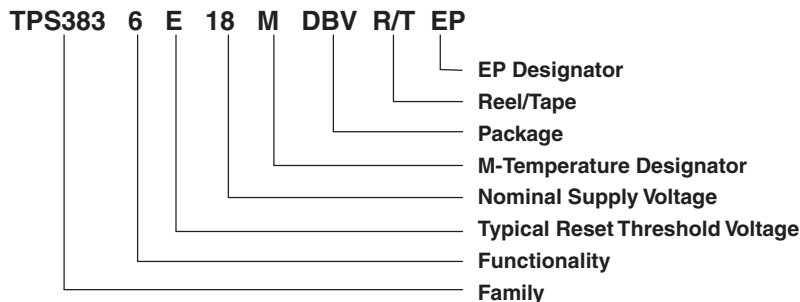
ORDERING INFORMATION

FUNCTION TABLE

\overline{MR}	$V_{DD} > V_{IT}$	$\overline{RESET}^{(1)}$	$RESET^{(2)}$
L	0	L	H
L	1	L	H
H	0	L	H
H	1	H	L

(1) TPS3836 and TPS3838

(2) TPS3837

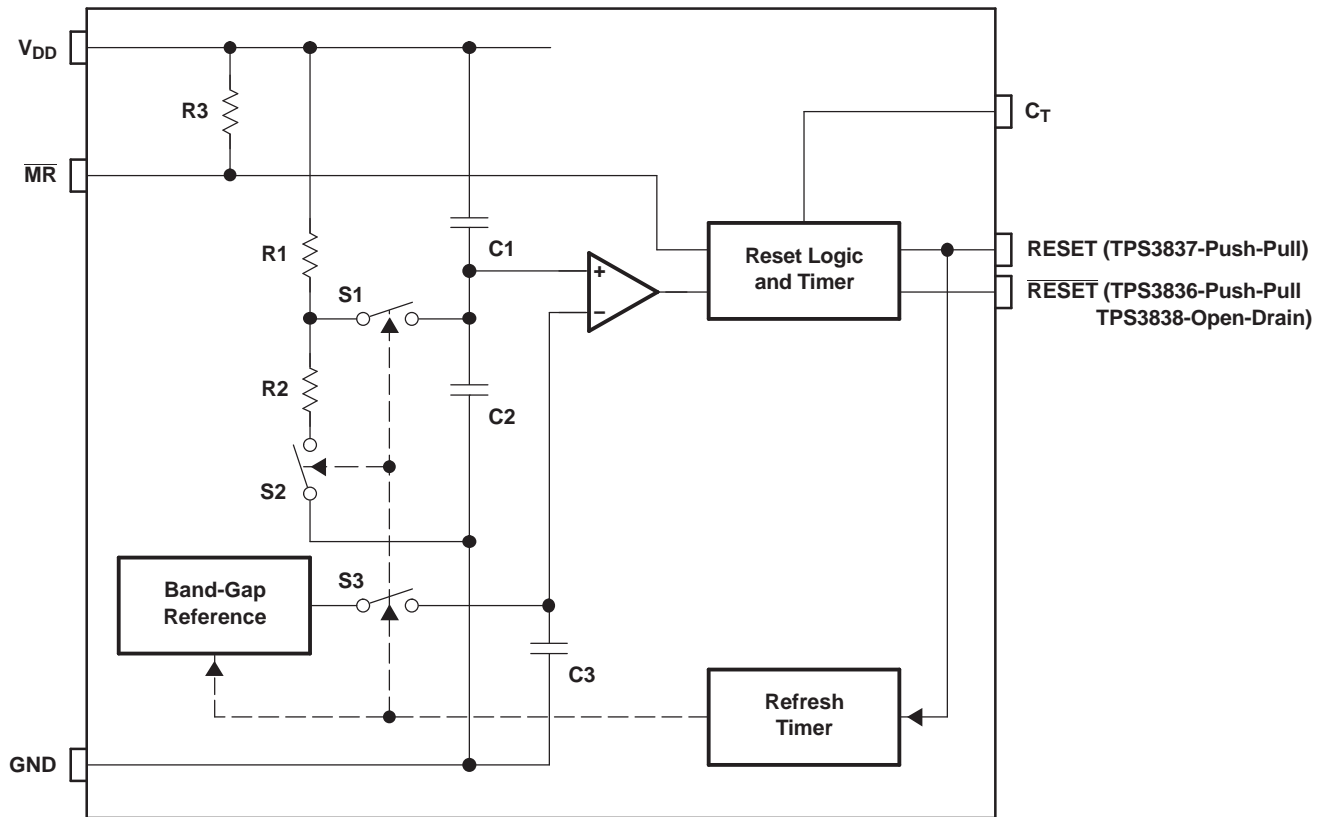
FUNCTIONAL BLOCK DIAGRAM

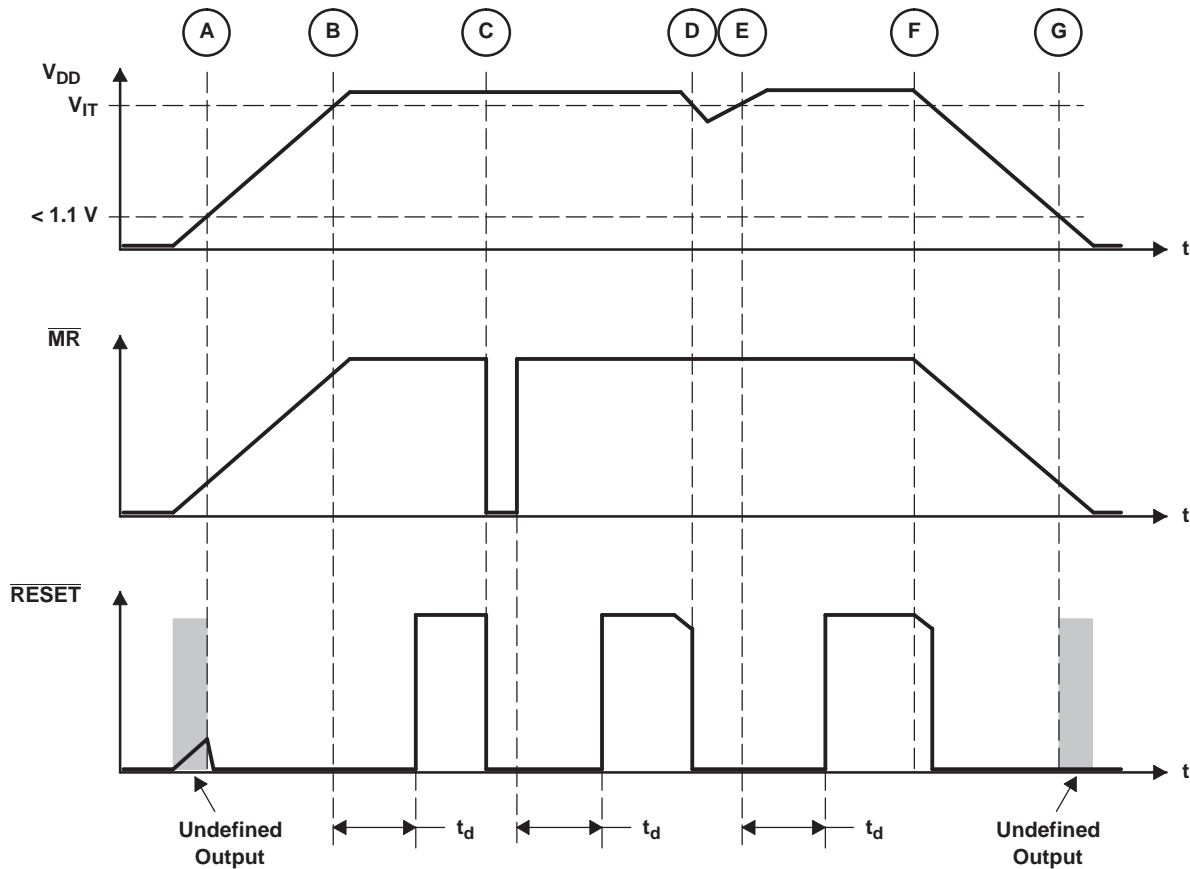

TIMING DIAGRAM

Absolute Maximum Ratings

 over operating free-air temperature range (unless otherwise noted) ⁽¹⁾

V_{DD}	Supply voltage ⁽²⁾	7 V
	All other pins ⁽²⁾	-0.3 V to 7 V
I_{OL}	Maximum low output current	5 mA
I_{OH}	Maximum high output current	-5 mA
I_{IK}	Input clamp current ($V_I < 0$ or $V_I > V_{DD}$)	± 10 mA
I_{OK}	Output clamp current ($V_O < 0$ or $V_O > V_{DD}$)	± 10 mA
T_A	Operating free-air temperature range	-55°C to 125°C
T_{stg}	Storage temperature range	-65°C to 150°C
T_J	Maximum junction temperature	150°C
	Soldering temperature	260°C

- (1) Stresses beyond those listed under *absolute maximum ratings* may cause permanent damage to the device. These are stress ratings only, and functional operation of the device at these or any other conditions beyond those indicated under *recommended operating conditions* is not implied. Exposure to absolute-maximum-rated conditions for extended periods may affect device reliability.
- (2) All voltage values are with respect to GND. For reliable operation, the device must not be continuously operated at 7 V for more than $t = 1000$ h.

Thermal Resistance Table

RESISTANCE	HIGH	LOW
θ_{JC} (°C/W)	130.9	148.1
θ_{JA} (°C/W)	205.6	347

Recommended Operating Conditions

		MIN	MAX	UNIT
V_{DD}	Supply voltage	1.6	6	V
V_I	Input voltage	0	$V_{DD} + 0.3$	V
V_{IH}	High-level input voltage	$0.7 \times V_{DD}$		V
V_{IL}	Low-level input voltage		$0.3 \times V_{DD}$	V
$\Delta t/\Delta v$	Input transition rise and fall rate at \overline{MR}		100	ns/V
T_A	Operating free-air temperature	-55	125	°C

Electrical Characteristics

over recommended operating conditions (unless otherwise noted)

PARAMETER		TEST CONDITIONS		MIN	TYP	MAX	UNIT	
V_{OH}	High-level output voltage	\overline{RESET} (TPS3836)	$V_{DD} = 3.3\text{ V}, I_{OH} = -2\text{ mA}$	$0.8 \times V_{DD}$			V	
			$V_{DD} = 6\text{ V}, I_{OH} = -3\text{ mA}$					
		\overline{RESET} (TPS3837)	$V_{DD} = 2\text{ V}, I_{OH} = -1\text{ mA}$					
			$V_{DD} = 3.3\text{ V}, I_{OH} = -2\text{ mA}$					
V_{OL}	Low-level output voltage	\overline{RESET} (TPS3836/8)	$V_{DD} = 2\text{ V}, I_{OL} = 1\text{ mA}$			0.4	V	
			$V_{DD} = 3.3\text{ V}, I_{OL} = 2\text{ mA}$					
		\overline{RESET} (TPS3837)	$V_{DD} = 3.3\text{ V}, I_{OL} = 2\text{ mA}$					
			$V_{DD} = 6\text{ V}, I_{OL} = 3\text{ mA}$					
Power-up reset voltage ⁽¹⁾		TPS3836/8	$V_{DD} \geq 1.1\text{ V}, I_{OL} = 50\text{ }\mu\text{A}$			0.2	V	
		TPS3837	$V_{DD} \geq 1.1\text{ V}, I_{OH} = -50\text{ }\mu\text{A}$	$T_A = 25^\circ\text{C}$	$0.8 \times V_{DD}$			
						$0.6 \times V_{DD}$		
V_{IT}	Negative-going input threshold voltage ⁽²⁾	TPS383xE18		1.64	1.71	1.73	V	
		TPS383xJ25		2.16	2.25	2.31		
		TPS383xH30		2.7	2.79	2.85		
		TPS383xL30		2.54	2.64	2.71		
		TPS383xK33	$T_A = 25^\circ\text{C}$	2.82	2.93	3.1		
			$T_A = \text{Full range}$	2.72	2.93	3.2		
V_{hys}	Hysteresis at V_{DD} input		$1.7\text{ V} < V_{IT} < 2.5\text{ V}$		30		mV	
			$2.5\text{ V} < V_{IT} < 3.5\text{ V}$		40			
			$3.5\text{ V} < V_{IT} < 5\text{ V}$		50			
I_{IH}	High-level input current	\overline{MR} ⁽³⁾	$\overline{MR} = 0.7 \times V_{DD}, V_{DD} = 6\text{ V}$	$T_A = 25^\circ\text{C}$	-30	-60	-90	μA
				$T_A = \text{Full range}$	-20	-60	-120	
		CT	$CT = V_{DD} = 6\text{ V}$		-25		25	nA
I_{IL}	Low-level input current	\overline{MR} ⁽³⁾	$\overline{MR} = 0\text{ V}, V_{DD} = 6\text{ V}$	$T_A = 25^\circ\text{C}$	-130	-200	-340	μA
				$T_A = \text{Full range}$	-90	-200	-350	
		CT	$CT = 0\text{ V}, V_{DD} = 6\text{ V}$		-25		25	nA
I_{OH}	High-level output current	TPS3838	$V_{DD} = V_{IT} + 0.2\text{ V}, V_{OH} = V_{DD}$				25	nA

(1) The lowest voltage at which \overline{RESET} output becomes active, $t_r, V_{DD} \geq 15\text{ }\mu\text{s/V}$

(2) To ensure best stability of the threshold voltage, a bypass capacitor (ceramic, 0.1 μF) should be placed near the supply terminal.

(3) If manual reset is unused, \overline{MR} should be connected to V_{DD} to minimize current consumption.

Electrical Characteristics (continued)

over recommended operating conditions (unless otherwise noted)

PARAMETER		TEST CONDITIONS		MIN	TYP	MAX	UNIT
I_{DD}	Supply current	$V_{DD} > V_{IT}, V_{DD} < 3\text{ V}$	$T_A = 25^\circ\text{C}$		220	500	nA
			$T_A = \text{Full range}$			600	
		$V_{DD} > V_{IT}, V_{DD} > 3\text{ V}$	$T_A = 25^\circ\text{C}$		250	550	
			$T_A = \text{Full range}$			650	
		$V_{DD} < V_{IT}$	$T_A = 25^\circ\text{C}$		10	25	μA
			$T_A = \text{Full range}$			30	
Internal pullup resistor at \overline{MR}					33		kΩ
C_I	Input capacitance at \overline{MR} , CT	$V_I = 0\text{ V to } V_{DD}$			5		pF

Timing Requirements

 $R_L = 1\text{ M}\Omega$, $C_L = 50\text{ pF}$, $T_A = 25^\circ\text{C}$

PARAMETER		TEST CONDITIONS		TYP	UNIT
t_w	Pulse width	At V_{DD}	$V_{IH} = V_{IT} + 0.2\text{ V}$, $V_{IL} = V_{IT} - 0.2\text{ V}$	6	μs
		At \overline{MR}	$V_{DD} \geq V_{IT} + 0.2\text{ V}$, $V_{IL} = 0.3 \times V_{DD}$, $V_{IH} = 0.7 \times V_{DD}$	1	μs

Switching Characteristics

 $R_L = 1\text{ M}\Omega$, $C_L = 50\text{ pF}$, $T_A = 25^\circ\text{C}$

PARAMETER		TEST CONDITIONS		MIN	TYP	MAX	UNIT
t_d	Delay time	$V_{DD} \geq V_{IT} + 0.2\text{ V}$, $\overline{MR} = 0.7 \times V_{DD}$, See timing diagram	CT = GND	5	10	15	ms
			CT = V_{DD}		200		
t_{PHL}	Propagation (delay) time, high- to low-level output	V_{DD} to \overline{RESET} delay (TPS3836, TPS3838)	$V_{IL} = V_{IT} - 0.2\text{ V}$, $V_{IH} = V_{IT} + 0.2\text{ V}$		10		μs
			$V_{IL} = 1.6\text{ V}$		50		
t_{PLH}	Propagation (delay) time, low- to high-level output	V_{DD} to RESET delay (TPS3837)	$V_{IL} = V_{IT} - 0.2\text{ V}$, $V_{IH} = V_{IT} + 0.2\text{ V}$		10		μs
			$V_{IL} = 1.6\text{ V}$		50		
t_{PHL}	Propagation (delay) time, high- to low-level output	\overline{MR} to RESET delay (TPS3836, TPS3838)	$V_{DD} \geq V_{IT} + 0.2\text{ V}$, $V_{IL} = 0.3 \times V_{DD}$, $V_{IH} = 0.7 \times V_{DD}$		0.3		μs
t_{PLH}	Propagation (delay) time, low- to high-level output	\overline{MR} to RESET delay (TPS3837)	$V_{DD} \geq V_{IT} + 0.2\text{ V}$, $V_{IL} = 0.3 \times V_{DD}$, $V_{IH} = 0.7 \times V_{DD}$		0.3		μs

TYPICAL CHARACTERISTICS

Table of Graphs

			FIGURE
I_{DD}	Supply current	vs Supply voltage	2
I_{MR}	Manual reset current	vs Manual reset voltage	3
V_{OL}	Low-level output voltage	vs Low-level output current	4
V_{OH}	High-level output voltage	vs High-level output current	5
	Normalized reset threshold voltage	vs Free-air temperature	6
	Minimum pulse duration at V_{DD}	vs V_{DD} threshold overdrive	7

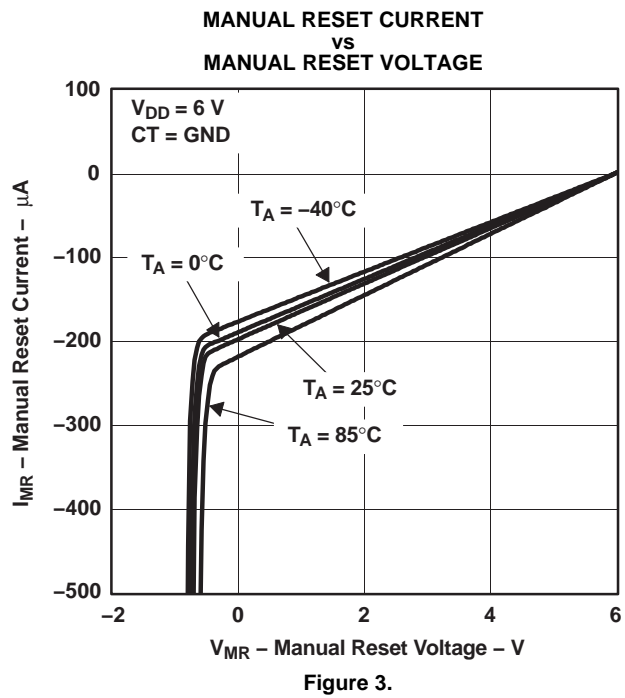
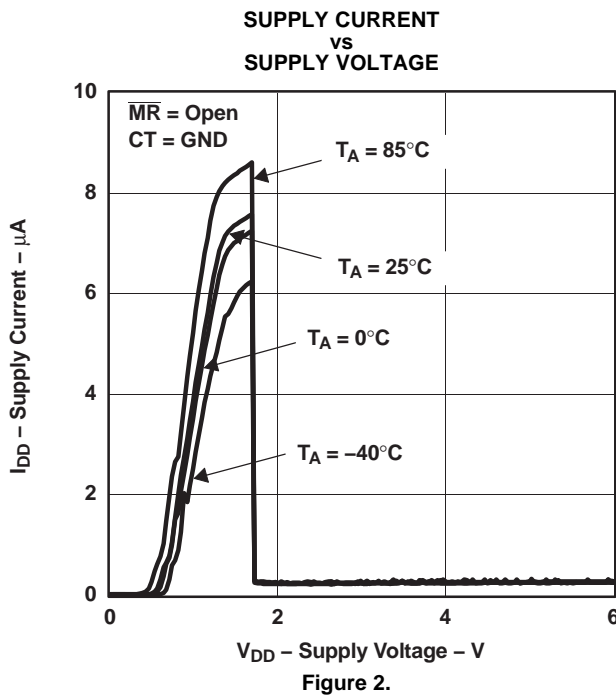

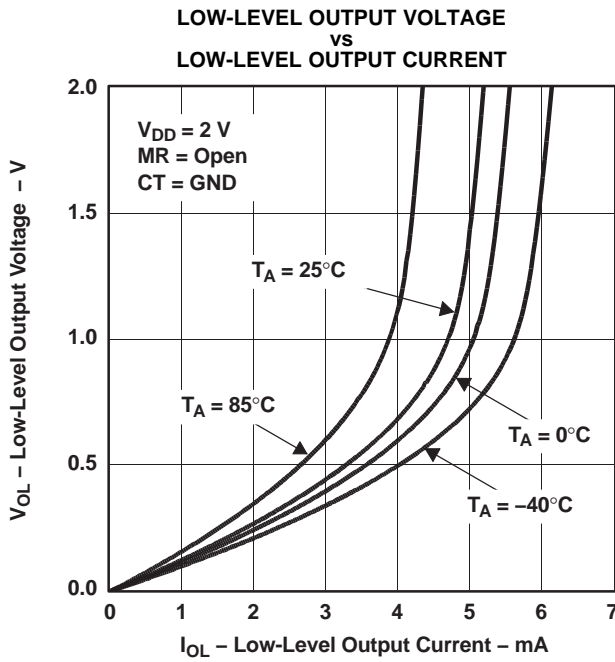

Figure 4.

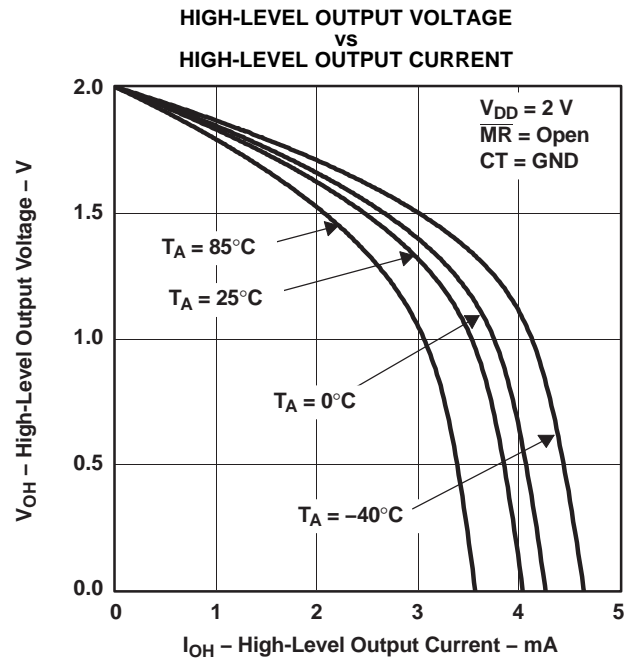

Figure 5.

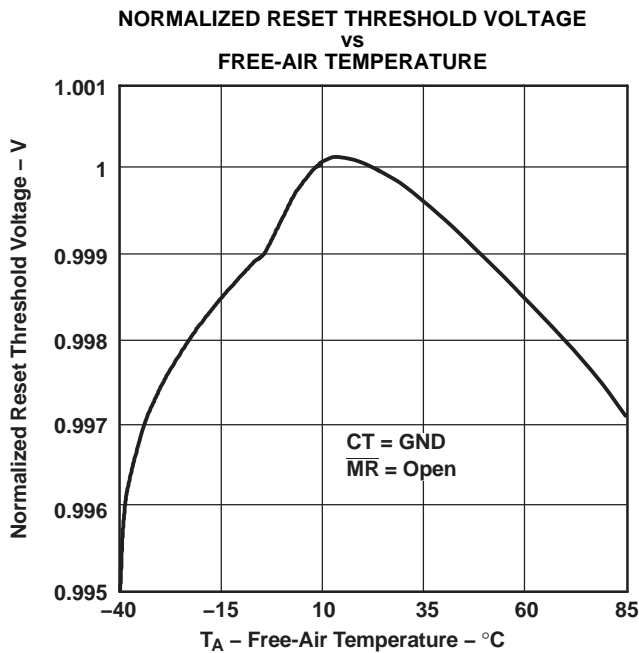

Figure 6.

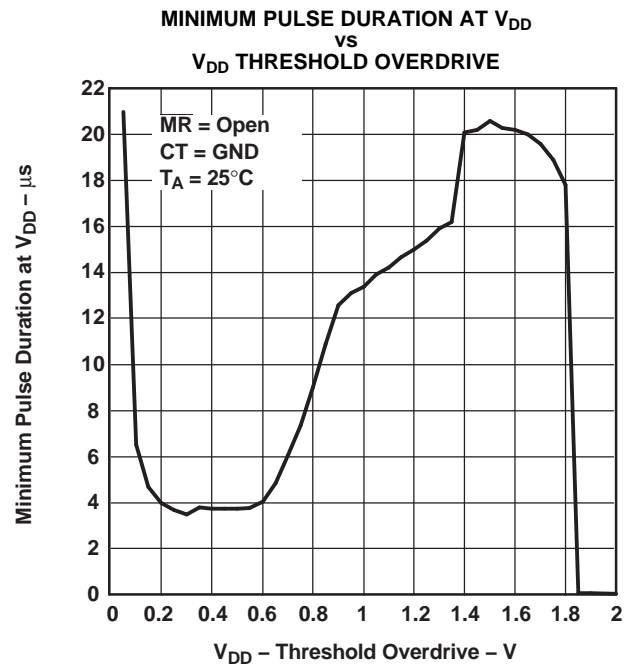

Figure 7.

PACKAGING INFORMATION

Orderable Device	Status (1)	Package Type	Package Drawing	Pins	Package Qty	Eco Plan (2)	Lead/Ball Finish (6)	MSL Peak Temp (3)	Op Temp (°C)	Device Marking (4/5)	Samples
TPS3836J25MDBVTEP	ACTIVE	SOT-23	DBV	5	250	Green (RoHS & no Sb/Br)	CU NIPDAU	Level-1-260C-UNLIM	-55 to 125	PKRM	Samples
TPS3836L30MDBVREP	ACTIVE	SOT-23	DBV	5	3000	Green (RoHS & no Sb/Br)	CU NIPDAU	Level-1-260C-UNLIM	-55 to 125	BTX	Samples
TPS3837K33MDBVREP	ACTIVE	SOT-23	DBV	5	3000	Green (RoHS & no Sb/Br)	CU NIPDAU	Level-1-260C-UNLIM	-55 to 125	PKZM	Samples
TPS3837K33QDBVREP	ACTIVE	SOT-23	DBV	5	3000	Green (RoHS & no Sb/Br)	CU NIPDAU	Level-1-260C-UNLIM	-40 to 125	PLSQ	Samples
V62/06637-09XE	ACTIVE	SOT-23	DBV	5	3000	Green (RoHS & no Sb/Br)	CU NIPDAU	Level-1-260C-UNLIM	-40 to 125	PLSQ	Samples
V62/06637-15XE	ACTIVE	SOT-23	DBV	5	250	Green (RoHS & no Sb/Br)	CU NIPDAU	Level-1-260C-UNLIM	-55 to 125	PKRM	Samples
V62/06637-17XE	ACTIVE	SOT-23	DBV	5	3000	Green (RoHS & no Sb/Br)	CU NIPDAU	Level-1-260C-UNLIM	-55 to 125	BTX	Samples
V62/06637-22XE	ACTIVE	SOT-23	DBV	5	3000	Green (RoHS & no Sb/Br)	CU NIPDAU	Level-1-260C-UNLIM	-55 to 125	PKZM	Samples

(1) The marketing status values are defined as follows:

ACTIVE: Product device recommended for new designs.

LIFEBUY: TI has announced that the device will be discontinued, and a lifetime-buy period is in effect.

NRND: Not recommended for new designs. Device is in production to support existing customers, but TI does not recommend using this part in a new design.

PREVIEW: Device has been announced but is not in production. Samples may or may not be available.

OBSOLETE: TI has discontinued the production of the device.

(2) Eco Plan - The planned eco-friendly classification: Pb-Free (RoHS), Pb-Free (RoHS Exempt), or Green (RoHS & no Sb/Br) - please check <http://www.ti.com/productcontent> for the latest availability information and additional product content details.

TBD: The Pb-Free/Green conversion plan has not been defined.

Pb-Free (RoHS): TI's terms "Lead-Free" or "Pb-Free" mean semiconductor products that are compatible with the current RoHS requirements for all 6 substances, including the requirement that lead not exceed 0.1% by weight in homogeneous materials. Where designed to be soldered at high temperatures, TI Pb-Free products are suitable for use in specified lead-free processes.

Pb-Free (RoHS Exempt): This component has a RoHS exemption for either 1) lead-based flip-chip solder bumps used between the die and package, or 2) lead-based die adhesive used between the die and leadframe. The component is otherwise considered Pb-Free (RoHS compatible) as defined above.

Green (RoHS & no Sb/Br): TI defines "Green" to mean Pb-Free (RoHS compatible), and free of Bromine (Br) and Antimony (Sb) based flame retardants (Br or Sb do not exceed 0.1% by weight in homogeneous material)

(3) MSL, Peak Temp. - The Moisture Sensitivity Level rating according to the JEDEC industry standard classifications, and peak solder temperature.

(4) There may be additional marking, which relates to the logo, the lot trace code information, or the environmental category on the device.

(5) Multiple Device Markings will be inside parentheses. Only one Device Marking contained in parentheses and separated by a "~" will appear on a device. If a line is indented then it is a continuation of the previous line and the two combined represent the entire Device Marking for that device.

(6) Lead/Ball Finish - Orderable Devices may have multiple material finish options. Finish options are separated by a vertical ruled line. Lead/Ball Finish values may wrap to two lines if the finish value exceeds the maximum column width.

Important Information and Disclaimer:The information provided on this page represents TI's knowledge and belief as of the date that it is provided. TI bases its knowledge and belief on information provided by third parties, and makes no representation or warranty as to the accuracy of such information. Efforts are underway to better integrate information from third parties. TI has taken and continues to take reasonable steps to provide representative and accurate information but may not have conducted destructive testing or chemical analysis on incoming materials and chemicals. TI and TI suppliers consider certain information to be proprietary, and thus CAS numbers and other limited information may not be available for release.

In no event shall TI's liability arising out of such information exceed the total purchase price of the TI part(s) at issue in this document sold by TI to Customer on an annual basis.

OTHER QUALIFIED VERSIONS OF TPS3836-EP, TPS3836J25-EP, TPS3837K33-EP :

- Catalog: [TPS3836](#), [TPS3836J25](#), [TPS3837K33](#)
- Automotive: [TPS3836-Q1](#), [TPS3836J25-Q1](#), [TPS3837K33-Q1](#)

NOTE: Qualified Version Definitions:

- Catalog - TI's standard catalog product
- Automotive - Q100 devices qualified for high-reliability automotive applications targeting zero defects

TAPE AND REEL INFORMATION



QUADRANT ASSIGNMENTS FOR PIN 1 ORIENTATION IN TAPE



*All dimensions are nominal

Device	Package Type	Package Drawing	Pins	SPQ	Reel Diameter (mm)	Reel Width W1 (mm)	A0 (mm)	B0 (mm)	K0 (mm)	P1 (mm)	W (mm)	Pin1 Quadrant
TPS3836J25MDBVTEP	SOT-23	DBV	5	250	180.0	9.0	3.15	3.2	1.4	4.0	8.0	Q3
TPS3836L30MDBVREP	SOT-23	DBV	5	3000	180.0	9.0	3.15	3.2	1.4	4.0	8.0	Q3
TPS3837K33MDBVREP	SOT-23	DBV	5	3000	180.0	9.0	3.15	3.2	1.4	4.0	8.0	Q3
TPS3837K33QDBVREP	SOT-23	DBV	5	3000	180.0	9.0	3.15	3.2	1.4	4.0	8.0	Q3

TAPE AND REEL BOX DIMENSIONS

*All dimensions are nominal

Device	Package Type	Package Drawing	Pins	SPQ	Length (mm)	Width (mm)	Height (mm)
TPS3836J25MDBVTEP	SOT-23	DBV	5	250	182.0	182.0	20.0
TPS3836L30MDBVREP	SOT-23	DBV	5	3000	182.0	182.0	20.0
TPS3837K33MDBVREP	SOT-23	DBV	5	3000	182.0	182.0	20.0
TPS3837K33QDBVREP	SOT-23	DBV	5	3000	182.0	182.0	20.0

DBV0005A



PACKAGE OUTLINE

SOT-23 - 1.45 mm max height

SMALL OUTLINE TRANSISTOR



4214839/D 11/2018

NOTES:

1. All linear dimensions are in millimeters. Any dimensions in parenthesis are for reference only. Dimensioning and tolerancing per ASME Y14.5M.
2. This drawing is subject to change without notice.
3. Reference JEDEC MO-178.
4. Body dimensions do not include mold flash, protrusions, or gate burrs. Mold flash, protrusions, or gate burrs shall not exceed 0.15 mm per side.

EXAMPLE BOARD LAYOUT

DBV0005A

SOT-23 - 1.45 mm max height

SMALL OUTLINE TRANSISTOR



LAND PATTERN EXAMPLE
EXPOSED METAL SHOWN
SCALE:15X



SOLDER MASK DETAILS

4214839/D 11/2018

NOTES: (continued)

- 5. Publication IPC-7351 may have alternate designs.
- 6. Solder mask tolerances between and around signal pads can vary based on board fabrication site.

EXAMPLE STENCIL DESIGN

DBV0005A

SOT-23 - 1.45 mm max height

SMALL OUTLINE TRANSISTOR



SOLDER PASTE EXAMPLE
BASED ON 0.125 mm THICK STENCIL
SCALE:15X

4214839/D 11/2018

NOTES: (continued)

7. Laser cutting apertures with trapezoidal walls and rounded corners may offer better paste release. IPC-7525 may have alternate design recommendations.
8. Board assembly site may have different recommendations for stencil design.

IMPORTANT NOTICE AND DISCLAIMER

TI PROVIDES TECHNICAL AND RELIABILITY DATA (INCLUDING DATASHEETS), DESIGN RESOURCES (INCLUDING REFERENCE DESIGNS), APPLICATION OR OTHER DESIGN ADVICE, WEB TOOLS, SAFETY INFORMATION, AND OTHER RESOURCES "AS IS" AND WITH ALL FAULTS, AND DISCLAIMS ALL WARRANTIES, EXPRESS AND IMPLIED, INCLUDING WITHOUT LIMITATION ANY IMPLIED WARRANTIES OF MERCHANTABILITY, FITNESS FOR A PARTICULAR PURPOSE OR NON-INFRINGEMENT OF THIRD PARTY INTELLECTUAL PROPERTY RIGHTS.

These resources are intended for skilled developers designing with TI products. You are solely responsible for (1) selecting the appropriate TI products for your application, (2) designing, validating and testing your application, and (3) ensuring your application meets applicable standards, and any other safety, security, or other requirements. These resources are subject to change without notice. TI grants you permission to use these resources only for development of an application that uses the TI products described in the resource. Other reproduction and display of these resources is prohibited. No license is granted to any other TI intellectual property right or to any third party intellectual property right. TI disclaims responsibility for, and you will fully indemnify TI and its representatives against, any claims, damages, costs, losses, and liabilities arising out of your use of these resources.

TI's products are provided subject to TI's Terms of Sale (www.ti.com/legal/termsofsale.html) or other applicable terms available either on ti.com or provided in conjunction with such TI products. TI's provision of these resources does not expand or otherwise alter TI's applicable warranties or warranty disclaimers for TI products.

Mailing Address: Texas Instruments, Post Office Box 655303, Dallas, Texas 75265
Copyright © 2019, Texas Instruments Incorporated

Looking for pricing, stock, or lifecycle information?

Click below to explore more details on WIN SOURCE:

 [View TPS3836J25MDBVTEP](#) on WIN SOURCE

 [Texas Instruments](#) Information

Optimize Your Supply Chain with WIN SOURCE Solutions

-  Global Sourcing Solution
-  Obsolete Management
-  Cost Control Management
-  Shortage Management
-  Alternative Solution
-  Excess Inventory Management