



**THE DATASHEET OF
DG441BDJ-E3**



Improved Quad SPST CMOS Analog Switches

DESCRIPTION

The DG441B, DG442B are monolithic quad analog switches designed to provide high speed, low error switching of analog and audio signals. The DG441B, DG442B are upgrades to the original DG441, DG442.

Combining low on-resistance (45Ω , typ.) with high speed (t_{ON} 120 ns, typ.), the DG441B, DG442B are ideally suited for Data Acquisition, Communication Systems, Automatic Test Equipment, or Medical Instrumentation. Charge injection has been minimized on the drain for use in sample-and-hold circuits.

The DG441B, DG442B are built using Vishay Siliconix's high-voltage silicon-gate process. An epitaxial layer prevents latchup.

When on, each switch conducts equally well in both directions and blocks input voltages to the supply levels when off.

FEATURES

- Low On-Resistance: 45Ω
- Low Power Consumption: 1 mW
- Fast Switching Action - t_{ON} : 120 ns
- Low Charge Injection - Q: - 1 pC
- TTL/CMOS-Compatible Logic
- Single Supply Capability
- Material categorization: For definitions of compliance please see www.vishay.com/doc?99912



RoHS
COMPLIANT
HALOGEN
FREE

BENEFITS

- Less Signal Errors and Distortion
- Reduced Power Supply Requirements
- Faster Throughput
- Reduced Pedestal Errors
- Simple Interfacing

APPLICATIONS

- Audio Switching
- Data Acquisition
- Sample-and-Hold Circuits
- Communication Systems
- Automatic Test Equipment
- Medical Instruments

FUNCTIONAL BLOCK DIAGRAM AND PIN CONFIGURATION

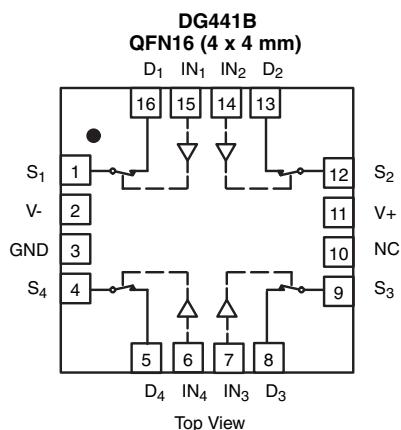
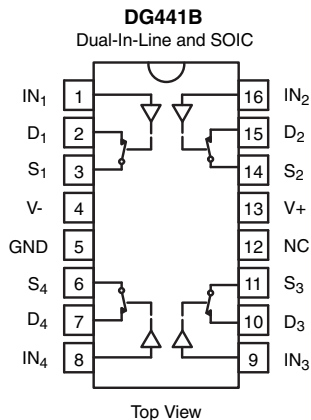

TRUTH TABLE		
Logic	DG441B	DG442B
0	ON	OFF
1	OFF	ON

Logic "0" ≤ 0.8 V

Logic "1" ≥ 2.4 V

ORDERING INFORMATION		
Temp Range	Package	Part Number
- 40 °C to 85 °C	16-pin Plastic DIP	DG441BDJ
		DG441BDJ-E3
		DG442BDJ
	16-pin Narrow SOIC	DG442BDJ-E3
		DG441BDY-E3
		DG441BDY-T1-E3
		DG442BDY-E3
	16 pin QFN 4 x 4 mm (Variation 1)	DG442BDY-T1-E3
		DG441BDN-T1-E4

ABSOLUTE MAXIMUM RATINGS ($T_A = 25\text{ }^\circ\text{C}$, unless otherwise noted)			
Parameter	Symbol	Limit	Unit
V+ to V-		44	V
GND to V-		25	
Digital Inputs ^a , V_S , V_D		(V-) - 2 to (V+) + 2 or 30 mA, whichever occurs first	
Continuous Current (Any Terminal)		30	mA
Current, S or D (Pulsed at 1 ms, 10 % duty cycle)		100	
Storage Temperature		- 65 to 125	$^\circ\text{C}$
Power Dissipation (Package) ^b	16-pin Plastic DIP ^c	470	mW
	16-pin Narrow Body SOIC ^d	900	
	QFN-16 ^d	850	

Notes:

- Signals on S_X , D_X , or IN_X exceeding V+ or V- will be clamped by internal diodes. Limit forward diode current to maximum current ratings.
- All leads welded or soldered to PC Board.
- Derate 6 mW/ $^\circ\text{C}$ above 75 $^\circ\text{C}$.
- Derate 12 mW/ $^\circ\text{C}$ above 75 $^\circ\text{C}$.



SPECIFICATIONS ^a (for dual supplies)							
Parameter	Symbol	Test Conditions Unless Otherwise Specified V ₊ = 15 V, V ₋ = - 15 V V _L = 5 V, V _{IN} = 2.4 V, 0.8 V ^e	Temp. ^b	Limits - 40 °C to 85 °C			Unit
				Min. ^d	Typ. ^c	Max. ^d	
Analog Switch							
Analog Signal Range ^e	V _{ANALOG}		Full	- 15		15	V
Drain-Source On-Resistance	R _{DS(on)}	I _S = 1 mA, V _D = ± 10 V	Room Full		45	80 95	Ω
On-Resistance Match Between Channels ^e	ΔR _{DS(on)}	I _S = 1 mA, V _D = ± 10 V	Room Full		2	4 5	
Switch Off Leakage Current	I _{S(off)}	V _D = ± 14 V, V _S = ± 14 V	Room Full	- 0.5 - 5	± 0.01	0.5 5	nA
	I _{D(off)}		Room Full	- 0.5 - 5	± 0.01	0.5 5	
Channel On Leakage Current	I _{D(on)}	V _S = V _D = ± 14 V	Room Full	- 0.5 - 10	± 0.02	0.5 10	
Digital Control							
Input Voltage Low	V _{INL}		Full			0.8	V
Input Voltage High	V _{INH}		Full	2.4			
Input Current V _{IN} Low	I _{INL}	V _{IN} under test = 0.8 V All Other = 2.4 V	Full	- 1	- 0.01	1	μA
Input Current V _{IN} High	I _{INH}	V _{IN} under test = 2.4 V All Other = 0.8 V	Full	- 1	0.01	1	
Dynamic Characteristics							
Turn-On Time	t _{ON}	R _L = 1 kΩ, C _L = 35 pF V _S = 10 V, See Figure 2	Room			120	ns
Turn-Off Time	t _{OFF}		Room			65	
Charge Injection ^e	Q	C _L = 1 nF, V _S = 0 V V _{gen} = 0 V, R _{gen} = 0 Ω	Room		- 1		pC
Off Isolation ^e	OIRR	R _L = 50 Ω, C _L = 15 pF V _S = 1 V _{RMS} , f = 100 kHz	Room			- 90	dB
Crosstalk (Channel-to-Channel)	X _{TALK}		Room			- 95	
Source Off Capacitance ^e	C _{S(off)}	f = 1 MHz	Room			4	pF
Drain Off Capacitance ^e	C _{D(off)}		Room			4	
Channel On Capacitance ^e	C _{D(on)}	V _S = V _D = 0 V, f = 1 MHz	Room			16	
Power Supplies							
Positive Supply Current	I ₊	V ₊ = 16.5 V, V ₋ = - 16.5 V V _{IN} = 0 or 5 V	Room Full			1 5	μA
Negative Supply Current	I ₋		Room Full	- 1 - 5			

SPECIFICATIONS (for single supply)							
Parameter	Symbol	Test Conditions Unless Otherwise Specified $V_+ = 12\text{ V}$, $V_- = 0\text{ V}$ $V_{IN} = 2.4\text{ V}$, 0.8 V^e	Temp. ^b	Limits - 40 °C to 85 °C			Unit
				Min. ^d	Typ. ^c	Max. ^d	
Analog Switch							
Analog Signal Range ^e	V_{ANALOG}		Full	0		12	V
Drain-Source On-Resistance	$R_{DS(on)}$	$I_S = 1\text{ mA}$, $V_D = 3\text{ V}$, 8 V	Room Full		90	160 200	Ω
Dynamic Characteristics							
Turn-On Time	t_{ON}	$R_L = 1\text{ k}\Omega$, $C_L = 35\text{ pF}$, $V_S = 8\text{ V}$	Room		120	300	ns
Turn-Off Time	t_{OFF}	See Figure 2	Room		60	200	
Charge Injection	Q	$C_L = 1\text{ nF}$, $V_{gen} = 6\text{ V}$, $R_{gen} = 0\text{ }\Omega$	Room		4		pC
Power Supplies							
Positive Supply Current	I_+	$V_{IN} = 0\text{ V}$ or 5 V	Room Full			1 5	μA
Negative Supply Current	I_-		Room Full	- 1 - 5			

Notes:

- a. Refer to PROCESS OPTION FLOWCHART.
- b. Room = 25 °C, Full = as determined by the operating temperature suffix.
- c. Typical values are for DESIGN AID ONLY, not guaranteed nor subject to production testing.
- d. The algebraic convention whereby the most negative value is a minimum and the most positive a maximum, is used in this data sheet.
- e. Guaranteed by design, not subject to production test.
- f. V_{IN} = input voltage to perform proper function.

Stresses beyond those listed under "Absolute Maximum Ratings" may cause permanent damage to the device. These are stress ratings only, and functional operation of the device at these or any other conditions beyond those indicated in the operational sections of the specifications is not implied. Exposure to absolute maximum rating conditions for extended periods may affect device reliability.

SCHEMATIC DIAGRAM (typical channel)

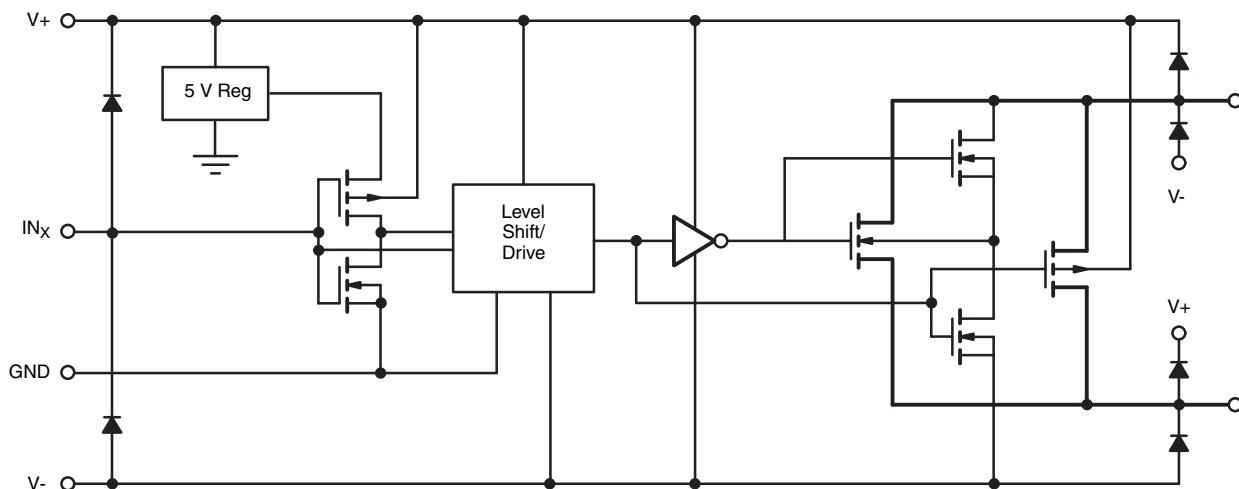
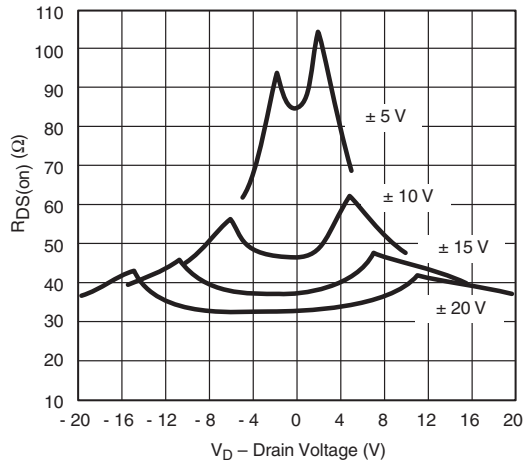
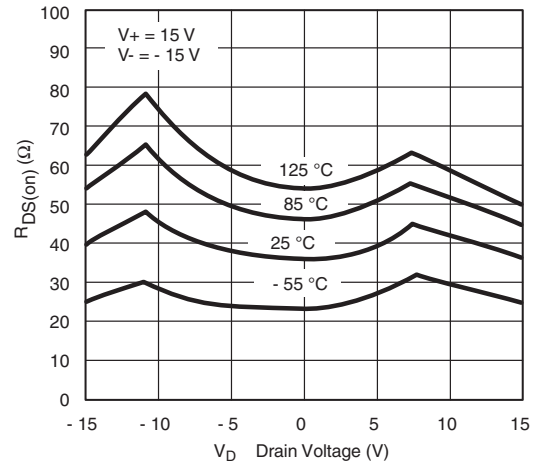

Figure 1.

TYPICAL CHARACTERISTICS (T_A = 25 °C, unless otherwise noted)



R_{DS(on)} vs. V_D and Power Supply Voltages



R_{DS(on)} vs. V_D and Temperature

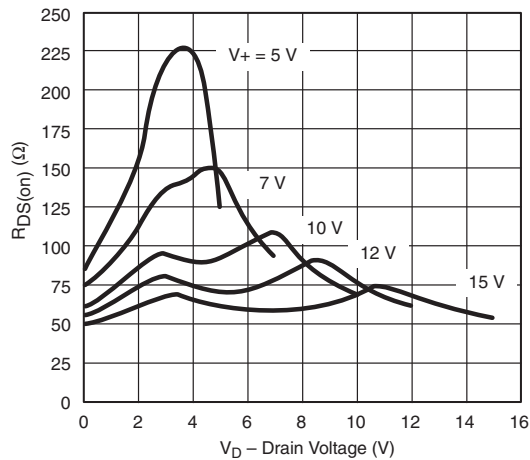

R_{DS(on)} vs. V_D and Single Power Supply Voltages

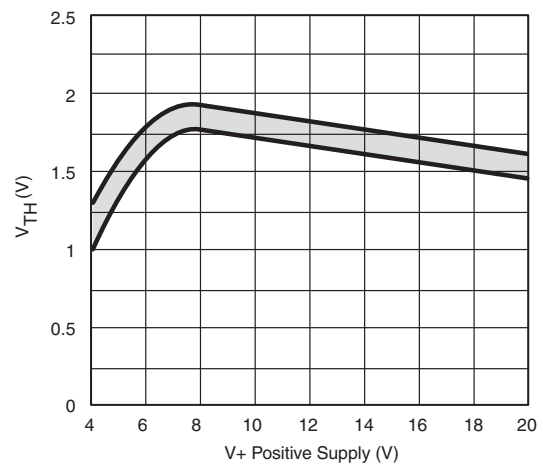

Input Switching Threshold vs. Supply Voltage

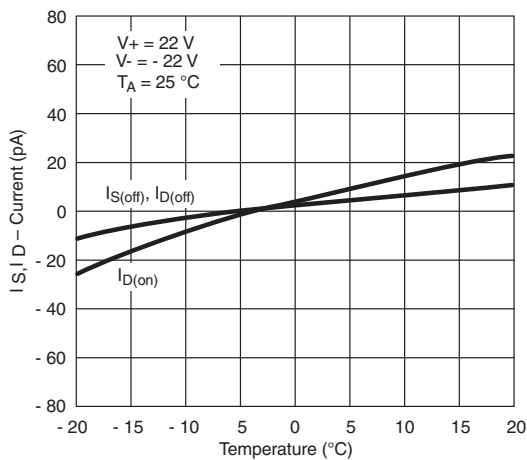

Leakage Currents vs. Analog Voltage

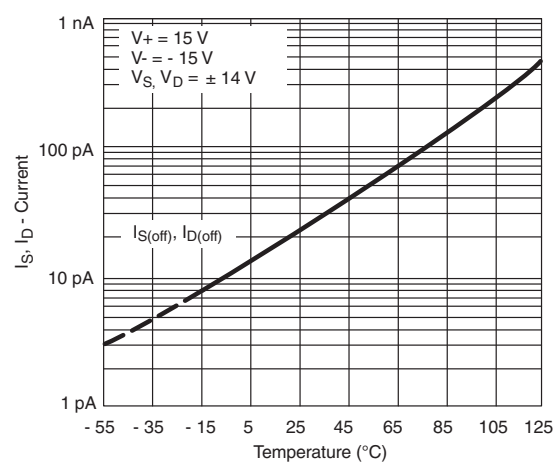

Leakage Currents vs. Temperature

TYPICAL CHARACTERISTICS ($T_A = 25\text{ }^\circ\text{C}$, unless otherwise noted)

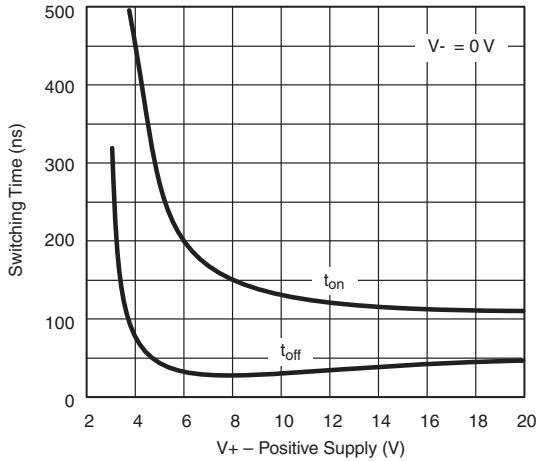

Switching Time vs. Single Supply Voltage

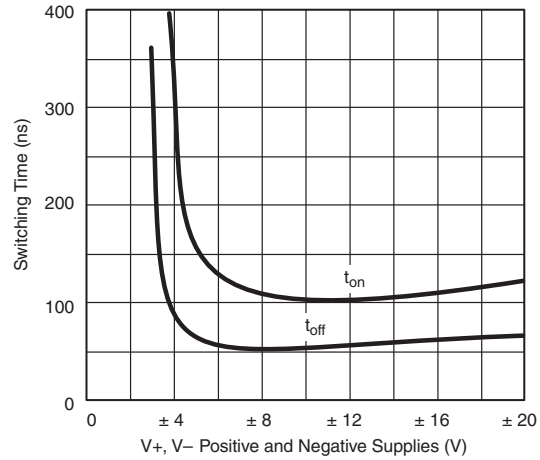

Switching Times vs. Power Supply Voltage

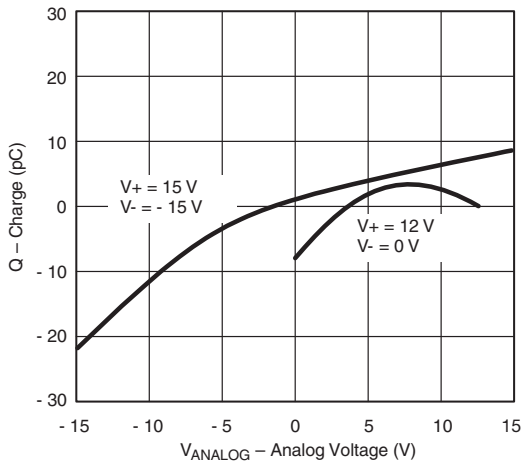

Q_S, Q_D - Charge Injection vs. Analog Voltage

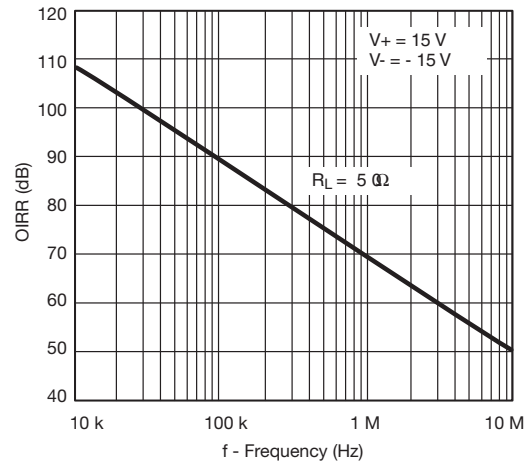

Off Isolation vs. Frequency

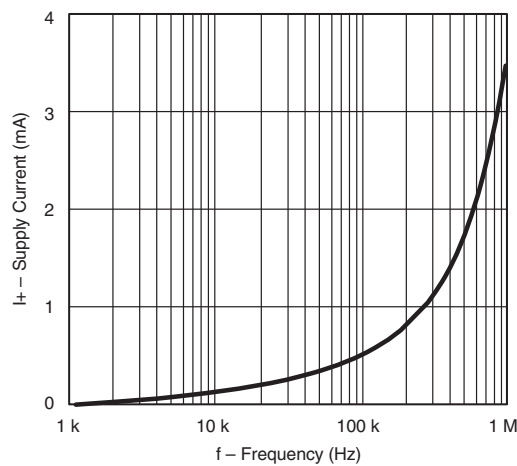

Supply Current vs. Switching Frequency

TEST CIRCUITS

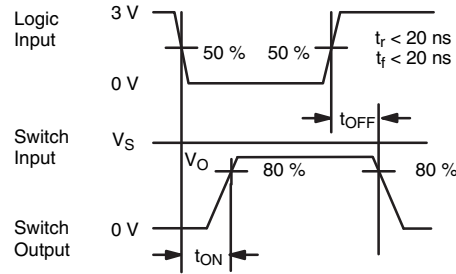
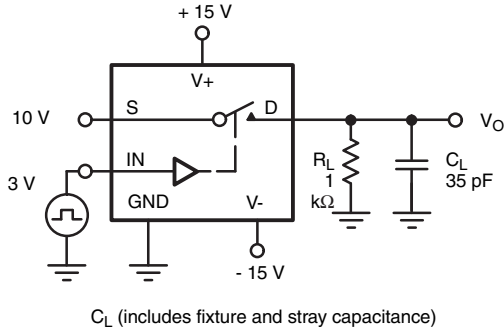

Note: Logic input waveform is inverted for DG442.

Figure 2. Switching Time

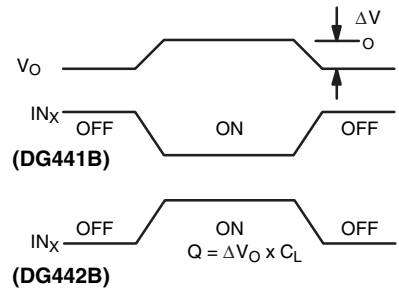
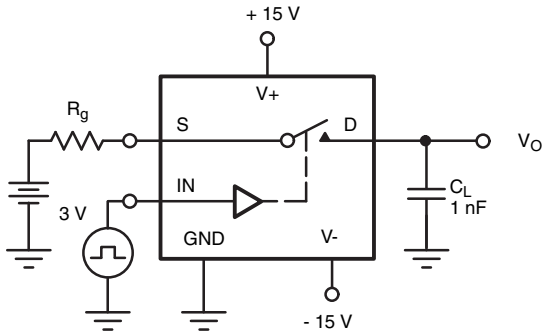

Figure 3. Charge Injection

$C = 1 \text{ mF}$ tantalum in parallel with 0.01 mF ceramic

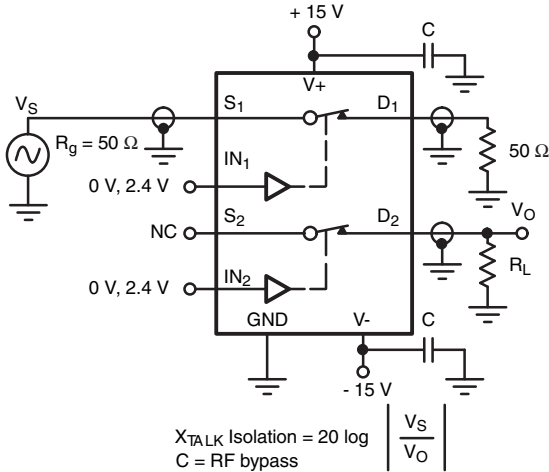

Figure 4. Crosstalk

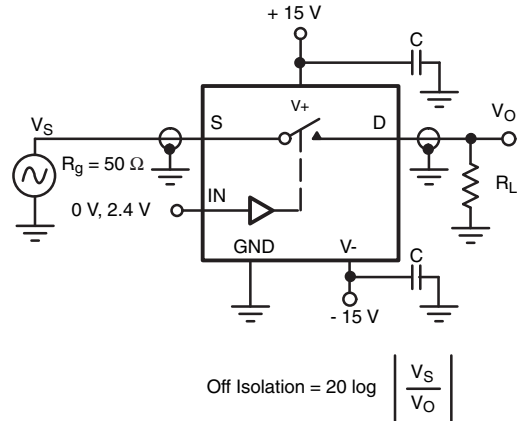

Figure 5. Off Isolation

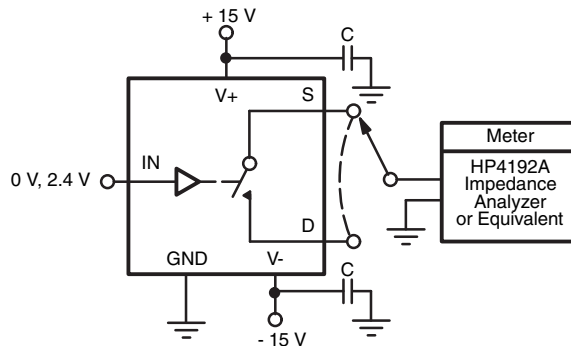

Figure 6. Source/Drain Capacitances

APPLICATIONS

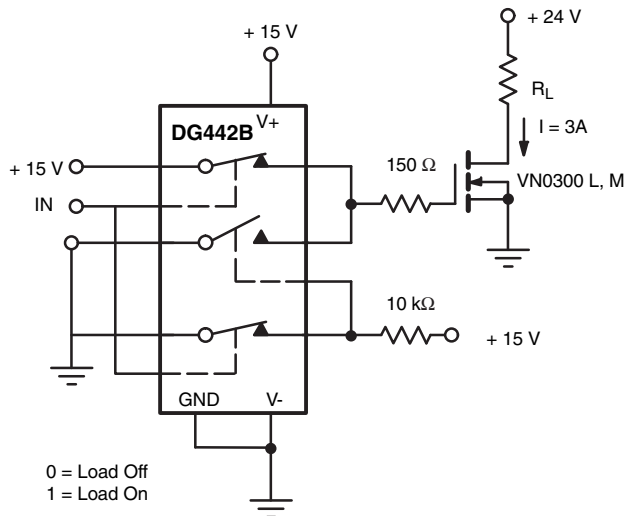

Figure 7. Power MOSFET Driver

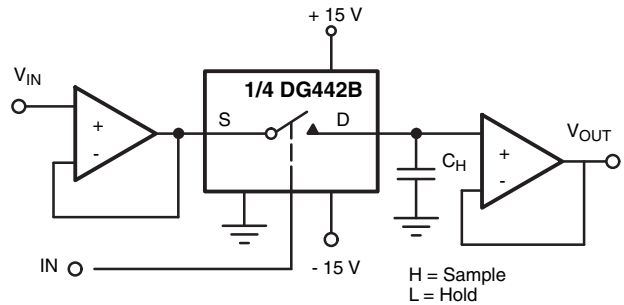
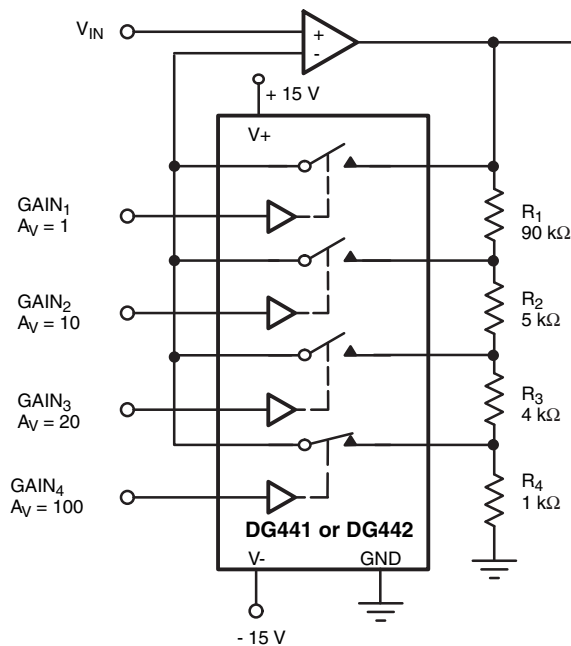

Figure 8. Open Loop Sample-and-Hold



Gain error is determined only by the resistor tolerance. Op amp offset and CMRR will limit accuracy of circuit.

With SW₄ Closed

$$\frac{V_{OUT}}{V_{IN}} = \frac{R_1 + R_2 + R_3 + R_4}{R_4} = 100$$

Figure 9. Precision-Weighted Resistor Programmable-Gain Amplifier

Vishay Siliconix maintains worldwide manufacturing capability. Products may be manufactured at one of several qualified locations. Reliability data for Silicon Technology and Package Reliability represent a composite of all qualified locations. For related documents such as package/tape drawings, part marking, and reliability data, see www.vishay.com/ppg?72625.



SOIC (NARROW): 16-LEAD
JEDEC Part Number: MS-012



Dim	MILLIMETERS		INCHES	
	Min	Max	Min	Max
A	1.35	1.75	0.053	0.069
A ₁	0.10	0.20	0.004	0.008
B	0.38	0.51	0.015	0.020
C	0.18	0.23	0.007	0.009
D	9.80	10.00	0.385	0.393
E	3.80	4.00	0.149	0.157
e	1.27 BSC		0.050 BSC	
H	5.80	6.20	0.228	0.244
L	0.50	0.93	0.020	0.037
∅	0°	8°	0°	8°

ECN: S-03946—Rev. F, 09-Jul-01
DWG: 5300

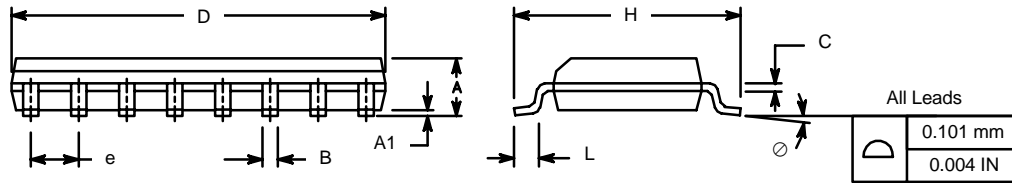

PDIP: 16-LEAD



Dim	MILLIMETERS		INCHES	
	Min	Max	Min	Max
A	3.81	5.08	0.150	0.200
A₁	0.38	1.27	0.015	0.050
B	0.38	0.51	0.015	0.020
B₁	0.89	1.65	0.035	0.065
C	0.20	0.30	0.008	0.012
D	18.93	21.33	0.745	0.840
E	7.62	8.26	0.300	0.325
E₁	5.59	7.11	0.220	0.280
e₁	2.29	2.79	0.090	0.110
e_A	7.37	7.87	0.290	0.310
L	2.79	3.81	0.110	0.150
Q₁	1.27	2.03	0.050	0.080
S	0.38	1.52	.015	0.060

ECN: S-03946—Rev. D, 09-Jul-01
DWG: 5482

QFN 4x4-16L Case Outline

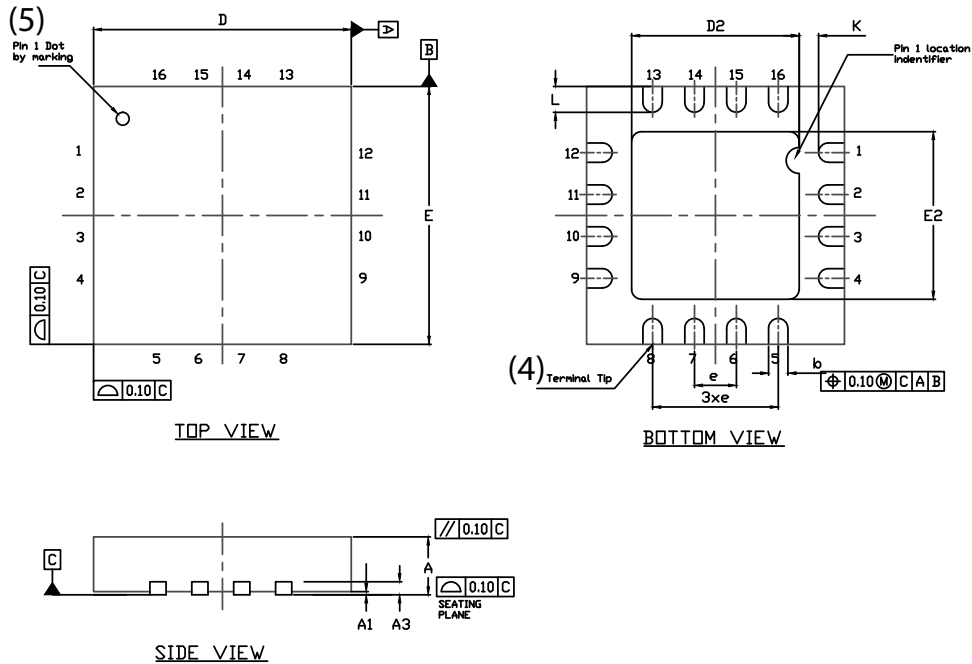

DIM	VARIATION 1						VARIATION 2					
	MILLIMETERS ⁽¹⁾			INCHES			MILLIMETERS ⁽¹⁾			INCHES		
	MIN.	NOM.	MAX.	MIN.	NOM.	MAX.	MIN.	NOM.	MAX.	MIN.	NOM.	MAX.
A	0.75	0.85	0.95	0.029	0.033	0.037	0.75	0.85	0.95	0.029	0.033	0.037
A1	0	-	0.05	0	-	0.002	0	-	0.05	0	-	0.002
A3	0.20 ref.			0.008 ref.			0.20 ref.			0.008 ref.		
b	0.25	0.30	0.35	0.010	0.012	0.014	0.25	0.30	0.35	0.010	0.012	0.014
D	4.00 BSC			0.157 BSC			4.00 BSC			0.157 BSC		
D2	2.0	2.1	2.2	0.079	0.083	0.087	2.5	2.6	2.7	0.098	0.102	0.106
e	0.65 BSC			0.026 BSC			0.65 BSC			0.026 BSC		
E	4.00 BSC			0.157 BSC			4.00 BSC			0.157 BSC		
E2	2.0	2.1	2.2	0.079	0.083	0.087	2.5	2.6	2.7	0.098	0.102	0.106
K	0.20 min.			0.008 min.			0.20 min.			0.008 min.		
L	0.5	0.6	0.7	0.020	0.024	0.028	0.3	0.4	0.5	0.012	0.016	0.020
N ⁽³⁾	16			16			16			16		
Nd ⁽³⁾	4			4			4			4		
Ne ⁽³⁾	4			4			4			4		

Notes

- (1) Use millimeters as the primary measurement.
- (2) Dimensioning and tolerances conform to ASME Y14.5M. - 1994.
- (3) N is the number of terminals. Nd and Ne is the number of terminals in each D and E site respectively.
- (4) Dimensions b applies to plated terminal and is measured between 0.15 mm and 0.30 mm from terminal tip.
- (5) The pin 1 identifier must be existed on the top surface of the package by using identification mark or other feature of package body.
- (6) Package warpage max. 0.05 mm.

ECN: S13-0893-Rev. B, 22-Apr-13
 DWG: 5890

RECOMMENDED MINIMUM PADS FOR SO-16

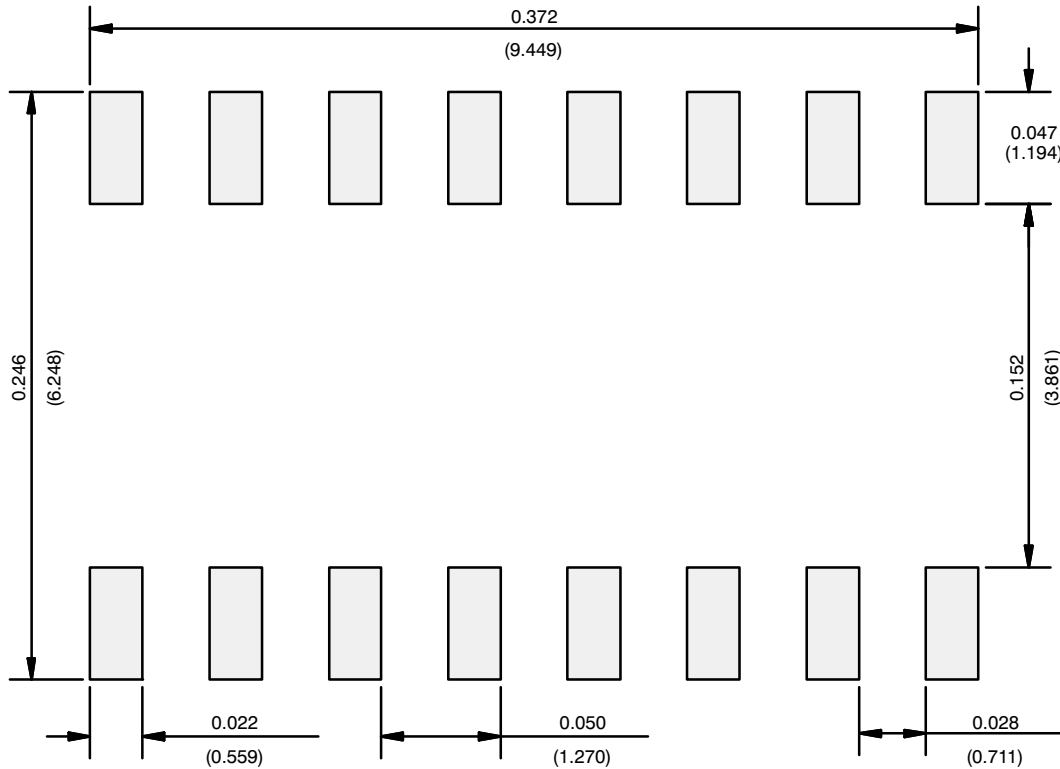

Recommended Minimum Pads
Dimensions in Inches/(mm)

[Return to Index](#)



Disclaimer

ALL PRODUCT, PRODUCT SPECIFICATIONS AND DATA ARE SUBJECT TO CHANGE WITHOUT NOTICE TO IMPROVE RELIABILITY, FUNCTION OR DESIGN OR OTHERWISE.

Vishay Intertechnology, Inc., its affiliates, agents, and employees, and all persons acting on its or their behalf (collectively, "Vishay"), disclaim any and all liability for any errors, inaccuracies or incompleteness contained in any datasheet or in any other disclosure relating to any product.

Vishay makes no warranty, representation or guarantee regarding the suitability of the products for any particular purpose or the continuing production of any product. To the maximum extent permitted by applicable law, Vishay disclaims (i) any and all liability arising out of the application or use of any product, (ii) any and all liability, including without limitation special, consequential or incidental damages, and (iii) any and all implied warranties, including warranties of fitness for particular purpose, non-infringement and merchantability.

Statements regarding the suitability of products for certain types of applications are based on Vishay's knowledge of typical requirements that are often placed on Vishay products in generic applications. Such statements are not binding statements about the suitability of products for a particular application. It is the customer's responsibility to validate that a particular product with the properties described in the product specification is suitable for use in a particular application. Parameters provided in datasheets and / or specifications may vary in different applications and performance may vary over time. All operating parameters, including typical parameters, must be validated for each customer application by the customer's technical experts. Product specifications do not expand or otherwise modify Vishay's terms and conditions of purchase, including but not limited to the warranty expressed therein.

Except as expressly indicated in writing, Vishay products are not designed for use in medical, life-saving, or life-sustaining applications or for any other application in which the failure of the Vishay product could result in personal injury or death. Customers using or selling Vishay products not expressly indicated for use in such applications do so at their own risk. Please contact authorized Vishay personnel to obtain written terms and conditions regarding products designed for such applications.

No license, express or implied, by estoppel or otherwise, to any intellectual property rights is granted by this document or by any conduct of Vishay. Product names and markings noted herein may be trademarks of their respective owners.

Looking for pricing, stock, or lifecycle information?

Click below to explore more details on WIN SOURCE:

 [View DG441BDJ-E3 on WIN SOURCE](#)

 [Vishay Information](#)

Optimize Your Supply Chain with WIN SOURCE Solutions

-  Global Sourcing Solution
-  Obsolete Management
-  Cost Control Management
-  Shortage Management
-  Alternative Solution
-  Excess Inventory Management