



**THE DATASHEET OF
LM2590HVS-3.3/NOPB**



LM2590HV SIMPLE SWITCHER® Power Converter 150-kHz, 1-A Step-Down Voltage Regulator

1 Features

- 3.3-V, 5-V, and Adjustable Output Versions
- Adjustable Version Output Voltage Range, 1.2 V to 57 V $\pm 4\%$ Max Over Line and Load Conditions
- Ensured 1-A Output Load Current
- Available in 7-Pin TO-220 and TO-263 (Surface-Mount) Package
- Input Voltage Range Up To 60 V
- 150-kHz Fixed Frequency Internal Oscillator
- Shutdown and Soft-start
- Out Of Regulation Error Flag
- Error Flag Delay
- Low Power Standby Mode, I_Q : 90 μ A (Typical)
- High Efficiency
- Thermal Shutdown And Current Limit Protection

2 Applications

- Simple High-Efficiency Step-Down (Buck) Regulators
- Efficient Preregulator For Linear Regulators
- On-Card Switching Regulators
- Positive-To-Negative Converters

3 Description

The LM2590HV series of regulators are monolithic integrated circuits that provide all the active functions for a step-down (buck) switching regulator, capable of driving a 1-A load with excellent line and load regulation. These devices are available in fixed output voltages of 3.3-V, 5-V, and an adjustable output version.

This series of switching regulators is similar to the LM2591HV with additional supervisory and control features.

Requiring a minimum number of external components, these regulators are simple to use and include internal frequency compensation, improved line and load specifications, fixed-frequency oscillator, Shutdown/Soft-start, output error flag and flag delay.

The LM2590HV operates at a switching frequency of 150 kHz thus allowing smaller sized filter components than what would be needed with lower frequency switching regulators. Available in a standard 7-pin TO-220 package with several different lead bend options, and a 7-pin TO-263 surface-mount package.

Other features include an ensured $\pm 4\%$ tolerance on output voltage under all conditions of input voltage and output load conditions, and $\pm 15\%$ on the oscillator frequency. External shutdown is included, featuring 90- μ A standby current (typical). Self protection features include a two stage current limit for the output switch and an over temperature shutdown for complete protection under fault conditions.

Device Information⁽¹⁾

PART NUMBER	PACKAGE	BODY SIZE (NOM)
LM2590HV	TO-220 (7)	14.99 mm \times 10.16 mm
	TO-263 (7)	10.10 mm \times 8.89 mm

(1) For all available packages, see the orderable addendum at the end of the data sheet.

Typical Application (Fixed Output Voltage Versions)

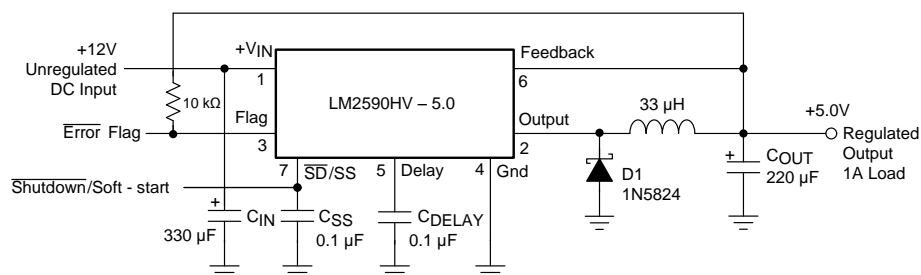

Copyright © 2016, Texas Instruments Incorporated



Table of Contents

1 Features	1	8.2 Functional Block Diagram	15
2 Applications	1	8.3 Feature Description	15
3 Description	1	8.4 Device Functional Modes	18
4 Revision History	2	9 Application and Implementation	19
5 Pin Configuration and Functions	3	9.1 Application Information	19
6 Specifications	5	9.2 Typical Application	21
6.1 Absolute Maximum Ratings	5	10 Power Supply Recommendations	25
6.2 ESD Ratings	5	11 Layout	25
6.3 Recommended Operating Conditions	5	11.1 Layout Guidelines	25
6.4 Thermal Information	5	11.2 Layout Examples	25
6.5 Electrical Characteristics	6	11.3 Thermal Considerations	26
6.6 Electrical Characteristics – 3.3-V Version	7	12 Device and Documentation Support	28
6.7 Electrical Characteristics – 5-V Version	7	12.1 Documentation Support	28
6.8 Electrical Characteristics – Adjustable Version	7	12.2 Receiving Notification of Documentation Updates	28
6.9 Typical Characteristics	9	12.3 Community Resources	28
7 Parameter Measurement Information	13	12.4 Trademarks	28
7.1 Test Circuits	13	12.5 Electrostatic Discharge Caution	28
8 Detailed Description	15	12.6 Glossary	28
8.1 Overview	15	13 Mechanical, Packaging, and Orderable Information	28

4 Revision History

Changes from Revision B (December 2001) to Revision C

Page

- Added *ESD Ratings* table, *Feature Description* section, *Device Functional Modes*, *Application and Implementation* section, *Power Supply Recommendations* section, *Layout* section, *Device and Documentation Support* section, and *Mechanical, Packaging, and Orderable Information* section **1**

5 Pin Configuration and Functions

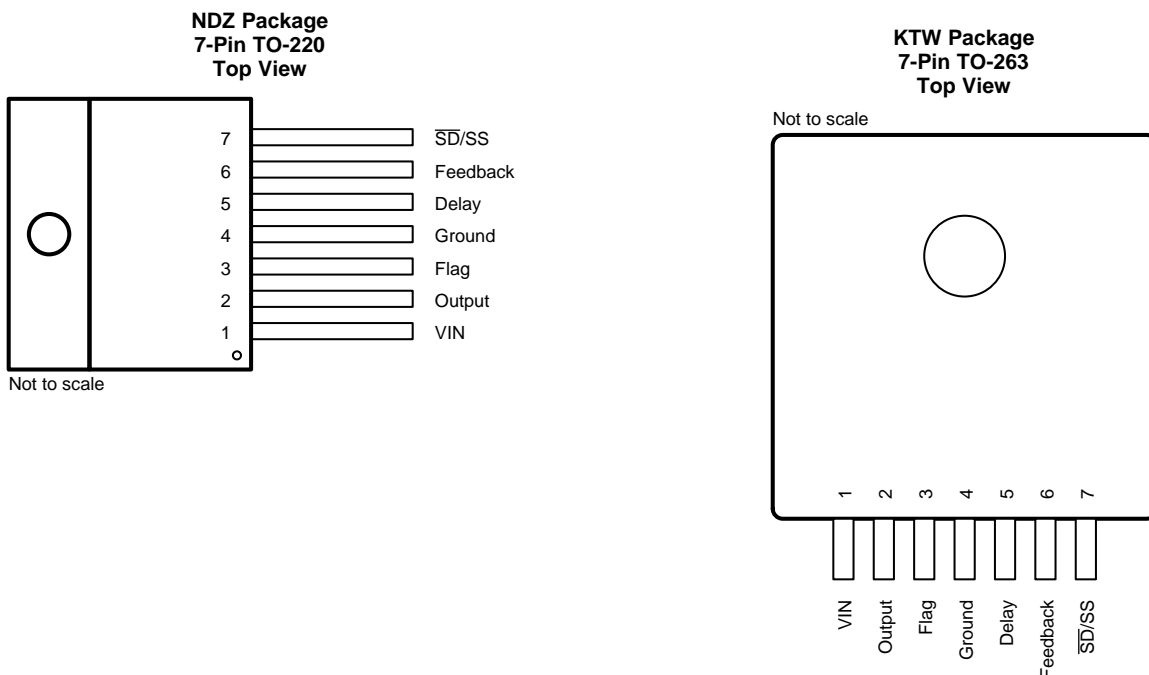

Pin Functions

PIN		TYPE ⁽¹⁾	DESCRIPTION
NO.	NAME		
1	V _{IN}	I	This is the positive input supply for the IC switching regulator. A suitable input bypass capacitor must be present at this pin to minimize voltage transients and to supply the switching currents needed by the regulator.
2	Output	O	Internal switch. The voltage at this pin switches between approximately (+V _{IN} – V _{SAT}) and approximately –0.5 V, with a duty cycle of V _{OUT} /V _{IN} .
3	Flag	O	Open collector output that goes active low (≤ 1 V) when the output of the switching regulator is out of regulation (less than 95% of its nominal value). In this state it can sink maximum 3 mA. When not low, it can be pulled high to signal that the output of the regulator is in regulation (power good). During power-up, it can be programmed to go high after a certain delay as set by the Delay pin (Pin 5). The maximum rating of this pin must not be exceeded, so if the rail to which it will be pulled-up to is higher than 45 V, a resistive divider must be used instead of a single pull-up resistor, as indicated in Test Circuits .
4	Ground	G	Circuit ground
5	Delay	O	This sets a programmable power-up delay from the moment that the output reaches regulation, to the high signal output (power good) on Pin 3. A capacitor on this pin starts charging up by means on an internal (3 μ A) current source when the regulated output rises to within 5% of its nominal value. Pin 3 goes high (with an external pull-up) when the voltage on the capacitor on Pin 5 exceeds 1.3 V. The voltage on this pin is clamped internally to about 1.7 V. If the regulated output drops out of regulation (less than 95% of its nominal value), the capacitor on Pin 5 is rapidly discharged internally and Pin 3 will be forced low in about 1/1000th of the set power-up delay time.
6	Feedback	I	Senses the regulated output voltage to complete the feedback loop. This pin is directly connected to the Output for the fixed voltage versions, but is set to 1.23 V by means of a resistive divider from the output for the adjustable version. If a feedforward capacitor is used (adjustable version), then a negative voltage spike is generated on this pin whenever the output is shorted. This happens because the feedforward capacitor cannot discharge fast enough, and since one end of it is dragged to Ground, the other end goes momentarily negative. To prevent the energy rating of this pin from being exceeded, a small-signal Schottky diode to Ground is recommended for DC input voltages above 40 V whenever a feedforward capacitor is present (see Test Circuits). Feedforward capacitor values larger than 0.1 μ F are not recommended for the same reason, whatever be the DC input voltage.

(1) G = Ground, I = Input, O = Output

Pin Functions (continued)

PIN		TYPE ⁽¹⁾	DESCRIPTION
NO.	NAME		
7	$\overline{SD/SS}$	I	<p>Shutdown/Soft-start: The regulator is in shutdown mode, drawing about 90 μA, when this pin is driven to a low level (≤ 0.6 V), and is in normal operation when this Pin is left floating (internal-pullup) or driven to a high level (≥ 2 V). The typical value of the threshold is 1.3 V and the pin is internally clamped to a maximum of about 7 V. If it is driven higher than the clamp voltage, it must be ensured by means of an external resistor that the current into the pin does not exceed 1 mA. The duty cycle is minimum (0%) if this Pin is below 1.8 V, and increases as the voltage on the pin is increased. The maximum duty cycle (100%) occurs when this pin is at 2.8 V or higher. So adding a capacitor to this pin produces a soft-start feature. An internal current source will charge the capacitor from zero to its internally clamped value. The charging current is about 5 μA when the pin is below 1.3 V but is reduced to only 1.6 μA above 1.3 V, so as to allow the use of smaller soft-start capacitors.</p>

6 Specifications

6.1 Absolute Maximum Ratings

over operating free-air temperature range (unless otherwise noted)⁽¹⁾

			MIN	MAX	UNIT
Supply voltage, V_{IN}				63	V
\overline{SD}/SS pin input voltage ⁽²⁾				6	V
Delay pin voltage ⁽²⁾				1.5	V
Flag pin voltage			-0.3	45	V
Feedback pin voltage			-0.3	25	V
Output voltage to ground, steady-state				-1	V
Power dissipation			Internally limited		
Lead temperature	S package	Vapor phase (60 s)		215	°C
		Infrared (10 s)		245	
	T package, soldering (10 s)		260		
Maximum junction temperature				150	°C
Storage temperature, T_{stg}			-65	150	°C

- (1) Stresses beyond those listed under *Absolute Maximum Ratings* may cause permanent damage to the device. These are stress ratings only, which do not imply functional operation of the device at these or any other conditions beyond those indicated under *Recommended Operating Conditions*. Exposure to absolute-maximum-rated conditions for extended periods may affect device reliability.
- (2) Voltage internally clamped. If clamp voltage is exceeded, limit current to a maximum of 1 mA.

6.2 ESD Ratings

			VALUE	UNIT
V_{ESD}	Electrostatic discharge	Human-body model (HBM), per ANSI/ESDA/JEDEC JS-001 ⁽¹⁾	±2000	V

- (1) JEDEC document JEP155 states that 500-V HBM allows safe manufacturing with a standard ESD control process.

6.3 Recommended Operating Conditions

over operating free-air temperature range (unless otherwise noted)

			MIN	MAX	UNIT
	Supply voltage		4.5	60	V
T_J	Temperature		-40	125	°C

6.4 Thermal Information

THERMAL METRIC ⁽¹⁾		LM2590HV		UNIT
		NDZ (TO-220)	KTW (TO-263)	
		7 PINS	7 PINS	
$R_{\theta JA}$	Junction-to-ambient thermal resistance	See ⁽²⁾	50	°C/W
		See ⁽³⁾	—	
		See ⁽⁴⁾	30	
		See ⁽⁵⁾	20	
$R_{\theta JC}$	Junction-to-case thermal resistance	2	2	°C/W

- (1) For more information about traditional and new thermal metrics, see the [Semiconductor and IC Package Thermal Metrics](#) application report.
- (2) Junction to ambient thermal resistance (no external heat sink) for the package mounted TO-220 package mounted vertically, with the leads soldered to a printed-circuit board with (1 oz.) copper area of approximately 1 in².
- (3) Junction to ambient thermal resistance with the TO-263 package tab soldered to a single sided printed-circuit board with 0.5 in² of (1 oz.) copper area.
- (4) Junction to ambient thermal resistance with the TO-263 package tab soldered to a single sided printed-circuit board with 2.5 in² of (1 oz.) copper area.
- (5) Junction to ambient thermal resistance with the TO-263 package tab soldered to a double sided printed circuit board with 3 in 2 of (1 oz.) copper area on the LM2590HVS side of the board, and approximately 16 in² of copper on the other side of the PCB. See [Application Information](#) in this data sheet.

6.5 Electrical Characteristics

 $T_J = 25^\circ\text{C}$, $V_{IN} = 12\text{ V}$ for the 3.3-V, 5-V, and adjustable version, and $I_{LOAD} = 500\text{ mA}$ (unless otherwise noted)

PARAMETER		TEST CONDITIONS		MIN ⁽¹⁾	TYP ⁽²⁾	MAX ⁽¹⁾	UNIT
I_b	Feedback bias current	Adjustable version only, $V_{FB} = 1.3\text{ V}$	$T_J = 25^\circ\text{C}$	10	50		nA
			$T_J = -40^\circ\text{C}$ to 125°C			100	
f_O	Oscillator frequency ⁽³⁾		$T_J = 25^\circ\text{C}$	127	150	173	kHz
			$T_J = -40^\circ\text{C}$ to 125°C	110		173	
V_{SAT}	Saturation voltage		$I_{OUT} = 1\text{ A}$ ⁽⁴⁾⁽⁵⁾	1.2	0.95	1.3	V
DC	Max duty cycle (ON) ⁽⁵⁾			100%			
	Min duty cycle (OFF) ⁽⁶⁾			0%			
I_{CLIM}	Switch current limit	Peak current ⁽⁴⁾⁽⁵⁾	$T_J = 25^\circ\text{C}$	1.3	1.9	2.8	A
			$T_J = -40^\circ\text{C}$ to 125°C	1.2		3	
I_L	Output leakage current	$V_{IN} = 60\text{ V}$ ⁽⁴⁾⁽⁶⁾	Output = 0 V			50	μA
			Output = -1 V		5	30	mA
I_Q	Operating quiescent current		$\overline{SD/SS}$ pin open ⁽⁶⁾		5	10	mA
I_{STBY}	Standby quiescent current	$\overline{SD/SS}$ pin = 0 V, $V_{IN} = 60\text{ V}$	$T_J = 25^\circ\text{C}$		90	200	μA
			$T_J = -40^\circ\text{C}$ to 125°C			250	
SHUTDOWN AND SOFT-START CONTROL (see Test Circuits)							
V_{SD}	Shutdown threshold voltage		$T_J = 25^\circ\text{C}$		1.3		V
			$T_J = -40^\circ\text{C}$ to 125°C	Low (shutdown mode)		0.6	
				High (soft-start mode)	2		
V_{SS}	Soft-start voltage		$V_{OUT} = 20\%$ of nominal output voltage		2		V
			$V_{OUT} = 100\%$ of nominal output voltage		3		
I_{SD}	Shutdown current		$\overline{V_{SHUTDOWN}} = 0.5\text{ V}$		5	10	μA
I_{SS}	Soft-start current		$V_{\text{Soft-start}} = 2.5\text{ V}$		1.5	5	μA
FLAG AND DELAY CONTROL (see Test Circuits)							
	Regulator dropout detector threshold voltage		Low (flag ON)	92%	96%	98%	
V_{FSAT}	Flag output saturation and voltage		$I_{SINK} = 3\text{ mA}$	0.7	0.3	1	V
I_{FL}	Flag output leakage current		$V_{FLAG} = 60\text{ V}$		0.3		μA
	Delay pin threshold voltage		Low (flag ON)	1.21	1.25		mV
			High (flag OFF) and V_{OUT} regulated		1.25	1.29	
	Delay pin source current		$V_{DELAY} = 0.5\text{ V}$		3	6	mV
	Delay pin saturation		Low (flag ON)	$T_J = 25^\circ\text{C}$	70	350	mV
				$T_J = -40^\circ\text{C}$ to 125°C			

- All limits specified at room temperature and at temperature extremes. All room temperature limits are 100% production tested. All limits at temperature extremes are specified via correlation using standard Statistical Quality Control (SQC) methods. All limits are used to calculate Average Outgoing Quality Level (AOQL).
- Typical numbers are at 25°C and represent the most likely norm.
- The switching frequency is reduced when the second stage current limit is activated. The amount of reduction is determined by the severity of current overload.
- No diode, inductor or capacitor connected to output pin.
- Feedback pin removed from output and connected to 0 V to force the output transistor switch ON.
- Feedback pin removed from output and connected to 12 V for the 3.3-V, 5-V, and the ADJ version to force the output transistor switch OFF.

6.6 Electrical Characteristics – 3.3-V Version

 $T_J = 25^\circ\text{C}$ (unless otherwise noted)⁽¹⁾

PARAMETER	TEST CONDITIONS	MIN ⁽²⁾	TYP ⁽³⁾	MAX ⁽²⁾	UNIT	
V_{OUT} Output voltage	$4.5\text{ V} \leq V_{IN} \leq 60\text{ V}$, $0.2\text{ A} \leq I_{LOAD} \leq 1\text{ A}$	$T_J = 25^\circ\text{C}$	3.168	3.3	3.432	V
		$T_J = -40^\circ\text{C}$ to 125°C	3.135		3.465	
η Efficiency	$V_{IN} = 12\text{ V}$, $I_{LOAD} = 1\text{ A}$	77%				

- (1) External components such as the catch diode, inductor, input and output capacitors can affect switching regulator system performance. When the LM2590HV is used as shown in [Test Circuits](#), system performance will be as shown in system parameters section of [Electrical Characteristics](#).
- (2) All limits specified at room temperature and at temperature extremes. All room temperature limits are 100% production tested. All limits at temperature extremes are specified via correlation using standard Statistical Quality Control (SQC) methods. All limits are used to calculate Average Outgoing Quality Level (AOQL).
- (3) Typical numbers are at 25°C and represent the most likely norm.

6.7 Electrical Characteristics – 5-V Version

 $T_J = 25^\circ\text{C}$ (unless otherwise noted)⁽¹⁾

PARAMETER	TEST CONDITIONS	MIN ⁽²⁾	TYP ⁽³⁾	MAX ⁽²⁾	UNIT	
V_{OUT} Output voltage	$7\text{ V} \leq V_{IN} \leq 60\text{ V}$, $0.2\text{ A} \leq I_{LOAD} \leq 1\text{ A}$	$T_J = 25^\circ\text{C}$	4.8	5	5.2	V
		$T_J = -40^\circ\text{C}$ to 125°C	4.75		5.25	
η Efficiency	$V_{IN} = 12\text{ V}$, $I_{LOAD} = 1\text{ A}$	82%				

- (1) External components such as the catch diode, inductor, input and output capacitors can affect switching regulator system performance. When the LM2590HV is used as shown in [Test Circuits](#), system performance will be as shown in system parameters section of [Electrical Characteristics](#).
- (2) All limits specified at room temperature and at temperature extremes. All room temperature limits are 100% production tested. All limits at temperature extremes are specified via correlation using standard Statistical Quality Control (SQC) methods. All limits are used to calculate Average Outgoing Quality Level (AOQL).
- (3) Typical numbers are at 25°C and represent the most likely norm.

6.8 Electrical Characteristics – Adjustable Version

 $T_J = 25^\circ\text{C}$ (unless otherwise noted)⁽¹⁾

PARAMETER	TEST CONDITIONS	MIN ⁽²⁾	TYP ⁽³⁾	MAX ⁽²⁾	UNIT	
V_{FB} Feedback voltage	$4.5\text{ V} \leq V_{IN} \leq 60\text{ V}$, $0.2\text{ A} \leq I_{LOAD} \leq 1\text{ A}$, V_{OUT} programmed for 3 V (see Test Circuits)	$T_J = 25^\circ\text{C}$	1.193	1.23	1.267	V
		$T_J = -40^\circ\text{C}$ to 125°C	1.18		1.28	
η Efficiency	$V_{IN} = 12\text{ V}$, $V_{OUT} = 3\text{ V}$, $I_{LOAD} = 1\text{ A}$	76%				

- (1) External components such as the catch diode, inductor, input and output capacitors can affect switching regulator system performance. When the LM2590HV is used as shown in [Test Circuits](#), system performance will be as shown in system parameters section of [Electrical Characteristics](#).
- (2) All limits specified at room temperature and at temperature extremes. All room temperature limits are 100% production tested. All limits at temperature extremes are specified via correlation using standard Statistical Quality Control (SQC) methods. All limits are used to calculate Average Outgoing Quality Level (AOQL).
- (3) Typical numbers are at 25°C and represent the most likely norm.

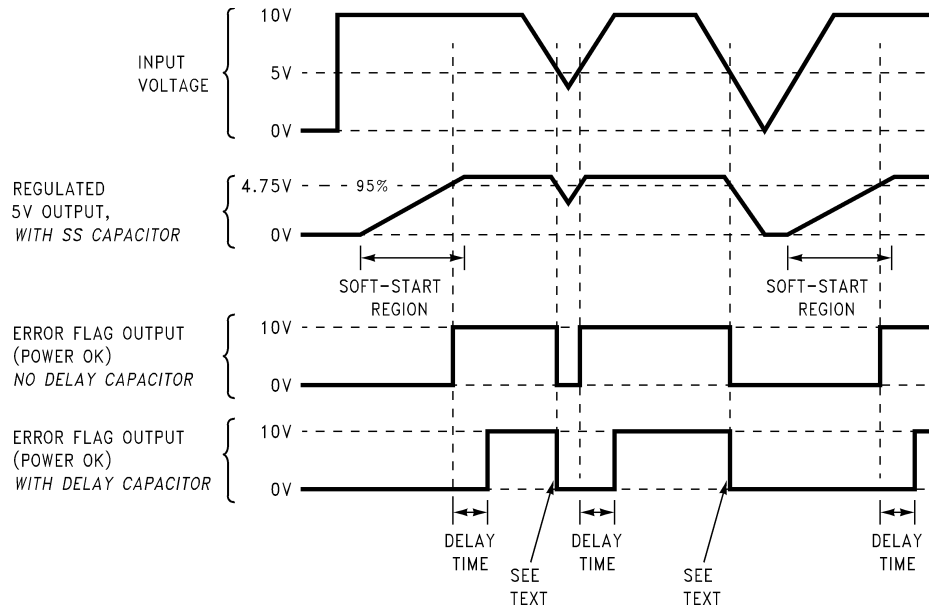
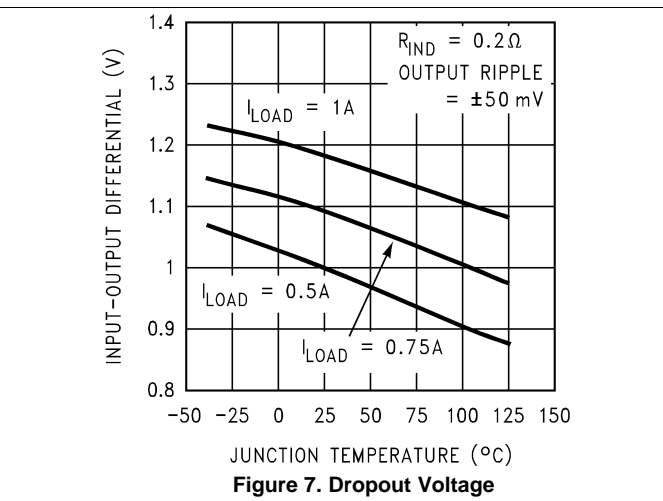
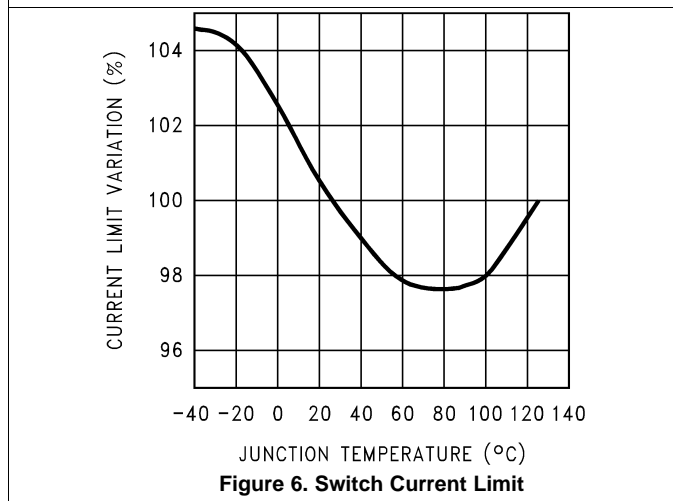
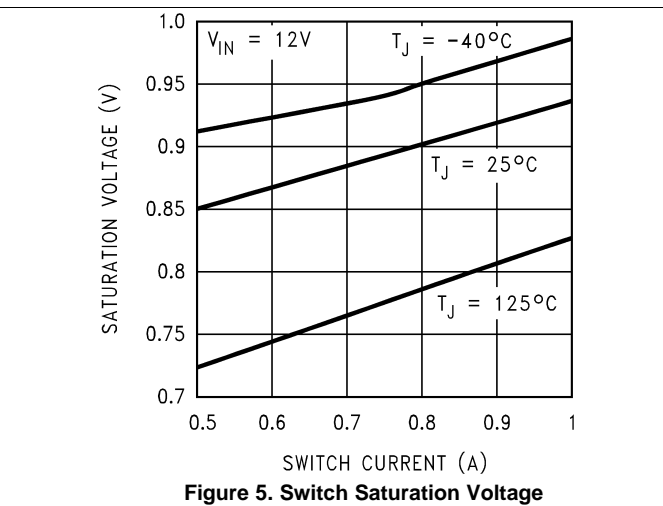
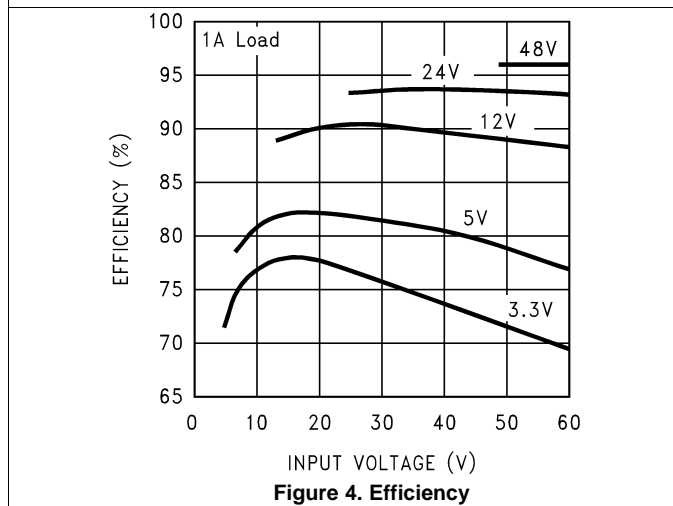
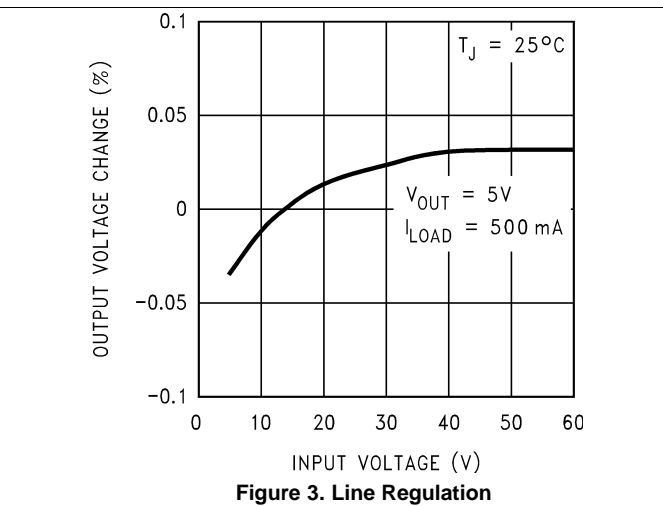
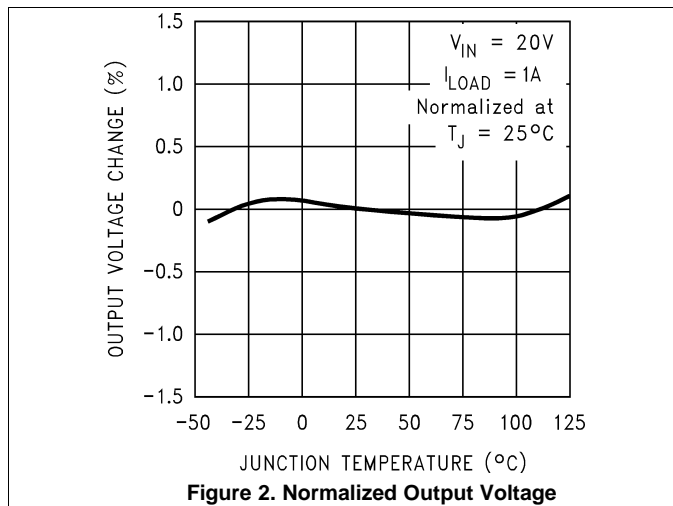

Figure 1. Timing Diagram for 5-V Output

6.9 Typical Characteristics



Typical Characteristics (continued)

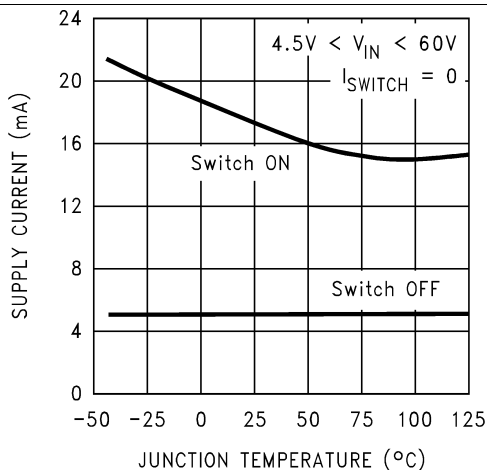

Figure 8. Operating Quiescent Current

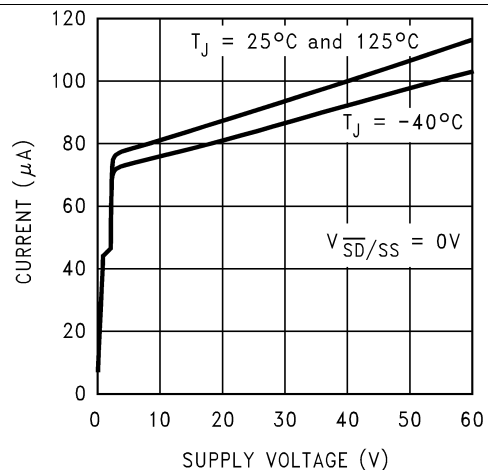

Figure 9. Shutdown Quiescent Current

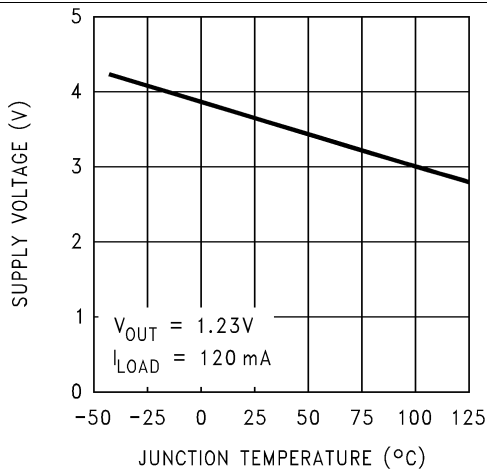

Figure 10. Minimum Operating Supply Voltage

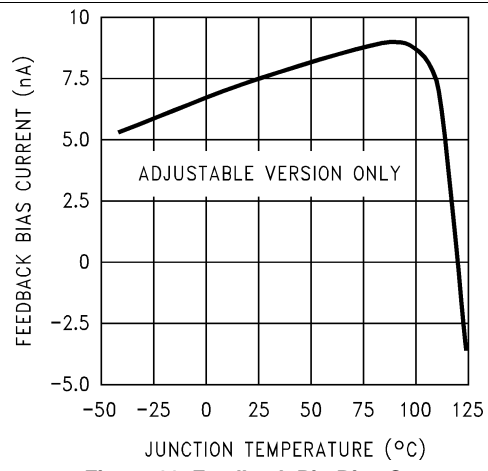

Figure 11. Feedback Pin Bias Current

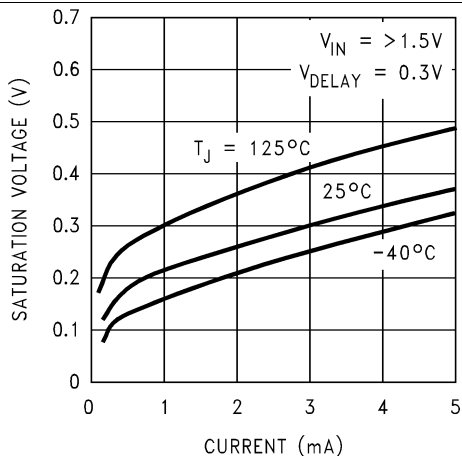

Figure 12. Flag Saturation Voltage

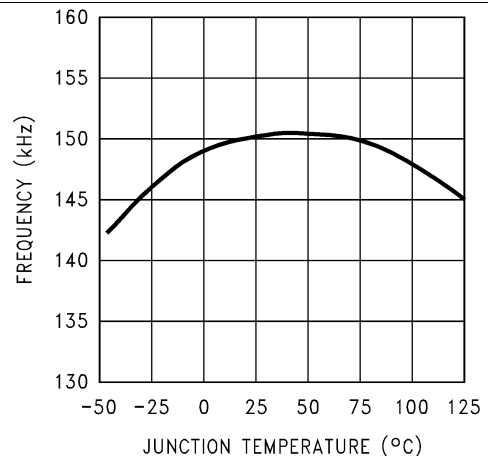

Figure 13. Switching Frequency

Typical Characteristics (continued)

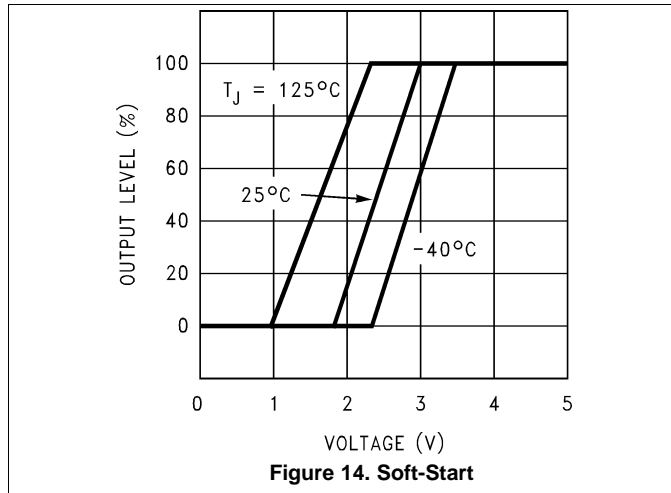

Figure 14. Soft-Start

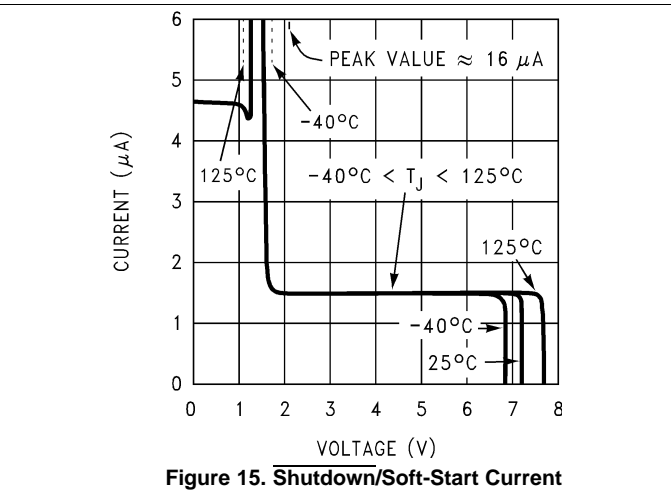

Figure 15. Shutdown/Soft-Start Current

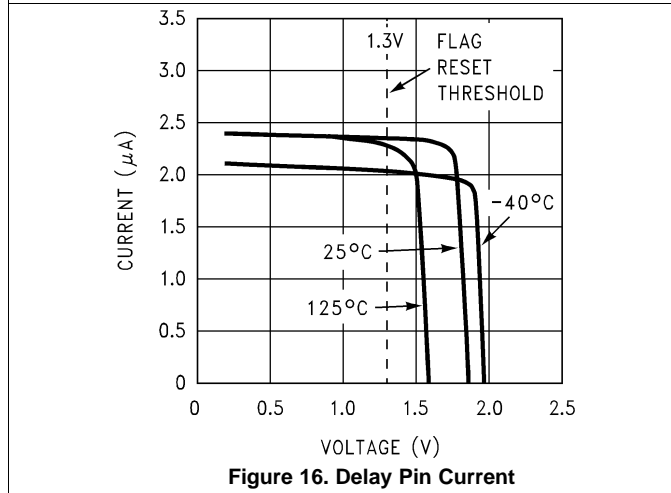

Figure 16. Delay Pin Current

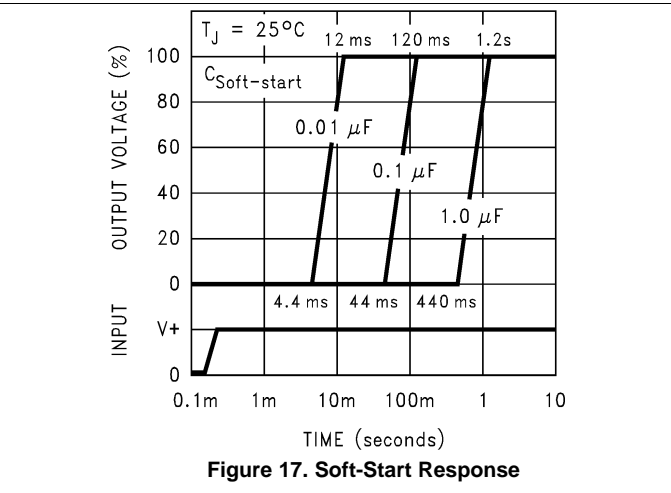

Figure 17. Soft-Start Response

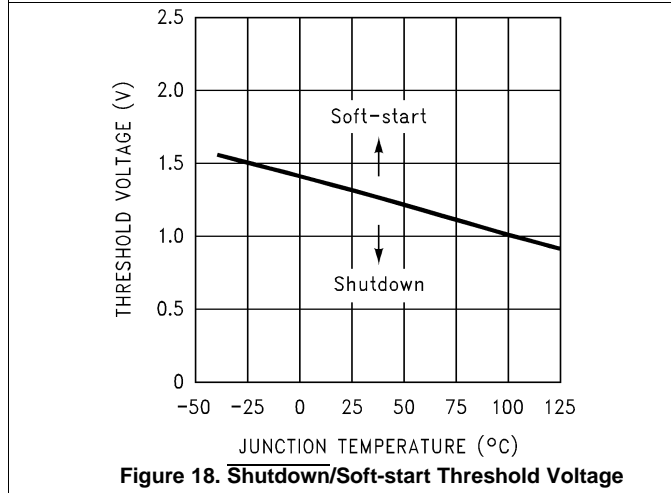

Figure 18. Shutdown/Soft-start Threshold Voltage

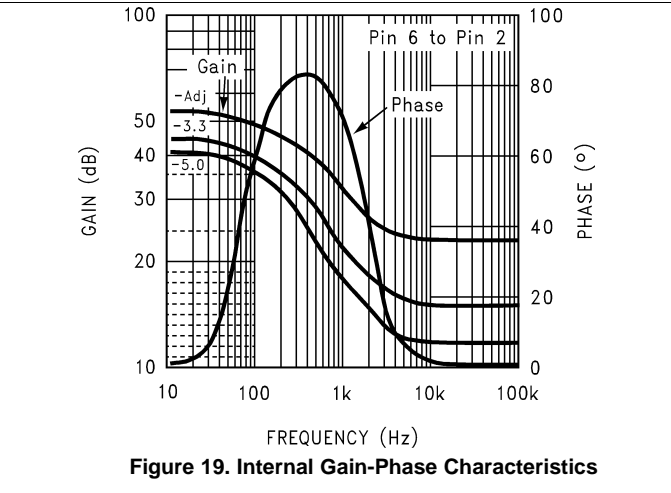
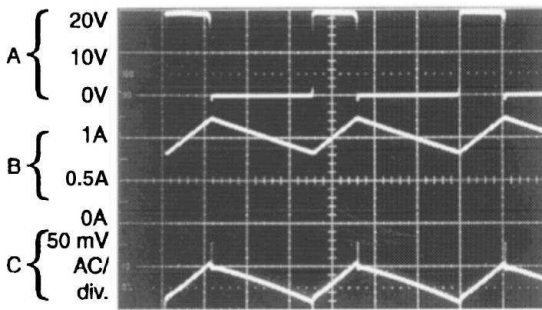

Figure 19. Internal Gain-Phase Characteristics

Typical Characteristics (continued)



Horizontal Time Base: 2 μ s/div.
 $V_{IN} = 20\text{ V}$, $V_{OUT} = 5\text{ V}$, $I_{LOAD} = 1\text{ A}$,
 $L = 52\text{ }\mu\text{H}$, $C_{OUT} = 100\text{ }\mu\text{F}$, $C_{OUT}\text{ ESR} = 100\text{ m}\Omega$
 Output Pin Voltage, 10 V/div.
 Inductor Current, 0.5 A/div.
 Output Ripple Voltage, 50 mV/div.

Figure 20. Continuous Mode Switching Waveforms

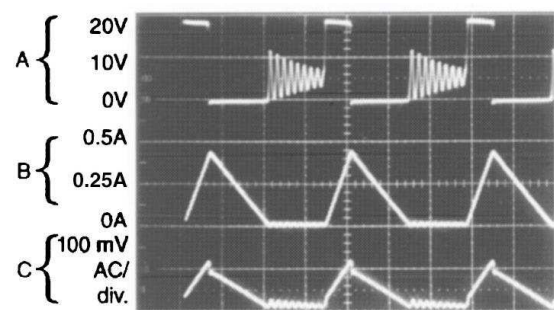

Horizontal Time Base: 2 μ s/div.
 $V_{IN} = 20\text{ V}$, $V_{OUT} = 5\text{ V}$, $I_{LOAD} = 250\text{ mA}$,
 $L = 52\text{ }\mu\text{H}$, $C_{OUT} = 150\text{ }\mu\text{F}$, $C_{OUT}\text{ ESR} = 100\text{ m}\Omega$
 Output Pin Voltage, 10 V/div.
 Inductor Current, 0.25 A/div.
 Output Ripple Voltage, 100 mV/div.

Figure 21. Discontinuous Mode Switching Waveforms

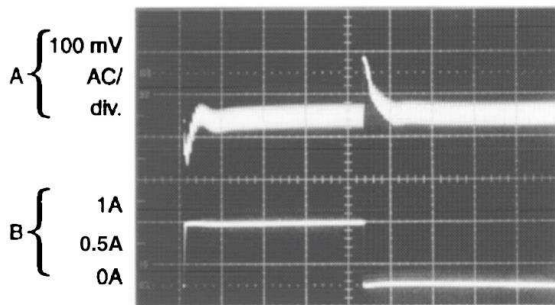

Horizontal Time Base: 50 μ s/div.
 $V_{IN} = 20\text{ V}$, $V_{OUT} = 5\text{ V}$, $I_{LOAD} = 250\text{ mA}$,
 $L = 52\text{ }\mu\text{H}$, $C_{OUT} = 100\text{ }\mu\text{F}$, $C_{OUT}\text{ ESR} = 100\text{ m}\Omega$
 Output Voltage, 100 mV/div. (AC)
 250-mA to 1-A Load Pulse

Figure 22. Load Transient Response for Continuous Mode

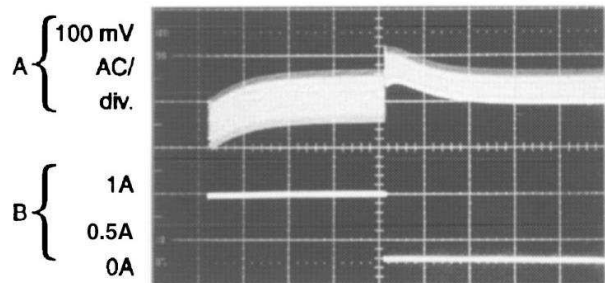

Horizontal Time Base: 200 μ s/div.
 $V_{IN} = 20\text{ V}$, $V_{OUT} = 5\text{ V}$, $I_{LOAD} = 250\text{ mA to }1\text{ A}$,
 $L = 15\text{ }\mu\text{H}$, $C_{OUT} = 150\text{ }\mu\text{F}$, $C_{OUT}\text{ ESR} = 90\text{ m}\Omega$
 Output Voltage, 100 mV/div. (AC)
 250-mA to 1-A Load Pulse

Figure 23. Load Transient Response for Discontinuous Mode

7 Parameter Measurement Information

7.1 Test Circuits

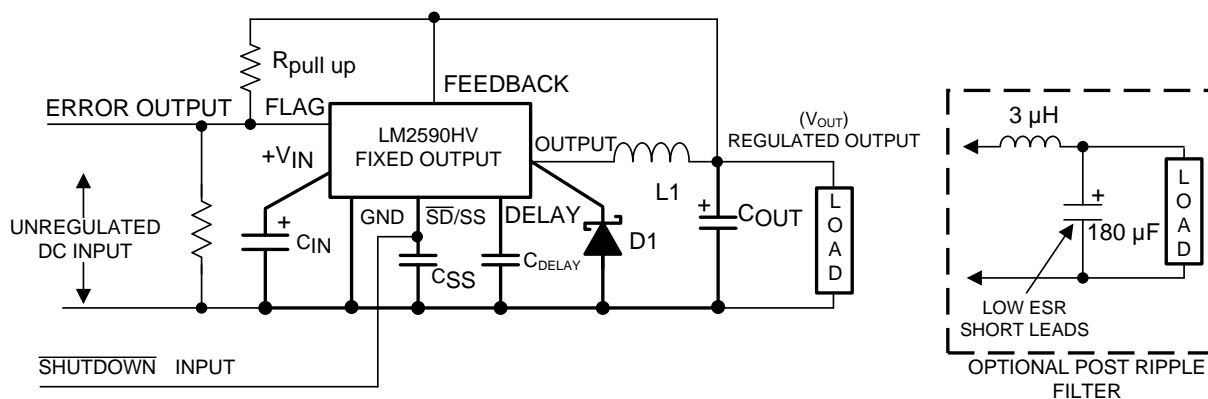

Copyright © 2016, Texas Instruments Incorporated

Component Values shown are for $V_{IN} = 15\text{ V}$,
 $V_{OUT} = 5\text{ V}$, $I_{LOAD} = 1\text{ A}$.
 C_{IN} — 470- μF , 50-V aluminum electrolytic Nichicon *PM Series*
 C_{OUT} — 220- μF , 25-V aluminum electrolytic Nichicon *PM Series*
 $D1$ — 2-A, 60-V Schottky Rectifier, 21DQ06 (international rectifier)
 $L1$ — 68 μH , see [Inductor Selection Procedure](#)

Figure 24. Fixed Output Voltage Versions

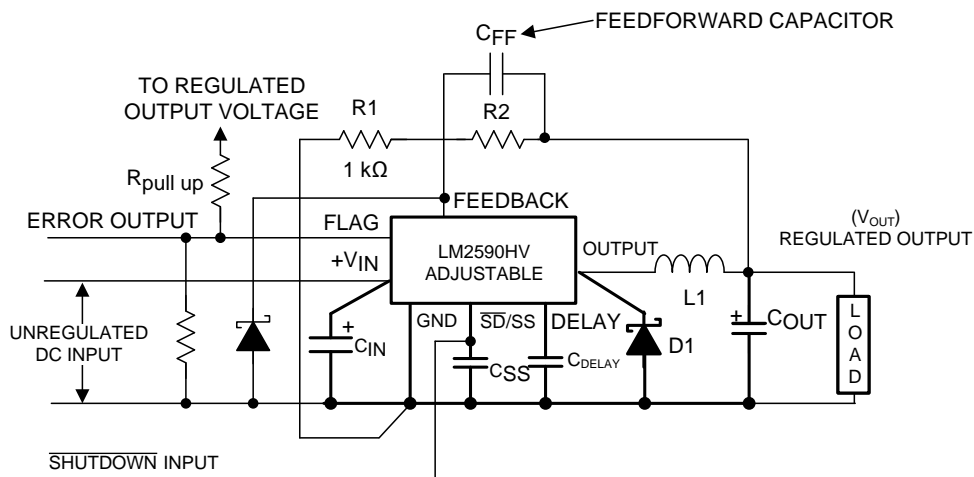
Test Circuits (continued)

Copyright © 2016, Texas Instruments Incorporated

 Select R_1 to be approximately 1 k Ω , use a 1% resistor for best stability.

 Component values shown are for $V_{IN} = 20$ V,

 $V_{OUT} = 10$ V, $I_{LOAD} = 1$ A.

 C_{IN} — 470- μ F, 35-V aluminum electrolytic Nichicon *PM Series*
 C_{OUT} — 220- μ F, 35-V aluminum electrolytic Nichicon *PM Series*

D1 — 2-A, 60-V Schottky Rectifier, 21DQ06 (international rectifier)

 L1 — 100 μ H, see [Inductor Selection Procedure](#)
 R_1 — 1 k Ω , 1%

 R_2 — 7.15 k, 1%

 C_{FF} — 3.3 nF

Typical Values
 C_{SS} — 0.1 μ F

 C_{DELAY} — 0.1 μ F

 $R_{PULL\ UP}$ — 4.7 k (use 22 k if V_{OUT} is ≥ 45 V)

† Resistive divider is required to avoid exceeding maximum rating of 45 V, 3 mA on or into flag pin.

†† Small signal Schottky diode to prevent damage to feedback pin by negative spike when output is shorted.

 Required if $V_{IN} > 40$ V

Figure 25. Adjustable Output Voltage Versions

8 Detailed Description

8.1 Overview

The LM2590HV SIMPLE SWITCHER® regulator is an easy to use non-synchronous step-down DC-DC converter with a wide input voltage range up to 60 V. It is capable of delivering up to 1-A DC load current with excellent line and load regulation. These devices are available in fixed output voltages of 3.3-V, 5-V, 12-V and an adjustable output version. The family requires few external components and the pin arrangement was designed for simple, optimum PCB layout.

8.2 Functional Block Diagram

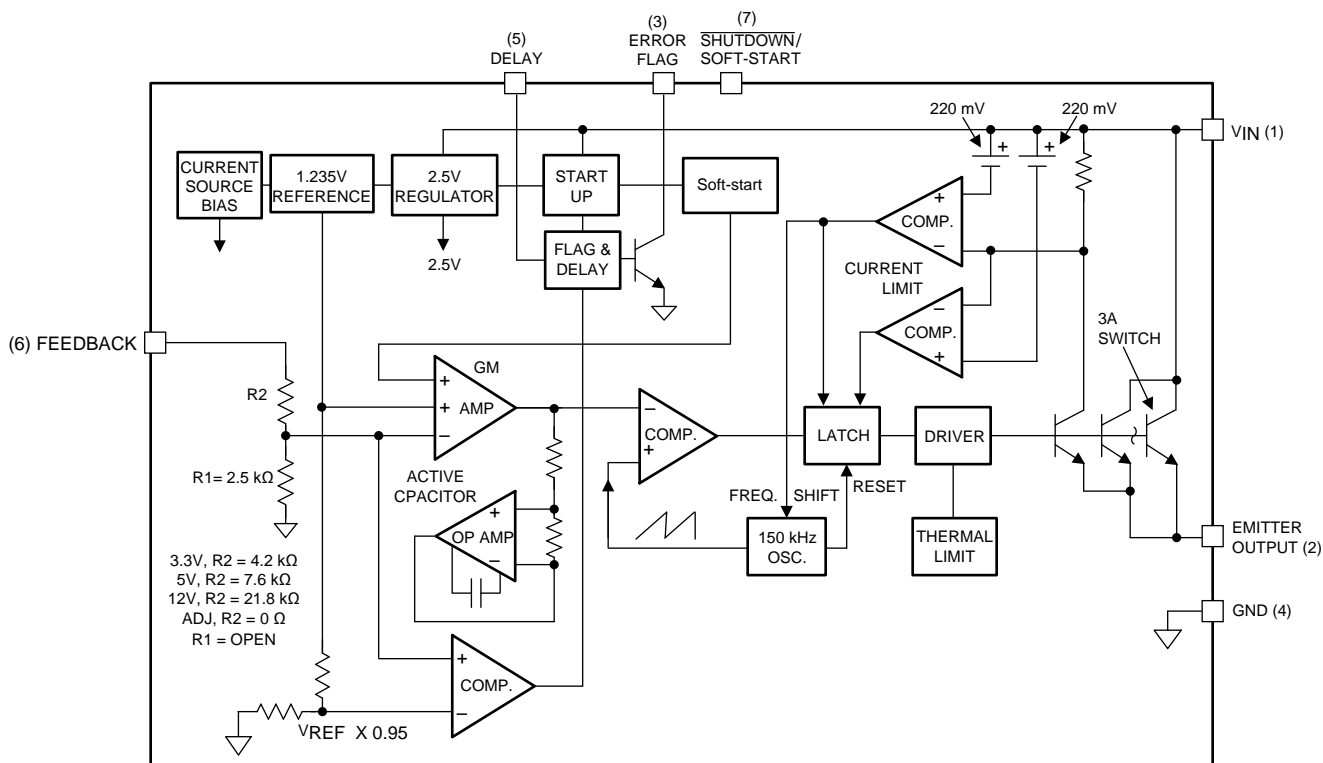

8.3 Feature Description

8.3.1 Undervoltage Lockout

Some applications require the regulator to remain off until the input voltage reaches a predetermined voltage. [Figure 26](#) contains an undervoltage lockout circuit for a buck configuration, while [Figure 27](#) and [Figure 28](#) are for the inverting types (only the circuitry pertaining to the undervoltage lockout is shown). [Figure 26](#) uses a Zener diode to establish the threshold voltage when the switcher begins operating. When the input voltage is less than the Zener voltage, resistors R1 and R2 hold the SHUTDOWN/SOFT-START pin low, keeping the regulator in the shutdown mode. As the input voltage exceeds the Zener voltage, the Zener conducts, pulling the SHUTDOWN/SOFT-START pin high, allowing the regulator to begin switching. The threshold voltage for the undervoltage lockout feature is approximately 1.5 V greater than the Zener voltage.

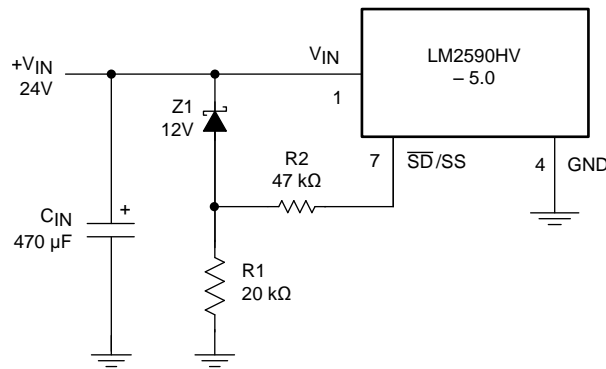
Feature Description (continued)

Copyright © 2016, Texas Instruments Incorporated

Figure 26. Undervoltage Lockout for a Buck Regulator

Figure 27 and Figure 28 apply the same feature to an inverting circuit. Figure 27 features a constant threshold voltage for turn on and turn off (Zener voltage plus approximately 1 V). If hysteresis is needed, the circuit in Figure 28 has a turn ON voltage which is different than the turn OFF voltage. The amount of hysteresis is approximately equal to the value of the output voltage. Since the $\overline{SD/SS}$ pin has an internal 7-V Zener clamp, R2 is needed to limit the current into this pin to approximately 1 mA when Q1 is on.

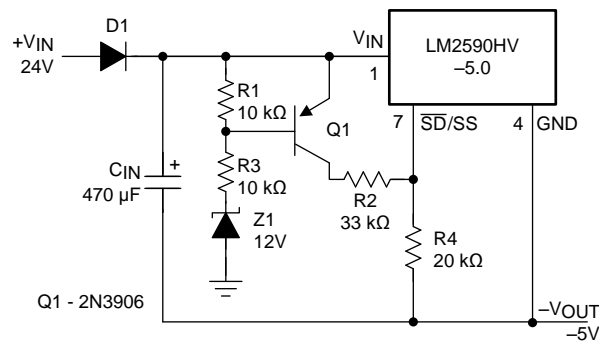

Copyright © 2016, Texas Instruments Incorporated

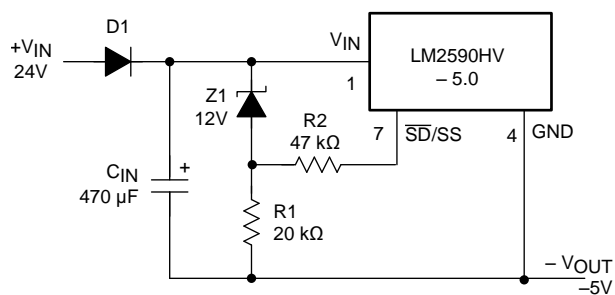
Figure 27. Undervoltage Lockout Without Hysteresis for an Inverting Regulator

Copyright © 2016, Texas Instruments Incorporated

Figure 28. Undervoltage Lockout With Hysteresis for an Inverting Regulator

Feature Description (continued)

8.3.2 SHUTDOWN/SOFT-START

This reduction in start up current is useful in situations where the input power source is limited in the amount of current it can deliver. In some applications Soft-start can be used to replace undervoltage lockout or delayed startup functions.

If a very slow output voltage ramp is desired, the Soft-start capacitor can be made much larger. Many seconds or even minutes are possible.

If only the shutdown feature is needed, the Soft-start capacitor can be eliminated.

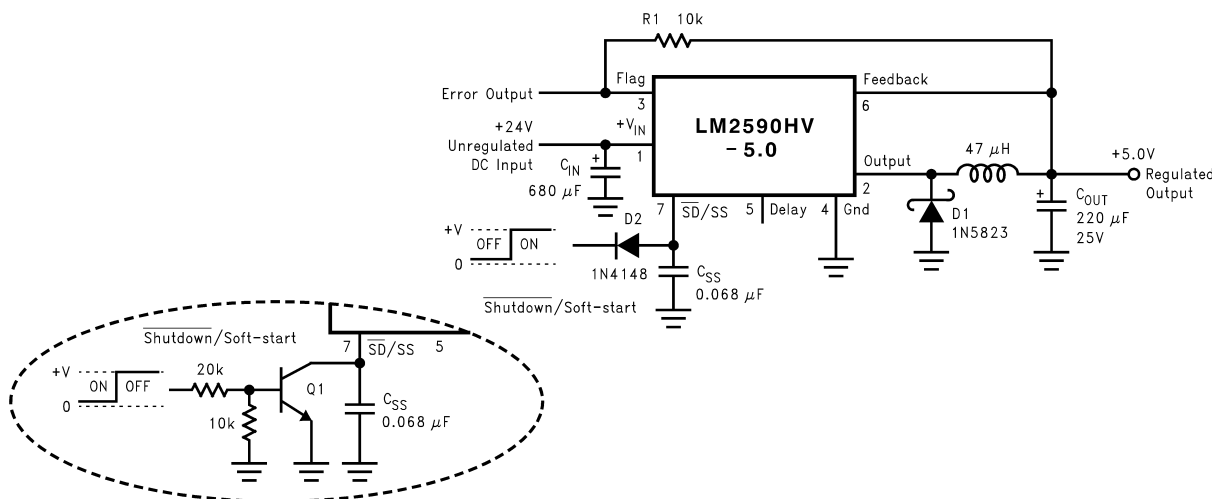

Figure 29. Typical Circuit Using SHUTDOWN/SOFT-START and Error Flag Features

Feature Description (continued)

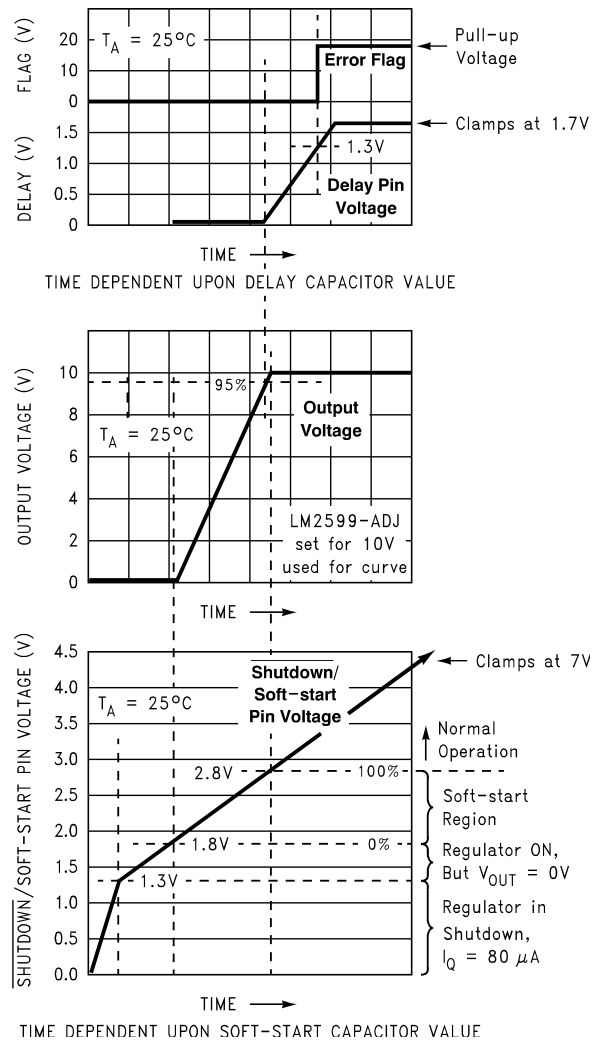

Figure 30. Soft-Start, Delay, Error Output

8.4 Device Functional Modes

8.4.1 Shutdown Mode

The $\overline{\text{SD}}/\text{SS}$ pin provides electrical ON and OFF control for the LM2590HV. When the voltage of this pin is less than 0.6 V, the device is in shutdown mode. The typical standby current in this mode is 90 μA .

8.4.2 Active Mode

When the $\overline{\text{SD}}/\text{SS}$ pin is left floating or pull above 2 V, the device will start switching and the output voltage will rise until it reaches a normal regulation voltage.

9 Application and Implementation

NOTE

Information in the following applications sections is not part of the TI component specification, and TI does not warrant its accuracy or completeness. TI's customers are responsible for determining suitability of components for their purposes. Customers should validate and test their design implementation to confirm system functionality.

9.1 Application Information

9.1.1 Feedforward Capacitor, C_{FF}

(Adjustable output voltage version only)

A feedforward capacitor shown across R2 in [Test Circuits](#) is used when the output voltage is greater than 10 V or when C_{OUT} has a very low ESR. This capacitor adds lead compensation to the feedback loop and increases the phase margin for better loop stability.

If the output voltage ripple is large (>5% of the nominal output voltage), this ripple can be coupled to the feedback pin through the feedforward capacitor and cause the error comparator to trigger the error flag. In this situation, adding a resistor, R_{FF} , in series with the feedforward capacitor, approximately 3 times R1, will attenuate the ripple voltage at the feedback pin.

9.1.2 Input Capacitor, C_{IN}

A low-ESR aluminum or tantalum bypass capacitor is needed between the input pin and ground pin. It must be located near the regulator using short leads. This capacitor prevents large voltage transients from appearing at the input, and provides the instantaneous current needed each time the switch turns on.

The important parameters for the input capacitor are the voltage rating and the RMS current rating. Because of the relatively high RMS currents flowing in the input capacitor of the buck regulator, this capacitor must be chosen for its RMS current rating rather than its capacitance or voltage ratings, although the capacitance value and voltage rating are directly related to the RMS current rating. The voltage rating of the capacitor and its RMS ripple current capability must never be exceeded.

9.1.3 Output Capacitor, C_{OUT}

An output capacitor is required to filter the output and provide regulator loop stability. Low-impedance or low-ESR Electrolytic or solid tantalum capacitors designed for switching regulator applications must be used. When selecting an output capacitor, the important capacitor parameters are; the 100-kHz equivalent series resistance (ESR), the RMS ripple current rating, voltage rating, and capacitance value. For the output capacitor, the ESR value is the most important parameter. The ESR must generally not be less than 100 mΩ or there will be loop instability. If the ESR is too large, efficiency and output voltage ripple are effected. So ESR must be chosen carefully.

9.1.4 Catch Diode

Buck regulators require a diode to provide a return path for the inductor current when the switch turns off. This must be a fast diode and must be located close to the LM2590HV using short leads and short printed circuit traces.

Because of their very fast switching speed and low forward voltage drop, Schottky diodes provide the best performance, especially in low output voltage applications (5 V and lower). Ultra-fast recovery, or high-efficiency rectifiers are also a good choice, but some types with an abrupt turnoff characteristic may cause instability or EMI problems. Ultra-fast recovery diodes typically have reverse recovery times of 50 ns or less. The diode must be chosen for its average or RMS current rating and maximum voltage rating. The voltage rating of the diode must be greater than the DC input voltage (not the output voltage).

Application Information (continued)

9.1.5 Inverting Regulator

The circuit in [Figure 31](#) converts a positive input voltage to a negative output voltage with a common ground. The circuit operates by bootstrapping the regulator's ground pin to the negative output voltage, then grounding the feedback pin, the regulator senses the inverted output voltage and regulates it.

This example uses the LM2590HV 5-V to generate a -5-V output, but other output voltages are possible by selecting other output voltage versions, including the adjustable version. Since this regulator topology can produce an output voltage that is either greater than or less than the input voltage, the maximum output current greatly depends on both the input and output voltage.

To determine how much load current is possible before the internal device current limit is reached (and power limiting occurs), the system must be evaluated as a buck-boost configuration rather than as a buck. The peak switch current in Amperes, for such a configuration is given in [Equation 1](#).

$$I_{PEAK} = I_{LOAD} \times \left(\frac{V_{IN} + V_{OUT}}{V_{IN}} \right) + \frac{V_{IN} \times V_{OUT} \times 10^6}{2 \times L \times f \times (V_{IN} + V_{OUT})}$$

where

- L is in μH
- f is in Hz

(1)

The maximum possible load current, I_{LOAD} , is limited by the requirement that $I_{PEAK} \leq I_{CLIM}$. While checking for this, take I_{CLIM} to be the lowest possible current limit value (minimum across tolerance and temperature is 2.3 A for the LM2590HV). Also to account for inductor tolerances, we must take the minimum value of Inductance for L in the equation above (typically 20% less than the nominal value). Further, the above equation disregards the drop across the Switch and the diode. This is equivalent to assuming 100% efficiency, which is never so. Therefore expect I_{PEAK} to be an additional 10% to 20% higher than calculated from the above equation. Refer to [AN-1197 Selecting Inductors for Buck Converters](#) (SNVA038) for examples based on positive to negative configuration. The maximum voltage appearing across the regulator is the absolute sum of the input and output voltage, and this must be limited to a maximum of 60 V. In this example, when converting 20 V to -5 V, the regulator would see 25 V between the input pin and ground pin. The LM2590HV has a maximum input voltage rating of 60 V. An additional diode is required in this regulator configuration. Diode D1 is used to isolate input voltage ripple or noise from coupling through the C_{IN} capacitor to the output, under light or no load conditions. Also, this diode isolation changes the topology to closely resemble a buck configuration thus providing good closed loop stability. A Schottky diode is recommended for low input voltages, (because of its lower voltage drop) but for higher input voltages, a IN5400 diode could be used. Because of differences in the operation of the inverting regulator, the standard design procedure is not used to select the inductor value. In the majority of designs, a 33- μH , 4-A inductor is the best choice. Capacitor selection can also be narrowed down to just a few values. This type of inverting regulator can require relatively large amounts of input current when starting up, even with light loads. Input currents as high as the LM2590HV current limit (approximately 4 A) are needed for 2 ms or more, until the output reaches its nominal output voltage. The actual time depends on the output voltage and the size of the output capacitor. Input power sources that are current limited or sources that can not deliver these currents without getting loaded down, may not work correctly. Because of the relatively high startup currents required by the inverting topology, the soft-start feature shown in [Figure 31](#) is recommended. Also shown in [Figure 31](#) are several shutdown methods for the inverting configuration. With the inverting configuration, some level shifting is required, because the ground pin of the regulator is no longer at ground, but is now at the negative output voltage. The shutdown methods shown accept ground referenced shutdown signals.

Application Information (continued)

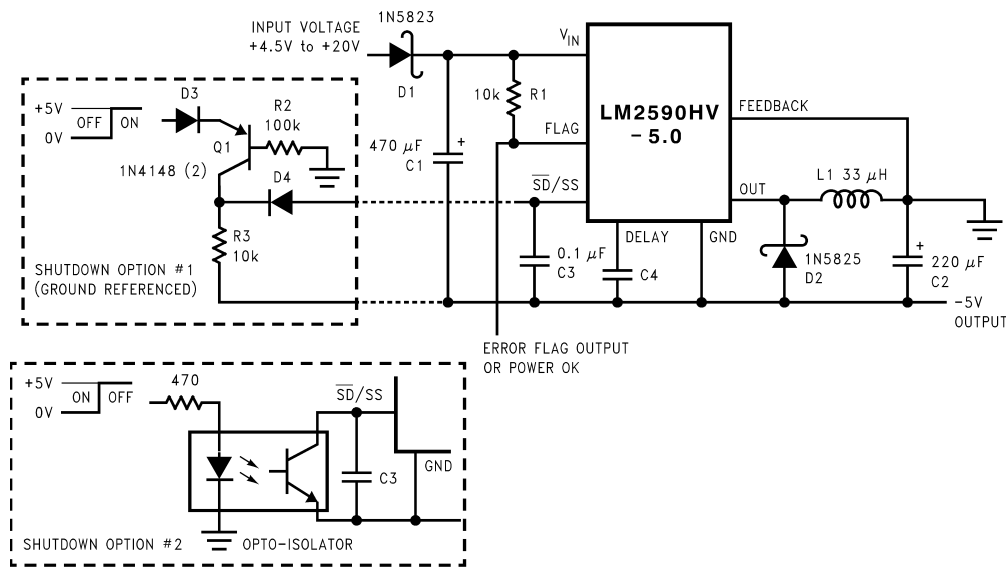
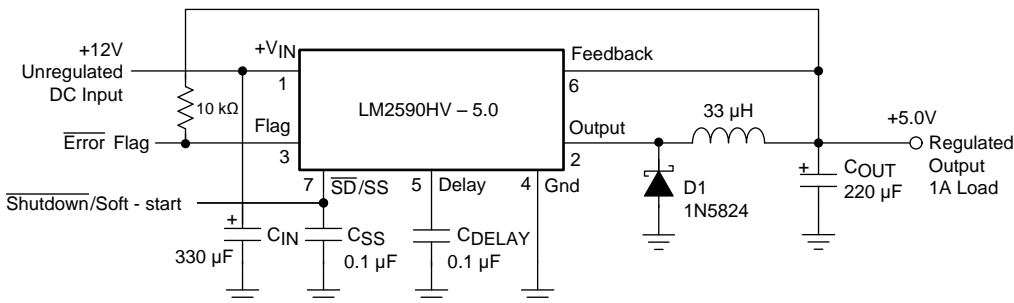

Figure 31. Inverting, -5-V Regulator With Shutdown and Soft-Start

9.2 Typical Application



Copyright © 2016, Texas Instruments Incorporated

Figure 32. LM2590HV 5-V Example Application

9.2.1 Design Requirements

Table 1 lists the example values for this typical application.

Table 1. Design Parameters

PARAMETER	VALUE
Regulated output voltage (3.3 V, 5 V, or adjustable), V_{OUT}	5 V
Maximum input voltage, $V_{IN(max)}$	24 V
Maximum load current, $I_{LOAD(max)}$	1 A
Switching frequency, F	Fixed at a nominal 150 kHz

9.2.2 Detailed Design Procedure

9.2.2.1 Inductor Selection Procedure

For a quick-start, refer to the nomographs provided in [Figure 33](#) to [Figure 35](#). To widen the choices to a more general selection of available inductors, the nomographs provide the required inductance and also the energy in the core expressed in microjoules (μJ), as an alternative to just prescribing custom parts. The following points need to be highlighted:

1. The energy values shown on the nomographs apply to steady operation at the corresponding x-coordinate (rated maximum load current). However under start-up, without soft-start, or a short-circuit on the output, the current in the inductor will momentarily/repetitively hit the current limit I_{CLIM} of the device, and this current could be much higher than the rated load, I_{LOAD} . This represents an overload situation, and can cause the Inductor to saturate (if it has been designed only to handle the energy of steady operation). However most types of core structures used for such applications have a large inherent air gap (for example powdered iron types or ferrite rod inductors), and so the inductance does not fall off too sharply under an overload. The device is usually able to protect itself by not allowing the current to ever exceed I_{CLIM} . But if the DC input voltage to the regulator is over 40 V, the current can slew up so fast under core saturation, that the device may not be able to act fast enough to restrict the current. The current can then rise without limit till destruction of the device takes place. Therefore to ensure reliability, TI recommends that if the DC input voltage exceeds 40 V the inductor must always be sized to handle an instantaneous current equal to I_{CLIM} without saturating, irrespective of the type of core structure or material.

2. Use [Equation 2](#) to calculate the energy under steady operation.

$$e = \frac{1}{2} \times L \times I_{\text{PEAK}}^2 \quad \mu\text{J}$$

where

- L is in μH
 - I_{PEAK} is the peak of the inductor current waveform with the regulator delivering I_{LOAD}
- (2)

These are the energy values shown in the nomographs. See [Example 1](#).

3. The energy under overload is [Equation 3](#).

$$e_{\text{CLIM}} = \frac{1}{2} \times L \times I_{\text{CLIM}}^2 \quad \mu\text{J}$$
(3)

If $V_{\text{IN}} > 40 \text{ V}$, the inductor must be sized to handle e_{CLIM} instead of the steady energy values. The worst case I_{CLIM} for the LM2590HV is 3 A. The energy rating depends on the inductance. See [Example 2](#).

4. The nomographs were generated by allowing a greater amount of percentage current ripple in the Inductor as the maximum rated load decreases (see [Figure 36](#)). This was done to permit the use of smaller inductors at light loads. However, [Figure 36](#) shows only the *median* value of the current ripple. In reality there may be a great spread around this because the nomographs approximate the exact calculated inductance to standard available values. Refer to [AN-1197 Selecting Inductors for Buck Converters](#) (SNVA038) for detailed calculations if a certain maximum inductor current ripple is required for various possible reasons. Also consider the rather wide tolerance on the nominal inductance of commercial inductors.
5. [Figure 35](#) shows the inductor selection curves for the Adjustable version. The y-axis is Et , in $V\mu\text{secs}$. It is the applied volts across the inductor during the ON time of the switch ($V_{\text{IN}} - V_{\text{SAT}} - V_{\text{OUT}}$) multiplied by the time for which the switch is on in μsecs . See [Example 3](#).

9.2.2.1.1 Example 1: $V_{\text{IN}} \leq 40 \text{ V}$, 5-V Version, $V_{\text{IN}} = 24 \text{ V}$, Output = 5 V at 1 A

1. A first pass inductor selection is based upon Inductance and rated max load current. We choose an inductor with the Inductance value indicated by the nomograph (see [Figure 34](#)) and a current rating equal to the maximum load current. We therefore quick-select a 68- μH , 1-A inductor (designed for 150 kHz operation) for this application
2. We must confirm that it is rated to handle 50 μJ (see [Figure 34](#)) by either estimating the peak current or by a detailed calculation as shown in [AN-1197 Selecting Inductors for Buck Converters](#) (SNVA038), and also that the losses are acceptable.

9.2.2.1.2 Example 2: $V_{\text{IN}} > 40 \text{ V}$, 5-V Version, $V_{\text{IN}} = 48 \text{ V}$, Output = 5 V at 1.5 A

1. A first pass inductor selection is based upon Inductance and the switch current limit. We choose an inductor

with the Inductance value indicated by the nomograph (see [Figure 34](#)) and a current rating equal to I_{CLIM} . We therefore quick-select a 68- μ H, 4-A inductor (designed for 150 kHz operation) for this application.

2. We must confirm that it is rated to handle e_{CLIM} by the procedure shown in [AN-1197 Selecting Inductors for Buck Converters](#) (SNVA038) and that the losses are acceptable. Here e_{CLIM} is [Equation 4](#).

$$e_{CLIM} = \frac{1}{2} \times 100 \times 3^2 = 450 \mu\text{J} \quad (4)$$

9.2.2.1.3 Example 3: $V_{IN} \leq 40$ V, Adjustable Version, $V_{IN} = 20$ V, Output = 10 V at 2 A

1. Since input voltage is less than 40 V, a first pass inductor selection is based upon Inductance and rated max load current. We choose an inductor with the Inductance value indicated by the nomograph [Figure 35](#) and a current rating equal to the maximum load. But we first need to calculate Et for the given application. The Duty cycle is [Equation 5](#).

$$D = \frac{V_{OUT} + V_D}{V_{IN} - V_{SAT} + V_D}$$

where

- V_D is the drop across the catch diode (0.5 V for a Schottky)
- V_{SAT} the drop across the switch (1.5 V)

So this yields [Equation 6](#).

$$D = \frac{10 + 0.5}{20 - 1.5 + 0.5} = 0.55 \quad (6)$$

2. The switch ON time is calculated with [Equation 7](#).

$$t_{ON} = \frac{D}{f} \times 10^6 \mu\text{s}$$

where

- f is the switching frequency in Hz

So this yields [Equation 8](#).

$$\begin{aligned} Et &= (V_{IN} - V_{SAT} - V_{OUT}) \times t_{ON} \\ &= (20 - 1.5 - 10) \times \frac{0.55}{150000} \times 10^6 \text{ V}\mu\text{secs} \\ &= 31.3 \text{ V}\mu\text{secs} \end{aligned} \quad (8)$$

3. Therefore, looking at [Figure 33](#), quick-select a 47- μ H, 2-A inductor (designed for 150 kHz operation) for this application.
4. Confirm that it is rated to handle 200 μ J (see [Figure 35](#)) by the procedure shown in [AN-1197 Selecting Inductors for Buck Converters](#) (SNVA038) and that the losses are acceptable. (If the DC Input voltage had been greater than 40 V we would need to consider e_{CLIM} as in [Example 2](#)). This completes the simplified inductor selection procedure. For more general applications and better optimization, refer to [AN-1197 Selecting Inductors for Buck Converters](#) (SNVA038).

LM2590HV

SNVS084C – DECEMBER 2001 – REVISED JULY 2016

www.ti.com

9.2.3 Application Curves

For continuous mode operation

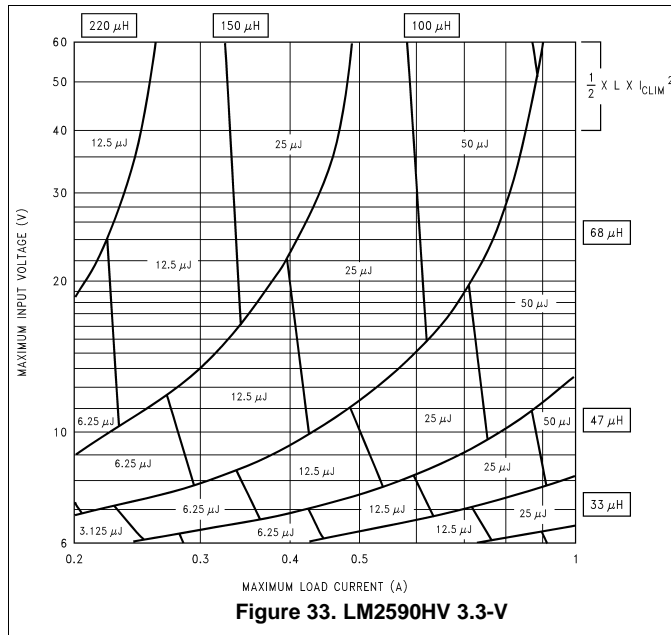

Figure 33. LM2590HV 3.3-V

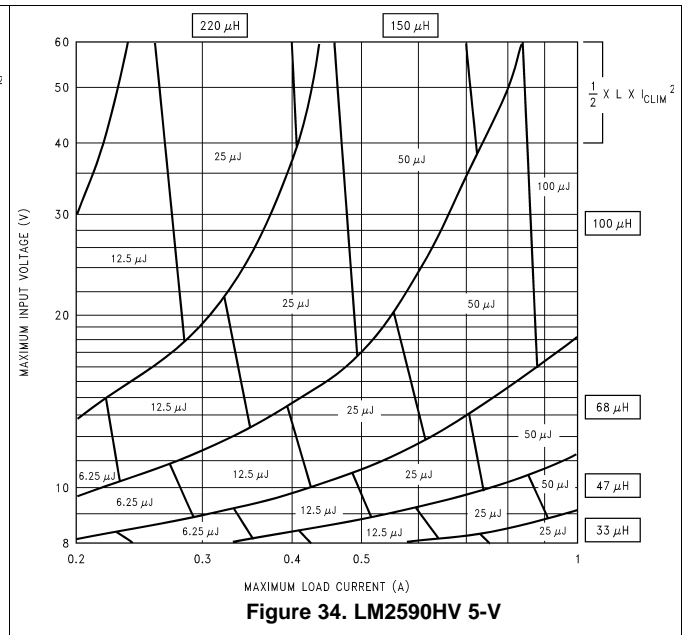

Figure 34. LM2590HV 5-V

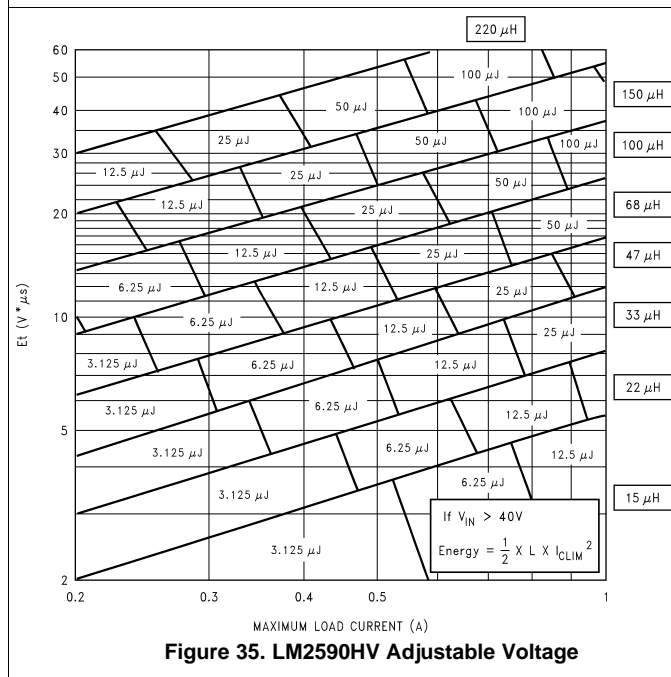

Figure 35. LM2590HV Adjustable Voltage

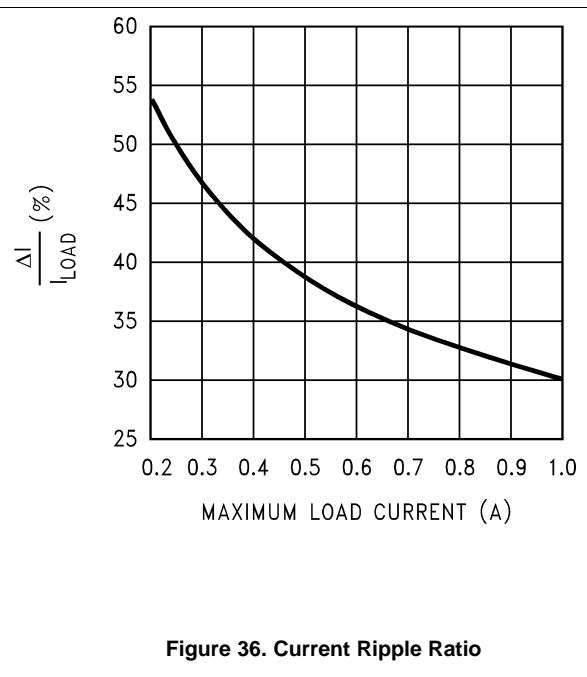

Figure 36. Current Ripple Ratio

10 Power Supply Recommendations

The LM2590HV is designed to operate from an input voltage supply up to 60 V. This input supply must be well regulated and able to withstand maximum input current and maintain a stable voltage.

11 Layout

11.1 Layout Guidelines

As in any switching regulator, layout is very important. Rapidly switching currents associated with wiring inductance can generate voltage transients which can cause problems. For minimal inductance and ground loops, with reference to [Test Circuits](#), the wires indicated by heavy lines must be wide printed circuit traces and must be kept as short as possible. For best results, external components must be located as close to the switcher IC as possible using ground plane construction or single point grounding.

If open-core inductors are used, special care must be taken as to the location and positioning of this type of inductor. Allowing the inductor flux to intersect sensitive feedback, IC groundpath and C_{OUT} wiring can cause problems.

When using the adjustable version, take special care as to the location of the feedback resistors and the associated wiring. Physically locate both resistors near the IC, and route the wiring away from the inductor, especially an open-core type of inductor.

11.2 Layout Examples

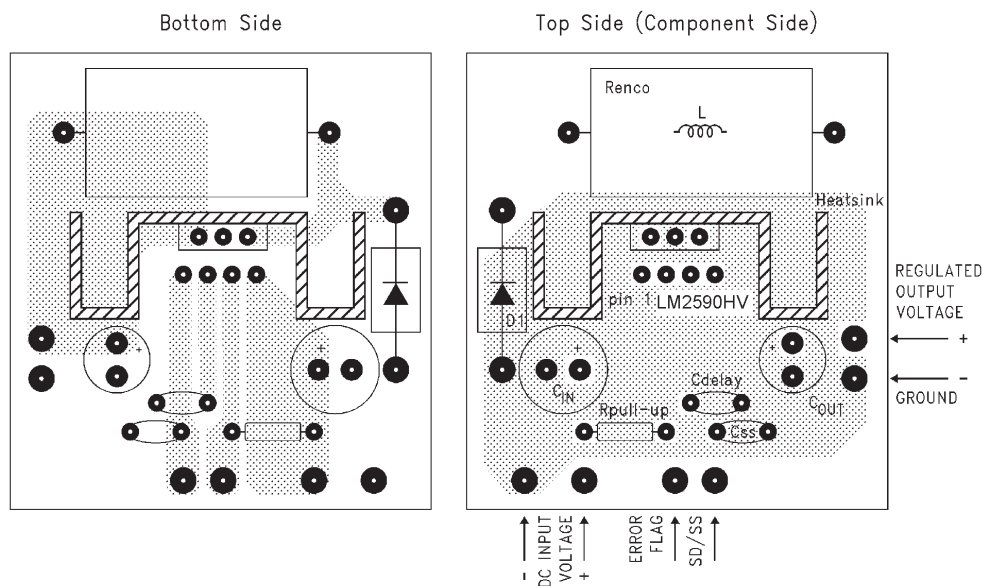

C_{IN} = 470- μ F, 50-V aluminum electrolytic Panasonic *HFQ Series*
 C_{OUT} = 330- μ F, 35-V aluminum electrolytic Panasonic *HFQ Series*
 $D1$ = 5-A, 40-V Schottky rectifier, 1N5825
 $L1$ = 47- μ H, L39 Renco through-hole
 $R_{PULL\ UP}$ = 10k
 C_{DELAY} = 0.1 μ F
 $C_{SD/SS}$ = 0.1 μ F
 Thermalloy heat sink #7020

Figure 37. Typical Through-Hole PCB Layout, Fixed Output (1x Size), Double-Sided

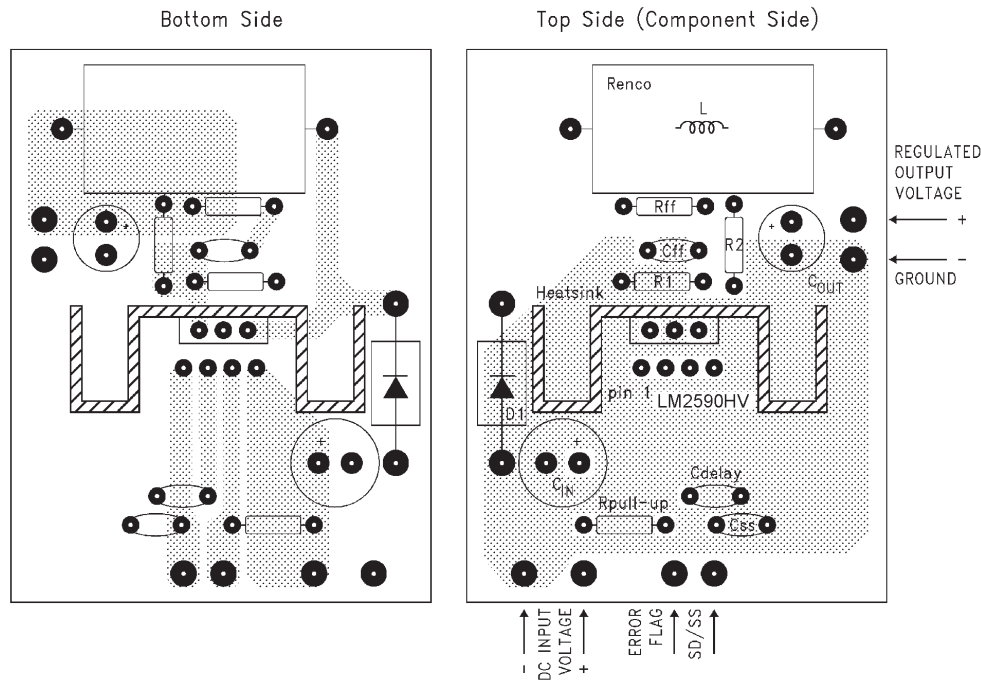
Layout Examples (continued)

- C_{IN} = 470- μ F, 50-V aluminum electrolytic Panasonic *HFQ Series*
- C_{OUT} = 220- μ F, 35-V aluminum electrolytic Panasonic *HFQ Series*
- D1 = 5-A, 40-V Schottky Rectifier, 1N5825
- L1 = 47- μ H, L39 Renco, through-hole
- R_1 = 1 k Ω , 1%
- R_2 = Use formula in [Detailed Design Procedure](#)
- C_{FF} = See [Feedforward Capacitor, \$C_{FF}\$](#)
- R_{FF} = See [Feedforward Capacitor, \$C_{FF}\$](#)
- $R_{PULL\ UP}$ = 10k
- C_{DELAY} = 0.1 μ F
- $C_{SD/SS}$ = 0.1 μ F
- Thermalloy heat sink #7020

Figure 38. Typical Through-Hole PCB Layout, Adjustable Output (1x Size), Double-Sided
11.3 Thermal Considerations

The LM2590HV is available in two packages, a 5-pin TO-220 (T) and a 5-pin surface-mount TO-263 (S). The TO-220 package needs a heat sink under most conditions. The size of the heatsink depends on the input voltage, the output voltage, the load current and the ambient temperature. Higher ambient temperatures require more heat sinking. The TO-263 surface-mount package tab is designed to be soldered to the copper on a printed circuit board. The copper and the board are the heat sink for this package and the other heat producing components, such as the catch diode and inductor. The PCB copper area that the package is soldered to must be at least 0.4 in², and ideally must have 2 or more square inches of 2 oz. (0.0028) in. copper. Additional copper area improves the thermal characteristics, but with copper areas greater than approximately 6 in², only small improvements in heat dissipation are realized. If further thermal improvements are needed, double-sided, multilayer PC board with large copper areas or airflow are recommended. The curves shown in [Figure 39](#) show the LM2590HV (TO-263 package) junction temperature rise above ambient temperature with a 2-A load for various input and output voltages. This data was taken with the circuit operating as a buck switching regulator with all components mounted on a PCB to simulate the junction temperature under actual operating conditions. This curve can be used for a quick check for the approximate junction temperature for various conditions, but be aware that there are many factors that can affect the junction temperature. When load currents higher than 2 A

Thermal Considerations (continued)

are used, double-sided or multilayer boards with large copper areas or airflow might be needed, especially for high ambient temperatures and high output voltages. For the best thermal performance, wide copper traces and generous amounts of printed circuit board copper must be used in the board layout. One exception to this is the output (switch) pin, which must not have large areas of copper. Large areas of copper provide the best transfer of heat (lower thermal resistance) to the surrounding air, and moving air lowers the thermal resistance even further. Package thermal resistance and junction temperature rise numbers are all approximate, and there are many factors that will affect these numbers. Some of these factors include board size, shape, thickness, position, location, and even board temperature. Other factors are, trace width, total printed circuit copper area, copper thickness, single- or double-sided, multilayer board and the amount of solder on the board. The effectiveness of the PCB to dissipate heat also depends on the size, quantity and spacing of other components on the board, as well as whether the surrounding air is still or moving. Furthermore, some of these components such as the catch diode will add heat to the PCB and the heat can vary as the input voltage changes. For the inductor, depending on the physical size, type of core material and the DC resistance, it could either act as a heat sink taking heat away from the board, or it could add heat to the board.

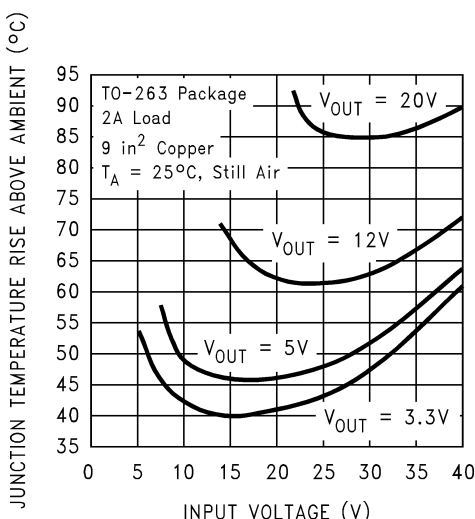

Figure 39. Junction Temperature Rise, TO-263

12 Device and Documentation Support

12.1 Documentation Support

12.1.1 Related Documentation

For related documentation see the following:

[AN-1197 Selecting Inductors for Buck Converters](#) (SNVA038)

12.2 Receiving Notification of Documentation Updates

To receive notification of documentation updates, navigate to the device product folder on ti.com. In the upper right corner, click on *Alert me* to register and receive a weekly digest of any product information that has changed. For change details, review the revision history included in any revised document.

12.3 Community Resources

The following links connect to TI community resources. Linked contents are provided "AS IS" by the respective contributors. They do not constitute TI specifications and do not necessarily reflect TI's views; see TI's [Terms of Use](#).

TI E2E™ Online Community *TI's Engineer-to-Engineer (E2E) Community*. Created to foster collaboration among engineers. At e2e.ti.com, you can ask questions, share knowledge, explore ideas and help solve problems with fellow engineers.

Design Support *TI's Design Support* Quickly find helpful E2E forums along with design support tools and contact information for technical support.

12.4 Trademarks

E2E is a trademark of Texas Instruments.

All other trademarks are the property of their respective owners.

12.5 Electrostatic Discharge Caution



These devices have limited built-in ESD protection. The leads should be shorted together or the device placed in conductive foam during storage or handling to prevent electrostatic damage to the MOS gates.

12.6 Glossary

[SLYZ022](#) — *TI Glossary*.

This glossary lists and explains terms, acronyms, and definitions.

13 Mechanical, Packaging, and Orderable Information

The following pages include mechanical, packaging, and orderable information. This information is the most current data available for the designated devices. This data is subject to change without notice and revision of this document. For browser-based versions of this data sheet, refer to the left-hand navigation.

PACKAGING INFORMATION

Orderable Device	Status (1)	Package Type	Package Drawing	Pins	Package Qty	Eco Plan (2)	Lead/Ball Finish (6)	MSL Peak Temp (3)	Op Temp (°C)	Device Marking (4/5)	Samples
LM2590HVS-3.3/NOPB	ACTIVE	DDPAK/ TO-263	KTW	7	45	Pb-Free (RoHS Exempt)	CU SN	Level-3-245C-168 HR	-40 to 125	LM2590HVS -3.3 P+	Samples
LM2590HVS-5.0/NOPB	ACTIVE	DDPAK/ TO-263	KTW	7	45	Pb-Free (RoHS Exempt)	CU SN	Level-3-245C-168 HR	-40 to 125	LM2590HVS -5.0 P+	Samples
LM2590HVS-ADJ/NOPB	ACTIVE	DDPAK/ TO-263	KTW	7	45	Pb-Free (RoHS Exempt)	CU SN	Level-3-245C-168 HR	-40 to 125	LM2590HVS -ADJ P+	Samples
LM2590HVSX-3.3/NOPB	ACTIVE	DDPAK/ TO-263	KTW	7	500	Pb-Free (RoHS Exempt)	CU SN	Level-3-245C-168 HR	-40 to 125	LM2590HVS -3.3 P+	Samples
LM2590HVSX-5.0/NOPB	ACTIVE	DDPAK/ TO-263	KTW	7	500	Pb-Free (RoHS Exempt)	CU SN	Level-3-245C-168 HR	-40 to 125	LM2590HVS -5.0 P+	Samples
LM2590HVSX-ADJ/NOPB	ACTIVE	DDPAK/ TO-263	KTW	7	500	Pb-Free (RoHS Exempt)	CU SN	Level-3-245C-168 HR	-40 to 125	LM2590HVS -ADJ P+	Samples
LM2590HVT-5.0/NOPB	ACTIVE	TO-220	NDZ	7	45	Green (RoHS & no Sb/Br)	CU SN	Level-1-NA-UNLIM	-40 to 125	LM2590HVT -5.0 P+	Samples
LM2590HVT-ADJ/NOPB	ACTIVE	TO-220	NDZ	7	45	Green (RoHS & no Sb/Br)	CU SN	Level-1-NA-UNLIM	-40 to 125	LM2590HVT -ADJ P+	Samples

(1) The marketing status values are defined as follows:

ACTIVE: Product device recommended for new designs.

LIFEBUY: TI has announced that the device will be discontinued, and a lifetime-buy period is in effect.

NRND: Not recommended for new designs. Device is in production to support existing customers, but TI does not recommend using this part in a new design.

PREVIEW: Device has been announced but is not in production. Samples may or may not be available.

OBSOLETE: TI has discontinued the production of the device.

(2) Eco Plan - The planned eco-friendly classification: Pb-Free (RoHS), Pb-Free (RoHS Exempt), or Green (RoHS & no Sb/Br) - please check <http://www.ti.com/productcontent> for the latest availability information and additional product content details.

TBD: The Pb-Free/Green conversion plan has not been defined.

Pb-Free (RoHS): TI's terms "Lead-Free" or "Pb-Free" mean semiconductor products that are compatible with the current RoHS requirements for all 6 substances, including the requirement that lead not exceed 0.1% by weight in homogeneous materials. Where designed to be soldered at high temperatures, TI Pb-Free products are suitable for use in specified lead-free processes.

Pb-Free (RoHS Exempt): This component has a RoHS exemption for either 1) lead-based flip-chip solder bumps used between the die and package, or 2) lead-based die adhesive used between the die and leadframe. The component is otherwise considered Pb-Free (RoHS compatible) as defined above.

Green (RoHS & no Sb/Br): TI defines "Green" to mean Pb-Free (RoHS compatible), and free of Bromine (Br) and Antimony (Sb) based flame retardants (Br or Sb do not exceed 0.1% by weight in homogeneous material)

(3) MSL, Peak Temp. - The Moisture Sensitivity Level rating according to the JEDEC industry standard classifications, and peak solder temperature.

(4) There may be additional marking, which relates to the logo, the lot trace code information, or the environmental category on the device.

(5) Multiple Device Markings will be inside parentheses. Only one Device Marking contained in parentheses and separated by a "~" will appear on a device. If a line is indented then it is a continuation of the previous line and the two combined represent the entire Device Marking for that device.

(6) Lead/Ball Finish - Orderable Devices may have multiple material finish options. Finish options are separated by a vertical ruled line. Lead/Ball Finish values may wrap to two lines if the finish value exceeds the maximum column width.

Important Information and Disclaimer:The information provided on this page represents TI's knowledge and belief as of the date that it is provided. TI bases its knowledge and belief on information provided by third parties, and makes no representation or warranty as to the accuracy of such information. Efforts are underway to better integrate information from third parties. TI has taken and continues to take reasonable steps to provide representative and accurate information but may not have conducted destructive testing or chemical analysis on incoming materials and chemicals. TI and TI suppliers consider certain information to be proprietary, and thus CAS numbers and other limited information may not be available for release.

In no event shall TI's liability arising out of such information exceed the total purchase price of the TI part(s) at issue in this document sold by TI to Customer on an annual basis.

TAPE AND REEL INFORMATION

QUADRANT ASSIGNMENTS FOR PIN 1 ORIENTATION IN TAPE

*All dimensions are nominal

Device	Package Type	Package Drawing	Pins	SPQ	Reel Diameter (mm)	Reel Width W1 (mm)	A0 (mm)	B0 (mm)	K0 (mm)	P1 (mm)	W (mm)	Pin1 Quadrant
LM2590HVSX-3.3/NOPB	DDPAK/ TO-263	KTW	7	500	330.0	24.4	10.75	14.85	5.0	16.0	24.0	Q2
LM2590HVSX-5.0/NOPB	DDPAK/ TO-263	KTW	7	500	330.0	24.4	10.75	14.85	5.0	16.0	24.0	Q2
LM2590HVSX-ADJ/NOPB	DDPAK/ TO-263	KTW	7	500	330.0	24.4	10.75	14.85	5.0	16.0	24.0	Q2

TAPE AND REEL BOX DIMENSIONS



*All dimensions are nominal

Device	Package Type	Package Drawing	Pins	SPQ	Length (mm)	Width (mm)	Height (mm)
LM2590HVSX-3.3/NOPB	DDPAK/TO-263	KTW	7	500	367.0	367.0	45.0
LM2590HVSX-5.0/NOPB	DDPAK/TO-263	KTW	7	500	367.0	367.0	45.0
LM2590HVSX-ADJ/NOPB	DDPAK/TO-263	KTW	7	500	367.0	367.0	45.0

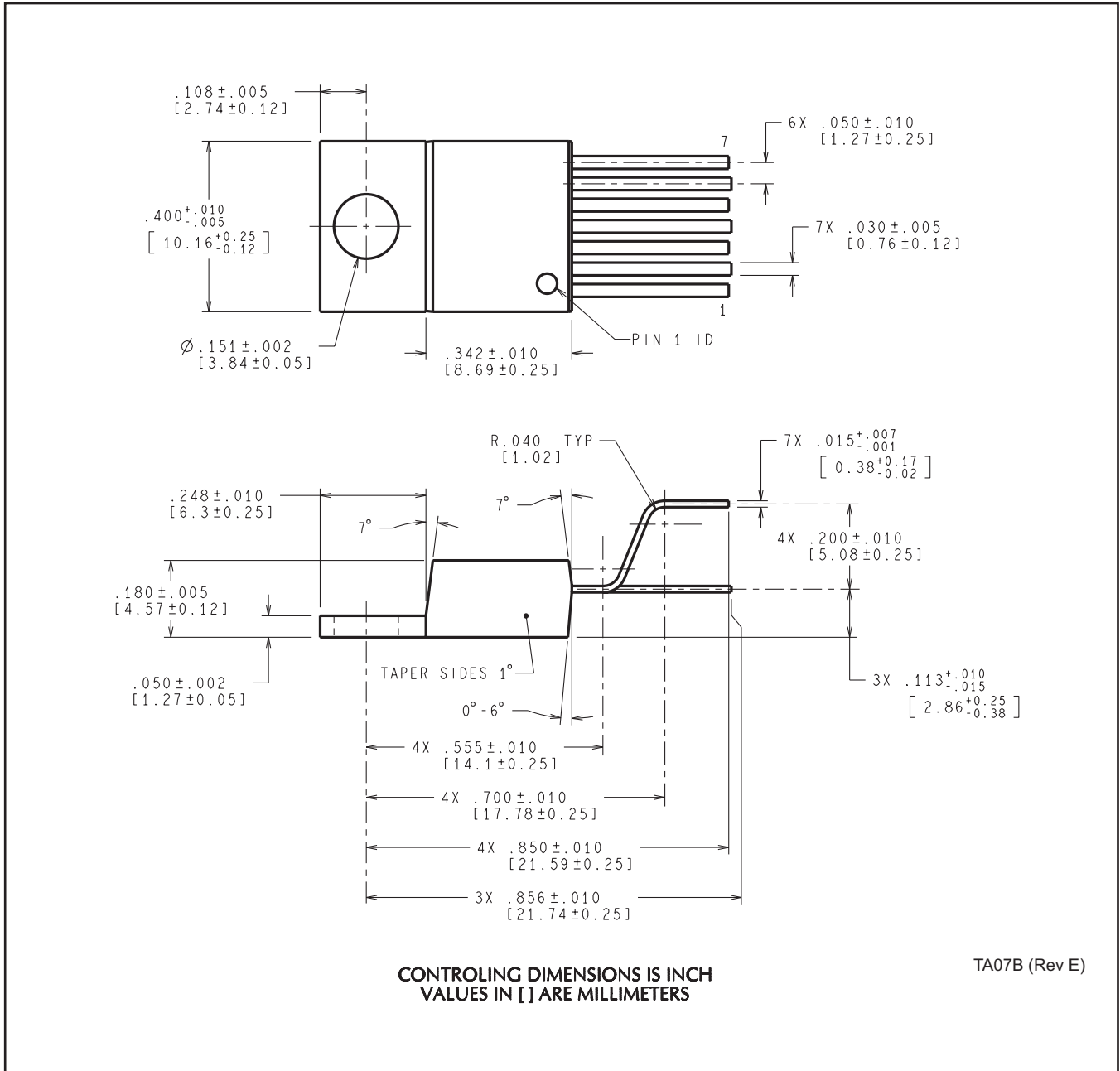
NDZ0007B

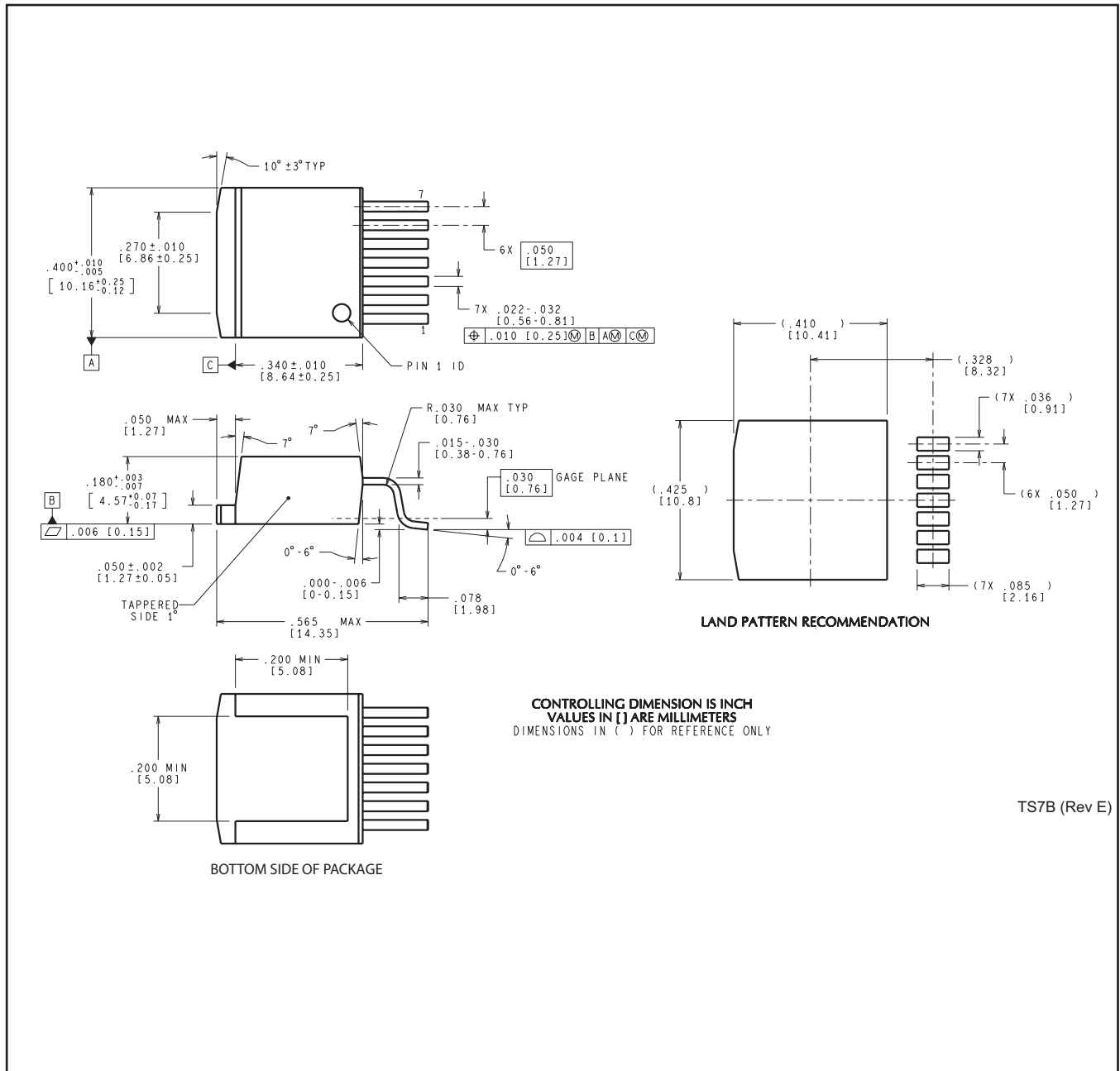

KTW0007B



TS7B (Rev E)

IMPORTANT NOTICE

Texas Instruments Incorporated (TI) reserves the right to make corrections, enhancements, improvements and other changes to its semiconductor products and services per JESD46, latest issue, and to discontinue any product or service per JESD48, latest issue. Buyers should obtain the latest relevant information before placing orders and should verify that such information is current and complete.

TI's published terms of sale for semiconductor products (<http://www.ti.com/sc/docs/stdterms.htm>) apply to the sale of packaged integrated circuit products that TI has qualified and released to market. Additional terms may apply to the use or sale of other types of TI products and services.

Reproduction of significant portions of TI information in TI data sheets is permissible only if reproduction is without alteration and is accompanied by all associated warranties, conditions, limitations, and notices. TI is not responsible or liable for such reproduced documentation. Information of third parties may be subject to additional restrictions. Resale of TI products or services with statements different from or beyond the parameters stated by TI for that product or service voids all express and any implied warranties for the associated TI product or service and is an unfair and deceptive business practice. TI is not responsible or liable for any such statements.

Buyers and others who are developing systems that incorporate TI products (collectively, "Designers") understand and agree that Designers remain responsible for using their independent analysis, evaluation and judgment in designing their applications and that Designers have full and exclusive responsibility to assure the safety of Designers' applications and compliance of their applications (and of all TI products used in or for Designers' applications) with all applicable regulations, laws and other applicable requirements. Designer represents that, with respect to their applications, Designer has all the necessary expertise to create and implement safeguards that (1) anticipate dangerous consequences of failures, (2) monitor failures and their consequences, and (3) lessen the likelihood of failures that might cause harm and take appropriate actions. Designer agrees that prior to using or distributing any applications that include TI products, Designer will thoroughly test such applications and the functionality of such TI products as used in such applications.

TI's provision of technical, application or other design advice, quality characterization, reliability data or other services or information, including, but not limited to, reference designs and materials relating to evaluation modules, (collectively, "TI Resources") are intended to assist designers who are developing applications that incorporate TI products; by downloading, accessing or using TI Resources in any way, Designer (individually or, if Designer is acting on behalf of a company, Designer's company) agrees to use any particular TI Resource solely for this purpose and subject to the terms of this Notice.

TI's provision of TI Resources does not expand or otherwise alter TI's applicable published warranties or warranty disclaimers for TI products, and no additional obligations or liabilities arise from TI providing such TI Resources. TI reserves the right to make corrections, enhancements, improvements and other changes to its TI Resources. TI has not conducted any testing other than that specifically described in the published documentation for a particular TI Resource.

Designer is authorized to use, copy and modify any individual TI Resource only in connection with the development of applications that include the TI product(s) identified in such TI Resource. NO OTHER LICENSE, EXPRESS OR IMPLIED, BY ESTOPPEL OR OTHERWISE TO ANY OTHER TI INTELLECTUAL PROPERTY RIGHT, AND NO LICENSE TO ANY TECHNOLOGY OR INTELLECTUAL PROPERTY RIGHT OF TI OR ANY THIRD PARTY IS GRANTED HEREIN, including but not limited to any patent right, copyright, mask work right, or other intellectual property right relating to any combination, machine, or process in which TI products or services are used. Information regarding or referencing third-party products or services does not constitute a license to use such products or services, or a warranty or endorsement thereof. Use of TI Resources may require a license from a third party under the patents or other intellectual property of the third party, or a license from TI under the patents or other intellectual property of TI.

TI RESOURCES ARE PROVIDED "AS IS" AND WITH ALL FAULTS. TI DISCLAIMS ALL OTHER WARRANTIES OR REPRESENTATIONS, EXPRESS OR IMPLIED, REGARDING RESOURCES OR USE THEREOF, INCLUDING BUT NOT LIMITED TO ACCURACY OR COMPLETENESS, TITLE, ANY EPIDEMIC FAILURE WARRANTY AND ANY IMPLIED WARRANTIES OF MERCHANTABILITY, FITNESS FOR A PARTICULAR PURPOSE, AND NON-INFRINGEMENT OF ANY THIRD PARTY INTELLECTUAL PROPERTY RIGHTS. TI SHALL NOT BE LIABLE FOR AND SHALL NOT DEFEND OR INDEMNIFY DESIGNER AGAINST ANY CLAIM, INCLUDING BUT NOT LIMITED TO ANY INFRINGEMENT CLAIM THAT RELATES TO OR IS BASED ON ANY COMBINATION OF PRODUCTS EVEN IF DESCRIBED IN TI RESOURCES OR OTHERWISE. IN NO EVENT SHALL TI BE LIABLE FOR ANY ACTUAL, DIRECT, SPECIAL, COLLATERAL, INDIRECT, PUNITIVE, INCIDENTAL, CONSEQUENTIAL OR EXEMPLARY DAMAGES IN CONNECTION WITH OR ARISING OUT OF TI RESOURCES OR USE THEREOF, AND REGARDLESS OF WHETHER TI HAS BEEN ADVISED OF THE POSSIBILITY OF SUCH DAMAGES.

Unless TI has explicitly designated an individual product as meeting the requirements of a particular industry standard (e.g., ISO/TS 16949 and ISO 26262), TI is not responsible for any failure to meet such industry standard requirements.

Where TI specifically promotes products as facilitating functional safety or as compliant with industry functional safety standards, such products are intended to help enable customers to design and create their own applications that meet applicable functional safety standards and requirements. Using products in an application does not by itself establish any safety features in the application. Designers must ensure compliance with safety-related requirements and standards applicable to their applications. Designer may not use any TI products in life-critical medical equipment unless authorized officers of the parties have executed a special contract specifically governing such use. Life-critical medical equipment is medical equipment where failure of such equipment would cause serious bodily injury or death (e.g., life support, pacemakers, defibrillators, heart pumps, neurostimulators, and implantables). Such equipment includes, without limitation, all medical devices identified by the U.S. Food and Drug Administration as Class III devices and equivalent classifications outside the U.S.

TI may expressly designate certain products as completing a particular qualification (e.g., Q100, Military Grade, or Enhanced Product). Designers agree that it has the necessary expertise to select the product with the appropriate qualification designation for their applications and that proper product selection is at Designers' own risk. Designers are solely responsible for compliance with all legal and regulatory requirements in connection with such selection.

Designer will fully indemnify TI and its representatives against any damages, costs, losses, and/or liabilities arising out of Designer's non-compliance with the terms and provisions of this Notice.

Looking for pricing, stock, or lifecycle information?

Click below to explore more details on WIN SOURCE:

 [View LM2590HVS-3.3/NOPB on WIN SOURCE](#)

 [Texas Instruments](#) Information

Optimize Your Supply Chain with WIN SOURCE Solutions

-  Global Sourcing Solution
-  Obsolete Management
-  Cost Control Management
-  Shortage Management
-  Alternative Solution
-  Excess Inventory Management