



**THE DATASHEET OF
SCAN92LV090VEHX/NOPB**



SCAN92LV090 9 Channel Bus LVDS Transceiver w/ Boundary SCAN

Check for Samples: [SCAN92LV090](#)

FEATURES

- IEEE 1149.1 (JTAG) Compliant
- Bus LVDS Signaling
- Low Power CMOS Design
- High Signaling Rate Capability (Above 100 Mbps)
- 0.1V to 2.3V Common Mode Range for $V_{ID} = 200\text{mV}$
- $\pm 100\text{ mV}$ Receiver Sensitivity
- Supports Open and Terminated Failsafe on Port Pins
- 3.3V Operation
- Glitch Free Power Up/Down (Driver & Receiver Disabled)
- Light Bus Loading (5 pF Typical) per Bus LVDS Load
- Designed for Double Termination Applications
- Balanced Output Impedance
- Product Offered in 64 Pin LQFP Package and NFBGA Package
- High Impedance Bus Pins on Power Off ($V_{CC} = 0\text{V}$)

DESCRIPTION

The SCAN92LV090A is one in a series of Bus LVDS transceivers designed specifically for the high speed, low power proprietary backplane or cable interfaces. The device operates from a single 3.3V power supply and includes nine differential line drivers and nine receivers. To minimize bus loading, the driver outputs and receiver inputs are internally connected. The separate I/O of the logic side allows for loop back support. The device also features a flow through pin out which allows easy PCB routing for short stubs between its pins and the connector.

The driver translates 3V TTL levels (single-ended) to differential Bus LVDS (BLVDS) output levels. This allows for high speed operation, while consuming minimal power with reduced EMI. In addition, the differential signaling provides common mode noise rejection of $\pm 1\text{V}$.

The receiver threshold is less than $\pm 100\text{ mV}$ over a $\pm 1\text{V}$ common mode range and translates the differential Bus LVDS to standard (TTL/CMOS) levels.

This device is compliant with IEEE 1149.1 Standard Test Access Port and Boundary Scan Architecture with the incorporation of the defined boundary-scan test logic and test access port consisting of Test Data Input (TDI), Test Data Out (TDO), Test Mode Select (TMS), Test Clock (TCK), and the optional Test Reset (TRST).

SIMPLIFIED FUNCTIONAL DIAGRAM

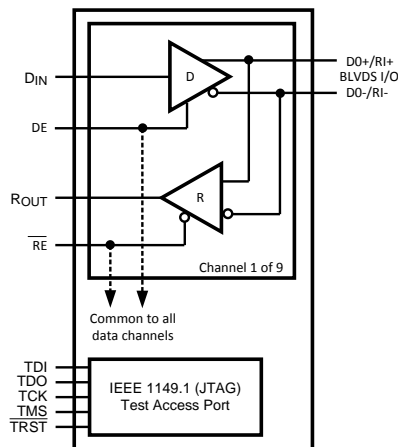

Figure 1.



Please be aware that an important notice concerning availability, standard warranty, and use in critical applications of Texas Instruments semiconductor products and disclaimers thereto appears at the end of this data sheet.

All trademarks are the property of their respective owners.

CONNECTION DIAGRAM

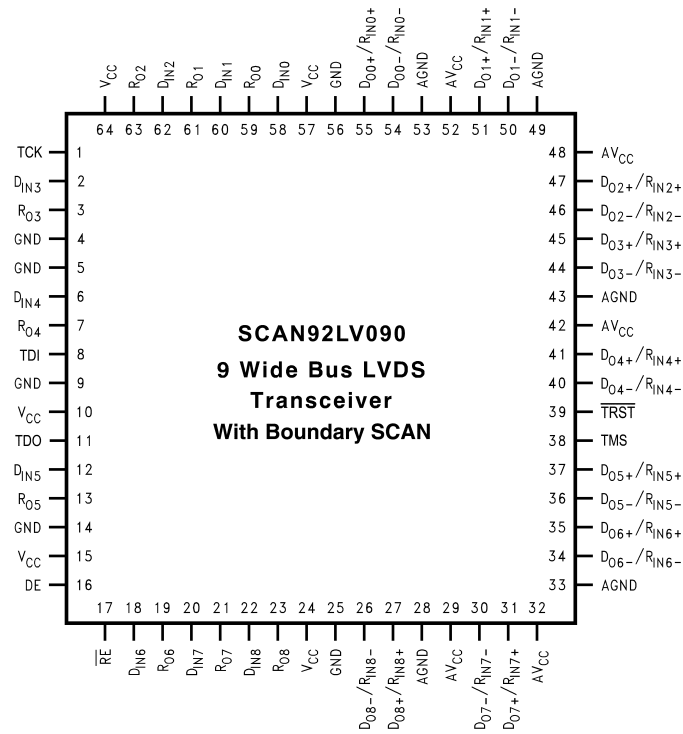

Figure 2. Top View Package Number PM0064

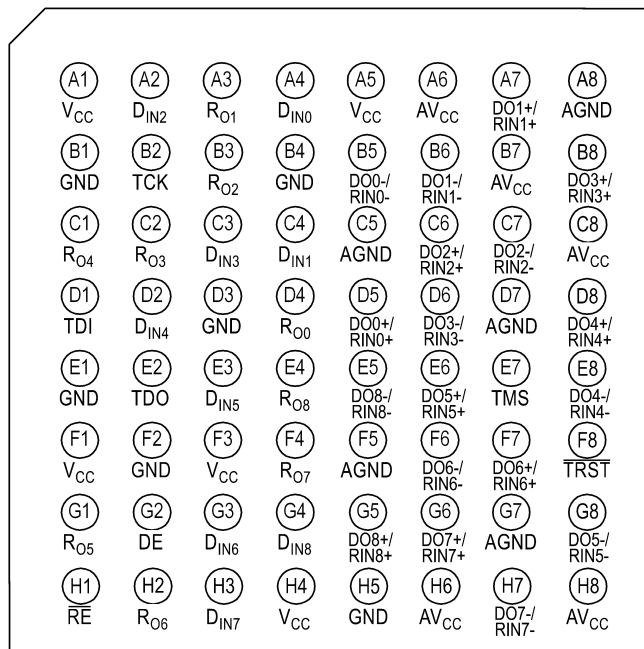

Figure 3. Top View Package Number NZC0064A

PINOUT DESCRIPTION

Pin Name	LQFP Pin #	NFBGA Pin #	Input/Output	Descriptions
DO+/RI+	27, 31, 35, 37, 41, 45, 47, 51, 55	A7, B8, C6, D5, D8, E6, F7, G5, G6	I/O	True Bus LVDS Driver Outputs and Receiver Inputs.
DO-/RI-	26, 30, 34, 36, 40, 44, 46, 50, 54	B5, B6, C7, D6, E5, E8, F6, G8, H7	I/O	Complimentary Bus LVDS Driver Outputs and Receiver Inputs.
D _{IN}	2, 6, 12, 18, 20, 22, 58, 60, 62	A2, A4, C3, C4, D2, E3, G3, G4, H3	I	TTL Driver Input.
RO	3, 7, 13, 19, 21, 23, 59, 61, 63	A3, B3, C1, C2, D4, E4, F4, G1, H2	O	TTL Receiver Output.
\overline{RE}	17	H1	I	Receiver Enable TTL Input (Active Low).
DE	16	G2	I	Driver Enable TTL Input (Active High).
GND	4, 5, 9, 14, 25, 56	B1, B4, D3, E1, F2, H5	Power	Ground for digital circuitry (must connect to GND on PC board). These pins connected internally.
V _{CC}	10, 15, 24, 57, 64	A1, A5, F1, F3, H4	Power	V _{CC} for digital circuitry (must connect to V _{CC} on PC board). These pins connected internally.
AGND	28, 33, 43, 49, 53	A8, C5, D7, F5, G7	Power	Ground for analog circuitry (must connect to GND on PC board). These pins connected internally.
AV _{CC}	29, 32, 42, 48, 52	A6, B7, C8, H6, H8	Power	Analog V _{CC} (must connect to V _{CC} on PC board). These pins connected internally.
\overline{TRST}	39	F8	I	Test Reset Input to support IEEE 1149.1 (Active Low)
TMS	38	E7	I	Test Mode Select Input to support IEEE 1149.1
TCK	1	B2	I	Test Clock Input to support IEEE 1149.1
TDI	8	D1	I	Test Data Input to support IEEE 1149.1
TDO	11	E2	O	Test Data Output to support IEEE 1149.1



These devices have limited built-in ESD protection. The leads should be shorted together or the device placed in conductive foam during storage or handling to prevent electrostatic damage to the MOS gates.

ABSOLUTE MAXIMUM RATINGS ⁽¹⁾⁽²⁾⁽³⁾

Supply Voltage (V _{CC})	4.0V	
Enable Input Voltage (DE, \overline{RE})	-0.3V to (V _{CC} +0.3V)	
Driver Input Voltage (D _{IN})	-0.3V to (V _{CC} +0.3V)	
Receiver Output Voltage (R _{OUT})	-0.3V to (V _{CC} +0.3V)	
Bus Pin Voltage (DO/RI \pm)	-0.3V to +3.9V	
ESD (HBM 1.5 k Ω , 100 pF)	>4.5 kV	
Driver Short Circuit Duration	momentary	
Receiver Short Circuit Duration	momentary	
Maximum Package Power Dissipation at 25°C	LQFP	1.74 W
	Derate LQFP Package	13.9 mW/°C
	θ_{ja}	71.7°C/W
	θ_{jc}	10.9°C/W
Junction Temperature	+150°C	
Storage Temperature Range	-65°C to +150°C	
Lead Temperature (Soldering, 4 sec.)	260°C	

- (1) Absolute Maximum Ratings are those values beyond which the safety of the device cannot be ensured. They are not meant to imply that the devices should be operated at these limits. The table of "Electrical Characteristics" provides conditions for actual device operation.
- (2) All currents into device pins are positive; all currents out of device pins are negative. All voltages are referenced to ground unless otherwise specified except V_{OD}, ΔV_{OD} and V_{ID}.
- (3) If Military/Aerospace specified devices are required, please contact the Texas Instruments Sales Office/ Distributors for availability and specifications.

RECOMMENDED OPERATING CONDITIONS

		Min	Max	Units
Supply Voltage (V_{CC})		3.0	3.6	V
Receiver Input Voltage		0.0	2.4	V
Operating Free Air Temperature		-40	+85	°C
Maximum Input Edge Rate	(20% to 80%) ⁽¹⁾			$\Delta t/\Delta V$
	Data		1.0	ns/V
	Control		3.0	ns/V

- (1) Generator waveforms for all tests unless otherwise specified: $f = 25$ MHz, $Z_O = 50\Omega$, $t_r, t_f < 1.0$ ns (0%–100%). To ensure fastest propagation delay and minimum skew, data input edge rates should be equal to or faster than 1ns/V; control signals equal to or faster than 3ns/V. In general, the faster the input edge rate, the better the AC performance.

DC ELECTRICAL CHARACTERISTICS

Over recommended operating supply voltage and temperature ranges unless otherwise specified ⁽¹⁾⁽²⁾

Symbol	Parameter	Conditions	Pin	Min	Typ	Max	Units
V_{OD}	Output Differential Voltage	$R_L = 27\Omega$, See Figure 4	DO+/RI+, DO-/RI-	240	300	460	mV
ΔV_{OD}	V_{OD} Magnitude Change					27	mV
V_{OS}	Offset Voltage			1.1	1.3	1.5	V
ΔV_{OS}	Offset Magnitude Change				5	10	mV
V_{OH}	Driver Output High Voltage ⁽³⁾	$R_L = 27\Omega$			1.4	1.65	V
V_{OL}	Driver Output Low Voltage ⁽³⁾	$R_L = 27\Omega$		0.95	1.1		V
I_{OSD}	Output Short Circuit Current ⁽⁴⁾	$V_{OD} = 0V$, $DE = V_{CC}$, Driver outputs shorted together			36	65	mA
V_{OH}	Voltage Output High ⁽⁵⁾	$V_{ID} = +300$ mV		R_{OUT}	$V_{CC}-0.2$		
		Inputs Open	$V_{CC}-0.2$				V
		Inputs Terminated, $R_L = 27\Omega$	$V_{CC}-0.2$				V
V_{OL}	Voltage Output Low	$I_{OL} = 2.0$ mA, $V_{ID} = -300$ mV			0.05	0.075	V
I_{OD}	Receiver Output Dynamic Current ⁽⁴⁾	$V_{ID} = 300$ mV, $V_{OUT} = V_{CC}-1.0V$		-110	75		mA
		$V_{ID} = -300$ mV, $V_{OUT} = 1.0V$			75	110	mA
V_{TH}	Input Threshold High	$DE = 0V$, $V_{CM} = 1.5V$	DO+/RI+, DO-/RI-			+100	mV
V_{TL}	Input Threshold Low			-100		mV	
V_{CMR}	Receiver Common Mode Range			$ V_{ID} /2$		2.4 - $ V_{ID} /2$	V
I_{IN}	Input Current	$DE = 0V$, $\overline{RE} = 2.4V$, $V_{IN} = +2.4V$ or $0V$		-25	± 1	+25	μA
		$V_{CC} = 0V$, $V_{IN} = +2.4V$ or $0V$		-20	± 1	+20	μA
V_{IH}	Minimum Input High Voltage		$\overline{D_{IN}}$, DE , \overline{RE} , TCK , \overline{TRST} , TMS , TDI	2.0		V_{CC}	V
V_{IL}	Maximum Input Low Voltage			GND		0.8	V
I_{IH}	Input High Current	$V_{IN} = V_{CC}$ or $2.4V$	$\overline{D_{IN}}$, DE , \overline{RE}	-20	± 10	+20	μA
I_{IL}	Input Low Current	$V_{IN} = GND$ or $0.4V$		-20	± 10	+20	μA
V_{CL}	Input Diode Clamp Voltage	$I_{CLAMP} = -18$ mA		-1.5	-0.8		V
I_{IH}	Input High Current	$V_{IN} = V_{CC}$	\overline{TDI} , \overline{TMS} , \overline{TCK} , \overline{TRST}	-20		+20	μA
I_{ILR}	Input Low Current	$V_{IN} = GND$, $V_{CC} = 3.6V$	\overline{TDI} , \overline{TMS} , \overline{TRST}	-25		-115	μA

- (1) All currents into device pins are positive; all currents out of device pins are negative. All voltages are referenced to ground unless otherwise specified except V_{OD} , ΔV_{OD} and V_{ID} .
- (2) All typicals are given for $V_{CC} = +3.3V$ and $T_A = +25^\circ C$, unless otherwise stated.
- (3) The SCAN92LV090 functions within datasheet specification when a resistive load is applied to the driver outputs.
- (4) Only one output at a time should be shorted, do not exceed maximum package power dissipation capacity.
- (5) V_{OH} failsafe terminated test performed with 27Ω connected between RI+ and RI- inputs. No external voltage is applied.

DC ELECTRICAL CHARACTERISTICS (continued)

 Over recommended operating supply voltage and temperature ranges unless otherwise specified ⁽¹⁾⁽²⁾

Symbol	Parameter	Conditions	Pin	Min	Typ	Max	Units
I _{IL}	Input Low Current	V _{IN} = GND	TCK	-20		+20	μA
I _{CCD}	Power Supply Current Drivers Enabled, Receivers Disabled	No Load, DE = \overline{RE} = V _{CC} , DIN = V _{CC} or GND	V _{CC}		50	80	mA
I _{CCR}	Power Supply Current Drivers Disabled, Receivers Enabled	DE = \overline{RE} = 0V, V _{ID} = ±300mV			50	80	mA
I _{CCZ}	Power Supply Current, Drivers and Receivers tri-state	DE = 0V; \overline{RE} = V _{CC} , DIN = V _{CC} or GND			50	80	mA
I _{CC}	Power Supply Current, Drivers and Receivers Enabled	DE = V _{CC} ; \overline{RE} = 0V, DIN = V _{CC} or GND, R _L = 27Ω			160	210	mA
I _{CCS}	Power Supply Current (SCAN Test Mode), Drivers and Receivers Enabled	DE = V _{CC} ; \overline{RE} = 0V, DIN = V _{CC} or GND, R _L = 27Ω, TAP in any state other than Test-Logic-Reset			180	230	mA
I _{OFF}	Power Off Leakage Current	V _{CC} = 0V or OPEN, D _{IN} , DE, \overline{RE} = 0V or OPEN, V _{APPLIED} = 3.6V (Port Pins)	DO+/RI+, DO-/RI-	-20		+20	μA
C _{OUTPUT}	Capacitance @ Bus Pins		DO+/RI+, DO-/RI-		5		pF
C _{OUTPUT}	Capacitance @ R _{OUT}		R _{OUT}		7		pF

AC ELECTRICAL CHARACTERISTICS

 Over recommended operating supply voltage and temperature ranges unless otherwise specified ⁽¹⁾

Symbol	Parameter	Conditions	Min	Typ	Max	Units
DIFFERENTIAL DRIVER TIMING REQUIREMENTS						
t _{PHLD}	Differential Prop. Delay High to Low ⁽²⁾	R _L = 27Ω, See Figure 5 and Figure 6 C _L = 10 pF	1.0	1.8	2.6	ns
t _{PLHD}	Differential Prop. Delay Low to High ⁽²⁾		1.0	1.8	2.6	ns
t _{SKD1}	Differential Skew t _{PHLD} - t _{PLHD} ⁽³⁾		120			ps
t _{SKD2}	Chip to Chip Skew ⁽⁴⁾				1.6	ns
t _{SKD3}	Channel to Channel Skew ⁽⁵⁾			0.25	0.55	ns
t _{TLH}	Transition Time Low to High			0.5	1.2	ns
t _{THL}	Transition Time High to Low			0.5	1.2	ns
t _{PHZ}	Disable Time High to Z	R _L = 27Ω, See Figure 7 and Figure 8 C _L = 10 pF		3	8	ns
t _{PLZ}	Disable Time Low to Z			3	8	ns
t _{PZH}	Enable Time Z to High			3	8	ns
t _{PZL}	Enable Time Z to Low			3	8	ns
DIFFERENTIAL RECEIVER TIMING REQUIREMENTS						
t _{PHLD}	Differential Prop. Delay High to Low ⁽²⁾	See Figure 9 and Figure 10 C _L = 35 pF	2.0	2.4	3.9	ns
t _{PLHD}	Differential Prop Delay Low to High ⁽²⁾		2.0	2.4	3.9	ns
t _{SDK1}	Differential Skew t _{PHLD} - t _{PLHD} ⁽³⁾		210			ps
t _{SDK2}	Chip to Chip Skew ⁽⁴⁾				1.9	ns
t _{SDK3}	Channel to Channel skew ⁽⁵⁾			0.35	0.7	ns
t _{TLH}	Transition Time Low to High			1.5	2.5	ns
t _{THL}	Transition Time High to Low			1.5	2.5	ns

- (1) Generator waveforms for all tests unless otherwise specified: f = 25 MHz, Z_O = 50Ω, t_r, t_f = <1.0 ns (0%–100%). To ensure fastest propagation delay and minimum skew, data input edge rates should be equal to or faster than 1ns/V; control signals equal to or faster than 3ns/V. In general, the faster the input edge rate, the better the AC performance.
- (2) Propagation delays are specified by design and characterization.
- (3) t_{SKD1} |t_{PHLD} - t_{PLHD}| is the worse case skew between any channel and any device over recommended operation conditions.
- (4) Chip to Chip skew is the difference in differential propagation delay between any channels of any devices, either edge.
- (5) Channel to Channel skew is the difference in driver output or receiver output propagation delay between any channels within a device, common edge.

AC ELECTRICAL CHARACTERISTICS (continued)Over recommended operating supply voltage and temperature ranges unless otherwise specified ⁽¹⁾

Symbol	Parameter	Conditions	Min	Typ	Max	Units
t_{PHZ}	Disable Time High to Z	$R_L = 500\Omega$, See Figure 11 and Figure 12 $C_L = 35\text{ pF}$		4.5	10	ns
t_{PLZ}	Disable Time Low to Z			3.5	8	ns
t_{PZH}	Enable Time Z to High			3.5	8	ns
t_{PZL}	Enable Time Z to Low			3.5	8	ns
SCAN CIRCUITRY TIMING REQUIREMENTS						
f_{MAX}	Maximum TCK Clock Frequency	$R_L = 500\Omega$, $C_L = 35\text{ pF}$	25.0	75.0		MHz
t_S	TDI to TCK, H or L		1.5			ns
t_H	TDI to TCK, H or L		1.5			ns
t_S	TMS to TCK, H or L		2.5			ns
t_H	TMS to TCK, H or L		1.5			ns
t_W	TCK Pulse Width, H or L		10.0			ns
t_W	$\overline{\text{TRST}}$ Pulse Width, L		2.5			ns
t_{REC}	Recovery Time, $\overline{\text{TRST}}$ to TCK		2.0			ns

APPLICATIONS INFORMATION

General application guidelines and hints may be found in the following application notes: AN-808 ([SNLA028](#)), AN-1108 ([SNLA008](#)), AN-977 ([SNLA166](#)), AN-971 ([SNLA165](#)), and AN-903 ([SNLA034](#)).

There are a few common practices which should be implied when designing PCB for Bus LVDS signaling. Recommended practices are:

- Use at least 4 PCB board layer (Bus LVDS signals, ground, power and TTL signals).
- Keep drivers and receivers as close to the (Bus LVDS port side) connector as possible.
- Bypass each Bus LVDS device and also use distributed bulk capacitance between power planes. Surface mount capacitors placed close to power and ground pins work best. Two or three high frequency, multi-layer ceramic (MLC) surface mount (0.1 μF , 0.01 μF , 0.001 μF) in parallel should be used between each V_{CC} and ground. The capacitors should be as close as possible to the V_{CC} pin.
 - Multiple vias should be used to connect V_{CC} and Ground planes to the pads of the by-pass capacitors.
 - In addition, randomly distributed by-pass capacitors should be used.
- Use the termination resistor which best matches the differential impedance of your transmission line.
- Leave unused Bus LVDS receiver inputs open (floating). Limit traces on unused inputs to <0.5 inches.
- Isolate TTL signals from Bus LVDS signals

MEDIA (CONNECTOR or BACKPLANE) SELECTION:

- Use controlled impedance media. The backplane and connectors should have a matched differential impedance.

Table 1. Functional Table

MODE SELECTED	DE	$\overline{\text{RE}}$
DRIVER MODE	H	H
RECEIVER MODE	L	L
tri-state MODE	L	H
LOOP BACK MODE	H	L

Table 2. Transmitter Mode

INPUTS		OUTPUTS	
DE	D_{IN}	DO+	DO-
H	L	L	H
H	H	H	L
H	$0.8V < D_{IN} < 2.0V$	X	X
L	X	Z	Z

Table 3. Receiver Mode⁽¹⁾

INPUTS		OUTPUT
$\overline{\text{RE}}$	(RI+) – (RI-)	
L	L (< -100 mV)	L
L	H (> +100 mV)	H
L	$-100 \text{ mV} < V_{ID} < +100 \text{ mV}$	X
H	X	Z

- (1) X = High or Low logic state
 L = Low state
 Z = High impedance state
 H = High state

TEST CIRCUITS AND TIMING WAVEFORMS

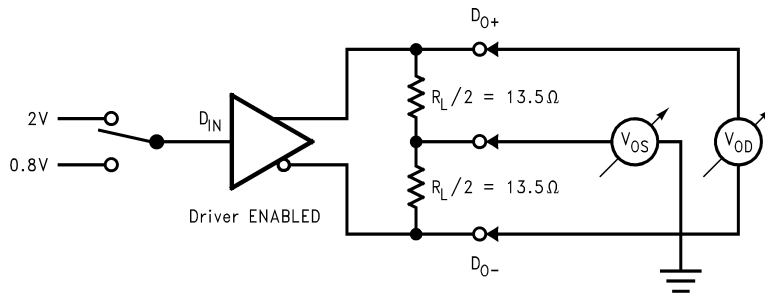

Figure 4. Differential Driver DC Test Circuit

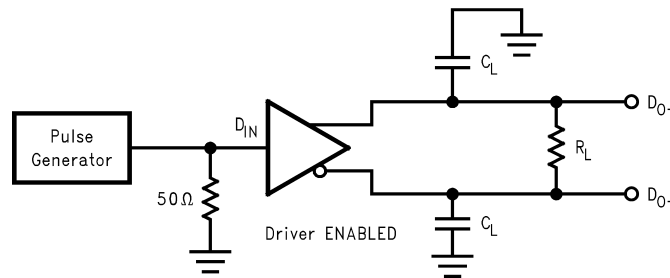

Figure 5. Differential Driver Propagation Delay and Transition Time Test Circuit

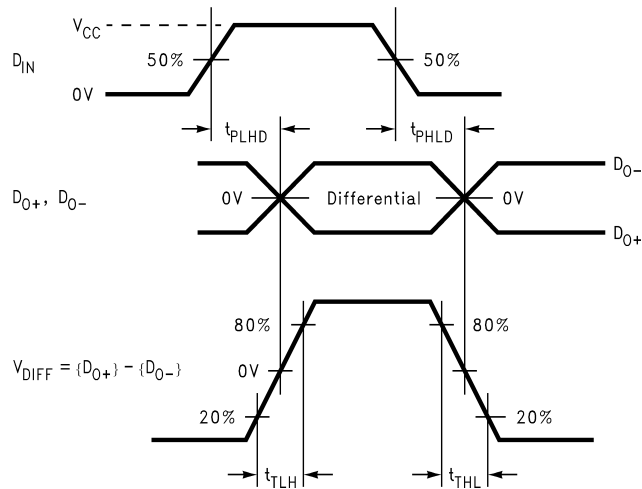

Figure 6. Differential Driver Propagation Delay and Transition Time Waveforms

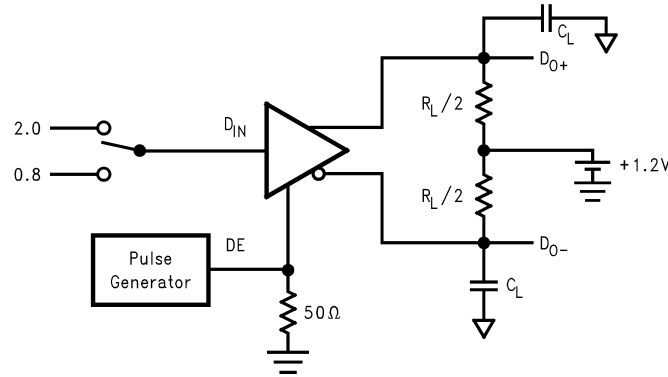

Figure 7. Driver Tri-State Delay Test Circuit

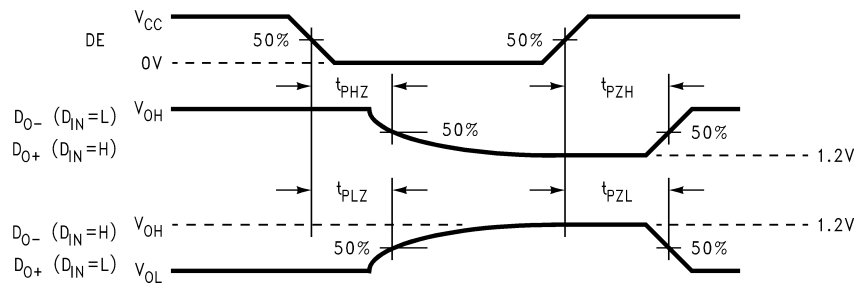

Figure 8. Driver Tri-State Delay Waveforms

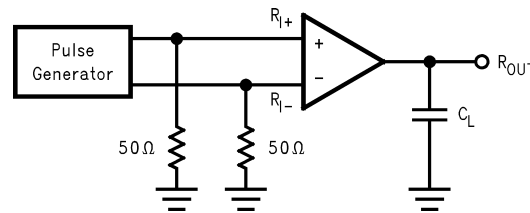

Figure 9. Receiver Propagation Delay and Transition Time Test Circuit

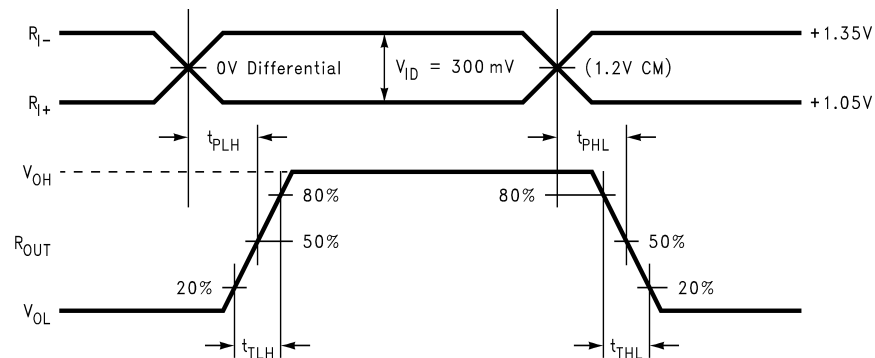

Figure 10. Receiver Propagation Delay and Transition Time Waveforms

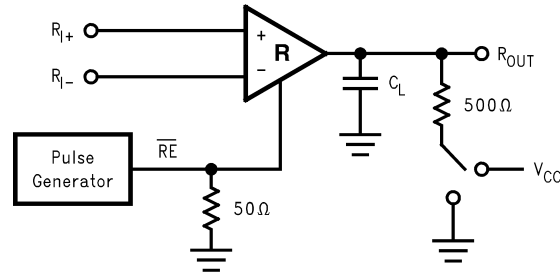

Figure 11. Receiver Tri-State Delay Test Circuit

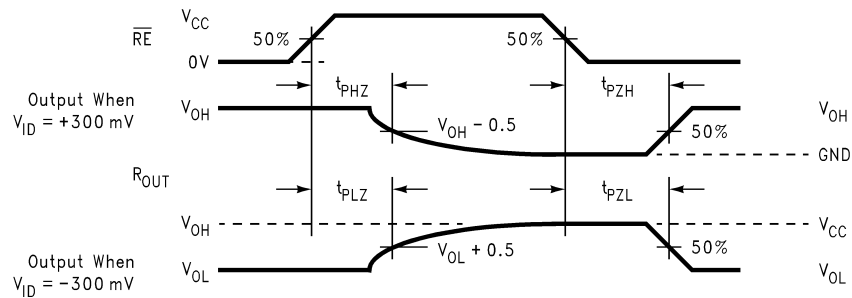

Figure 12. Receiver Tri-State Delay Waveforms

TYPICAL BUS APPLICATION CONFIGURATIONS

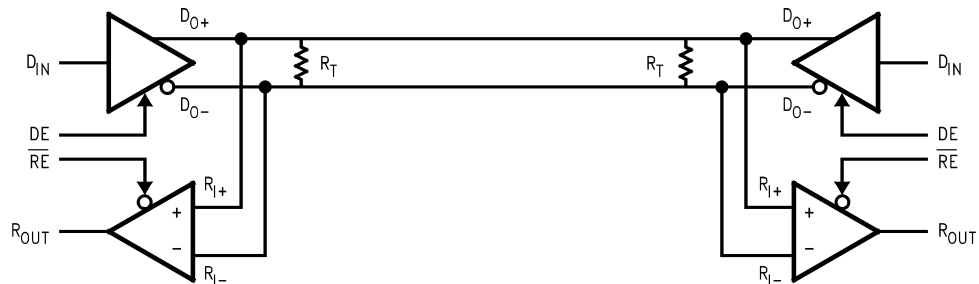

Figure 13. Bi-Directional Half-Duplex Point-to-Point Applications

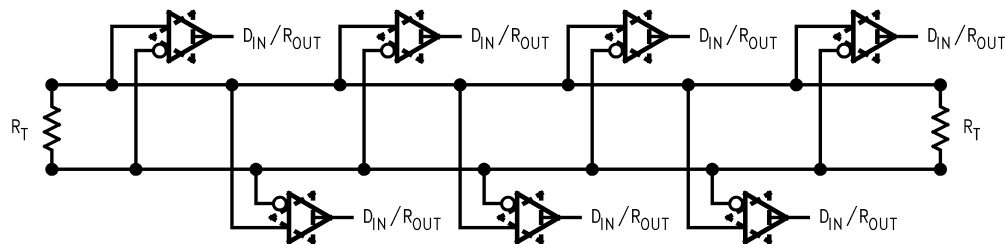

Figure 14. Multi-Point Bus Applications

DESCRIPTION OF BOUNDARY-SCAN CIRCUITRY

The SCAN92LV090 features two unique Scan test modes, each which requires a unique BSDL model depending on the level of test access and fault coverage goals. In the first mode (Mode0), only the TTL Inputs and Outputs of each transceiver are accessible via a 1149.1 compliant protocol. In the second mode (Mode1), both the TTL Inputs and Outputs and the differential LVDS I/Os are included in the Scan chain.

All test modes are handled by the ATPG software, and BSDL selection should be invisible to the user.

The BYPASS register is a single bit shift register stage identical to scan cell TYPE1. It captures a fixed logic low.

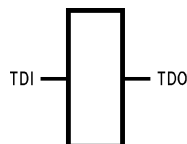

**Figure 15. Bypass Register Scan Chain Definition
Logic 0**

The INSTRUCTION register is an eight-bit register which captures the value 00111101.

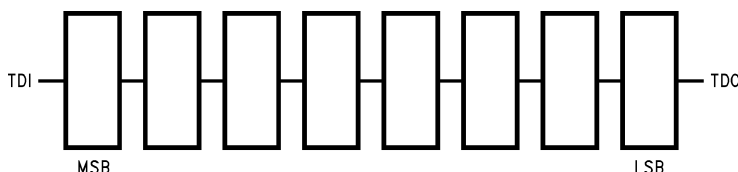

Figure 16. Instruction Register Scan Chain Definition

Table 4. MSB → LSB (Mode0)

Instruction Code	Instruction
00000000	EXTEST
10000010	SAMPLE/PRELOAD
10000111	CLAMP
00000110	HIGHZ
All Others	BYPASS

Table 5. MSB → LSB (Mode1)

Instruction Code	Instruction
10011001	EXTEST
10010010	SAMPLE/PRELOAD
10001111	CLAMP
00000110	HIGHZ
All Others	BYPASS

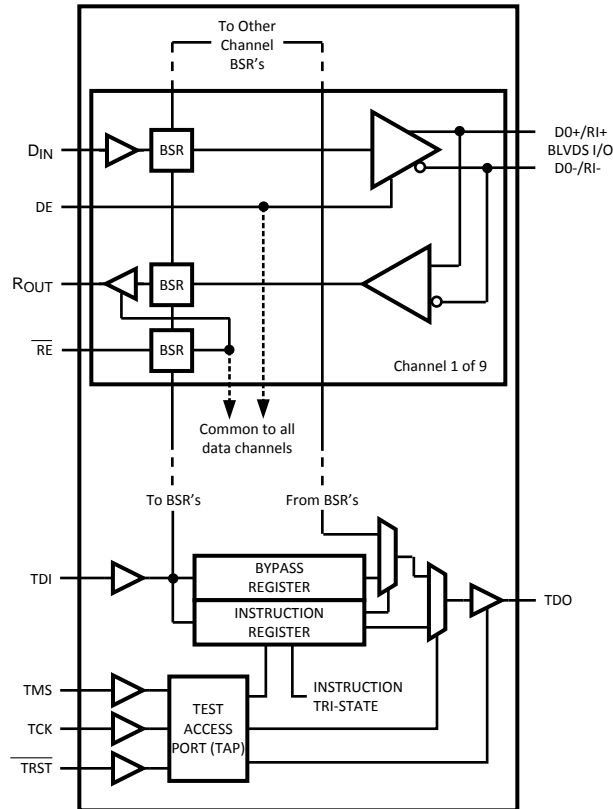

Figure 17. Mode 0 Boundary Scan Register Configuration
 (Refer to the BSDL for exact register order)

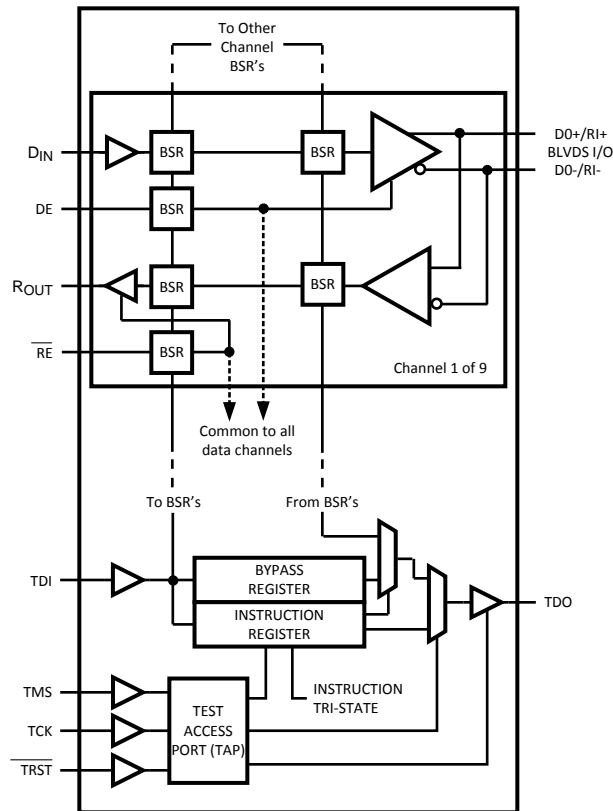

Figure 18. Mode 1 Boundary Scan Register Configuration
(Refer to the BSDL for exact register order)

REVISION HISTORY

Changes from Revision H (April 2013) to Revision I	Page
• Changed layout of National Data Sheet to TI format	13

PACKAGING INFORMATION

Orderable Device	Status (1)	Package Type	Package Drawing	Pins	Package Qty	Eco Plan (2)	Lead/Ball Finish (6)	MSL Peak Temp (3)	Op Temp (°C)	Device Marking (4/5)	Samples
SCAN92LV090SLC	NRND	NFBGA	NZC	64	360	TBD	Call TI	Call TI	-40 to 85	SCAN92LV090 SLC	
SCAN92LV090SLC/NOPB	ACTIVE	NFBGA	NZC	64	360	Green (RoHS & no Sb/Br)	SNAGCU	Level-4-260C-72 HR	-40 to 85	SCAN92LV090 SLC	Samples
SCAN92LV090VEH/NOPB	ACTIVE	LQFP	PM	64	160	Green (RoHS & no Sb/Br)	CU SN	Level-3-260C-168 HR	-40 to 85	SCAN92LV090 VEH	Samples

(1) The marketing status values are defined as follows:

ACTIVE: Product device recommended for new designs.

LIFEBUY: TI has announced that the device will be discontinued, and a lifetime-buy period is in effect.

NRND: Not recommended for new designs. Device is in production to support existing customers, but TI does not recommend using this part in a new design.

PREVIEW: Device has been announced but is not in production. Samples may or may not be available.

OBSOLETE: TI has discontinued the production of the device.

(2) Eco Plan - The planned eco-friendly classification: Pb-Free (RoHS), Pb-Free (RoHS Exempt), or Green (RoHS & no Sb/Br) - please check <http://www.ti.com/productcontent> for the latest availability information and additional product content details.

TBD: The Pb-Free/Green conversion plan has not been defined.

Pb-Free (RoHS): TI's terms "Lead-Free" or "Pb-Free" mean semiconductor products that are compatible with the current RoHS requirements for all 6 substances, including the requirement that lead not exceed 0.1% by weight in homogeneous materials. Where designed to be soldered at high temperatures, TI Pb-Free products are suitable for use in specified lead-free processes.

Pb-Free (RoHS Exempt): This component has a RoHS exemption for either 1) lead-based flip-chip solder bumps used between the die and package, or 2) lead-based die adhesive used between the die and leadframe. The component is otherwise considered Pb-Free (RoHS compatible) as defined above.

Green (RoHS & no Sb/Br): TI defines "Green" to mean Pb-Free (RoHS compatible), and free of Bromine (Br) and Antimony (Sb) based flame retardants (Br or Sb do not exceed 0.1% by weight in homogeneous material)

(3) MSL, Peak Temp. - The Moisture Sensitivity Level rating according to the JEDEC industry standard classifications, and peak solder temperature.

(4) There may be additional marking, which relates to the logo, the lot trace code information, or the environmental category on the device.

(5) Multiple Device Markings will be inside parentheses. Only one Device Marking contained in parentheses and separated by a "~" will appear on a device. If a line is indented then it is a continuation of the previous line and the two combined represent the entire Device Marking for that device.

(6) Lead/Ball Finish - Orderable Devices may have multiple material finish options. Finish options are separated by a vertical ruled line. Lead/Ball Finish values may wrap to two lines if the finish value exceeds the maximum column width.

Important Information and Disclaimer: The information provided on this page represents TI's knowledge and belief as of the date that it is provided. TI bases its knowledge and belief on information provided by third parties, and makes no representation or warranty as to the accuracy of such information. Efforts are underway to better integrate information from third parties. TI has taken and

continues to take reasonable steps to provide representative and accurate information but may not have conducted destructive testing or chemical analysis on incoming materials and chemicals. TI and TI suppliers consider certain information to be proprietary, and thus CAS numbers and other limited information may not be available for release.

In no event shall TI's liability arising out of such information exceed the total purchase price of the TI part(s) at issue in this document sold by TI to Customer on an annual basis.

NZC0064A

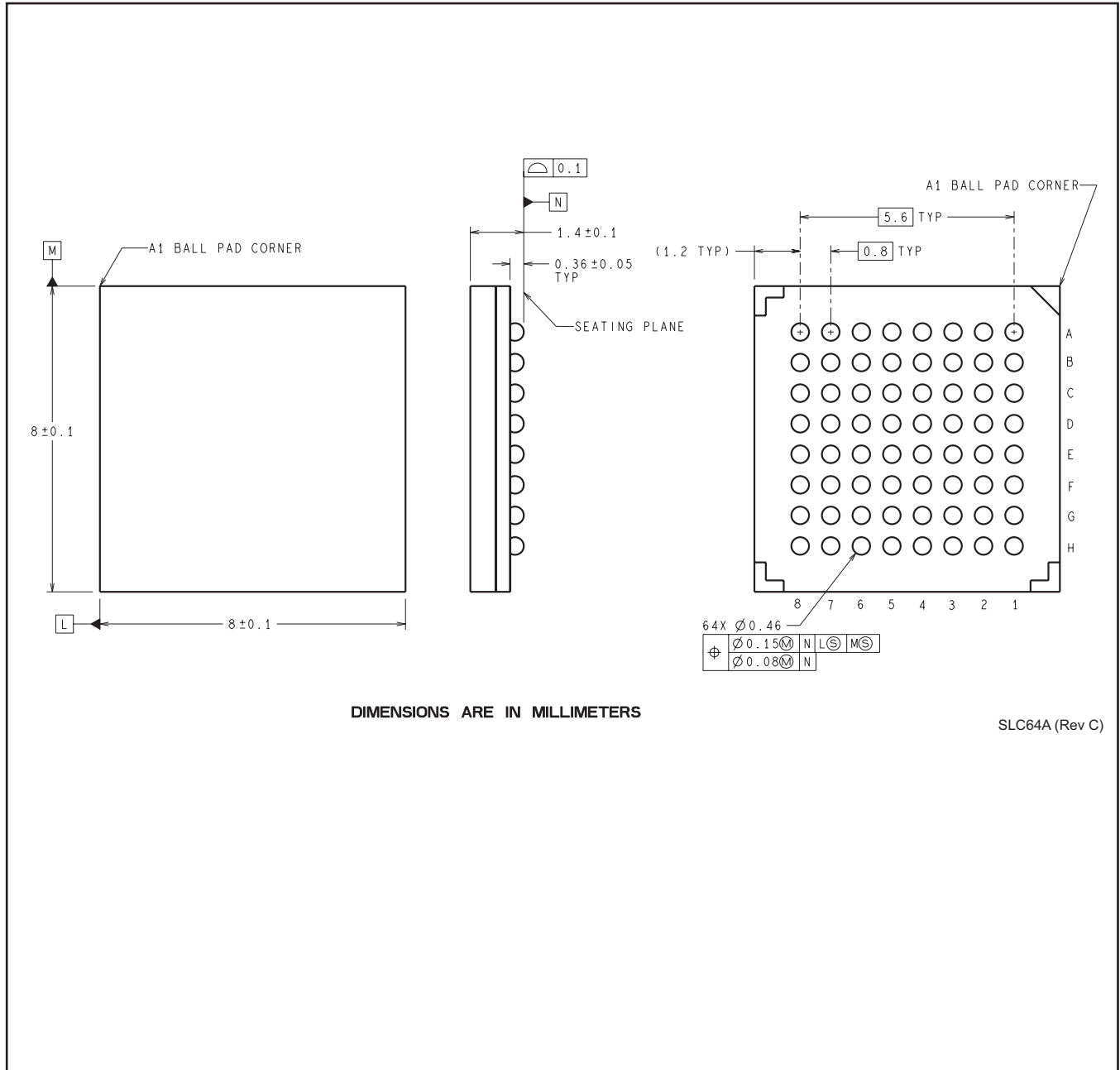

DIMENSIONS ARE IN MILLIMETERS

SLC64A (Rev C)

PM (S-PQFP-G64)

PLASTIC QUAD FLATPACK

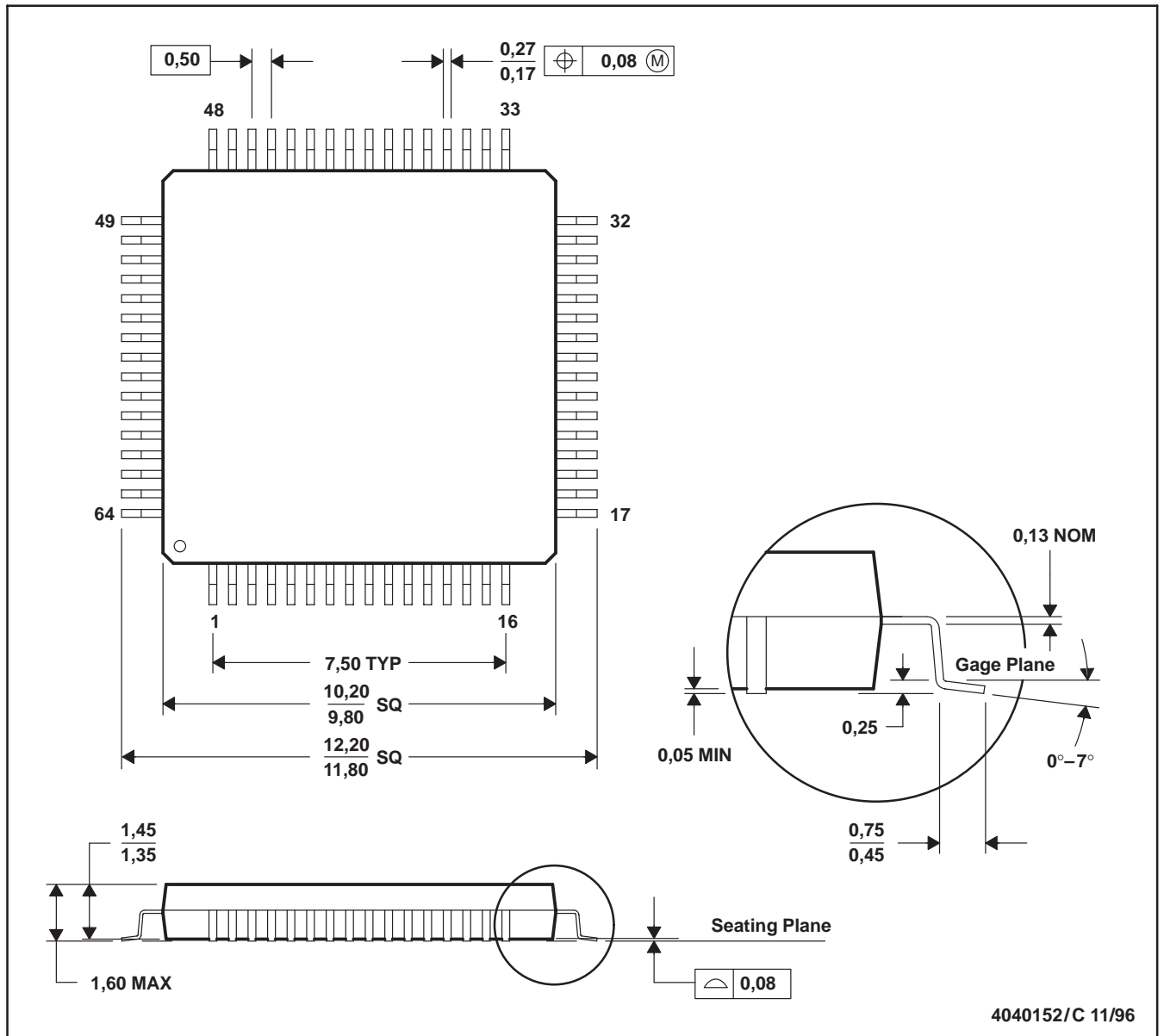

- NOTES: A. All linear dimensions are in millimeters.
 B. This drawing is subject to change without notice.
 C. Falls within JEDEC MS-026
 D. May also be thermally enhanced plastic with leads connected to the die pads.

4040152/C 11/96

IMPORTANT NOTICE

Texas Instruments Incorporated and its subsidiaries (TI) reserve the right to make corrections, enhancements, improvements and other changes to its semiconductor products and services per JESD46, latest issue, and to discontinue any product or service per JESD48, latest issue. Buyers should obtain the latest relevant information before placing orders and should verify that such information is current and complete. All semiconductor products (also referred to herein as "components") are sold subject to TI's terms and conditions of sale supplied at the time of order acknowledgment.

TI warrants performance of its components to the specifications applicable at the time of sale, in accordance with the warranty in TI's terms and conditions of sale of semiconductor products. Testing and other quality control techniques are used to the extent TI deems necessary to support this warranty. Except where mandated by applicable law, testing of all parameters of each component is not necessarily performed.

TI assumes no liability for applications assistance or the design of Buyers' products. Buyers are responsible for their products and applications using TI components. To minimize the risks associated with Buyers' products and applications, Buyers should provide adequate design and operating safeguards.

TI does not warrant or represent that any license, either express or implied, is granted under any patent right, copyright, mask work right, or other intellectual property right relating to any combination, machine, or process in which TI components or services are used. Information published by TI regarding third-party products or services does not constitute a license to use such products or services or a warranty or endorsement thereof. Use of such information may require a license from a third party under the patents or other intellectual property of the third party, or a license from TI under the patents or other intellectual property of TI.

Reproduction of significant portions of TI information in TI data books or data sheets is permissible only if reproduction is without alteration and is accompanied by all associated warranties, conditions, limitations, and notices. TI is not responsible or liable for such altered documentation. Information of third parties may be subject to additional restrictions.

Resale of TI components or services with statements different from or beyond the parameters stated by TI for that component or service voids all express and any implied warranties for the associated TI component or service and is an unfair and deceptive business practice. TI is not responsible or liable for any such statements.

Buyer acknowledges and agrees that it is solely responsible for compliance with all legal, regulatory and safety-related requirements concerning its products, and any use of TI components in its applications, notwithstanding any applications-related information or support that may be provided by TI. Buyer represents and agrees that it has all the necessary expertise to create and implement safeguards which anticipate dangerous consequences of failures, monitor failures and their consequences, lessen the likelihood of failures that might cause harm and take appropriate remedial actions. Buyer will fully indemnify TI and its representatives against any damages arising out of the use of any TI components in safety-critical applications.

In some cases, TI components may be promoted specifically to facilitate safety-related applications. With such components, TI's goal is to help enable customers to design and create their own end-product solutions that meet applicable functional safety standards and requirements. Nonetheless, such components are subject to these terms.

No TI components are authorized for use in FDA Class III (or similar life-critical medical equipment) unless authorized officers of the parties have executed a special agreement specifically governing such use.

Only those TI components which TI has specifically designated as military grade or "enhanced plastic" are designed and intended for use in military/aerospace applications or environments. Buyer acknowledges and agrees that any military or aerospace use of TI components which have **not** been so designated is solely at the Buyer's risk, and that Buyer is solely responsible for compliance with all legal and regulatory requirements in connection with such use.

TI has specifically designated certain components as meeting ISO/TS16949 requirements, mainly for automotive use. In any case of use of non-designated products, TI will not be responsible for any failure to meet ISO/TS16949.

Products

Audio	www.ti.com/audio
Amplifiers	amplifier.ti.com
Data Converters	dataconverter.ti.com
DLP® Products	www.dlp.com
DSP	dsp.ti.com
Clocks and Timers	www.ti.com/clocks
Interface	interface.ti.com
Logic	logic.ti.com
Power Mgmt	power.ti.com
Microcontrollers	microcontroller.ti.com
RFID	www.ti-rfid.com
OMAP Applications Processors	www.ti.com/omap
Wireless Connectivity	www.ti.com/wirelessconnectivity

Applications

Automotive and Transportation	www.ti.com/automotive
Communications and Telecom	www.ti.com/communications
Computers and Peripherals	www.ti.com/computers
Consumer Electronics	www.ti.com/consumer-apps
Energy and Lighting	www.ti.com/energy
Industrial	www.ti.com/industrial
Medical	www.ti.com/medical
Security	www.ti.com/security
Space, Avionics and Defense	www.ti.com/space-avionics-defense
Video and Imaging	www.ti.com/video

TI E2E Community

e2e.ti.com

Looking for pricing, stock, or lifecycle information?

Click below to explore more details on WIN SOURCE:

 [View SCAN92LV090VEHX/NOPB on WIN SOURCE](#)

 [Texas Instruments](#) Information

Optimize Your Supply Chain with WIN SOURCE Solutions

-  Global Sourcing Solution
-  Obsolete Management
-  Cost Control Management
-  Shortage Management
-  Alternative Solution
-  Excess Inventory Management