



**THE DATASHEET OF
LTC3853EUJ#PBF**



Triple Output, Multiphase Synchronous Step-Down Controller

FEATURES

- Triple, 120° Phased Controllers Reduce Required Input Capacitance and Power Supply Induced Noise
- Configurable as a 180° Dual Phase Controller Plus a Single Phase Controller
- The Third Phase Can Regulate Up to a 13.5V Output
- High Efficiency: Up to 92%
- R_{SENSE} or DCR Current Sensing
- $\pm 0.75\%$ 0.8V Output Voltage Accuracy
- Phase-Lockable Fixed Frequency 250kHz to 750kHz
- Supports Pre-Biased Outputs
- Dual N-Channel MOSFET Synchronous Drive
- Wide V_{IN} Range: 4.5V to 24V Operation (28V Abs Max)
- Adjustable Soft-Start Current Ramping or Tracking
- Foldback Output Current Limiting
- Output Overvoltage Protection
- Dual Power Good Output Voltage Monitors
- 40-Lead 6mm × 6mm QFN Package

LT, LT, LTC, LTM, Linear Technology, Burst Mode, Polyphase and the Linear logo are registered trademarks of Linear Technology Corporation. All other trademarks are the property of their respective owners. Protected by U.S. Patents, including 5481178, 5705919, 5929620, 6100678, 6144194, 6177787, 6304066, 6580258.

DESCRIPTION

The **LTC[®]3853** is a high performance triple output step-down switching regulator controller that drives all N-channel synchronous power MOSFET stages. Power loss and supply noise are minimized by operating the output stages out of phase. The part can be configured as a dual phase controller plus a single phase controller if needed. The part can also be configured to provide a single 3-phase output for even higher output currents.

A wide 4.5V to 24V (28V maximum) input voltage supply range encompasses most battery chemistries and intermediate bus voltages. Phase 3 can regulate output voltages up to 13.5V. A constant-frequency current mode architecture allows for a phase-lockable frequency up to 750kHz.

Independent TK/SS pins for each output ramps the output voltages and can be configured for coincident or ratiometric tracking. Current foldback limits MOSFET heat dissipation during short-circuit conditions. The MODE/PLLIN pin selects among Burst Mode[®] operation, pulse-skipping or continuous inductor current modes.

TYPICAL APPLICATION

High Efficiency Triple 5V/3.3V/1.2V Step-Down Converter

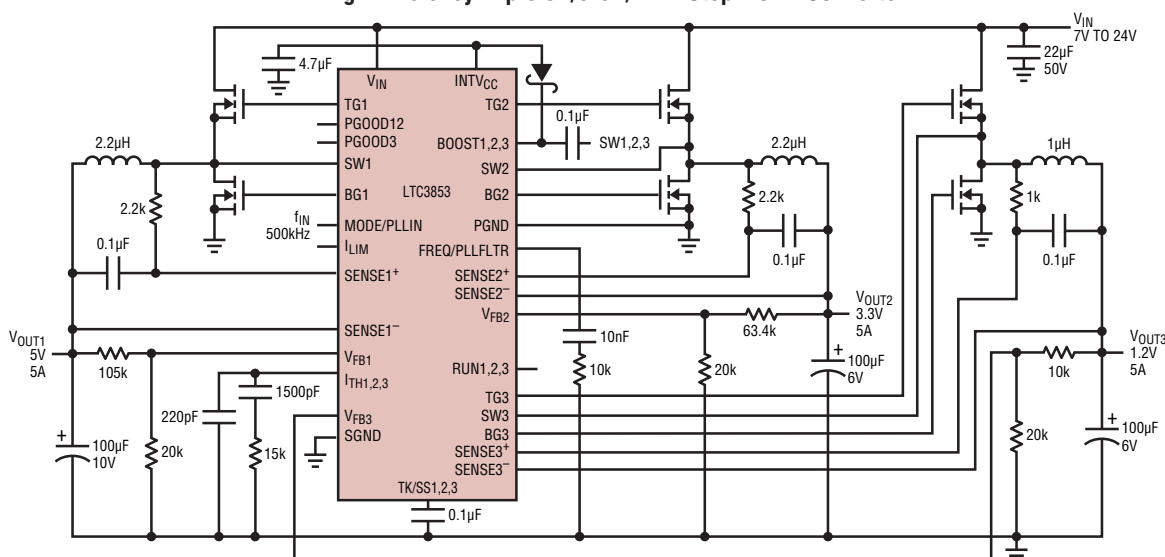

3853fc

ABSOLUTE MAXIMUM RATINGS

(Note 1)

Input Supply Voltage (V_{IN})	28V to -0.3V
Topside Driver Voltages	
BOOST1, BOOST2, BOOST3	34V to -0.3V
Switch Voltage (SW1, SW2, SW3)	28V to -5V
INTV _{CC} , RUN1, RUN2, RUN3, PGOOD12, PGOOD3, DRV _{CC12} , EXTV _{CC} , (BOOST1-SW1), (BOOST2-SW2), (BOOST3-SW3)	6V to -0.3V
SENSE1 ⁺ , SENSE2 ⁺ , SENSE1 ⁻ , SENSE2 ⁻ Voltages	5.7V to -0.3V
SENSE3 ⁺ , SENSE3 ⁻	14V to -0.3V
V_{FB2}	300 μ A Max I_{FB2}
MODE/PLLIN, I_{LIM} , TK/SS1, TK/SS2, TK/SS3 Voltages	INTV _{CC} to -0.3V
I_{TH1} , I_{TH2} , I_{TH3} , V_{FB1} , V_{FB3} Voltages	INTV _{CC} to -0.3V
INTV _{CC} Peak Output Current	150mA
Operating Junction Temperature Range (Note 3)	
E-Grade, I-Grade	-40°C to 125°C
H-Grade	-40°C to 150°C
MP-Grade	-55°C to 150°C
Storage Temperature Range	-65°C to 150°C

PIN CONFIGURATION

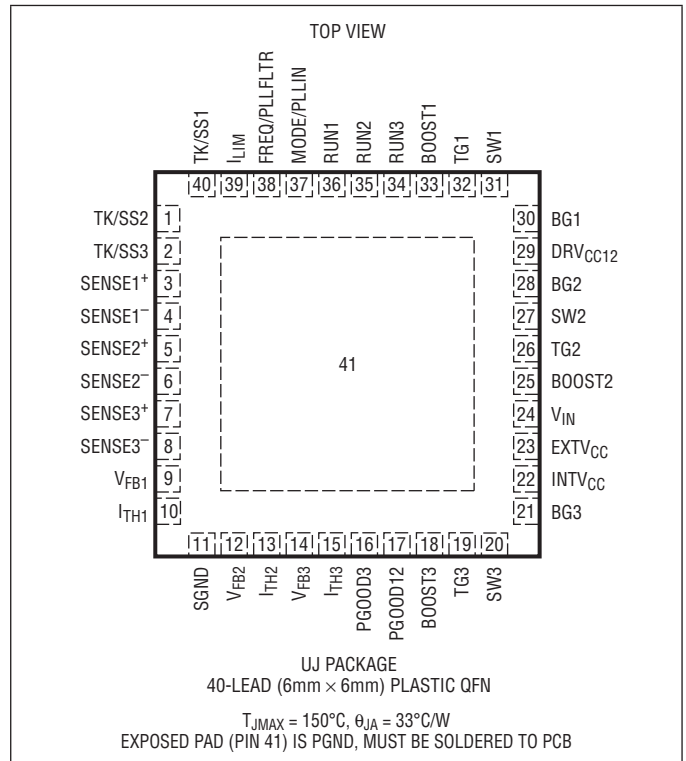

ORDER INFORMATION

LEAD FREE FINISH	TAPE AND REEL	PART MARKING*	PACKAGE DESCRIPTION	TEMPERATURE RANGE
LTC3853EUJ#PBF	LTC3853EUJ#TRPBF	LTC3853UJ	40-Lead (6mm × 6mm) Plastic QFN	-40°C to 125°C
LTC3853IUJ#PBF	LTC3853IUJ#TRPBF	LTC3853UJ	40-Lead (6mm × 6mm) Plastic QFN	-40°C to 125°C
LTC3853HUJ#PBF	LTC3853HUJ#TRPBF	LTC3853UJ	40-Lead (6mm × 6mm) Plastic QFN	-40°C to 150°C
LTC3853MPUJ#PBF	LTC3853MPUJ#TRPBF	LTC3853UJ	40-Lead (6mm × 6mm) Plastic QFN	-55°C to 150°C

Consult LTC Marketing for parts specified with wider operating temperature ranges. *The temperature grade is identified by a label on the shipping container

For more information on lead free part marking, go to: <http://www.linear.com/leadfree/>

For more information on tape and reel specifications, go to: <http://www.linear.com/tapeandreeel/>

ELECTRICAL CHARACTERISTICS

The ● denotes the specifications which apply over the full operating junction temperature range, otherwise specifications are at $T_A = 25^\circ\text{C}$ (Note 3), $V_{IN} = 15\text{V}$, $V_{RUN1,2,3} = 5\text{V}$, unless otherwise noted.

SYMBOL	PARAMETER	CONDITIONS	MIN	TYP	MAX	UNITS	
Main Control Loops							
	Output Voltage Range	Channels 1, 2		0.8	5.5	V	
		Channel 3		0.8	13.5	V	
$V_{FB1,2,3}$	Regulated Feedback Voltage	$I_{TH1,2,3}$ Voltage = 1.2V, -55°C to 150°C (Note 4)	●	0.790	0.800	0.810	V
		$I_{TH1,2,3}$ Voltage = 1.2V, -40°C to 125°C (Note 4)	●	0.792	0.800	0.808	V
		$I_{TH1,2,3}$ Voltage = 1.2V, 0°C to 85°C (Note 4)		0.794	0.800	0.806	V
	Feedback Current	(Note 4)		-10	-50	nA	
	Reference Voltage Line Regulation	$V_{IN} = 6\text{V}$ to 24V (Note 4)		0.002	0.02	%/V	
	Output Voltage Load Regulation	(Note 4) Measured in Servo Loop; ΔI_{TH} Voltage = 1.2V to 0.7V	●		0.01	0.1	%
		Measured in Servo Loop; ΔI_{TH} Voltage = 1.2V to 1.6V	●		-0.01	-0.1	%
	Transconductance Amplifier g_m	$I_{TH1,2,3} = 1.2\text{V}$, Sink/Source $5\mu\text{A}$ (Note 4)		2.2		mmho	
I_Q	Input DC Supply Current Normal Mode Shutdown	(Note 5) $V_{IN} = 15\text{V}$ $V_{RUN1,2,3} = 0\text{V}$		4.1		mA	
				42	70	μA	
UVLO	Undervoltage Lockout on $INTV_{CC}$	$V_{INTV_{CC}}$ Ramping Down		3.35		V	
	UVLO Hysteresis			0.5		V	
	Feedback Overvoltage Lockout	Measured at $V_{FB1,2,3}$ (H-Grade, MP-Grade)	●	0.84	0.86	0.89	V
		Measured at $V_{FB1,2,3}$	●	0.84	0.86	0.88	V
I_{SENSE}	Sense Pin Current	$V_{SENSE} = 3.3\text{V}$		± 1	± 2	μA	
	Soft-Start Charge Current	$V_{TK/SS1,2,3} = 0\text{V}$		0.9	1.3	1.7	μA
$V_{RUN1,2,3}$	RUN Pin ON Threshold	V_{RUN1} , V_{RUN2} , V_{RUN3} Rising	●	1.1	1.2	1.35	V
	RUN Pin Hysteresis			80		mV	
	Maximum Current Sense Threshold	$I_{TH1,2,3} = 1.85\text{V}$, $V_{SENSE1,2,3} = 3.3\text{V}$, $I_{LIM} = 0\text{V}$	●	22	30	38	mV
		$I_{TH1,2,3} = 1.85\text{V}$, $V_{SENSE1,2,3} = 3.3\text{V}$, $I_{LIM} = 0\text{V}$ (H-, MP-Grade)	●	21	30	39	mV
		$I_{TH1,2,3} = 1.85\text{V}$, $V_{SENSE1,2,3} = 3.3\text{V}$, $I_{LIM} = \text{Float}$	●	42	50	58	mV
		$I_{TH1,2,3} = 1.85\text{V}$, $V_{SENSE1,2,3} = 3.3\text{V}$, $I_{LIM} = \text{Float}$ (H-, MP-Grade)	●	41	50	59	mV
		$I_{TH1,2,3} = 1.85\text{V}$, $V_{SENSE1,2,3} = 3.3\text{V}$, $I_{LIM} = INTV_{CC}$	●	65	75	85	mV
		$I_{TH1,2,3} = 1.85\text{V}$, $V_{SENSE1,2,3} = 3.3\text{V}$, $I_{LIM} = INTV_{CC}$ (H-, MP-Grade)	●	64	75	86	mV
	Maximum Duty Factor	In Dropout		97	98	%	
	TG Driver Pull-Up On-Resistance	TG High		2.6		Ω	
	TG Driver Pull-Down On-Resistance	TG Low		1.5		Ω	
	BG Driver Pull-Up On-Resistance	BG High		2.4		Ω	
	BG Driver Pull-Down On-Resistance	BG Low		1.1		Ω	
	TG Transition Time: Rise Time Fall Time	(Note 6) $C_{LOAD} = 3300\text{pF}$ $C_{LOAD} = 3300\text{pF}$			25	ns	
					25	ns	
	BG Transition Time: Rise Time Fall Time	(Note 6) $C_{LOAD} = 3300\text{pF}$ $C_{LOAD} = 3300\text{pF}$			25	ns	
					25	ns	
	Top Gate Off to Bottom Gate On Delay Synchronous Switch-On Delay Time	(Note 6) $C_{LOAD} = 3300\text{pF}$ Each Driver			30	ns	

ELECTRICAL CHARACTERISTICS

The ● denotes the specifications which apply over the full operating junction temperature range, otherwise specifications are at $T_A = 25^\circ\text{C}$ (Note 3), $V_{IN} = 15\text{V}$, $V_{RUN1,2,3} = 5\text{V}$, unless otherwise noted.

SYMBOL	PARAMETER	CONDITIONS	MIN	TYP	MAX	UNITS
$t_{ON(MIN)}$	Bottom Gate Off to Top Gate On Delay	(Note 6)				
	Top Switch-On Delay Time	$C_{LOAD} = 3300\text{pF}$ Each Driver		30		ns
$t_{ON(MIN)}$	Minimum On-Time	(Note 7)		90		ns
INTV_{CC} Linear Regulator						
V_{INTVCC}	Internal V _{CC} Voltage	$7\text{V} < V_{IN} < 24\text{V}$	4.8	5	5.2	V
	INTV _{CC} Load Regulation	$I_{CC} = 0\text{mA}$ to 50mA		0.5	2	%
V_{EXTVCC}	EXTV _{CC} Switchover Voltage	EXTV _{CC} Ramping Positive	● 4.5	4.7		V
	EXTV _{CC} Voltage Drop	$I_{CC} = 20\text{mA}$, $V_{EXTVCC} = 5\text{V}$		30	75	mV
	EXTV _{CC} Hysteresis			200		mV
Oscillator and Phase-Locked Loop						
	Nominal Frequency	$V_{FREQ} = 1.2\text{V}$	450	500	550	kHz
	Lowest Frequency	$V_{FREQ} = 0\text{V}$	210	250	290	kHz
	Highest Frequency	$V_{FREQ} \geq 2.4\text{V}$	670	750	830	kHz
	Channel 2-Channel 1 Phase Channel 3-Channel 2 Phase Channel 1-Channel 3 Phase			120		Deg Deg Deg
	Channel 2-Channel 1 Phase Channel 3-Channel 2 Phase Channel 1-Channel 3 Phase	V_{FB2} Tied to V_{IN} Through $200\text{k}\Omega$		180 60 120		Deg Deg Deg
	MODE/PLLIN Input Resistance			250		k Ω
I_{FREQ}	Phase Detector Output Current Sinking Capability Sourcing Capability	$f_{MODE} < f_{OSC}$ $f_{MODE} > f_{OSC}$		-13 13		μA μA
PGOOD Outputs						
	PGOOD Voltage Low	$I_{PGOOD} = 2\text{mA}$		0.1	0.3	V
I_{PGOOD}	PGOOD Leakage Current	$V_{PGOOD} = 5\text{V}$			± 2	μA
	PGOOD Trip Level	V_{FB} with Respect to Set Regulated Voltage V_{FB} Ramping Negative V_{FB} Ramping Positive	-5 5	-7.5 7.5	-10 10	% %

Note 1: Stresses beyond those listed under Absolute Maximum Ratings may cause permanent damage to the device. Exposure to any Absolute Maximum Rating condition for extended periods may affect device reliability and lifetime.

Note 2: The junction temperature, T_J , is calculated from the ambient temperature T_A and power dissipation P_D according to the following formulas:

$$LTC3853UJ: T_J = T_A + (P_D \cdot 33^\circ\text{C/W})$$

Note 3: The LTC3853 is tested under pulsed load conditions such that $T_J \approx T_A$. The LTC3853E is guaranteed to meet performance specifications from 0°C to 85°C junction temperature. Specifications over the -40°C to 125°C operating junction temperature range are assured by design, characterization and correlation with statistical process controls. The LTC3853I is guaranteed over the -40°C to 125°C operating junction temperature range. The LTC3853H is guaranteed over the -40°C to 150°C operating junction temperature range and the LTC3853MP is tested and

guaranteed over the -55°C to 150°C operating junction temperature range. High junction temperatures degrade operating lifetimes; operating lifetime is derated for junction temperatures greater than 125°C . The maximum ambient temperature consistent with these specifications is determined by specific operating conditions in conjunction with board layout, the rated package thermal resistance and other environmental factors.

Note 4: The LTC3853 is tested in a feedback loop that servos $V_{ITH1,2,3}$ to a specified voltage and measures the resultant $V_{FB1,2,3}$.

Note 5: Dynamic supply current is higher due to the gate charge being delivered at the switching frequency. See the Applications Information section.

Note 6: Rise and fall times are measured using 10% and 90% levels. Delay times are measured using 50% levels.

Note 7: The minimum on-time condition is specified for an inductor peak-to-peak ripple current $\geq 40\%$ of I_{MAX} (see Minimum On-Time Considerations in the Applications Information section).

TYPICAL PERFORMANCE CHARACTERISTICS

Efficiency vs Output Current and Mode

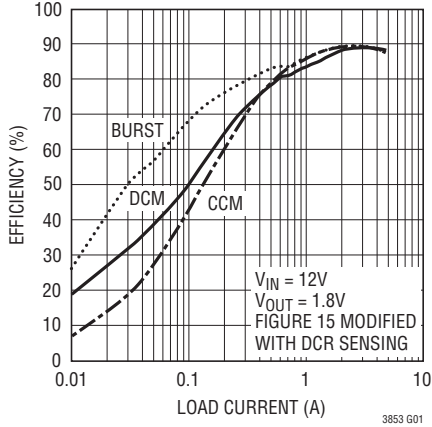

Efficiency vs Output Current and Mode

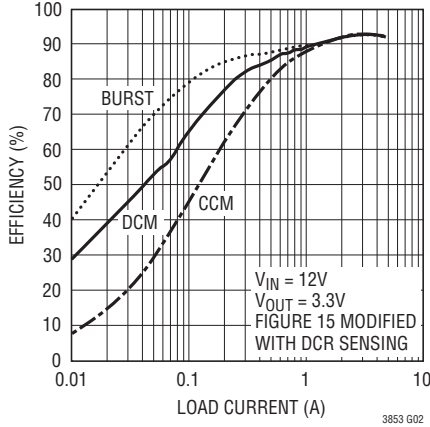

Efficiency and Power Loss vs Input Voltage

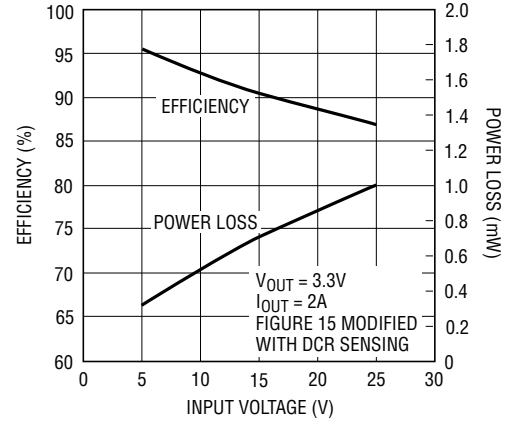

Load Step (Burst Mode Operation)

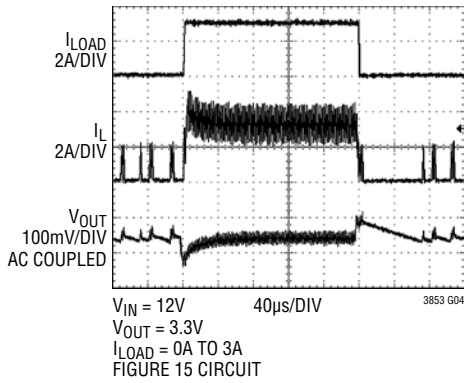

Load Step (Forced Continuous Mode)

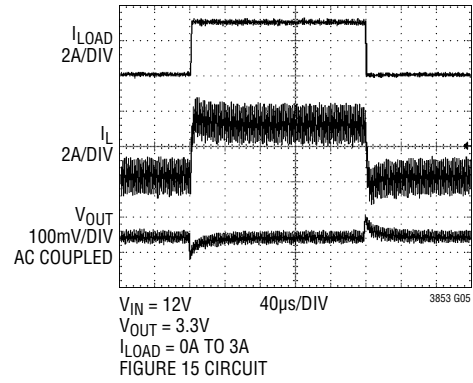

Load Step (Pulse Skip Mode)

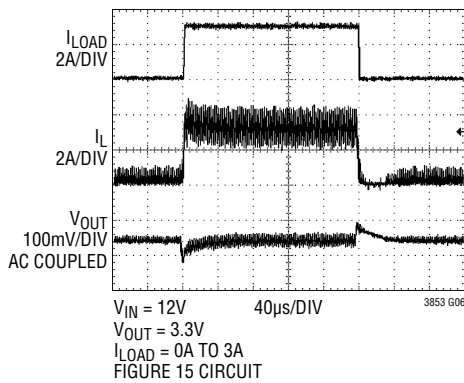

Inductor Current at Light Load

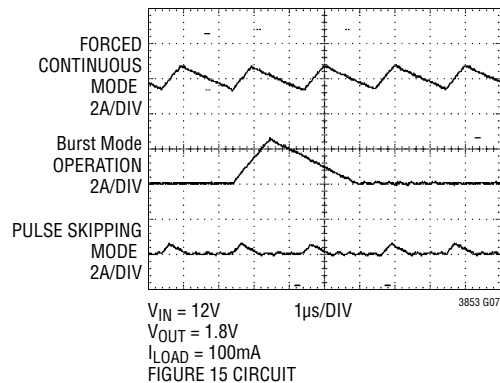

TYPICAL PERFORMANCE CHARACTERISTICS

Prebiased Output at 2V

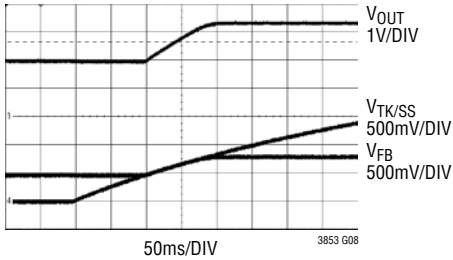

Coincident Tracking

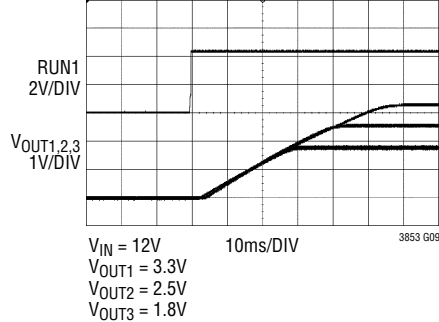

Tracking Up and Down with External Ramp

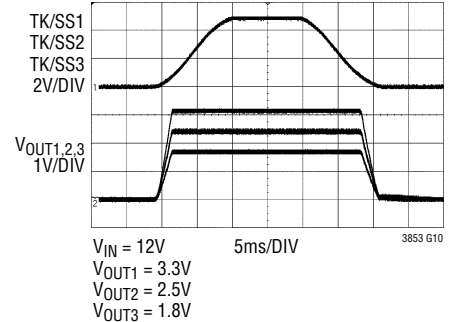

Quiescent Current vs Input Voltage Without EXTV_{CC}

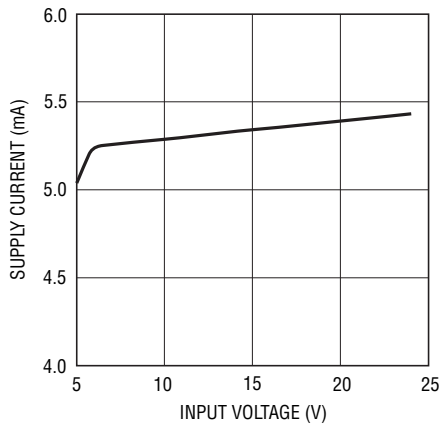

Internal V_{CC} Line Regulation

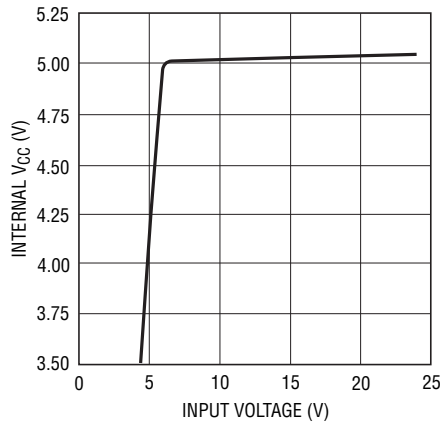

Current Sense Threshold vs I_{TH} Voltage

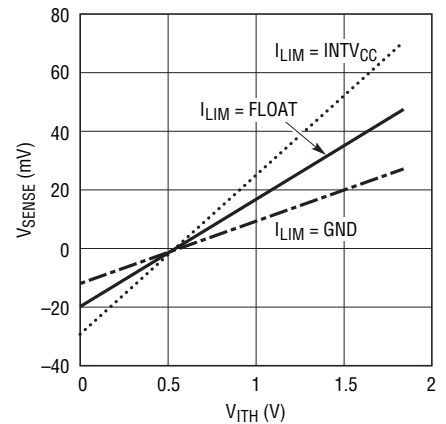

Maximum Current Sense Threshold vs Common Mode Voltage

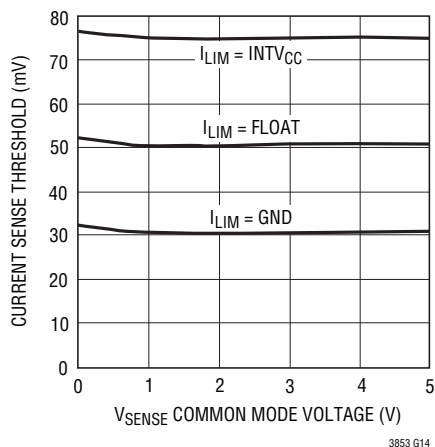

Maximum Current Sense Threshold vs Duty Cycle

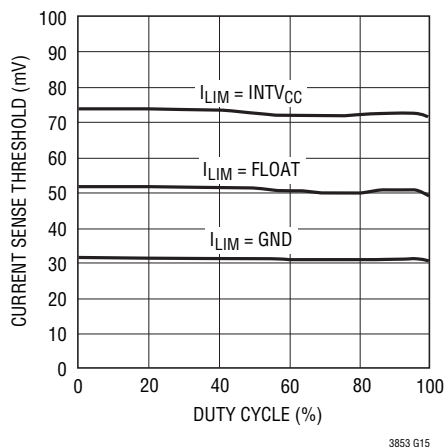

Maximum Current Sense Voltage vs Feedback Voltage (Current Foldback)

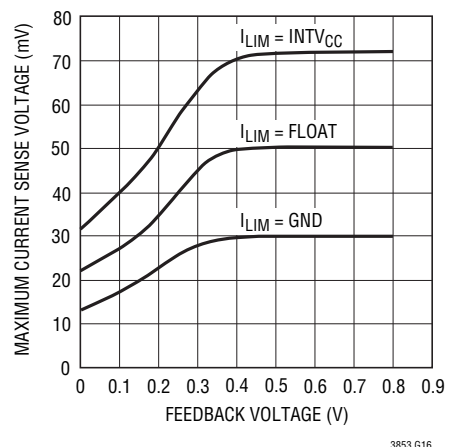

TYPICAL PERFORMANCE CHARACTERISTICS

TK/SS Pull-Up Current vs Temperature

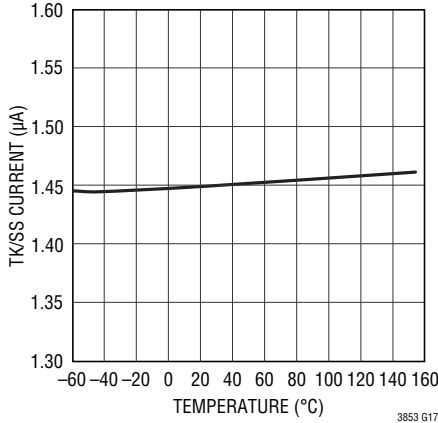

Shutdown (RUN) Threshold vs Temperature

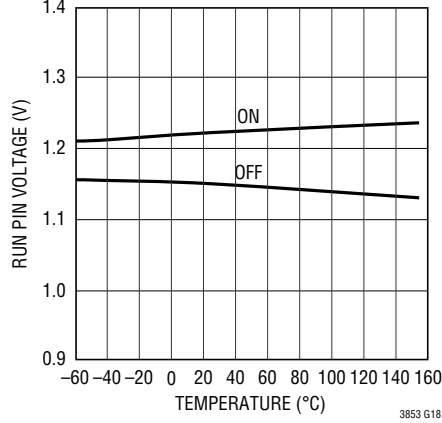

Regulated Feedback Voltage vs Temperature

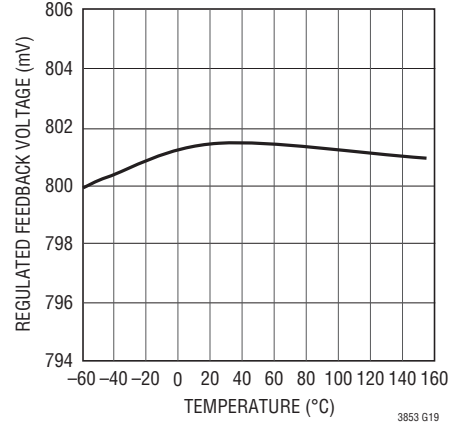

Oscillator Frequency vs Temperature

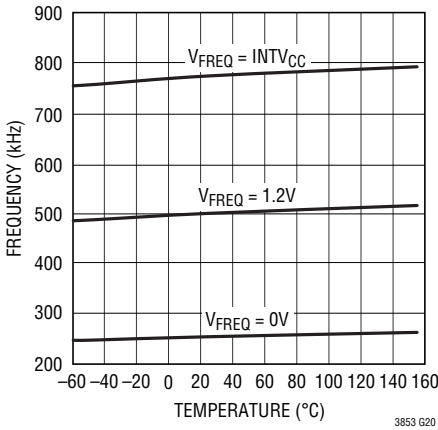

Undervoltage Lockout Threshold (INTV_{CC}) vs Temperature

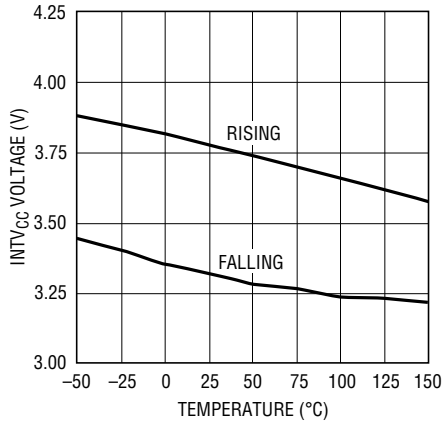

Oscillator Frequency vs Input Voltage

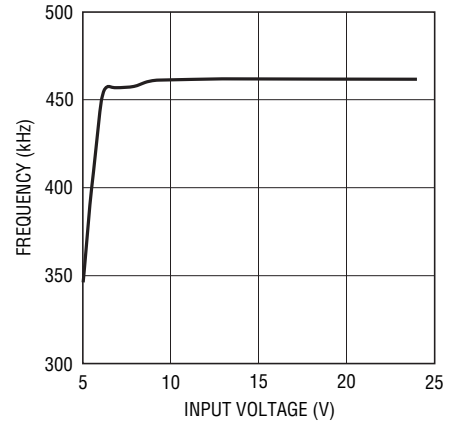

Shutdown Current vs Input Voltage

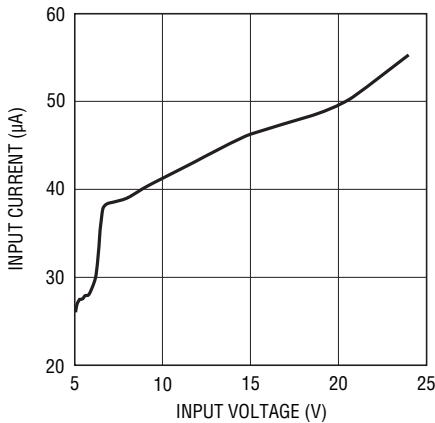

Shutdown Current vs Temperature

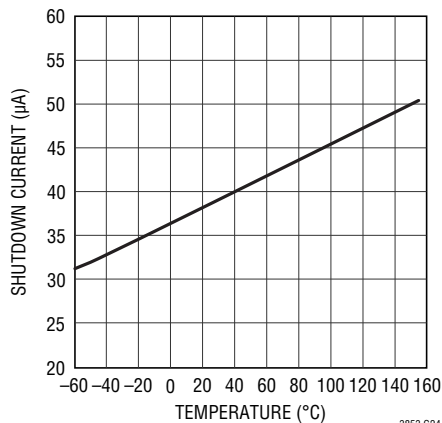

Quiescent Current vs Temperature Without EXT_{V_{CC}}

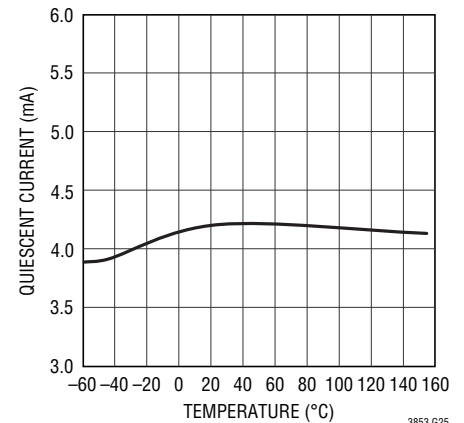

PIN FUNCTIONS

SENSE1⁺, SENSE2⁺, SENSE3⁺ (Pins 3, 5, 7): Current Sense Comparator Inputs. The (+) inputs to the current comparators are normally connected to DCR sensing networks or current sensing resistors. SENSE3⁺ common modes up to 13.5V, allowing higher V_{OUT} voltages on channel 3.

SENSE1⁻, SENSE2⁻, SENSE3⁻ (Pins 4, 6, 8): Current Sense Comparator Inputs. The (-) inputs to the current comparators are connected to the outputs. SENSE3⁻ common modes up to 13.5V, allowing higher V_{OUT} voltages on channel 3.

V_{FB1}, V_{FB2}, V_{FB3} (Pins 9, 12, 14): Error Amplifier Feedback Inputs. These pins receive the remotely sensed feedback voltages for each channel from external resistive dividers across the outputs. Connecting V_{FB2} to V_{IN} through a 200k resistor enables dual output (2 + 1) mode.

I_{TH1}, I_{TH2}, I_{TH3} (Pins 10, 13, 15): Current Control Thresholds and Error Amplifier Compensation Points. Each associated channels' current comparator tripping threshold increases with its I_{TH} control voltage. In dual output (2 + 1) mode, I_{TH1} and I_{TH2} need to be shorted externally.

SGND (Pin 11): Signal Ground. All small-signal components and compensation components should connect to this ground, which in turn connects to PGND at one point.

PGOOD3 (Pin 16): Power Good Indicator Output for Phase 3. Open-drain logic out that is pulled to ground when any channel output exceeds the ±7.5% regulation window, after the internal 17μs power bad mask timer expires.

PGOOD12 (Pin 17): Power Good Indicator Output for Phases 1 and 2. Open-drain logic out that is pulled to ground when any channel output exceeds the ±7.5% regulation window, after the internal 17μs power bad mask timer expires.

INTV_{CC} (Pin 22): Internal 5V Regulator Output. The control circuits are powered from this voltage. Also provides channel 3 driver power. Decouple this pin to PGND with a minimum of 4.7μF low ESR tantalum or ceramic capacitor.

EXTV_{CC} (Pin 23): External Power Input to an Internal Switch Connected to INTV_{CC}. This switch closes and supplies the IC power, bypassing the internal low dropout regulator, whenever EXTV_{CC} is higher than 4.7V. Do not exceed 6V on this pin and ensure V_{IN} > V_{EXTVCC} at all times.

V_{IN} (Pin 24): Main Input Supply. Decouple this pin to PGND with a capacitor (0.1μF to 1μF).

DRV_{CC12} (Pin 29): Driver Voltage Input for Channels 1 and 2. Do not exceed 6V on this pin. This pin must be tied to INTV_{CC} externally.

BG1, BG2, BG3 (Pins 30, 28, 21): Bottom Gate Driver Outputs. These pins drive the gates of the bottom N-channel MOSFETs between PGND and INTV_{CC}/DRV_{CC12}.

SW1, SW2, SW3 (Pins 31, 27, 20): Switch Node Connections to Inductors. Voltage swing at these pins is from a Schottky diode (external) voltage drop below ground to V_{IN}.

TG1, TG2, TG3 (Pins 32, 26, 19): Top Gate Driver Outputs. These are the outputs of floating drivers with a voltage swing equal to INTV_{CC} superimposed on the switch nodes voltages.

BOOST1, BOOST2, BOOST3 (Pins 33, 25, 18): Boosted Floating Driver Supplies. The (+) terminal of the bootstrap capacitors connect to these pins. These pins swing from a diode voltage drop below INTV_{CC} up to V_{IN} + INTV_{CC}.

PIN FUNCTIONS

RUN1, RUN2, RUN3 (Pins 36, 35, 34): Run Control Inputs. A voltage above 1.2V on any RUN pin turns on the IC. However, forcing any of these pins below 1.2V causes the IC to shut down the circuitry required for that particular channel. There are 0.5 μ A pull-up currents for these pins. Once the RUN pin rises above 1.2V, an additional 4.5 μ A pull-up current is added to the pin.

MODE/PLLIN (Pin 37): Force Continuous Mode, Burst Mode, or Pulse Skip Mode Selection Pin and External Synchronization Input to Phase Detector Pin. Connect this pin to SGND to force all channels into the continuous mode of operation. Connect to INTV_{CC} to enable pulse skip mode of operation. Leaving the pin floating will enable Burst Mode operation. A clock on the pin will force the controller into continuous mode of operation and synchronize the internal oscillator.

FREQ/PLLFLTR (Pin 38): The phase-locked loop's low-pass filter is tied to this pin. Alternatively, this pin can be driven with a DC voltage to vary the frequency of the internal oscillator.

I_{LIM} (Pin 39): Current Comparator Sense Voltage Range Inputs. This pin is to be programmed to SGND, FLOAT or INTV_{CC} to set the maximum current sense threshold to three different levels.

TK/SS1, TK/SS2, TK/SS3 (Pins 40, 1, 2): Output Voltage Tracking and Soft-Start Inputs. When one particular channel is configured to be the master, a capacitor to ground at this pin sets the ramp rate for the master channel's output voltage. When the channel is configured to be the slave, the V_{FB} voltage of the master channel is reproduced by a resistor divider and applied to this pin. Internal soft-start currents of 1.3 μ A are charging the soft-start capacitors. In dual output (2 + 1) mode, TK/SS1 and TK/SS2 need to be shorted externally.

PGND (Exposed Pad Pin 41): Power Ground. Connect this pin close to the sources of the bottom N-channel MOSFETs, the (-) terminal of C_{VCC} and the (-) terminal of C_{IN}.

FUNCTIONAL DIAGRAM

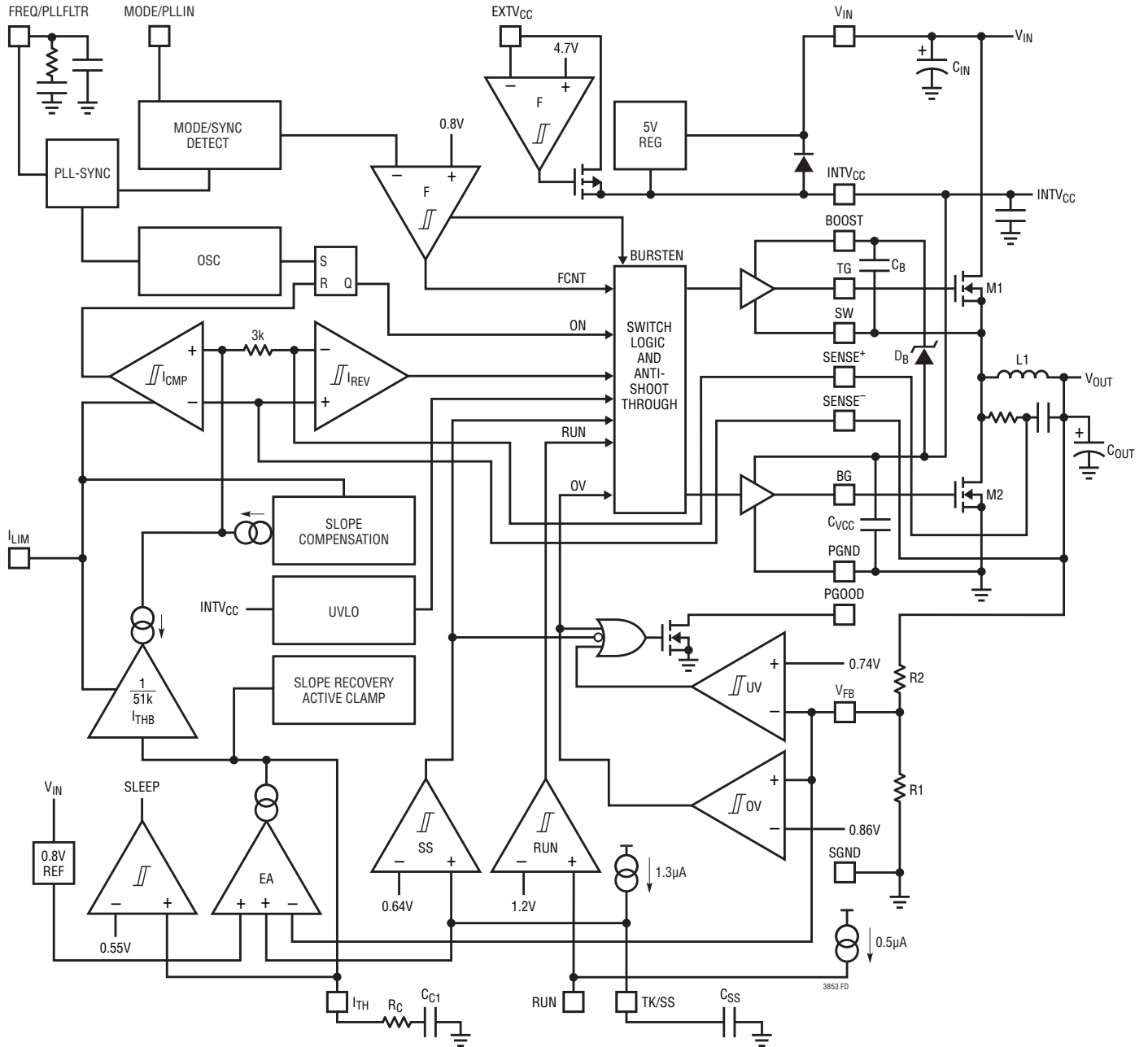

OPERATION

Main Control Loop

The LTC3853 is a constant-frequency, current mode step-down controller with three channels operating 120 degrees out-of-phase. During normal operation, each top MOSFET is turned on when the clock for that channel sets the RS latch, and turned off when the main current comparator, I_{CMP} , resets the RS latch. The peak inductor current at which I_{CMP} resets the RS latch is controlled by the voltage on the I_{TH} pin, which is the output of each error amplifier, EA. The V_{FB} pin receives the voltage feedback signal, which is compared to the internal reference voltage by the EA. When the load current increases, it causes a slight decrease in V_{FB} relative to the 0.8V reference, which in turn causes the I_{TH} voltage to increase until the average inductor current matches the new load current. After the top MOSFET has turned off, the bottom MOSFET is turned on until either the inductor current starts to reverse, as indicated by the reverse current comparator I_{REV} , or the beginning of the next cycle.

INTV_{CC}/EXTV_{CC}/DRV_{CC12} Power

Power for the top and bottom MOSFET drivers of phase 3 and most other internal circuitry is derived from the INTV_{CC} pin. DRV_{CC12} provides driver power for phase 1 and phase 2. This pin must be externally tied to INTV_{CC}. If EXTV_{CC} is taken above 4.7V, the 5V regulator is turned off and an internal switch is turned on connecting EXTV_{CC}. Using the EXTV_{CC} pin allows the INTV_{CC} power to be derived from a high efficiency external source such as one of the LTC3853 switching regulator outputs.

Each top MOSFET driver is biased from the floating bootstrap capacitor, C_B , which normally recharges during each off cycle through an external diode when the top MOSFET turns off. If the input voltage, V_{IN} , decreases to a voltage close to V_{OUT} , the loop may enter dropout and attempt to turn on the top MOSFET continuously. The dropout detector detects this and forces the top MOSFET off for about one-twelfth of the clock period every fifth cycle to allow C_B to recharge. However, it is recommended that there is always a load be present during the dropout transition to ensure C_B is recharged.

Shutdown and Start-Up (RUN1, RUN2, RUN3 and TK/SS1, TK/SS2, TK/SS3 Pins)

The three channels of the LTC3853 can be independently shut down using the RUN1, RUN2 and RUN3 pins. Pulling any of these pins below 1.2V shuts down the main control loop for that controller. Pulling all pins low disables all three controllers and most internal circuits, including the INTV_{CC} regulator. Releasing any RUN pin allows an internal 0.5 μ A current to pull up the pin and enable that controller. Alternatively, the RUN pin may be externally pulled up or driven directly by logic. Be careful not to exceed the absolute maximum rating of 6V on this pin.

The start-up of each controller's output voltage V_{OUT} is controlled by the voltage on the TK/SS1, TK/SS2 and TK/SS3 pins. When the voltage on the TK/SS pin is less than the 0.8V internal reference, the LTC3853 regulates the V_{FB} voltage to the TK/SS pin voltage instead of the 0.8V reference. This allows the TK/SS pin to be used to program a soft-start by connecting an external capacitor from the TK/SS pin to SGND. An internal 1.3 μ A pull-up current charges this capacitor, creating a voltage ramp on the TK/SS pin. As the TK/SS voltage rises linearly from 0V to 0.8V (and beyond), the output voltage V_{OUT} rises smoothly from zero to its final value. Alternatively the TK/SS pin can be used to cause the start-up of V_{OUT} to "track" that of another supply. Typically, this requires connecting to the TK/SS pin an external resistor divider from the other supply to ground (see the Applications Information section). When the corresponding RUN pin is pulled low to disable a controller, or when INTV_{CC} drops below its undervoltage lockout threshold of 3.35V, the TK/SS pin is pulled low by an internal MOSFET. When in undervoltage lockout, all controllers are disabled and the external MOSFETs are held off.

Light Load Current Operation (Burst Mode Operation, Pulse Skipping or Continuous Conduction)

The LTC3853 can be enabled to enter high efficiency Burst Mode operation, constant-frequency pulse skipping mode, or forced continuous conduction mode. To select forced continuous operation, tie the MODE/PLLIN pin to a DC voltage below 0.8V (e.g., SGND). To select pulse skipping

OPERATION

mode of operation, tie the MODE/PLLIN pin to INTV_{CC}. To select Burst Mode operation, float the MODE/PLLIN pin. When the controller is enabled for Burst Mode operation, the peak current in the inductor is set to approximately one-third of the maximum sense voltage even though the voltage on the I_{TH} pin indicates a lower value. If the average inductor current is higher than the load current, the error amplifier EA will decrease the voltage on the I_{TH} pin. When the I_{TH} voltage drops below 0.5V, the internal sleep signal goes high (enabling sleep mode) and both external MOSFETs are turned off.

In sleep mode, the load current is supplied by the output capacitor. As the output voltage decreases, the EA's output begins to rise. When the output voltage drops enough, the sleep signal goes low, and the controller resumes normal operation by turning on the top external MOSFET on the next cycle of the internal oscillator. When the controller is enabled for Burst Mode operation, the inductor current is not allowed to reverse. The reverse current comparator (I_{REV}) turns off the bottom external MOSFET just before the inductor current reaches zero, preventing it from reversing and going negative. Thus, the controller operates in discontinuous operation. In forced continuous operation, the inductor current is allowed to reverse at light loads or under large transient conditions. The peak inductor current is determined by the voltage on the I_{TH} pin, just as in normal operation. In this mode, the efficiency at light loads is lower than in Burst Mode operation. However, continuous mode has the advantages of lower output ripple and less interference with audio circuitry.

When the MODE/PLLIN pin is connected to INTV_{CC}, the LTC3853 operates in PWM pulse skipping mode at light loads. At very light loads, the current comparator, I_{CMP}, may remain tripped for several cycles and force the external top MOSFET to stay off for the same number of cycles (i.e., skipping pulses). The inductor current is not allowed to reverse (discontinuous operation). This mode, like forced continuous operation, exhibits low output ripple as well as low audio noise and reduced RF interference as compared to Burst Mode operation. It provides higher low current efficiency than forced continuous mode, but not nearly as high as Burst Mode operation.

Frequency Selection and Phase-Locked Loop (FREQ/PLLFLTR and MODE/PLLIN Pins)

The selection of switching frequency is a trade-off between efficiency and component size. Low frequency operation increases efficiency by reducing MOSFET switching losses, but requires larger inductance and/or capacitance to maintain low output ripple voltage. The switching frequency of the LTC3853's controllers can be selected using the FREQ/PLLFLTR pin. If the MODE/PLLIN pin is not being driven by an external clock source, the FREQ/PLLFLTR pin can be used to program the controller's operating frequency from 250kHz to 750kHz.

A phase-locked loop (PLL) is available on the LTC3853 to synchronize the internal oscillator to an external clock source that is connected to the MODE/PLLIN pin. The controller is operating in forced continuous mode when it is synchronized. A series R-C should be connected between the FREQ/PLLFLTR pin and SGND to serve as the PLL's loop filter.

Power Good (PGOOD12 and PGOOD3 Pins)

The PGOOD12 pin is connected to an open drain of an internal N-channel MOSFET. The MOSFET turns on and pulls the PGOOD12 pin low when either V_{FB1} or V_{FB2} pin voltage is not within $\pm 7.5\%$ of the 0.8V reference voltage. The PGOOD12 pin is also pulled low when either RUN1 or RUN2 pin is below 1.2V or when the LTC3853 is in the soft-start or tracking phase. When the V_{FB} pin voltage is within the $\pm 7.5\%$ requirement, the MOSFET is turned off and the pin is allowed to be pulled up by an external resistor to a source of up to 6V. The PGOOD12 pin will flag power good immediately when both V_{FB1} and V_{FB2} pins are within the $\pm 7.5\%$ window. However, there is an internal 17 μ s power bad mask when either V_{FB} is out of the $\pm 7.5\%$ window. PGOOD3 monitors V_{FB3} and is also pulled low when RUN3 is below 1.2V.

Output Overvoltage Protection

An overvoltage comparator, OV, guards against transient overshoots ($> 7.5\%$) as well as other more serious conditions that may overvoltage the output. In such cases, the top MOSFET is turned off and the bottom MOSFET is turned on until the overvoltage condition is cleared.

OPERATION

Triple vs Dual (2 + 1) Operation

The LTC3853 can be used to regulate three different outputs. It can also be used as a dual output controller with a high current 2-phase output and a single phase output. Tying V_{FB2} to V_{IN} through a 200k resistor switches the controller from triple to dual (2 + 1) operation. Do not exceed the absolute maximum current rating for the V_{FB2} pin.

In dual (2 + 1) mode, phase 1 and phase 2 are 180 degrees apart (instead of 120 degrees) with phase 3 remaining at

240 degrees from phase 1. The I_{TH1} and I_{TH2} pins must be shorted together externally and so must the TK/SS1 and TK/SS2 pins for proper operating of the 2 phase portion of the controller. RUN2 should be grounded. RUN1 will now control both phases 1 and 2, while RUN3 continues to control the turn on of phase 3.

Phase 3 is also capable of regulating up to a 13.5V output in either mode, while phases 1 and 2 are limited to a 5.3V output.

APPLICATIONS INFORMATION

The Typical Application on the first page is a basic LTC3853 application circuit. LTC3853 can be configured to use either DCR (inductor resistance) sensing or low value resistor sensing. The choice between the two current sensing schemes is largely a design trade-off between cost, power consumption, and accuracy. DCR sensing is becoming popular because it saves expensive current sensing resistors and is more power efficient, especially in high current applications. However, current sensing resistors provide the most accurate current limits for the controller. Other external component selection is driven by the load requirement, and begins with the selection of R_{SENSE} (if R_{SENSE} is used) and inductor value. Next, the power MOSFETs are selected. Finally, input and output capacitors are selected.

Current Limit Programming

The I_{LIM} pin is a tri-level logic input which sets the maximum current limit of the controller. When I_{LIM} is either grounded, floated or tied to $INTV_{CC}$, the typical value for the maximum current sense threshold will be 30mV, 50mV or 75mV, respectively.

Which setting should be used? For the best current limit accuracy, use the 75mV setting. The 30mV setting will allow for the use of very low DCR inductors or sense resistors, but at the expense of current limit accuracy. The 50mV setting is a good balance between the two. For single output dual phase applications ((2 + 1) mode), use the 50mV or 75mV setting for optimal current sharing.

SENSE⁺ and SENSE⁻ Pins

The SENSE⁺ and SENSE⁻ pins are the inputs to the current comparators. The common mode input voltage range of the current comparators is 0V to 5.3V for phases 1 and 2, and 0V to 13.5V for phase 3. Both SENSE pins are high impedance inputs with small base currents of less than 1 μ A. When the SENSE pins ramp up from 0V to 1.4V, the small base currents flow out of the SENSE pins. When the SENSE pins ramp down from the maximum common mode voltage to 1.1V, the small base currents flow into the SENSE pins. The high impedance inputs to the current comparators allow accurate DCR sensing. However, care must be taken not to float these pins during normal operation.

Filter components mutual to the sense lines should be placed close to the LTC3853, and the sense lines should run close together to a Kelvin connection underneath the current sense element (shown in Figure 1). Sensing current elsewhere can effectively add parasitic inductance and capacitance to the current sense element, degrading

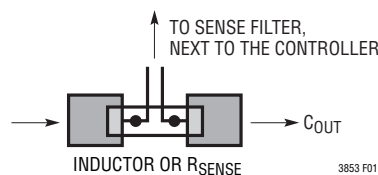
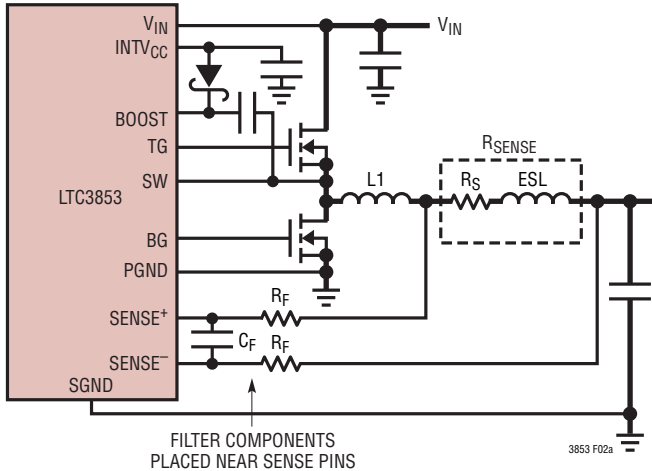

Figure 1. Sense Lines Placement with Inductor or Sense Resistor

APPLICATIONS INFORMATION

the information at the sense terminals and making the programmed current limit unpredictable. If DCR sensing is used (Figure 2b), sense resistor R1 should be placed close to the switching node, to prevent noise from coupling into sensitive small-signal nodes. The capacitor C1 should be placed close to the IC pins.



(2a) Using a Resistor to Sense Current

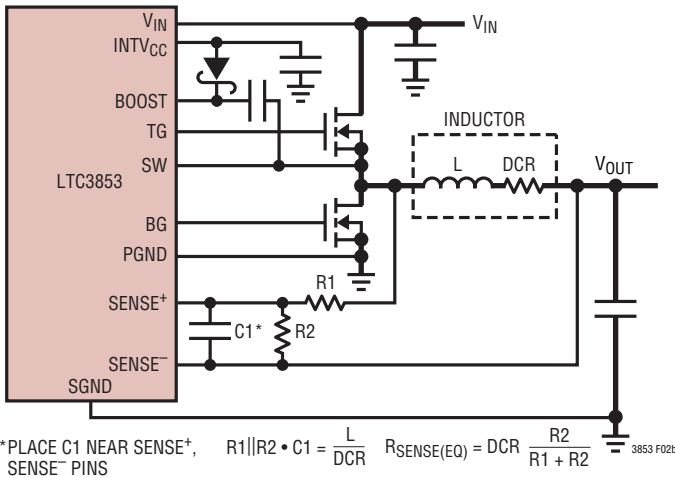

* PLACE C1 NEAR SENSE+, SENSE- PINS

$$R1 || R2 \cdot C1 = \frac{L}{DCR} \quad R_{SENSE(EQ)} = DCR \frac{R2}{R1 + R2}$$

(2b) Using the Inductor DCR to Sense Current

Figure 2. Two Different Methods of Sensing Current

Low Value Resistors Current Sensing

A typical sensing circuit using a discrete resistor is shown in Figure 2a. R_{SENSE} is chosen based on the required output current.

The current comparator has a maximum threshold $V_{SENSE(MAX)}$ determined by the I_{LIM} setting. The current comparator threshold sets the peak of the inductor current, yielding a maximum average output current I_{MAX} equal to the peak value less half the peak-to-peak ripple current, ΔI_L . To calculate the sense resistor value, use the equation:

$$R_{SENSE} = \frac{V_{SENSE(MAX)}}{I_{(MAX)} + \frac{\Delta I_L}{2}}$$

Because of possible PCB noise in the current sensing loop, the AC current sensing ripple of $\Delta V_{SENSE} = \Delta I_L \cdot R_{SENSE}$ also needs to be checked in the design to get a good signal-to-noise ratio. In general, for a reasonably good PCB layout, a 15mV ΔV_{SENSE} voltage is recommended as a conservative number to start with, either for R_{SENSE} or DCR sensing applications.

For previous generation current mode controllers, the maximum sense voltage was high enough (e.g., 75mV for the LTC1628/LTC3728 family) that the voltage drop across the parasitic inductance of the sense resistor represented a relatively small error. For today's highest current density solutions, however, the value of the sense resistor can be less than 1mΩ and the peak sense voltage can be as low as 20mV. In addition, inductor ripple currents greater than 50% with operation up to 1MHz are becoming more common. Under these conditions the voltage drop across the sense resistor's parasitic inductance is no longer negligible. A typical sensing circuit using a discrete resistor is shown in Figure 2a. In previous generations of controllers, a small RC filter placed near the IC was commonly used to reduce the effects of capacitive and inductive noise coupled in the sense traces on the PCB. A typical filter consists of two series 10Ω resistors connected to a parallel 1000pF capacitor, resulting in a time constant of 20ns.

This same RC filter, with minor modifications, can be used to extract the resistive component of the current sense signal in the presence of parasitic inductance.

APPLICATIONS INFORMATION

For example, Figure 3 illustrates the voltage waveform across a 2mΩ sense resistor with a 2010 footprint for the 1.2V/15A converter operating at 100% load. The waveform is the superposition of a purely resistive component and a purely inductive component. It was measured using two scope probes and waveform math to obtain a differential measurement. Based on additional measurements of the inductor ripple current and the on-time and off-time of the top switch, the value of the parasitic inductance was determined to be 0.5nH using the equation:

$$ESL = \frac{V_{ESL(STEP)} \cdot t_{ON} \cdot t_{OFF}}{\Delta I_L \cdot (t_{ON} + t_{OFF})}$$

If the RC time constant is chosen to be close to the parasitic inductance divided by the sense resistor (L/R), the resulting waveform looks resistive again, as shown in Figure 4. For applications using low maximum sense voltages, check the sense resistor manufacturer's data sheet for information about parasitic inductance. In the absence of

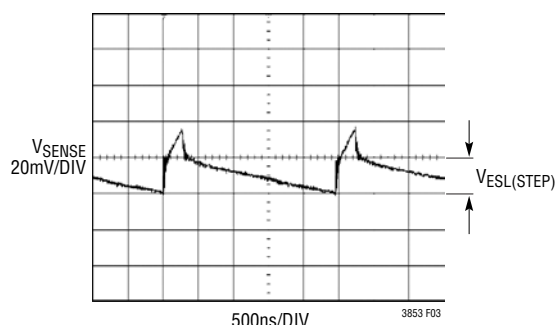

Figure 3. Voltage Waveform Measured Directly Across The Sense Resistor

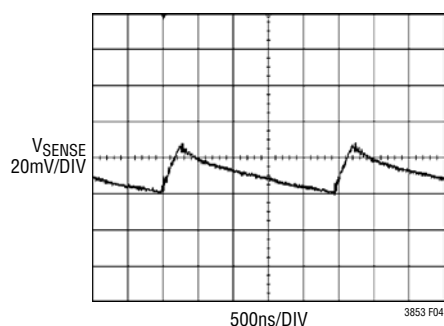

Figure 4. Voltage Waveform Measured After the Sense Resistor Filter. C_F = 1000pF, R_F = 100Ω

data, measure the voltage drop directly across the sense resistor to extract the magnitude of the ESL step and use the equation above to determine the ESL. However, do not over-filter. Keep the RC time constant less than or equal to the inductor time constant to maintain a high enough ripple voltage on V_{RSENSE}.

The above generally applies to high density/high current applications where I_(MAX) > 10A and low values of inductors are used. For applications where I_(MAX) < 10A, set R_F to 10Ω and C_F to 1000pF. This will provide a good starting point.

The filter components need to be placed close to the IC. The positive and negative sense traces need to be routed as a differential pair and Kelvin connected to the sense resistor.

Inductor DCR Sensing

For applications requiring the highest possible efficiency at high load currents, the LTC3853 is capable of sensing the voltage drop across the inductor DCR, as shown in Figure 2b. The DCR of the inductor represents the small amount of DC winding resistance of the copper, which can be less than 1mΩ for today's low value, high current inductors. In a high current application requiring such an inductor, conduction loss through a sense resistor would cost several points of efficiency compared to DCR sensing.

If the external R1||R2 • C1 time constant is chosen to be exactly equal to the L/DCR time constant, the voltage drop across the external capacitor is equal to the drop across the inductor DCR multiplied by R2/(R1 + R2). R2 scales the voltage across the sense terminals for applications where the DCR is greater than the target sense resistor value. To properly dimension the external filter components, the DCR of the inductor must be known. It can be measured using a good RLC meter, but the DCR tolerance is not always the same and varies with temperature; consult the manufacturers' data sheets for detailed information.

Using the inductor ripple current value from the Inductor Value Calculation section, the target sense resistor value is:

$$R_{SENSE(EQUIV)} = \frac{V_{SENSE(MAX)}}{I_{(MAX)} + \frac{\Delta I_L}{2}}$$

APPLICATIONS INFORMATION

To ensure that the application will deliver full load current over the full operating temperature range, choose the minimum value for the Maximum Current Sense Threshold ($V_{SENSE(MAX)}$) in the Electrical Characteristics table (22mV, 42mV, or 65mV, depending on the state of the I_{LIM} pin).

Next, determine the DCR of the inductor. Where provided, use the manufacturer's maximum value, usually given at 20°C. Increase this value to account for the temperature coefficient of resistance, which is approximately 0.4%/°C. A conservative value for $T_{L(MAX)}$ is 100°C.

To scale the maximum inductor DCR to the desired sense resistor value, use the divider ratio:

$$R_D = \frac{R_{SENSE(EQUIV)}}{DCR_{(MAX)} \text{ at } T_{L(MAX)}}$$

C1 is usually selected to be in the range of 0.047μF to 0.47μF. This forces $R1||R2$ to around 2kΩ, reducing error that might have been caused by the SENSE pins' ±1μA current.

The equivalent resistance $R1||R2$ is scaled to the room temperature inductance and maximum DCR:

$$R1||R2 = \frac{L}{(DCR \text{ at } 20^\circ\text{C}) \cdot C1}$$

The sense resistor values are:

$$R1 = \frac{R1||R2}{R_D}; \quad R2 = \frac{R1 \cdot R_D}{1 - R_D}$$

The maximum power loss in R1 is related to duty cycle, and will occur in continuous mode at the maximum input voltage:

$$P_{LOSS \ R1} = \frac{(V_{IN(MAX)} - V_{OUT}) \cdot V_{OUT}}{R1}$$

Ensure that R1 has a power rating higher than this value. If high efficiency is necessary at light loads, consider this power loss when deciding whether to use DCR sensing or sense resistors. Light load power loss can be modestly higher with a DCR network than with a sense resistor, due to the extra switching losses incurred through R1.

However, DCR sensing eliminates a sense resistor, reduces conduction losses and provides higher efficiency at heavy loads. Peak efficiency is about the same with either method. To maintain a good signal-to-noise ratio for the current sense signal, use a minimum ΔV_{SENSE} of 10mV to 15mV. For a DCR sensing application, the actual ripple voltage will be determined by:

$$\Delta V_{SENSE} = \frac{V_{IN} - V_{OUT}}{R1 \cdot C1} \cdot \frac{V_{OUT}}{V_{IN} \cdot f_{OSC}}$$

Slope Compensation and Inductor Peak Current

Slope compensation provides stability in constant-frequency architectures by preventing subharmonic oscillations at high duty cycles. It is accomplished internally by adding a compensating ramp to the inductor current signal at duty cycles in excess of 40%. Normally, this results in a reduction of maximum inductor peak current for duty cycles >40%. However, the LTC3853 uses a patented scheme that counteracts this compensating ramp, which allows the maximum inductor peak current to remain unaffected throughout all duty cycles.

Inductor Value Calculation

Given the desired input and output voltages, the inductor value and operating frequency, f_{OSC} , directly determine the inductor's peak-to-peak ripple current:

$$I_{RIPPLE} = \frac{V_{OUT}}{V_{IN}} \left(\frac{V_{IN} - V_{OUT}}{f_{OSC} \cdot L} \right)$$

Lower ripple current reduces core losses in the inductor, ESR losses in the output capacitors, and output voltage ripple. Thus, highest efficiency operation is obtained at low frequency with a small ripple current. Achieving this, however, requires a large inductor.

A reasonable starting point is to choose a ripple current that is about 40% of $I_{OUT(MAX)}$. Note that the largest ripple current occurs at the highest input voltage. To guarantee that ripple current does not exceed a specified maximum, the inductor should be chosen according to:

$$L \geq \frac{V_{IN} - V_{OUT}}{f_{OSC} \cdot I_{RIPPLE}} \cdot \frac{V_{OUT}}{V_{IN}}$$

APPLICATIONS INFORMATION

Inductor Core Selection

Once the inductance value is determined, the type of inductor must be selected. Core loss is independent of core size for a fixed inductor value, but it is very dependent on inductance selected. As inductance increases, core losses go down. Unfortunately, increased inductance requires more turns of wire and therefore copper losses will increase.

Ferrite designs have very low core loss and are preferred at high switching frequencies, so design goals can concentrate on copper loss and preventing saturation. Ferrite core material saturates “hard,” which means that inductance collapses abruptly when the peak design current is exceeded. This results in an abrupt increase in inductor ripple current and consequent output voltage ripple. Do not allow the core to saturate!

Power MOSFET and Schottky Diode (Optional) Selection

Two external power MOSFETs must be selected for each controller in the LTC3853: one N-channel MOSFET for the top (main) switch, and one N-channel MOSFET for the bottom (synchronous) switch.

The peak-to-peak drive levels are set by the $INTV_{CC}/DRV_{CC12}$ voltage. This voltage is typically 5V during start-up (see $EXTV_{CC}$ Pin Connection). Consequently, logic-level threshold MOSFETs must be used in most applications. The only exception is if low input voltage is expected ($V_{IN} < 5V$); then, sub-logic level threshold MOSFETs ($V_{GS(TH)} < 3V$) should be used. Pay close attention to the BV_{DSS} specification for the MOSFETs as well; most of the logic level MOSFETs are limited to 30V or less.

Selection criteria for the power MOSFETs include the on-resistance, $R_{DS(ON)}$, Miller capacitance, C_{MILLER} , input voltage and maximum output current. Miller capacitance, C_{MILLER} , can be approximated from the gate charge curve usually provided on the MOSFET manufacturers’ data sheet. C_{MILLER} is equal to the increase in gate charge along the horizontal axis while the curve is approximately flat divided by the specified change in V_{DS} . This result is then multiplied by the ratio of the application applied V_{DS} to the gate charge curve specified V_{DS} . When the IC is

operating in continuous mode the duty cycles for the top and bottom MOSFETs are given by:

$$\text{Main Switch Duty Cycle} = \frac{V_{OUT}}{V_{IN}}$$

$$\text{Synchronous Switch Duty Cycle} = \frac{V_{IN} - V_{OUT}}{V_{IN}}$$

The MOSFET power dissipations at maximum output current are given by:

$$P_{MAIN} = \frac{V_{OUT}}{V_{IN}} (I_{MAX})^2 (1 + \delta) R_{DS(ON)} + (V_{IN})^2 \left(\frac{I_{MAX}}{2} \right) (R_{DR}) (C_{MILLER}) \cdot \left[\frac{1}{V_{INTVCC} - V_{TH(MIN)}} + \frac{1}{V_{TH(MIN)}} \right] \cdot f_{OSC}$$

$$P_{SYNC} = \frac{V_{IN} - V_{OUT}}{V_{IN}} (I_{MAX})^2 (1 + \delta) R_{DS(ON)}$$

where δ is the temperature dependency of $R_{DS(ON)}$ and R_{DR} (approximately 2Ω) is the effective driver resistance at the MOSFET’s Miller threshold voltage. $V_{TH(MIN)}$ is the typical MOSFET minimum threshold voltage.

Both MOSFETs have I^2R losses while the topside N-channel equation includes an additional term for transition losses, which are highest at high input voltages. For $V_{IN} < 20V$ the high current efficiency generally improves with larger MOSFETs, while for $V_{IN} > 20V$ the transition losses rapidly increase to the point that the use of a higher $R_{DS(ON)}$ device with lower C_{MILLER} actually provides higher efficiency. The synchronous MOSFET losses are greatest at high input voltage when the top switch duty factor is low or during a short-circuit when the synchronous switch is on close to 100% of the period.

The term $(1 + \delta)$ is generally given for a MOSFET in the form of a normalized $R_{DS(ON)}$ vs Temperature curve, but $\delta = 0.005/^\circ C$ can be used as an approximation for low voltage MOSFETs.

APPLICATIONS INFORMATION

The optional Schottky diodes conduct during the dead time between the conduction of the two power MOSFETs. These prevent the body diodes of the bottom MOSFETs from turning on, storing charge during the dead time and requiring a reverse recovery period that could cost as much as 3% in efficiency at high V_{IN} . A 1A to 3A Schottky is generally a good compromise for both regions of operation due to the relatively small average current. Larger diodes result in additional transition losses due to their larger junction capacitance.

Soft-Start and Tracking

The LTC3853 has the ability to either soft-start by itself with a capacitor or track the output of another channel or external supply. When one particular channel is configured to soft-start by itself, a capacitor should be connected to its TK/SS pin. This channel is in the shutdown state if its RUN pin voltage is below 1.2V. Its TK/SS pin is actively pulled to ground in this shutdown state.

Once the RUN pin voltage is above 1.2V, the channel powers up. A soft-start current of 1.3 μ A then starts to charge its soft-start capacitor. Note that soft-start or tracking is achieved not by limiting the maximum output current of the controller but by controlling the output ramp voltage according to the ramp rate on the TK/SS pin. Current foldback is disabled during this phase to ensure smooth soft-start or tracking. The soft-start or tracking range is defined to be the voltage range from 0V to 0.8V on the TK/SS pin. The total soft-start time can be calculated as:

$$t_{\text{SOFTSTART}} = 0.8 \cdot \frac{C_{\text{SS}}}{1.3\mu\text{A}}$$

Regardless of the mode selected by the MODE/PLLIN pin, the regulator will always start in pulse skipping mode up to TK/SS = 0.64V. Between TK/SS = 0.64V and 0.74V, it will operate in forced continuous mode and revert to the selected mode once TK/SS > 0.74V. The output ripple is minimized during the 100mV forced continuous mode window ensuring a clean PGOOD signal.

When the channel is configured to track another supply, the feedback voltage of the other supply is duplicated by a resistor divider and applied to the TK/SS pin. Therefore, the voltage ramp rate on this pin is determined by the

ramp rate of the other supply's voltage. Note that the small soft-start capacitor charging current is always flowing, producing a small offset error. To minimize this error, select the tracking resistive divider value to be small enough to make this error negligible.

In order to track down another channel or supply after the soft-start phase expires, the LTC3853 is forced into continuous mode of operation as soon as V_{FB} is below the undervoltage threshold of 0.74V regardless of the setting of the MODE/PLLIN pin. However, the LTC3853 should always be set in force continuous mode tracking down when there is no load. After TK/SS drops below 0.1V, its channel will operate in discontinuous mode.

Output Voltage Tracking

The LTC3853 allows the user to program how its output ramps up and down by means of the TK/SS pins. Through these pins, the output can be set up to either coincidentally or ratiometrically track another supply's output, as shown in Figure 5. In the following discussions, V_{OUT1} refers to the LTC3853's output 1 as a master channel and V_{OUT2} refers to the LTC3853's output 2 as a slave channel. In practice though, any phase can be used as the master. To implement the coincident tracking in Figure 5a, connect an additional resistive divider to V_{OUT1} and connect its midpoint to the TK/SS pin of the slave channel. The ratio of this divider should be the same as that of the slave channel's feedback divider shown in Figure 6a. In this tracking mode, V_{OUT1} must be set higher than V_{OUT2} . To implement the ratiometric tracking, the ratio of the slave's divider should be exactly the same as the master channel's feedback divider. By selecting different resistors, the LTC3853 can achieve different modes of tracking including the two in Figure 5.

So which mode should be programmed? While either mode in Figure 6 satisfies most practical applications, there are some trade-offs. The ratiometric mode saves a pair of resistors, but the coincident mode offers better output regulation. This can be better understood with the help of Figure 7. At the input stage of the slave channel's error amplifier, two common anode diodes are used to clamp the equivalent reference voltage and an additional diode is used to match the shifted common mode voltage. The top two current sources are of the same amplitude. In the

3853fc

APPLICATIONS INFORMATION

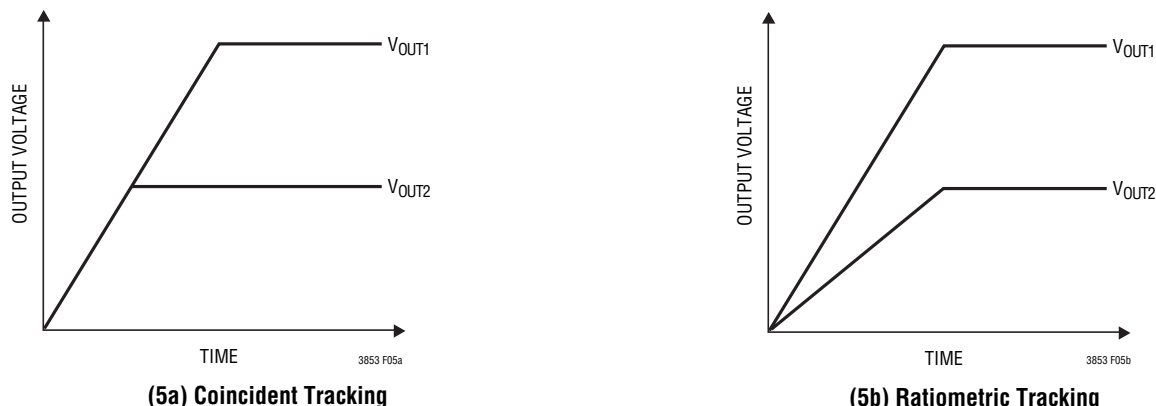

Figure 5. Two Different Modes of Output Voltage Tracking

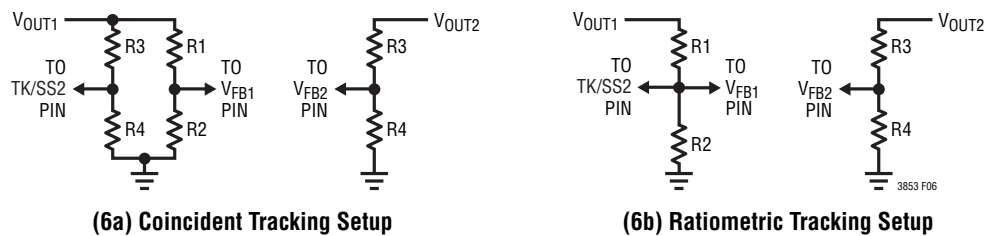

Figure 6. Setup for Coincident and Ratiometric Tracking

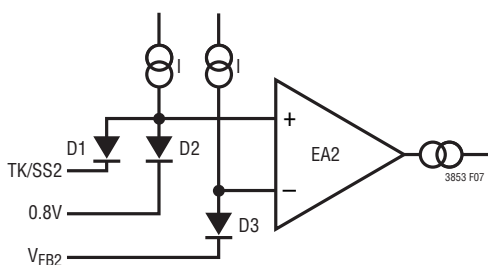

Figure 7. Equivalent Input Circuit of Error Amplifier

coincident mode, the TK/SS voltage is substantially higher than 0.8V at steady state and effectively turns off D1. D2 and D3 will therefore conduct the same current and offer tight matching between V_{FB2} and the internal precision 0.8V reference. In the ratiometric mode, however, TK/SS equals 0.8V at steady state. D1 will divert part of the bias current to make V_{FB2} slightly lower than 0.8V.

Although this error is minimized by the exponential I-V characteristic of the diode, it does impose a finite amount

of output voltage deviation. Furthermore, when the master channel's output experiences dynamic excursion (under load transient, for example), the slave channel output will be affected as well. For better output regulation, use the coincident tracking mode instead of ratiometric.

INTV_{CC} Regulators and EXTV_{CC}

The LTC3853 features an NPN linear regulator that supplies power to INTV_{CC} from the V_{IN} supply. INTV_{CC} powers the gate drivers and much of the LTC3853's internal circuitry. The linear regulator regulates the voltage at the INTV_{CC} pin to 5V when V_{IN} is greater than 6.5V. EXTV_{CC} connects to INTV_{CC} through a P-channel MOSFET and can supply the needed power when its voltage is higher than 4.7V. Each of these can supply a peak current of 150mA and must be bypassed to ground with a minimum of 1 μ F ceramic capacitor or low ESR electrolytic capacitor. No matter what type of bulk capacitor is used, an additional 0.1 μ F ceramic capacitor placed directly adjacent to the INTV_{CC} and PGND pins is highly recommended. Good bypassing

3853fc

APPLICATIONS INFORMATION

is needed to supply the high transient currents required by the MOSFET gate drivers and to prevent interaction between the channels.

High input voltage applications in which large MOSFETs are being driven at high frequencies may cause the maximum junction temperature rating for the LTC3853 to be exceeded. The $INTV_{CC}$ current, which is dominated by the gate charge current, may be supplied by either the 5V linear regulator or $EXTV_{CC}$. When the voltage on the $EXTV_{CC}$ pin is less than 4.7V, the linear regulator is enabled. Power dissipation for the IC in this case is highest and is equal to $V_{IN} \cdot I_{INTV_{CC}}$. The gate charge current is dependent on operating frequency as discussed in the Efficiency Considerations section. The junction temperature can be estimated by using the equations given in Note 3 of the Electrical Characteristics. For example, the LTC3853 $INTV_{CC}$ current is limited to less than 50mA from a 24V supply in the UJ package and not using the $EXTV_{CC}$ supply:

$$T_J = 85^\circ\text{C} + (50\text{mA})(24\text{V})(33^\circ\text{C/W}) = 125^\circ\text{C}$$

To prevent the maximum junction temperature from being exceeded, the input supply current must be checked while operating in continuous conduction mode (MODE/PLLIN = SGND) at maximum V_{IN} . When the voltage applied to $EXTV_{CC}$ rises above 4.7V, the $INTV_{CC}$ linear regulator is turned off and the $EXTV_{CC}$ is connected to the $INTV_{CC}$. The $EXTV_{CC}$ remains on as long as the voltage applied to $EXTV_{CC}$ remains above 4.5V. Using the $EXTV_{CC}$ allows the MOSFET driver and control power to be derived from one of the LTC3853's switching regulator outputs during normal operation and from the $INTV_{CC}$ when the output is out of regulation (e.g., start-up, short-circuit). If more current is required through the $EXTV_{CC}$ than is specified, an external Schottky diode can be added between the $EXTV_{CC}$ and $INTV_{CC}$ pins. Do not apply more than 6V to the $EXTV_{CC}$ pin and make sure that $EXTV_{CC} < V_{IN}$.

Significant efficiency and thermal gains can be realized by powering $INTV_{CC}$ from the output, since the V_{IN} current resulting from the driver and control currents will be scaled by a factor of (Duty Cycle)/(Switcher Efficiency).

Tying the $EXTV_{CC}$ pin to a 5V supply reduces the junction temperature in the previous example from 125°C to:

$$T_J = 85^\circ\text{C} + (50\text{mA})(5\text{V})(33^\circ\text{C/W}) = 94^\circ\text{C}$$

However, for 3.3V and other low voltage outputs, additional circuitry is required to derive $INTV_{CC}$ power from the output.

The following list summarizes the four possible connections for $EXTV_{CC}$:

1. $EXTV_{CC}$ left open (or grounded). This will cause $INTV_{CC}$ to be powered from the internal 5V regulator resulting in an efficiency penalty of up to 10% at high input voltages.
2. $EXTV_{CC}$ connected directly to V_{OUT} . This is the normal connection for a 5V regulator and provides the highest efficiency.
3. $EXTV_{CC}$ connected to an external supply. If a 5V external supply is available, it may be used to power $EXTV_{CC}$ providing it is compatible with the MOSFET gate drive requirements.
4. $EXTV_{CC}$ connected to an output-derived boost network. For 3.3V and other low voltage regulators, efficiency gains can still be realized by connecting $EXTV_{CC}$ to an output-derived voltage that has been boosted to greater than 4.7V.

For applications where the main input power is 5V, tie the V_{IN} and $INTV_{CC}$ pins together and tie the combined pins to the 5V input with a 1Ω or 2.2Ω resistor as shown in Figure 8 to minimize the voltage drop caused by the gate charge current. This will override the $INTV_{CC}$ linear regulator and will prevent $INTV_{CC}$ from dropping too low due to the dropout voltage. Make sure the $INTV_{CC}$ voltage is at or exceeds the $R_{DS(ON)}$ test voltage for the MOSFET which is typically 4.5V for logic-level devices.

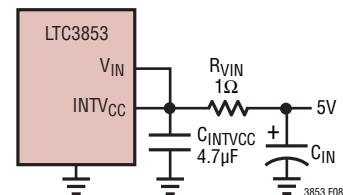

Figure 8. Setup for a 5V Input

APPLICATIONS INFORMATION

Topside MOSFET Driver Supply (C_B , D_B)

External bootstrap capacitors, C_B , connected to the BOOST pins supply the gate drive voltages for the topside MOSFETs. Capacitor C_B in the Functional Diagram is charged through external diode, D_B , from $INTV_{CC}$ when the SW pin is low. When one of the topside MOSFETs is to be turned on, the driver places the C_B voltage across the gate source of the desired MOSFET. This enhances the MOSFET and turns on the topside switch. The switch node voltage, SW, rises to V_{IN} and the BOOST pin follows. With the topside MOSFET on, the boost voltage is above the input supply: $V_{BOOST} = V_{IN} + V_{INTV_{CC}}$. The value of the boost capacitor, C_B , needs to be 100 times that of the total input capacitance of the topside MOSFET(s). The reverse breakdown of the external Schottky diode must be greater than $V_{IN(MAX)}$. When adjusting the gate drive level, the final arbiter is the total input current for the regulator. If a change is made and the input current decreases, then the efficiency has improved. If there is no change in input current, then there is no change in efficiency.

Undervoltage Lockout

The LTC3853 has two functions that help protect the controller in case of undervoltage conditions. A precision UVLO comparator constantly monitors the $INTV_{CC}$ voltage to ensure that an adequate gate-drive voltage is present. It locks out the switching action when $INTV_{CC}$ is below 3.35V. To prevent oscillation when there is a disturbance on the $INTV_{CC}$, the UVLO comparator has 500mV of precision hysteresis.

Another way to detect an undervoltage condition is to monitor the V_{IN} supply. Because the RUN pins have a precision turn-on reference of 1.2V, one can use a resistor divider to V_{IN} to turn on the IC when V_{IN} is high enough. An extra 4.5 μ A of current flows out of the RUN pin once the RUN pin voltage passes 1.2V. One can program the hysteresis of the run comparator by adjusting the values of the resistive divider. For accurate V_{IN} undervoltage detection using the RUN pin, V_{IN} needs to be higher than 4V.

C_{IN} and C_{OUT} Selection

The selection of C_{IN} is simplified by the 3-phase architecture and its impact on the worst-case RMS current drawn through the input network (battery/fuse/capacitor). It can be shown that the worst-case capacitor RMS current occurs when only one controller is operating. The controller with the highest $(V_{OUT})(I_{OUT})$ product needs to be used in the formula below to determine the maximum RMS capacitor current requirement. Increasing the output current drawn from the other controllers will actually decrease the input RMS ripple current from its maximum value. The out-of-phase technique typically reduces the input capacitor's RMS ripple current by a factor of 30% to 70% when compared to a single phase power supply solution.

In continuous mode, the source current of the top MOSFET is a square wave of duty cycle $(V_{OUT})/(V_{IN})$. To prevent large voltage transients, a low ESR capacitor sized for the maximum RMS current of one channel must be used. The maximum RMS capacitor current is given by:

$$C_{IN} \text{ Required } I_{RMS} \approx \frac{I_{MAX}}{V_{IN}} [(V_{OUT})(V_{IN} - V_{OUT})]^{1/2}$$

This formula has a maximum at $V_{IN} = 2V_{OUT}$, where $I_{RMS} = I_{OUT}/2$. This simple worst-case condition is commonly used for design because even significant deviations do not offer much relief. Note that capacitor manufacturers' ripple current ratings are often based on only 2000 hours of life. This makes it advisable to further derate the capacitor, or to choose a capacitor rated at a higher temperature than required. Several capacitors may be paralleled to meet size or height requirements in the design. Due to the high operating frequency of the LTC3853, ceramic capacitors can also be used for C_{IN} . Always consult the manufacturer if there is any question.

The benefit of the LTC3853 3-phase operation can be calculated by using the equation above for the higher power controller and then calculating the loss that would have resulted if all controller channels switched on at the same time. The total RMS power lost is lower when more than one controller is operating due to the reduced overlap of current pulses required through the input capacitor's ESR. This is why the input capacitor's requirement calculated above for the worst-case controller is adequate for the

3853fc

APPLICATIONS INFORMATION

dual or triple controller design. Also, the input protection fuse resistance, battery resistance, and PC board trace resistance losses are also reduced due to the reduced peak currents in a 3-phase system. The overall benefit of a multiphase design will only be fully realized when the source impedance of the power supply/battery is included in the efficiency testing. The sources of the top MOSFETs should be placed within 1cm of each other and share a common $C_{IN}(s)$. Separating the sources and C_{IN} may produce undesirable voltage and current resonances at V_{IN} .

A small (0.1 μ F to 1 μ F) bypass capacitor between the chip V_{IN} pin and ground, placed close to the LTC3853, is also suggested. A 2.2 Ω to 10 Ω resistor placed between C_{IN} and the V_{IN} pin provides further isolation between the channels.

The selection of C_{OUT} is driven by the effective series resistance (ESR). Typically, once the ESR requirement is satisfied, the capacitance is adequate for filtering. The output ripple (ΔV_{OUT}) is approximated by:

$$\Delta V_{OUT} \approx I_{RIPPLE} \left(ESR + \frac{1}{8fC_{OUT}} \right)$$

where f is the operating frequency, C_{OUT} is the output capacitance and I_{RIPPLE} is the ripple current in the inductor. The output ripple is highest at maximum input voltage since I_{RIPPLE} increases with input voltage.

Setting Output Voltage

The LTC3853 output voltages are each set by an external feedback resistive divider carefully placed across the output, as shown in Figure 9. The regulated output voltage is determined by:

$$V_{OUT} = 0.8V \cdot \left(1 + \frac{R_B}{R_A} \right)$$

To improve the frequency response, a feed-forward capacitor, C_{FF} , may be used. Great care should be taken to route the V_{FB} line away from noise sources, such as the inductor or the SW line.

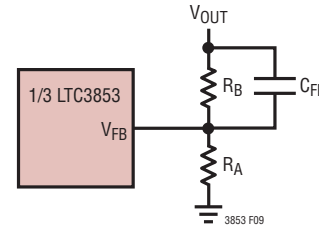

Figure 9. Setting Output Voltage

Fault Conditions: Current Limit and Current Foldback

The LTC3853 includes current foldback to help limit load current when the output is shorted to ground. If the output falls below 50% of its nominal output level, then the maximum sense voltage is progressively lowered from its maximum programmed value to one-third of the maximum value. Foldback current limiting is disabled during the soft-start or tracking up. Under short-circuit conditions with very low duty cycles, the LTC3853 will begin cycle skipping in order to limit the short-circuit current. In this situation the bottom MOSFET will be dissipating most of the power but less than in normal operation. The short-circuit ripple current is determined by the minimum on-time $t_{ON(MIN)}$ of the LTC3853 (≈ 90 ns), the input voltage and inductor value:

$$\Delta I_{L(SC)} = t_{ON(MIN)} \cdot \frac{V_{IN}}{L}$$

The resulting short-circuit current is:

$$I_{SC} = \frac{1/3 V_{SENSE(MAX)}}{R_{SENSE}} - \frac{1}{2} \Delta I_{L(SC)}$$

APPLICATIONS INFORMATION

Phase-Locked Loop and Frequency Synchronization

The LTC3853 has a phase-locked loop (PLL) comprised of an internal voltage-controlled oscillator (VCO) and a phase detector. This allows the turn-on of the top MOSFET of controller 1 to be locked to the rising edge of an external clock signal applied to the MODE/PLLIN pin. The phase detector is an edge sensitive digital type that provides zero degrees phase shift between the external and internal oscillators. This type of phase detector does not exhibit false lock to harmonics of the external clock.

The output of the phase detector is a pair of complementary current sources that charge or discharge the external filter network connected to the FREQ/PLLFLTR pin. The relationship between the voltage on the FREQ/PLLFLTR pin and operating frequency is shown in Figure 10 and specified in the Electrical Characteristics table. Note that the LTC3853 can only be synchronized to an external clock whose frequency is within range of the LTC3853's internal V_{CO} . This is guaranteed to be between 250kHz and 750kHz. A simplified block diagram is shown in Figure 11.

If the external clock frequency is greater than the internal oscillator's frequency, f_{OSC} , or if the external clock's phase lags the internal oscillator, then current is sourced from the phase detector output, pulling up the FREQ/PLLFLTR pin. When the external clock frequency is less than f_{OSC} , or if the external clock's phase leads the internal oscillator, current is sunk, pulling down the FREQ/PLLFLTR pin. The voltage on the FREQ/PLLFLTR pin is adjusted until the

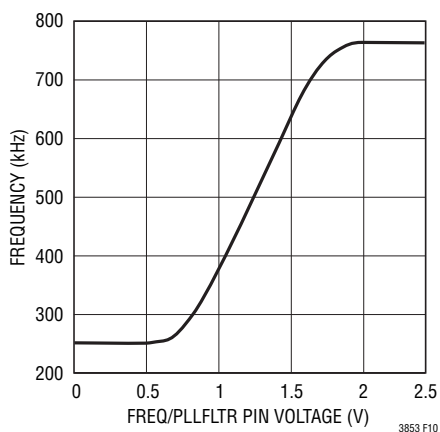

Figure 10. Relationship Between Oscillator Frequency and Voltage at the FREQ/PLLFLTR Pin

phase and frequency of the internal and external oscillators are identical. At the stable operating point, the phase detector output is high impedance and the filter capacitor, C_{LP} , holds the voltage.

The loop filter components, C_{LP} and R_{LP} , smooth out the current pulses from the phase detector and provide a stable input to the voltage-controlled oscillator. The filter components C_{LP} and R_{LP} determine how fast the loop acquires lock. Typically $R_{LP} = 10k$ and C_{LP} is 2200pF or 0.01 μ F.

Typically, the external clock (on MODE/PLLIN pin) input high threshold is 1.6V, while the input low threshold is 1V.

Minimum On-Time Considerations

Minimum on-time $t_{ON(MIN)}$ is the smallest time duration that the LTC3853 is capable of turning on the top MOSFET. It is determined by internal timing delays and the gate charge required to turn on the top MOSFET. Low duty cycle applications may approach this minimum on-time limit and care should be taken to ensure that

$$t_{ON(MIN)} < \frac{V_{OUT}}{V_{IN}(f)}$$

If the duty cycle falls below what can be accommodated by the minimum on-time, the controller will begin to skip cycles. The output voltage will continue to be regulated, but the ripple voltage and current will increase.

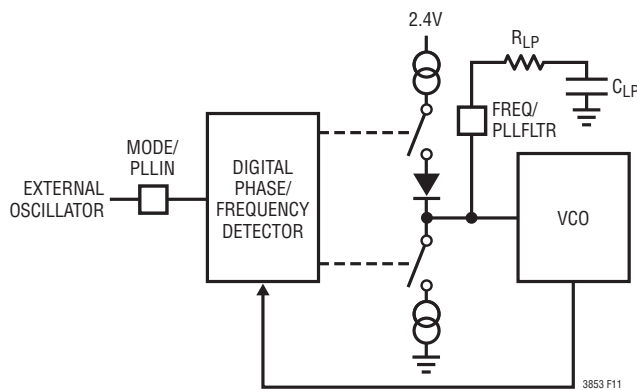

Figure 11. Phase-Locked Loop Block Diagram

APPLICATIONS INFORMATION

The minimum on-time for the LTC3853 is approximately 90ns, with reasonably good PCB layout, minimum 30% inductor current ripple and at least 10mV to 15mV ripple on the current sense signal. The minimum on-time can be affected by PCB switching noise in the voltage and current loop. However, as the peak sense voltage decreases the minimum on-time gradually increases to 130ns. This is of particular concern in forced continuous applications with low ripple current at light loads. If the duty cycle drops below the minimum on-time limit in this situation, a significant amount of cycle skipping can occur with correspondingly larger current and voltage ripple.

Efficiency Considerations

The percent efficiency of a switching regulator is equal to the output power divided by the input power times 100%. It is often useful to analyze individual losses to determine what is limiting the efficiency and which change would produce the most improvement. Percent efficiency can be expressed as:

$$\% \text{Efficiency} = 100\% - (L1 + L2 + L3 + \dots)$$

where L1, L2, etc. are the individual losses as a percentage of input power.

Although all dissipative elements in the circuit produce losses, four main sources usually account for most of the losses in LTC3853 circuits: 1) IC V_{IN} current, 2) INTV_{CC} regulator current, 3) I²R losses, 4) topside MOSFET transition losses.

1. The V_{IN} current is the DC supply current given in the Electrical Characteristics table, which excludes MOSFET driver and control currents. V_{IN} current typically results in a small (<0.1%) loss.
2. INTV_{CC} current is the sum of the MOSFET driver and control currents. The MOSFET driver current results from switching the gate capacitance of the power MOSFETs. Each time a MOSFET gate is switched from low to high to low again, a packet of charge dQ moves from INTV_{CC} to ground. The resulting dQ/dt is a current out of INTV_{CC} that is typically much larger than the control circuit current. In continuous mode, $I_{\text{GATECHG}} = f(Q_T + Q_B)$, where Q_T and Q_B are the gate charges of the topside and bottom side MOSFETs.

Supplying INTV_{CC} power through EXTV_{CC} from an output-derived source will scale the V_{IN} current required for the driver and control circuits by a factor of (Duty Cycle)/(Efficiency). For example, in a 20V to 5V application, 10mA of INTV_{CC} current results in approximately 2.5mA of V_{IN} current. This reduces the mid-current loss from 10% or more (if the driver was powered directly from V_{IN}) to only a few percent.

3. I²R losses are predicted from the DC resistances of the fuse (if used), MOSFET, inductor, current sense resistor. In continuous mode, the average output current flows through L and R_{SENSE}, but is “chopped” between the topside MOSFET and the synchronous MOSFET. If the two MOSFETs have approximately the same R_{DS(ON)}, then the resistance of one MOSFET can simply be summed with the resistances of L and R_{SENSE} to obtain I²R losses. For example, if each R_{DS(ON)} = 10mΩ, R_L = 10mΩ, R_{SENSE} = 5mΩ, then the total resistance is 25mΩ. This results in losses ranging from 2% to 8% as the output current increases from 3A to 15A for a 5V output, or a 3% to 12% loss for a 3.3V output. Efficiency varies as the inverse square of V_{OUT} for the same external components and output power level. The combined effects of increasingly lower output voltages and higher currents required by high performance digital systems is not doubling but quadrupling the importance of loss terms in the switching regulator system!
4. Transition losses apply only to the topside MOSFET(s), and become significant only when operating at high input voltages (typically 15V or greater). Transition losses can be estimated from:

$$\text{Transition Loss} = (1.7) V_{IN}^2 I_{O(\text{MAX})} C_{RSS} f$$

Other “hidden” losses such as copper trace and internal battery resistances can account for an additional 5% to 10% efficiency degradation in portable systems. It is very important to include these “system” level losses during the design phase. The internal battery and fuse resistance losses can be minimized by making sure that C_{IN} has adequate charge storage and very low ESR at the switching frequency. A 25W supply will typically require a minimum of 20μF to 40μF of capacitance having a maximum of 20mΩ to 50mΩ of ESR. The LTC3853 3-phase architecture reduces this input capacitance requirement up

APPLICATIONS INFORMATION

to 66% over competing solutions. Other losses including Schottky conduction losses during dead time and inductor core losses generally account for less than 2% total additional loss.

Checking Transient Response

The regulator loop response can be checked by looking at the load current transient response. Switching regulators take several cycles to respond to a step in DC (resistive) load current. When a load step occurs, V_{OUT} shifts by an amount equal to ΔI_{LOAD} (ESR), where ESR is the effective series resistance of C_{OUT} . ΔI_{LOAD} also begins to charge or discharge C_{OUT} generating the feedback error signal that forces the regulator to adapt to the current change and return V_{OUT} to its steady-state value. During this recovery time V_{OUT} can be monitored for excessive overshoot or ringing, which would indicate a stability problem. *The availability of the I_{TH} pin not only allows optimization of control-loop behavior but also provides a DC coupled and AC filtered closed-loop response test point. The DC step, rise time and settling at this test point truly reflects the closed-loop response.* Assuming a predominantly second order system, phase margin and/or damping factor can be estimated using the percentage of overshoot seen at this pin. The bandwidth can also be estimated by examining the rise time at the pin. The I_{TH} external components shown in the Typical Application circuit will provide an adequate starting point for most applications.

The I_{TH} series R_C - C_C filter sets the dominant pole-zero loop compensation. The values can be modified slightly (from 0.5 to 2 times their suggested values) to optimize transient response once the final PC layout is done and the particular output capacitor type and value have been determined. The output capacitors need to be selected because the various types and values determine the loop

gain and phase. An output current pulse of 20% to 80% of full-load current having a rise time of $1\mu\text{s}$ to $10\mu\text{s}$ will produce output voltage and I_{TH} pin waveforms that will give a sense of the overall loop stability without breaking the feedback loop. Placing a power MOSFET directly across the output capacitor and driving the gate with an appropriate signal generator is a practical way to produce a realistic load step condition. The initial output voltage step resulting from the step change in output current may not be within the bandwidth of the feedback loop, so this signal cannot be used to determine phase margin. This is why it is better to look at the I_{TH} pin signal which is in the feedback loop and is the filtered and compensated control loop response. The gain of the loop will be increased by increasing R_C and the bandwidth of the loop will be increased by decreasing C_C . If R_C is increased by the same factor that C_C is decreased, the zero frequency will be kept the same, thereby keeping the phase shift the same in the most critical frequency range of the feedback loop. The output voltage settling behavior is related to the stability of the closed-loop system and will demonstrate the actual overall supply performance.

A second, more severe transient is caused by switching in loads with large ($>1\mu\text{F}$) supply bypass capacitors. The discharged bypass capacitors are effectively put in parallel with C_{OUT} , causing a rapid drop in V_{OUT} . No regulator can alter its delivery of current quickly enough to prevent this sudden step change in output voltage if the load switch resistance is low and it is driven quickly. If the ratio of C_{LOAD} to C_{OUT} is greater than 1:50, the switch rise time should be controlled so that the load rise time is limited to approximately $25 \cdot C_{LOAD}$. Thus a $10\mu\text{F}$ capacitor would require a $250\mu\text{s}$ rise time, limiting the charging current to about 200mA.

APPLICATIONS INFORMATION

PC Board Layout Checklist

When laying out the printed circuit board, the following checklist should be used to ensure proper operation of the IC. Figure 12 illustrates the current waveforms present in the various branches of the 3-phase synchronous regulators operating in the continuous mode. Check the following in your layout:

1. Are the top N-channel MOSFETs located within 1 cm of each other with a common drain connection at C_{IN} ? Do not attempt to split the input decoupling for the three channels as it can cause a large resonant loop.
2. Are the signal and power grounds kept separate? The combined IC signal ground pin and the ground return of $C_{INTV_{CC}}$ must return to the combined C_{OUT} (-) terminals. The V_{FB} and I_{TH} traces should be as short as possible. The path formed by the top N-channel MOSFET, Schottky diode and the C_{IN} capacitor should have short leads and PC trace lengths. The output capacitor (-) terminals should be connected as close as possible to the (-) terminals of the input capacitor by placing the capacitors next to each other and away from the Schottky loop described above.
3. Do the LTC3853 V_{FB} pins' resistive dividers connect to the (+) terminals of C_{OUT} ? The resistive divider must be connected between the (+) terminal of C_{OUT} and signal ground. The feedback resistor connections should not be along the high current input feeds from the input capacitor(s).
4. Are the $SENSE^+$ and $SENSE^-$ leads routed together with minimum PC trace spacing? The filter capacitor between $SENSE^+$ and $SENSE^-$ should be as close as possible to the IC. Ensure accurate current sensing with Kelvin connections at the sense resistor or inductor, whichever is used for current sensing.
5. Is the $INTV_{CC}$ decoupling capacitor connected close to the IC, between the $INTV_{CC}$ and the power ground pins? This capacitor carries the MOSFET drivers current peaks. An additional 1 μ F ceramic capacitor placed immediately next to the $INTV_{CC}$ and PGND pins can help improve noise performance substantially.
6. Keep the switching nodes (SW), top gate nodes (TG), and boost nodes (BOOST) away from sensitive small-signal nodes, especially from another channel's voltage and current sensing feedback pins. All of these nodes have very large and fast moving signals and therefore should be kept on the "output side" of the LTC3853 and occupy minimum PC trace area. If DCR sensing is used, place the top resistor (Figure 2b, R1) close to the switching node.
7. Use a modified "star ground" technique: a low impedance, large copper area central grounding point on the same side of the PC board as the input and output capacitors with tie-ins for the bottom of the $INTV_{CC}$ decoupling capacitor, the bottom of the voltage feedback resistive divider and the SGND pin of the IC.

APPLICATIONS INFORMATION

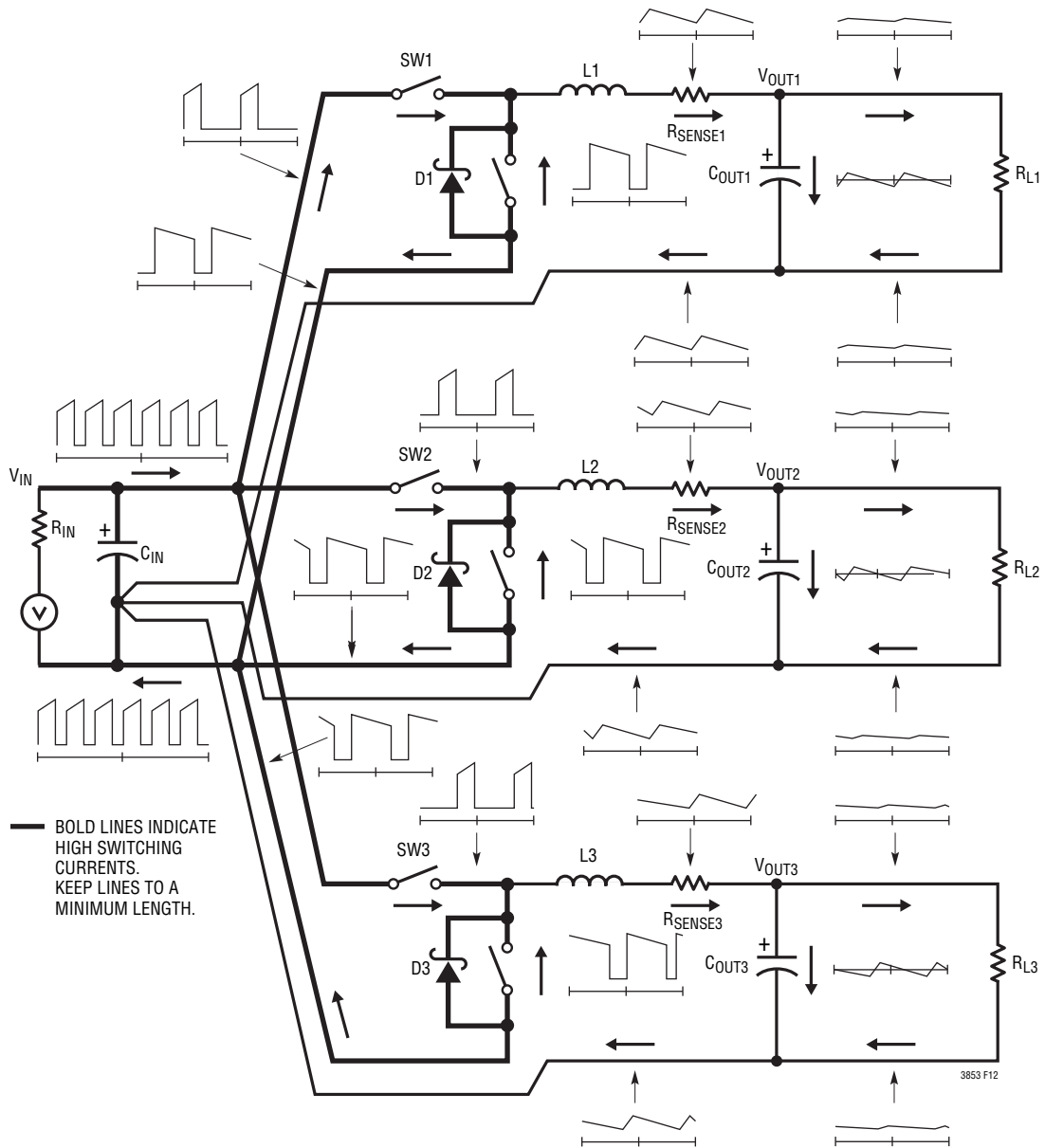

Figure 12. Branch Current Waveforms

APPLICATIONS INFORMATION

PC Board Layout Debugging

Start with one controller at a time. It is helpful to use a DC-50MHz current probe to monitor the current in the inductor while testing the circuit. Monitor the output switching node (SW pin) to synchronize the oscilloscope to the internal oscillator and probe the actual output voltage as well. Check for proper performance over the operating voltage and current range expected in the application. The frequency of operation should be maintained over the input voltage range down to dropout and until the output load drops below the low current operation threshold—typically 10% of the maximum designed current level in Burst Mode operation.

The duty cycle percentage should be maintained from cycle to cycle in a well-designed, low noise PCB implementation. Variation in the duty cycle at a subharmonic rate can suggest noise pickup at the current or voltage sensing inputs or inadequate loop compensation. Overcompensation of the loop can be used to tame a poor PC layout if regulator bandwidth optimization is not required. Only after each controller is checked for its individual performance should all controllers be turned on at the same time. A particularly difficult region of operation is when one controller channel is nearing its current comparator trip point when another channel is turning on its top MOSFET. This occurs around 33% and 66% duty cycle on a channel in triple mode, due to the phasing of the internal clocks and may cause minor duty cycle jitter.

Reduce V_{IN} from its nominal level to verify operation of the regulator in dropout. Check the operation of the undervoltage lockout circuit by further lowering V_{IN} while monitoring the outputs to verify operation.

Investigate whether any problems exist only at higher output currents or only at higher input voltages. If problems coincide with high input voltages and low output currents, look for capacitive coupling between the BOOST, SW, TG, and possibly BG connections and the sensitive voltage and current pins. The capacitor placed across the current sensing pins needs to be placed immediately adjacent to the pins of the IC. This capacitor helps to minimize the effects of differential noise injection due to high frequency capacitive coupling. If problems are encountered with high current output loading at lower input voltages, look

for inductive coupling between C_{IN} , Schottky and the top MOSFET components to the sensitive current and voltage sensing traces. In addition, investigate common ground path voltage pickup between these components and the SGND pin of the IC.

Design Example

As a design example for a three channel medium current regulator, assume $V_{IN} = 12V$ (nominal), $V_{IN} = 20V$ (maximum), $V_{OUT1} = 5V$, $V_{OUT2} = 3.3V$, $V_{OUT3} = 1.2V$, $I_{MAX1,2,3} = 5A$, and $f = 500kHz$ (see Figure 13).

The regulated output voltages are determined by:

$$V_{OUT} = 0.8V \cdot \left(1 + \frac{R_B}{R_A} \right)$$

Using 20k 1% resistors from both V_{FB} nodes to ground, the top feedback resistors are (to the nearest 1% standard value) 105k, 63.4k and 10k.

The minimum on-time occurs on channel 3 at the maximum V_{IN} , and should not be less than 90ns:

$$t_{ON(MIN)} = \frac{V_{OUT}}{V_{IN(MAX)} \cdot f} = \frac{1.2V}{20V(500kHz)} = 120ns$$

The frequency is set by biasing the FREQ/PLLFLTR pin to 1.2V (see Figure 10), using a divider from $INTV_{CC}$. This voltage will decrease as V_{IN} approaches 5V, lowering the switching frequency. If a separate 5V supply is connected to $EXTV_{CC}$, $INTV_{CC}$ will remain at 5V even if V_{IN} decreases.

The inductance values are based on a 35% ripple current assumption (1.75A for each channel) at nominal input voltage:

$$L = \frac{V_{OUT}}{f \cdot \Delta I_{L(NOM)}} \left(1 - \frac{V_{OUT}}{V_{IN(NOM)}} \right)$$

Channel 1 will require 3.3 μ H, channel 2 will require 2.8 μ H and channel 3 will require 1.25 μ H. The next highest standard values are 3.3 μ H, 3.3 μ H and 1.5 μ H. At the maximum input voltage (20V), the ripple will be:

$$\Delta I_{L(MAX)} = \frac{V_{OUT}}{f \cdot L} \left(1 - \frac{V_{OUT}}{V_{IN(MAX)}} \right)$$

APPLICATIONS INFORMATION

For channel 1, the DCR_{SENSE} filter/divider values are:

$$R1 = \frac{R1 \parallel R2}{R_D} = \frac{1100\Omega}{0.23} \cong 4.75k;$$

$$R2 = \frac{R1 \cdot R_D}{1 - R_D} = \frac{4.75k \cdot 0.23}{1 - 0.23} \cong 1430\Omega$$

The power loss in R1 at the maximum input voltage is:

$$P_{LOSSR1} = \frac{(V_{IN(MAX)} - V_{OUT}) \cdot V_{OUT}}{R1}$$

$$= \frac{(20V - 5V) \cdot 5V}{4.75k} = 15.8mW$$

The respective values for Channel 2 are $R1 = 4.75k$, $R2 = 1430\Omega$; and $P_{LOSSR1} = 11.6mW$. And for Channel 3 are $R1 = 2.21k$, $R2 = 1.82k$; and $P_{LOSSR1} = 10.2mW$.

Burst Mode operation is chosen for high light load efficiency (Figure 14) by floating the MODE/PLLIN pin. Power loss due to the DCR sensing network is slightly higher at light loads than would have been the case with a suitable sense resistor ($9m\Omega$). At heavier loads, DCR sensing provides higher efficiency.

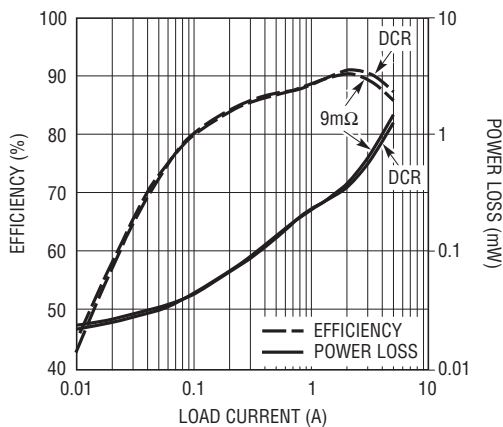

Figure 14. Design Example Efficiency vs Load

The power dissipation on the topside MOSFET can be easily estimated. Choosing a Siliconix Si4816BDY dual MOSFET results in: $R_{DS(ON)} = 0.023\Omega/0.016\Omega$, $C_{MILLER} \cong 100pF$. At maximum input voltage with $T(\text{estimated}) = 50^\circ C$:

$$P_{MAIN} = \frac{5V}{20V} (5)^2 [1 + (0.005)(50^\circ C - 25^\circ C)] \cdot$$

$$(0.023\Omega) + (20V)^2 \left(\frac{5A}{2} \right) (2\Omega) (100pF) \cdot$$

$$\left[\frac{1}{5 - 2.3} + \frac{1}{2.3} \right] (500kHz) = 243mW$$

A short-circuit to ground will result in a folded back current of:

$$I_{SC} = \frac{(1/3)75mV}{0.009\Omega} - \frac{1}{2} \left(\frac{90ns(20V)}{3.3\mu H} \right) = 2.5A$$

with a typical value of $R_{DS(ON)}$ and $\delta = (0.005/^\circ C)(25) = 0.125$. The resulting power dissipated in the bottom MOSFET is:

$$P_{SYNC} = \frac{20V - 5V}{20V} (2.5A)^2 (1.125)(0.016\Omega)$$

$$= 84mW$$

which is less than under full-load conditions.

C_{IN} is chosen for an RMS current rating of at least 2A at temperature assuming only one channel is on. C_{OUT} is chosen with an ESR of 0.02Ω for low output ripple. The output ripple in continuous mode will be highest at the maximum input voltage. The output voltage ripple due to ESR is approximately:

$$V_{ORIPPLE} = R_{ESR} (\Delta I_L) = 0.02\Omega (1.5A) = 30mV_{P-P}$$

APPLICATIONS INFORMATION

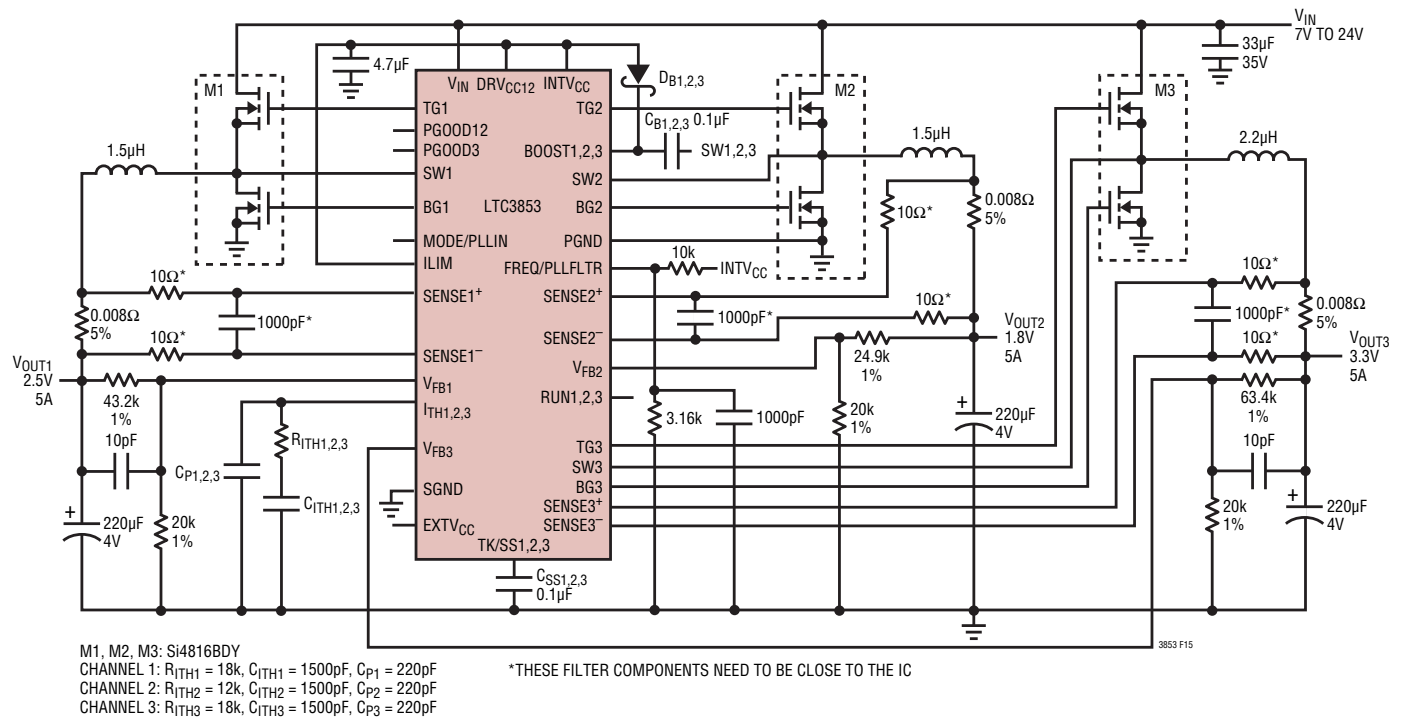
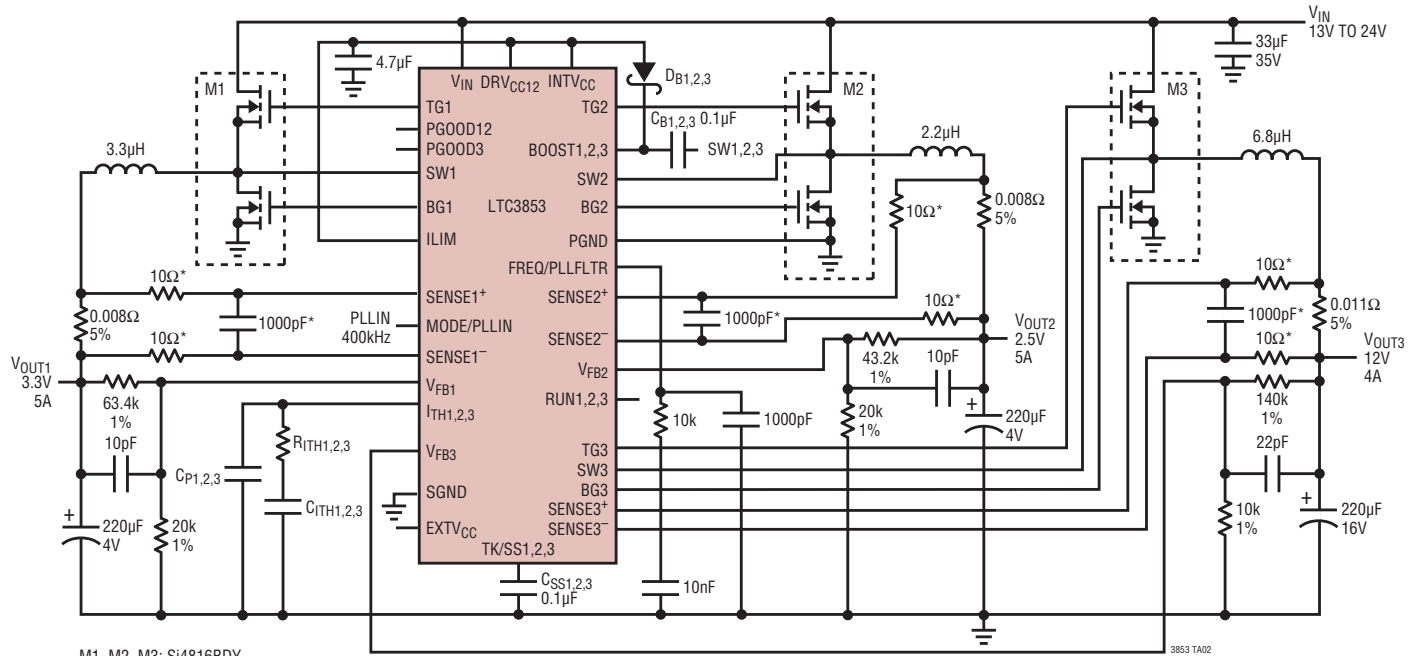

Figure 15. Triple 2.5V/1.8V/3.3V 5A Step-Down Converter with R_{SENSE} , $f_{SW} = 500kHz$

TYPICAL APPLICATIONS

Triple 3.3V/2.5V/12V, 5A Step-Down Converter with R_{SENSE} Synchronized at 400kHz



M1, M2, M3: SI4816BDY
 CHANNEL 1: $R_{ITH1} = 18k$, $C_{ITH1} = 1500pF$, $C_{P1} = 220pF$
 CHANNEL 2: $R_{ITH2} = 18k$, $C_{ITH2} = 1500pF$, $C_{P2} = 220pF$
 CHANNEL 3: $R_{ITH3} = 43k$, $C_{ITH3} = 470pF$, $C_{P3} = 330pF$

*THESE FILTER COMPONENTS NEED TO BE CLOSE TO THE IC

Triple 1.8V/1.2V/2.5V, 15A High Current Step-Down Converter with R_{SENSE} , $f_{SW} = 400kHz$

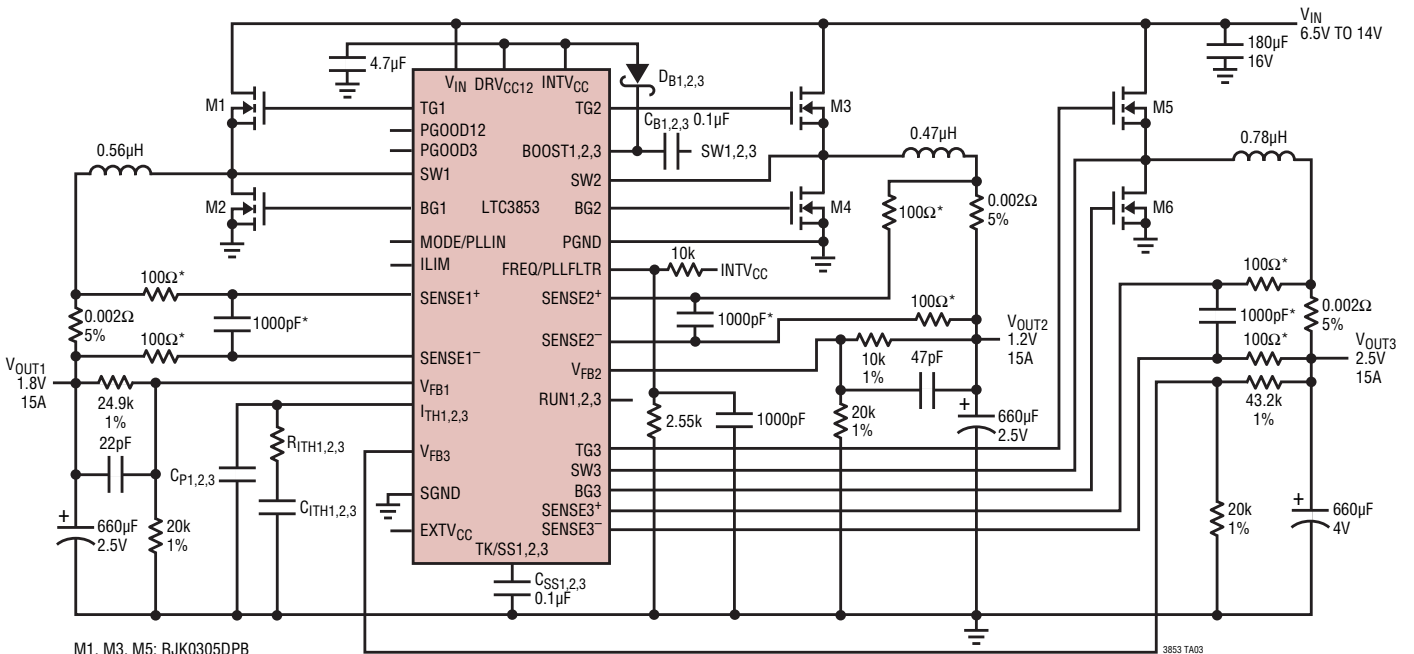

M1, M3, M5: RJK0305DPB
 M2, M4, M6: RJK0301DPB
 CHANNEL 1: $R_{ITH1} = 15k$, $C_{ITH1} = 1500pF$, $C_{P1} = 330pF$
 CHANNEL 2: $R_{ITH2} = 10k$, $C_{ITH2} = 1500pF$, $C_{P2} = 220pF$
 CHANNEL 3: $R_{ITH3} = 13k$, $C_{ITH3} = 1500pF$, $C_{P3} = 330pF$

*THESE FILTER COMPONENTS NEED TO BE CLOSE TO THE IC

TYPICAL APPLICATIONS

Dual 1.2V/2.5V High Current Step-Down Converter with R_{SENSE}

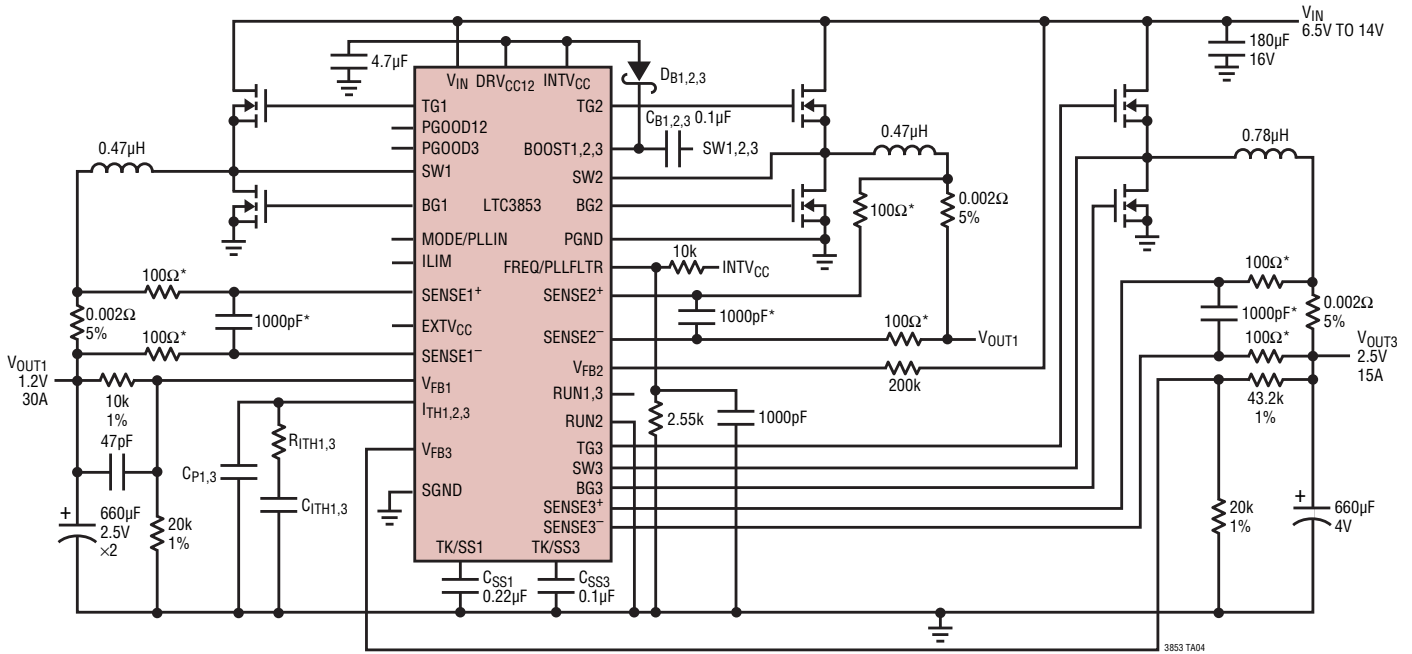

CHANNEL 1: R_{ITH1} = 10k, C_{ITH1} = 1500pF, C_{p1} = 220pF
 CHANNEL 2: I_{TH1} AND I_{TH2} SHORTED TOGETHER,
 TK/SS1 AND TK/SS2 SHORTED TOGETHER
 CHANNEL 3: R_{ITH3} = 13k, C_{ITH3} = 1500pF, C_{p3} = 330pF

*THESE FILTER COMPONENTS NEED TO BE CLOSE TO THE IC

3853 TA04

PACKAGE DESCRIPTION

Please refer to <http://www.linear.com/designtools/packaging/> for the most recent package drawings.

UJ Package
40-Lead Plastic QFN (6mm × 6mm)
 (Reference LTC DWG # 05-08-1728 Rev 0)

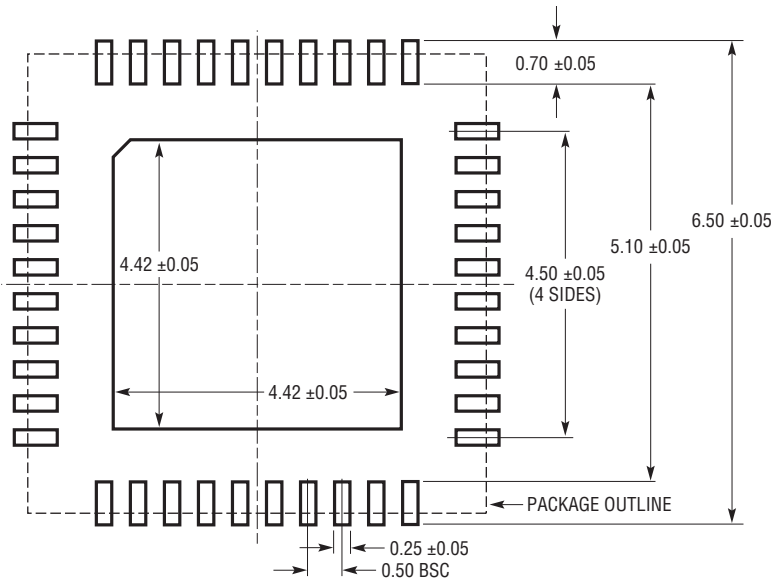

RECOMMENDED SOLDER PAD PITCH AND DIMENSIONS
 APPLY SOLDER MASK TO AREAS THAT ARE NOT SOLDERED

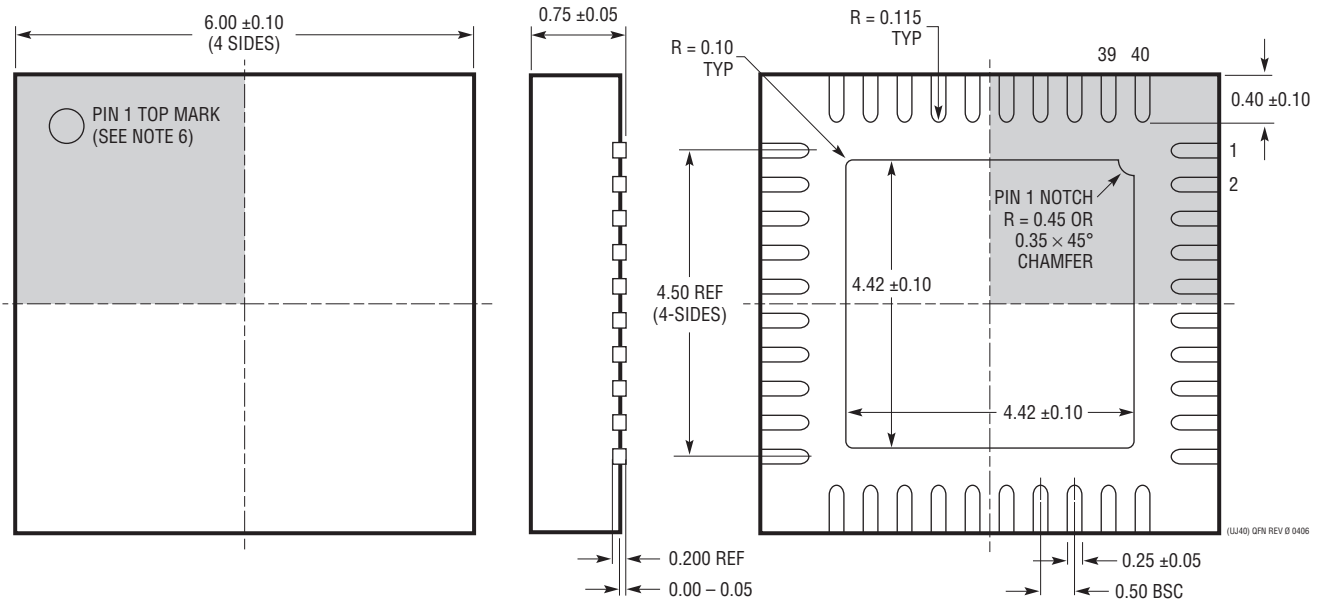

- NOTE:
1. DRAWING IS A JEDEC PACKAGE OUTLINE VARIATION OF (WJJD-2)
 2. DRAWING NOT TO SCALE
 3. ALL DIMENSIONS ARE IN MILLIMETERS
 4. DIMENSIONS OF EXPOSED PAD ON BOTTOM OF PACKAGE DO NOT INCLUDE MOLD FLASH. MOLD FLASH, IF PRESENT, SHALL NOT EXCEED 0.20mm ON ANY SIDE, IF PRESENT
 5. EXPOSED PAD SHALL BE SOLDER PLATED
 6. SHADED AREA IS ONLY A REFERENCE FOR PIN 1 LOCATION ON THE TOP AND BOTTOM OF PACKAGE

BOTTOM VIEW—EXPOSED PAD

REVISION HISTORY

REV	DATE	DESCRIPTION	PAGE NUMBER
A	12/10	Change to Operating Temperature Range	2
		Updated Order Information Part Marking	2
		Edits made to Note 2 and 3	4
		Changes to graphs G01 and G02	5
		Updated Related Parts table	36
B	8/14	Added H- and MP-grade parts	2, 3, 4, 7
C	3/15	Corrected IC pin names	2
		Added V_{OUT} range	3
		Corrected typographical errors	5, 21, 22 and 30

TYPICAL APPLICATION

Three Phase 2.5V Output High Current Step-Down Converter with R_{SENSE}

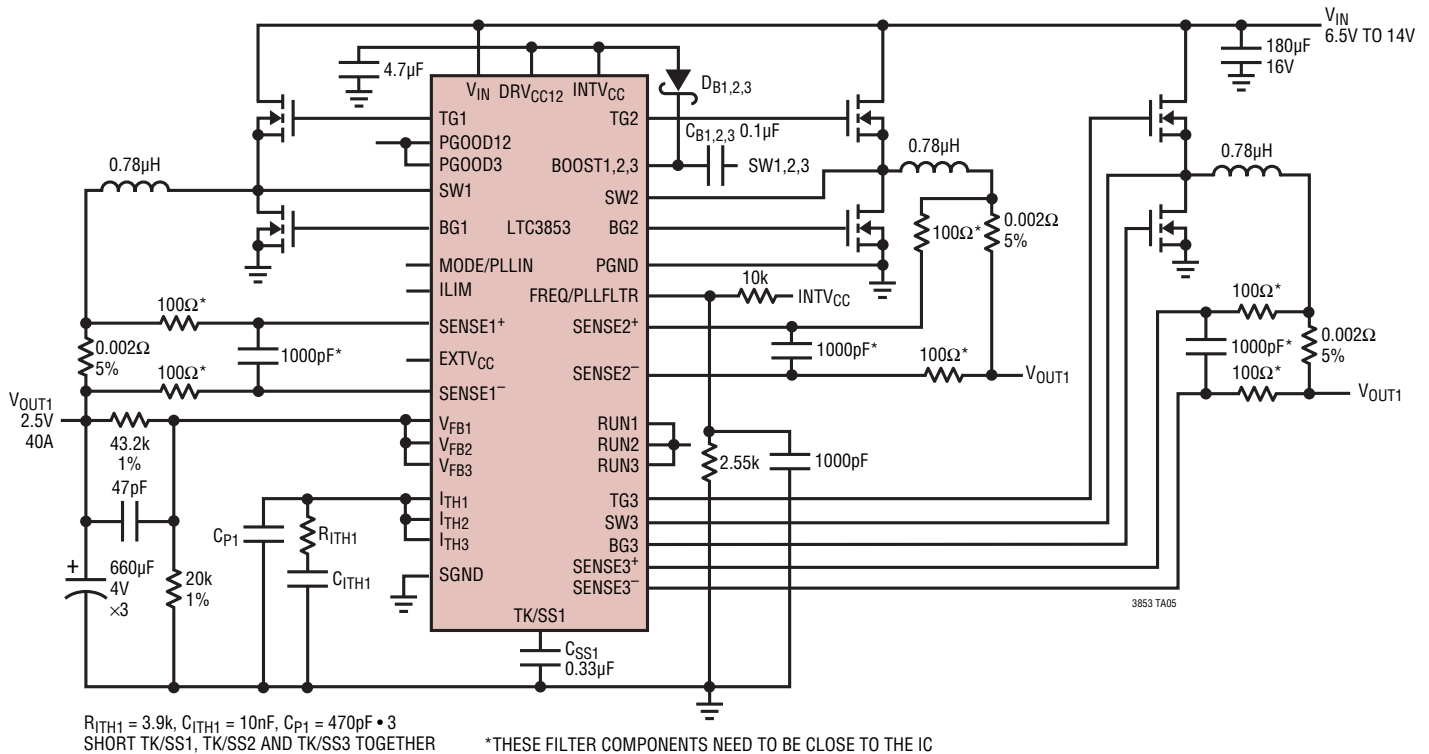

RELATED PARTS

PART NUMBER	DESCRIPTION	COMMENTS
LTC3850/LTC3850-1/ LTC3850-2	Dual Output Synchronous Step-Down DC/DC Controller R _{SENSE} or DCR Current Sensing	Phase-Lockable Fixed 250kHz to 780kHz Frequency, 4V ≤ V _{IN} ≤ 30V, 0.8V ≤ V _{OUT} ≤ 5.25V
LTC3861	Dual Output Synchronous Step-Down DC/DC Controller with Diff Amp, DCR Current Sense, PolyPhase® and Three-State Output Drive	Operates with Power Blocks, DRMos Devices or External MOSFETs 3V ≤ V _{IN} ≤ 24V
LTC3855	Dual Output Synchronous Step-Down DC/DC Controller with Diff Amp, PolyPhase and DCR Temperature Compensation	Phase-Lockable Fixed Frequency 250kHz to 770kHz, 4.5V ≤ V _{IN} ≤ 38V, 0.8V ≤ V _{OUT} ≤ 12V
LTC3829	3-Phase, Single Output Synchronous Step-Down DC/DC Controller with Diff Amp, PolyPhase and DCR Temperature Compensation	Phase-Lockable Fixed 250kHz to 770kHz Frequency, 4.5V ≤ V _{IN} ≤ 38V, 0.8V ≤ V _{OUT} ≤ 5V
LTC3856	2-Phase, Single Output Synchronous Step-Down DC/DC Controller with Diff Amp, PolyPhase and DCR Temperature Compensation	Phase-Lockable Fixed Frequency 250kHz to 770kHz, 4.5V ≤ V _{IN} ≤ 38V, 0.8V ≤ V _{OUT} ≤ 5V
LTC3851A/ LTC3851A-1	Single Output Synchronous Step-Down DC/DC Controller R _{SENSE} or DCR Current Sensing	Phase-Lockable Fixed Operating Frequency 250kHz to 750kHz, 4V ≤ V _{IN} ≤ 38V, 0.8V ≤ V _{OUT} ≤ 5.25V, MSOP-16E 3mm × 3mm QFN-16, SSOP-16

Looking for pricing, stock, or lifecycle information?

Click below to explore more details on WIN SOURCE:

 [View LTC3853EUJ#PBF on WIN SOURCE](#)

 [Linear Technology](#) Information

Optimize Your Supply Chain with WIN SOURCE Solutions

-  Global Sourcing Solution
-  Obsolete Management
-  Cost Control Management
-  Shortage Management
-  Alternative Solution
-  Excess Inventory Management