



THE DATASHEET OF CNX48U3SD



DESCRIPTION

The CNX48U, H11BX, MOC8080 and TIL113 have a gallium arsenide infrared emitter optically coupled to a silicon planar photodarlington.

CNX48U	H11B1	H11B2	H11B255	H11B3
MOC8080	TIL113			

FEATURES

- High sensitivity to low input drive current
- Meets or exceeds all JEDEC Registered Specifications
- VDE 0884 approval available as a test option
-add option .300. (e.g., H11B1.300)

APPLICATIONS

- Low power logic circuits
- Telecommunications equipment
- Portable electronics
- Solid state relays
- Interfacing coupling systems of different potentials and impedances.

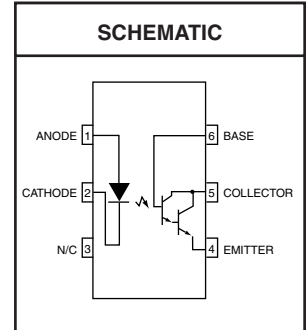
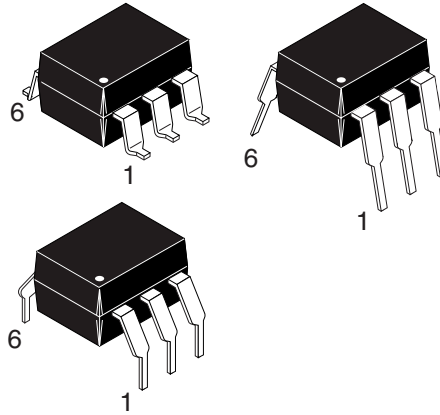

Parameter	Symbol	Device	Value	Units
TOTAL DEVICE				
Storage Temperature	T_{STG}	All	-55 to +150	°C
Operating Temperature	T_{OPR}	All	-55 to +100	°C
Lead Solder Temperature	T_{SOL}	All	260 for 10 sec	°C
Total Device Power Dissipation @ $T_A = 25^\circ\text{C}$ Derate above 25°C	P_D	All	250	mW
			3.3	mW/°C
EMITTER				
Continuous Forward Current	I_F	All	100	mA
Reverse Voltage	V_R	All	6	V
Forward Current - Peak (300 μs , 2% Duty Cycle)	$I_{F(pk)}$	All	3.0	A
LED Power Dissipation @ $T_A = 25^\circ\text{C}$ Derate above 25°C	P_D	All	100	mW
			1.8	mW/°C
DETECTOR				
Collector-Emitter Breakdown Voltage	BV_{CEO}	CNX48U, TIL113	30	V
		H11B1, H11B2 H11B3	25	
		H11B255 MOC8080	55	
Collector-Base Breakdown Voltage	BV_{CBO}	CNX48U, H11B1 H11B2, H11B3 TIL113	30	V
		H11B255 MOC8080	55	V
Emitter-Collector Breakdown Voltage	BV_{ECO}	All	7	V
Detector Power Dissipation @ $T_A = 25^\circ\text{C}$ Derate above 25°C	P_D	All	150	mW
			2.0	mW/°C

CNX48U	H11B1	H11B2	H11B255	H11B3
MOC8080	TIL113			

ELECTRICAL CHARACTERISTICS ($T_A = 25^\circ\text{C}$ Unless otherwise specified.)

INDIVIDUAL COMPONENT CHARACTERISTICS

Parameter	Test Conditions	Symbol	Device	Min	Typ**	Max	Unit
EMITTER Input Forward Voltage	($I_F = 10\text{ mA}$)	V_F	H11B1, H11B2 H11B255 MOC8080 TIL113	0.8	1.2	1.5	V
	($I_F = 10\text{ mA}$)		CNX48U		1.2	1.3	
	($I_F = 10\text{ mA}$, $T_A = -55^\circ\text{C}$)		MOC8080	0.9	1.3	1.7	
	($I_F = 10\text{ mA}$, $T_A = 100^\circ\text{C}$)			0.7	1.05	1.4	
	($I_F = 50\text{ mA}$)		H11B3		1.35	1.5	
Reverse Leakage Current	($V_R = 6\text{ V}$)	I_R	All		0.001	10	μA
Capacitance	($V_F = 0\text{ V}$, $f = 1.0\text{ MHz}$)	C	All		50		pF
DETECTOR Collector-Emitter Breakdown Voltage	($I_C = 1\text{ mA}$, $I_F = 0$)	BV_{CEO}	CNX48U	30	60		V
	($I_C = 100\text{ }\mu\text{A}$, $I_F = 0$)		TIL113				
	($I_C = 10\text{ mA}$, $I_F = 0$)		H11B1, H11B2 H11B3	25	60		
	($I_C = 100\text{ }\mu\text{A}$, $I_F = 0$)		H11B255	55	70		
	($I_C = 1\text{ mA}$, $I_F = 0$)		MOC8080				
Collector-Base Breakdown Voltage	($I_C = 100\text{ }\mu\text{A}$, $I_E = 0$)	BV_{CBO}	CNX48U, H11B1 H11B2, H11B3 TIL113	30	100		V
	($I_C = 100\text{ }\mu\text{A}$, $I_F = 0$)		H11B255 MOC8080	55	100		
Emitter-Collector Breakdown Voltage	($I_E = 100\text{ }\mu\text{A}$, $I_B = 0$)	BV_{ECO}	All	7	10		V
Collector-Emitter Dark Current	($V_{CE} = 10\text{ V}$, Base Open)	I_{CEO}	All		1	100	nA

Note

 ** Typical values at $T_A = 25^\circ\text{C}$

CNX48U	H11B1	H11B2	H11B255	H11B3
MOC8080	TIL113			

TRANSFER CHARACTERISTICS ($T_A = 25^\circ\text{C}$ Unless otherwise specified.)								
DC Characteristics	Test Conditions	Symbol	Device	Min	Typ**	Max	Units	
Collector Output Current ⁽¹⁾	$(I_F = 10\text{ mA}, V_{CE} = 5\text{ V})$	I_C (CTR)	MOC8080	50 (500)			mA (%)	
			H11B255	10 (100)				
	$(I_F = 10\text{ mA}, V_{CE} = 1\text{ V})$		CNX48U	60 (600)				
			TIL113	30 (300)				
	$(I_F = 1\text{ mA}, V_{CE} = 5\text{ V})$		H11B1	5 (500)				
			H11B2	2 (200)				
	$(I_F = 1\text{ mA}, V_{CE} = 1\text{ V})$		CNX48U	5 (500)				
$(I_F = 0.5\text{ mA}, V_{CE} = 1\text{ V})$	1.75 (350)							
Saturation Voltage	$(I_F = 1\text{ mA}, I_C = 1\text{ mA})$	$V_{CE(sat)}$	H11B1, H11B2 H11B3, MOC8080			1.0	V	
	$(I_F = 5\text{ mA}, I_C = 10\text{ mA})$		CNX48U			1.0		
	$(I_F = 50\text{ mA}, I_C = 50\text{ mA})$		H11B255			1.0		
	$(I_F = 8\text{ mA}, I_C = 2\text{ mA})$		TIL113			1.25		
AC Characteristics	$(I_C = 10\text{ mA}, V_{CE} = 10\text{ V})$ $(R_L = 100\ \Omega)$ (Fig.7)	t_{on}	H11B1 H11B2		25		μs	
		t_{off}	H11B255 H11B3		18			
	$(I_F = 10\text{ mA}, V_{CC} = 5\text{ V})$ $(R_E = 100\ \Omega), (R_{BE} = 1\text{M}\Omega)$ (Fig. 8)	t_{on}	CNX48U			3.5		
		t_{off}				36		
	$(I_F = 1\text{ mA}, V_{CC} = 5\text{ V})$ $(R_E = 1\text{k}\Omega), (R_{BE} = 10\text{M}\Omega)$ (Fig. 8)	t_{on}	CNX48U			70		
		t_{off}				190		
	$(I_F = 5\text{ mA}, V_{CC} = 10\text{ V})$ $(R_L = 100\ \Omega)$ (Fig.7)	t_{on}	MOC8080			3.5		
		t_{off}				25		
	$(I_F = 200\text{ mA}, I_C = 50\text{ mA})$ $(V_{CC} = 10\text{ V}) (R_L = 100\ \Omega)$ (Fig.7)	t_{on}	TIL113			0.35		5
		t_{off}				55		100

ISOLATION CHARACTERISTICS							
Characteristic	Test Conditions	Symbol	Min	Typ**	Max	Units	
Input-Output Isolation Voltage ⁽²⁾	$(I_{I-O} \leq 1\ \mu\text{A}, V_{rms}, t = 1\text{ min.})$		5300			Vac(rms)	
Isolation Resistance ⁽²⁾	$(V_{I-O} = 500\text{ VDC})$	R_{ISO}		10^{11}		Ω	
Isolation Capacitance ⁽²⁾	$(V_{I-O} = \emptyset, f = 1\text{ MHz})$	C_{ISO}		0.8		pf	

Note
 ** Typical values at $T_A = 25^\circ\text{C}$

**CNX48U H11B1 H11B2 H11B255 H11B3
MOC8080 TIL113**

Fig. 1 Output Current vs. Input Current

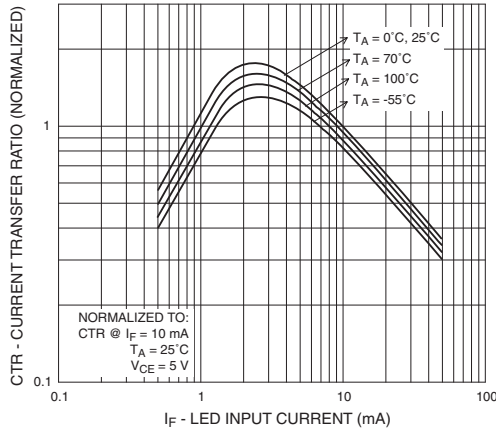

Fig. 2 Current Transfer Ratio vs. Ambient Temperature

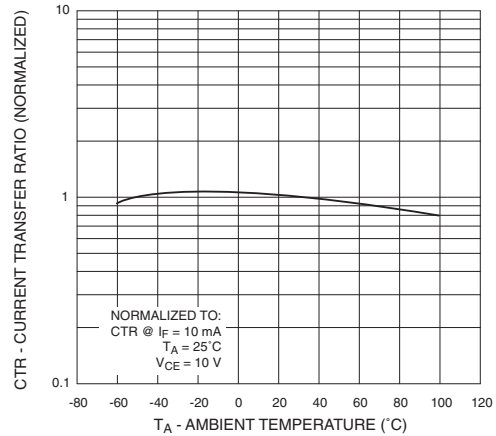

Fig. 3 Collector Current vs. Collector-Emitter Voltage

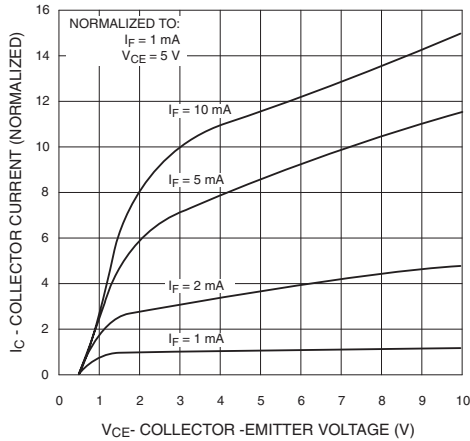

Fig. 4 Dark Current vs. Ambient Temperature

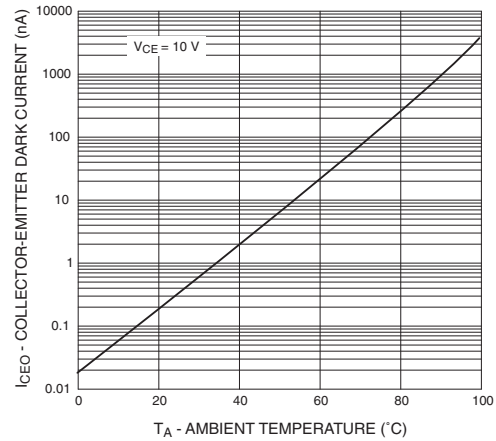

Fig. 5 Turn-On Time vs. Input Current

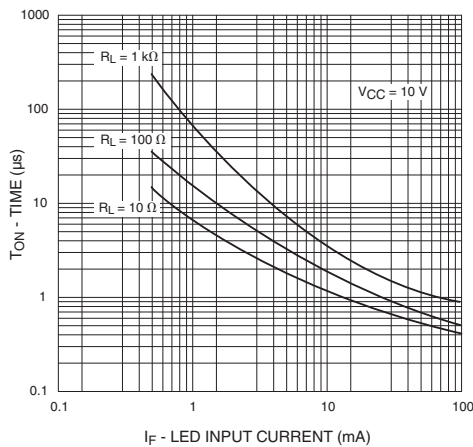
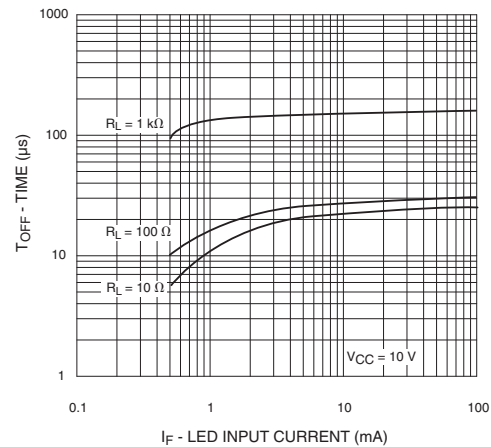

Fig. 6 Turn-Off Time vs. Input Current



CNX48U H11B1 H11B2 H11B255 H11B3
MOC8080 TIL113

TYPICAL ELECTRO-OPTICAL CHARACTERISTIC CURVES

(25°C Free air temperature unless otherwise specified) (Cont.)

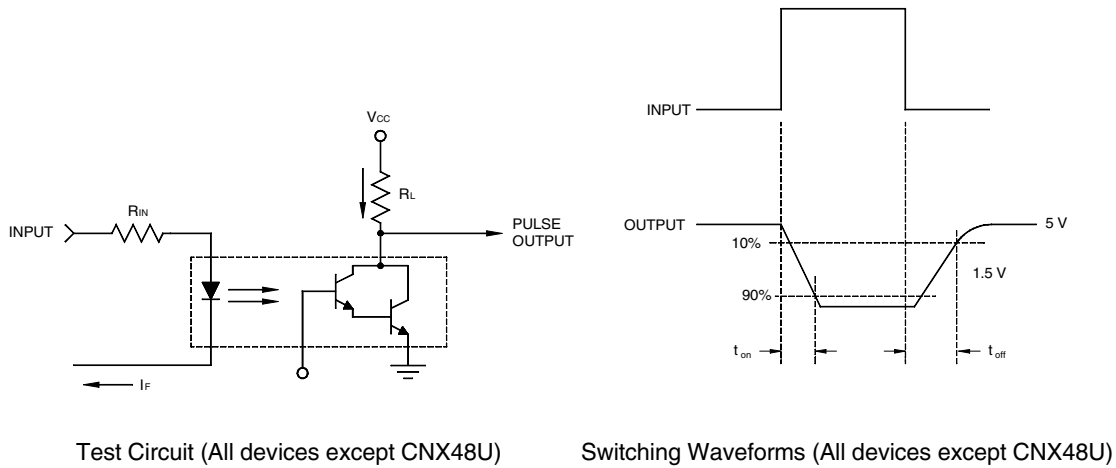

Fig. 7 Switching Time Test Circuit and Waveforms (All devices except CNX48U)

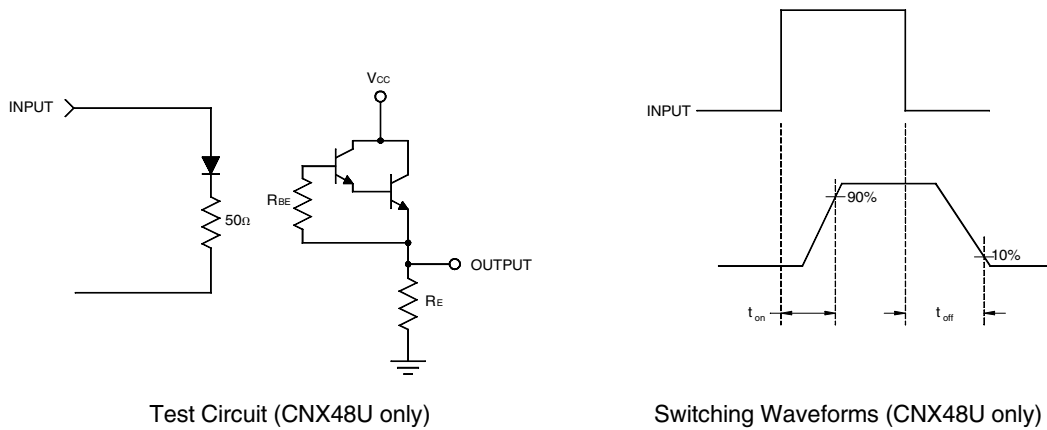

Fig. 8 Switching Time Test Circuit and Waveforms (CNX48U only)

Notes

1. The current transfer ratio (I_C/I_F) is the ratio of the detector collector current to the LED input current with $V_{CE} @ 10\text{ V}$.
2. For this test, LED pins 1 and 2 are common and phototransistor pins 4,5 and 6 are common.

CNX48U	H11B1	H11B2	H11B255	H11B3
MOC8080	TIL113			

ORDERING INFORMATION

Option	Order Entry Identifier	Description
S	.S	Surface Mount Lead Bend
SD	.SD	Surface Mount; Tape and reel
W	.W	0.4" Lead Spacing
300	.300	VDE 0884
300W	.300W	VDE 0884, 0.4" Lead Spacing
3S	.3S	VDE 0884, Surface Mount
3SD	.3SD	VDE 0884, Surface Mount, Tape & Reel

QT Carrier Tape Specifications ("D" Taping Orientation)

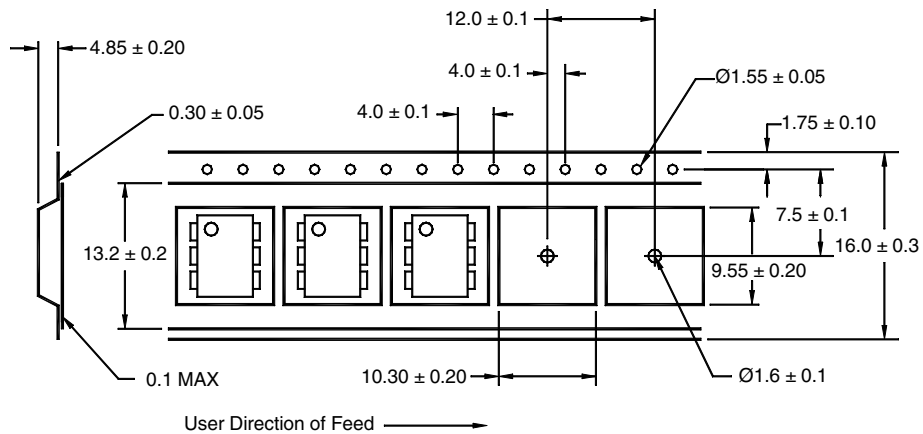

NOTE

All dimensions are millimeters

DISCLAIMER

FAIRCHILD SEMICONDUCTOR RESERVES THE RIGHT TO MAKE CHANGES WITHOUT FURTHER NOTICE TO ANY PRODUCTS HEREIN TO IMPROVE RELIABILITY, FUNCTION OR DESIGN. FAIRCHILD DOES NOT ASSUME ANY LIABILITY ARISING OUT OF THE APPLICATION OR USE OF ANY PRODUCT OR CIRCUIT DESCRIBED HEREIN; NEITHER DOES IT CONVEY ANY LICENSE UNDER ITS PATENT RIGHTS, NOR THE RIGHTS OF OTHERS.

LIFE SUPPORT POLICY

FAIRCHILD'S PRODUCTS ARE NOT AUTHORIZED FOR USE AS CRITICAL COMPONENTS IN LIFE SUPPORT DEVICES OR SYSTEMS WITHOUT THE EXPRESS WRITTEN APPROVAL OF THE PRESIDENT OF FAIRCHILD SEMICONDUCTOR CORPORATION. As used herein:

1. Life support devices or systems are devices or systems which, (a) are intended for surgical implant into the body, or (b) support or sustain life, and (c) whose failure to perform when properly used in accordance with instructions for use provided in the labeling, can be reasonably expected to result in a significant injury of the user.
2. A critical component in any component of a life support device or system whose failure to perform can be reasonably expected to cause the failure of the life support device or system, or to affect its safety or effectiveness.

Looking for pricing, stock, or lifecycle information?

Click below to explore more details on WIN SOURCE:

- ⊖ [View CNX48U3SD on WIN SOURCE](#)
- ⊖ [Fairchild/ON Semiconductor Information](#)

Optimize Your Supply Chain with WIN SOURCE Solutions

- ✓ Global Sourcing Solution
- ✓ Obsolete Management
- ✓ Cost Control Management
- ✓ Shortage Management
- ✓ Alternative Solution
- ✓ Excess Inventory Management