



**THE DATASHEET OF
UC28023DWRG4**



Table of Contents

1 Features	1	8.3 Feature Description.....	11
2 Applications	1	8.4 Device Functional Modes.....	14
3 Description	1	9 Application and Implementation	15
4 Revision History	2	9.1 Application Information.....	15
5 Pin Configuration and Functions	3	9.2 Typical Application	15
6 Specifications	4	10 Power Supply Recommendations	17
6.1 Absolute Maximum Ratings	4	11 Layout	18
6.2 ESD Ratings.....	4	11.1 Layout Guidelines	18
6.3 Recommended Operating Conditions.....	4	11.2 Layout Example	18
6.4 Thermal Information	4	12 Device and Documentation Support	19
6.5 Electrical Characteristics.....	5	12.1 Documentation Support	19
6.6 Switching Characteristics	6	12.2 Related Links	19
6.7 Typical Characteristics	7	12.3 Receiving Notification of Documentation Updates	19
7 Parameter Measurement Information	8	12.4 Community Resources.....	19
7.1 Control Methods and Test Circuits.....	8	12.5 Trademarks	19
8 Detailed Description	10	12.6 Electrostatic Discharge Caution.....	19
8.1 Overview	10	12.7 Glossary	19
8.2 Functional Block Diagram	10	13 Mechanical, Packaging, and Orderable Information	19

4 Revision History

NOTE: Page numbers for previous revisions may differ from page numbers in the current version.

Changes from Revision F (August 2010) to Revision G

Page

• Added <i>Device Information</i> table, <i>Pin Configuration and Functions</i> section, <i>Specifications</i> section, <i>ESD Ratings</i> table, <i>Recommended Operating Conditions</i> table, <i>Switching Characteristics</i> table, <i>Typical Characteristics</i> section, <i>Detailed Description</i> section, <i>Application and Implementation</i> section, <i>Power Supply Recommendations</i> section, <i>Layout</i> section, <i>Device and Documentation Support</i> section, and <i>Mechanical, Packaging, and Orderable Information</i> section	1
• Deleted <i>Ordering Information</i> table; see POA at the end of the data sheet.....	1
• Moved Delay to output time parameters from <i>Electrical Characteristics</i> to <i>Switching Characteristics</i>	1
• Moved rise and fall time parameters from <i>Electrical Characteristics</i> to <i>Switching Characteristics</i>	1
• Deleted Lead temperature soldering rating in the <i>Absolute Maximum Ratings</i> table	4
• Added <i>Thermal Information</i> table	4
• Changed $R_{\theta JA}$ values for DW (SOIC) package From: 50°C/W to 100°C/W To: 70.5°C/W and for N (PDIP) package From: 90°C/W To: 44.5°C/W	4
• Changed $R_{\theta JC(top)}$ values for DW (SOIC) package From: 27°C/W To: 31.8°C/W and for N (PDIP) package From: 45°C/W To: 34.3°C/W.....	4

5 Pin Configuration and Functions

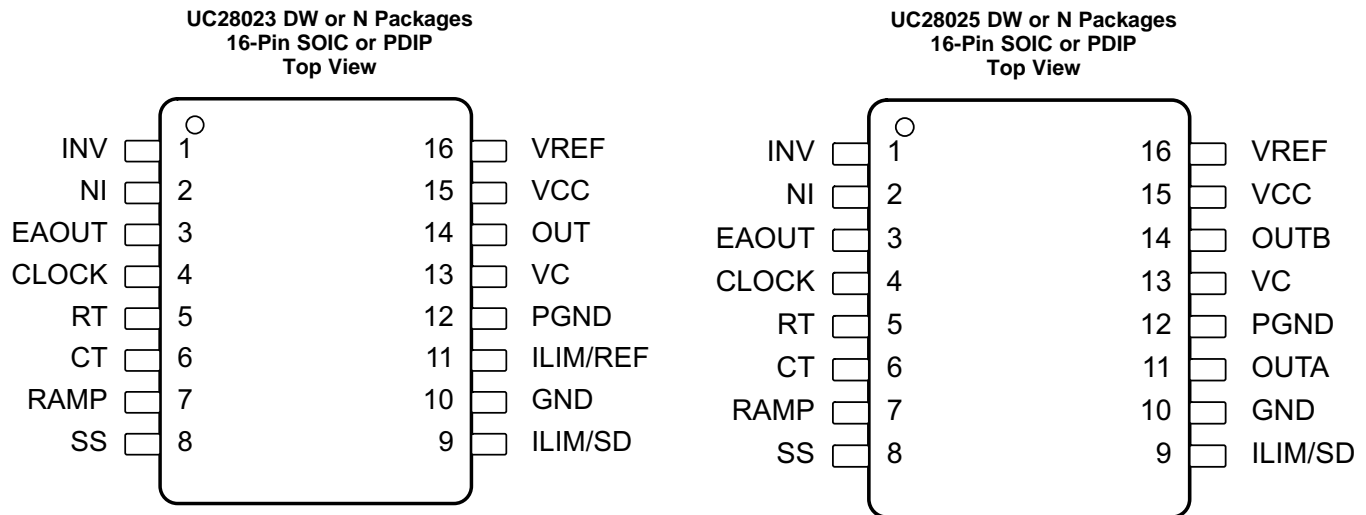

Pin Functions

NAME	PIN		I/O	DESCRIPTION
	UC28023	UC28025		
CLOCK	4	4	O	Output of the internal oscillator
CT	6	6	I	Timing capacitor connection pin for oscillator frequency programming. The timing capacitor must be connected to the device ground using minimal trace length.
EAOUT	3	3	O	Output of the error amplifier for compensation
GND	10	10	—	Analog ground return pin.
ILIM/REF	11	—	I	Pin to set the current limit threshold externally.
ILIM/SD	9	9	I	Input to the current limit comparator and the shutdown comparator.
INV	1	1	I	Inverting input to the error amplifier
NI	2	2	I	Noninverting input to the error amplifier
OUT	14	—	O	High current totem pole output of the on-chip drive stage.
OUTA	—	11	O	High current totem pole output A of the on-chip drive stage.
OUTB	—	14	O	High current totem pole output B of the on-chip drive stage
PGND	12	12	—	Ground return pin for the output driver stage
RAMP	7	7	I	Noninverting input to the PWM comparator with 1.25-V internal input offset. In voltage mode operation this serves as the input voltage feedforward function by using the CT ramp. In peak current mode operation, this serves as the slope compensation input.
RT	5	5	I	Timing resistor connection pin for oscillator frequency programming
SS	8	8	I	Soft-start input pin.
VC	13	13	—	Power supply pin for the output stage. This pin must be bypassed with a 0.1- μ F monolithic ceramic low ESL capacitor with minimal trace lengths.
VCC	15	15	—	Power supply pin for the device. This pin must be bypassed with a 0.1- μ F monolithic ceramic low ESL capacitor with minimal trace lengths
VREF	16	16	O	5.1-V reference. For stability, the reference must be bypassed with a 0.1- μ F monolithic ceramic low ESL capacitor and minimal trace length to the ground plane.

6 Specifications

6.1 Absolute Maximum Ratings

 over operating free-air temperature range (unless otherwise noted)⁽¹⁾⁽²⁾

		MIN	MAX	UNIT
Input voltage	VC, VCC		30	V
Analog inputs	INV, NI, RAMP	−0.3	7	V
	SS, ILIM/SD	$V_{REF} - 0.3$	$V_{REF} + 0.3$	
$I_{OUT(DC)}$	Output current		±0.5	A
	Peak output current, pulsed 0.5 ms (I_{OUT} pulsed)		±2	A
I_{REF}	Output current		10	mA
I_{CLOCK}	Output current		−5	mA
I_{SINK_SS}	Soft-start sink current		5	mA
$I_{OUT(EA)}$	Output current		20	mA
I_{OSC_CHG}	Oscillator charging current		−5	mA
C_{LOAD}	Capacitive load		200	pF
	Power Dissipation at $T_A = 25^\circ\text{C}$ (all packages)		1	W
T_J	Operating junction temperature	−55	150	°C
T_{stg}	Storage temperature	−65	150	°C

- (1) Stresses beyond those listed under *Absolute Maximum Ratings* may cause permanent damage to the device. These are stress ratings only, which do not imply functional operation of the device at these or any other conditions beyond those indicated under *Recommended Operating Conditions*. Exposure to absolute-maximum-rated conditions for extended periods may affect device reliability.
- (2) All voltages are with respect to GND. All currents are positive into and negative out of the specified terminal.

6.2 ESD Ratings

		VALUE	UNIT
$V_{(ESD)}$	Electrostatic discharge	Human-body model (HBM), per ANSI/ESDA/JEDEC JS-001 ⁽¹⁾	±3000
		Charged-device model (CDM), per JEDEC specification JESD22-C101 ⁽²⁾	±1500

- (1) JEDEC document JEP155 states that 500-V HBM allows safe manufacturing with a standard ESD control process.
- (2) JEDEC document JEP157 states that 250-V CDM allows safe manufacturing with a standard ESD control process.

6.3 Recommended Operating Conditions

over operating free-air temperature range (unless otherwise noted)

	MIN	NOM	MAX	UNIT
VCC input voltage from a low-impedance source		12		V
Operating temperature	−40		105	°C

6.4 Thermal Information

THERMAL METRIC ⁽¹⁾	UC2802x		UNIT	
	DW (SOIC)	N (PDIP)		
	16 PINS	16 PINS		
$R_{\theta JA}$	Junction-to-ambient thermal resistance	70.5	44.5	°C/W
$R_{\theta JC(top)}$	Junction-to-case (top) thermal resistance	31.8	34.3	°C/W
$R_{\theta JB}$	Junction-to-board thermal resistance	35.2	24.6	°C/W
Ψ_{JT}	Junction-to-top characterization parameter	7.7	14.7	°C/W
Ψ_{JB}	Junction-to-board characterization parameter	34.7	24.4	°C/W

- (1) For more information about traditional and new thermal metrics, see the *Semiconductor and IC Package Thermal Metrics* application report.

6.5 Electrical Characteristics

 $T_A = -40^\circ\text{C}$ to 105°C , $T_J = T_A$, $R_T = 3.65\text{ k}\Omega$, $C_T = 1\text{ nF}$, $V_{CC} = 15\text{ V}$ (unless otherwise noted)

PARAMETER		TEST CONDITIONS	MIN	TYP	MAX	UNIT
REFERENCE						
V_{REF}	Reference voltage	$T_J = 25^\circ\text{C}$, $I_{REF} = 1\text{ mA}$	5.05	5.1	5.15	V
	Line regulation voltage	$V_{CC} = 10\text{ V}$ to 30 V		2	15	mV
	Load regulation voltage	$I_{REF} = 1\text{ mA}$ to 10 mA		5	15	mV
	Temperature stability ⁽¹⁾	$T_A = -40^\circ\text{C}$ to 105°C		0.2	0.4	mV/ $^\circ\text{C}$
	Total output voltage variation ⁽¹⁾	Line and load temperature	4.95		5.25	V
	Output noise voltage ⁽¹⁾	$f = 10\text{ Hz}$ to 10 kHz		50		μV
	Long-term stability voltage ⁽¹⁾	$T_J = 125^\circ\text{C}$, 1000 hours		5	25	mV
I_{SS}	Short-circuit current	$V_{REF} = 0\text{ V}$	-20	-50	-100	mA
OSCILLATOR						
f_{OSC}	Initial accuracy ⁽¹⁾	$T_J = 25^\circ\text{C}$	360	400	440	kHz
	Voltage stability ⁽¹⁾	$V_{CC} = 10\text{ V}$ to 30 V		0.2%	2%	
	Temperature stability ⁽¹⁾	$T_A = -40^\circ\text{C}$ to 105°C		5%		
	Total voltage variation ⁽¹⁾	Line temperature	340		460	kHz
V_{CLOCK_H}	High-level clock output voltage		3.9	4.5		V
V_{CLOCK_L}	Low-level clock output voltage			2.3	2.9	V
$V_{RAMP(P)}$	Ramp peak voltage ⁽¹⁾		2.6	2.8	3	V
$V_{RAMP(V)}$	Ramp valley voltage ⁽¹⁾		0.7	1	1.25	V
$V_{RAMP(VP)}$	Ramp valley-to-peak voltage ⁽¹⁾		1.6	1.8	2	V
ERROR AMPLIFIER						
V_{IN}	Input offset voltage				15	mV
I_{BIAS}	Input bias current			0.6	3	μA
I_{IN}	Input offset current			0.1	1	μA
A_{VOL}	Open-loop gain	$V_{OUT} = 1\text{ V}$ to 4 V	60	95		dB
CMRR	Common-mode rejection ratio	$V_{CM} = 1.5\text{ V}$ to 5.5 V	75	95		dB
PSRR	Power supply rejection ratio	$V_{CC} = 10\text{ V}$ to 30 V	85	110		dB
$I_{OUT(SINK)}$	Output sink current	$V_{(EAOUT)} = 1\text{ V}$	1	2.5		mA
$I_{OUT(SRC)}$	Output source current	$V_{(EAOUT)} = 4\text{ V}$	-0.5	-1.3		mA
V_{OH}	High-level output voltage	$I_{(EAOUT)} = -0.5\text{ V}$	4	4.7	5	V
V_{OL}	Low-level output voltage	$I_{(EAOUT)} = 1\text{ mA}$	0	0.5	1	V
	Unity gain bandwidth ⁽¹⁾		3	5.5		MHz
	Slew rate ⁽¹⁾		6	12		V/ μs
PWM COMPARATOR						
I_{BIAS_RAMP}	RAMP bias current	$V_{RAMP} = 0\text{ V}$		-1	-5	μA
Maximum duty cycle	UC28023		80%	90%		
	UC28025	See ⁽²⁾	40%	45%		
Minimum duty cycle	UC28023				0%	
	UC28025				0%	
	EAOUT zero DC threshold	$V_{RAMP} = 0\text{ V}$	1.1	1.25	1.4	V
SOFT START						
I_{CHG}	Charge current	$V_{SS} = 0.5\text{ V}$	3	9	20	μA
I_{DISCHG}	Discharge current	$V_{SS} = 1\text{ V}$	1	7.5		mA

(1) Specified by design. Not production tested.

(2) Tested as 80% minimum for the oscillator which is the equivalent of 40% for UC28025.

Electrical Characteristics (continued)

 $T_A = -40^{\circ}\text{C}$ to 105°C , $T_J = T_A$, $R_T = 3.65\text{ k}\Omega$, $C_T = 1\text{ nF}$, $V_{CC} = 15\text{ V}$ (unless otherwise noted)

PARAMETER		TEST CONDITIONS	MIN	TYP	MAX	UNIT
CURRENT LIMIT AND SHUTDOWN						
I_{LIMIT}	Current limit bias current	$V_{ILIM/SD} = 0\text{ V to }4\text{ V}$			± 10	μA
I_{LIMIT}	Offset voltage	UC28023			15	mV
$I_{LIMITREF}$	Common mode ⁽¹⁾	UC28023	1		1.25	V
	Current limit threshold voltage	UC28025	0.9	1	1.1	V
	Shutdown threshold voltage		1.25	1.4	1.55	V
OUTPUT						
V_{OL}	Low-level output voltage	$I_{OUT} = 20\text{ mA}$		0.25	0.4	V
		$I_{OUT} = 200\text{ mA}$		1.2	2.2	
V_{OH}	High-level output voltage	$I_{OUT} = -20\text{ mA}$	13	13.5		V
		$I_{OUT} = -200\text{ mA}$	12	13		
	Collector leakage	$V_C = 30\text{ V}$	100	500		μA
UNDERVOLTAGE LOCKOUT (UVLO)						
	Start threshold voltage		8.8	9.2	9.6	V
	Hysteresis		0.4	0.8	1.2	V
SUPPLY CURRENT						
	Start-up current	$V_{CC} = 8\text{ V}$		1.1	2	mA
I_{CC}	Operating current	$V_{INV} = V_{RAMP} = V_{ILIM} = 0\text{ V}$, $V_{NI} = 1\text{ V}$		25	35	mA

6.6 Switching Characteristics

over operating free-air temperature range (unless otherwise noted)

PARAMETER		TEST CONDITIONS	MIN	TYP	MAX	UNIT
t_{DELAY}	Delay to output time ⁽¹⁾	PWM comparator		50	100	ns
		Current limit and shutdown		50	80	ns
	Rise time and Fall time ⁽¹⁾	$C_{LOAD} = 1\text{ nF}$	30	60		ns

(1) Specified by design. Not production tested.

6.7 Typical Characteristics

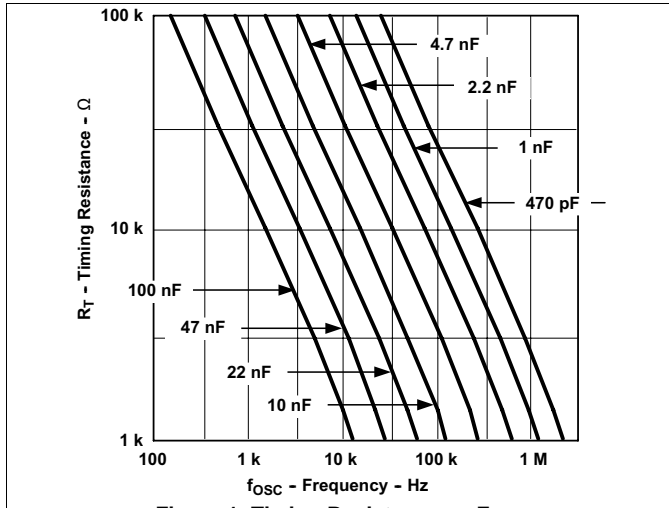

Figure 1. Timing Resistance vs Frequency

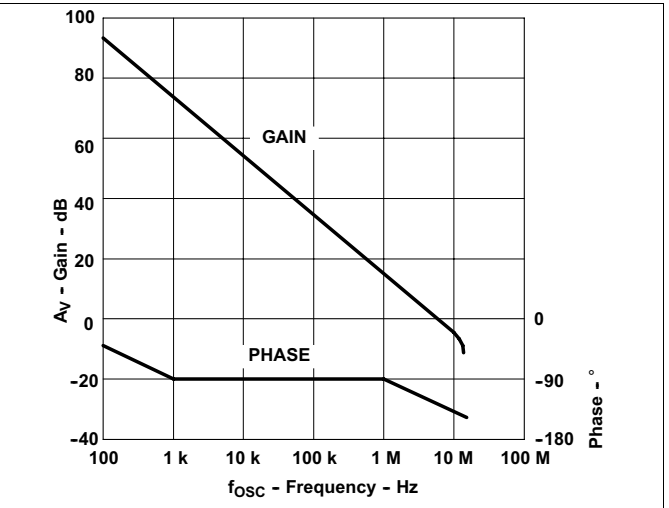

Figure 2. Open-Loop Frequency Response

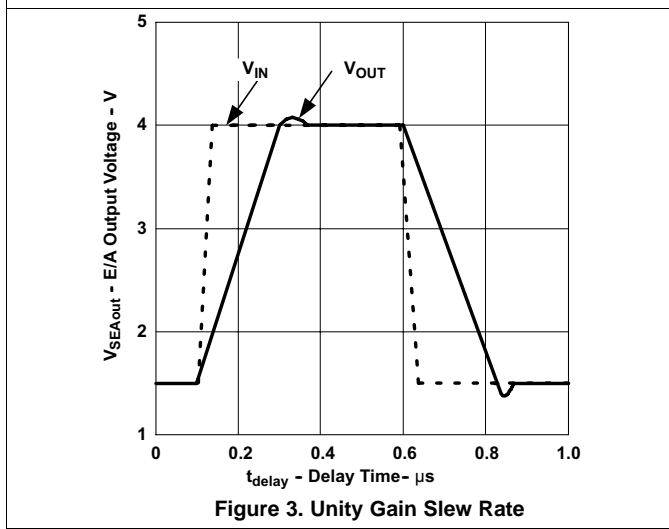

Figure 3. Unity Gain Slew Rate

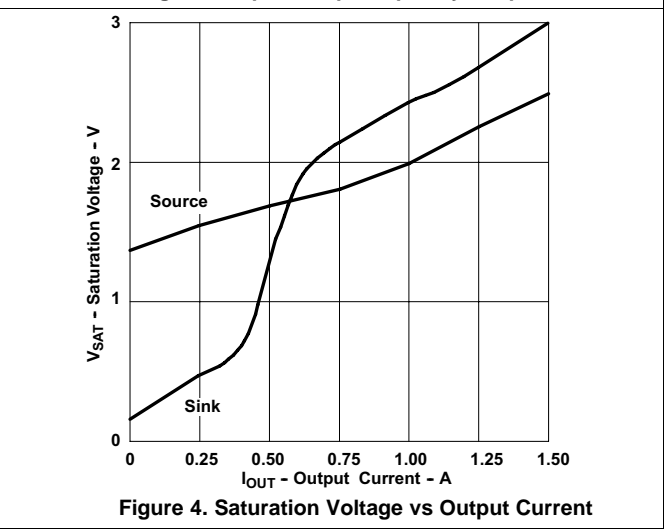

Figure 4. Saturation Voltage vs Output Current

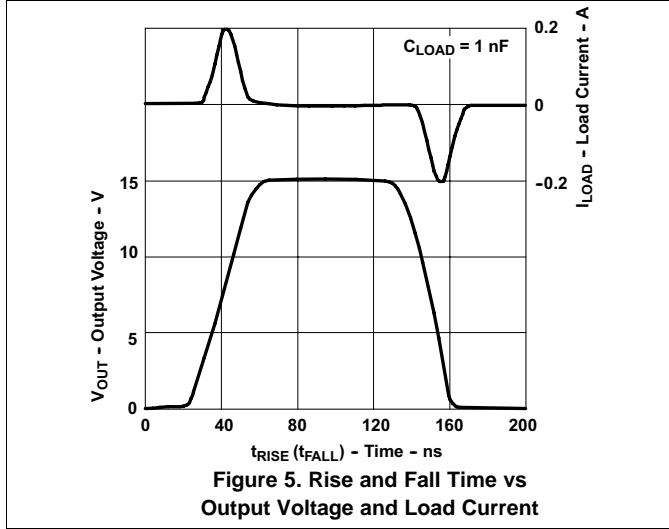

Figure 5. Rise and Fall Time vs Output Voltage and Load Current

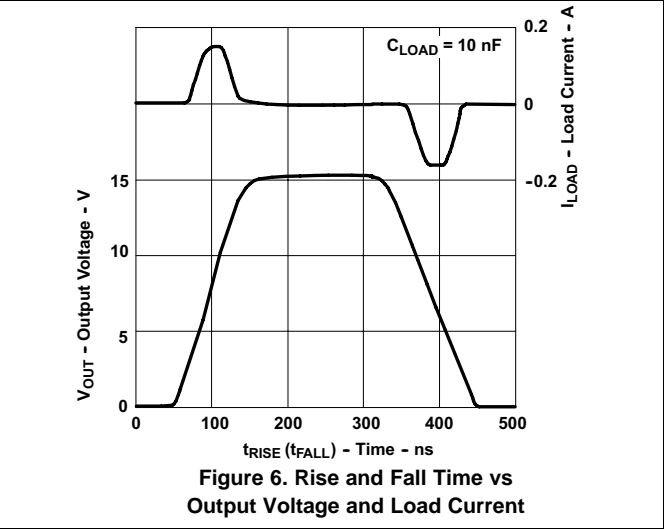

Figure 6. Rise and Fall Time vs Output Voltage and Load Current

7 Parameter Measurement Information

7.1 Control Methods and Test Circuits

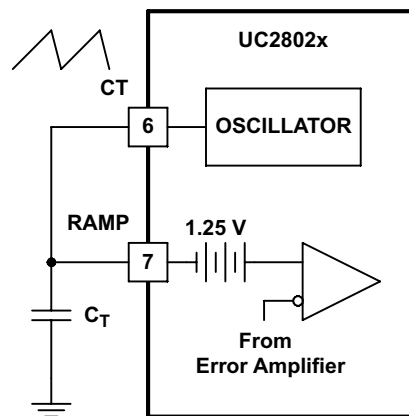
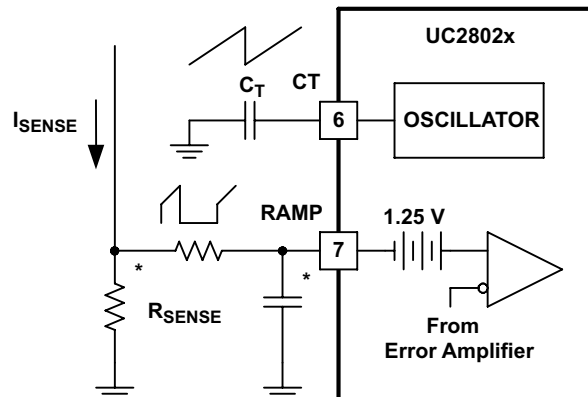

Figure 7. Voltage Mode Control



A small filter may be required to suppress switch noise.

Figure 8. Peak Current Mode Control

Control Methods and Test Circuits (continued)

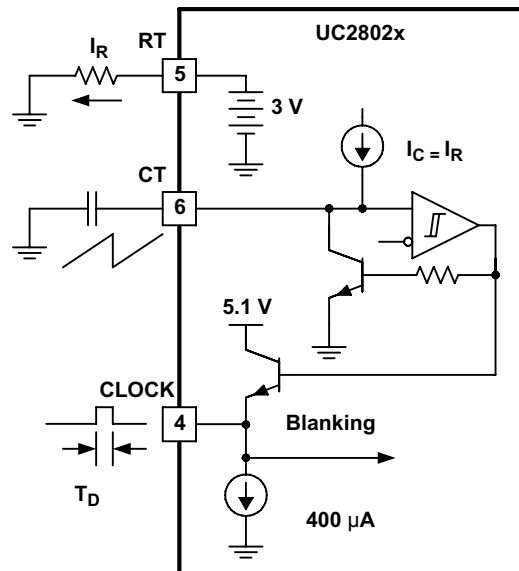

Figure 9. Oscillator Circuit

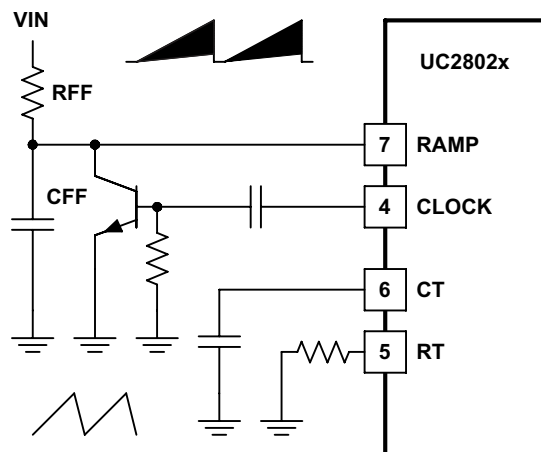

Figure 10. Feedforward Technique for Off-Line Voltage-Mode Applications

8 Detailed Description

8.1 Overview

The UC28023 and UC28025 (UC2802x) are fixed-frequency PWM controllers optimized for high-frequency switched-mode power-supply applications. Targeted for cost-effective solutions with minimal external components. UC2802x devices include an oscillator, a temperature-compensated reference, a wide band width error amplifier, a high-speed current-sense comparator, and high-current active-high totem-pole outputs to directly drive external MOSFETs.

Protection circuitry includes a current limit comparator with a 1-V threshold, a TTL compatible shutdown port, and a soft-start pin which doubles as a maximum duty cycle clamp. The logic is fully latched to provide jitter free operation and prohibit multiple pulses at an output. An undervoltage lockout section with 800 mV of hysteresis assures low start-up current. During undervoltage lockout, the outputs are high impedance. Propagation delays through the comparators and logic circuitry have been minimized while maximizing bandwidth and slew rate of the error amplifier.

8.2 Functional Block Diagram

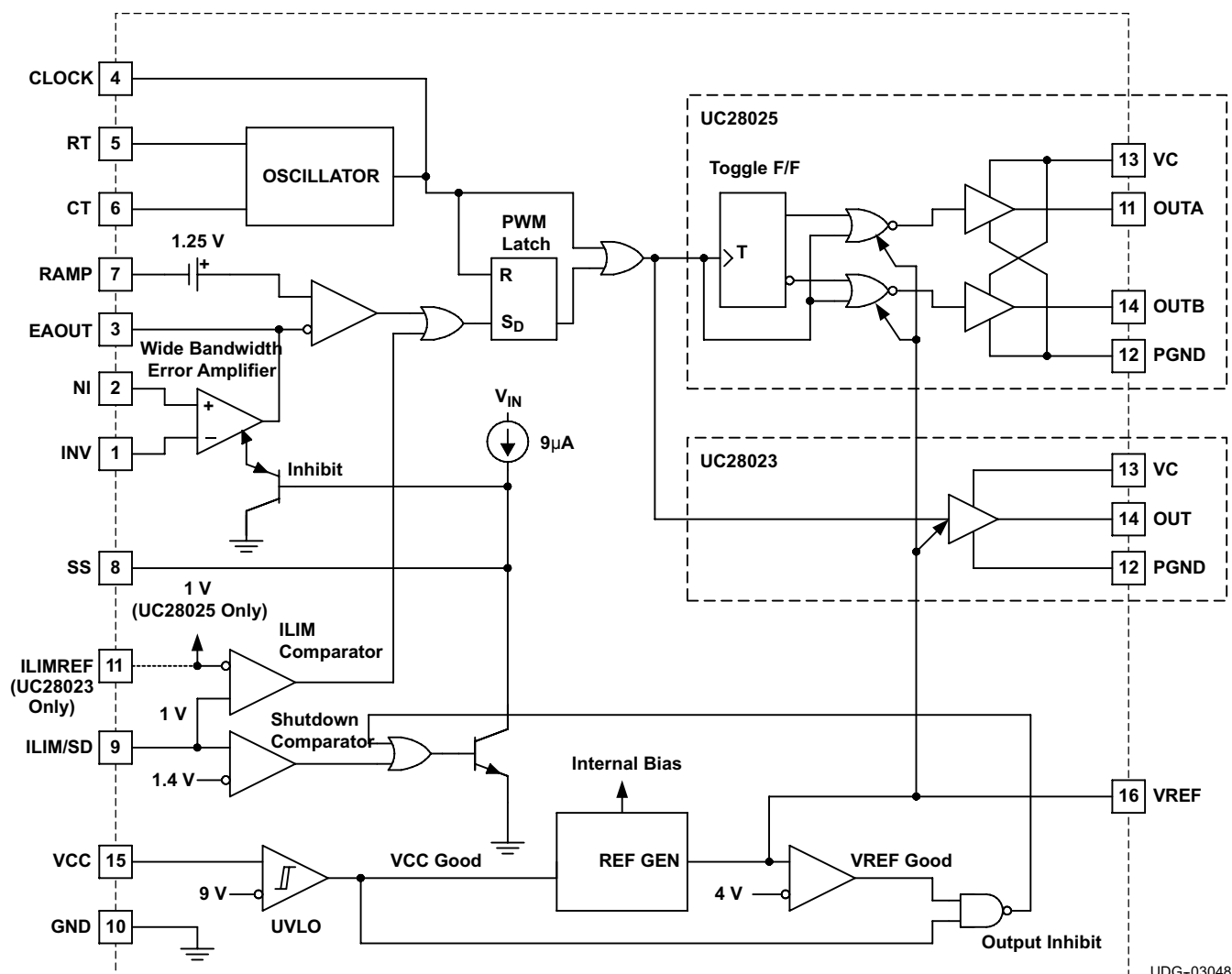

UDG-03048

Copyright © 2016, Texas Instruments Incorporated

8.3 Feature Description

8.3.1 Error Amplifier

Figure 11 shows a simplified schematic of the UC2802x error amplifier and Figure 2 and Figure 3 show its characteristics.

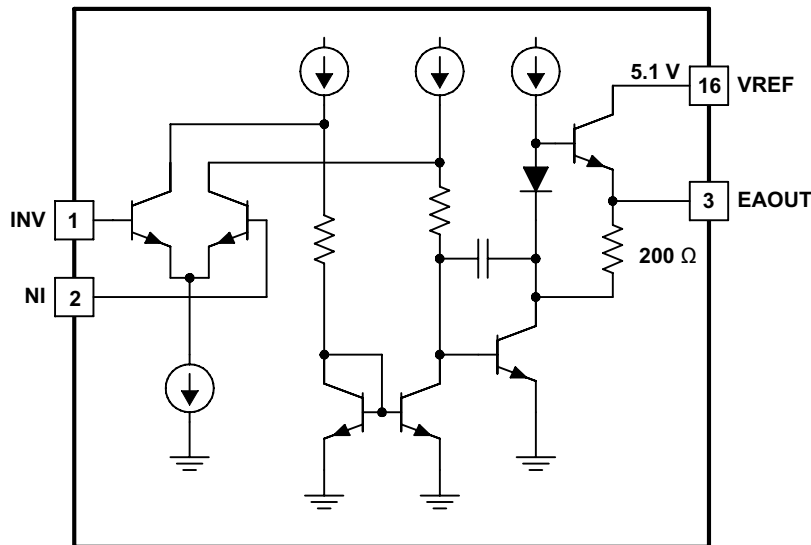

Copyright © 2016, Texas Instruments Incorporated

Figure 11. Simplified Error Amplifier Schematic

8.3.2 Synchronization

Figure 12 shows a generalized synchronization. Figure 13 shows a synchronized operation of two units in close proximity.

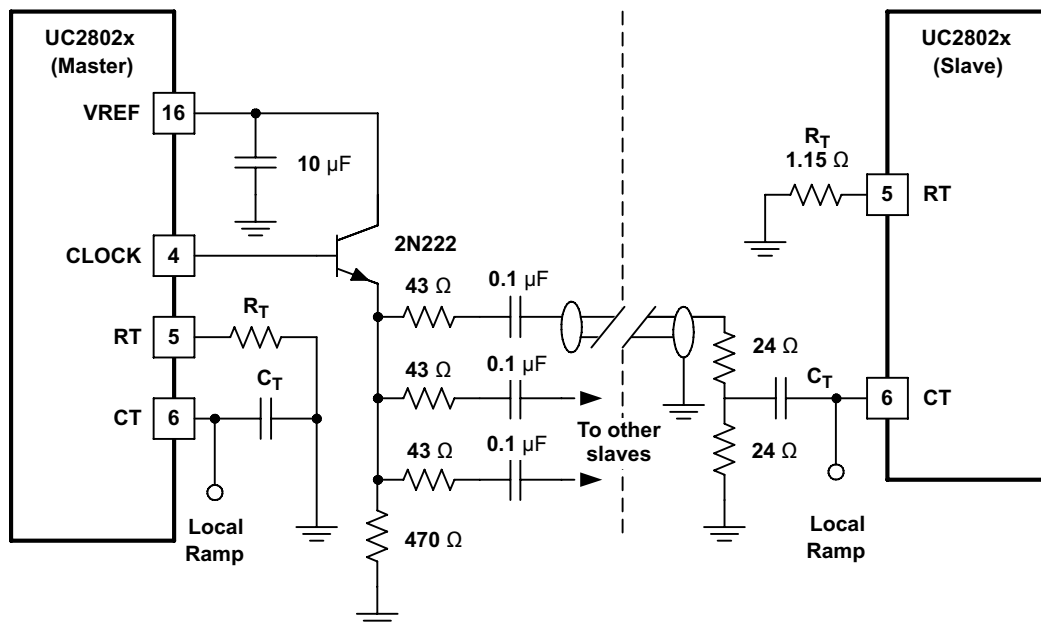

Copyright © 2016, Texas Instruments Incorporated

Figure 12. Generalized Synchronization

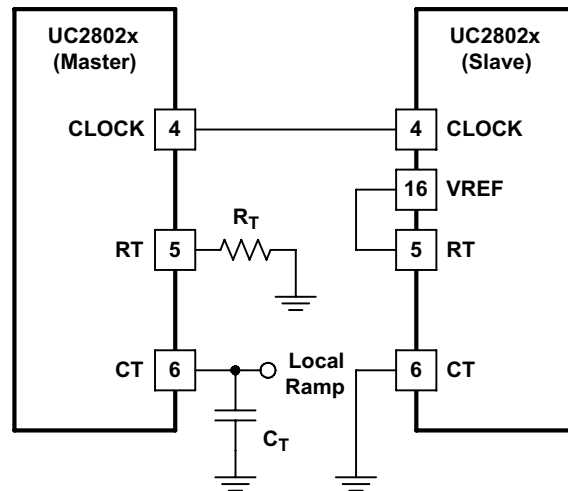
Feature Description (continued)

Copyright © 2016, Texas Instruments Incorporated

Figure 13. Synchronization of Two Units in Close Proximity
8.3.3 Constant Volt-Second Clamp Circuit

The circuit for the UC28023 shown in Figure 14 describes achievement a constant volt-second product clamp over varying input voltages. The ramp generator components, R_T and C_R are chosen so that the ramp at Pin 9 (ILIM/SD) crosses the 1-V threshold at the same time the desired maximum volt-second product is reached. The delay through the functional inverter block must be such that the ramp capacitor can be completely discharged during the minimum deadtime.

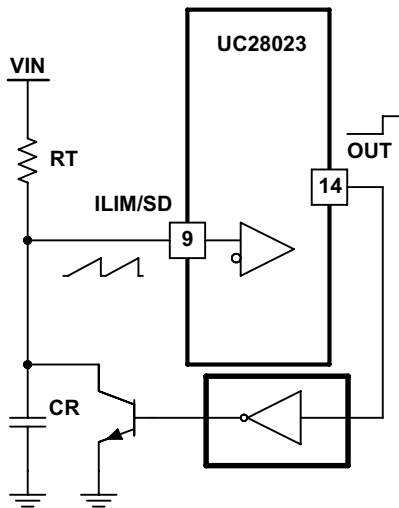

Copyright © 2016, Texas Instruments Incorporated

Figure 14. Achieving Constant Volt-Second Product Clamp With the UC28023

The circuit for the UC28025 shown in Figure 15 describes achievement a constant volt-second product clamp over varying input voltages. The ramp generator components, R_T and C_R are chosen so that the ramp at Pin 9 (ILIM/SD) crosses the 1-V threshold at the same time the desired maximum volt-second product is reached. The delay through the functional inverter block must be such that the ramp capacitor can be completely discharged during the minimum deadtime.

Feature Description (continued)

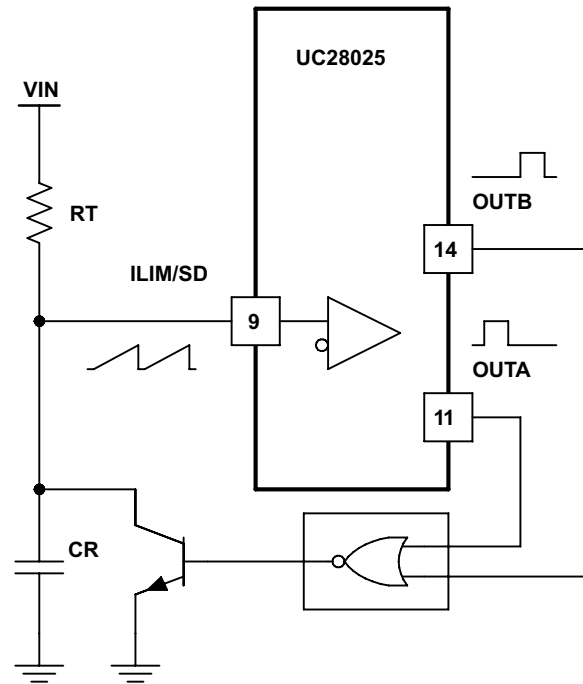

Copyright © 2016, Texas Instruments Incorporated

Figure 15. Achieving Constant Volt-Second Product Clamp With the UC28025

8.3.4 Outputs

UC28023 has one output and UC28025 has dual alternating outputs.

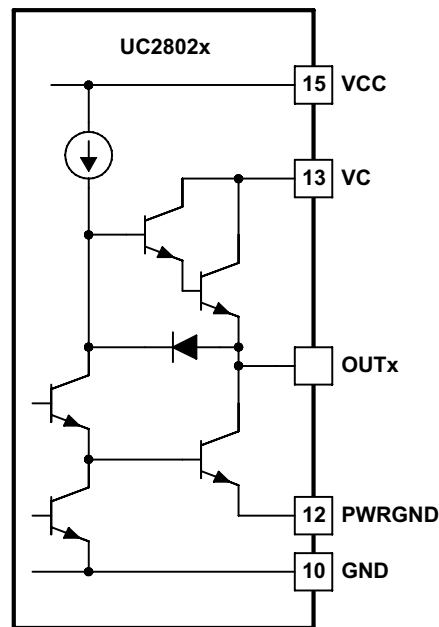

Copyright © 2016, Texas Instruments Incorporated

Figure 16. Simplified Schematic

Feature Description (continued)

8.3.5 Open-Loop Laboratory Test Fixture

The following test fixture is useful for exercising many of the UC28025's functions and measuring their specifications. As with any wideband circuit, careful ground and bypass procedures must be followed. TI highly recommends using a ground plane

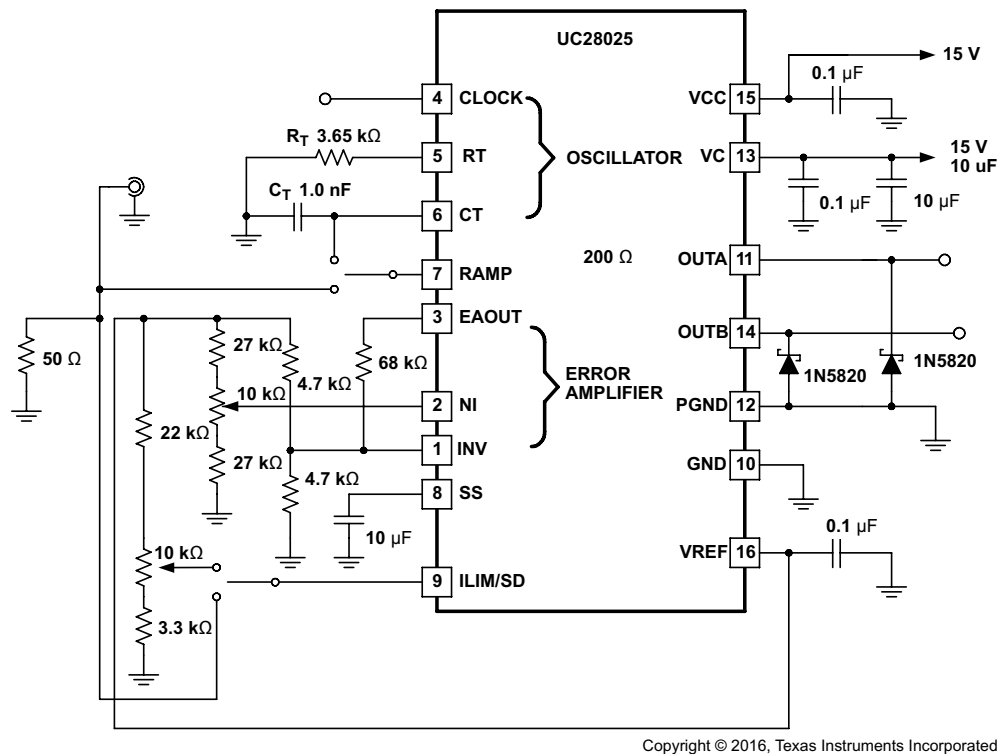

Figure 17. Laboratory Test Fixture

8.4 Device Functional Modes

There are no functional modes for this device.

9 Application and Implementation

NOTE

Information in the following applications sections is not part of the TI component specification, and TI does not warrant its accuracy or completeness. TI's customers are responsible for determining suitability of components for their purposes. Customers should validate and test their design implementation to confirm system functionality.

9.1 Application Information

The UC28023 and UC28025 are fixed-frequency PWM controllers optimized for high-frequency switched-mode power supply applications. The UC28023 is a single output PWM for single-ended topologies while the UC28025 offers dual alternating outputs for double-ended and full bridge topologies.

9.2 Typical Application

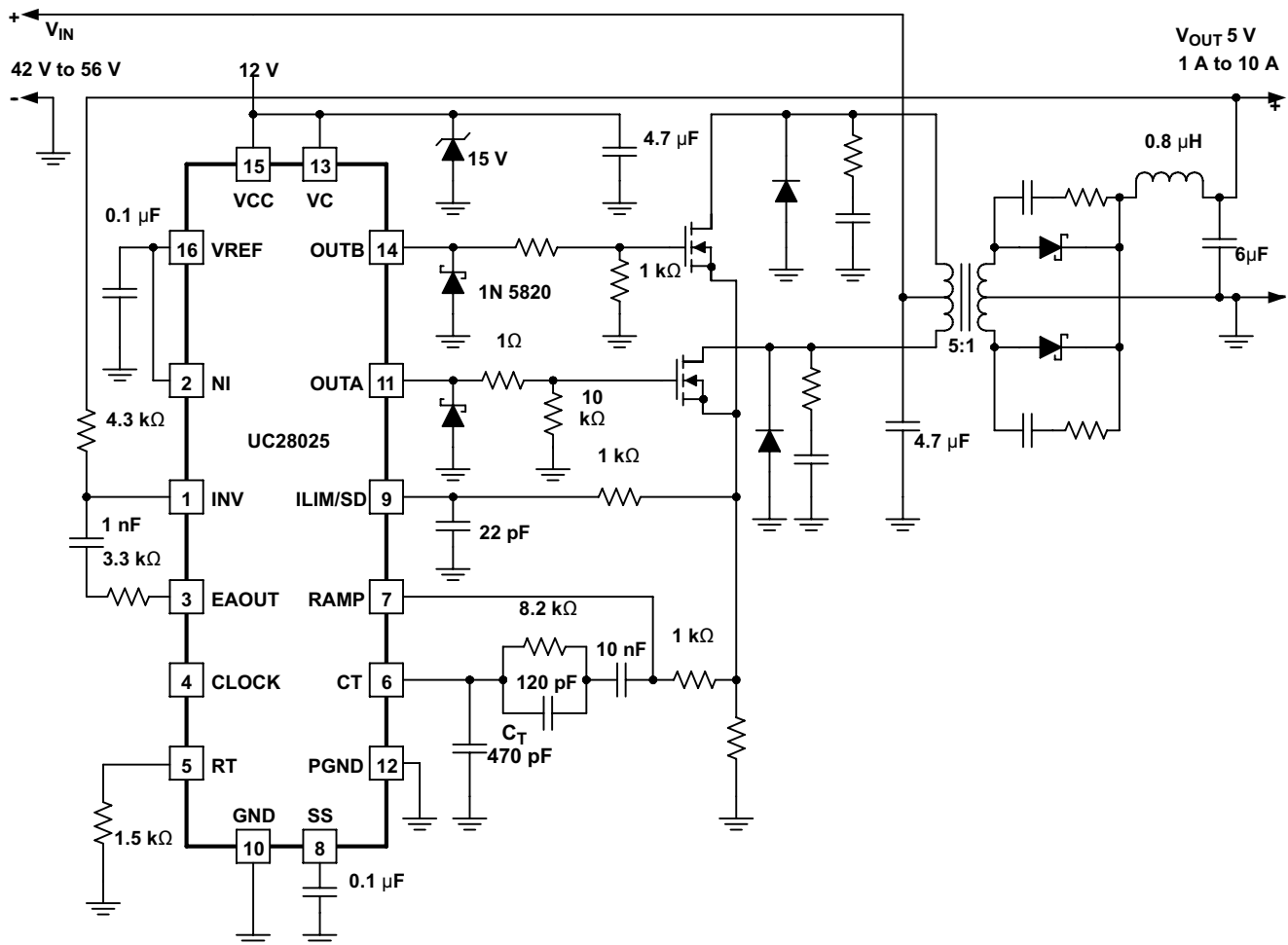

Copyright © 2016, Texas Instruments Incorporated

Figure 18. DC-DC Push-Pull Converter Using UC28025

Typical Application (continued)

9.2.1 Design Requirements

For this design example, use the parameters listed in [Table 1](#) as the input parameters.

Table 1. Design Parameters

PARAMETER	EXAMPLE VALUE
Input voltage	42 V to 56 V (48-V typical)
Output voltage	5 V
Output current	1 A to 10 A
Oscillator frequency	1.5 MHz
Switching frequency	750 kHz
Timing resistance	1.5 kΩ
Timing capacitance	470 pF

9.2.2 Detailed Design Procedure

9.2.2.1 Timing Resistor and Capacitor Selection

Generally, a higher switching frequency results in a smaller size but has higher switching losses. Operation at 750 kHz is used in this example as a reasonable compromise between size and efficiency. The values for timing resistance (R_T) and timing capacitance (C_T) are selected for the 1.5-MHz oscillator based on [Figure 1](#).

9.2.2.2 Turns Ratio Selection

The maximum primary-to-secondary turns ratio (N_{MAX}) can be determined with the target output voltage, minimum input voltage, and the estimated maximum duty cycle. $D_{LIM} = 0.35$ is used for this example. N_{MAX} can be calculated using [Equation 1](#).

$$N_{MAX} = \frac{2 \times D_{LIM} \times V_{INMIN}}{V_{OUT} + V_F} = \frac{2 \times 0.35 \times 42 \text{ V}}{5 \text{ V} + 0.3 \text{ V}} = 5.55 \quad (1)$$

Rounding N_{MAX} down to the next lowest integer results in a turns ratio of $N = 5$.

9.2.2.3 Inductor Selection

The maximum inductor ripple current occurs at the maximum input voltage. Typically, 20% to 40% of the full load current ripple is a good compromise between core loss and copper loss of the inductor. Higher ripple current allows for smaller inductor size, but places more burden on the output capacitor to smooth the ripple voltage on the output. In this example a ripple current of 25% of 10 A is used. The inductor value can be calculated with [Equation 2](#).

$$L_O = \frac{V_{OUT} + V_F}{\Delta I_L \times f_{SW}} \times \left(\frac{1}{2} - \frac{N \times (V_{OUT} + V_F)}{2 \times V_{INMAX}} \right) = 0.745 \mu\text{H} \quad (2)$$

The closest standard value of 0.8 μH is chosen for L_O , this step is necessary if the chosen L_O differs significantly from the value calculated in [Equation 2](#). The actual ΔI_L is based upon this selected inductor which must be calculated with [Equation 3](#).

$$\Delta I_L = \frac{V_{OUT} + V_F}{L_O \times f_{SW}} \times \left(\frac{1}{2} - \frac{N \times (V_{OUT} + V_F)}{2 \times V_{INMAX}} \right) = 2.327 \text{ A} \quad (3)$$

9.2.2.4 Rectifier Diode Selection

A rectifier diode must always possess low-forward voltage drop. When used in high-frequency switching applications, however, the diode must also possess a short recovery time. Schottky diodes meet both requirements and TI recommends their use for push-pull converter designs.

9.2.2.5 Snubber Components Selection

A resistor-capacitor snubber network crossing the low-side MOSFET reduces ringing and spikes at the switching node. Excessive ringing and spikes can cause erratic operation and may couple noise to the output voltage. Selecting the values for the snubber is best accomplished through empirical methods. First, make sure the lead lengths for the snubber connections are very short. Start with a resistor value between 5 Ω and 50 Ω. Increasing the value of the snubber capacitor results in more damping, but higher snubber losses. Select a minimum value for the snubber capacitor that provides adequate damping of the spikes on the switch node waveform at heavy load. A snubber may not be necessary with an optimized layout.

9.2.2.6 VCC and VC Capacitor Selection

The primary purpose of the VCC and VC capacitor is to supply the peak transient currents of the drivers as well as provide stability for the VCC and VC regulator. These peak currents can be several amperes. The value of the VCC and VC capacitor must at least 0.47 μF, and must be a good quality, low ESR, ceramic capacitor. The VCC and VC capacitor must be placed at the pins of the IC to minimize potentially damaging voltage transients caused by trace inductance. A value of 4.7 μF is used in this design.

9.2.2.7 Output Capacitor Selection

The output capacitors smooth the output voltage ripple caused by inductor ripple current and provide a source of charge during load transient conditions. In this design example, a 6-μF capacitor is selected as the main output capacitor.

9.2.2.8 Input Capacitor Selection

The input supply voltage typically has high source impedance at the switching frequency. Good quality input capacitors are necessary to limit the ripple voltage at the VIN pin while supplying most of the switch current during the on-time. The input capacitor must be selected for RMS current rating and minimum ripple voltage. In this example, a 4.7-μF capacitor is used. With ceramic capacitors, the input ripple voltage is triangular.

9.2.3 Application Curves

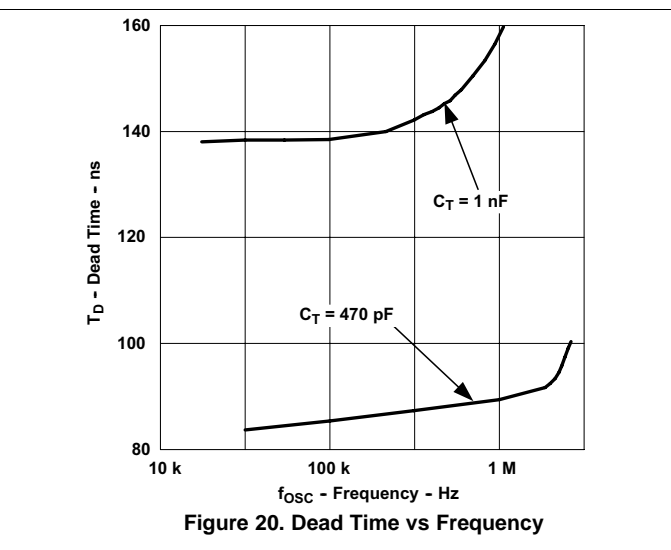
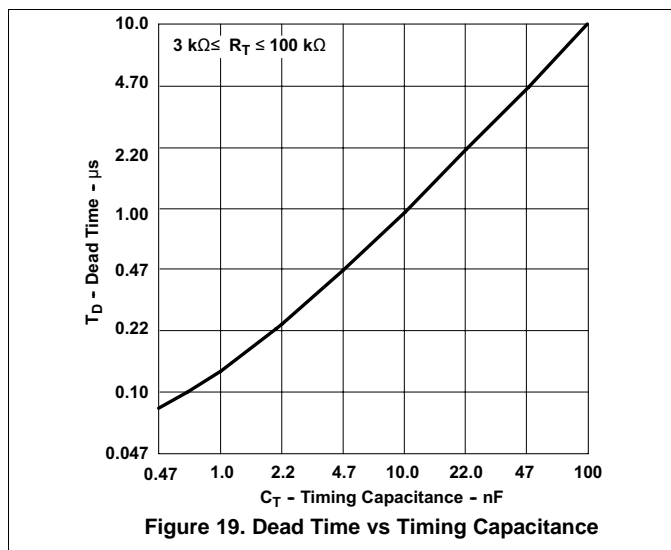

10 Power Supply Recommendations

The UC28023 and UC28025 operate from an external bias supply. TI recommends powering the device from a regulated auxiliary supply. (This device is not intended to be used from a bootstrap bias supply. A bootstrap bias supply is fed from the input high voltage through a resistor with sufficient capacitance on VCC to hold up the voltage on VCC until current can be supplied from a bias winding on the boost inductor. For that reason, the minimal hysteresis on VCC would require an unreasonable value of hold-up capacitance.)

11 Layout

11.1 Layout Guidelines

High speed circuits demand careful attention to layout and component placement. To assure proper performance of the UC2802x follow these rules:

1. Use a ground plane.
2. Damp or clamp parasitic inductive kick energy from the gate of driven MOSFETs. Do not allow the output pins to ring below ground. A series gate resistor or a shunt 1-A Schottky diode at the output pin serves this purpose.
3. Bypass VCC, VC, and VREF. Use 0.1- μ F monolithic ceramic capacitors with low equivalent series inductance. Allow less than 1 cm of total lead length for each capacitor between the bypassed pin and the ground plane.
4. Treat the timing capacitor (C_T) as a bypass capacitor.

11.2 Layout Example

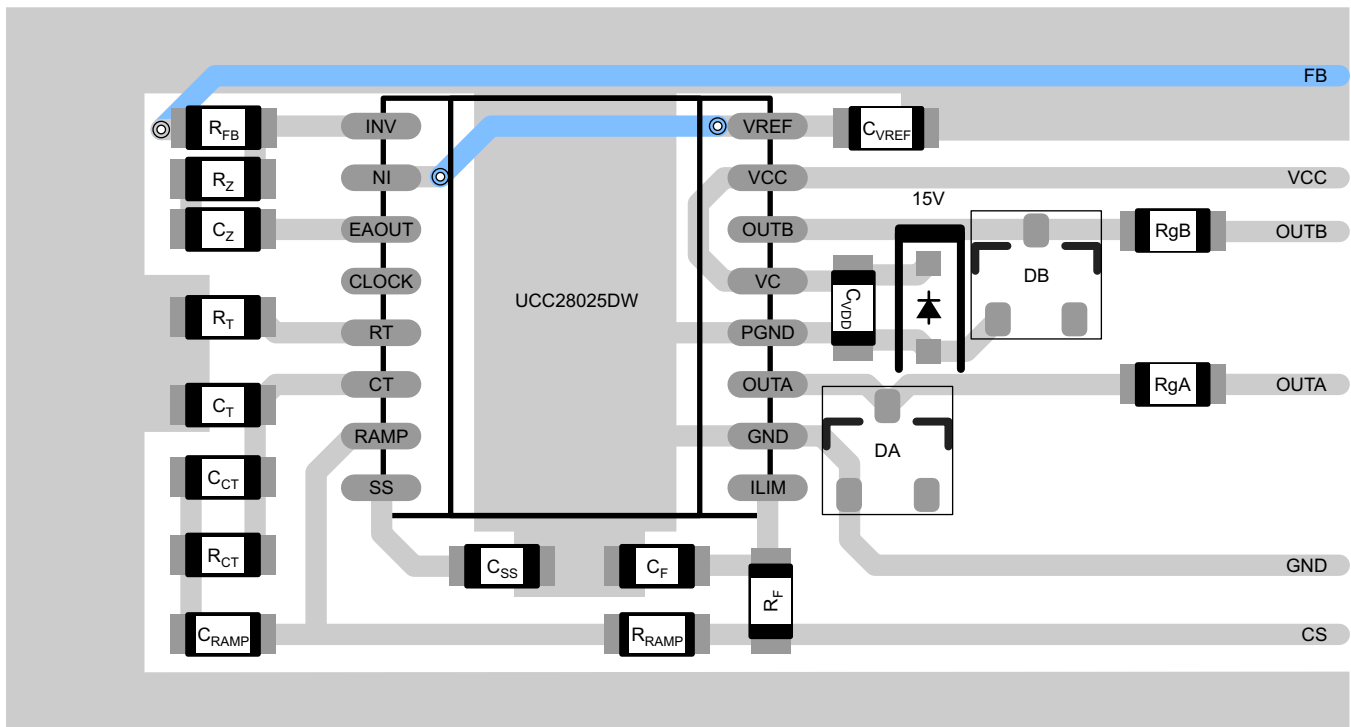

Figure 21. Layout Recommendation

12 Device and Documentation Support

12.1 Documentation Support

12.1.1 Related Documentation

For related documentation see the following:

- [1.5-MHz Current Mode IC Controlled 50--Watt Power Supply \(SLUA053\)](#)
- [The UC3823A,B and UC3825A,B Enhanced Generation of PWM Controllers \(SLUA125\)](#)

12.2 Related Links

The table below lists quick access links. Categories include technical documents, support and community resources, tools and software, and quick access to sample or buy.

Table 2. Related Links

PARTS	PRODUCT FOLDER	SAMPLE & BUY	TECHNICAL DOCUMENTS	TOOLS & SOFTWARE	SUPPORT & COMMUNITY
UC28023	Click here	Click here	Click here	Click here	Click here
UC28025	Click here	Click here	Click here	Click here	Click here

12.3 Receiving Notification of Documentation Updates

To receive notification of documentation updates, navigate to the device product folder on ti.com. In the upper right corner, click on *Alert me* to register and receive a weekly digest of any product information that has changed. For change details, review the revision history included in any revised document.

12.4 Community Resources

The following links connect to TI community resources. Linked contents are provided "AS IS" by the respective contributors. They do not constitute TI specifications and do not necessarily reflect TI's views; see TI's [Terms of Use](#).

TI E2E™ Online Community *TI's Engineer-to-Engineer (E2E) Community*. Created to foster collaboration among engineers. At e2e.ti.com, you can ask questions, share knowledge, explore ideas and help solve problems with fellow engineers.

Design Support *TI's Design Support* Quickly find helpful E2E forums along with design support tools and contact information for technical support.

12.5 Trademarks

E2E is a trademark of Texas Instruments.
All other trademarks are the property of their respective owners.

12.6 Electrostatic Discharge Caution



This integrated circuit can be damaged by ESD. Texas Instruments recommends that all integrated circuits be handled with appropriate precautions. Failure to observe proper handling and installation procedures can cause damage.

ESD damage can range from subtle performance degradation to complete device failure. Precision integrated circuits may be more susceptible to damage because very small parametric changes could cause the device not to meet its published specifications.

12.7 Glossary

[SLYZ022](#) — *TI Glossary*.

This glossary lists and explains terms, acronyms, and definitions.

13 Mechanical, Packaging, and Orderable Information

The following pages include mechanical, packaging, and orderable information. This information is the most current data available for the designated devices. This data is subject to change without notice and revision of this document. For browser-based versions of this data sheet, refer to the left-hand navigation.

PACKAGING INFORMATION

Orderable Device	Status (1)	Package Type	Package Drawing	Pins	Package Qty	Eco Plan (2)	Lead/Ball Finish (6)	MSL Peak Temp (3)	Op Temp (°C)	Device Marking (4/5)	Samples
UC28023DW	ACTIVE	SOIC	DW	16	40	Green (RoHS & no Sb/Br)	CU NIPDAU	Level-2-260C-1 YEAR	-40 to 105	UC28023DW	Samples
UC28023DWR	ACTIVE	SOIC	DW	16	2000	Green (RoHS & no Sb/Br)	CU NIPDAU	Level-2-260C-1 YEAR	-40 to 105	UC28023DW	Samples
UC28025DW	ACTIVE	SOIC	DW	16	40	Green (RoHS & no Sb/Br)	CU NIPDAU	Level-2-260C-1 YEAR	-40 to 105	UC28025DW	Samples
UC28025DWG4	ACTIVE	SOIC	DW	16	40	Green (RoHS & no Sb/Br)	CU NIPDAU	Level-2-260C-1 YEAR	-40 to 105	UC28025DW	Samples
UC28025DWR	ACTIVE	SOIC	DW	16	2000	Green (RoHS & no Sb/Br)	CU NIPDAU	Level-2-260C-1 YEAR	-40 to 105	UC28025DW	Samples
UC28025N	ACTIVE	PDIP	N	16	25	Green (RoHS & no Sb/Br)	CU NIPDAU	N / A for Pkg Type	-40 to 105	UC28025N	Samples
UC28025NG4	ACTIVE	PDIP	N	16	25	Green (RoHS & no Sb/Br)	CU NIPDAU	N / A for Pkg Type	-40 to 105	UC28025N	Samples

(1) The marketing status values are defined as follows:

ACTIVE: Product device recommended for new designs.

LIFEBUY: TI has announced that the device will be discontinued, and a lifetime-buy period is in effect.

NRND: Not recommended for new designs. Device is in production to support existing customers, but TI does not recommend using this part in a new design.

PREVIEW: Device has been announced but is not in production. Samples may or may not be available.

OBSOLETE: TI has discontinued the production of the device.

(2) **RoHS:** TI defines "RoHS" to mean semiconductor products that are compliant with the current EU RoHS requirements for all 10 RoHS substances, including the requirement that RoHS substance do not exceed 0.1% by weight in homogeneous materials. Where designed to be soldered at high temperatures, "RoHS" products are suitable for use in specified lead-free processes. TI may reference these types of products as "Pb-Free".

RoHS Exempt: TI defines "RoHS Exempt" to mean products that contain lead but are compliant with EU RoHS pursuant to a specific EU RoHS exemption.

Green: TI defines "Green" to mean the content of Chlorine (Cl) and Bromine (Br) based flame retardants meet JS709B low halogen requirements of <=100ppm threshold. Antimony trioxide based flame retardants must also meet the <=1000ppm threshold requirement.

(3) MSL, Peak Temp. - The Moisture Sensitivity Level rating according to the JEDEC industry standard classifications, and peak solder temperature.

(4) There may be additional marking, which relates to the logo, the lot trace code information, or the environmental category on the device.

(5) Multiple Device Markings will be inside parentheses. Only one Device Marking contained in parentheses and separated by a "-" will appear on a device. If a line is indented then it is a continuation of the previous line and the two combined represent the entire Device Marking for that device.

⁽⁶⁾ Lead/Ball Finish - Orderable Devices may have multiple material finish options. Finish options are separated by a vertical ruled line. Lead/Ball Finish values may wrap to two lines if the finish value exceeds the maximum column width.

Important Information and Disclaimer: The information provided on this page represents TI's knowledge and belief as of the date that it is provided. TI bases its knowledge and belief on information provided by third parties, and makes no representation or warranty as to the accuracy of such information. Efforts are underway to better integrate information from third parties. TI has taken and continues to take reasonable steps to provide representative and accurate information but may not have conducted destructive testing or chemical analysis on incoming materials and chemicals. TI and TI suppliers consider certain information to be proprietary, and thus CAS numbers and other limited information may not be available for release.

In no event shall TI's liability arising out of such information exceed the total purchase price of the TI part(s) at issue in this document sold by TI to Customer on an annual basis.

IMPORTANT NOTICE AND DISCLAIMER

TI PROVIDES TECHNICAL AND RELIABILITY DATA (INCLUDING DATASHEETS), DESIGN RESOURCES (INCLUDING REFERENCE DESIGNS), APPLICATION OR OTHER DESIGN ADVICE, WEB TOOLS, SAFETY INFORMATION, AND OTHER RESOURCES "AS IS" AND WITH ALL FAULTS, AND DISCLAIMS ALL WARRANTIES, EXPRESS AND IMPLIED, INCLUDING WITHOUT LIMITATION ANY IMPLIED WARRANTIES OF MERCHANTABILITY, FITNESS FOR A PARTICULAR PURPOSE OR NON-INFRINGEMENT OF THIRD PARTY INTELLECTUAL PROPERTY RIGHTS.

These resources are intended for skilled developers designing with TI products. You are solely responsible for (1) selecting the appropriate TI products for your application, (2) designing, validating and testing your application, and (3) ensuring your application meets applicable standards, and any other safety, security, or other requirements. These resources are subject to change without notice. TI grants you permission to use these resources only for development of an application that uses the TI products described in the resource. Other reproduction and display of these resources is prohibited. No license is granted to any other TI intellectual property right or to any third party intellectual property right. TI disclaims responsibility for, and you will fully indemnify TI and its representatives against, any claims, damages, costs, losses, and liabilities arising out of your use of these resources.

TI's products are provided subject to TI's Terms of Sale (www.ti.com/legal/termsofsale.html) or other applicable terms available either on ti.com or provided in conjunction with such TI products. TI's provision of these resources does not expand or otherwise alter TI's applicable warranties or warranty disclaimers for TI products.

Mailing Address: Texas Instruments, Post Office Box 655303, Dallas, Texas 75265
Copyright © 2018, Texas Instruments Incorporated

Looking for pricing, stock, or lifecycle information?

Click below to explore more details on WIN SOURCE:

 [View UC28023DWRG4](#) on WIN SOURCE

 [Texas Instruments](#) Information

Optimize Your Supply Chain with WIN SOURCE Solutions

-  Global Sourcing Solution
-  Obsolete Management
-  Cost Control Management
-  Shortage Management
-  Alternative Solution
-  Excess Inventory Management