



# THE DATASHEET OF STOD32ATPQR



## 300 mA triple DC-DC converter for powering AMOLED displays

Data brief

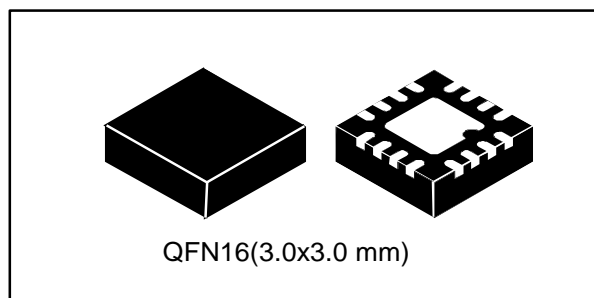

- Overtemperature protection
- True-shutdown mode
- Short-circuit protection
- Package QFN16 (3.0x3.0 mm), 0.5 mm pitch

### Applications

- Active matrix OLED power supply in portable devices
- Cellular phones, multimedia players, camcorders and digital still cameras

### Features

- Operating input voltage range from 2.5 V to 4.5 V
- 300 mA output current for step-up and inverting converters ( $V_{IN} > 2.9$  V)
- 55 mA output current for an auxiliary step-up converter ( $V_{IN} > 2.9$  V)
- 4.6 V positive step-up converter
- Programmable negative voltage from - 0.8 V to - 4.8 V default -4.0 V
- Auxiliary step-up converter positive voltage programmable step from 5.8 V to 7.9 V default 7.6 V
- Soft-start with inrush current protection

### Description

The STOD32A is a triple DC-DC converter for AMOLED display panels. It integrates 300 mA step-up and inverting DC-DC converters plus auxiliary step-up converter. This device is particularly suitable for battery operated products, in which the major concern is overall system efficiency. Output voltages can be programmed by a dedicated pin, which implements  $S_{WIRE}$  protocol. Soft-start with controlled inrush current limit, thermal shutdown and short-circuit protection are integrated functions of the device.

Table 1: Device summary

Order code	Positive voltage	Negative voltage	Auxiliary positive voltage	Package	Packing
STOD32ATPQR	4.6 V	-0.8 to 4.8 V	5.8 to 7.9 V	QFN16 (3x3 mm)	3000 samples per reel

---

## Contents

1	Application schematic .....	3
2	Package information .....	4
3	QFN16 (3.0x3.0 mm) package information.....	5
4	Revision history .....	7

# 1 Application schematic

Figure 1: Application schematic

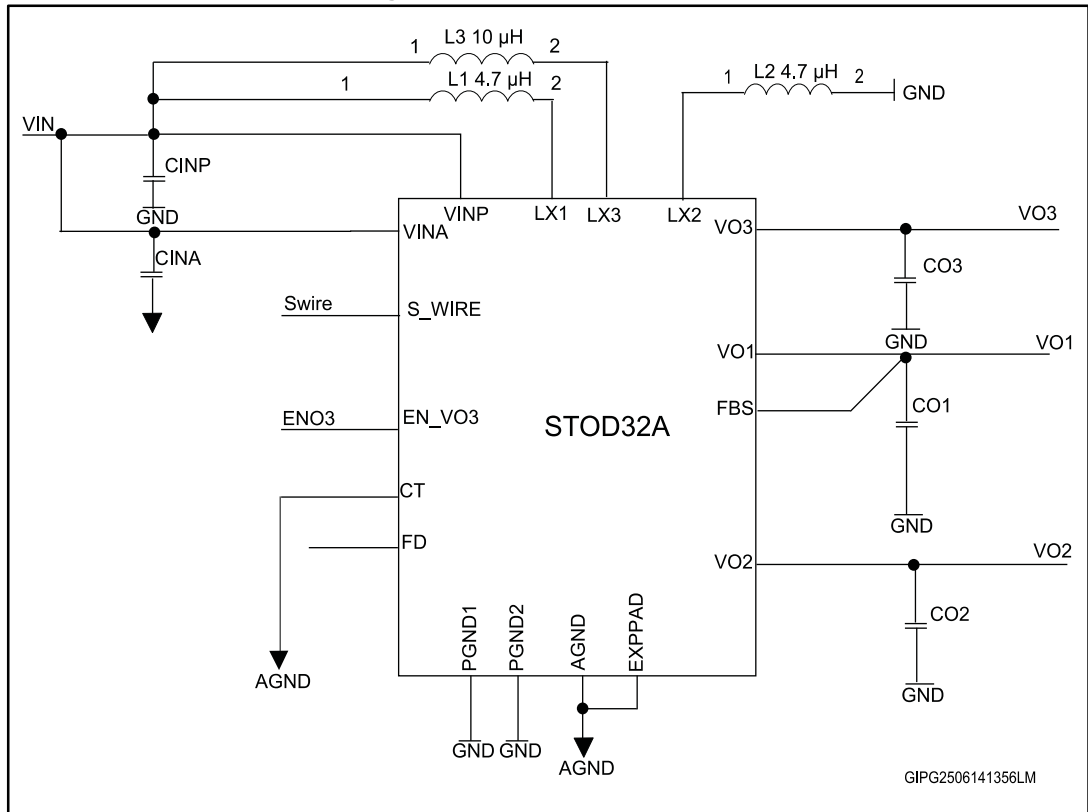

Table 2: Typical external components

Component	Manufacturer	Value	Size
L <sub>1</sub> , L <sub>2</sub> , L <sub>3</sub>	TOKO	4.7 μH	2.5x2.0x1.2
	ALPS		2.5x2.0x1.2
	COILCRAFT		4.0x4.0x1.2
C <sub>INA</sub> , C <sub>INP</sub> , C <sub>O2</sub> , C <sub>O3</sub>	MURATA	22 μF	0805
	SEMCO	10 μF	0402
			0603

## 2 Package information

In order to meet environmental requirements, ST offers these devices in different grades of ECOPACK® packages, depending on their level of environmental compliance. ECOPACK® specifications, grade definitions and product status are available at: [www.st.com](http://www.st.com). ECOPACK® is an ST trademark.

### 3 QFN16 (3.0x3.0 mm) package information

Figure 2: QFN16 (3.0x3.0 mm) package outline

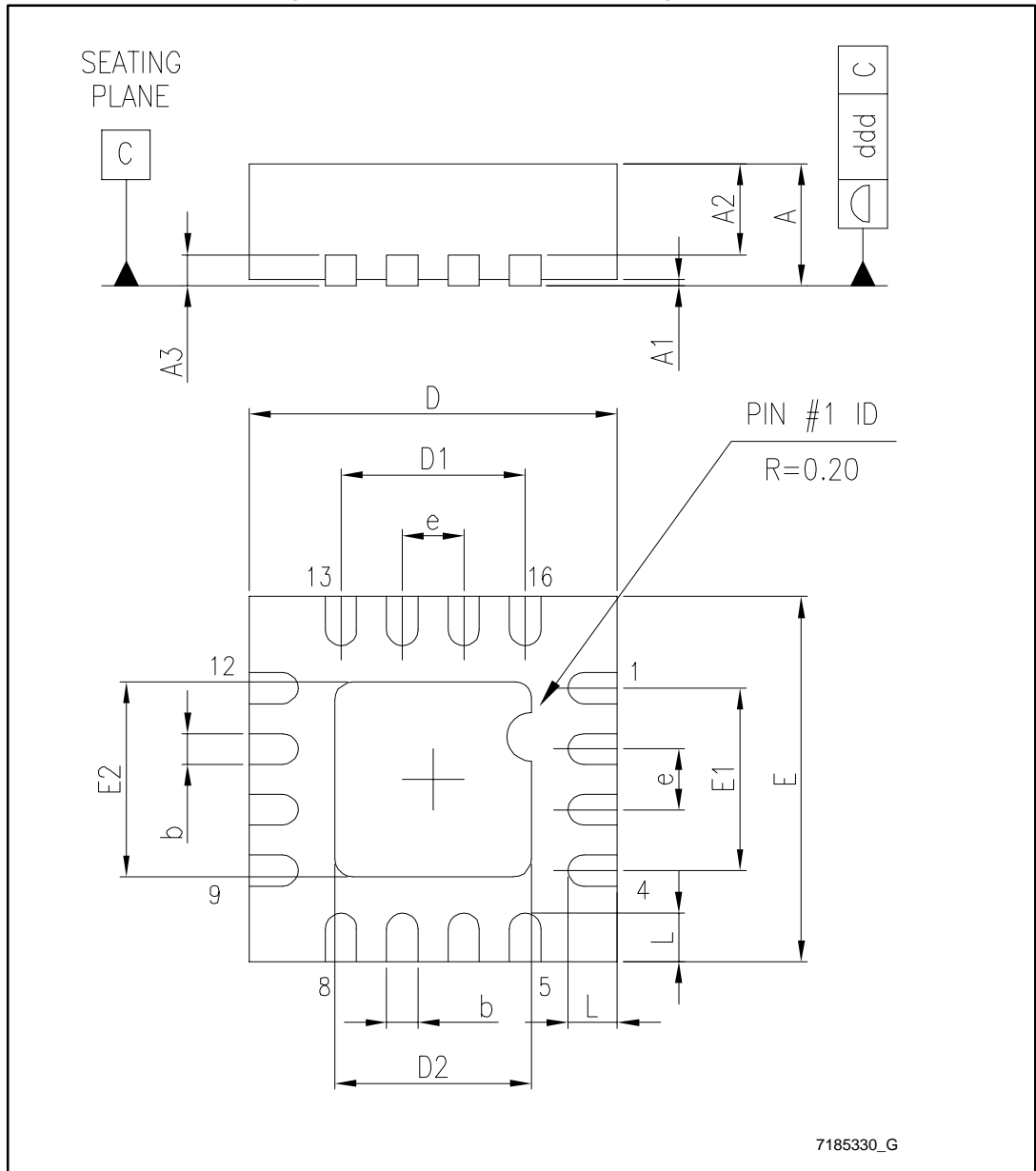
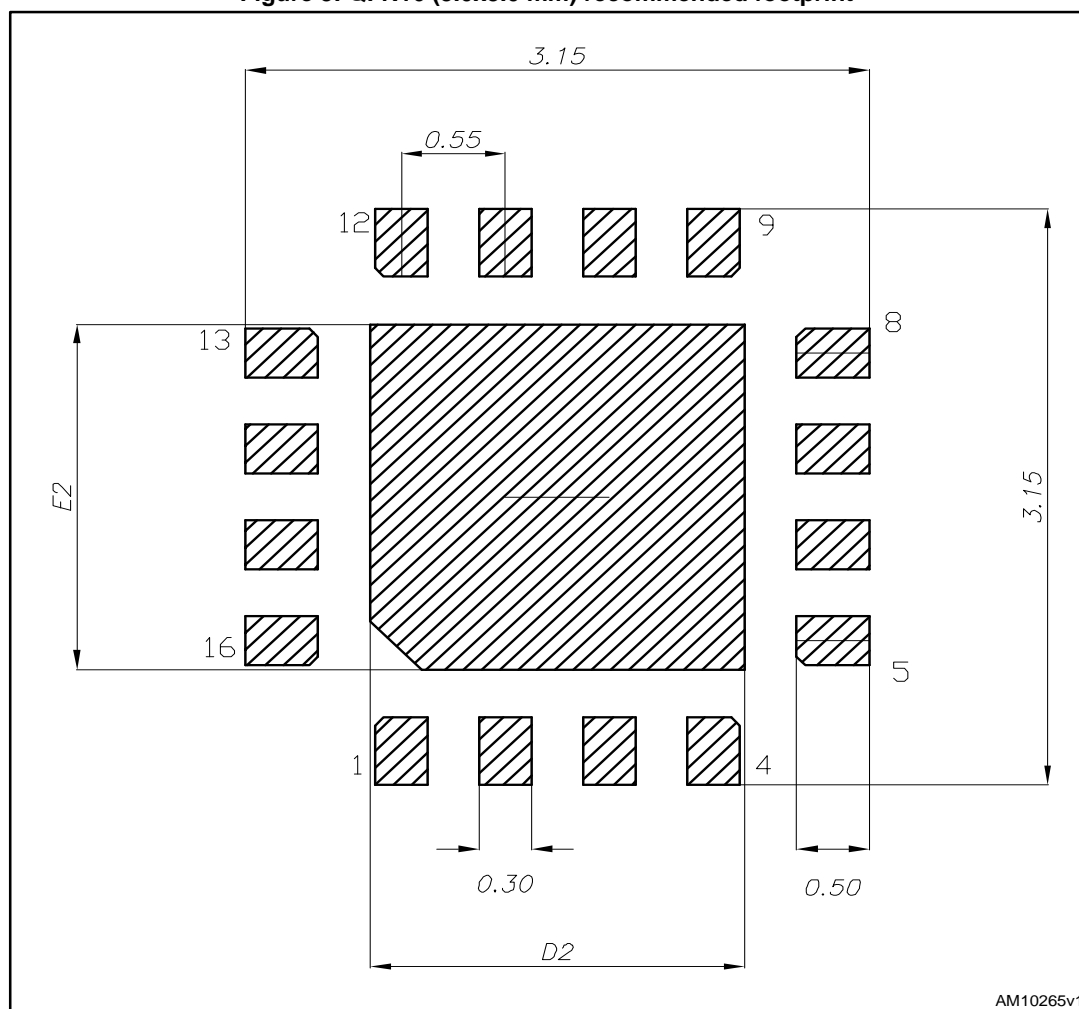

Table 3: QFN16 (3.0x3.0 mm) package mechanical data

Dim.	mm		
	Min.	Typ.	Max.
A	0.50	0.55	0.60
A1	0.00	0.02	0.05
b	0.20	0.25	0.30
D	2.9	3.00	3.1
D2	1.55	1.70	1.80
E	2.9	3.00	3.1
E2	1.55	1.70	1.80
e		0.50	
L	0.20	0.30	0.40

Figure 3: QFN16 (3.0x3.0 mm) recommended footprint



All dimensions are in mm

## 4 Revision history

Table 4: Document revision history

Date	Revision	Changes
16-Jul-2014	1	Initial release.
03-Nov-2015	2	Updated <a href="#">Table 3: "QFN16 (3.0x3.0 mm) package mechanical data"</a> .

**IMPORTANT NOTICE – PLEASE READ CAREFULLY**

STMicroelectronics NV and its subsidiaries ("ST") reserve the right to make changes, corrections, enhancements, modifications, and improvements to ST products and/or to this document at any time without notice. Purchasers should obtain the latest relevant information on ST products before placing orders. ST products are sold pursuant to ST's terms and conditions of sale in place at the time of order acknowledgement.

Purchasers are solely responsible for the choice, selection, and use of ST products and ST assumes no liability for application assistance or the design of Purchasers' products.

No license, express or implied, to any intellectual property right is granted by ST herein.

Resale of ST products with provisions different from the information set forth herein shall void any warranty granted by ST for such product.

ST and the ST logo are trademarks of ST. All other product or service names are the property of their respective owners.

Information in this document supersedes and replaces information previously supplied in any prior versions of this document.

© 2015 STMicroelectronics – All rights reserved

## Looking for pricing, stock, or lifecycle information?

Click below to explore more details on WIN SOURCE:

- ⊖ [View STOD32ATPQR on WIN SOURCE](#)
- ⊖ [STMicroelectronics Information](#)

## Optimize Your Supply Chain with WIN SOURCE Solutions

- ✓ Global Sourcing Solution
- ✓ Obsolete Management
- ✓ Cost Control Management
- ✓ Shortage Management
- ✓ Alternative Solution
- ✓ Excess Inventory Management