

OPAx365-Q1 50-MHz Low-Distortion High-CMRR Rail-to-Rail I/O, Single-Supply Operational Amplifiers

1 Features

- Qualified for Automotive Applications
- AEC-Q100 Qualified with the Following Results:
 - Device Temperature Grade 1: -40°C to 125°C Ambient Operating Temperature Range
 - Device HBM ESD Classification Level H2
 - Device CDM ESD Classification Level C3B
- Gain Bandwidth: 50 MHz
- Zero-Crossover Distortion Topology
 - Excellent THD+N: 0.0004%
 - CMRR: 100 dB (Minimum)
 - Rail-to-Rail Input and Output
 - Input 100 mV Beyond Supply Rail
- Low Noise: $4.5\text{ nV}/\sqrt{\text{Hz}}$ at 100 kHz
- Slew Rate: $25\text{ V}/\mu\text{s}$
- Fast Settling: $0.3\text{ }\mu\text{s}$ to 0.01%
- Precision
 - Low Offset: $100\text{ }\mu\text{V}$
 - Low Input Bias Current: 0.2 pA
- 2.2-V to 5.5-V Operation

2 Applications

- Automotive
- ADAS
- HEV/EV and Powertrain
- Body and Lighting
- Blind Spot Detection
- Engine Control Units
- DC-DC Converters
- Short to Mid Range Radars
- Collision Warning
- Industrial
- Heads Up Display

3 Description

The OPAx365-Q1 zero-crossover family, rail-to-rail, high-performance, CMOS operational amplifiers are optimized for very low voltage, single-supply applications. Rail-to-rail input/output, low noise ($4.5\text{ nV}/\sqrt{\text{Hz}}$) and high speed operation (50-MHz gain bandwidth) make these devices ideal for driving sampling data converters (such as the ADS7822-Q1 or the ADS1115-Q1), specifically in short to mid-range radar applications. The OPAx356-Q1 family of operational amplifiers are also well-suited for HEV/EV and Powertrain applications in DC-DC converters and as transmission control in engine control units.

Device Information⁽¹⁾

PART NUMBER	PACKAGE	BODY SIZE (NOM)
OPA2365-Q1	SOIC (8)	4.90 mm x 3.91 mm
OPA365-Q1	SOT-23 (5)	2.90 mm x 1.60 mm

(1) For all available packages, see the orderable addendum at the end of the data sheet.

Fast-Settling Peak Detector

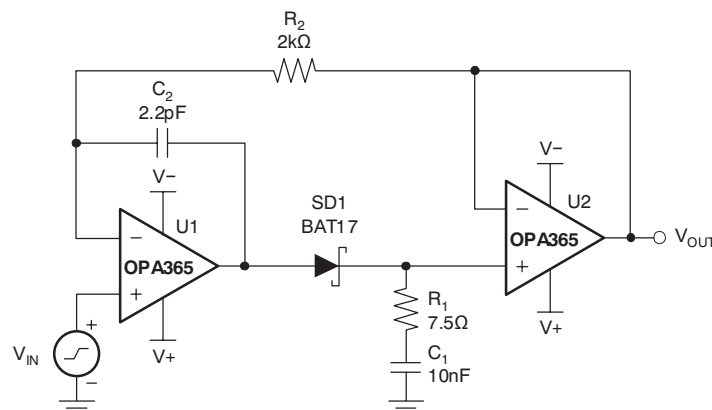

Table of Contents

1 Features 1 2 Applications 1 3 Description 1 4 Revision History 2 5 Description (Continued) 3 6 Pin Configuration and Functions 3 7 Specifications 4 7.1 Absolute Maximum Ratings 4 7.2 ESD Ratings..... 4 7.3 Recommended Operating Conditions 4 7.4 Thermal Information 4 7.5 Electrical Characteristics..... 5 7.6 Typical Characteristics 7 8 Detailed Description 11 8.1 Overview 11 8.2 Functional Block Diagram 11 8.3 Feature Description..... 12	8.4 Device Functional Modes..... 13 9 Application and Implementation 14 9.1 Application Information..... 14 9.2 Typical Application 17 10 Power Supply Recommendations 20 11 Layout 20 11.1 Layout Guidelines 20 11.2 Layout Example 20 12 Device and Documentation Support 21 12.1 Documentation Support 21 12.2 Related Links 21 12.3 Community Resources..... 21 12.4 Trademarks 21 12.5 Electrostatic Discharge Caution..... 21 12.6 Glossary 21 13 Mechanical, Packaging, and Orderable Information 21
--	---

4 Revision History

NOTE: Page numbers for previous revisions may differ from page numbers in the current version.

Changes from Revision C (April 2012) to Revision D	Page
<ul style="list-style-type: none"> • Added <i>ESD Ratings</i> table, <i>Feature Description</i> section, <i>Device Functional Modes</i>, <i>Application and Implementation</i> section, <i>Power Supply Recommendations</i> section, <i>Layout</i> section, <i>Device and Documentation Support</i> section, and <i>Mechanical, Packaging, and Orderable Information</i> section 	1

Changes from Revision B (January 2012) to Revision C	Page
<ul style="list-style-type: none"> • Added another row with V_{OS} for OPA2365-Q1 only • Changed I_Q upper limit to 5.3 from 5.5 	5 6

5 Description (Continued)

Special features include an excellent common-mode rejection ratio (CMRR), no input stage crossover distortion, high input impedance, and rail-to-rail input and output swing. The input common-mode range includes both the negative and positive supplies. The output voltage swing is within 10 mV of the rails.

The OPA365-Q1 (single version) is available in the 5-pin SOT-23 package. The OPA2365-Q1 (dual version) is available in the 8-pin SOIC package. All versions are specified for operation from -40°C to 125°C . Single and dual versions have identical specifications for maximum design flexibility.

6 Pin Configuration and Functions



Pin Functions

NAME	PIN		I/O	DESCRIPTION
	SOT-23	SOIC		
+IN	3	—	I	Noninverting input
-IN	4	—	I	Inverting input
+IN A	—	3	I	Noninverting input
-IN A	—	2	I	Inverting input
+IN B	—	5	I	Noninverting input
-IN B	—	6	I	Inverting input
$V+$	5	8	I	Positive (highest) supply
$V-$	4	4	I	Negative (lowest) supply
V_{OUT}	1	—	O	Output
V_{OUTA}	—	1	O	Output
V_{OUTB}	—	7	O	Output

7 Specifications

7.1 Absolute Maximum Ratings

 over operating free-air temperature range (unless otherwise noted)⁽¹⁾

		MIN	MAX	UNIT
V _{CC}	Supply voltage		5.5	V
V _I	Signal input terminals, voltage ⁽²⁾	(V ₋) - 0.5	(V ₊) + 0.5	V
I _I	Signal input terminals, current ⁽²⁾	-10	10	mA
t _{OSC}	Output short-circuit duration ⁽³⁾	Continuous		
T _{OP}	Operating temperature	-40	150	°C
T _J	Junction temperature		150	°C
T _{stg}	Storage temperature	-65	150	°C

- (1) Stresses beyond those listed under *Absolute Maximum Ratings* may cause permanent damage to the device. These are stress ratings only, which do not imply functional operation of the device at these or any other conditions beyond those indicated under *Recommended Operating Conditions*. Exposure to absolute-maximum-rated conditions for extended periods may affect device reliability.
- (2) Input terminals are diode-clamped to the power-supply rails. Input signals that can swing more than 0.5V beyond the supply rails should be current-limited to 10 mA or less.
- (3) Short-circuit to ground, one amplifier per package

7.2 ESD Ratings

		VALUE	UNIT
V _(ESD)	Electrostatic discharge	Human-body model (HBM), per AEC Q100-002 ⁽¹⁾	±2000
		Charged-device model (CDM), per AEC Q100-011	±750

- (1) AEC Q100-002 indicates that HBM stressing shall be in accordance with the ANSI/ESDA/JEDEC JS-001 specification.

7.3 Recommended Operating Conditions

over operating free-air temperature range (unless otherwise noted)

		MIN	NOM	MAX	UNIT
V _S	Supply voltage V ₋ to V ₊	2.2	3.3	5.5	V
T _A	Operating free-air temperature	-40	25	125	°C

7.4 Thermal Information

THERMAL METRIC ⁽¹⁾		OPA2365-Q1	OPA365-Q1	UNIT
		D (SOIC)	DBV (SOT-23)	
		8 PINS	5 PINS	
R _{θJA}	Junction-to-ambient thermal resistance	115.5	208.8	°C/W
R _{θJC(top)}	Junction-to-case (top) thermal resistance	60.1	123.7	°C/W
R _{θJB}	Junction-to-board thermal resistance	56.9	54.6	°C/W
ψ _{JT}	Junction-to-top characterization parameter	9.5	37.2	°C/W
ψ _{JB}	Junction-to-board characterization parameter	56.3	36.3	°C/W

- (1) For more information about traditional and new thermal metrics, see the *Semiconductor and IC Package Thermal Metrics* application report, [SPRA953](#).

7.5 Electrical Characteristics

$V_S = 2.2\text{ V to }5.5\text{ V}$, $R_L = 10\text{ k}\Omega$ connected to $V_S/2$, $V_{CM} = V_S/2$, and $V_{OUT} = V_S/2$ (unless otherwise noted)

PARAMETER		TEST CONDITIONS	T_A ⁽¹⁾	MIN	TYP	MAX	UNIT
OFFSET VOLTAGE							
V_{OS}	Input offset voltage		25°C		100	200	μV
$V_{OS}^{(2)}$	Input offset voltage		25°C		100	230	μV
$\frac{dV_{OS}}{dT}$	Input offset voltage drift		Full range		1		$\mu\text{V}/^\circ\text{C}$
PSRR	Input offset voltage vs power supply	$V_S = 2.2\text{ V to }5.5\text{ V}$	Full range		10	100	$\mu\text{V}/\text{V}$
	Channel separation, DC		25°C		0.2		$\mu\text{V}/\text{V}$
INPUT BIAS CURRENT							
I_B	Input bias current		25°C		± 0.2	± 10	pA
			Full range		See Typical Characteristics		
I_{OS}	Input offset current		25°C		± 0.2	± 10	pA
NOISE							
e_n	Input voltage noise	$f = 0.1\text{ Hz to }10\text{ Hz}$	25°C		5		μV_{PP}
e_n	Input voltage noise density	$f = 100\text{ kHz}$	25°C		4.5		$\text{nV}/\sqrt{\text{Hz}}$
i_n	Input current noise density	$f = 10\text{ kHz}$	25°C		4		$\text{fA}/\sqrt{\text{Hz}}$
INPUT VOLTAGE RANGE							
V_{CM}	Common-mode voltage		25°C	$(V_-) - 0.1$		$(V_+) + 0.1$	V
CMRR	Common-mode rejection ratio	$(V_-) - 0.1\text{ V} \leq V_{CM} \leq (V_+) + 0.1\text{ V}$	Full range	100	120		dB
INPUT CAPACITANCE							
	Differential		25°C		6		pF
	Common-mode		25°C		2		pF
OPEN-LOOP GAIN							
A_{OL}	Open-loop voltage gain	$R_L = 10\text{ k}\Omega$, $100\text{ mV} < V_O < (V_+) - 100\text{ mV}$	Full range	100	120		dB
		$R_L = 600\ \Omega$, $200\text{ mV} < V_O < (V_+) - 200\text{ mV}$	25°C	100	120		
		$R_L = 600\ \Omega$, $200\text{ mV} < V_O < (V_+) - 200\text{ mV}$	Full range	94			
FREQUENCY RESPONSE							
GBW	Gain-bandwidth product		25°C		50		MHz
SR	Slew rate	$V_S = 5\text{ V}$, $G = 1$	25°C		25		$\text{V}/\mu\text{s}$
t_s	Settling time	0.1%, $V_S = 5\text{ V}$, 4-V Step, $G = 1$	25°C		200		ns
		0.01%, $V_S = 5\text{ V}$, 4-V Step, $G = 1$	25°C		300		
	Overload recovery time	$V_S = 5\text{ V}$, $V_{IN} \times \text{Gain} > V_S$	25°C		< 0.1		μs
THD+N	Total harmonic distortion + noise ⁽³⁾	$V_S = 5\text{ V}$, $R_L = 600\ \Omega$, $V_O = 4\text{ VPP}$, $G = 1$, $f = 1\text{ kHz}$	25°C		0.0004		%
OUTPUT							
	Voltage output swing from rail	$R_L = 10\text{ k}\Omega$, $V_S = 5.5\text{ V}$	Full range		10	20	mV
I_{SC}	Short-circuit current		25°C		± 65		mA
C_L	Capacitive load drive		25°C		See Typical Characteristics		
	Open-loop output impedance	$f = 1\text{ MHz}$, $I_O = 0$	25°C		30		Ω
POWER SUPPLY							
V_S	Specified voltage		25°C	2.2		5.5	V

(1) Full range $T_A = -40^\circ\text{C}$ to 125°C

(2) For OPA2365-Q1 only

(3) Third-order filter, bandwidth 80 kHz at -3 dB.

Electrical Characteristics (continued)
 $V_S = 2.2\text{ V to }5.5\text{ V}$, $R_L = 10\text{ k}\Omega$ connected to $V_S/2$, $V_{CM} = V_S/2$, and $V_{OUT} = V_S/2$ (unless otherwise noted)

PARAMETER		TEST CONDITIONS	$T_A^{(1)}$	MIN	TYP	MAX	UNIT
I_Q	Quiescent current per amplifier	$I_O = 0$	25°C		4.6	5	mA
			Full range			5.3	
TEMPERATURE RANGE							
	Specified		25°C	-40		125	°C
θ_{JA}	Thermal resistance	SOT23-5	25°C				°C/W
		SO-8	25°C		200		

7.6 Typical Characteristics

$T_A = 25^\circ\text{C}$, $V_S = 5\text{ V}$, $C_L = 0\text{ pF}$ (unless otherwise noted)

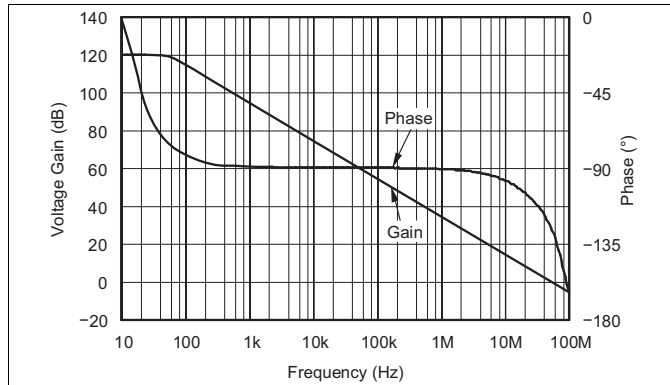

Figure 1. Open-Loop Gain and Phase vs Frequency

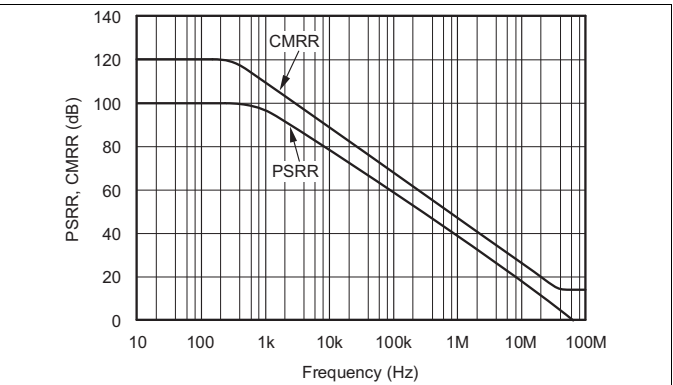

Figure 2. Power Supply and Common Mode Rejection Ratio vs Frequency

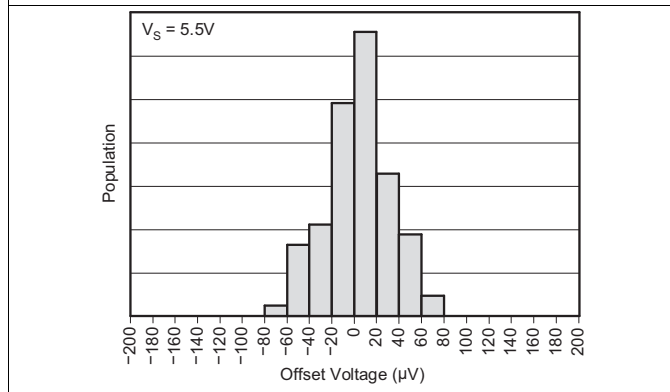

Figure 3. Offset Voltage Production Distribution

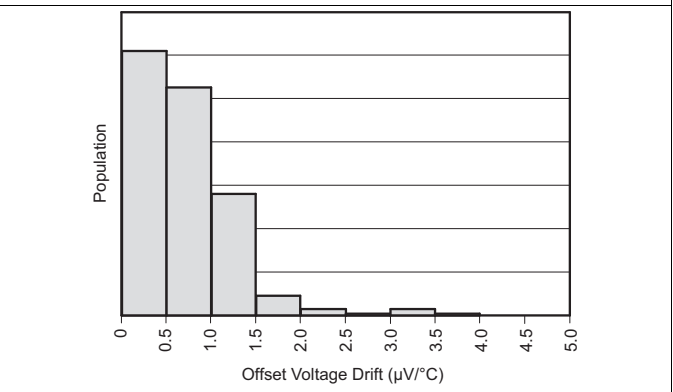

Figure 4. Offset Voltage Drift Production Distribution

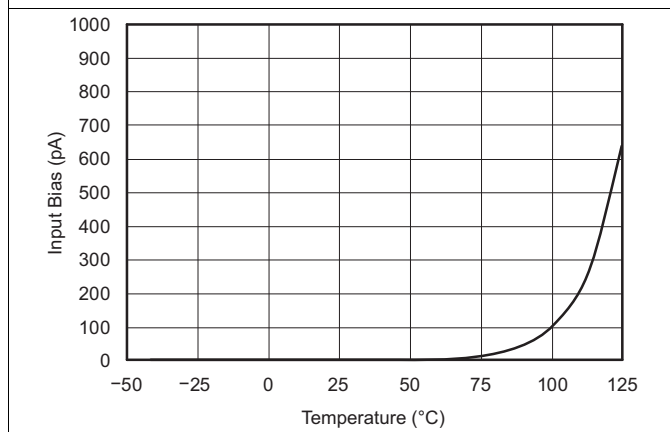

Figure 5. Input Bias Current vs Temperature

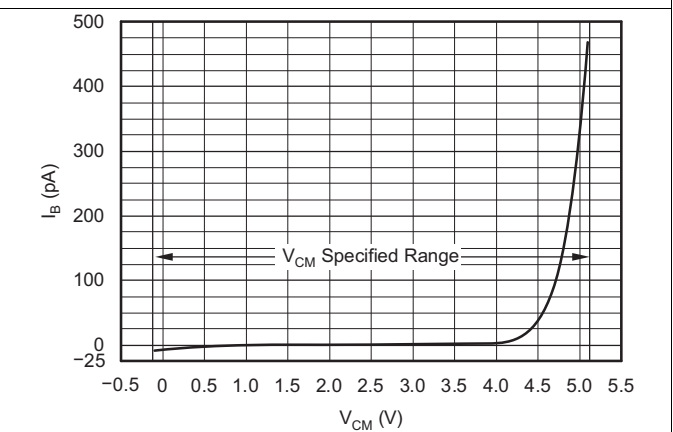

Figure 6. Input Bias Current vs Common Mode Voltage

Typical Characteristics (continued)

$T_A = 25^\circ\text{C}$, $V_S = 5\text{ V}$, $C_L = 0\text{ pF}$ (unless otherwise noted)

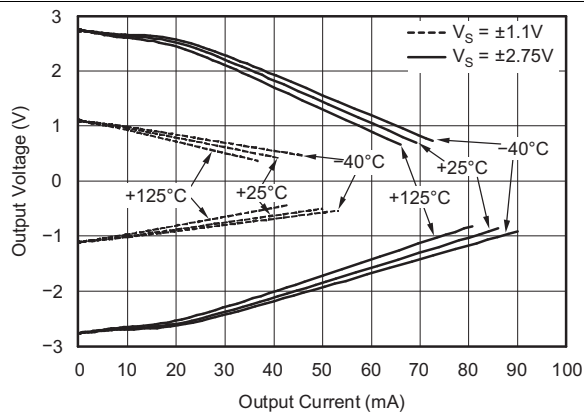

Figure 7. OPA365-Q1 Output Voltage vs Output Current

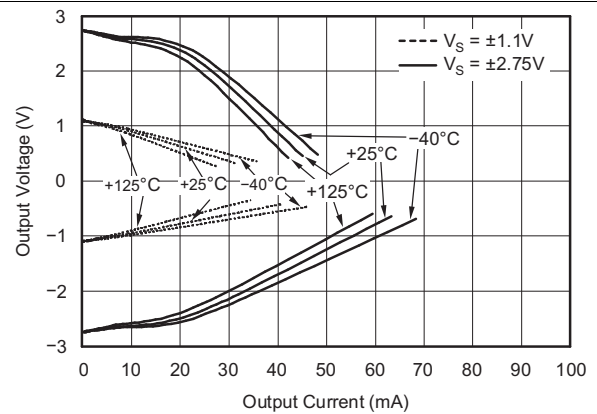

Figure 8. OPA2365-Q1 Output Voltage Swing vs Output Current

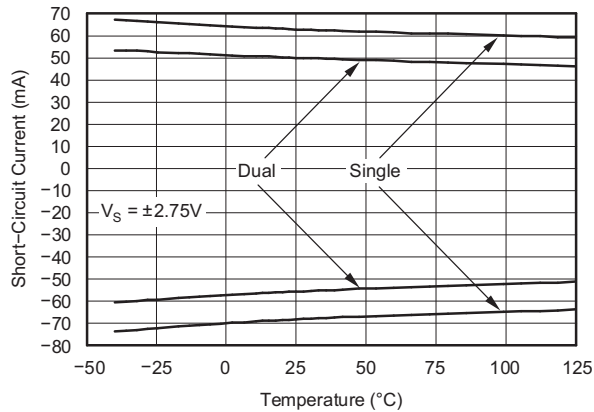

Figure 9. Short-Circuit Current vs Temperature

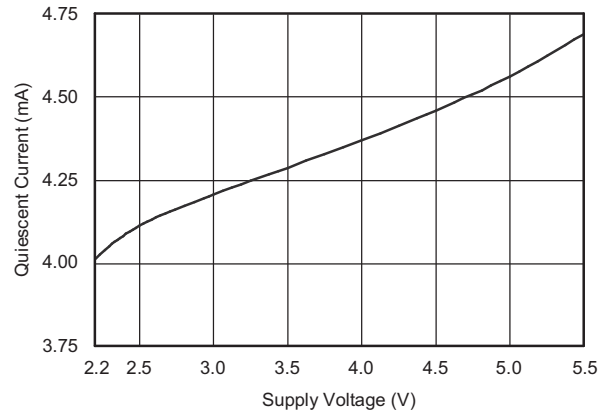

Figure 10. Quiescent Current vs Supply Voltage

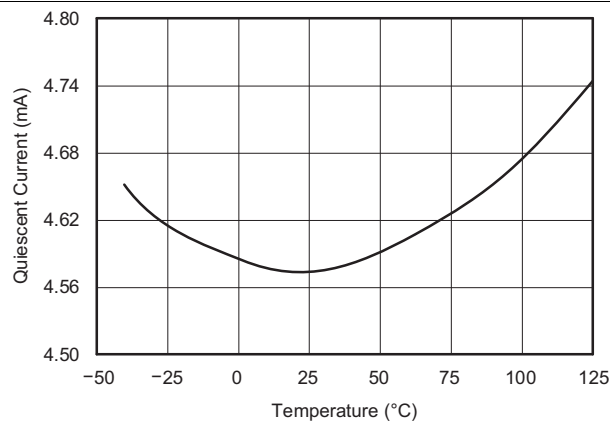

Figure 11. Quiescent Current vs Temperature

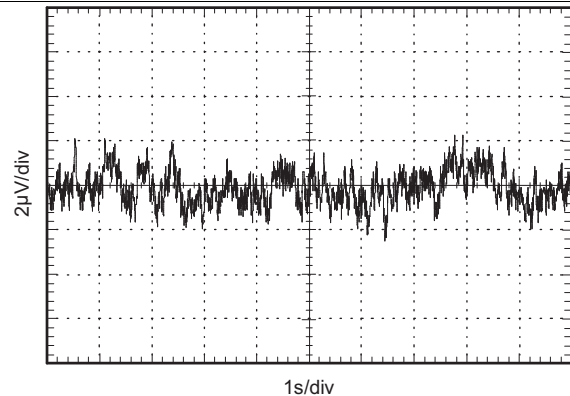

Figure 12. 0.1-Hz to 10-Hz Input Voltage Noise

Typical Characteristics (continued)

$T_A = 25^\circ\text{C}$, $V_S = 5\text{ V}$, $C_L = 0\text{ pF}$ (unless otherwise noted)

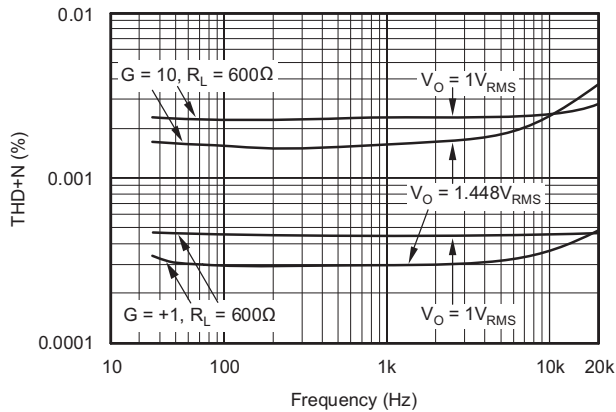

Figure 13. Total Harmonic Distortion + Noise vs Frequency

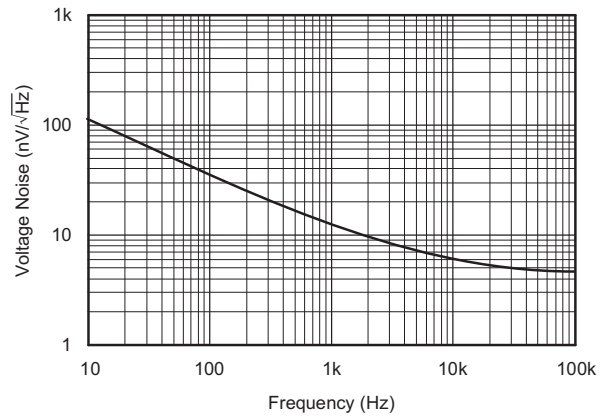

Figure 14. Input Voltage Noise Spectral Density

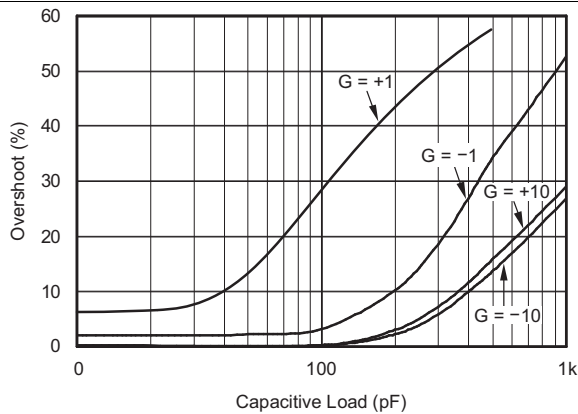

Figure 15. Overshoot vs Capacitive Load

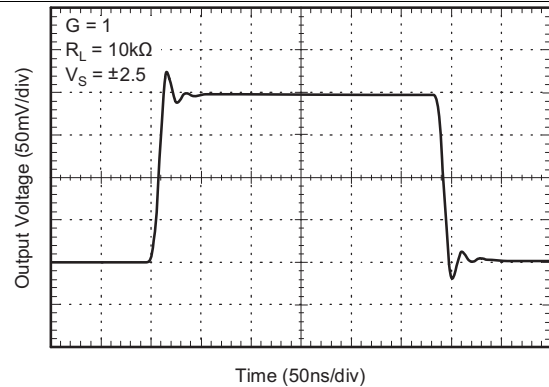

Figure 16. Small-Signal Step Response

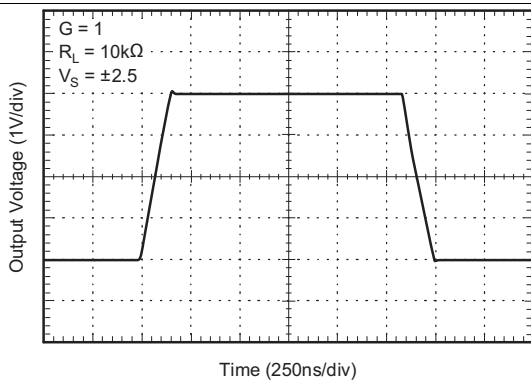

Figure 17. Large-Signal Step Response

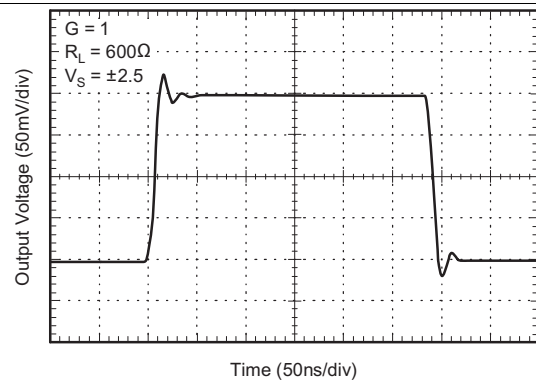

Figure 18. Small-Signal Step Response

Typical Characteristics (continued)

$T_A = 25^\circ\text{C}$, $V_S = 5\text{ V}$, $C_L = 0\text{ pF}$ (unless otherwise noted)

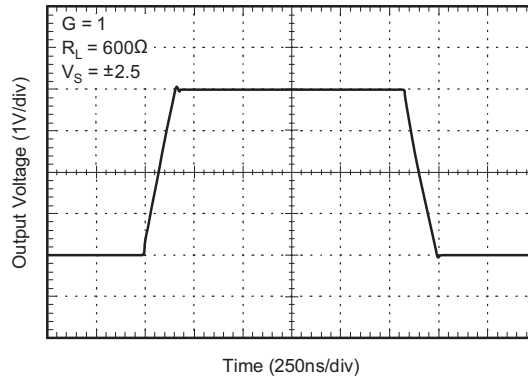

Figure 19. Large-Signal Step Response

8 Detailed Description

8.1 Overview

The OPAx365-Q1 zero-crossover family of rail-to-rail, high-performance, CMOS operational amplifiers are optimized for very low voltage, single-supply applications. Their rail-to-rail input and output, low-noise (4.5 nV/ $\sqrt{\text{Hz}}$), and high-speed operation (50-MHz gain bandwidth) make these devices ideal for driving sampling analog-to-digital converters (ADCs). Applications include audio, signal conditioning, and sensor amplification. The high-gain bandwidth of 50 MHz makes this family suited for amplifying low signal levels and high frequency such as radar signal processing .

8.2 Functional Block Diagram

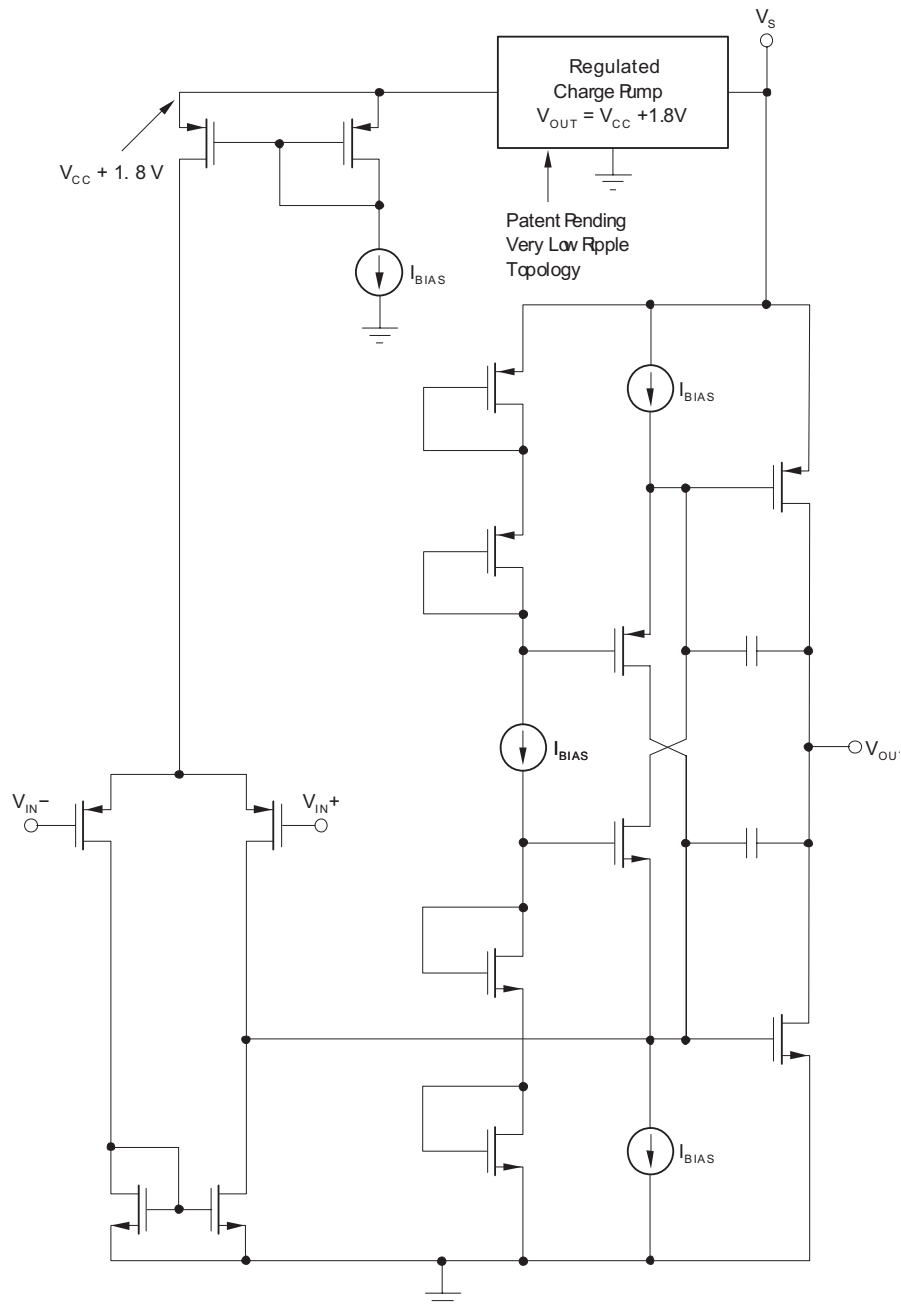

8.3 Feature Description

8.3.1 Operating Characteristics

The OPA365-Q1 amplifier parameters are fully specified from 2.2 V to 5.5 V. Many of the specifications apply from -40°C to 125°C . Parameters that can exhibit significant variance with regard to operating voltage or temperature are presented in *Typical Characteristics*.

8.3.2 Basic Amplifier Configurations

As with other single-supply operational amplifiers, the OPA365-Q1 may be operated with either a single supply or dual supplies (see Figure 20). A typical dual-supply connection is shown in Figure 20, which is accompanied by a single-supply connection. The OPA365-Q1 device is configured as a basic inverting amplifier with a gain of -10 V/V. The dual-supply connection has an output voltage centered on zero, while the single-supply connection has an output centered on the common-mode voltage V_{CM} . For the circuit shown, this voltage is 1.5 V, but may be any value within the common-mode input voltage range. The OPA365-Q1 V_{CM} range extends 100 mV beyond the power-supply rails.

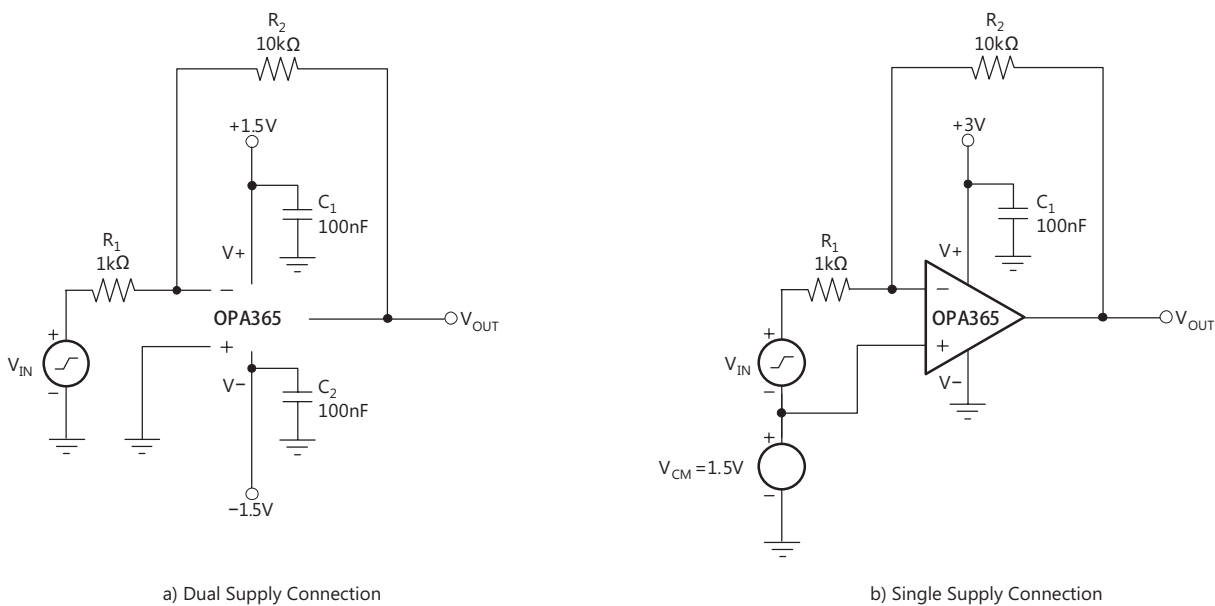

Figure 20. Basic Circuit Connections

Figure 21 shows a single-supply, electret microphone application where V_{CM} is provided by a resistive divider. The divider also provides the bias voltage for the electret element.

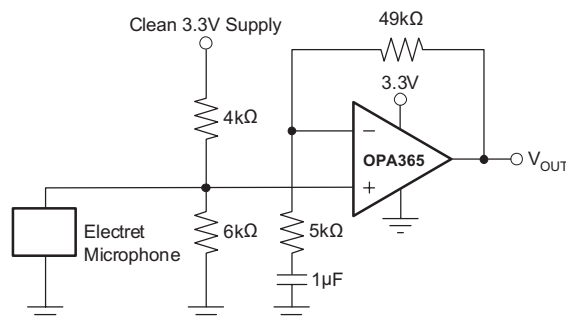

Figure 21. Microphone Preamplifier

Feature Description (continued)

8.3.3 Input and ESD Protection

The OPA365-Q1 device incorporates internal electrostatic discharge (ESD) protection circuits on all pins. In the case of input and output pins, this protection primarily consists of current steering diodes connected between the input and power-supply pins. These ESD protection diodes also provide in-circuit, input overdrive protection, provided that the current is limited to 10 mA as stated in the [Absolute Maximum Ratings](#). Figure 22 shows how a series input resistor may be added to the driven input to limit the input current. The added resistor contributes thermal noise at the amplifier input and its value should be kept to the minimum in noise-sensitive applications.

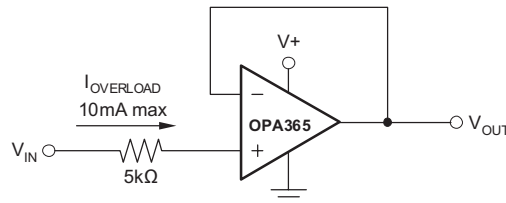

Figure 22. Input Current Protection

8.3.4 Rail-to-Rail Input

The OPA365-Q1 product family features true rail-to-rail input operation, with supply voltages as low as ± 1.1 V (2.2 V). A unique zero-crossover input topology eliminates the input offset transition region typical of many rail-to-rail, complementary stage operational amplifiers. This topology also allows the OPA365-Q1 device to provide superior common-mode performance over the entire input range, which extends 100 mV beyond both power-supply rails, as shown in Figure 23. When driving ADCs, the highly linear VCM range of the OPA365-Q1 device assures that the operational amplifier/ADC system linearity performance is not compromised.

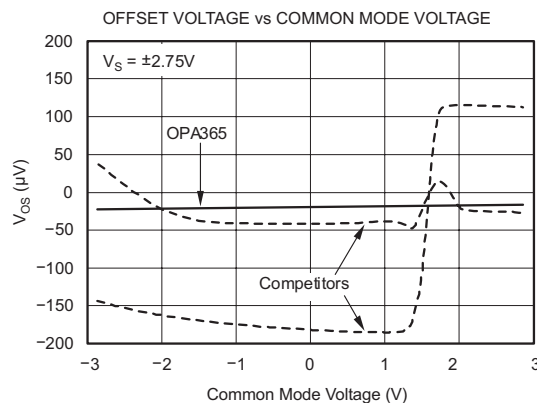

Figure 23. OPA365-Q1 Has Linear Offset Over the Entire Common-Mode Range

8.4 Device Functional Modes

The OPAx365-Q1 family of devices is powered on when the supply is connected. The device can be operated as a single-supply operational amplifier or a dual-supply amplifier depending on the application.

9 Application and Implementation

NOTE

Information in the following applications sections is not part of the TI component specification, and TI does not warrant its accuracy or completeness. TI's customers are responsible for determining suitability of components for their purposes. Customers should validate and test their design implementation to confirm system functionality.

9.1 Application Information

9.1.1 Capacitive Loads

The OPA365-Q1 device may be used in applications where driving a capacitive load is required. As with all operational amplifiers, there may be specific instances where the OPA365-Q1 device can become unstable, leading to oscillation. The particular operational amplifier circuit configuration, layout, gain and output loading are some of the factors to consider when establishing whether an amplifier will be stable in operation. An operational amplifier in the unity-gain (1 V/V) buffer configuration and driving a capacitive load exhibits a greater tendency to be unstable than an amplifier operated at a higher noise gain. The capacitive load, in conjunction with the operational amplifier output resistance, creates a pole within the feedback loop that degrades the phase margin. The degradation of the phase margin increases as the capacitive loading increases.

When operating in the unity-gain configuration, the OPA365-Q1 device remains stable with a pure capacitive load up to approximately 1 nF. The equivalent series resistance (ESR) of some very large capacitors ($C_L > 1 \mu\text{F}$) is sufficient to alter the phase characteristics in the feedback loop such that the amplifier remains stable. Increasing the amplifier closed-loop gain allows the amplifier to drive increasingly larger capacitance. This increased capability is evident when observing the overshoot response of the amplifier at higher voltage gains. See [Figure 15](#).

One technique for increasing the capacitive load drive capability of the amplifier operating in unity gain is to insert a small resistor, typically 10 Ω to 20 Ω , in series with the output; see [Figure 24](#). This resistor significantly reduces the overshoot and ringing associated with large capacitive loads. A possible problem with this technique is that a voltage divider is created with the added series resistor and any resistor connected in parallel with the capacitive load. The voltage divider introduces a gain error at the output that reduces the output swing. The error contributed by the voltage divider may be insignificant. For instance, with a load resistance, $R_L = 10 \text{ k}\Omega$, and $R_S = 20 \Omega$, the gain error is only about 0.2%. However, when R_L is decreased to 600 Ω , which the OPA365-Q1 device is able to drive, the error increases to 7.5%.

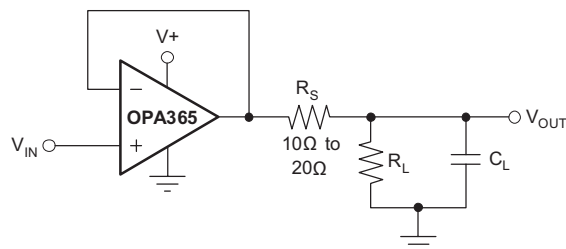

Figure 24. Improving Capacitive Load Drive

9.1.2 Achieving an Output Level of Zero Volts (0 V)

Certain single-supply applications require the operational amplifier output to swing from 0 V to a positive full-scale voltage and have high accuracy. An example is an operational amplifier employed to drive a single-supply ADC having an input range from 0 V to 5 V. Rail-to-rail output amplifiers with very light output loading may achieve an output level within millivolts of 0 V (or $+V_S$ at the high end), but not 0 V. Furthermore, the deviation from 0 V only becomes greater as the load current required increases. This increased deviation is a result of limitations of the CMOS output stage.

When a pull-down resistor is connected from the amplifier output to a negative voltage source, the OPA365-Q1 can achieve an output level of 0 V, and even a few millivolts below 0 V. Below this limit, nonlinearity and limiting conditions become evident. [Figure 25](#) illustrates a circuit using this technique.

Application Information (continued)

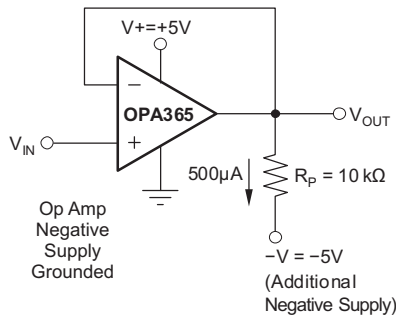

Figure 25. Swing-to-Ground

A pull-down current of approximately 500 μA is required when OPA365-Q1 is connected as a unity-gain buffer. A practical termination voltage (V_{NEG}) is -5 V , but other convenient negative voltages also may be used. The pull-down resistor R_L is calculated from $R_L = [(V_O - V_{\text{NEG}})/(500\ \mu\text{A})]$. Using a minimum output voltage (V_O) of 0 V , $R_L = [0\text{ V} - (-5\text{ V})]/(500\ \mu\text{A}) = 10\text{ k}\Omega$. Keep in mind that lower termination voltages result in smaller pull-down resistors that load the output during positive output voltage excursions.

This technique does not work with all operational amplifier, and should only be applied to operational amplifiers, such as the OPA365-Q1, that have been specifically designed to operate in this manner. Also, operating the OPA365-Q1 output at 0 V changes the output stage operating conditions, resulting in somewhat lower open-loop gain and bandwidth. Keep these precautions in mind when driving a capacitive load because these conditions can affect circuit transient response and stability.

9.1.3 Active Filtering

The OPA365-Q1 device is well-suited for active filter applications requiring a wide bandwidth, fast slew rate, low-noise, and single-supply operational amplifier. [Figure 26](#) shows a 500 kHz, 2nd-order, low-pass filter utilizing the multiple-feedback (MFB) topology. The components have been selected to provide a maximally-flat Butterworth response. Beyond the cutoff frequency, roll-off is -40 dB/dec . The Butterworth response is ideal for applications requiring predictable gain characteristics such as the anti-aliasing filter used ahead of an ADC.

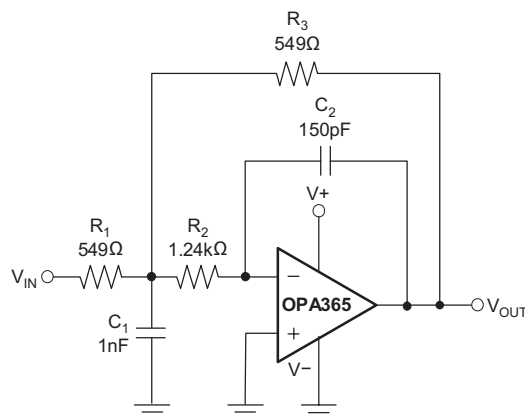

Figure 26. Second-Order Butterworth 500-kHz Low-Pass Filter

One point to observe when considering the MFB filter is that the output is inverted, relative to the input. If this inversion is not required, or not desired, a noninverting output can be achieved through one of these options:

1. adding an inverting amplifier;
2. adding an additional 2nd-order MFB stage;
3. using a noninverting filter topology such as the Sallen-Key (shown in [Figure 27](#)).

Application Information (continued)

MFB and Sallen-Key, low-pass and high-pass filter synthesis is quickly accomplished using TI's FilterPro program. This software is available as a free download at www.ti.com.

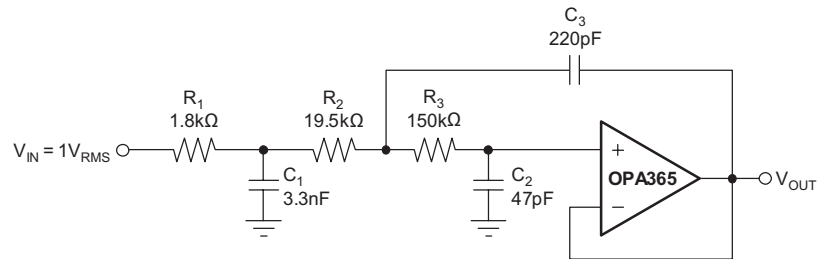

Figure 27. Configured as a 3-Pole, 20 kHz, Sallen-Key Filter

9.1.4 Driving an ADS7822-Q1 Analog-to-Digital Converter

The OPAx365-Q1 operational amplifiers are optimized for driving medium to high speed sampling A/D converters. The OPAx365-Q1 op amps buffer the A/D's input capacitance and resulting charge injection while providing signal gain. [Figure 28](#) shows the OPAx365-Q1 in a basic noninverting configuration driving the ADS7822-Q1. The ADS7822-Q1 is a 12-bit, micro-power sampling converter in the MSOP-8 package. When used with the low-power, miniature packages of the OPAx365-Q1, the combination is ideal for space-limited, low power applications. In this configuration, an RC network at the A/D's input can be used to filter charge injection.

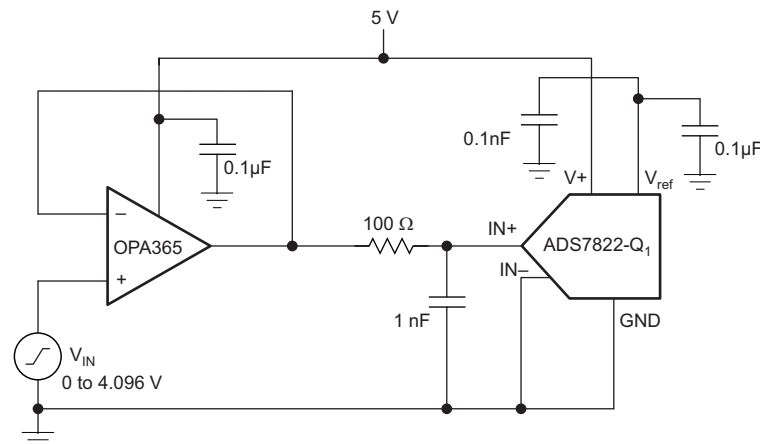

Figure 28. Driving the ADS7822-Q1

9.1.5 Driving ADS1115-Q1 Analog-to-Digital Converter

Some applications such as multi-channels mid range radar need selection between channels. OPA2365-Q1 combined with ADS1115-Q1 fit very well for 2 channels radar selection. The circuit in [Figure 29](#) shows the same band pass filter but the components can be modified for different desired band pass.

The ADS1115-Q1 inputs are set as differential. the inputs accept up to the ± 2 V. The OPA2365-Q1 flat gain is 100 so the input signal peak is 20 mV.

Application Information (continued)

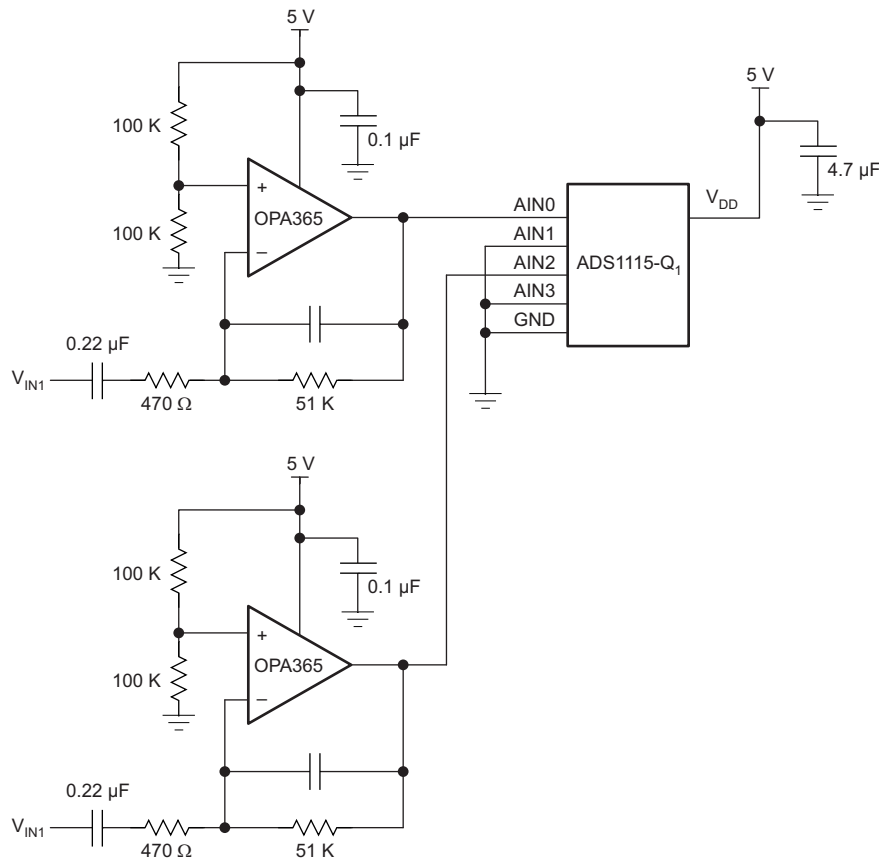

Figure 29. Driving the ADS1115-Q1

9.2 Typical Application

9.2.1 Fast Settling Peak Detector

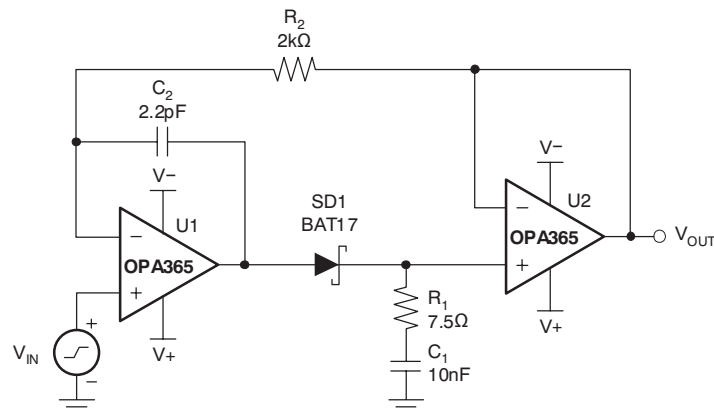

Figure 30. Fast Settling Peak Detector Schematic

Some applications require peak signal measurement. High unity gain bandwidth, wide supply voltage range, rail-to-rail input and output, and very low input bias current make the OPA2365-Q1 device very suitable for a peak detector circuit.

Typical Application (continued)

9.2.1.1 Design Requirements

Use the following design parameters for this application:

- Supply voltage: 2.2 V to 5 V
- Input signal: 0 V to 4.5 V
- Input signal frequency: 0 MHz to 1 MHz

9.2.1.2 Detailed Design Procedure

The circuit in Figure 30 detects the peak of an input signal and generates a DC output equal to the peak level $V_{OUT} = V_{INpeak}$. The capacitor C1 is charged through the SD1 diode and limiting resistor R1. The only discharging path for C1 is the OPA2365-Q1 very high input impedance. This allows the peak detection of low frequency and low-duty cycle signal.

9.2.1.3 Application Curves

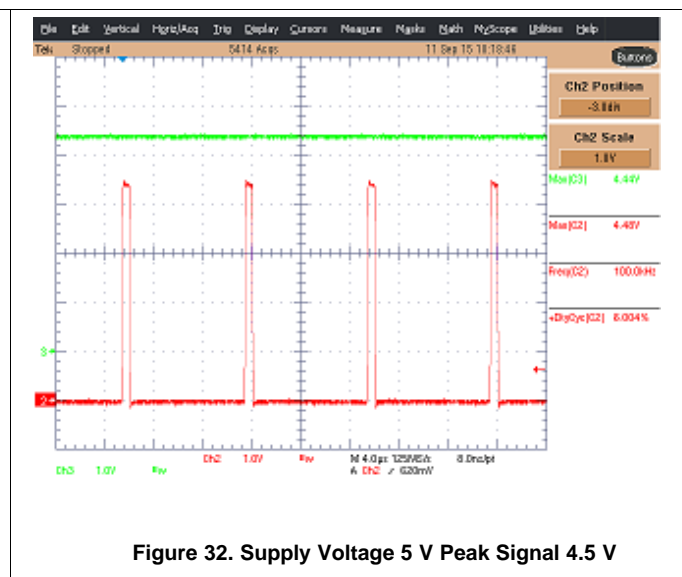
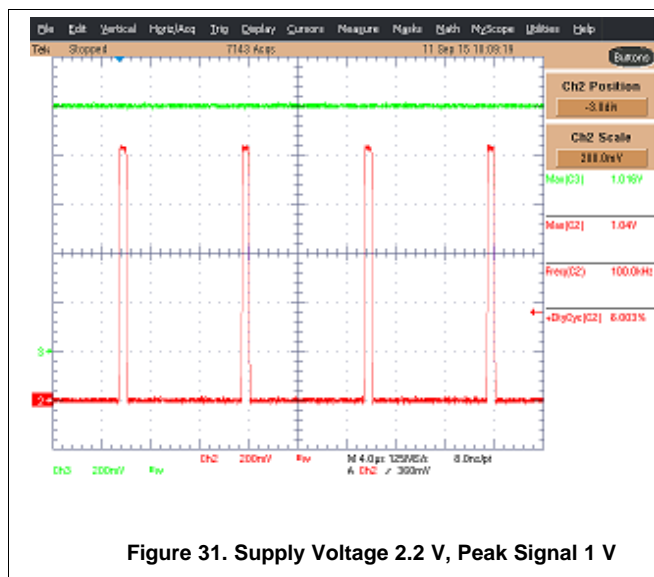

9.2.2 Bandpass Filter 1.5 kHz to 160 kHz and 40-dB Flat Gain

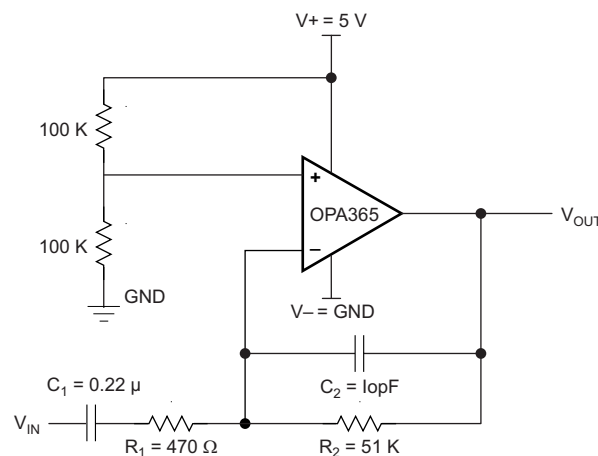

Figure 33. Bandpass Filter 1.5 kHz to 160 kHz and 40-dB Flat Gain Schematic

Typical Application (continued)

9.2.2.1 Design Requirements

Use the following design parameters for this application:

- Supply voltage: 2.2 V to 5 V
- Input signal: 0 V to 25 mV
- Input signal frequency: 0 MHz to 1 MHz

9.2.2.2 Detailed Design Procedure

Some applications need bandpass filter—that is, radar or audio signal preprocessing. The cross over frequencies and flat gain can be adjusted by changing the resistors and capacitors value according to applications.

The circuit is designed for 5-V supply and 20-mV input signal. With a flat gain of 100 dB or 40 dB, the peak output signal is 2 V. The reference signal is at half way of 5 V, which is 2.5 V.

$$\text{The transfer function or gain} = \frac{V_{\text{out}}}{V_{\text{in}}} = -\frac{R_2 C_1 S}{(1 + R_1 C_1 S)(1 + R_2 C_2 S)} \quad (1)$$

$$\text{A zero at} = \frac{1}{2\pi R_2 C_1} = 14.2 \text{ Hz} \quad (2)$$

$$\text{A pole at} = \frac{1}{2\pi R_1 C_1} = 1.54 \text{ KHz} \quad (3)$$

$$\text{A pole at} = \frac{1}{2\pi R_2 C_2} = 156 \text{ KHz} \quad (4)$$

Flat Gain of 100 or 40 dB between 1.54 kHz and 156 kHz (5)

20 db/decade below 1.54 KHz (6)

–20 dB/decade above 156 kHz (7)

Bandpass between 1.54 kHz and 156 kHz (8)

9.2.2.3 Application Curves

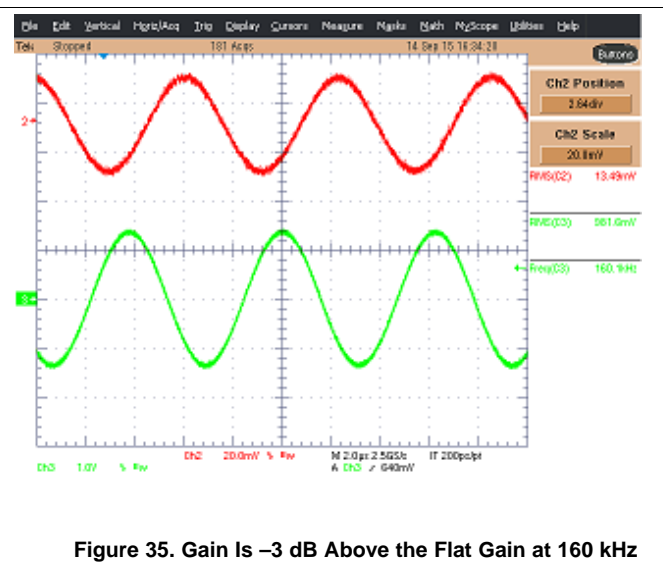
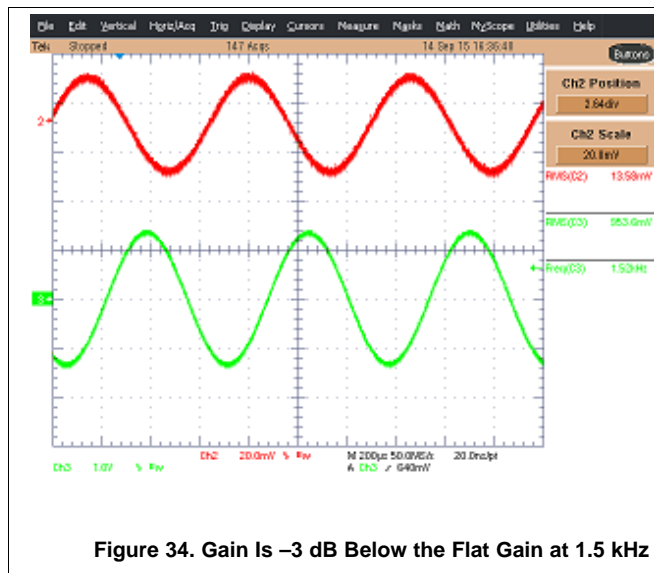

10 Power Supply Recommendations

The OPAx365-Q1 family of devices is specified for operation from 2.2 V to 5.5 V (± 1.1 V to ± 2.75 V); many specifications apply from -40°C to 125°C . The [Typical Characteristics](#) presents parameters that can exhibit significant variance with regard to operating voltage or temperature.

CAUTION

Supply voltages larger than 7 V can permanently damage the device (see [Absolute Maximum Ratings](#)).

Place 0.1- μF bypass capacitors close to the power-supply pins to reduce errors coupling in from noisy or high impedance power supplies. For more detailed information on bypass capacitor placement, see [Layout Guidelines](#).

11 Layout

11.1 Layout Guidelines

The OPA365-Q1 is a wideband amplifier. To realize the full operational performance of the device, good high-frequency printed-circuit-board (PCB) layout practices are required. Low-loss 0.1- μF bypass capacitors must be connected between each supply pin and ground as close to the device as possible. The bypass capacitor traces should be designed for minimum inductance.

11.2 Layout Example

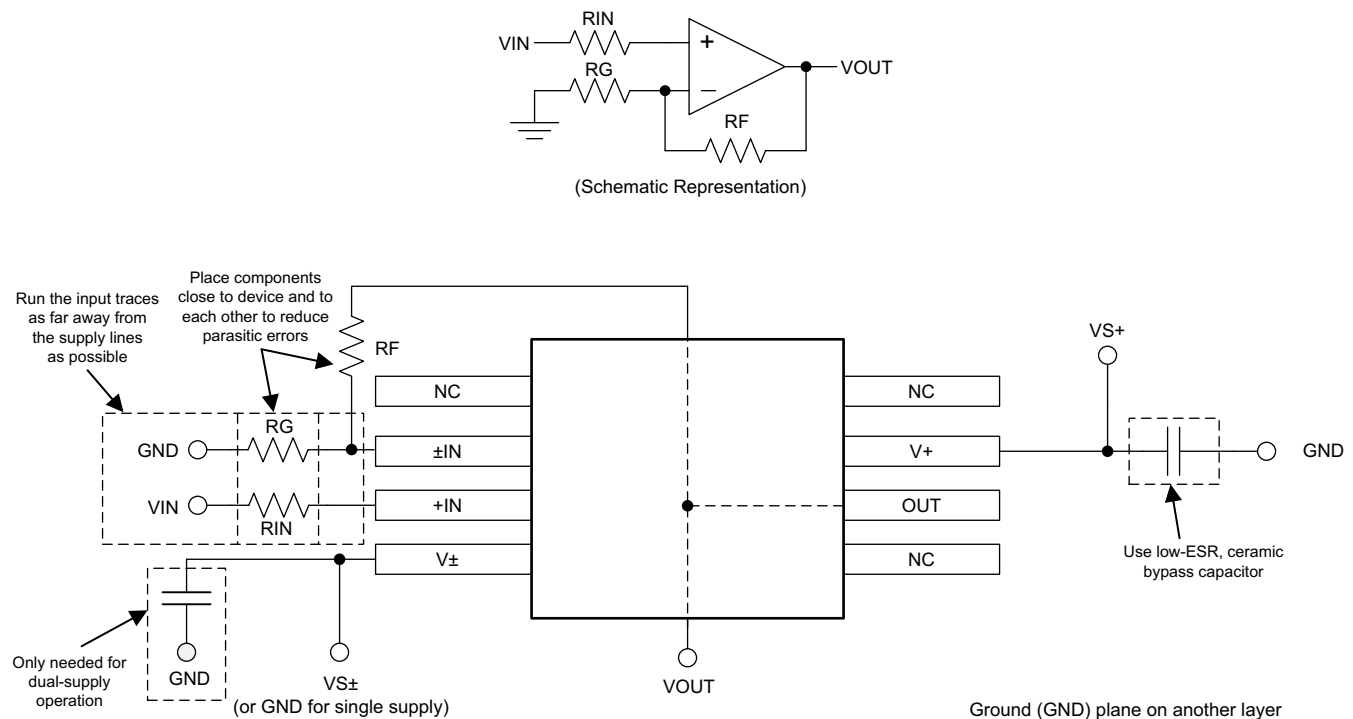

Figure 36. Layout Recommendation

12 Device and Documentation Support

12.1 Documentation Support

12.1.1 Related Documentation

For related documentation see the data sheet, *ADS1258 16-Channel, 24-Bit Analog-to-Digital Converter (SBAS297)*.

12.2 Related Links

The table below lists quick access links. Categories include technical documents, support and community resources, tools and software, and quick access to sample or buy.

Table 1. Related Links

PARTS	PRODUCT FOLDER	SAMPLE & BUY	TECHNICAL DOCUMENTS	TOOLS & SOFTWARE	SUPPORT & COMMUNITY
OPA365-Q1	Click here	Click here	Click here	Click here	Click here
OPA2365-Q1	Click here	Click here	Click here	Click here	Click here

12.3 Community Resources

The following links connect to TI community resources. Linked contents are provided "AS IS" by the respective contributors. They do not constitute TI specifications and do not necessarily reflect TI's views; see TI's [Terms of Use](#).

TI E2E™ Online Community *TI's Engineer-to-Engineer (E2E) Community*. Created to foster collaboration among engineers. At e2e.ti.com, you can ask questions, share knowledge, explore ideas and help solve problems with fellow engineers.

Design Support *TI's Design Support* Quickly find helpful E2E forums along with design support tools and contact information for technical support.

12.4 Trademarks

E2E is a trademark of Texas Instruments.
All other trademarks are the property of their respective owners.

12.5 Electrostatic Discharge Caution



These devices have limited built-in ESD protection. The leads should be shorted together or the device placed in conductive foam during storage or handling to prevent electrostatic damage to the MOS gates.

12.6 Glossary

SLYZ022 — *TI Glossary*.

This glossary lists and explains terms, acronyms, and definitions.

13 Mechanical, Packaging, and Orderable Information

The following pages include mechanical, packaging, and orderable information. This information is the most current data available for the designated devices. This data is subject to change without notice and revision of this document. For browser-based versions of this data sheet, refer to the left-hand navigation.

PACKAGING INFORMATION

Orderable Device	Status (1)	Package Type	Package Drawing	Pins	Package Qty	Eco Plan (2)	Lead/Ball Finish (6)	MSL Peak Temp (3)	Op Temp (°C)	Device Marking (4/5)	Samples
OPA2365AQDRQ1	ACTIVE	SOIC	D	8	2500	Green (RoHS & no Sb/Br)	CU NIPDAU	Level-3-260C-168 HR	-40 to 125	O2365Q	Samples
OPA365AQDBVRQ1	ACTIVE	SOT-23	DBV	5	3000	Green (RoHS & no Sb/Br)	CU NIPDAU	Level-1-260C-UNLIM	-40 to 125	OTNQ	Samples

(1) The marketing status values are defined as follows:

ACTIVE: Product device recommended for new designs.

LIFEBUY: TI has announced that the device will be discontinued, and a lifetime-buy period is in effect.

NRND: Not recommended for new designs. Device is in production to support existing customers, but TI does not recommend using this part in a new design.

PREVIEW: Device has been announced but is not in production. Samples may or may not be available.

OBSELETE: TI has discontinued the production of the device.

(2) Eco Plan - The planned eco-friendly classification: Pb-Free (RoHS), Pb-Free (RoHS Exempt), or Green (RoHS & no Sb/Br) - please check <http://www.ti.com/productcontent> for the latest availability information and additional product content details.

TBD: The Pb-Free/Green conversion plan has not been defined.

Pb-Free (RoHS): TI's terms "Lead-Free" or "Pb-Free" mean semiconductor products that are compatible with the current RoHS requirements for all 6 substances, including the requirement that lead not exceed 0.1% by weight in homogeneous materials. Where designed to be soldered at high temperatures, TI Pb-Free products are suitable for use in specified lead-free processes.

Pb-Free (RoHS Exempt): This component has a RoHS exemption for either 1) lead-based flip-chip solder bumps used between the die and package, or 2) lead-based die adhesive used between the die and leadframe. The component is otherwise considered Pb-Free (RoHS compatible) as defined above.

Green (RoHS & no Sb/Br): TI defines "Green" to mean Pb-Free (RoHS compatible), and free of Bromine (Br) and Antimony (Sb) based flame retardants (Br or Sb do not exceed 0.1% by weight in homogeneous material)

(3) MSL, Peak Temp. - The Moisture Sensitivity Level rating according to the JEDEC industry standard classifications, and peak solder temperature.

(4) There may be additional marking, which relates to the logo, the lot trace code information, or the environmental category on the device.

(5) Multiple Device Markings will be inside parentheses. Only one Device Marking contained in parentheses and separated by a "~" will appear on a device. If a line is indented then it is a continuation of the previous line and the two combined represent the entire Device Marking for that device.

(6) Lead/Ball Finish - Orderable Devices may have multiple material finish options. Finish options are separated by a vertical ruled line. Lead/Ball Finish values may wrap to two lines if the finish value exceeds the maximum column width.

Important Information and Disclaimer:The information provided on this page represents TI's knowledge and belief as of the date that it is provided. TI bases its knowledge and belief on information provided by third parties, and makes no representation or warranty as to the accuracy of such information. Efforts are underway to better integrate information from third parties. TI has taken and continues to take reasonable steps to provide representative and accurate information but may not have conducted destructive testing or chemical analysis on incoming materials and chemicals. TI and TI suppliers consider certain information to be proprietary, and thus CAS numbers and other limited information may not be available for release.

In no event shall TI's liability arising out of such information exceed the total purchase price of the TI part(s) at issue in this document sold by TI to Customer on an annual basis.

OTHER QUALIFIED VERSIONS OF OPA2365-Q1, OPA365-Q1 :

- Catalog: [OPA2365](#), [OPA365](#)
- Enhanced Product: [OPA365-EP](#)

NOTE: Qualified Version Definitions:

- Catalog - TI's standard catalog product
- Enhanced Product - Supports Defense, Aerospace and Medical Applications

TAPE AND REEL INFORMATION



QUADRANT ASSIGNMENTS FOR PIN 1 ORIENTATION IN TAPE



*All dimensions are nominal

Device	Package Type	Package Drawing	Pins	SPQ	Reel Diameter (mm)	Reel Width W1 (mm)	A0 (mm)	B0 (mm)	K0 (mm)	P1 (mm)	W (mm)	Pin1 Quadrant
OPA2365AQDRQ1	SOIC	D	8	2500	330.0	12.4	6.4	5.2	2.1	8.0	12.0	Q1
OPA365AQDBVRQ1	SOT-23	DBV	5	3000	179.0	8.4	3.2	3.2	1.4	4.0	8.0	Q3

TAPE AND REEL BOX DIMENSIONS



*All dimensions are nominal

Device	Package Type	Package Drawing	Pins	SPQ	Length (mm)	Width (mm)	Height (mm)
OPA2365AQDRQ1	SOIC	D	8	2500	367.0	367.0	35.0
OPA365AQDBVRQ1	SOT-23	DBV	5	3000	203.0	203.0	35.0



D0008A

PACKAGE OUTLINE

SOIC - 1.75 mm max height

SMALL OUTLINE INTEGRATED CIRCUIT



4214825/C 02/2019

NOTES:

- Linear dimensions are in inches [millimeters]. Dimensions in parenthesis are for reference only. Controlling dimensions are in inches. Dimensioning and tolerancing per ASME Y14.5M.
- This drawing is subject to change without notice.
- This dimension does not include mold flash, protrusions, or gate burrs. Mold flash, protrusions, or gate burrs shall not exceed $.006$ [0.15] per side.
- This dimension does not include interlead flash.
- Reference JEDEC registration MS-012, variation AA.

EXAMPLE BOARD LAYOUT

D0008A

SOIC - 1.75 mm max height

SMALL OUTLINE INTEGRATED CIRCUIT



LAND PATTERN EXAMPLE
EXPOSED METAL SHOWN
SCALE:8X



SOLDER MASK DETAILS

4214825/C 02/2019

NOTES: (continued)

- 6. Publication IPC-7351 may have alternate designs.
- 7. Solder mask tolerances between and around signal pads can vary based on board fabrication site.

EXAMPLE STENCIL DESIGN

D0008A

SOIC - 1.75 mm max height

SMALL OUTLINE INTEGRATED CIRCUIT



SOLDER PASTE EXAMPLE
BASED ON .005 INCH [0.125 MM] THICK STENCIL
SCALE:8X

4214825/C 02/2019

NOTES: (continued)

8. Laser cutting apertures with trapezoidal walls and rounded corners may offer better paste release. IPC-7525 may have alternate design recommendations.
9. Board assembly site may have different recommendations for stencil design.

EXAMPLE BOARD LAYOUT

DBV0005A

SOT-23 - 1.45 mm max height

SMALL OUTLINE TRANSISTOR



LAND PATTERN EXAMPLE
EXPOSED METAL SHOWN
SCALE:15X



SOLDER MASK DETAILS

4214839/D 11/2018

NOTES: (continued)

- 5. Publication IPC-7351 may have alternate designs.
- 6. Solder mask tolerances between and around signal pads can vary based on board fabrication site.

EXAMPLE STENCIL DESIGN

DBV0005A

SOT-23 - 1.45 mm max height

SMALL OUTLINE TRANSISTOR



SOLDER PASTE EXAMPLE
BASED ON 0.125 mm THICK STENCIL
SCALE:15X

4214839/D 11/2018

NOTES: (continued)

7. Laser cutting apertures with trapezoidal walls and rounded corners may offer better paste release. IPC-7525 may have alternate design recommendations.
8. Board assembly site may have different recommendations for stencil design.

IMPORTANT NOTICE AND DISCLAIMER

TI PROVIDES TECHNICAL AND RELIABILITY DATA (INCLUDING DATASHEETS), DESIGN RESOURCES (INCLUDING REFERENCE DESIGNS), APPLICATION OR OTHER DESIGN ADVICE, WEB TOOLS, SAFETY INFORMATION, AND OTHER RESOURCES "AS IS" AND WITH ALL FAULTS, AND DISCLAIMS ALL WARRANTIES, EXPRESS AND IMPLIED, INCLUDING WITHOUT LIMITATION ANY IMPLIED WARRANTIES OF MERCHANTABILITY, FITNESS FOR A PARTICULAR PURPOSE OR NON-INFRINGEMENT OF THIRD PARTY INTELLECTUAL PROPERTY RIGHTS.

These resources are intended for skilled developers designing with TI products. You are solely responsible for (1) selecting the appropriate TI products for your application, (2) designing, validating and testing your application, and (3) ensuring your application meets applicable standards, and any other safety, security, or other requirements. These resources are subject to change without notice. TI grants you permission to use these resources only for development of an application that uses the TI products described in the resource. Other reproduction and display of these resources is prohibited. No license is granted to any other TI intellectual property right or to any third party intellectual property right. TI disclaims responsibility for, and you will fully indemnify TI and its representatives against, any claims, damages, costs, losses, and liabilities arising out of your use of these resources.

TI's products are provided subject to TI's Terms of Sale (www.ti.com/legal/termsofsale.html) or other applicable terms available either on ti.com or provided in conjunction with such TI products. TI's provision of these resources does not expand or otherwise alter TI's applicable warranties or warranty disclaimers for TI products.

Mailing Address: Texas Instruments, Post Office Box 655303, Dallas, Texas 75265
Copyright © 2019, Texas Instruments Incorporated

Looking for pricing, stock, or lifecycle information?

Click below to explore more details on WIN SOURCE:

 [View OPA2365AQDRQ1 on WIN SOURCE](#)

 [Texas Instruments](#) Information

Optimize Your Supply Chain with WIN SOURCE Solutions

-  Global Sourcing Solution
-  Obsolete Management
-  Cost Control Management
-  Shortage Management
-  Alternative Solution
-  Excess Inventory Management