



**THE DATASHEET OF  
XRD9816BCV-F**





# XRD9814B/XRD9816B

3-Channel 14/16-Bit Linear  
CCD/CIS Sensor Signal Processors

November 2002-2

## FEATURES

- 14-Bit (XRD9814B) or 16-Bit (XRD9816B) A/D Converter
- Triple-Channel, 2.5 MSPS Color Scan Mode
- Single-Channel, 6 MSPS Monochrome Scan Mode
- Triple Correlated Double Sampler
- Triple 10-Bit Programmable Gain Amplifier
- Triple 10-Bit Offset Compensation DAC
- Fully Differential or Single-Ended Inputs
- CDS or S/H Mode
- Inverting or Non-Inverting Mode
- Internal Voltage Reference
- Serial Control: On Data Bus or Separate Pins
- Improved PGA Performance
- 14-Bit or 8-Bit (Nibble) Parallel Data Output (XRD9814B)
- 16-Bit or 8-Bit (Nibble) Parallel Data Output (XRD9816B)
- 5V Operation and 3V I/O Compatibility
- Low Power CMOS: 500mW @ 5V

## APPLICATIONS

- 48-Bit Color Scanners (XRD9816B)
- 42-Bit Color Scanners (XRD9814B)
- CCD or CIS Color Imagers
- Gray Scale Scanners
- Film Scanners

## GENERAL DESCRIPTION

The XRD9814B/9816B is a fully integrated, high-performance analog signal processor/digitizer specifically designed for use in 3-channel linear Charge Coupled Device (CCD) and Contact Image Sensitive (CIS) imaging applications.

Each channel of the XRD9814B/9816B includes a Correlated Double Sampler (CDS), Programmable Gain Amplifier (PGA) and channel offset adjustment. After gain and offset adjustment, the analog inputs are sequentially sampled and digitized by an accurate 14/16-bit A/D converter. The analog front-end can be configured for inverting/non-inverting input, CDS or sample-hold (S/H) mode, or AC/DC coupling, making the XRD9814B/9816B suitable for use in CCD, CIS and other data acquisition applications.

The CDS mode of operation supports both line and pixel-clamp modes and can be used to achieve significant reduction in system  $1/f$  noise and CCD reset clock feed-through. In S/H mode the internal DC-restore voltage clamp can be enabled or disabled to support AC-coupled or DC inputs. Sampling mode, 10-bit PGA gain (1024 linear steps), 8-bit fine offset adjustment (256 linear steps), 2-bit gross offset adjustment and input signal polarity are all programmable through a serial interface. PGA gain range is 1 to 10, and channel offset range is -300mV to 300mV for fine adjustment and additional -400mV to +200mV for gross offset adjustment. The A/D Full-Scale Range (FSR) is programmable to 2V or 3V.

## ORDERING INFORMATION

Part No.	Package Type	Temperature Range
XRD9814BCV	48-Lead TQFP	0°C to +70°C
XRD9816BCV	48-Lead TQFP	0°C to +70°C

Rev. 1.00

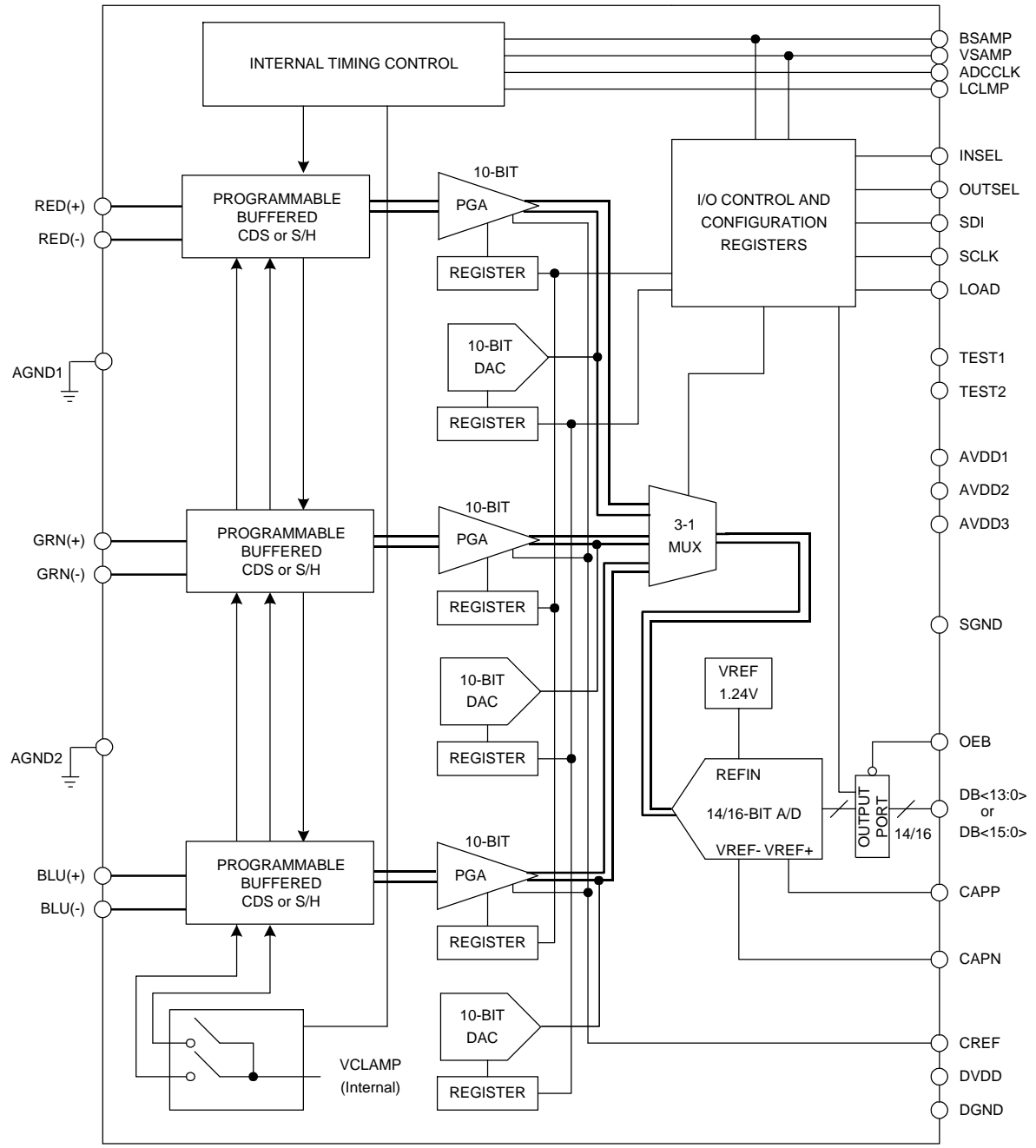
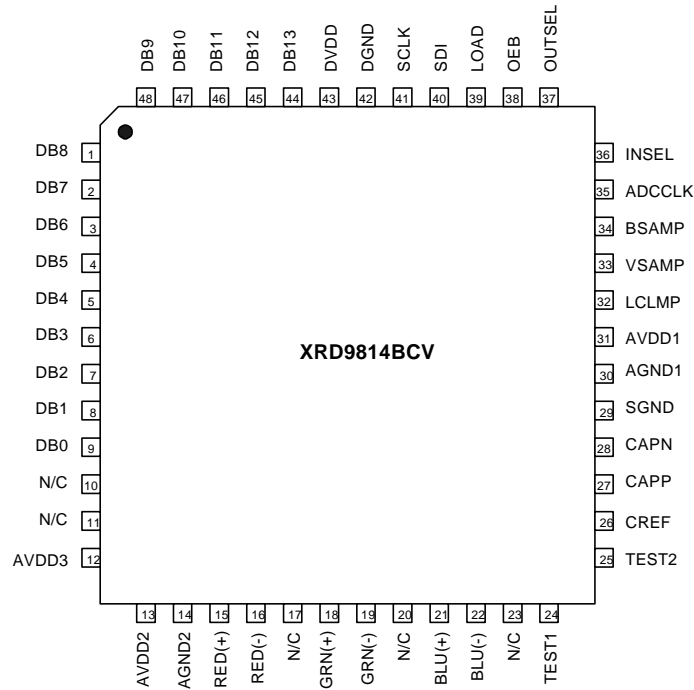

Figure 1. Block Diagram

## PIN CONFIGURATION



**Note:**

*Pins 17, 20 and 23 should be connected to AGND2 to improve noise immunity*

### PIN DESCRIPTION - XRD9814B

Pin No.	Name	Description
1	DB8	Data Output Bit 8
2	DB7	Data Output Bit 7
3	DB6	Data Output Bit 6
4	DB5	Data Output Bit 5
5	DB4	Data Output Bit 4
6	DB3	Data Output Bit 3
7	DB2	Data Output Bit 2
8	DB1	Data Output Bit 1
9	DB0	Data Output Bit 0
10	N/C	No Connect
11	N/C	No Connect
12	AV <sub>DD3</sub>	Analog Power Supply
13	AV <sub>DD2</sub>	Analog Power Supply
14	AGND2	Analog Ground (Substrate)
15	RED(+)	Red Positive Analog Input

## PIN DESCRIPTION - XRD9814B (CONT'D)

Pin No.	Name	Description
16	RED(-)	Red Negative Analog Input
17	N/C	No Connect, (Note 5)
18	GRN(+)	Green Positive Analog Input
19	GRN(-)	Green Negative Analog Input
20	N/C	No Connect, (Note 5)
21	BLU(+)	Blue Positive Analog Input
22	BLU(-)	Blue Negative Analog Input
23	N/C	No Connect, (Note 5)
24	TEST1	Internal Use Only
25	TEST2	Internal Use Only
26	CREF	Decoupling Cap for CDS Reference
27	CAPP	Decoupling Cap for Positive Reference
28	CAPN	Decoupling Cap for Negative Reference
29	SGND	Substrate Gnd
30	AGND1	Analog Ground (Substrate)
31	AV <sub>DD1</sub>	Analog Power Supply
32	LCLMP	Line Clamp Enable
33	VSAMP	Video Level Sampling Clock
34	BSAMP	Black Level Sampling Clock
35	ADCCLK	A/D Converter Clock
36	INSEL	Input Mode Select (Note 1)
37	OUTSEL	Output Mode Select (Note 2)
38	OEB	Data Output Enable
39	LOAD	Register Write Enable (Note 5)
40	SDI	Serial Data Input (Note 4)
41	SCLK	Serial Shift Clock (Note 3)
42	DGND	Ground (Output Drivers and Internal Decode Logic)
43	DV <sub>DD</sub>	Digital Power Supply (Output Drivers and Internal Decode Logic)
44	DB13	Data I/O Bit 13 (Note 4)
45	DB12	Data I/O Bit 12 (Note 3)
46	DB11	Data Output Bit 11
47	DB10	Data Output Bit 10
48	DB9	Data Output Bit 9

**Note 1:** INSEL=0 → SCLK, SDI, and LOAD pins are active for serial programming; INSEL=1 → SCLK and SDI pins are inactive, and the serial programming is done through I/O pins DB12 and DB13 as described in Notes 3~4 with LOAD tri-stating DB12 and DB13.

**Note 2:** OUTSEL=0 → 14-bit parallel output mode select; OUTSEL=1 → 8-bit nibble output mode select.

**Note 3:** For INSEL=1, DB12 becomes the SCLK input during serial programming.

**Note 4:** For INSEL=1, DB13 becomes the SDI input during serial programming.

**Note 5:** Pins 17, 20 and 23 may be connected to AGND2 to improve noise immunity.

## PIN CONFIGURATION

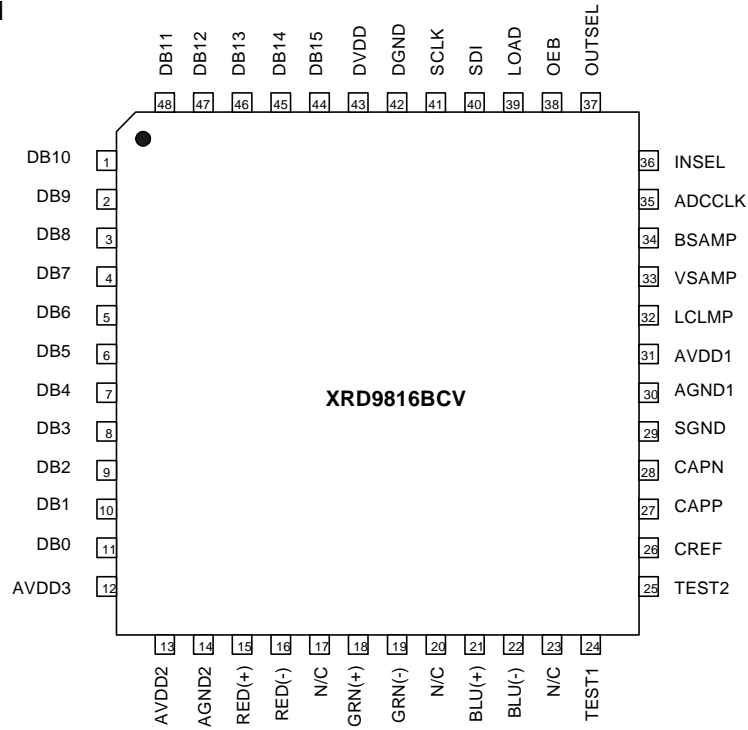

**Note:**  
Pins 17,20 and 23 should be connected to AGND2 to improve noise immunity

Pin No.	Name	Description
1	DB10	Data Output Bit 10
2	DB9	Data Output Bit9
3	DB8	Data Output Bit 8
4	DB7	Data Output Bit 7
5	DB6	Data Output Bit 6
6	DB5	Data Output Bit 5
7	DB4	Data Output Bit 4
8	DB3	Data Output Bit 3
9	DB2	Data Output Bit 2
10	DB1	Data Output Bit 1
11	DB0	Data Output Bit 0
12	AV <sub>DD3</sub>	Analog Power Supply
13	AV <sub>DD2</sub>	Analog Power Supply
14	AGND2	Analog Ground (Substrate)
15	RED(+)	Red Positive Analog Input

## Pin Configuration - XRD9816B

Pin No.	Name	Description
16	RED(-)	Red Negative Analog Input
17	N/C	No Connect, (Note 5)
18	GRN(+)	Green Positive Analog Input
19	GRN(-)	Green Negative Analog Input
20	N/C	No Connect, (Note 5)
21	BLU(+)	Blue Positive Analog Input
22	BLU(-)	Blue Negative Analog Input
23	N/C	No Connect, (Note 5)
24	TEST1	Internal Use Only
25	TEST2	Internal Use Only
26	CREF	Decoupling Cap for CDS Reference
27	CAPP	Decoupling Cap for Positive Reference
28	CAPN	Decoupling Cap for Negative Reference
29	SGND	Substrate Gnd
30	AGND1	Analog Ground (Substrate)
31	AV <sub>DD1</sub>	Analog Power Supply
32	LCLMP	Line Clamp Enable
33	VSAMP	Video Level Sampling Clock
34	BSAMP	Black Level Sampling Clock
35	ADCCLK	A/D Converter Clock
36	INSEL	Input Mode Select (Note 1)
37	OUTSEL	Output Mode Select (Note 2)
38	OEB	Data Output Enable
39	LOAD	Register Write Enable (Note 5)
40	SDI	Serial Data Input (Note 4)
41	SCLK	Serial Shift Clock (Note 3)
42	DGND	Ground (Output Drivers and Internal Decode Logic)
43	DV <sub>DD</sub>	Digital Power Supply (Output Drivers and Internal Decode Logic)
44	DB15	Data I/O Bit 15 (Note 4)
46	DB13	Data Output Bit 13
45	DB14	Data I/O Bit 14 (Note 3)
47	DB12	Data Output Bit 12
48	DB11	Data Output Bit 11

**Note 1:** INSEL=0 → SCLK, SDI, and LOAD pins are active for serial programming; INSEL=1 → SCLK and SDI pins are inactive, and the serial programming is done through I/O pins DB14 and DB15 as described in Notes 3–4 with LOAD tri-stating DB14 and DB15.

**Note 2:** OUTSEL=0 → 16-bit parallel output mode select; OUTSEL=1 → 8-bit nibble output mode select.

**Note 3:** For INSEL=1, DB14 becomes the SCLK input during serial programming.

**Note 4:** For INSEL=1, DB15 becomes the SDI input during serial programming.

**Note 5:** Pins 17, 20 and 23 may be connected to AGND2 to improve noise immunity.

## ELECTRICAL CHARACTERISTICS

$AV_{DD}=DV_{DD}=5.0V$ ,  $ADCCLK=6MHz$ , Input Range = 2V,  $T_a=25^{\circ}C$  unless otherwise specified

Parameter	Symbol	Min	Typ	Max	Unit	Conditions
<b>A/D CONVERTER</b>						
Resolution	R	14			BITS	XRD9814B
Resolution	R	16			BITS	XRD9816B
Maximum Conversion Rate	Fc	6	8		MSPS	
Differential Non-Linearity	DNL		+/-0.8		LSB	XRD9814B
Differential Non-Linearity	DNL		-0.95/+1.2		LSB	XRD9816B
Monotonicity	M		Yes			XRD9814B
Monotonicity	M		Yes			XRD9816B
Input Referred Offset	ZSE		40		mV	
Offset Drift	ZSD		15		$\mu V/^{\circ}C$	
Input Referred Gain Error	FSE		+/- 2		% FS	
Gain Error Drift	FSD		0.003		% FS $^{\circ}C$	
Input Voltage Range						
2V Full-Scale Range	IVR	0		2.0	V	PB5=0, Config Reg #1
3V Full-Scale Range	IVR	0		3.0	V	PB5=1, Config Reg #1
<b>CDS - S/H SPECIFICATIONS</b>						
Input Voltage Range						
Input Buffer Disabled (Note 1)	INVS	AGND		AVDD	V	Pixel Clamp, PB1=0, Config Reg #1
Input Buffer Enabled	INVS	0.5		AVDD-1	V	Line Clamp, PB1=1, Config Reg #1
Input Bias Current						
Input Buffer Disabled (Note 2)	IB		25		$\mu A$	Gain=1, PB1=0, Config Reg #1
Input Buffer Enabled	IB			25	nA	$T_a=70^{\circ}C$ , PB1=1, Config Reg #1
Input Switch On -Resistance	Ron		150	250	$\Omega$	Clamp Enabled
Input Switch Off -Resistance	Roff	100	1000		M $\Omega$	Clamp Disabled
Internal Voltage Clamp						
CCD Input (Inverting)	Vclamp	4.0	4.2	4.4	V	PB2=0, Config Reg #1
S/H Input (Non-Inverting)	Vclamp	0.6	0.8	1.0	V	PB2=1, Config Reg #1

**Note 1:**  $ADC\ digitizing\ range = (A/D\ Full-Scale\ Range/PGA\ Gain)$

**Note 2:** Due to switch capacitor input.

## ELECTRICAL CHARACTERISTICS (CONT'D)

AVDD=DVDD=5.0V, ADCCLK=6MHz, Ta=25C unless otherwise specified

Parameter	Symbol	Min	Typ	Max	Unit	Conditions
<b>OFFSET SPECIFICATIONS</b>						
Fine Offset Adjustment Min	OFR	-270	-300	-330	mV	8-Bit, 256 Settings
Fine Offset Adjustment Max	OFR	+270	+300	+330	mV	
Fine Offset Adjustment Step	OFRES		2.34		mV	
Fine Offset Adjustment	OFRL		+/-1.5%			
Linearity						
Gross Offset Adjustment Min	OFGR	-360	-400	-440	mV	2-Bit, 4 Settings
Gross Offset Adjustment Max	OFGR	+360	+200	+440	mV	
Gross Offset Adjustment Step	OFGRES		+200		mV	
<b>PGA SPECIFICATIONS</b>						
Gain Range Min (Absolute Value)	GRAN	1.0	1.10	1.20	V/V	-1 for PB2=0, +1 for PB2=1, Config Reg #1
Gain Range Max (Absolute Value)	GRAN	8.5	9.5	10.5	V/V	-10 for PB2=0, +10 for PB2=1, Config Reg#1
Gain Resolution	GRES		0.0083		V/V	10-Bit 1024 Steps
Gain DNL			+/-2.0		LSB	By design
<b>SYSTEM SPECIFICATIONS (Includes CDS, PGA and A/D)</b>						
Differential Non-Linearity	DNL	-0.9	+/-0.8	+1.5	LSB	XRD9814B, PGA Gain = 1
Differential Non-Linearity	DNL	-0.95	-0.95/+1.2	+2.0	LSB	XRD9816B, PGA Gain = 1
Integral Non-Linearity	INL		+/-10.0		LSB	XRD9814B, PGA Gain = 1
Input Referred Noise PGA Gain = -1.63	IRN <sub>min</sub>		+3.4		LSB	XRD9814B, 1-Channel CIS Mode, 6MSPS, Low Gain
PGA Gain = -5.0	IRN <sub>max</sub>		+1.1		LSB	XRD9814B, 1-Channel CIS Mode, 6MSPS, Low Gain
System Offset PGA Gain= -1	IRO <sub>min</sub>		+70		mV	XRD9814B/9816B, 3-Channel Mode, 6MSPS
PGA Gain= -10	IRO <sub>max</sub>		+70		mV	XRD9814B/9816B, 3-Channel Mode, 6MSPS

## ELECTRICAL CHARACTERISTICS (CONT'D)

AVDD=DVDD=5.0V, ADCCLK=6MHz, Ta=25C unless otherwise specified

Parameter	Symbol	Min	Typ	Max	Unit	Conditions
<b>TIMING SPECIFICATIONS</b>						
ADCCLK Pulse Width	tack	66.5			ns	
BSAMP falling edge delay from rising ADCCLK	tbfc	10			ns	
BSAMP falling edge to VSAMP falling edge.	tbvf	70			ns	
ADCCLK Period (1 Ch. Mode)	tcp1	166			ns	
ADCCLK Period (3 Ch. Mode)	tcp3	133			ns	
1-Channel Conversion Period	tcr1	166			ns	
3-Channel Conversion Period	tcr3	400			ns	
BSAMP Pulse Width	tpwb	30			ns	
VSAMP Pulse Width	tpwv	30			ns	
VSAMP falling edge to BSAMP falling edge.	tvbf	70			ns	
VSAMP falling edge delay from rising ADCCLK.	tvfcr	30			ns	All modes except 1-Channel S/H
VSAMP falling edge delay from rising ADCCLK	tvfcr	70			ns	1-Channel S/H, Config REG #1, PB2=1, PB7=1
PGA Settling Time	tstl	70			ns	
Aperture Delay	tap		5		ns	
<b>VSAMP TIMING OPTION #1</b>						
VSAMP rising edge delay from falling ADCCLK (Note 1)	tvrcf	15			ns	tvrcr is not required, Config REG #1, PB0=0
<b>VSAMP TIMING OPTION #2</b>						
VSAMP rising edge delay from rising ADCCLK (Note 1)	tvrcr	15			ns	tvrcf is not required, Config REG #1, PB0=1
<b>WRITE SPECIFICATIONS</b>						
Data Setup Time	tds	15			ns	
Data Hold Time	tdh	15			ns	
Load Setup Time	tlcs	15			ns	
Load Hold Time	tlch	15			ns	
Load Pulse Width	tplw	25			ns	

**Note 1:** VSAMP Timing Option #2 allows additional timing flexibility by allowing the rising edge of VSAMP to occur approximately one-half ADCCLK period earlier than Option #1. Option #2 is only available in 3-Channel Operation (PB4=0, PB3=0, Configuration Register #1).

## ELECTRICAL CHARACTERISTICS (CONT'D)

AVDD=DVDD=5.0V, ADCCLK=6MHz, Ta=25°C unless otherwise specified

Parameter	Symbol	Min	Typ	Max	Unit	Conditions
<b>DATA READBACK SPECIFICATIONS</b>						
Address Access Time	taa (1)		15		ns	
Output Enable Access Time	taoe (1)		15		ns	
<b>ADC DIGITAL OUTPUT SPECIFICATIONS</b>						
Output Delay	tod		20		ns	
Tri-State to Data Valid	tlz		8		ns	
Output Enable High to Tri-State	thz		8		ns	
Latency RGB inputs	lat		7		ADCCLK	
<b>DIGITAL INPUTS</b>						
Input High Logic Level	V <sub>IH</sub>	80			% DV <sub>DD</sub>	DV <sub>DD</sub> =3-5V
Input Low Logic Level	V <sub>IL</sub>			20	% DV <sub>DD</sub>	DV <sub>DD</sub> =3-5V
High Level Input Current	I <sub>IH</sub>		5		uA	
Low Level Input Current	I <sub>IL</sub>		5		uA	
Input Capacitance	C <sub>IN</sub>		10		pF	
<b>DIGITAL OUTPUTS (DV<sub>DD</sub>=5V)</b>						
Output High Voltage	V <sub>OH</sub>	4.2			V	IL=2ma
Output Low Voltage	V <sub>OL</sub>			0.4	V	IL=-2ma
Output Capacitance	C <sub>OUT</sub>		10		pF	
<b>DIGITAL OUTPUTS (DV<sub>DD</sub>=3.3V)</b>						
Output High Voltage	V <sub>OH</sub>	2.8			V	IL=2ma
Output Low Voltage	V <sub>OL</sub>			0.3	V	IL=-2ma
Output Capacitance	C <sub>OUT</sub>		10		pF	
<b>POWER SUPPLY</b>						
Analog Power Supply	AV <sub>DD</sub>	4.5	5.0	5.5	V	3CH CDS Mode Digital Output CLoad=30pF, all pins.
Digital Power Supply	DV <sub>DD</sub>	3.0	5.0	5.5	V	
Analog Supply Current	IDDA		110		mA	
Digital Supply Current	IDDD		2		mA	
Stand-By Mode Power	PDoff		65	80	mW	

**Note 1:** Start of valid data depends on which timing becomes effective last, taoe or taa.

Function	A2	A1	A0	PB9-PB0
Configuration Reg #1	0	0	0	See Configuration Register #1
Configuration Reg #2	0	0	1	See Configuration Register #2
Red Gain	0	1	0	10-Bit Gain
Green Gain	0	1	1	10-Bit Gain
Blue Gain	1	0	0	10-Bit Gain
Red Offset	1	0	1	2-Bit Gross Offset Adjustment: 8-Bit Fine Offset Adjustment
Green Offset	1	1	0	2-Bit Gross Offset Adjustment: 8-Bit Fine Offset Adjustment
Blue Offset	1	1	1	2-Bit Gross Offset Adjustment: 8-Bit Fine Offset Adjustment

**Table 1. XRD9814B/9816B Register Overview**

A2 A1 A0 Address	Bit Assignment	PB9-PB0 Bit Definition
0 0 0	<b>PB9</b> Single Channel Power Save Mode	0 Unused channels are powered down to 0 save power (single channel mode only) 1 Unused channels are powered up
	<b>PB8</b> Digital Reset	0 No Reset 1 Resets all registers to the default configuration
	<b>PB7 PB6</b> Clamp Mode	00 CDS pixel 01 CDS line clamp 10 No clamp 11 S/H line clamp
	<b>PB5</b> A/D Full Scale Range	0 2Vpp Full Scale 1 3Vpp Full Scale (recommended for better performance)
	<b>PB4 PB3</b> Color Select	00 RGB 3 channel color mode 01 Red single channel mode 10 Green single channel mode 11 Blue single channel mode
	<b>PB2</b> Input Signal Polarity	0 Inverted for CCD or negative going signals 1 Non-inverted for CIS or positive going signals
	<b>PB1</b> Input Buffer Enable	0 No buffer (DC coupled or AC coupled inputs with pixel clamp mode) 1 Buffer enabled (AC Coupled inputs for line clamp or no clamp mode)
	<b>PB0</b> VSAMP Timing	0 Timing option #1 (see Figure 3, 4, 7 & 8 for details) 1 Timing option #2 (see Figure 3, 4, 7 & 8 for details)

**Table 2. Configuration Register #1 Definition (Default Configuration is 000H)**

A2 A1 A0 Address	Bit Assignment	PB9-PB0 Bit Definition
0 0 1	<b>PB9</b> Not Used	0 Normal This register should be set to zero for normal operation 1 Do Not Use
	<b>PB8</b> Not Used	0 Normal This register should be set to zero for normal operation 1 Do Not Use
	<b>PB7</b> Not Used	0 Normal This register should be set to zero for normal operation 1 Do Not Use
	<b>PB6</b> Not Used	0 Normal This register should be set to zero for normal operation 1 Do Not Use
	<b>PB5</b> Not Used	0 Normal This register should be set to zero for normal operation 1 Do Not Use
	<b>PB4 PB3</b>  CDS Clamp Voltage (Black Level)	00 $AV_{DD}-0.8V$ (4.2V for AVDD = 5V) (See Figures 11 & 12 for VClamp Settings) 01 $AV_{DD}-1.3V$ (3.7V for AVDD = 5V) 10 $AV_{DD}-1.8V$ (3.2V for AVDD = 5V) 11 $AV_{DD}-2.3V$ (2.7V for AVDD = 5V)
	<b>PB2</b> Not Used	0 Normal This register should be set to zero for normal operation 1 Do Not Use
	<b>PB1</b> Stand-By Mode	0 All circuits active 1 Low power mode (75mW, requires 5uS back to normal operation)
	<b>PB0</b> Read Back Mode	0 A/D digital outputs 1 Read back mode (A2:A1:A0 select register data)

**Table 3. Configuration Register #2 Definition (Default Configuration is 000H)**

A2	A1	A0	Function	PB9	PB8	PB7	PB6	PB5	PB4	PB3	PB2	PB1	PB0
0	1	0	Red Gain	MSB									LSB
0	1	1	Green Gain	MSB									LSB
1	0	0	Blue Gain	MSB									LSB
1	0	1	Red Offset PB9-PB8 gross adj PB7-PB0 fine adj	00 0V 01 +200mV 10 -200mV 11 -400mV		MSB							LSB
1	1	0	Green Offset PB9-PB8 gross adj PB7-PB0 fine adj	00 0V 01 +200mV 10 -200mV 11 -400mV		MSB							LSB
1	1	1	Blue Offset PB9-PB8 gross adj PB7-PB0 fine adj	00 0V 01 +200mV 10 -200mV 11 -400mV		MSB							LSB

**Table 4. Gain and Offset Registers (Default Configuration is 000H)**

## GENERAL DESCRIPTION

The XRD9814B/9816B contains all of the circuitry required to create a complete 3-channel signal processor /digitizer for use in CCD/CIS imaging systems. Each channel includes a correlated double sampler (CDS), programmable gain amplifier (PGA) and channel offset adjustment. The input stage can also be configured for use with inverting/non-inverting, AC or DC coupled signals. In order to maximize flexibility, the specific operating mode is programmable through two configuration registers. In addition, the gain and offset of each channel can be independently programmed through separate gain and offset registers. Configuration register data is loaded serially through a 3-pin serial interface. Specific details for register writes are detailed below. After signal conditioning the three PGA outputs are digitized by a 14-bit/16-bit A/D converter.

### Writing Registers Data

The XRD9814B/9816B utilizes eight 10-Bit registers to store configuration, gain and offset information. Register data is written through the 3-pin serial interface consisting of SDI (serial data input), SCLK (serial shift clock) and LOAD (positive edge write enable). A write consists of pulling LOAD low, shifting in 3 bits of address (MSB first) and 10 bits of data (MSB first). Data is written on the rising edge of SCLK and the last 13 bits are latched. The timing for writing to registers is shown in Figure 17 and 18.

When INSEL=0, SCLK, SDI, and LOAD pins are active for serial programming.

When INSEL=1, SCLK and SDI pins are inactive, and the serial programming is done through I/O pins DB12/DB14 and DB13/DB15 while LOAD pin is low.

### Configuration Register #1

The bit assignment and definition for this register is detailed in the Configuration Register #1 Definition Table (Table 2). The primary purpose of this register is to configure the analog input blocks for CCD or S/H operation.

### Clamp Mode

The clamp mode setting determines the conditions when the internal clamp is enabled (see Table 5). The pixel and CCD line-clamp modes are used to DC-restore AC coupled CCD input signals to the PGA common-mode input voltage while using correlated double sampling. S/H line mode should be used to DC-restore AC coupled inputs which do not utilize correlated double sampling and have only one control input (VSAMP). No-clamp mode should be used for DC coupled S/H inputs.

### Pixel Mode (CCD with CDS)

The input clamp is active each pixel period with a pulse-width determined by the Black- level Sampling Input (BSAMP). The position of BSAMP can be optimized to eliminate the effects of the CCD reset pulse. Since the input capacitor is recharged to the clamp voltage on each pixel, common-mode droop errors are eliminated.

### CCD Line Mode (CCD with CDS)

The input clamp is enabled only at the beginning of the line by gating BSAMP with LCLMP. Gating with LCLMP maintains the ability to position the clamp pulse (BSAMP) away from the CCD reset for varying LCLMP position and width. Since the input capacitor is clamped only at the beginning of each line a larger input capacitor is required to satisfy the common-mode input requirements of the analog front-end. (See Coupling Capacitor Requirements.) The input buffer should be enabled in this mode (PB1=1, Register #1).

### S/H Line Mode (S/H with AC Coupling)

The S/H Line mode clamp is used to DC-restore AC coupled inputs which do not utilize CDS. VSAMP is used to sample and hold the input signal and LCLMP performs the clamp function. This differs from the CDS line and pixel modes which use BSAMP to clamp to the reference level and VSAMP to hold the video input. The input buffer should be enabled in this mode (PB1=1, Register #1).

### No-Clamp Mode (S/H with DC input)

Used for DC coupled inputs. AC coupled inputs must be externally clamped to the proper common-mode input voltage of the XRD9814B/9816B.

**Note:** Pixel clamp is the default clamp mode.

Clamp Mode	PB7	PB6	Clamp Enable
Pixel	0	0	$BSAMP$
CDS Line	0	1	$BSAMP \cdot \overline{LCLMP}$
No Clamp	1	0	Disabled
S/H Line	1	1	$\overline{LCLMP}$

**Table 5. Clamp Enable Definition**

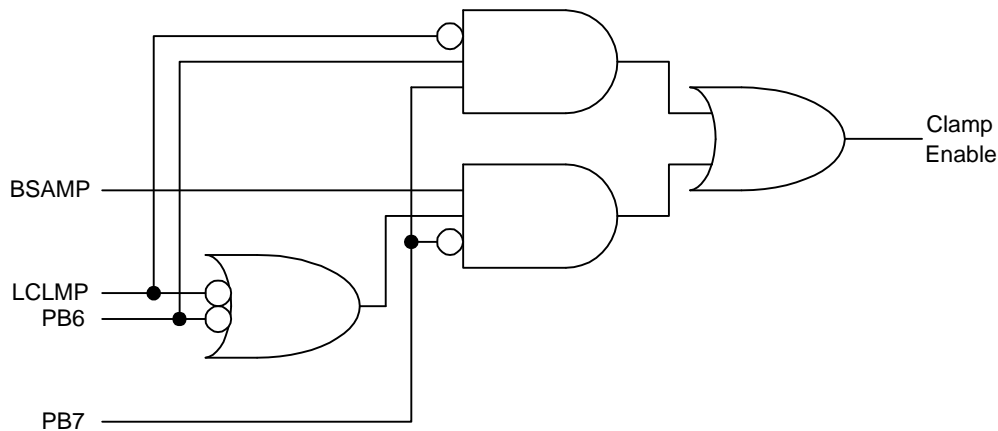

**Figure 2. Clamp Enable Logic**

### A/D Full-Scale Range

This bit sets the Full-Scale Range (FSR) of the A/D converter to 2V or 3V. Use the 3V FSR for lowest noise performance.

### Color Select

The color input corresponds to the signal input to be digitized by the A/D converter. If set to RGB (default) the A/D input is sequentially cycled through the red, green and blue channels. The green channel is synchronized on the rising edge of the first ADCCLK after the falling edge of VSAMP. If set in single-channel mode, the A/D multiplexer will not sequence and the A/D converter input will be continually connected to the channel that is selected, RED, GRN or BLU.

### Signal Polarity

This bit configures the analog inputs for positive or negative transitioning inputs. This is required to provide the correct signal polarity to the A/D input and to set the correct input clamp level. The default configuration is set to inverting mode (CCD input).

### Input Buffer Enable

This bit enables the input buffer to the PGA amplifier and is required only for AC coupled inputs operating in CDS line or S/H line clamp modes. Since this input buffer reduces the input voltage range its use is not recommended under DC or pixel-mode operation. The input buffer is disabled in the default configuration.

## VSAMP Timing

This allows the user to select one of two VSAMP timing controls. Timing Option #2 allows the rising edge of VSAMP to occur approximately one-half ADCCLK earlier than Option #1. This does not affect internal timing and is provided only to allow additional flexibility in the external timing control. Timing Option #2 is available only in the 3-channel mode of operation (See timing diagrams Figure 3 and Figure 4).

## Configuration Register #2

The bit assignment and definition for this register is detailed in the Configuration Register #2 Definition Table. A diagnostic read-back mode allows gain, offset and configuration data to be output as the 8 or 10 MSBs on the digital output bus depending on the selection of OUTSEL (see Reading Register Data session for details). Additional bits are used to enable a low-power stand-by state and manufacturing test mode.

## Digital Reset

Setting this bit to one resets all registers to all zeros.

## Test Mode

This is a reserved bit for testing and must be set to 0 in all writes to Configuration Register #2.

## Stand-By Mode

Setting this bit to one forces the circuit into a low-power standby mode. Configuration, offset and gain registers remain unchanged in stand-by mode. Pull OEB High to set DB<15:0> to high impedance during stand-by mode.

## Read Back Mode

This is a special diagnostic mode which can aid in the debugging of new system designs. Setting this bit to 1 allows all configuration, gain and offset register contents to be output on the data output bus (explained below).

## Reading Register Data

In order to enter read-back mode, set configuration register #2, PB0 to 1. Follow the write timing in Figures 17 and 18.

In order to read a specific register, shift in 3-bits of register address data (MSB first), followed by 10 dummy data bits. In the case of reading back configuration register #2, PB0 has to stay 1 and cannot be a dummy.

### Read-Back Registers and Address

Address	Data	Register
001	XXXXXXXXXX	Cfig1
001	XXXXXXXXX1	Cfig2
010	XXXXXXXXXX	Red Gain
011	XXXXXXXXXX	Grn Gain
100	XXXXXXXXXX	Blu Gain
101	XXXXXXXXXX	Red Offset
110	XXXXXXXXXX	Grn Offset
111	XXXXXXXXXX	Blu Offset

In order to exit read-back mode perform a write to configuration register 2, PB0=0.

(OUTSEL = 0) In read-back mode the A/D output is bypassed and internal register data is output to the 10 most significant bits of the data output bus. The remaining LSB bits should be ignored. Register data will be valid after the load pin goes high.

(OUTSEL = 1) In nibble mode, the output bus is limited to 8-bits. Therefore, in read-back mode, the 8 MSBs are valid when ADCCLK is high, and the 2 LSBs are valid when ADCCLK is low. Configuring and exiting the read-back mode is done in the same manner of OUTSEL = 0.

**Important:** The entire byte of register #2 is re-written when exiting the readback mode. If any bits of configuration register #2 were programmed prior to entering the read-back mode, they must be re-programmed when exiting read-back. See Figure 19 for read-back timing.

## PGA Gain Settings

The gain for each color input is individually programmable from 1 to 10 in 1024 linear steps.

$$PGA\ Gain = \left( \frac{Code}{1024} \right) \cdot 9.0 + 1$$

where Code represents the binary contents of the 10-bit gain setting register.

### Channel Offset Adjustment

The gross offset correction for each channel is programmable from -400mV to +200mV. It is adjusted by toggling PB9 and PB8 of Offset Registers (Table 4).

The fine offset correction for each channel is programmable from -300mV to +300mV.

$$Fine\ Channel\ Offset = PB7 \cdot \left[ \frac{(Code)}{128} \right] \cdot 300mV$$

PB7=1 equals -1

PB7=0 equals +1

Code = (PB6:PB0) of the 10-bit offset register.

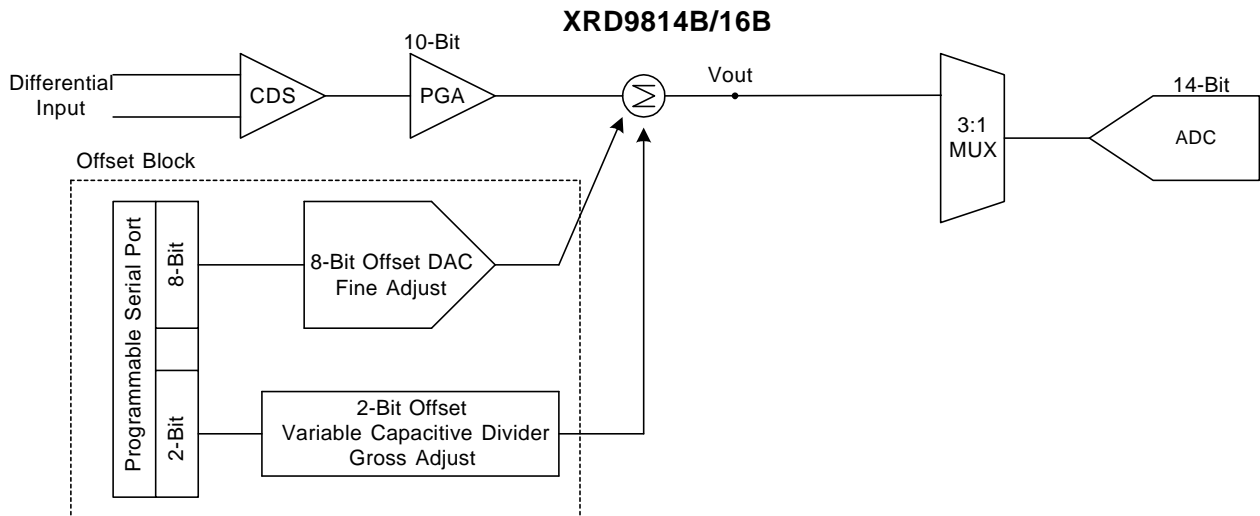

**Block Diagram of the Fine and Gross Offset Adjustment DAC**

## (Correlated Double Sampling)

Correlated double sampling is a technique used to level shift and acquire CCD output signals whose information is equal to the difference between consecutive reference (black) and signal (video) samples. The CDS process consists of three steps:

- 1) Sampling and holding the reference black level.
- 2) Sampling the video level.
- 3) Subtracting the two samples to extract the video information.

Once the video information has been extracted it can be processed further through amplification and/or offset adjustment. Since system noise is also stored and subtracted during the CDS process, signals with bandwidths less than half the sampling frequency will be substantially attenuated.

In order to reject higher frequency power supply noise which is not attenuated near the sampling frequency the XRD9814B/9816B utilizes a fully differential input structure.

Since the CDS process uses AC coupled inputs the coupling capacitor must be charged to the common-mode range of the analog front-end. This can be accomplished by clamping the coupling capacitor to the internal clamp voltage when the CCD is at a reference level. This clamp may occur during each pixel (Pixel Clamp), or at the beginning of each line (CDS Line Clamp). If CDS Line Clamp mode is used the input buffer (configuration register #1, PB1) must be enabled to eliminate the effects of input bias current. If Pixel mode is selected the input buffer is not required or recommended.

## 3-Channel CDS Mode

This mode allows simultaneous CDS of the red, green and blue inputs. Black-level sampling occurs on each pixel and is equal to the width of the BSAMP sampling input. The black level is held on the falling edge of BSAMP and the PGA will immediately begin to track the signal input until the falling edge of VSAMP.

Two VSAMP timing modes are supported to allow additional flexibility in the VSAMP pulse width (see timing diagrams). At the end of the video sampling phase the difference between the reference and video levels is inverted, amplified and offset depending on the contents of the PGA gain and offset registers. The RGB channels are then sequentially converted by a high speed A/D converter. A/D converter data appears on the data output bus after 7 ADCCLK cycles. The green channel is synchronized on the rising edge of the first ADCCLK after the falling edge of VSAMP. The power-up default mode is for CDS sampling a CCD input (Pixel Clamp, Inverting Input, No Input Buffer).

## 1-Channel CDS Mode

The 1-Channel CDS mode allows high-speed acquisition and processing of a single channel. The timing, clamp and buffer configurations are similar to the 3-channel mode described previously. To select a single channel input the color bits of configuration register 1 must be set to the appropriate value. The A/D input will begin to track the selected color input on the next positive edge of ADCCLK. If the configuration is toggled from single color to 3-channel mode RGB scanning will not occur until the circuit is resynchronized on the falling edge of VSAMP.

### 3-Channel CIS/Sample and Hold Mode

The XRD9814B/9816B also supports operation for Contact Image Sensor (CIS) and S/H applications. The green channel is synchronized on the rising edge of the first ADCCLK after the falling edge of VSAMP.

For DC coupled inputs the reference clamp and input buffer should be disabled and input polarity should be set to 1 (non-inverting). In this mode of operation the BSAMP input is connected to DGND and input sampling occurs on the falling edge of VSAMP.

When using AC coupled inputs the coupling capacitor must be clamped to the required common-mode input voltage when the signal source output is at a reference level. This can be accomplished by enabling the S/H Line clamp mode in configuration register 1 and clamping the input capacitor to the internal clamp voltage at the beginning of each line via the LCLMP input. The required width of the LCLMP signal is dependent on the value of the coupling capacitor, XRD9814B/9816B clamp resistance, source output resistance and desired accuracy. This is explained further in Coupling Capacitor Requirements. If AC coupling is used the input buffer (configuration register 1) must be enabled to eliminate input-bias current errors inherent to the sampling process. The input buffer is not required or recommended in DC coupled applications.

### 1-Channel CIS/ Sample and Hold Mode

The 1-channel CIS S/H mode allows high-speed acquisition and processing of a single channel. The timing, clamp and buffer configurations are similar to the 3-channel mode with the exception that VSAMP timing option #2 is not supported. To select a single channel input the color bits of configuration register 1 must be set to the appropriate value. The A/D input will begin to track the selected color input on the next positive edge of ADCCLK. If the configuration is toggled from single color to 3-channel mode, RGB scanning will not occur until the circuit is resynchronized.

### Power Supplies and Digital I/O

The XRD9814B/9816B utilizes separate analog and digital power supplies. All digital I/O pins are 3V/5V compatible and allow easy interfacing to external digital ASICs. For single supply systems the analog and digital supply pins can be separately connected and bypassed to reduce noise coupling from digital to analog circuits.

### Coupling Capacitor Requirements

The size of the external coupling capacitors depends on a number of items including the clamp mode, pixel rate, channel gain, black-level variation and system accuracy requirements. The major limitation for each clamp mode is shown below:

	CDS Mode	S/H Mode
Pixel Clamp (Buffer Disabled)	Black level pixel-pixel variation  Initial charging	Not Applicable
Line Clamp (Buffer Enabled)	Initial charging Capacitor droop (common-mode range)	Initial charging Capacitor droop range (accuracy error)

**Table 5. Coupling Capacitor Limitation**

## Maximum Capacitance (CDS Pixel Mode)

### Limitation #1

Since the black level is clamped during each pixel period the input bias current contributes an insignificant amount of droop during one pixel period. However, pixel-pixel variations in the black level may appear as errors. For a worst case gain of -10, 2V A/D FSR and 14-bit accuracy, one lsb of error corresponds to 12.5uV input-referred. Assuming 1mV of pixel-pixel variation in the black level, the maximum coupling capacitor can be determined as a function of the clamping period and internal clamp resistance.

$$C_{max} = \frac{tpwb}{(Rc + Rs) \cdot \ln\left(\frac{1mV}{12.5mV}\right)}$$

where tpwb=clamp pulse width (BSAMP)

Rc=Clamp resistance

Rs=Signal source-resistance

For typical values of tpwb=65ns, Rc=100Ω, Rs=50Ω,  $C_{MAX} \leq 100pF$ .

### Limitation #2

The maximum input capacitance may also be limited by the time allowed to charge the input capacitor to the difference between the black level and clamp levels. The capacitor value can be related to the number of clamp pulses allowed before the capacitor voltage settles to within the desired accuracy.

$$C_{max} = \frac{tpwb \cdot N}{(Rc + Rs) \cdot \ln\left(\frac{Vr - Vc}{Ve}\right)}$$

where tpwb = clamp pulse width (BSAMP)

N = number of pixels allowed to settle

Rc = clamp resistance

Rs = signal source-resistance

Vr = black level

Vc = XRD9814B/9816B clamp voltage

Ve = error voltage

Assuming that Vr=5V, Vc=4V, Ve=12.5uV, Rc=100Ω, Rs=50Ω, tpwb=65ns and N=10 the maximum allowable input capacitor is equal to 384pF. In this case the input capacitance is limited by pixel-pixel changes in the black level (first calculation).

## Minimum Capacitance (CDS Pixel Mode)

The minimum coupling capacitance is limited by parasitic effects including pin and board capacitance. A minimum value of 68pF is recommended.

## Maximum Capacitance (CDS Line Mode)

Since the coupling capacitor is charged only at the beginning of each line and not clamped at each pixel, the pixel-pixel variation in the black level has no effect on the capacitor size. The maximum size will be limited by the number of clamp pulses, clamp pulse-width and number of lines allowed to charge to a given accuracy.

$$C_{max} = \frac{N \cdot L \cdot tpwb}{(Rc + Rs) \cdot \ln\left(\frac{Vr - Vc}{Ve}\right)}$$

where tpwb = clamp pulse width (BSAMP)

N = number of pixels allowed to settle

Rc = clamp resistance

Rs = signal source-resistance

Vr = black level

Vc = XRD9814B/9816B clamp voltage

Ve = error voltage

Assuming that Vr=5V, Vc=4V, Ve=12.5uV, Rc=100Ω, Rs=500Ω, tpwb=65ns and N=10, the maximum allowable input capacitor is equal to 767pF.

If it is desired to settle within one line (L=1) for a given capacitor value, the number of clamp pulses or the clamp pulse-width must be increased using the above equation.

## Minimum Capacitance (CDS Line Mode)

In general, the minimum value coupling capacitance is limited by the amount of droop which can occur before the input voltage range of the input amplifier is exceeded. The input capacitor droop is related to the input bias current by:

$$V_{droop} = \frac{I_{bias} \cdot n \cdot T}{C}$$

where  $I_{bias}$  = input bias current  
 $n$  = number of pixels per line  
 $T$  = pixel period

If the minimum input voltage is allowed to equal the 0V input voltage of the XRD9814B/9816B, the maximum allowable droop will be equal to the clamp level minus the difference between the black and video levels. For example, if  $V_c=4V$ , and the CCD video output is -2V relative to the black level the maximum allowable droop is equal to 2V.

Using the previous equation and assuming  $T=500ns$ ,  $n=3000$

$$C_{min} = \frac{10nA \times 3000 \times 500ns}{2V} = 7.5pF$$

**Note:** These are the absolute minimum capacitor requirements. As stated for pixel-mode, a minimum value of 68pF is recommended.

## Minimum Capacitance (S/H Line Mode)

Unlike Line or Pixel CDS modes voltage droop across a line appears as an absolute error and is the dominant factor in determining the minimum coupling capacitor size.

$$C_{min} = \frac{I_{bias} \times n \times T}{V_e}$$

where  $I_{bias}$  = input bias current  
 $n$  = number of pixels per line

Assuming  $n=3000$ ,  $T=500nS$ ,  $I=10nA$  and  $V_e=12.5uV$ , the minimum required capacitor is 1.2uF.

## Maximum Capacitance (S/H Line Mode)

The maximum capacitance is determined by the amount of time allowed to charge the coupling capacitor. In order to minimize the charging time, the maximum capacitor can be set to the minimum value as previously calculated. In this case the time required to charge the capacitor is:

$$t = (R_s + R_c) \times C_{min} \times \ln\left(\frac{V_r - V_c}{V_e}\right)$$

where  $t$  = clamp pulse - width ( $\overline{SYNCH}$ )  
 $R_c$  = clamp resistance  
 $R_s$  = signal source - resistance  
 $V_r$  = input reference level  
 $V_c$  = XRD9814B/9816B clamp voltage  
 $V_e$  = error voltage  
 $C_{min}$  = coupling capacitor

Assuming that  $V_r=.5 V_c=0V$ ,  $V_e=12.5uV$ ,  $R_c=100\Omega$ ,  $R_s=500\Omega$  and  $C=1.2uF$ , the minimum clamp period is equal to 1.9mS.

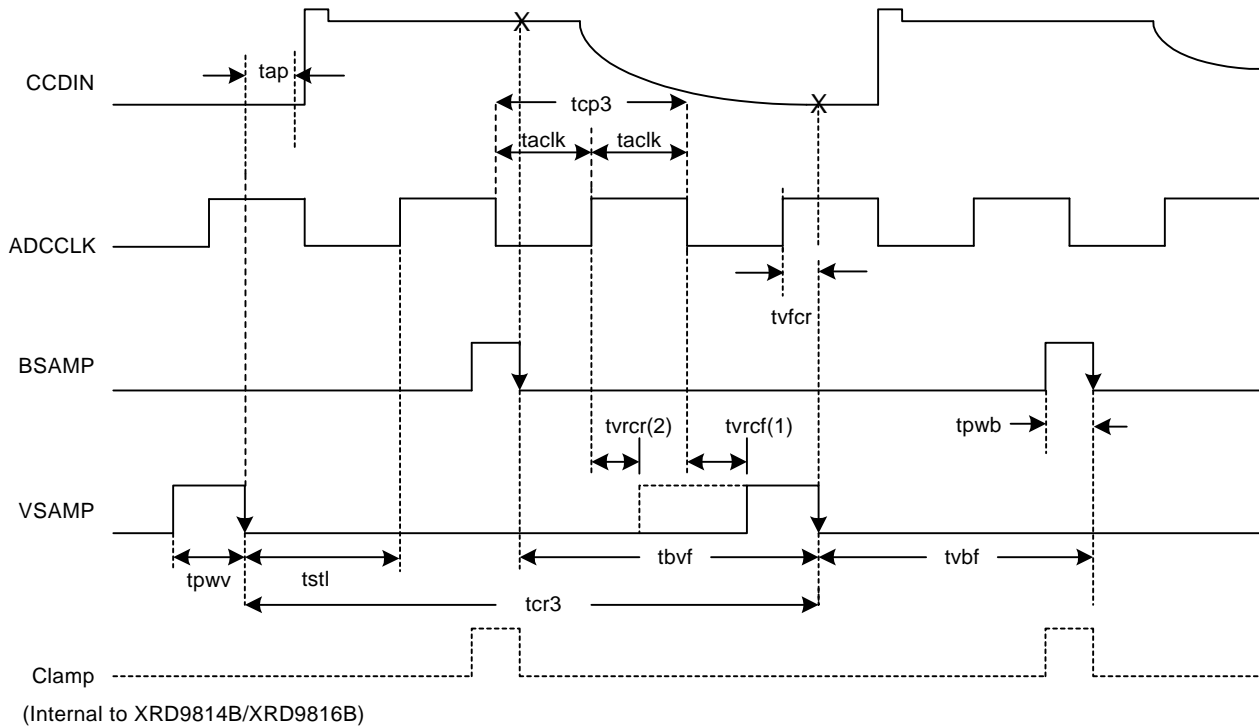

**Notes:** (1) VSAMP Timing Option #1 uses tvrcf (tvrcr is not required)  
 (2) VSAMP Timing Option #2 uses tvrcr (tvrcf is not required)  
 VSAMP Timing Option #2 only available in 3-Channel Operation

**Figure 3. 3-Channel CDS Mode - Pixel Clamp**

Configuration Register #1: Pixel Clamp (PB7=0, PB6=0)  
 RGB (PB4=0, PB3=0)  
 Inverted Polarity (PB2=0)  
 Input Buffer Disabled (PB1=0)

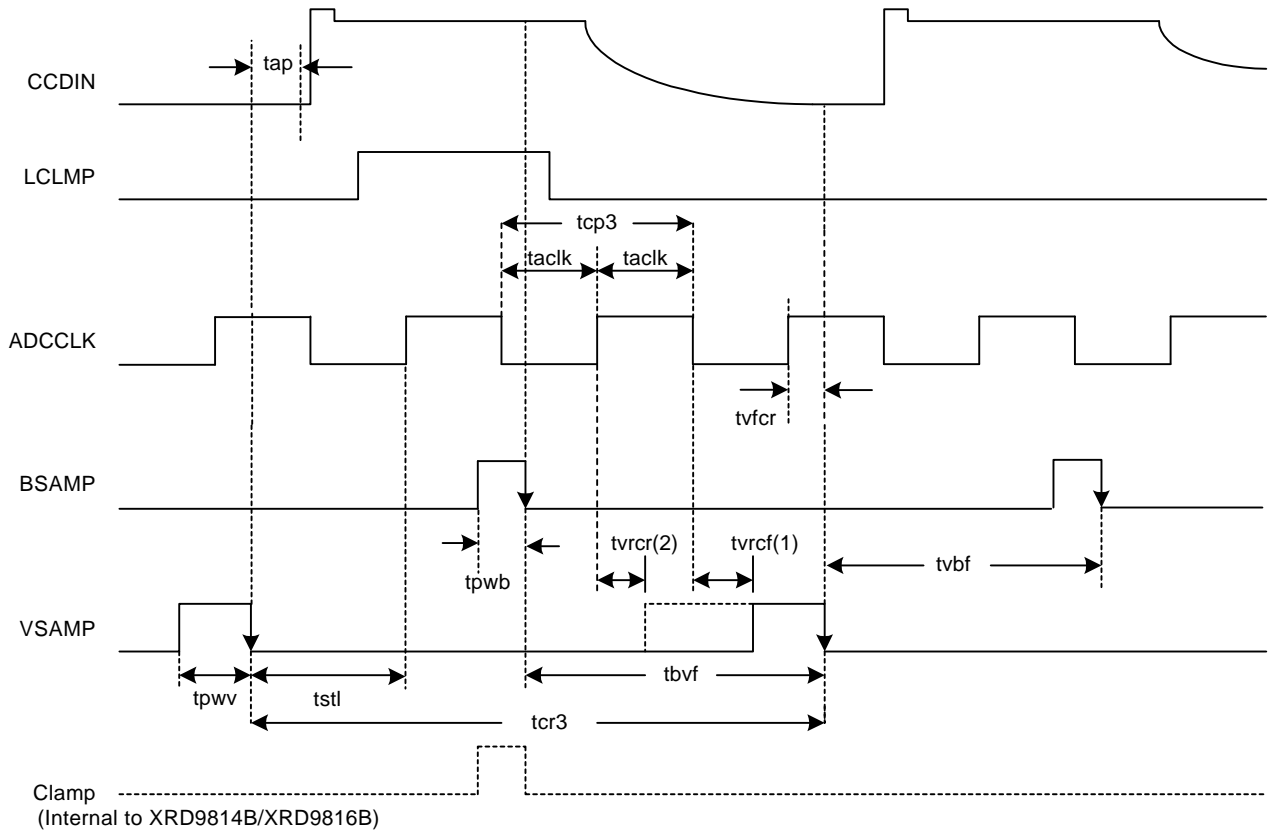

**Notes:** (1) VSAMP Timing Option #1 uses tvrcf (tvrcr is not required)  
 (2) VSAMP Timing Option #2 uses tvrcr (tvrcf is not required)  
 VSAMP Timing Option #2 only available in 3-Channel Operation

**Figure 4. 3-Channel CDS Mode - Line Clamp**

Configuration Register #1: CDS Line (PB7=0, PB6=1)  
 RGB (PB4=0, PB3=0)  
 Inverted Polarity (PB2=0)  
 Input Buffer Enabled (PB1=1)

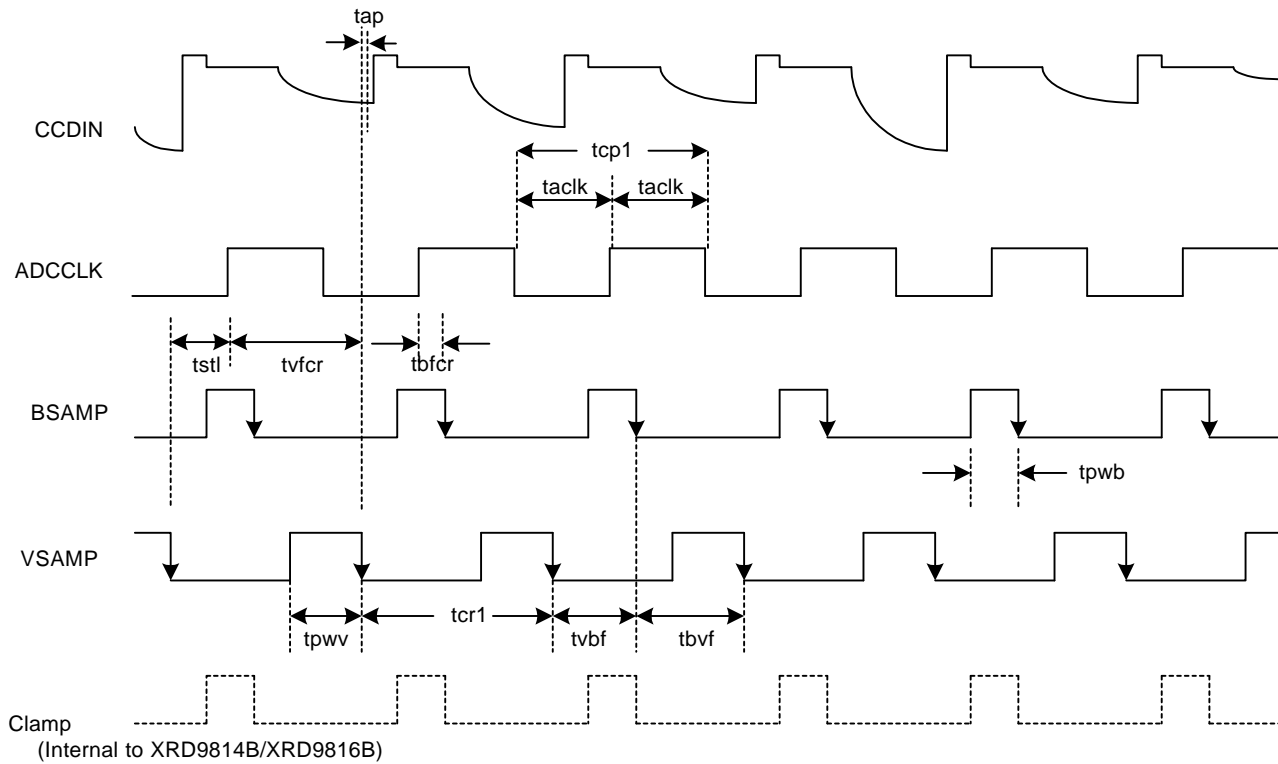

**Figure 5. 1-Channel CDS Mode - Pixel Clamp**

Configuration Register #1: Pixel Clamp (PB7=0, PB6=0)  
 Single Channel (PB4, PB3-RED 01, GRN 10, BLU 11)  
 Inverted Polarity (PB2=0)  
 Input Buffer Disabled (PB1=0)

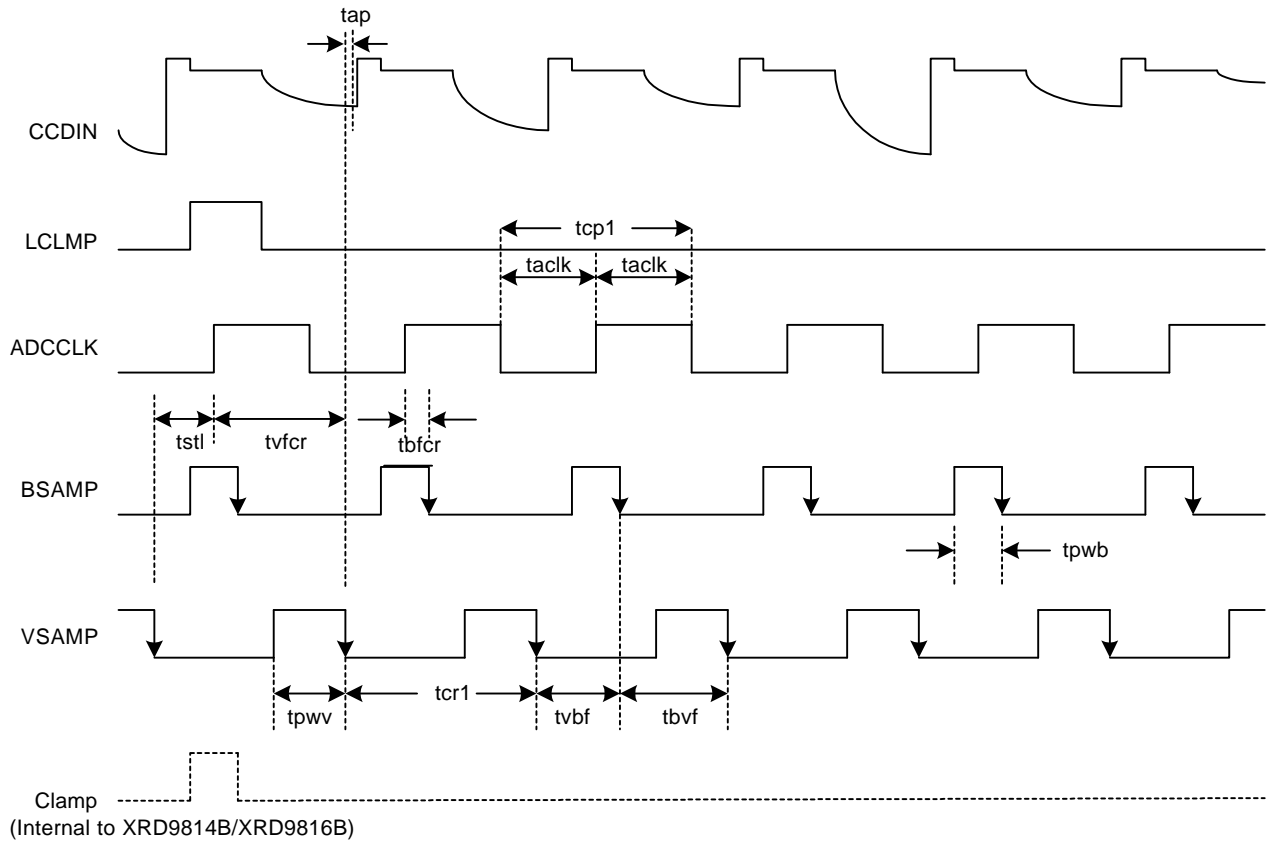

**Notes:** (1) Only VSAMP timing option #1 is supported in 1-channel mode

**Figure 6. 1-Channel CDS Mode - Line Clamp**

Configuration Register #1: CDS Line Clamp (PB7=0, PB6=1)  
 Single Channel (PB4, PB3-RED 01, GRN 10, BLU 11)  
 Inverted Polarity (PB2=0)  
 Input Buffer Enabled (PB1=1)

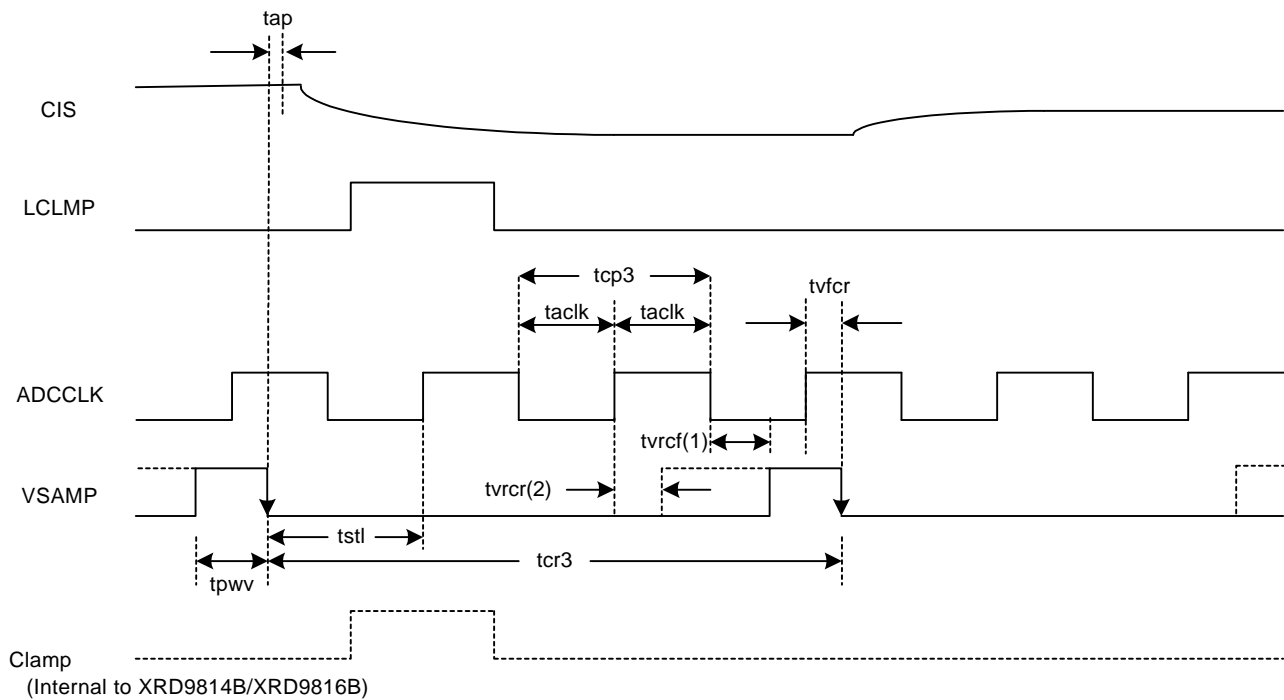

**Figure 7. 3-Channel S/H Mode - Line Clamp (AC Coupled)**

Configuration Register #1: S/H Line Clamp (PB7=1, PB6=1)  
 RGB (PB4=0, PB3=0)  
 Non-Inverted Polarity (PB2=1)  
 Input Buffer Enabled (PB1=1)

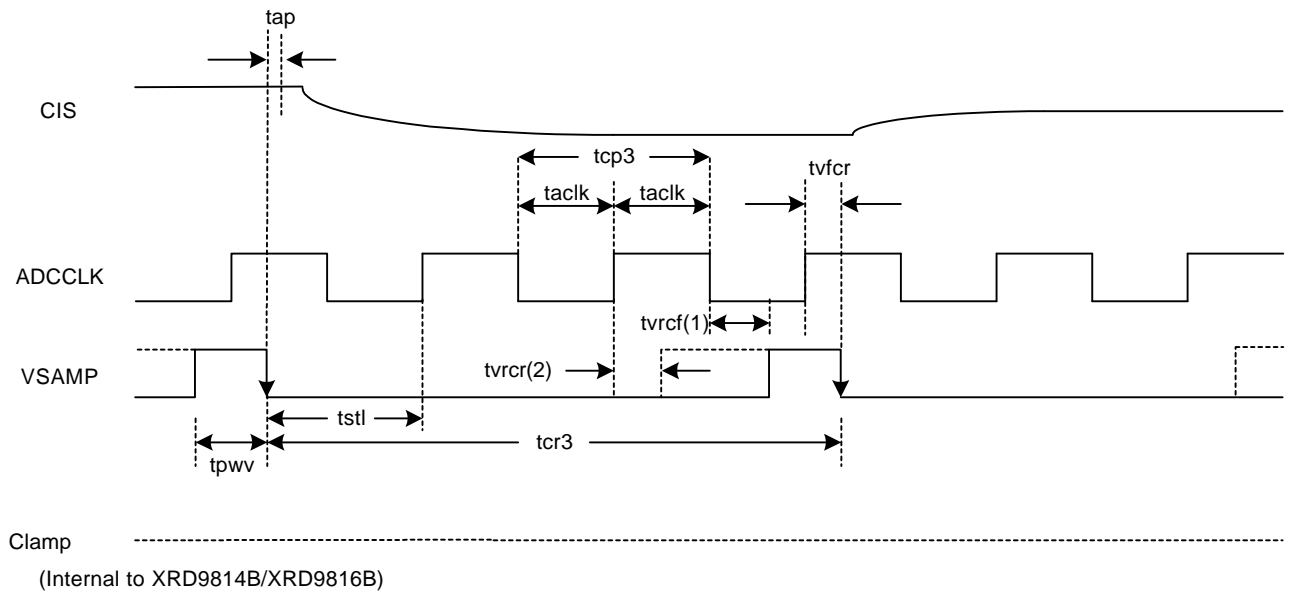

**Notes:** (1) VSAMP Timing option #1 uses tvrcf (tvrcr is not required)  
 (2) VSAMP Timing option #2 uses tvrcr (tvrcf is not required)

**Figure 8. 3-Channel S/H Mode - No Clamp (DC Coupled)**

Configuration Register #1: S/H No Clamp (PB7=1, PB6=0)  
 RGB (PB4=0, PB3=0)  
 Non-Inverted Polarity (PB2=1)  
 Input Buffer Disabled (PB1=0)

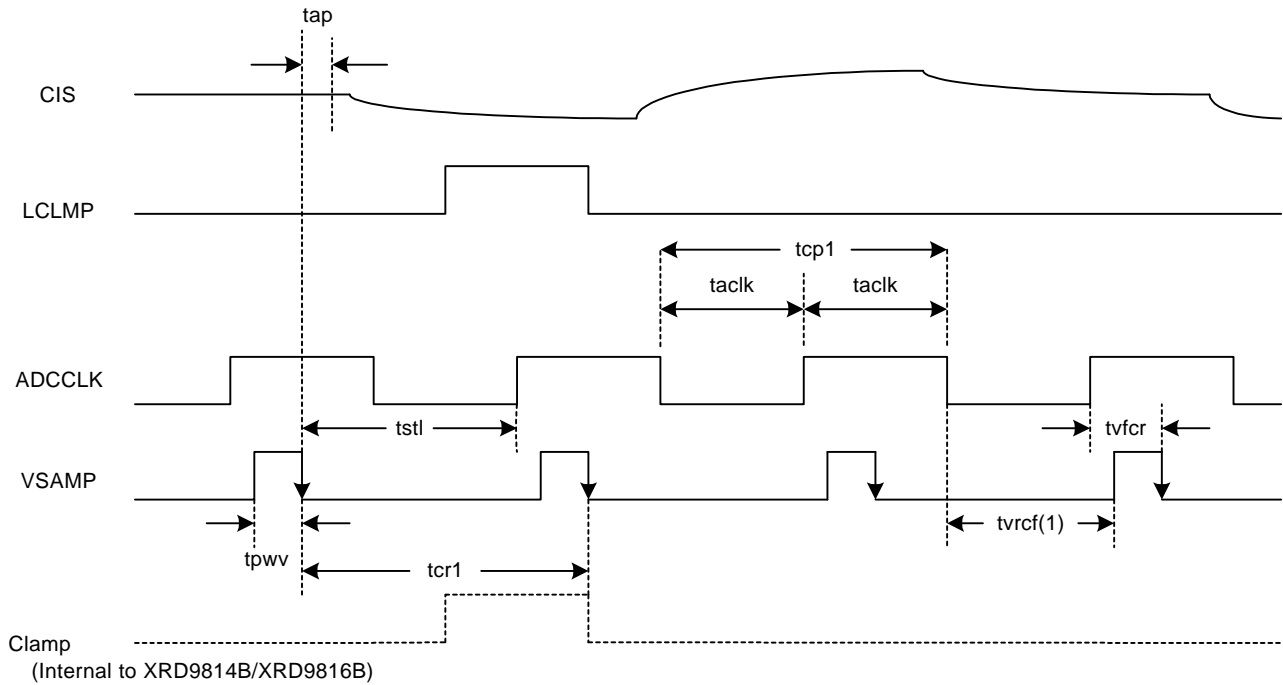

**Figure 9. 1-Channel S/H Mode - Line Clamp (AC Coupled)**

Configuration Register #1: S/H Line Clamp (PB7=1, PB6=1)  
 Single Channel (PB4, PB3-RED 01, GRN 10, BLU 11)  
 Non-Inverted Polarity (PB2=1)  
 Input Buffer Enabled (PB1=1)

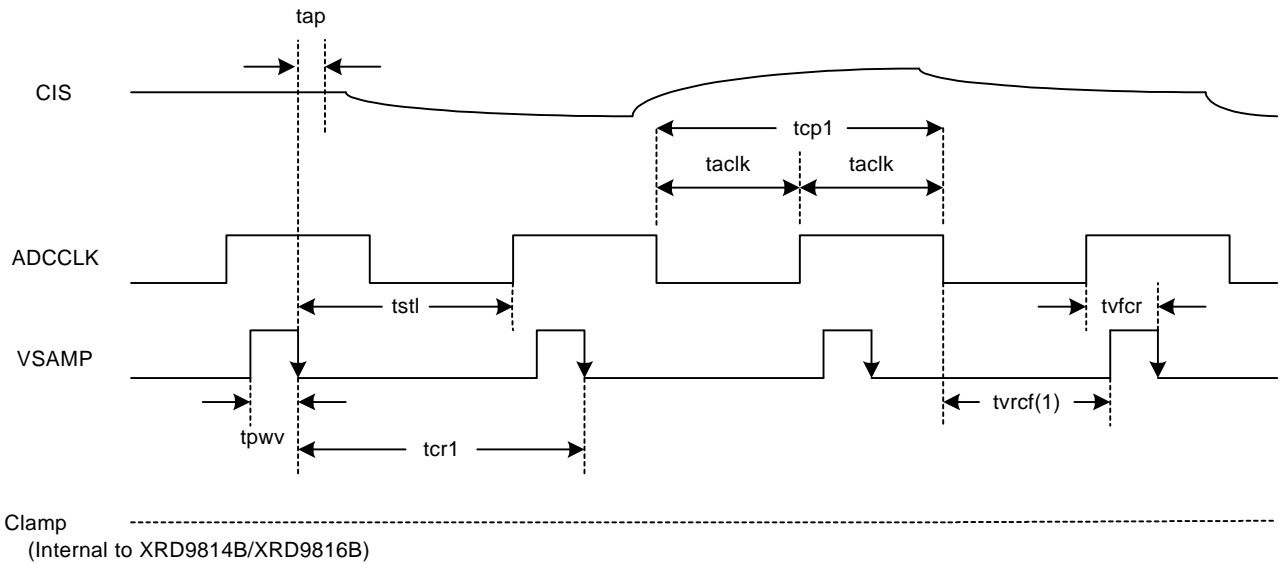

**Notes:** (1) Only VSAMP timing option #1 is supported in 1-channel mode

**Figure 10. 1-Channel S/H Mode - No Clamp (DC Coupled)**

Configuration Register #1: S/H No Clamp (PB7=1, PB6=0)  
 Single Channel (PB4, PB3-RED 01, GRN 10, BLU 11)  
 Non-Inverted Polarity (PB2=1)  
 Input Buffer Disabled (PB1=0)

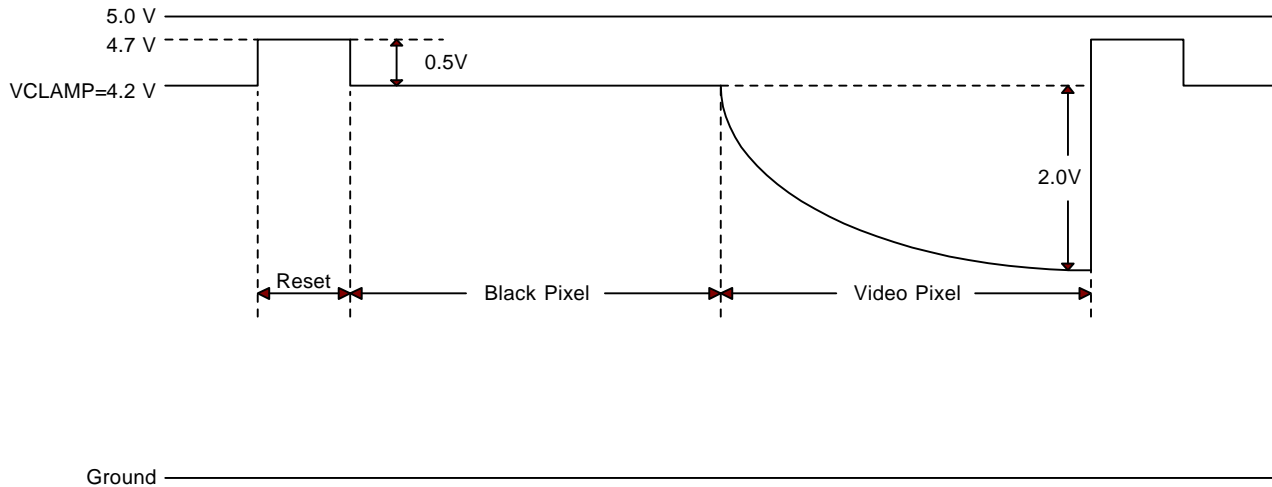

Typical Operation,  $V_{CLAMP} = 4.2V$ , ( $PB4 = 0$ ,  $PB3 = 0$ )  
 $V_{RESET} = 0.5V$ ,  $V_{VIDEO} = 2.0V = FSR$  of XRD9814B/9816B

**Figure 11. VCLAMP Setting Example 1**

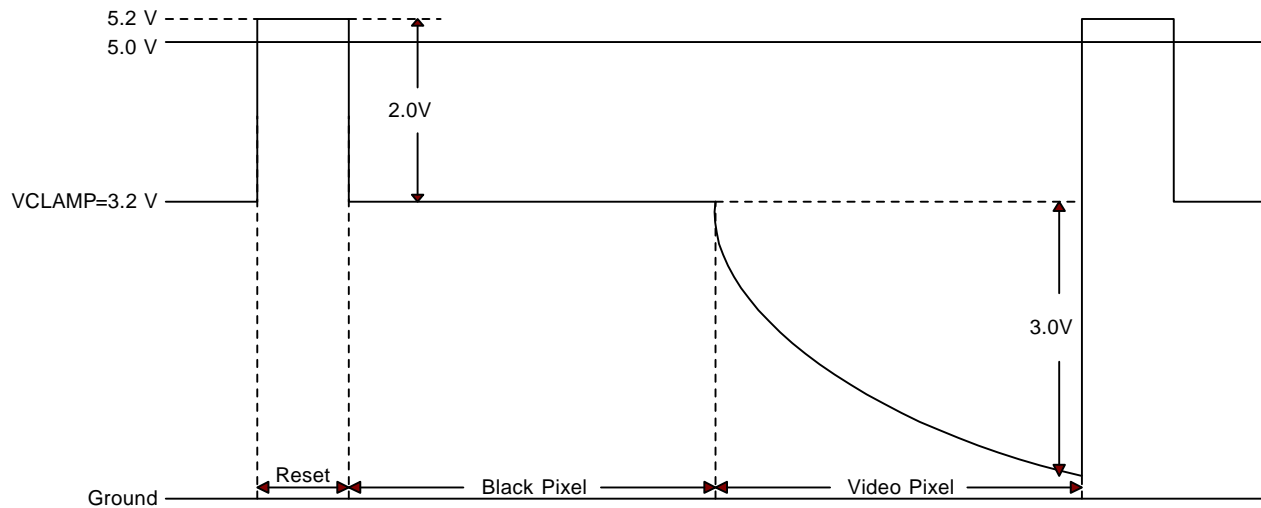

Marginal Operation,  $V_{CLAMP} = 3.2V$ , ( $PB4 = 1$ ,  $PB3 = 0$ )  
 $V_{RESET} = 2.0V$ ,  $V_{VIDEO} = 3.0V = FSR$  of XRD9814B/9816B

**Notes (3) Input signal does not exceed  $V_{DD} + 0.3V$  (Reset)**

**Notes (4) Input signal does not go below 0V (Video pixel)**

**Figure 12. VCLAMP Setting Example 2**

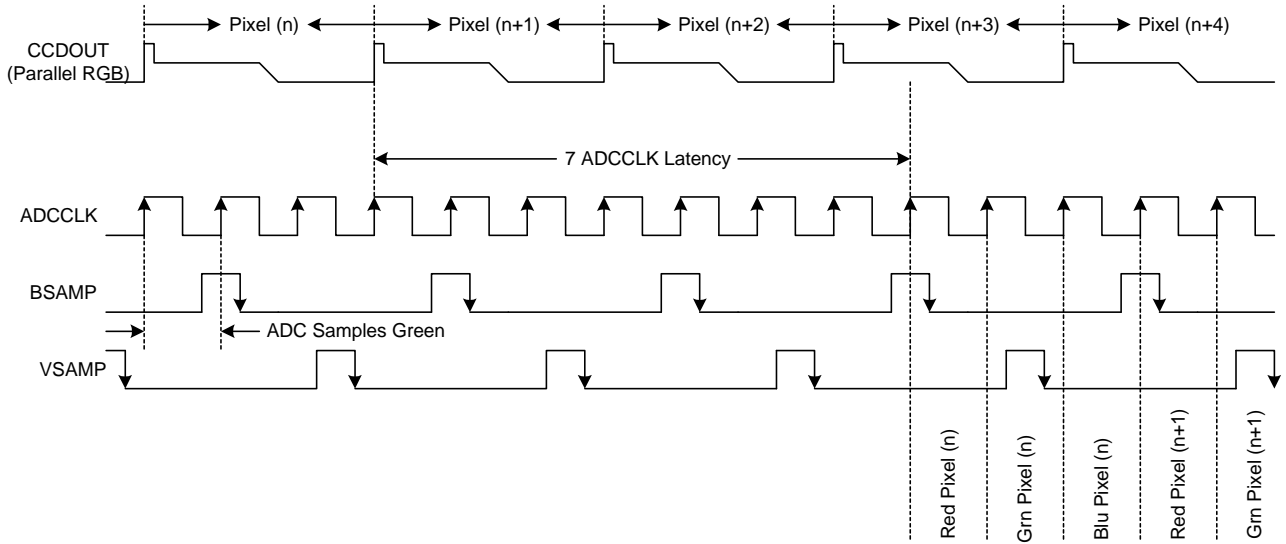

**Figure 13. 3-Channel CDS Pixel Clamp Synchronization and ADC Latency Timing**

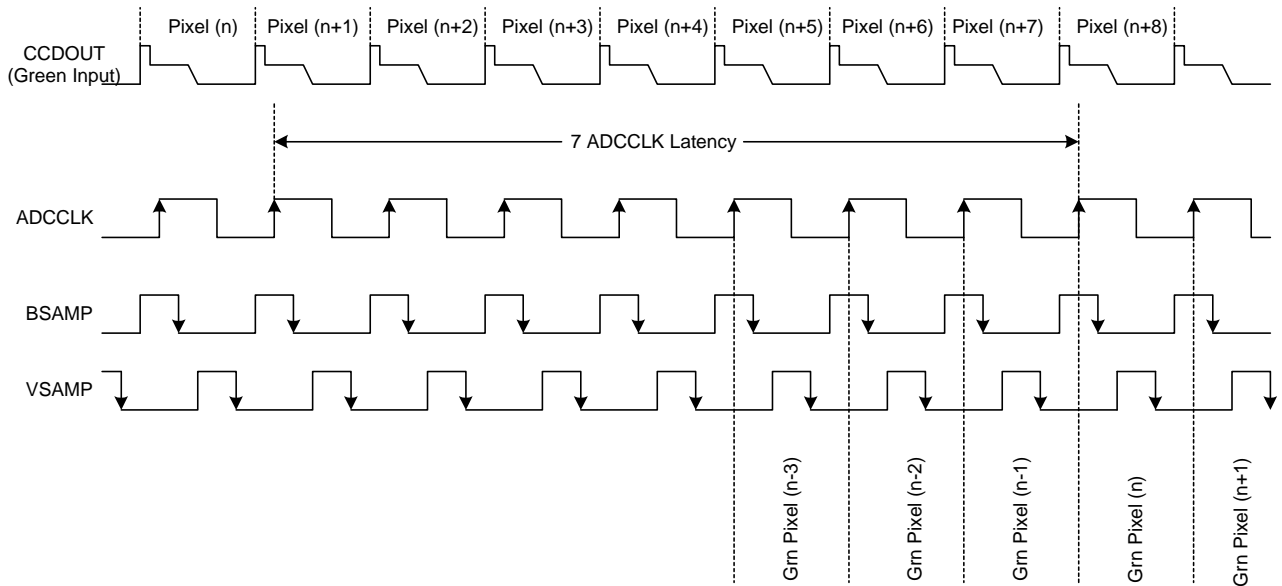

**Figure 14. 1-Channel CDS Pixel Clamp Synchronization and ADC Latency Timing**

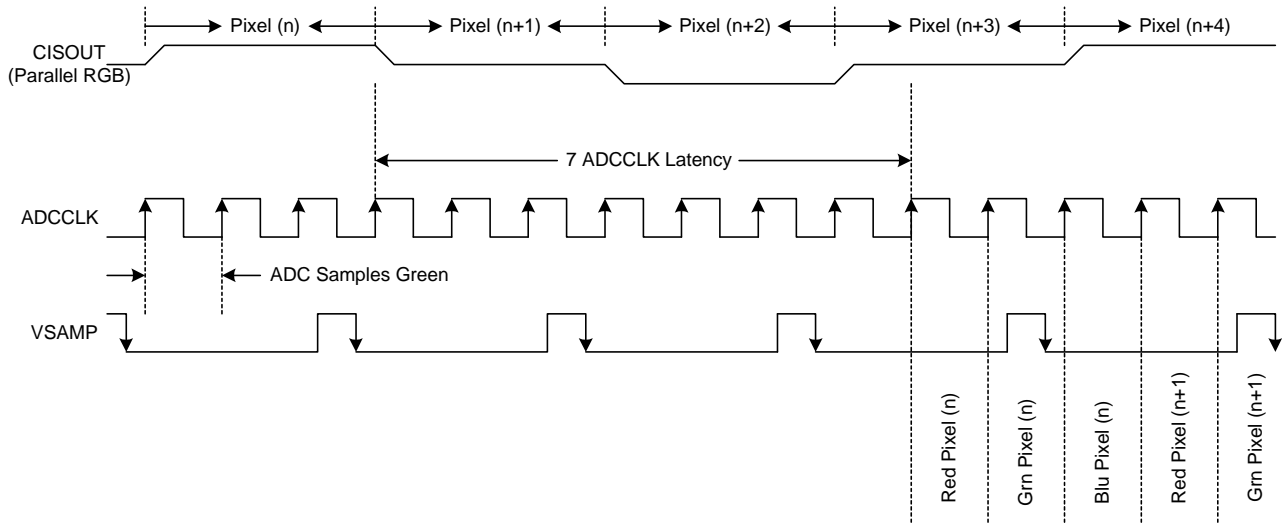

**Figure 15. 3-Channel S/H Synchronization and ADC Latency Timing**

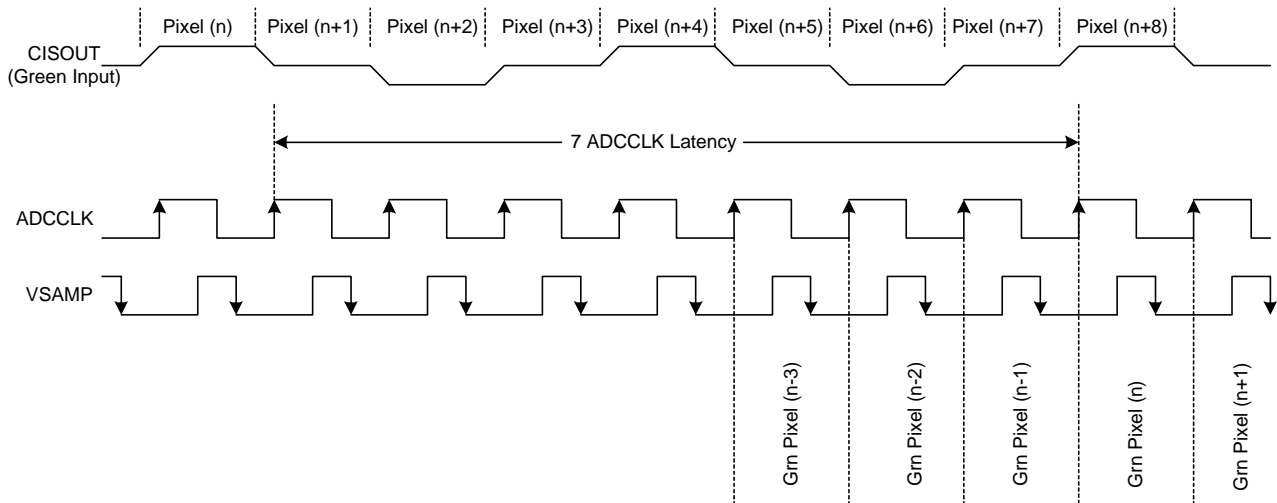

**Figure 16. 1-Channel S/H Synchronization and ADC Latency Timing**

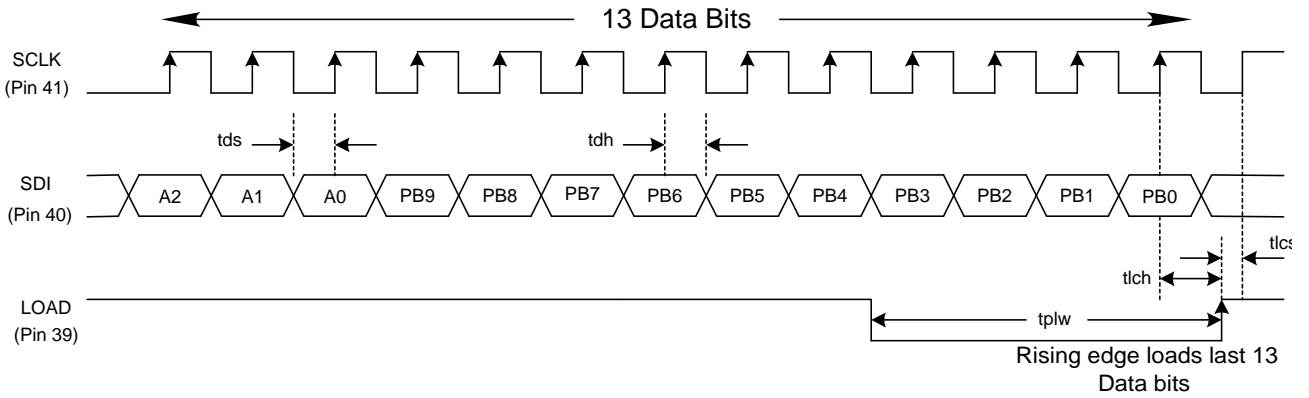

**Figure 17. Write Timing (INSEL = 0)**

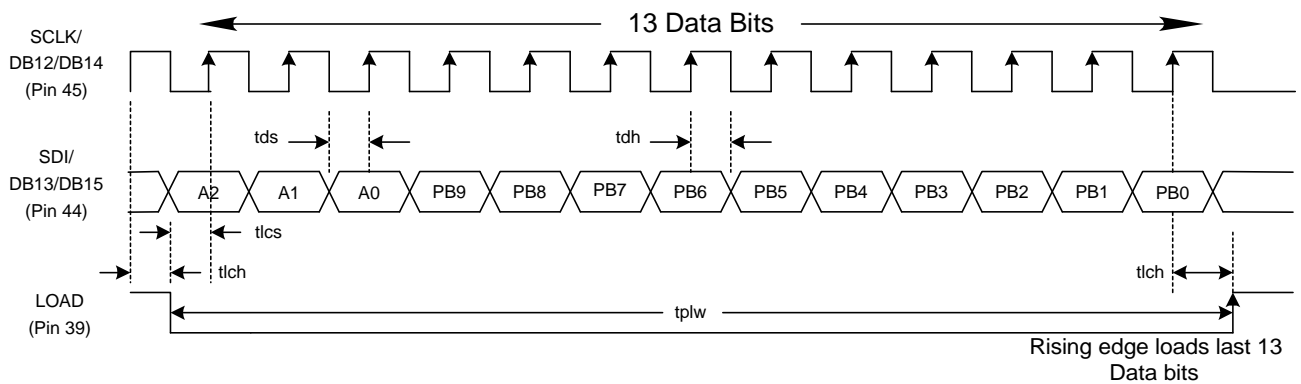

**Figure 18. Write Timing (INSEL = 1)**

## XRD9814B/9816B Read Back Timing

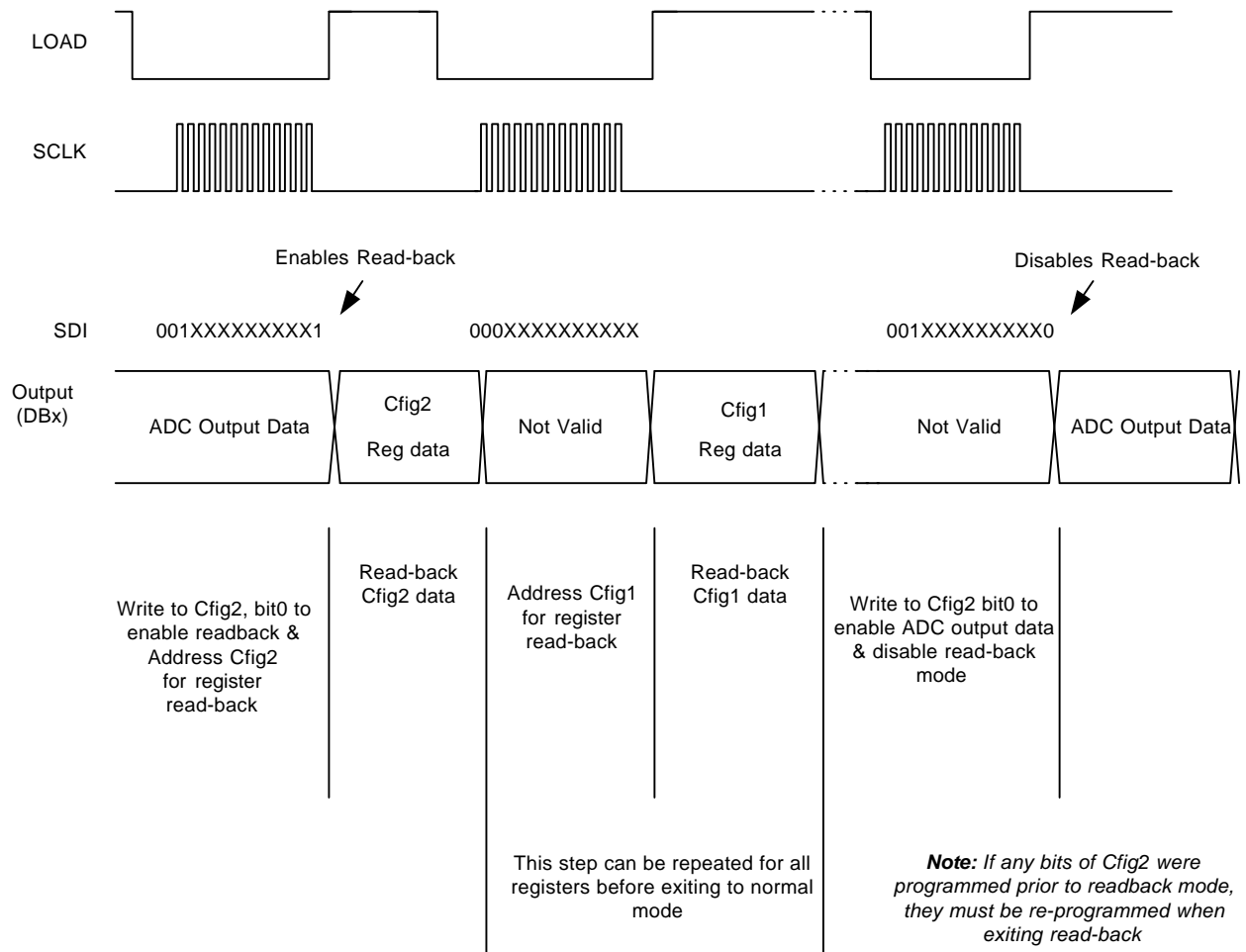
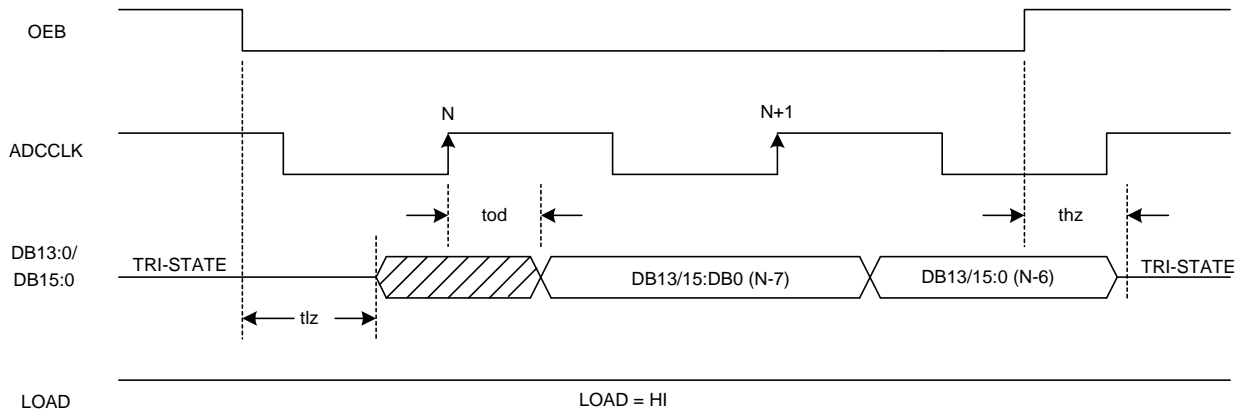
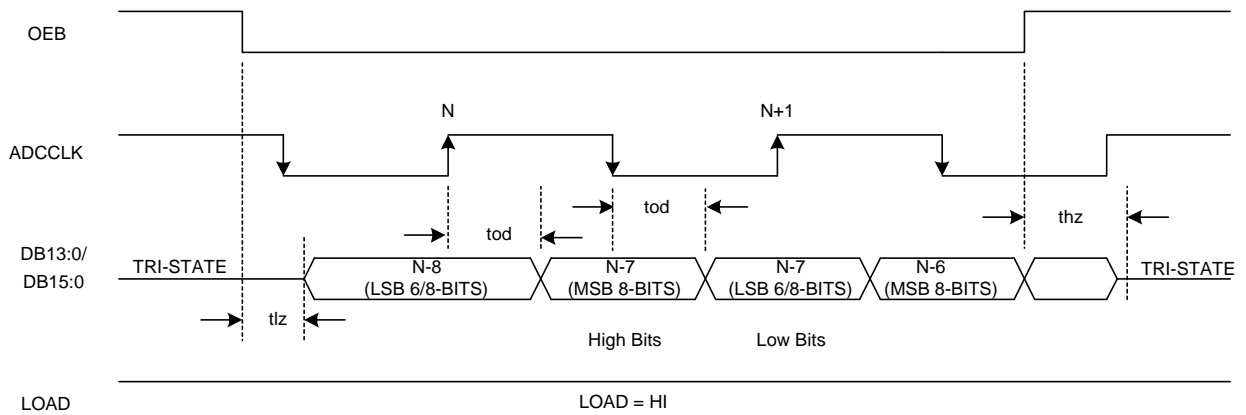

Figure 19. XRD9814B/9816B Read-Back Timing



**Figure 20. ADC Digital Output Timing (OUTSEL = 0)**



**Figure 21. ADC Digital Output Timing (OUTSEL = 1)**

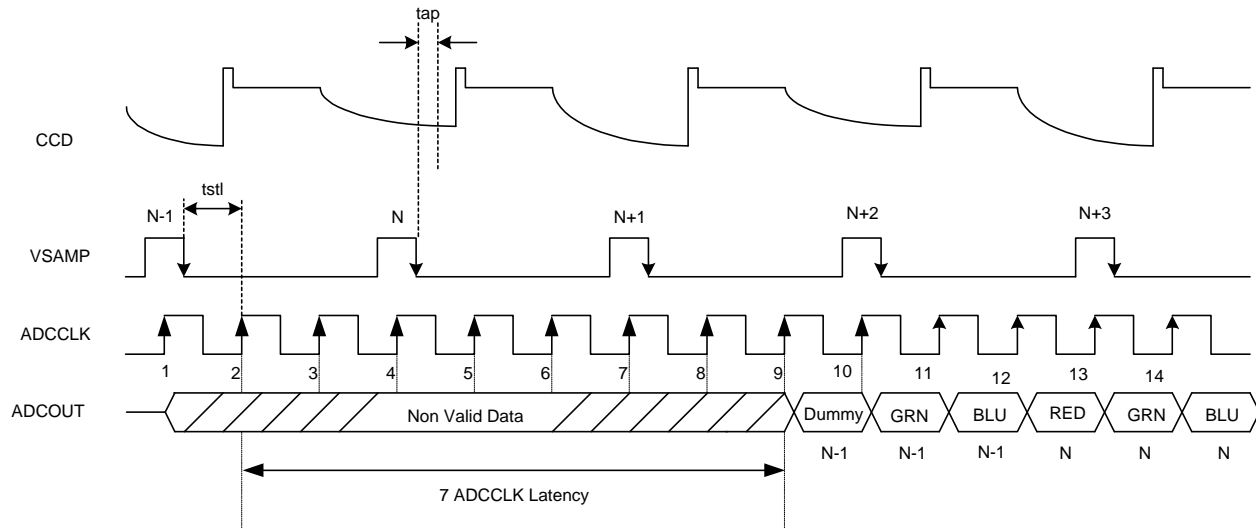

**Figure 22. XRD9814B/XRD9816B Pipeline Latency**

#### ADCCLK/SYNCHRONIZATION EVENTS

- ① Necessary / No Sampling Events Occur
- ② Beginning of Synchronization / Samples Green (N-1) / Converts Unknown Dummy Value
- ③ Samples Blue (N-1) / Converts Green (N-1)
- ④ Samples Red (N) / Converts Blue (N-1)
- ⑤ Synchronization / Samples Green (N) / Converts Red (N)
- ⑥ Samples Blue (N) / Converts Green (N)
- ⑦ Samples Red (N+1) / Converts Blue (N)
- ⑧ Synchronization / Samples Green (N+1) / Converts Red (N+1)
- ⑨ Dummy Pixel (N-1) Valid Generated From ADCCLK #2
- ⑩ GRN Pixel (N-1) Valid Generated From ADCCLK #3
- ⑪ BLU Pixel (N-1) Valid Generated From ADCCLK #4
- ⑫ RED Pixel (N) Valid Generated From ADCCLK #5
- ⑬ GRN Pixel (N) Valid Generated From ADCCLK #6
- ⑭ BLU Pixel (N) Valid Generated From ADCCLK #7

**Note:** Green Channel is Synchronized on the First Rising Edge of ADCCLK After the Falling Edge of VSAMP

## Application Notes

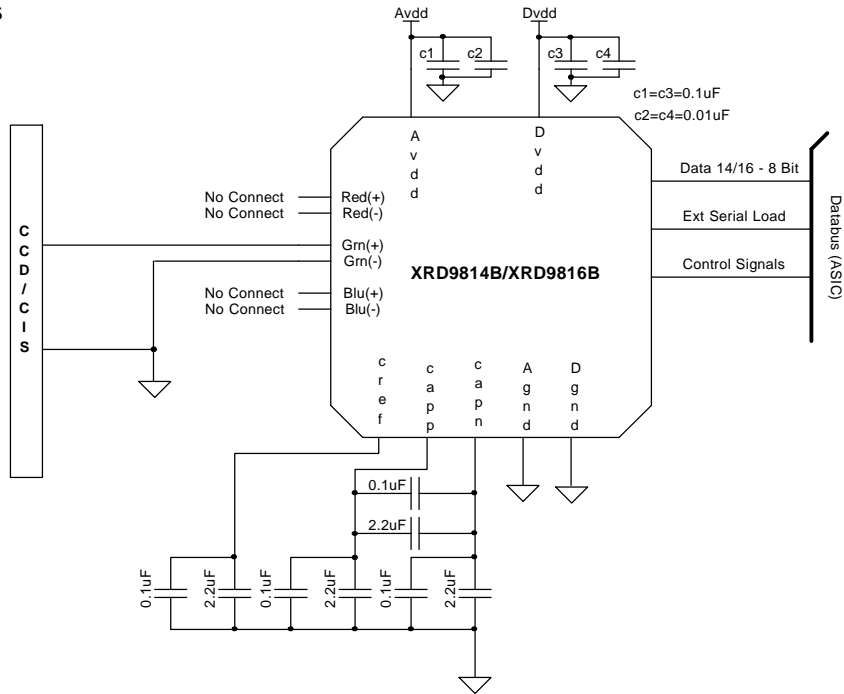

Figure 23. Single Channel DC-Coupled Mode

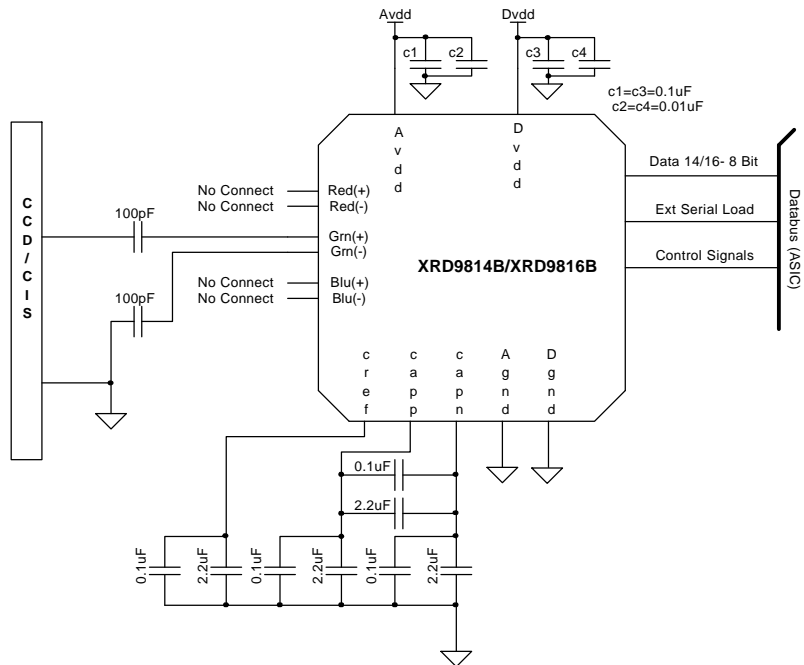

Figure 24. Single Channel AC-Coupled Mode

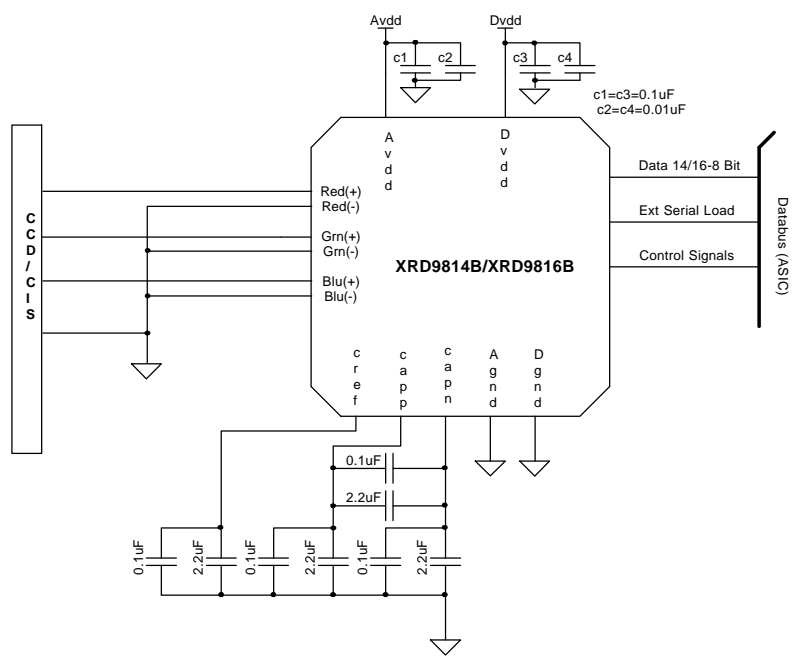

Figure 25. Triple Channel DC-Coupled Mode

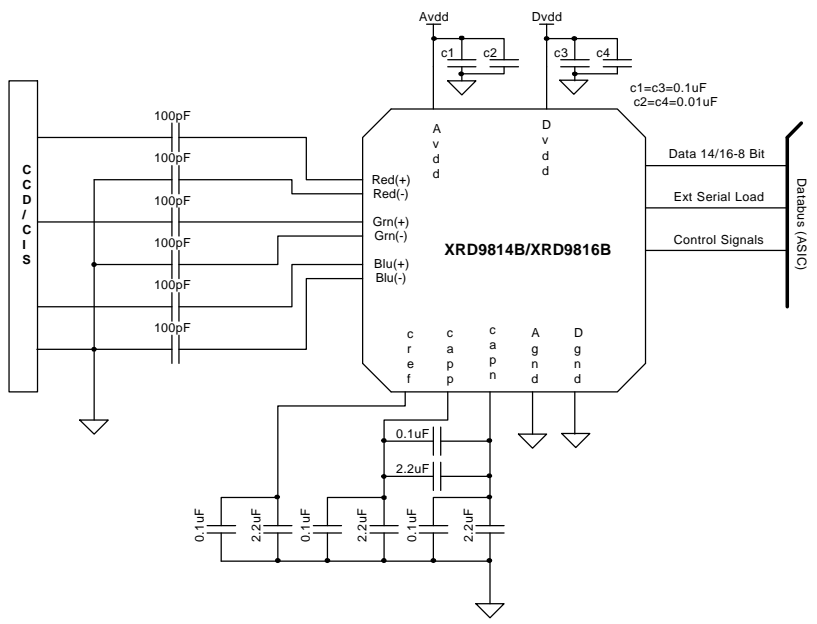
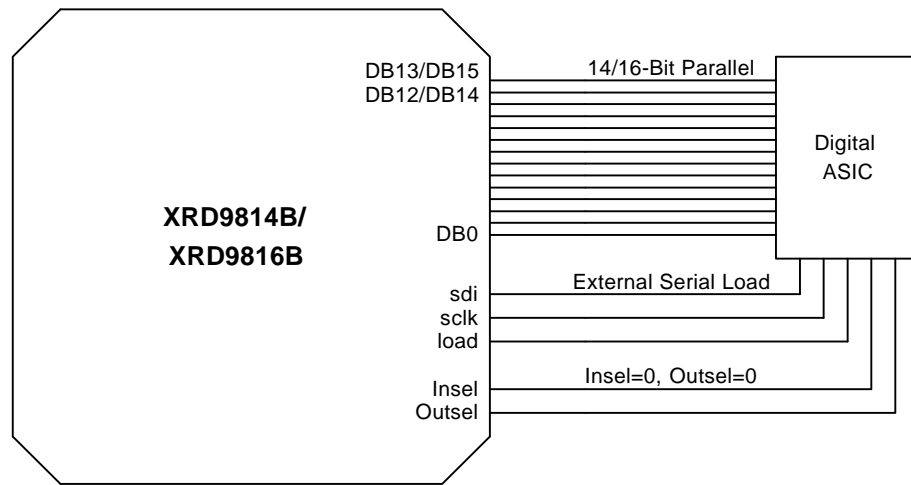

Figure 26. Triple Channel AC-Coupled Mode

**INSEL/OUTSEL Data Output Format**

There are two control signals for setting the output data format and the serial load control. INSEL is used to select the mode for programming the serial port. To use the external pins sdi, sclk and load, INSEL must be low (Figure 17). When INSEL is set to high, DB13/sdi and DB12/sclk become inputs through the bi-directional output bus to load the internal control registers (Figure 18). The load pin is still used to latch the data. This helps to reduce the pin count requirements for the ASIC that drives the XRD9814B/9816B. OUTSEL is used to select the output data format of the

XRD9814B/9816B. The XRD9814B/9816B supports 14/16-bit parallel and 8-bit nibble output modes. When OUTSEL is low, the output bus is standard 14/16-bit parallel (Figure 20). To use the 8-bit nibble output mode, OUTSEL must be set high (Figure 21). In either 14/16-bit or 8-bit nibble applications, the output bus is tri-stated when the bi-directional serial load signal is pulled low.



**Figure 27. 14/16-Bit Output (OUTSEL=0), External Serial Load (INSEL=0)**

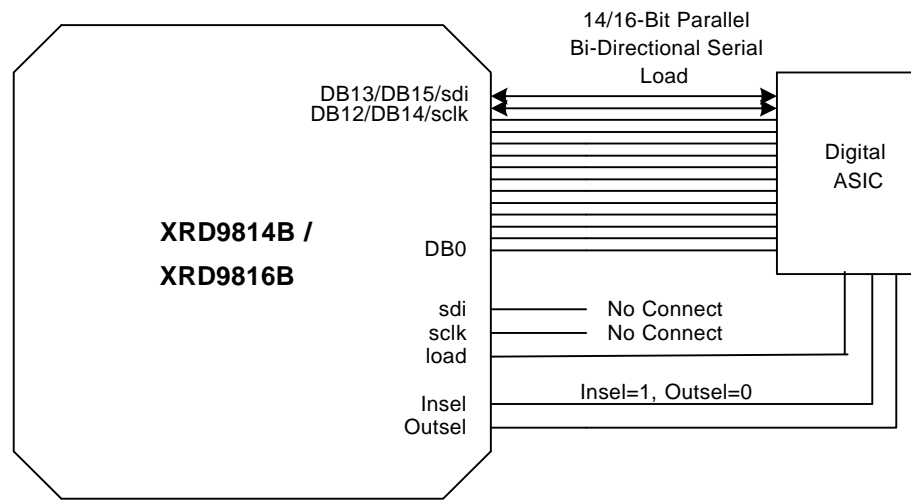

**Figure 28. 14/16-Bit Output (OUTSEL=0), Bi-Directional Serial Load (INSEL=1)**

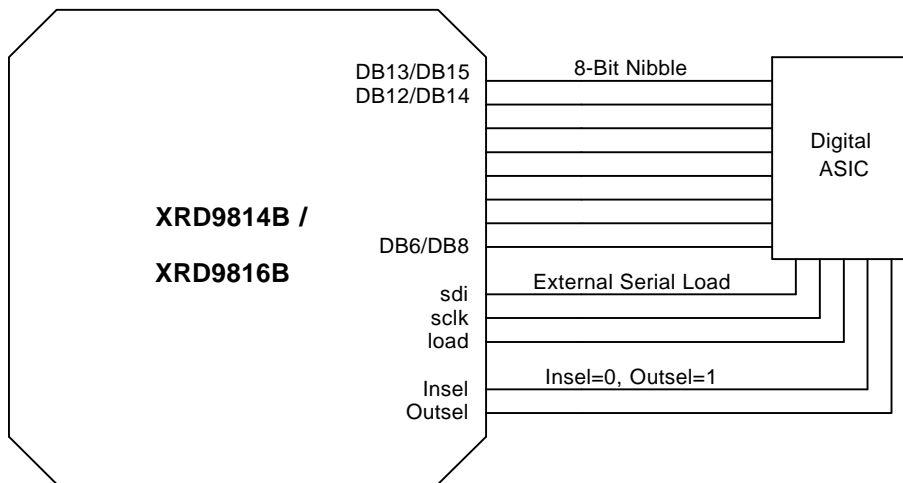

Figure 29. 8-Bit Nibble Output (OUTSEL=1), External Serial Load (INSEL=0)

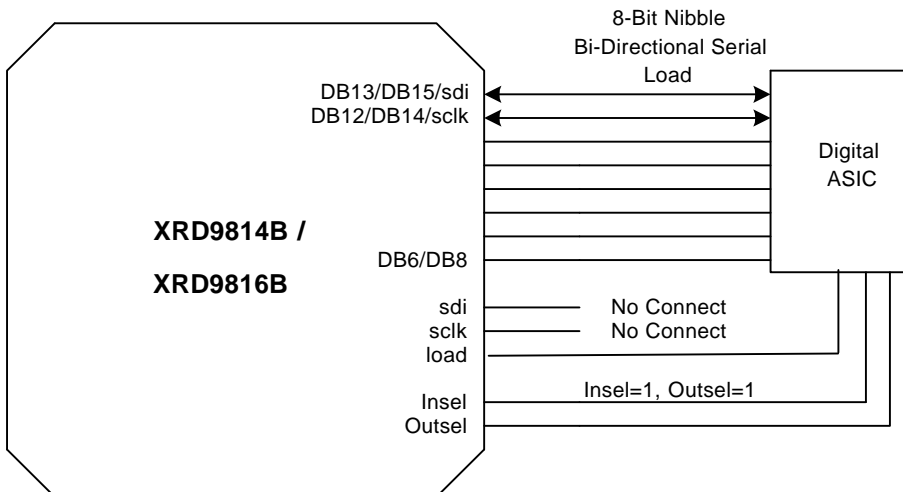
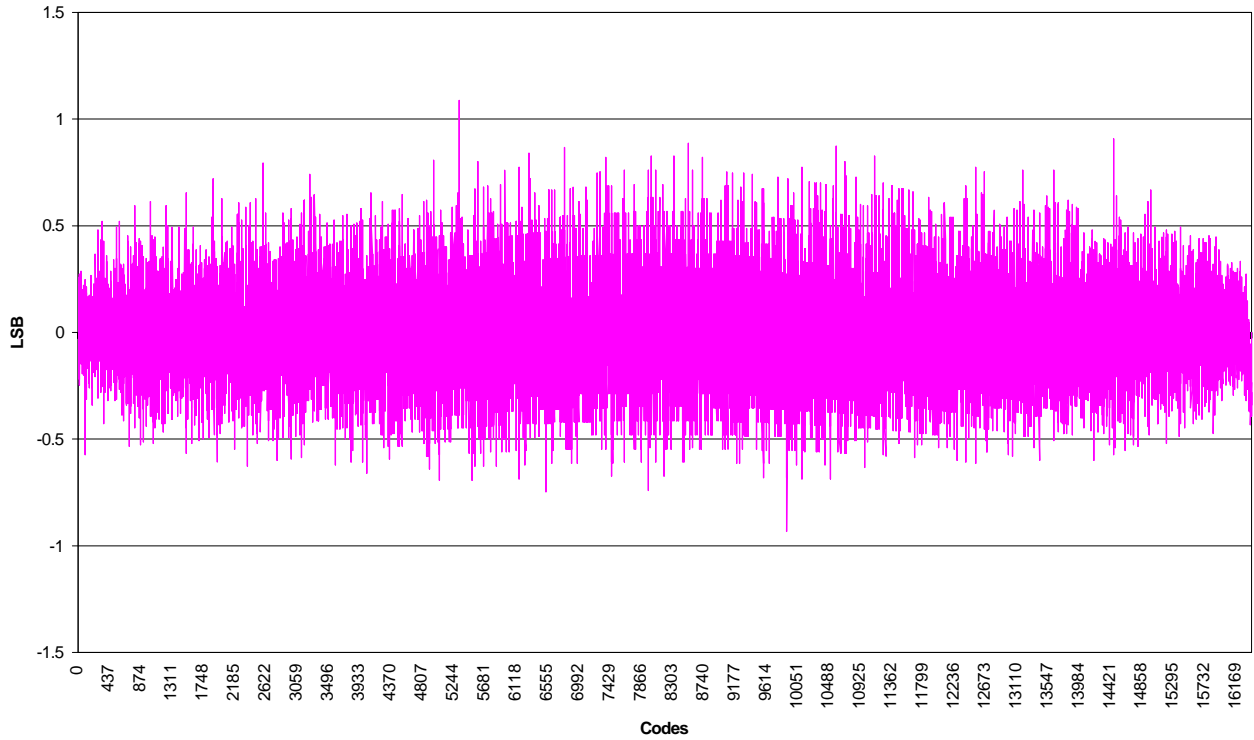

Figure 30. 8-Bit Nibble Output (OUTSEL=1), Bi-Directional Serial Load (INSEL=1)

XRD9814B 1 Channel CIS No Clamp, AVDD = DVDD = 5V, Fs = 6MSPS, 2V Reference  
DNL PLOT



Graph 1. XRD9814B 1-Channel CIS S/H No Clamp DNL Plot

XRD9814B 1-Channel CDS Pixel Clamp, AVDD = DVDD = 5V, Fs = 6MSPS, 2V Reference, DNL Plot

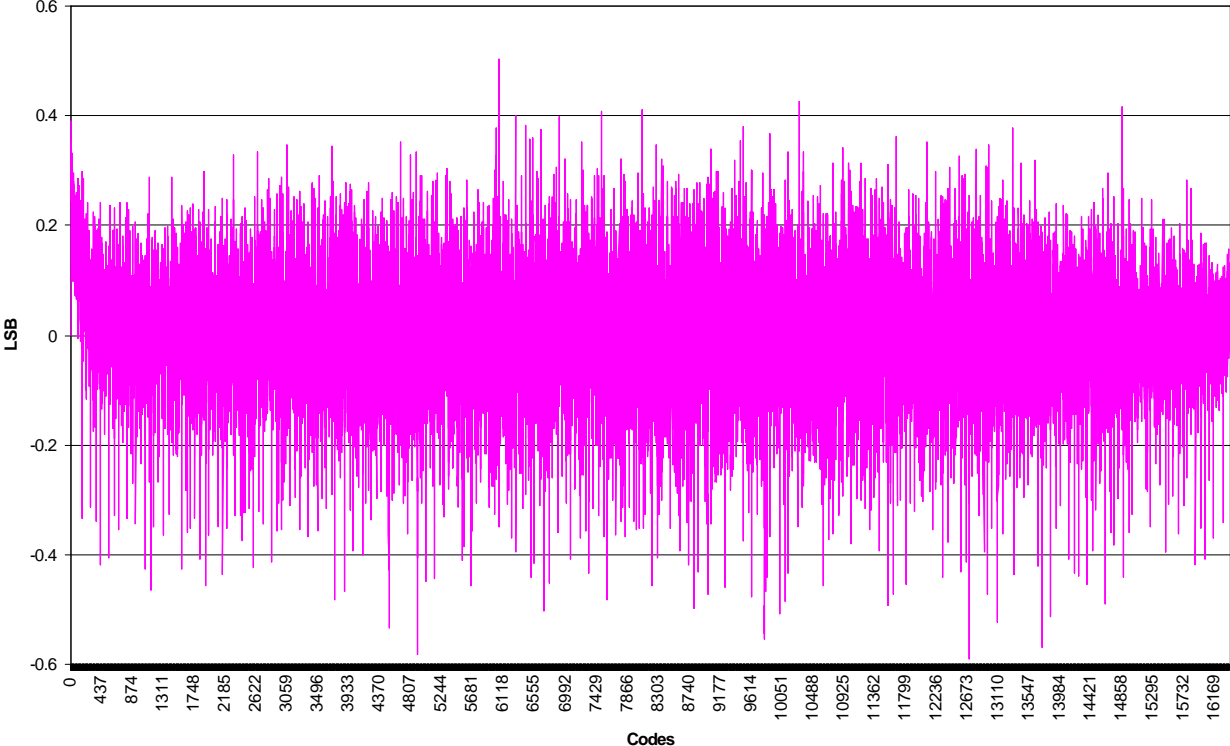

Graph 2. XRD9814B 1-Channel CDS Pixel Clamp DNL Plot

XRD9814B 3-Channel CDS Pixel Clamp, AVDD = DVDD = 5V, Fs = 6MSPS, 2V Reference, DNL Plot

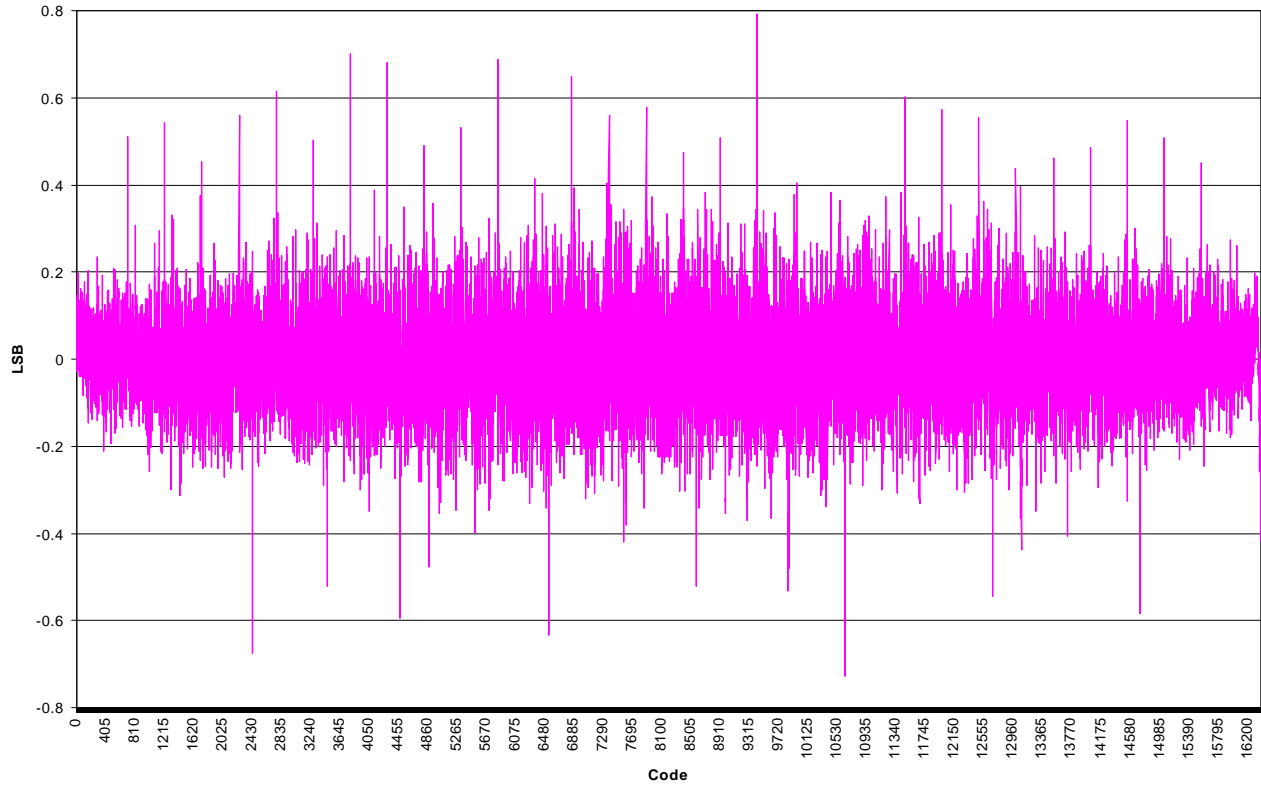

**Graph 3. XRD9814B 3-Channel CDS Pixel Clamp DNL Plot**

XRD9814B 1CH DC CIS Input Referred Noise vs. Gain of 1.63 to 5 V/V  
ADCCLK = 1MSPS, ADC Input Range = 3Vpp, AVDD = 5V, DVDD = 3V

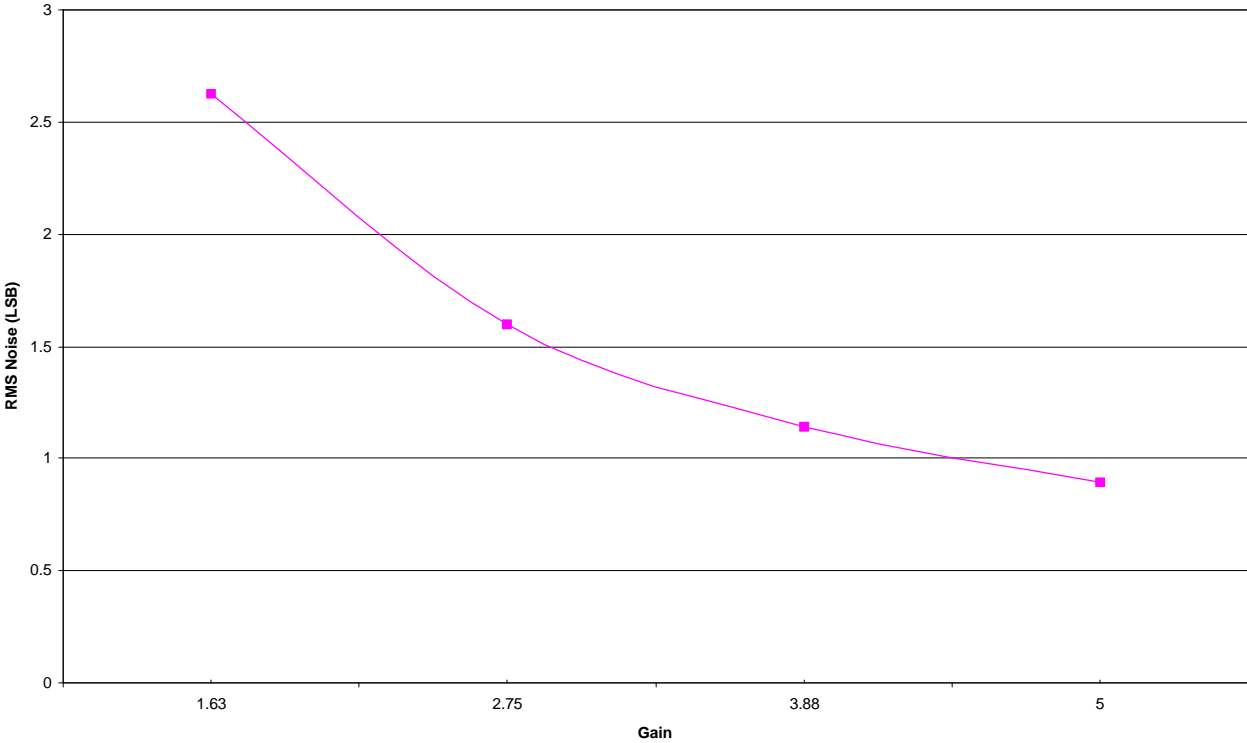

Graph 4. XRD9814B 1-Channel CIS S/H No Clamp Input Referred Noise vs. Gain (1 MSPS)

XRD9814B 1CH DC CIS Input Referred Noise vs. Gain of 1.63 to 5 V/V  
ADCCLK = 6MSPS, ADC Input Range = 3Vpp, AVDD = 5V, DVDD = 3V

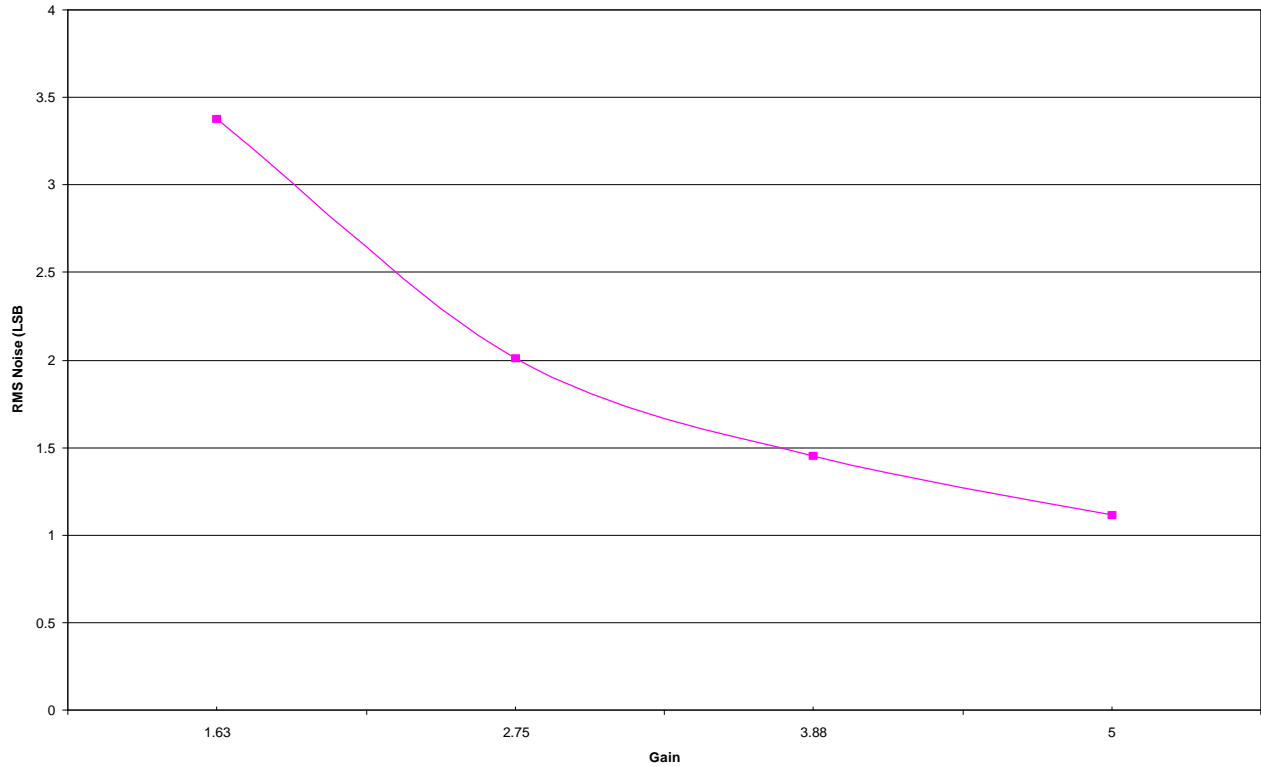

**Graph 5. XRD9814B 1-Channel CIS S/H No Clamp Input Referred Noise vs. Gain (6 MSPS)**

XRD9814B 3CH CDS Input Referred Noise vs. Gain of 1.63 to 5 V/V ADCCLK = 6MSPS,  
AVDD = 5V, DVDD = 3V, ADC Input Range = 3Vpp

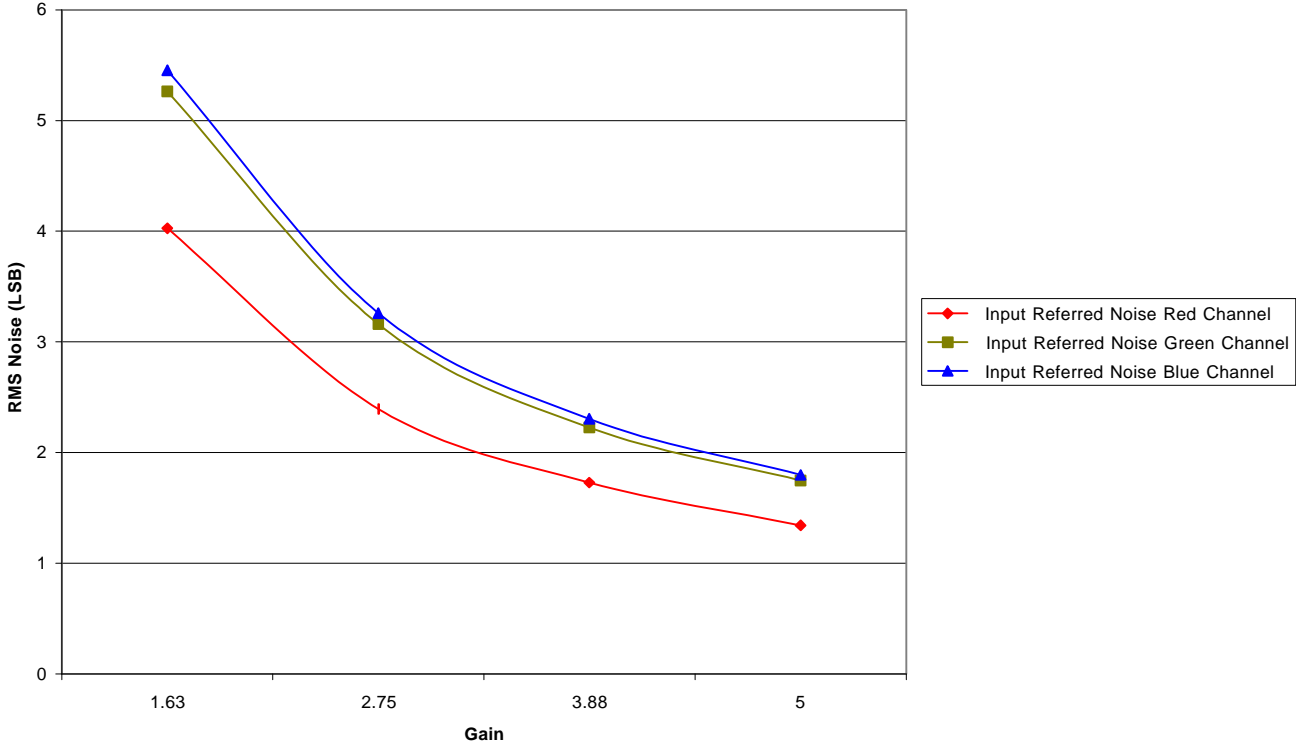

Graph 6. XRD9814B 3-Channel CDS Pixel Clamp Input Referred Noise vs. Gain

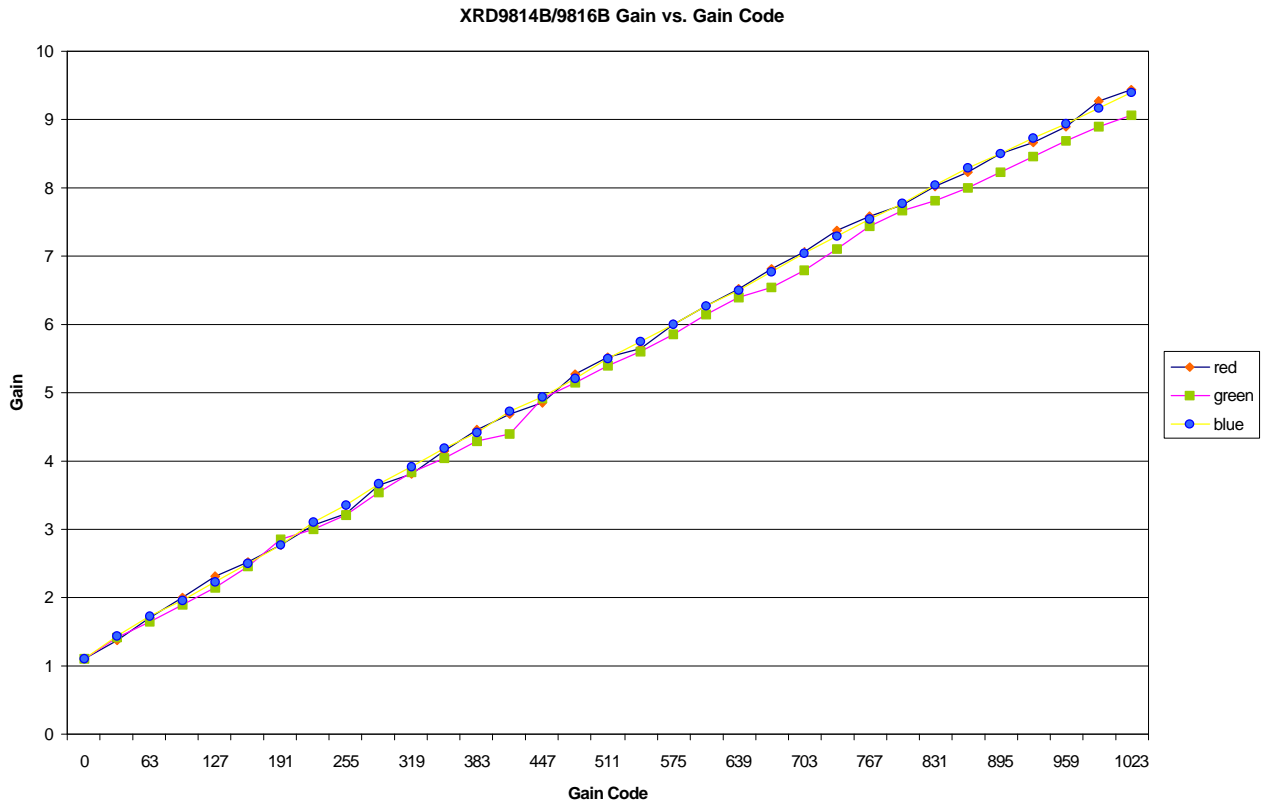

**Graph 7. XRD9814B/9816B Gain vs. Gain Code**

XRD9814B/9816B 3CH CDS, AVDD = 5V, DVDD = 3V, Fs = 6MSPS, 3Vpp, Gain = 0.5 - 5 V/V  
Output Referred System Offset Vs. Gain  
Inputs AC Coupled to Ground with 100pF Capacitors

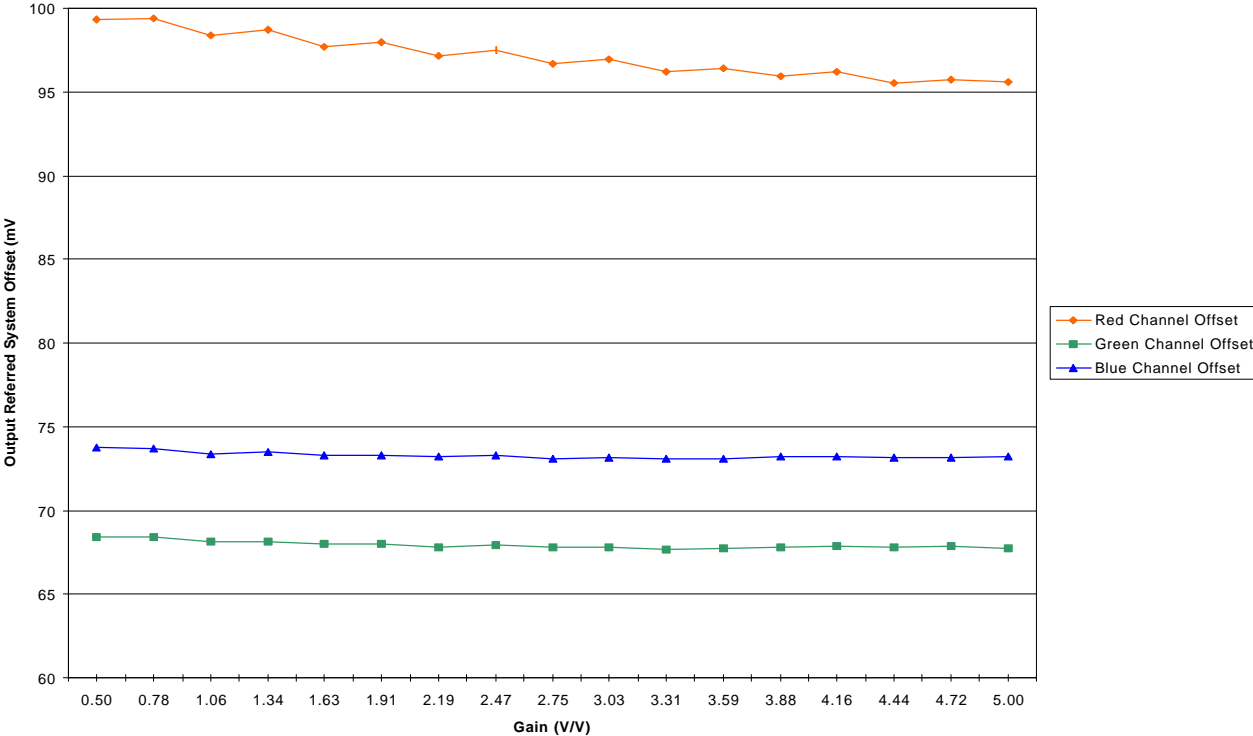

Graph 8. XRD9814B /9816B 3-Channel CDS Pixel Clamp System Offset vs. Gain

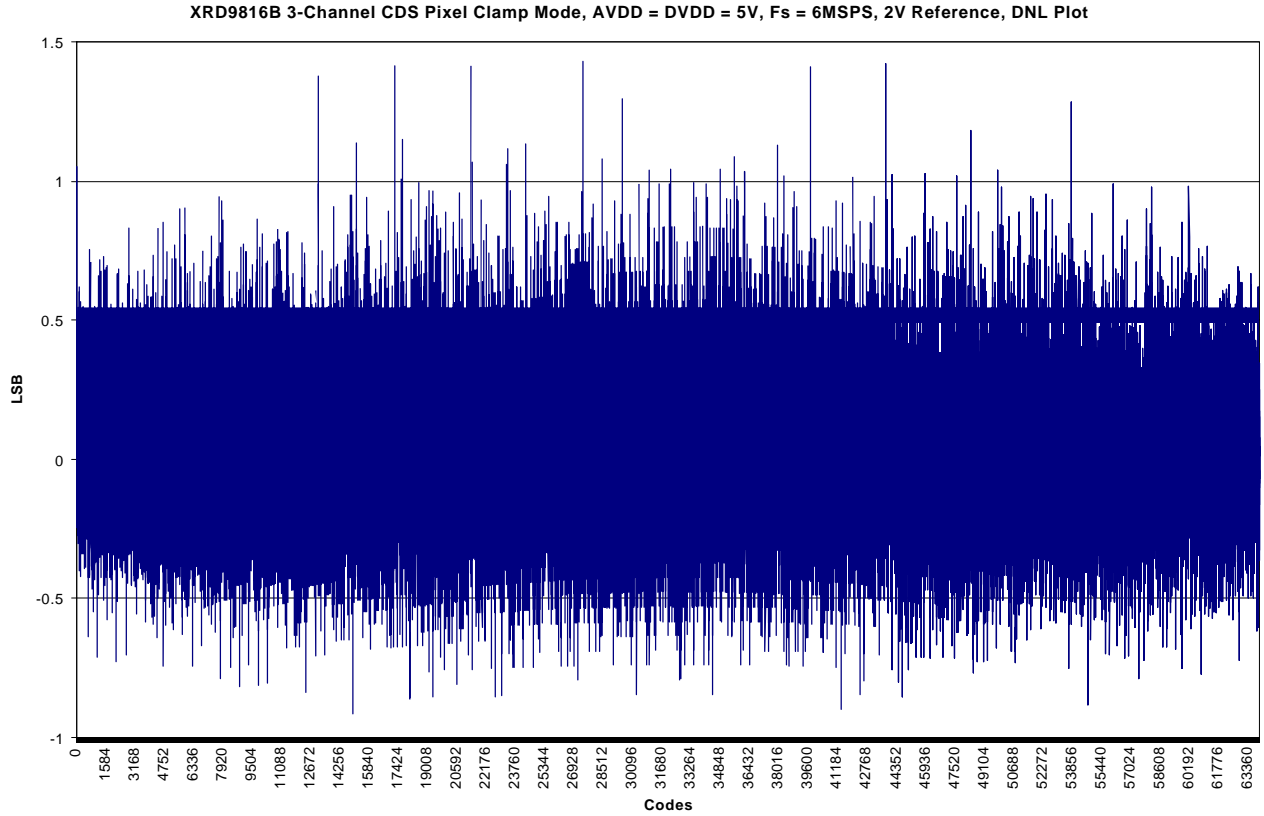

**Graph 9. XRD9816B 3-Channel CDS Pixel Clamp DNL Plot**

XRD9816B 1CH DC CIS Input Referred Noise vs. Gain of 1.63 to 5 V/V  
ADCCLK = 1MSPS, ADC Input Range = 3Vpp, AVDD = 5V, DVDD = 3V

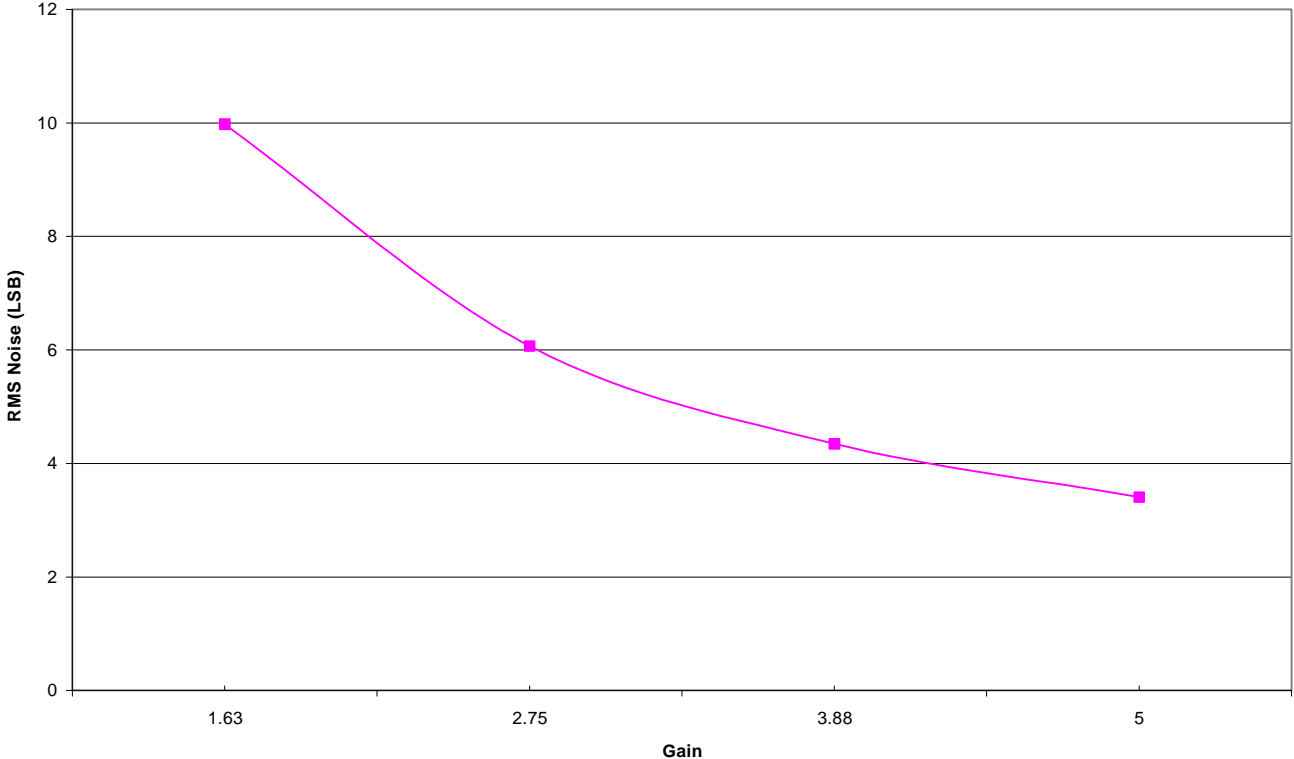

Graph 10. XRD9816B 1-Channel CIS SS/H No Clamp Input Referred Noise vs. Gain (1 MSPS)

XRD9816B 1CH DC CIS Input Referred Noise vs. Gain of 1.63 to 5 V/V  
ADCCLK = 6MSPS, ADC Input Range = 3Vpp, AVDD = 5V, DVDD = 3V

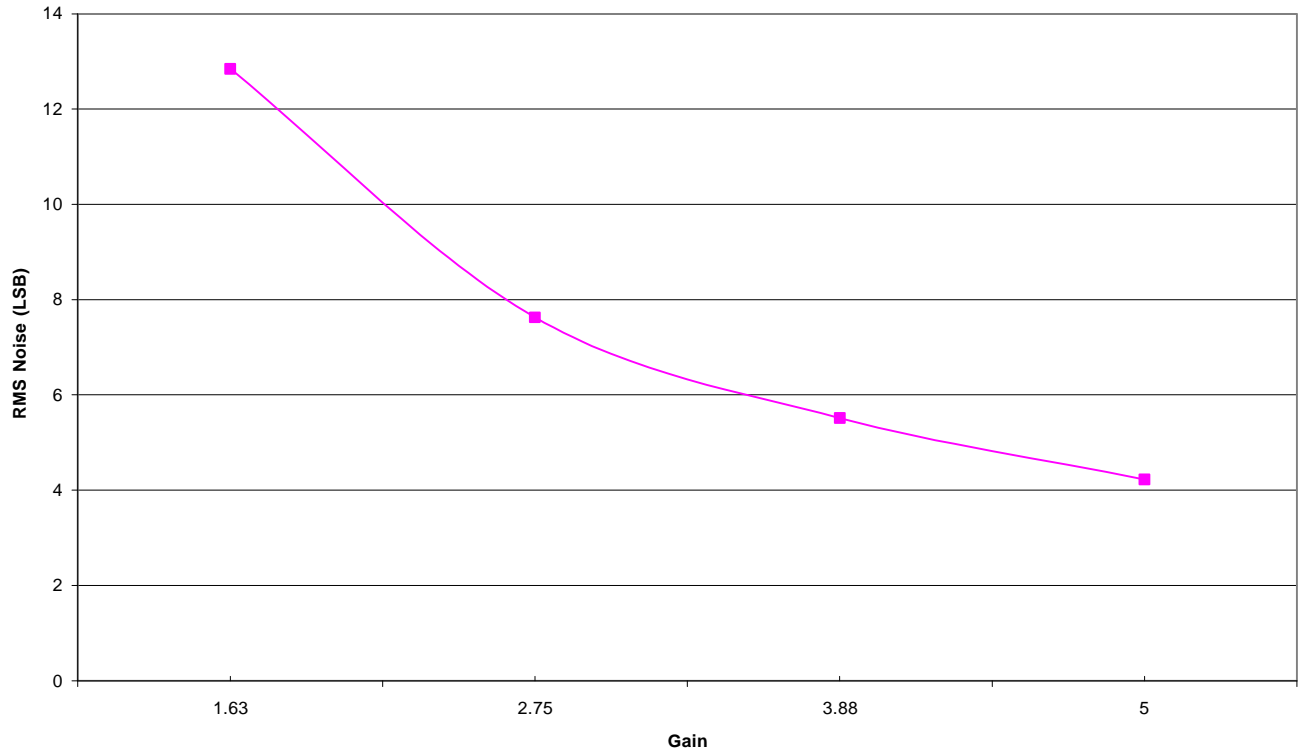

Graph 11. XRD9816B 1-Channel CIS SS/H No Clamp Input Referred Noise vs. Gain (6 MSPS)

## 48 LEAD THIN QUAD FLAT PACK (7 x 7 x 1.4 mm, TQFP)

Rev. 2.00

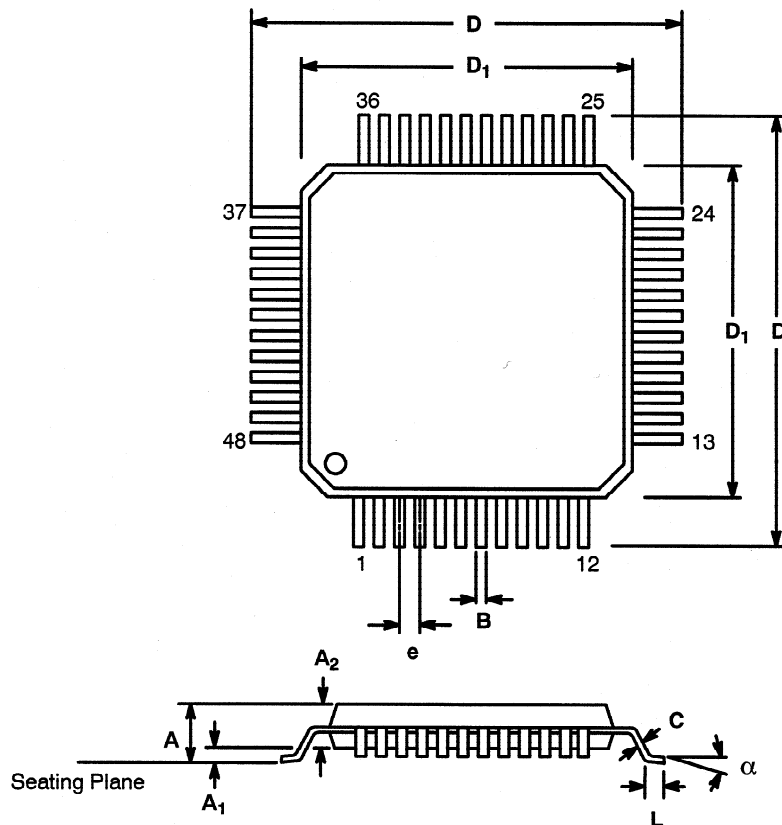

SYMBOL	INCHES		MILLIMETERS	
	MIN	MAX	MIN	MAX
A	0.055	0.063	1.40	1.60
A <sub>1</sub>	0.002	0.006	0.05	0.15
A <sub>2</sub>	0.053	0.057	1.35	1.45
B	0.007	0.011	0.17	0.27
C	0.004	0.008	0.09	0.20
D	0.346	0.362	8.80	9.20
D <sub>1</sub>	0.272	0.280	6.90	7.10
e	0.020 BSC		0.50 BSC	
L	0.018	0.030	0.45	0.75
$\alpha$	0°	7°	0°	7°

Note: The control dimension is the millimeter column

#### NOTICE

EXAR Corporation reserves the right to make changes to the products contained in this publication in order to improve design, performance or reliability. EXAR Corporation assumes no responsibility for the use of any circuits described herein, conveys no license under any patent or other right, and makes no representation that the circuits are free of patent infringement. Charts and schedules contained here in are only for illustration purposes and may vary depending upon a user's specific application. While the information in this publication has been carefully checked; no responsibility, however, is assumed for inaccuracies.

EXAR Corporation does not recommend the use of any of its products in life support applications where the failure or malfunction of the product can reasonably be expected to cause failure of the life support system or to significantly affect its safety or effectiveness. Products are not authorized for use in such applications unless EXAR Corporation receives, in writing, assurances to its satisfaction that: (a) the risk of injury or damage has been minimized; (b) the user assumes all such risks; (c) potential liability of EXAR Corporation is adequately protected under the circumstances.

Copyright 2002 EXAR Corporation

Datasheet November 2002

Reproduction, in part or whole, without the prior written consent of EXAR Corporation is prohibited.

## Looking for pricing, stock, or lifecycle information?

Click below to explore more details on WIN SOURCE:

 [View XRD9816BCV-F on WIN SOURCE](#)

 [Exar Corporation](#) Information

## Optimize Your Supply Chain with WIN SOURCE Solutions

-  Global Sourcing Solution
-  Obsolete Management
-  Cost Control Management
-  Shortage Management
-  Alternative Solution
-  Excess Inventory Management