



**THE DATASHEET OF
TPS65145RGER**



TPS6514x Triple Output LCD Supply With Linear Regulator and Power Good

1 Features

- 2.7-V to 5.8-V Input Voltage Range
- 1.6-MHz Fixed Switching Frequency
- 3 Independent Adjustable Outputs
- Main Output up to 15 V With <1% Typical Output Voltage Accuracy
- Virtual Synchronous Converter Technology
- Negative Regulated Charge Pump Driver V_{O2}
- Positive Charge Pump Converter V_{O3}
- Auxiliary 3.3-V Linear Regulator Controller
- Internal Soft Start
- Internal Power-On Sequencing
- Fault Detection of All Outputs (TPS65140 and TPS65145)
- No Fault Detection (TPS65141)
- Thermal Shutdown
- System Power Good
- Available in 24-Pin HTSSOP and 24-Pin VQFN PowerPAD™ Packages

2 Applications

- TFT LCD Displays for Notebooks
- TFT LCD Displays for Monitors
- Portable DVD Players
- Tablet PCs
- Car Navigation Systems
- Industrial Displays

3 Description

The TPS6514x series offers a compact and small power supply solution to provide all three voltages required by thin film transistor (TFT) LCD displays. The auxiliary linear regulator controller can be used to generate a 3.3-V logic power rail for systems powered by a 5-V supply rail only.

The main output V_{O1} is a 1.6-MHz fixed frequency PWM boost converter providing the source drive voltage for the LCD display. The device is available in two versions with different internal switch current limits to allow the use of a smaller external inductor when lower output power is required. The TPS65140 and TPS65141 has a typical switch current limit of 2.3 A and the TPS65145 has a typical switch current limit of 1.37 A. A fully integrated adjustable charge pump doubler or tripler provides the positive LCD gate drive voltage. An externally adjustable negative charge pump provides the negative gate drive voltage. Due to the high 1.6-MHz switching frequency of the charge pumps, inexpensive and small 220-nF capacitors can be used.

Additionally, the TPS6514x series has a system power good output to indicate when all supply rails are acceptable. For LCD panels powered by 5 V the device has a linear regulator controller using an external transistor to provide a regulated 3.3-V output for the digital circuits. For maximum safety, the TPS65140 and TPS65145 goes into shutdown as soon as one of the outputs is out of regulation. The device can be enabled again by toggling the input or the enable (EN) pin to GND. The TPS65141 does not enter shutdown when one of its outputs is below its power good threshold.

Block Diagram

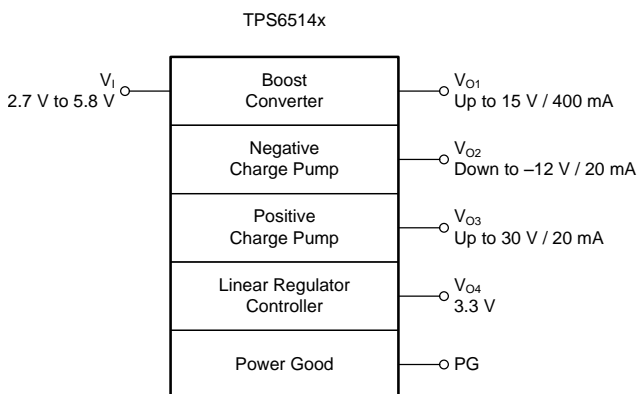

Copyright © 2016, Texas Instruments Incorporated

Device Information⁽¹⁾

PART NUMBER	PACKAGE	BODY SIZE (NOM)
TPS6514x	HTSSOP (24)	7.80 mm x 4.40 mm
	VQFN (24)	4.00 mm x 4.00 mm

(1) For all available packages, see the orderable addendum at the end of the data sheet.



Table of Contents

1 Features	1	8.1 Application Information.....	12
2 Applications	1	8.2 Typical Application	12
3 Description	1	8.3 System Examples	21
4 Revision History	2	9 Power Supply Recommendations	22
5 Pin Configuration and Functions	3	10 Layout	23
6 Specifications	4	10.1 Layout Guidelines	23
6.1 Absolute Maximum Ratings	4	10.2 Layout Example	23
6.2 ESD Ratings.....	4	10.3 Thermal Considerations	23
6.3 Recommended Operating Conditions.....	4	11 Device and Documentation Support	24
6.4 Thermal Information	5	11.1 Device Support.....	24
6.5 Electrical Characteristics.....	5	11.2 Documentation Support	24
6.6 Dissipation Ratings	7	11.3 Related Links	24
6.7 Typical Characteristics	7	11.4 Receiving Notification of Documentation Updates	24
7 Detailed Description	8	11.5 Community Resources.....	24
7.1 Overview	8	11.6 Trademarks	24
7.2 Functional Block Diagram	9	11.7 Electrostatic Discharge Caution.....	24
7.3 Feature Description.....	10	11.8 Glossary	25
7.4 Device Functional Modes.....	11	12 Mechanical, Packaging, and Orderable	25
8 Application and Implementation	12	Information	25

4 Revision History

NOTE: Page numbers for previous revisions may differ from page numbers in the current version.

Changes from Revision E (November 2012) to Revision F	Page
• Added <i>ESD Ratings</i> table, <i>Thermal Information</i> table, <i>Feature Description</i> section, <i>Device Functional Modes</i> section, <i>Application and Implementation</i> section, <i>Power Supply Recommendations</i> section, <i>Layout</i> section, <i>Device and Documentation Support</i> section, and <i>Mechanical, Packaging, and Orderable Information</i> section	1
• Deleted <i>Ordering Information</i> table; see POA at the end of the data sheet.....	1
• Changed typical value of V_{REF} to 1.213 V from 1.13 V	5
• Moved Figure 12 through Figure 23 from <i>Typical Applications</i> to <i>Application Curves</i>	19

5 Pin Configuration and Functions

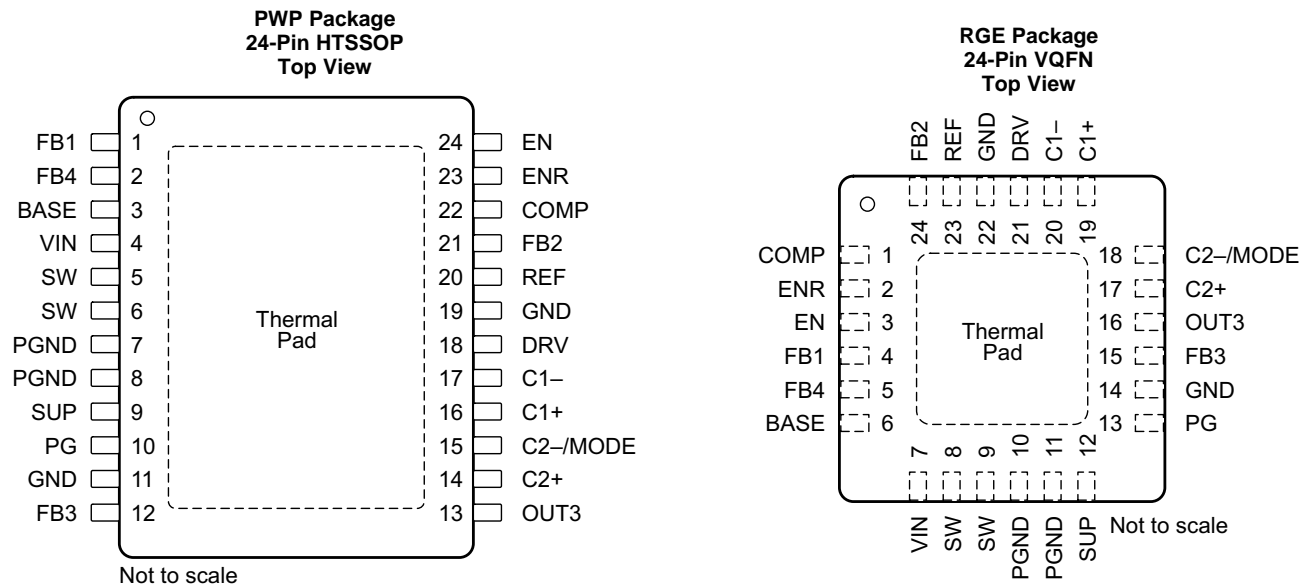

Pin Functions

NAME	PIN NO.		I/O	DESCRIPTION
	HTSSOP	VQFN		
BASE	3	6	O	Base drive output for the external transistor
C1+	16	19	—	Positive terminal of the charge pump flying capacitor
C1-	17	20	—	Negative terminal of the charge pump flying capacitor
C2+	14	17	—	Positive terminal for the charge pump flying capacitor. If the device runs in voltage doubler mode, this pin must be left open.
C2-/MODE	15	18	—	Negative terminal of the charge pump flying capacitor and charge pump MODE pin. If the flying capacitor is connected to this pin, the converter operates in a voltage tripler mode. If the charge pump must operate in a voltage doubler mode, the flying capacitor is removed and the C2-/MODE pin must be connected to GND.
COMP	22	1	—	Compensation pin for the main boost converter. A small capacitor is connected to this pin.
DRV	18	21	O	External charge pump driver
EN	24	3	I	Enable pin of the device. This pin must be terminated and not be left floating. A logic high enables the device and a logic low shuts down the device.
ENR	23	2	I	Enable pin of the linear regulator controller. This pin must be terminated and not be left floating. Logic high enables the regulator and a logic low puts the regulator in shutdown.
FB1	1	4	I	Feedback pin of the boost converter
FB2	21	24	I	Feedback pin of negative charge pump
FB3	12	15	I	Feedback pin of positive charge pump
FB4	2	5	I	Feedback pin of the linear regulator controller. The linear regulator controller is set to a fixed output voltage of 3.3 V or 3 V depending on the version.
GND	11, 19	14, 22	—	Ground
OUT3	13	16	O	Positive charge pump output
PG	10	13	O	Open-drain output indicating when all outputs V_{O1} , V_{O2} , V_{O3} are within 10% of their nominal output voltage. The output goes low when one of the outputs falls below 10% of their nominal output voltage.
PGND	7, 8	10, 11	—	Power ground
PowerPAD / Thermal Die	—	—	—	The PowerPAD or exposed thermal die must be connected to power ground pins (PGND)
REF	20	23	O	Internal reference output typically 1.23 V

Pin Functions (continued)

NAME	PIN		I/O	DESCRIPTION
	NO.			
	HTSSOP	VQFN		
SUP	9	12	I	Supply pin of the positive, negative charge pump, boost converter, and gate drive circuit. This pin must be connected to the output of the main boost converter and cannot be connected to any other voltage source. For performance reasons, TI does not recommend connecting a bypass capacitor directly to this pin.
SW	5, 6	8, 9	I	Switch pin of the boost converter
VIN	4	7	I	Input voltage pin of the device.

6 Specifications

6.1 Absolute Maximum Ratings

over operating free-air temperature range (unless otherwise noted)⁽¹⁾

	MIN	MAX	UNIT
Voltages on pin VIN ⁽²⁾	–0.3	6	V
Voltages on pin V _{O1} , SUP, PG ⁽²⁾	–0.3	15.5	V
Voltages on pin EN, MODE, ENR ⁽²⁾	–0.3	V _I + 0.3	V
Voltage on pin SW ⁽²⁾		20	V
Power good maximum sink current (PG)		1	mA
Continuous power dissipation	See Dissipation Ratings		
Lead temperature (soldering, 10 s)		260	°C
Operating junction temperature, T _J	–40	150	°C
Storage temperature, T _{stg}	–65	150	°C

- (1) Stresses beyond those listed under *Absolute Maximum Ratings* may cause permanent damage to the device. These are stress ratings only, which do not imply functional operation of the device at these or any other conditions beyond those indicated under *Recommended Operating Conditions*. Exposure to absolute-maximum-rated conditions for extended periods may affect device reliability.
- (2) All voltage values are with respect to network ground terminal.

6.2 ESD Ratings

		VALUE	UNIT
V _(ESD)	Electrostatic discharge	Human-body model (HBM), per ANSI/ESDA/JEDEC JS-001 ⁽¹⁾	±2000
		Charged-device model (CDM), per JEDEC specification JESD22-C101 ⁽²⁾	±500

- (1) JEDEC document JEP155 states that 500-V HBM allows safe manufacturing with a standard ESD control process.
- (2) JEDEC document JEP157 states that 250-V CDM allows safe manufacturing with a standard ESD control process.

6.3 Recommended Operating Conditions

		MIN	NOM	MAX	UNIT
V _I	Input voltage	2.7		5.8	V
L	Inductor ⁽¹⁾		4.7		μH
T _A	Operating ambient temperature	–40		85	°C
T _J	Operating junction temperature	–40		125	°C

- (1) See the application information section for further information.

6.4 Thermal Information

THERMAL METRIC ⁽¹⁾	TPS6514x		UNIT	
	PWP (HTSSOP)	RGE (VQFN)		
	24 PINS	24 PINS		
R _{θJA}	Junction-to-ambient thermal resistance	37.2	34.2	°C/W
R _{θJC(top)}	Junction-to-case (top) thermal resistance	18.9	35.5	°C/W
R _{θJB}	Junction-to-board thermal resistance	16.4	11.7	°C/W
ψ _{JT}	Junction-to-top characterization parameter	0.4	0.4	°C/W
ψ _{JB}	Junction-to-board characterization parameter	16.2	11.7	°C/W
R _{θJC(bot)}	Junction-to-case (bottom) thermal resistance	2.1	3.2	°C/W

(1) For more information about traditional and new thermal metrics, see the [Semiconductor and IC Package Thermal Metrics](#) application report.

6.5 Electrical Characteristics

V_I = 3.3 V, EN = VIN, V_{O1} = 10 V, T_A = -40°C to 85°C, typical values are at T_A = 25°C (unless otherwise noted)

PARAMETER	TEST CONDITIONS	MIN	TYP	MAX	UNIT	
SUPPLY CURRENT						
V _I	Input voltage	2.7		5.5	V	
I _Q	Quiescent current into VIN	ENR = GND, V _{O3} = 2 × V _{O1} , Boost converter not switching	0.7	0.9	mA	
I _{QCharge}	Charge pump quiescent current into SUP	V _{O1} = SUP = 10 V, V _{O3} = 2 × V _{O1} V _{O1} = SUP = 10 V, V _{O3} = 3 × V _{O1}	1.7 3.9	2.7 6	mA	
I _{QEN}	LDO controller quiescent current into VIN	ENR = VIN, EN = GND	300	800	μA	
I _{SD}	Shutdown current into VIN	EN = ENR = GND	1	10	μA	
V _{UVLO}	Undervoltage lockout threshold	V _I falling	2.2	2.4	V	
	Thermal shutdown	Temperature rising	160		°C	
LOGIC SIGNALS EN, ENR						
V _{IH}	High level input voltage	1.5			V	
V _{IL}	Low level input voltage			0.4	V	
I _I	Input leakage current	EN = GND or VIN	0.01	0.1	μA	
MAIN BOOST CONVERTER						
V _{O1}	Output voltage	5		15	V	
V _{O1} - VIN	Minimum input to output voltage difference	1			V	
V _{REF}	Reference voltage	1.205	1.213	1.219	V	
V _{FB}	Feedback regulation voltage	1.136	1.146	1.154	V	
I _{FB}	Feedback input bias current		10	100	nA	
r _{DS(on)}	N-MOSFET ON-resistance (Q1)	V _{O1} = 10 V, I _{SW} = 500 mA V _{O1} = 5 V, I _{SW} = 500 mA	195 285	290 420	mΩ	
I _{LIM}	N-MOSFET switch current limit (Q1)	TPS65140, TPS65141 TPS65145	1.6 0.96	2.3 1.37	2.6 1.56	A
r _{DS(on)}	P-MOSFET ON-resistance (Q2)	V _{O1} = 10 V, I _{SW} = 100 mA V _{O1} = 5 V, I _{SW} = 100 mA	9 14	15 22	Ω	
I _{MAX}	Maximum P-MOSFET peak switch current			1	A	
I _{LEAK}	Switch leakage current	V _{SW} = 15 V		1	10	μA
f _{SW}	Oscillator frequency	0°C ≤ T _A ≤ 85°C -40°C ≤ T _A ≤ 85°C	1.295 1.191	1.6 1.6	2.1 2.1	MHz

Electrical Characteristics (continued)
 $V_I = 3.3\text{ V}$, $EN = VIN$, $V_{O1} = 10\text{ V}$, $T_A = -40^\circ\text{C}$ to 85°C , typical values are at $T_A = 25^\circ\text{C}$ (unless otherwise noted)

PARAMETER		TEST CONDITIONS	MIN	TYP	MAX	UNIT
Line regulation		$2.7\text{ V} \leq V_I \leq 5.7\text{ V}$; $I_{LOAD} = 100\text{ mA}$		0.012		%/V
Load regulation		$0\text{ mA} \leq I_O \leq 300\text{ mA}$		0.2		%/A
NEGATIVE CHARGE PUMP V_{O2}						
V_{O2}	Output voltage		-2			V
V_{REF}	Reference voltage		1.205	1.213	1.219	V
V_{FB}	Feedback regulation voltage		-36	0	36	mV
I_{FB}	Feedback input bias current			10	100	nA
$r_{DS(on)}$	Q8 P-Channel switch $r_{DS(on)}$	$I_O = 20\text{ mA}$		4.3	8	Ω
	Q9 N-Channel switch $r_{DS(on)}$			2.9	4.4	
I_O	Maximum output current		20			mA
Line regulation		$7\text{ V} \leq V_{O1} \leq 15\text{ V}$, $I_{LOAD} = 10\text{ mA}$, $V_{O2} = -5\text{ V}$		0.09		%/V
Load regulation		$1\text{ mA} \leq I_O \leq 20\text{ mA}$, $V_{O2} = -5\text{ V}$		0.126		%/mA
POSITIVE CHARGE PUMP V_{O3}						
V_{O3}	Output voltage				30	V
V_{REF}	Reference voltage		1.205	1.213	1.219	V
V_{FB}	Feedback regulation voltage		1.187	1.214	1.238	V
I_{FB}	Feedback input bias current			10	100	nA
$r_{DS(on)}$	Q3 P-Channel switch $r_{DS(on)}$	$I_O = 20\text{ mA}$		9.9	15.5	Ω
	Q4 N-Channel switch $r_{DS(on)}$			1.1	1.8	
	Q5 P-Channel switch $r_{DS(on)}$			4.6	8.5	
	Q6 N-Channel switch $r_{DS(on)}$			1.2	2.2	
V_D	D1 – D4 Shottky diode forward voltage	$I_{D1 - D4} = 40\text{ mA}$		610	720	mV
I_O	Maximum output current		20			mA
Line regulation		$10\text{ V} \leq V_{O1} \leq 15\text{ V}$, $I_{LOAD} = 10\text{ mA}$, $V_{O3} = 27\text{ V}$		0.56		%/V
Load regulation		$1\text{ mA} \leq I_O \leq 20\text{ mA}$, $V_{O3} = 27\text{ V}$		0.05		%/mA
LINEAR REGULATOR CONTROLLER V_{O4}						
V_{O4}	Output voltage	$4.5\text{ V} \leq V_I \leq 5.5\text{ V}$; $10\text{ mA} \leq I_O \leq 500\text{ mA}$	3.2	3.3	3.4	V
I_{BASE}	Maximum base drive current	$V_{IN} - V_{O4} - V_{BE} \geq 0.5\text{ V}^{(1)}$	13.5	19		mA
		$V_{IN} - V_{O4} - V_{BE} \geq 0.75\text{ V}^{(1)}$	20	27		
Line regulation		$4.75\text{ V} \leq V_I \leq 5.5\text{ V}$, $I_{LOAD} = 500\text{ mA}$		0.186		%/V
Load regulation		$1\text{ mA} \leq I_O \leq 500\text{ mA}$, $V_I = 5\text{ V}$		0.064		%/A
Start-up current		$V_{O4} \leq 0.8\text{ V}$	11	20	25	mA

 (1) With V_I = supply voltage of the TPS6514x, V_{O4} = output voltage of the regulator, V_{BE} = basis emitter voltage of external transistor.

Electrical Characteristics (continued)

 $V_I = 3.3\text{ V}$, $EN = VIN$, $V_{O1} = 10\text{ V}$, $T_A = -40^\circ\text{C}$ to 85°C , typical values are at $T_A = 25^\circ\text{C}$ (unless otherwise noted)

PARAMETER		TEST CONDITIONS	MIN	TYP	MAX	UNIT
SYSTEM POWER GOOD (PG)						
$V(PG, V_{O1})$	Power good threshold ⁽²⁾		-12	-8.75% V_{O1}	-6	V
$V(PG, V_{O2})$			-13	-9.5% V_{O2}	-5	V
$V(PG, V_{O3})$			-11	-8% V_{O3}	-5	V
VOL	PG output low voltage	$I_{(sink)} = 500\ \mu\text{A}$			0.3	V
IL	PG output leakage current	$VPG = 5\text{ V}$		0.001	1	μA

(2) The power good goes high when all 3 outputs (V_{O1} , V_{O2} , V_{O3}) are above their threshold. The power good goes low as soon as one of the outputs is below their threshold.

6.6 Dissipation Ratings

PACKAGE	$R_{\theta JA}$	$T_A \leq 25^\circ\text{C}$ POWER RATING	$T_A = 70^\circ\text{C}$ POWER RATING	$T_A = 85^\circ\text{C}$ POWER RATING
24-Pin TSSOP	30.13 C°/W (PWP soldered)	3.3 W	1.83 W	1.32 W
24-Pin VQFN	30 C°/W	3.3 W	1.8 W	1.3 W

6.7 Typical Characteristics

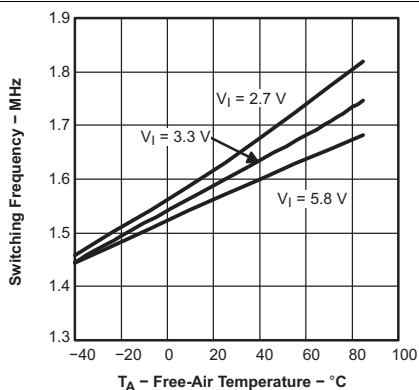

Figure 1. Switching Frequency vs Free-Air Temperature

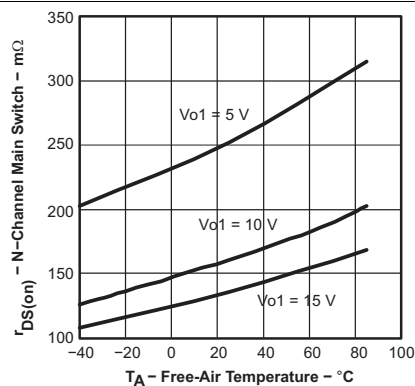

Figure 2. $r_{DS(on)}$ N-Channel Main Switch vs Free-Air Temperature

7 Detailed Description

7.1 Overview

The TPS6514x series consists of a main boost converter operating with a fixed switching frequency of 1.6 MHz to allow for small external components. The boost converter output voltage V_{O1} is also the input voltage, connected through the pin SUP, for the positive and negative charge pump. The linear regulator controller is independent from this system with its own enable pin. This allows the linear regulator controller to continue to operate while the other supply rails are disabled or in shutdown due to a fault condition on one of their outputs. See [Functional Block Diagram](#) for more information.

7.2 Functional Block Diagram

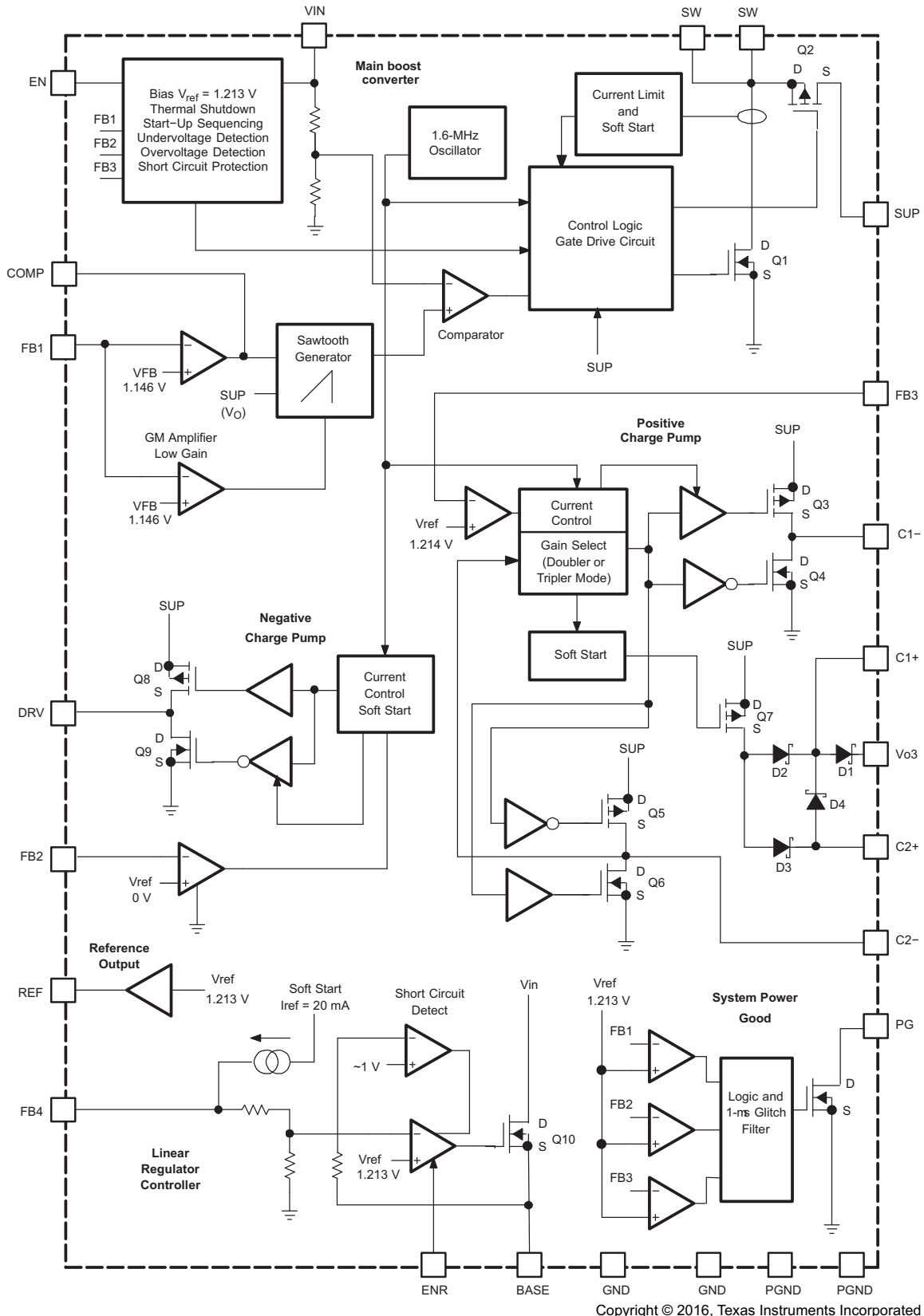

7.3 Feature Description

7.3.1 Main Boost Converter

The main boost converter operates with PWM and a fixed switching frequency of 1.6 MHz. The converter uses a unique fast response, voltage mode controller scheme with input voltage feedforward. This achieves excellent line and load regulation (0.2% A load regulation typical) and allows the use of small external components. To add higher flexibility to the selection of external component values, the device uses external loop compensation. Although the boost converter looks like a nonsynchronous boost converter topology operating in discontinuous mode at light load, the TPS6514x series maintains continuous conduction even at light load currents. This is accomplished using the Virtual Synchronous Converter Technology for improved load transient response. This architecture uses an external Schottky diode and an integrated MOSFET in parallel connected between SW and SUP (see [Functional Block Diagram](#)). The integrated MOSFET Q2 allows the inductor current to become negative at light load conditions. For this purpose, a small integrated P-channel MOSFET with typically 10- Ω $r_{DS(on)}$ is sufficient. When the inductor current is positive, the external Schottky diode with the lower forward voltage conducts the current. This causes the converter to operate with a fixed frequency in continuous conduction mode over the entire load current range. This avoids the ringing on the switch pin as seen with a standard nonsynchronous boost converter and allows a simpler compensation for the boost converter.

7.3.2 Power Good Output

The TPS6514x series has an open-drain power good output with a maximum sink capability of 1 mA. The power good output goes high as soon as the main boost converter V_{O1} and the negative and the positive charge pumps are within regulation. The power good output goes low as soon as one of the outputs is out of regulation. In this case, the device goes into shutdown at the same time. See [Electrical Characteristics](#) for the power good thresholds.

7.3.3 Enable and Power-On Sequencing (EN, ENR)

The device has two enable pins. These pins must be terminated and not left floating to prevent faulty operation. Pulling the enable pin (EN) high enables the device and starts the power-on sequencing with the main boost converter V_{O1} coming up first, then the negative and positive charge pump. The linear regulator has an independent enable pin (ENR). Pulling this pin low disables the regulator, and pulling this pin high enables this regulator.

If the enable pin (EN) is pulled high, the device starts its power-on sequencing. The main boost converter starts up first with its soft start. If the output voltage reaches 91.25% of its output voltage, the negative charge pump comes up next. The negative charge pump starts with a soft start and when the output voltage reaches 91% of the nominal value, the positive charge pump comes up with the soft start. Pulling the enable pin low shuts down the device. Dependent on load current and output capacitance, each of the outputs comes down.

7.3.4 Positive Charge Pump

The TPS6514x series has a fully regulated integrated positive charge pump generating V_{O3} . The input voltage for the charge pump is applied to the SUP pin that is equal to the output of the main boost converter V_{O1} . The charge pump is capable of supplying a minimum load current of 20 mA. Higher load currents are possible depending on the voltage difference between V_{O1} and V_{O3} . See [Figure 22](#) and [Figure 23](#).

7.3.5 Negative Charge Pump

The TPS6514x series has a regulated negative charge pump using two external Schottky diodes. The input voltage for the charge pump is applied to the SUP pin that is connected to the output of the main boost converter V_{O1} . The charge pump inverts the main boost converter output voltage and is capable of supplying a minimum load current of 20 mA. Higher load currents are possible depending on the voltage difference between V_{O1} and V_{O2} . See [Figure 21](#).

7.3.6 Linear Regulator Controller

The TPS6514x series includes a linear regulator controller to generate a 3.3-V rail which is useful when the system is powered from a 5-V supply. The regulator is independent from the other voltage rails of the device and has its own enable (ENR). Because most of the systems require this voltage rail to come up first, TI recommends using a R-C delay on EN. This delays the start-up of the main boost converter which reduces the inrush current as well.

Feature Description (continued)

7.3.7 Soft Start

The main boost converter as well as the charge pumps and linear regulator have an internal soft start. This avoids heavy voltage drops at the input voltage rail or at the output of the main boost converter V_{O1} during start-up. See [Figure 19](#) and [Figure 20](#). During soft start of the main boost converter V_{O1} , the internal current limit threshold is increased in three steps. The device starts with the first step where the current limit is set to 2/5 of the typical current limit (2/5 of 2.3 A) for 1024 clock cycles then increased to 3/5 of the current limit for 1024 clock cycles and the 3rd step is the full current limit. The TPS65141 has an extended soft-start time where each step is 2048 clock cycles.

7.3.8 Fault Protection

All of the outputs of the TPS65140 and TPS65145 have short-circuit detection and cause the device to go into shutdown. The TPS65141, as an exception, does not enter shutdown in case one of the outputs falls below its power good threshold. The main boost converter has overvoltage and undervoltage protection. If the output voltage V_{O1} rises above the overvoltage protection threshold of typically 5% of V_{O1} , then the device stops switching, but remains operational. When the output voltage falls below this threshold, the converter continues operation. When the output voltage falls below the undervoltage protection threshold of typically 8.75% of V_{O1} , because of a short-circuit condition, the TPS65140 and TPS65145 goes into shutdown. Because there is a direct pass from the input to the output through the diode, the short-circuit condition remains. If this condition must be avoided, a fuse at the input or an output disconnect using a single transistor and resistor is required. The negative and positive charge pumps have an undervoltage lockout (UVLO) to protect the LCD panel of possible latch-up conditions due to a short-circuit condition or faulty operation. When the negative output voltage is typically above 9.5% of its output voltage (closer to ground), then the device enters shutdown. When the positive charge pump output voltage, V_{O3} , is below 8% typical of its output voltage, the device goes into shutdown. See the fault protection thresholds in [Electrical Characteristics](#). The device is enabled by toggling the enable pin (EN) below 0.4 V or by cycling the input voltage below the UVLO of 1.7 V. The linear regulator reduces the output current to 20 mA typical under a short-circuit condition when the output voltage is typically < 1 V. See [Functional Block Diagram](#). The linear regulator does not go into shutdown under a short-circuit condition.

7.3.9 Thermal Shutdown

A thermal shutdown is implemented to prevent damage due to excessive heat and power dissipation. Typically, the thermal shutdown threshold is 160°C. If this temperature is reached, the device goes into shutdown. The device can be enabled by toggling the enable pin to low and back to high or by cycling the input voltage to GND and back to V_I again.

7.4 Device Functional Modes

7.4.1 Enabling and Disabling the Device

The TPS6514x turns on when the input voltage is higher than V_{UVLO} and the enable pin EN is pulled to HIGH. The device goes into shutdown and all its function apart from the linear regulator are disabled if one of these conditions is present:

- enable pin EN is pulled to LOW
- V_{O1} , V_{O2} , or V_{O3} is out of regulation (only for TPS65140 and TPS65145)

8 Application and Implementation

NOTE

Information in the following applications sections is not part of the TI component specification, and TI does not warrant its accuracy or completeness. TI's customers are responsible for determining suitability of components for their purposes. Customers should validate and test their design implementation to confirm system functionality.

8.1 Application Information

The TPS6514x devices have been designed to provide the input supply voltages for the source drivers and gate drivers in LCD displays. Additionally, they include a linear regulator controller that can be used with an external transistor to provide a regulated 3.3-V output for the digital circuits for LCD panels powered by a 5-V supply rail.

8.2 Typical Application

Figure 3 shows a typical application circuit for a monitor display powered from a 5-V supply. It generates up to 350 mA at 15 V to power the source drivers, and 20 mA at 30 V and -12 V to power the gate drivers.

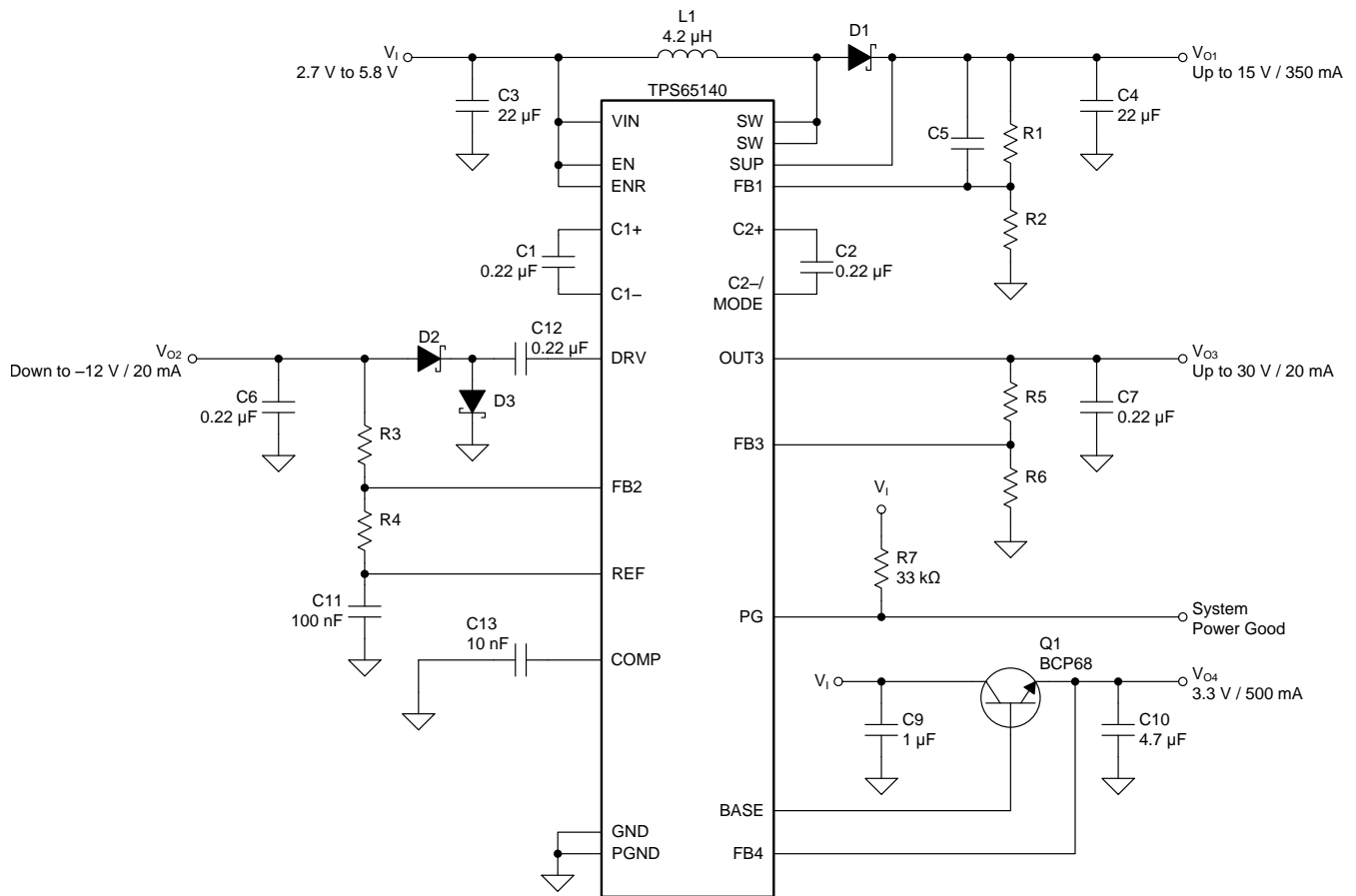

Copyright © 2016, Texas Instruments Incorporated

Figure 3. Typical Application Schematic

Typical Application (continued)

8.2.1 Design Requirements

Table 1 shows the design parameters for this example.

Table 1. Design Requirements

PARAMETER		VALUE
V _I	Input supply voltage	2.7 V to 5.8 V
V _{O1}	Boost converter output voltage and current	Up to 15 V at 350 mA
V _{O3}	Positive charge pump output voltage and current	Up to 30 V at 20 mA
V _{O2}	Negative charge pump output voltage and current	Down to –12 V at 20 mA
V _{O4}	Linear regulator controller output voltage and current	3.3 V at 500 mA

8.2.2 Detailed Design Procedure

8.2.2.1 Boost Converter Design Procedure

The first step in the design procedure is to calculate the maximum possible output current of the main boost converter under certain input and output voltage conditions. The following is an example for a 3.3-V to 10-V conversion:

V_{IN} = 3.3 V, V_{OUT} = 10 V, Switch voltage drop V_{SW} = 0.5 V, Schottky diode forward voltage V_D = 0.8 V

1. Duty cycle:

$$D = \frac{V_{OUT} - V_D + V_{IN}}{V_{OUT} - V_D + V_{SW}} = \frac{10 \text{ V} - 0.8 \text{ V} + 3.3 \text{ V}}{10 \text{ V} - 0.8 \text{ V} + 0.5 \text{ V}} = 0.73 \quad (1)$$

2. Average inductor current:

$$I_L = \frac{I_{OUT}}{1 - D} = \frac{300 \text{ mA}}{1 - 0.73} = 1.11 \text{ A} \quad (2)$$

3. Inductor peak-to-peak ripple current:

$$\Delta I_L = \frac{(V_{IN} - V_{SW}) \times D}{f_s \times L} = \frac{(3.3 \text{ V} - 0.5 \text{ V}) \times 0.73}{1.6 \text{ MHz} \times 4.2 \mu\text{H}} = 304 \text{ mA} \quad (3)$$

4. Peak switch current:

$$I_{SWPeak} = I_L + \frac{\Delta I_L}{2} = 1.11 \text{ A} + \frac{304 \text{ mA}}{2} = 1.26 \text{ A} \quad (4)$$

The integrated switch, the inductor, and the external Schottky diode must be able to handle the peak switch current. The calculated peak switch current must be equal to or lower than the minimum N-MOSFET switch current limit as specified in [Electrical Characteristics](#) (1.6 A for the TPS65140 and TPS65141 and 0.96 A for the TPS65145). If the peak switch current is higher, then the converter cannot support the required load current. This calculation must be done for the minimum input voltage where the peak switch current is highest. The calculation includes conduction losses like switch r_{DS(on)} (0.5 V) and diode forward drop voltage losses (0.8 V). Additional switching losses, inductor core and winding losses, and so forth, require a slightly higher peak switch current in the actual application. The above calculation still allows for a good design and component selection.

8.2.2.1.1 Inductor Selection

Several inductors work with the TPS6514x. Especially with the external compensation, the performance can be adjusted to the specific application requirements. The main parameter for the inductor selection is the saturation current of the inductor which must be higher than the peak switch current as calculated above with additional margin to cover for heavy load transients and extreme start-up conditions. Another method is to choose the inductor with a saturation current at least as high as the minimum switch current limit of 1.6 A for the TPS65140 and TPS65141 and 0.96 A for the TPS65145. The different switch current limits allow selection of a physically smaller inductor when less output current is required. The second important parameter is the inductor DC resistance. Usually, the lower the DC resistance, the higher the efficiency. However, the inductor DC resistance is not the only parameter determining the efficiency. Especially for a boost converter where the inductor is the

energy storage element, the type and material of the inductor influences the efficiency as well. Especially at high switching frequencies of 1.6 MHz, inductor core losses, proximity effects, and skin effects become more important. Usually, an inductor with a larger form factor yields higher efficiency. The efficiency difference between different inductors can vary from 2% to 10%. For the TPS6514x, inductor values from 3.3 μH to 6.8 μH are a good choice but other values can be used as well. Possible inductors are shown in [Table 2](#).

Table 2. Inductor Selection

DEVICE	INDUCTOR VALUE	COMPONENT SUPPLIER	DIMENSIONS / mm	ISAT/DCR
TPS65140	4.7 μH	Coilcraft DO1813P-472HC	8.89 × 6.1 × 5	2.6 A, 54 m Ω
	4.2 μH	Sumida CDRH5D28 4R2	5.7 × 5.7 × 3	2.2 A, 23 m Ω
	4.7 μH	Sumida CDC5D23 4R7	6 × 6 × 2.5	1.6 A, 48 m Ω
	3.3 μH	Wuerth Elektronik 744042003	4.8 × 4.8 × 2	1.8 A, 65 m Ω
	4.2 μH	Sumida CDRH6D12 4R2	6.5 × 6.5 × 1.5	1.8 A, 60 m Ω
	3.3 μH	Sumida CDRH6D12 3R3	6.5 × 6.5 × 1.5	1.9 A, 50 m Ω
TPS65145	3.3 μH	Sumida CDPH4D19 3R3	5.1 × 5.1 × 2	1.5 A, 26 m Ω
	3.3 μH	Coilcraft DO1606T-332	6.5 × 5.2 × 2	1.4 A, 120 m Ω
	3.3 μH	Sumida CDRH2D18/HP 3R3	3.2 × 3.2 × 2	1.45 A, 69 m Ω
	4.7 μH	Wuerth Elektronik 744010004	5.5 × 3.5 × 1	1 A, 260 m Ω
	3.3 μH	Coilcraft LPO6610-332M	6.6 × 5.5 × 1	1.3 A, 160 m Ω

8.2.2.1.2 Output Capacitor Selection

For best output voltage filtering, TI recommends a low-ESR output capacitor. Ceramic capacitors have a low ESR value but depending on the application, tantalum capacitors can be used as well. A 22- μF ceramic output capacitor works for most of the applications. Higher capacitor values can be used to improve load transient regulation. See [Table 2](#) for the selection of the output capacitor. The output voltage ripple can be calculated as:

$$\Delta V_{\text{OUT}} = \frac{I_{\text{OUT}}}{C_{\text{OUT}}} \times \left(\frac{1}{f_{\text{S}}} - \frac{I_{\text{P}} \times L}{V_{\text{OUT}} + V_{\text{D}} - V_{\text{IN}}} \right) + I_{\text{P}} \times \text{ESR}$$

where

- I_{P} = Peak switch current as calculated in the previous section with $I_{\text{SW(peak)}}$
- L = Selected inductor value
- I_{OUT} = Normal load current
- f_{S} = Switching frequency
- V_{D} = Rectifier diode forward voltage (typical 0.3 V)
- C_{OUT} = Selected output capacitor
- ESR = Output capacitor ESR value

(5)

8.2.2.1.3 Input Capacitor Selection

For good input voltage filtering, TI recommends low-ESR ceramic capacitors. A 22- μF ceramic input capacitor is sufficient for most of applications. For better input voltage filtering, this value can be increased. See [Table 3](#) and the typical applications for input capacitor recommendations.

Table 3. Input and Output Capacitors Selection

CAPACITOR	VOLTAGE RATING	COMPONENT SUPPLIER	COMMENTS
22 μF , 1210	16 V	Taiyo Yuden EMK325BY226MM	C_{O}
22 μF , 1206	6.3 V	Taiyo Yuden JMK316BJ226	C_{I}

8.2.2.1.4 Rectifier Diode Selection

To achieve high efficiency, a Schottky diode must be used. The voltage rating must be higher than the maximum output voltage of the converter. The average forward current must be equal to the average inductor current of the converter. The main parameter influencing the efficiency of the converter is the forward voltage and the reverse leakage current of the diode; both must be as low as possible. Possible diodes are: On Semiconductor MBRM120L, Microsemi UPS120E, and Fairchild Semiconductor MBR5130L.

8.2.2.1.5 Converter Loop Design and Stability

The TPS6514x converter loop can be externally compensated and allows access to the internal transconductance error amplifier output at the COMP pin. A small feedforward capacitor across the upper feedback resistor divider speeds up the circuit as well. To test the converter stability and load transient performance of the converter, a load step from 50 mA to 250 mA is applied, and the output voltage of the converter is monitored. Applying load steps to the converter output is a good tool to judge the stability of such a boost converter.

8.2.2.1.6 Design Procedure Quick Steps

1. Select the feedback resistor divider to set the output voltage.
2. Select the feedforward capacitor to place a zero at 50 kHz.
3. Select the compensation capacitor on pin COMP. The smaller the value, the higher the low frequency gain.
4. Use a 50-kΩ potentiometer in series to C_C and monitor V_{OUT} during load transients. Fine tune the load transient by adjusting the potentiometer. Select a resistor value that comes closest to the potentiometer resistor value. This must be done at the highest V_{in} and highest load current because stability is most critical at these conditions.

8.2.2.1.7 Setting the Output Voltage and Selecting the Feedforward Capacitor

The output voltage is set by the external resistor divider and is calculated as:

$$V_{OUT} = 1.146 V \times \left(1 + \frac{R1}{R2} \right) \tag{6}$$

Across the upper resistor, a bypass capacitor is required to speed up the circuit during load transients as shown in [Figure 4](#).

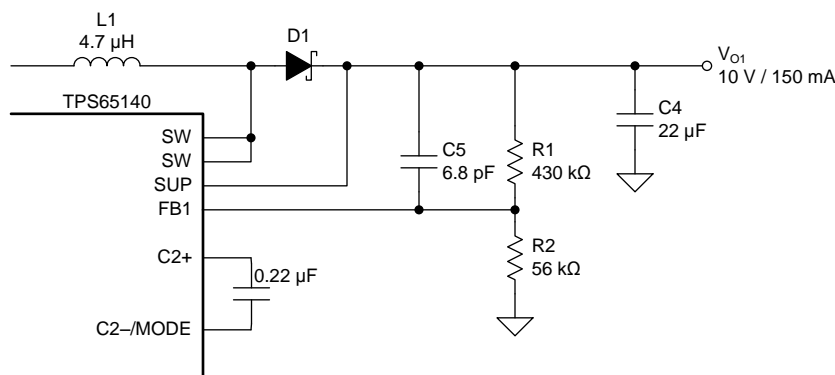

Copyright © 2016, Texas Instruments Incorporated

Figure 4. Feedforward Capacitor

Together with R1 the bypass capacitor C8 sets a zero in the control loop at approximately 50 kHz:

$$C8 = \frac{1}{2 \times \pi \times f_z \times R1} = \frac{1}{2 \times \pi \times 50 \text{ kHz} \times R1} \tag{7}$$

A value closest to the calculated value must be used. Larger feedforward capacitor values reduce the load regulation of the converter and cause load steps as shown in [Figure 5](#).

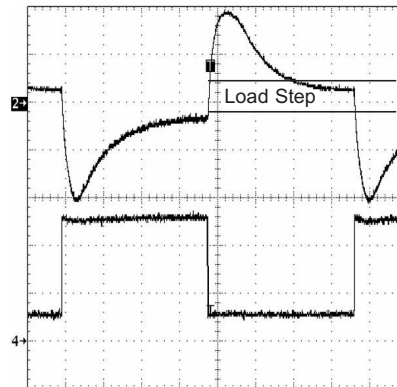
Figure 5. Load Step Caused by a Too Large Feedforward Capacitor Value

8.2.2.1.8 Compensation

The regulator loop can be compensated by adjusting the external components connected to the COMP pin. The COMP pin is connected to the output of the internal transconductance error amplifier. A typical compensation scheme is shown in [Figure 6](#).

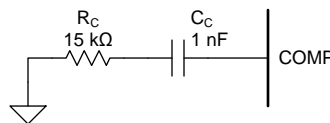
Figure 6. Compensation Network

The compensation capacitor C_C adjusts the low frequency gain, and the resistor value adjusts the high frequency gain. The following formula calculates at what frequency the resistor increases the high frequency gain.

$$f_z = \frac{1}{2 \times \pi \times C_C \times R_C} \quad (8)$$

Lower input voltages require a higher gain and a lower compensation capacitor value. A good start is $C_C = 1 \text{ nF}$ for a 3.3-V input and $C_C = 2.2 \text{ nF}$ for a 5-V input. If the device operates over the entire input voltage range from 2.7 V to 5.8 V, TI recommends a larger compensation capacitor up to 10 nF. [Figure 7](#) shows the load transient with a larger compensation capacitor, and [Figure 8](#) shows a smaller compensation capacitor.

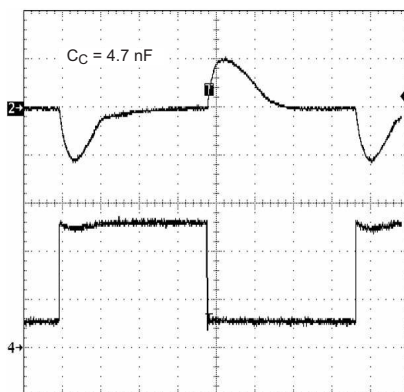
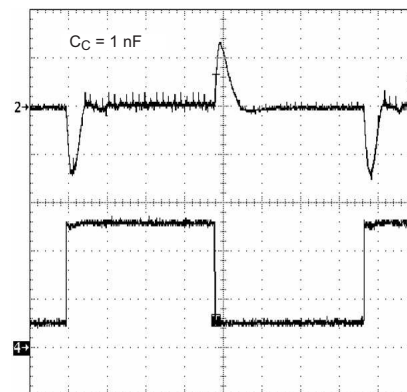
Figure 7. $C_C = 4.7 \text{ nF}$

Figure 8. $C_C = 1 \text{ nF}$

Lastly, R_C must be selected. A good practice is to use a 50-k Ω potentiometer and adjust the potentiometer for the best load transient where no oscillations should occur. These tests have to be done at the highest V_{IN} and highest load current because the converter stability is most critical under these conditions. [Figure 9](#), [Figure 10](#), and [Figure 11](#) show the fine tuning of the loop with R_C .

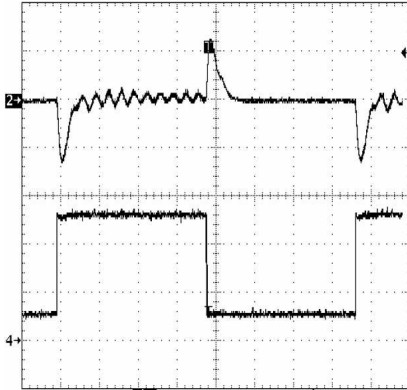

Figure 9. Overcompensated (Damped Oscillation), R_C is Too Large

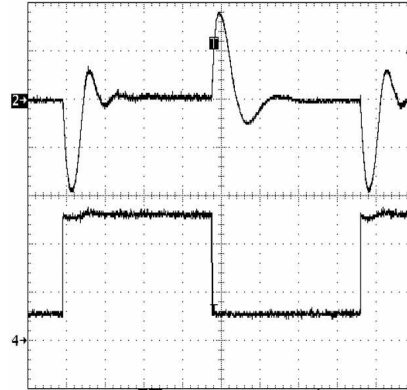

Figure 10. Undercompensated (Loop is Too Slow), R_C is Too Small



Figure 11. Optimum, R_C is Ideal

8.2.2.1.9 Negative Charge Pump

The negative charge pump provides a regulated output voltage by inverting the main output voltage, V_{O1} . The negative charge pump output voltage is set with external feedback resistors.

The maximum load current of the negative charge pump depends on the voltage drop across the external Schottky diodes, the internal ON-resistance of the charge pump MOSFETS Q8 and Q9, and the impedance of the flying capacitor, C12. When the voltage drop across these components is larger than the voltage difference from V_{O1} to V_{O2} , the charge pump is in drop out, providing the maximum possible output current. Therefore, the higher the voltage difference between V_{O1} and V_{O2} , the higher the possible load current. See [Figure 21](#) for the possible output current versus boost converter voltage V_{O1} and the calculations below.

$$V_{OUTmin} = -(V_{O1} - 2 V_F - I_O (2 \times r_{DS(on)Q8} + 2 \times r_{DS(on)Q9} + X_{cfly})) \quad (9)$$

Setting the output voltage:

$$V_{OUT} = -V_{REF} \times \frac{R3}{R4} = -1.213 \text{ V} \times \frac{R3}{R4} \quad (10)$$

$$R3 = R4 \times \frac{|V_{OUT}|}{V_{REF}} = R4 \times \frac{|V_{OUT}|}{1.213} \quad (11)$$

The lower feedback resistor value, R4, must be in a range from 40 kΩ to 120 kΩ or the overall feedback resistance must be within 500 kΩ to 1 MΩ. Smaller values load the reference too heavy and larger values may cause stability problems. The negative charge pump requires two external Schottky diodes. The peak current rating of the Schottky diode must be twice the load current of the output. For a 20-mA output current, the dual Schottky diode BAT54 or similar is a good choice.

8.2.2.1.10 Positive Charge Pump

The positive charge pump can be operated in a voltage doubler mode or a voltage tripler mode depending on the configuration of the C2+ and C2-/MODE pins. Leaving the C2+ pin open and connecting C2-/MODE to GND forces the positive charge pump to operate in a voltage doubler mode. If higher output voltages are required the positive charge pump can be operated as a voltage tripler. To operate the charge pump in the voltage tripler mode, a flying capacitor must be connected to C2+ and C2-/MODE.

The maximum load current of the positive charge pump depends on the voltage drop across the internal Schottky diodes, the internal ON-resistance of the charge pump MOSFETS, and the impedance of the flying capacitor. When the voltage drop across these components is larger than the voltage difference $V_{O1} \times 2$ to V_{O3} (doubler mode) or $V_{O1} \times 3$ to V_{O3} (tripler mode), then the charge pump is in dropout, providing the maximum possible output current. Therefore, the higher the voltage difference between $V_{O1} \times 2$ (doubler) or $V_{O1} \times 3$ (tripler) to V_{O3} , the higher the possible load current. See [Figure 22](#) and [Figure 23](#) for output current versus boost converter voltage, V_{O1} , and the following calculations.

Voltage doubler:

$$V_{O3\max} = 2 \times V_{O1} - (2 V_F + 2 \times I_O \times (2 \times r_{DS(on)Q5} + r_{DS(on)Q3} + r_{DS(on)Q4} + X_{C1})) \quad (12)$$

Voltage tripler:

$$V_{O3\max} = 3 \times V_{O1} - (4 \times V_F + 2 \times I_O \times (3 \times r_{DS(on)Q5} + r_{DS(on)Q3} + r_{DS(on)Q4} + X_{C1} + X_{C2})) \quad (13)$$

The output voltage is set by the external resistor divider and is calculated as:

$$V_{OUT} = 1.214 \times \left(1 + \frac{R5}{R6} \right) \quad (14)$$

$$R5 = R6 \times \left(\frac{V_{OUT}}{V_{FB}} - 1 \right) = R6 \times \left(\frac{V_{OUT}}{1.214} - 1 \right) \quad (15)$$

8.2.2.1.11 Linear Regulator Controller

The TPS6514x includes a linear regulator controller to generate a 3.3-V rail when the system is powered from a 5-V supply. Because an external NPN transistor is required, the input voltage of the TPS6514x applied to VIN must be higher than the output voltage of the regulator. To provide a minimum base drive current of 13.5 mA, a minimum internal voltage drop of 500 mV from V_I to V_{BASE} is required. This can be translated into a minimum input voltage on VIN for a certain output voltage as the following calculation shows:

$$V_{I(\min)} = V_{O4} + V_{BE} + 0.5 V \quad (16)$$

The base drive current together with the h_{FE} of the external transistor determines the possible output current. Using a standard NPN transistor like the BCP68 allows an output current of 1 A and using the BCP54 allows a load current of 337 mA for an input voltage of 5 V. Other transistors can be used as well, depending on the required output current, power dissipation, and PCB space. The device is stable with a 4.7-μF ceramic output capacitor. Larger output capacitor values can be used to improve the load transient response when higher load currents are required.

8.2.3 Application Curves

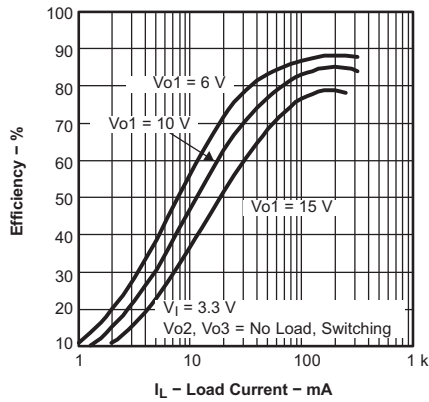

Figure 12. Efficiency vs Load Current

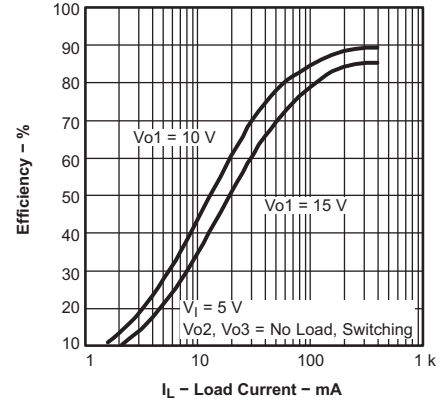

Figure 13. Efficiency vs Load Current

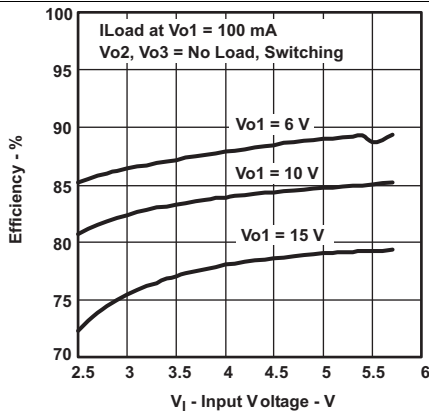

Figure 14. Efficiency vs Input Voltage

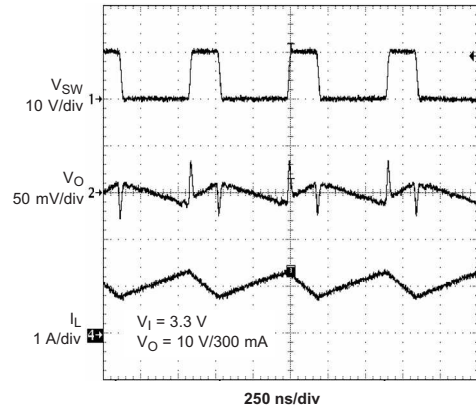

Figure 15. PWM Operation Continuous Mode

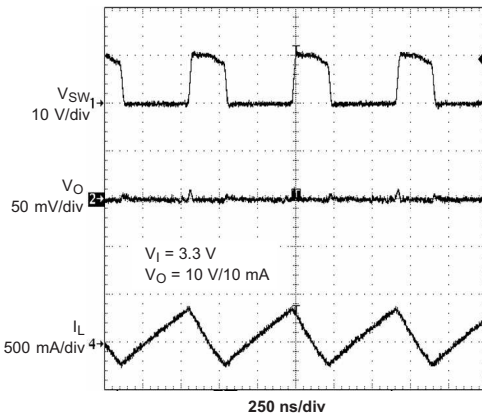

Figure 16. PWM Operation at Light Load

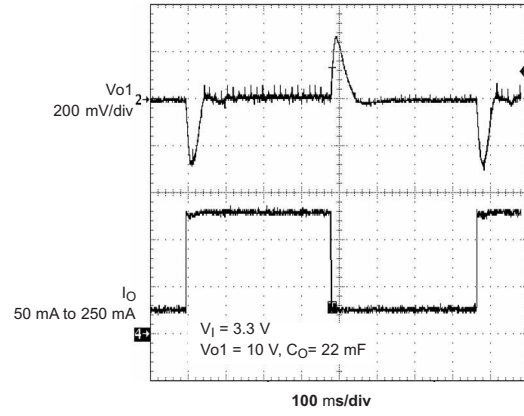

Figure 17. Load Transient Response

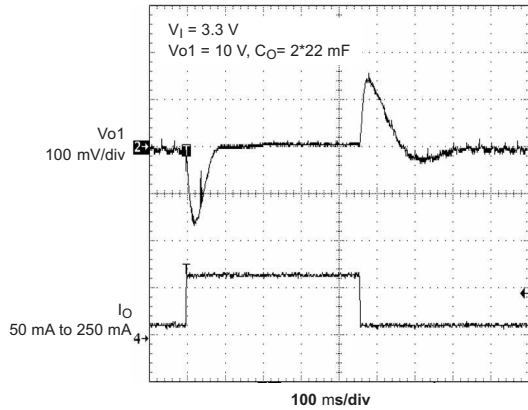

Figure 18. Load Transient Response

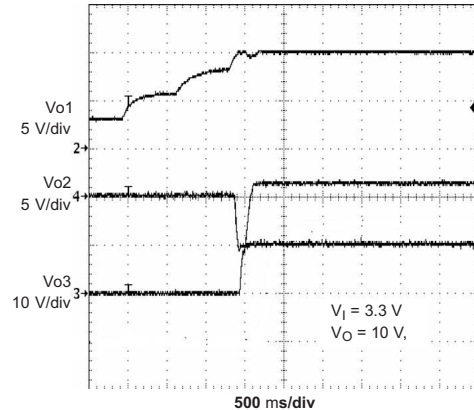

Figure 19. Power-Up Sequencing

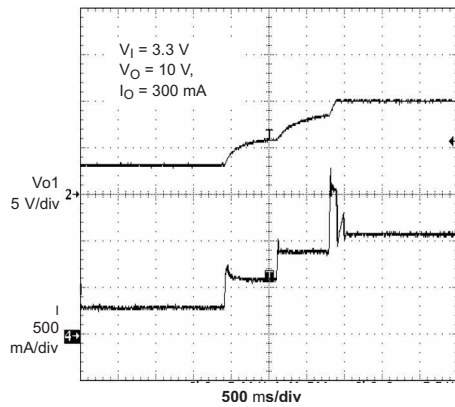

Figure 20. Soft Start V_{O1}

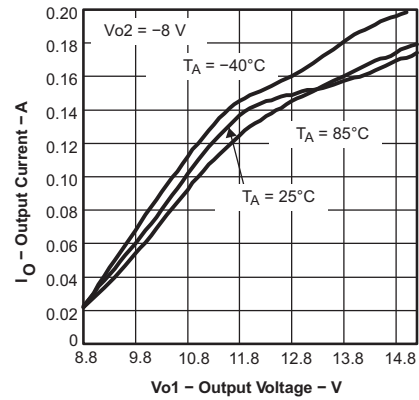

Figure 21. V_{O2} Maximum Load Current

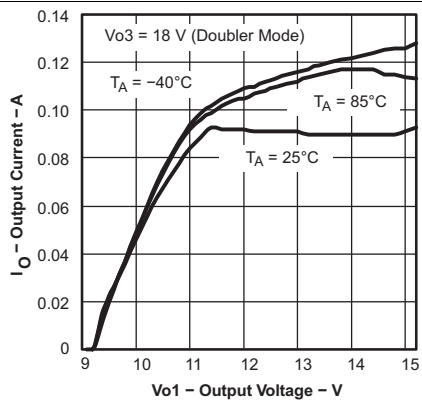

Figure 22. V_{O3} Maximum Load Current

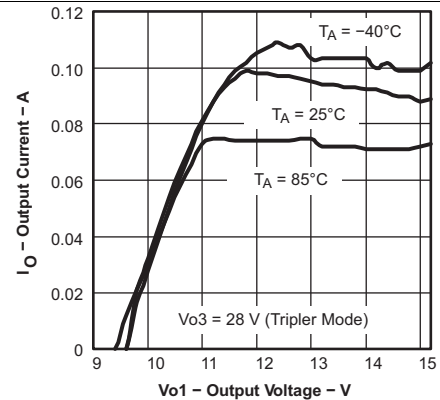
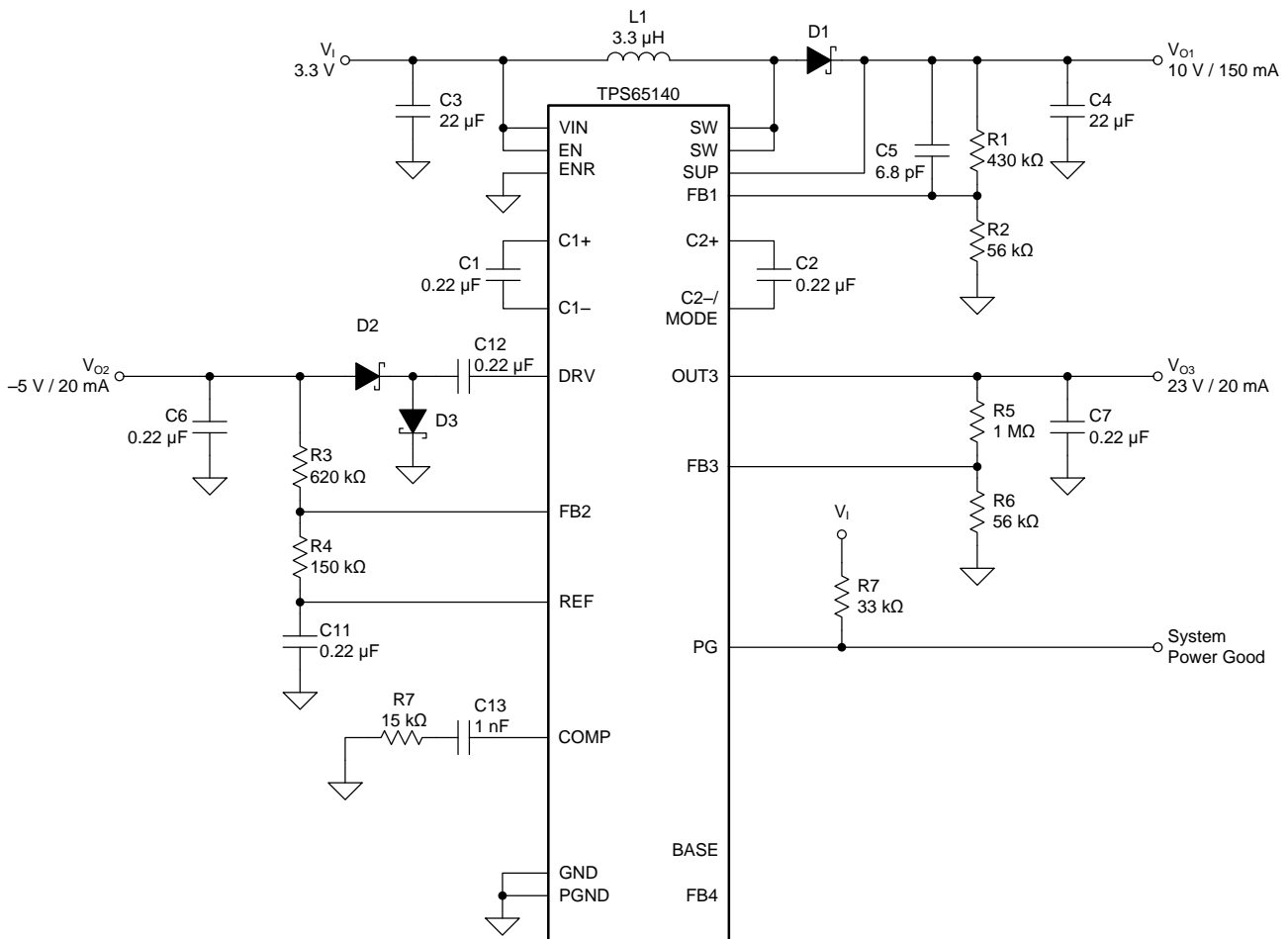

Figure 23. V_{O3} Maximum Load Current

8.3 System Examples



Copyright © 2016, Texas Instruments Incorporated

Figure 24. Typical Application, Notebook Supply

System Examples (continued)

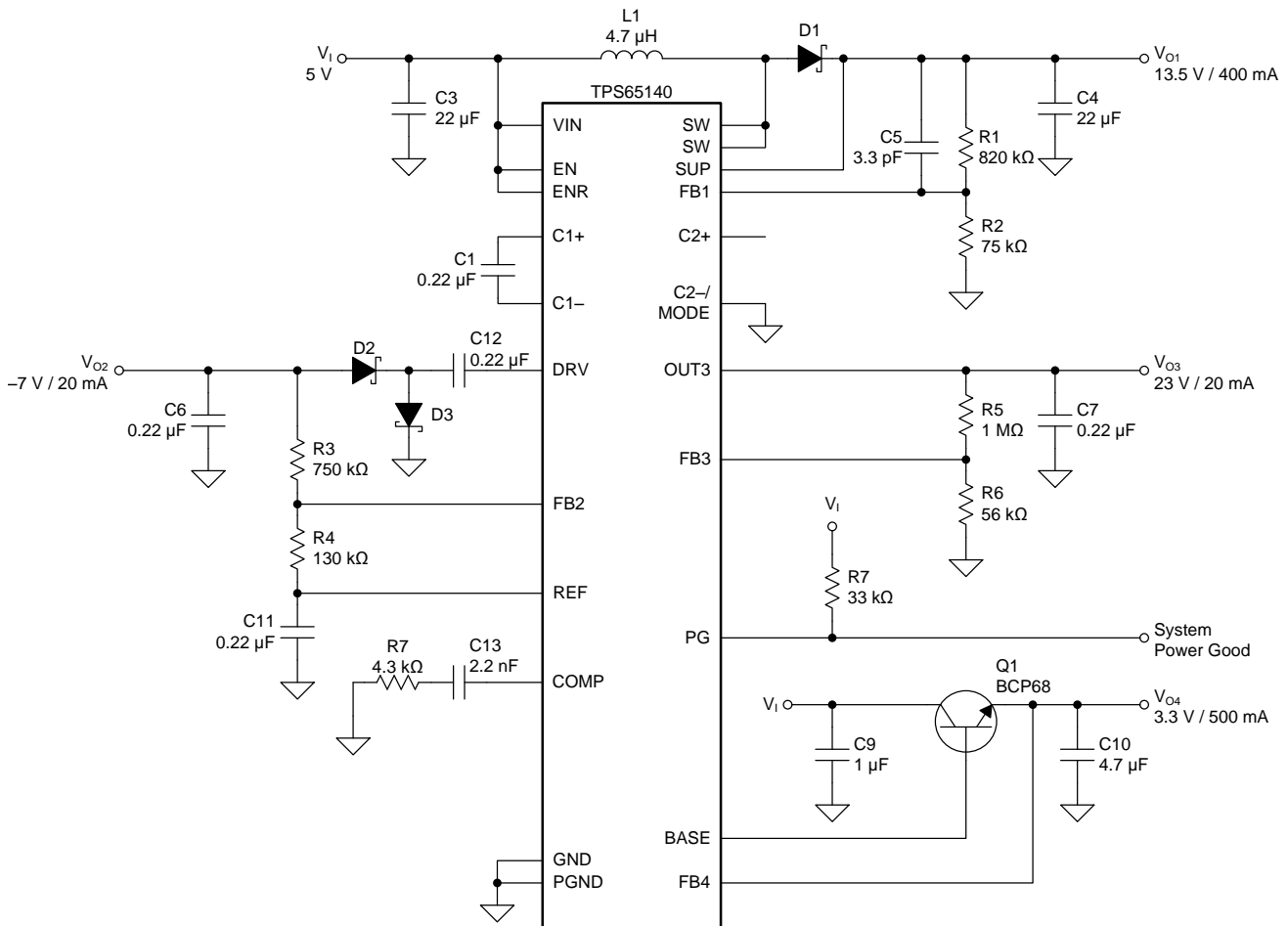

Copyright © 2016, Texas Instruments Incorporated

Figure 25. Typical Application, Monitor Supply

9 Power Supply Recommendations

The TPS6514x devices are designed to operate from an input voltage supply range from 2.7 V to 5.8 V. This input supply must be well regulated. The input capacitance shown in the application schematics in this data sheet is sufficient for typical applications.

10 Layout

10.1 Layout Guidelines

For all switching power supplies, the layout is an important step in the design, especially at high-peak currents and switching frequencies. If the layout is not carefully designed, the regulator might show stability and EMI problems. TI recommends the following PCB layout guidelines for the TPS6514x devices:

- Connect PGND and AGND together on the same ground plane.
- Connect all capacitor grounds and PGND together on a common ground plane.
- Place the input filter capacitor as close as possible to the input pin of the IC.
- Route first the traces carrying high-switching currents with wide and short traces.
- Isolate analog signal paths from power paths.
- If vias are necessary, try to use more than one in parallel to decrease parasitics, especially for power traces.
- Solder the thermal pad to the PCB for good thermal performance

10.2 Layout Example

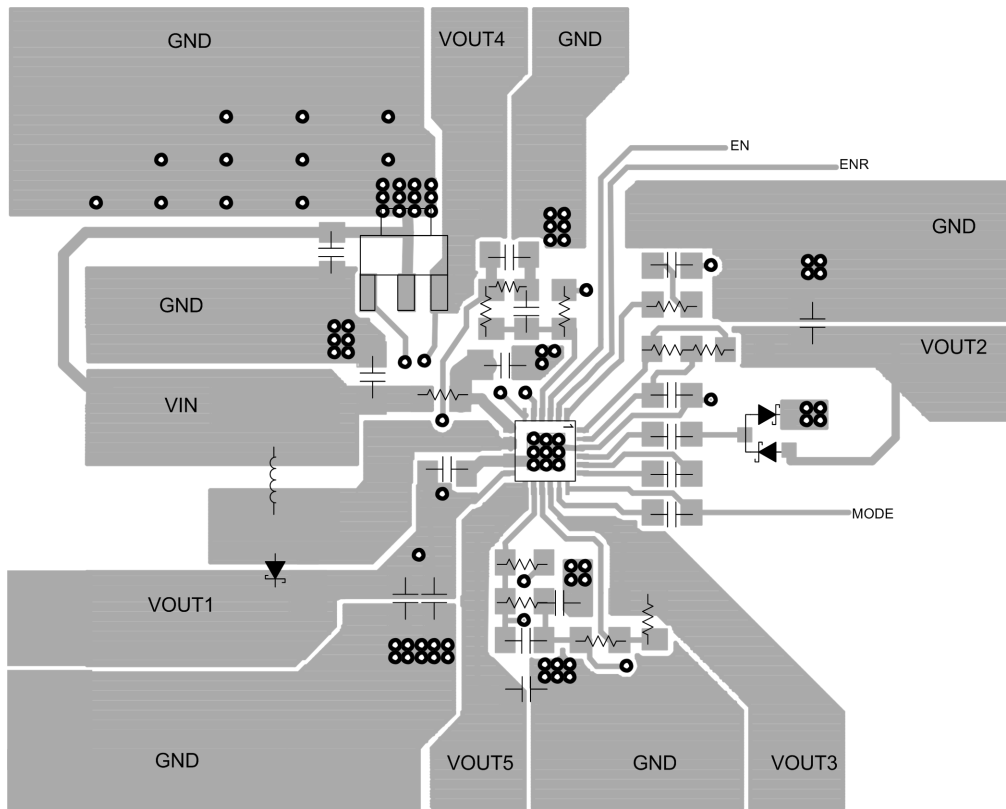

Figure 26. PCB Layout Example

10.3 Thermal Considerations

An influential component of the thermal performance of a package is board design. To take full advantage of the heat dissipation abilities of the PowerPAD or VQFN package with exposed thermal die, a board that acts similar to a heatsink and allows for the use of an exposed (and solderable) deep downset pad must be used. For further information, see Texas Instruments application notes [PowerPAD Thermally Enhanced Package](#) and [Power Pad Made Easy](#). For the VQFN package, see the application report [QFN/SON PCB Attachment](#). Especially for the VQFN package, it is required to solder down the thermal pad to achieve the required thermal resistance.

11 Device and Documentation Support

11.1 Device Support

11.1.1 Third-Party Products Disclaimer

TI'S PUBLICATION OF INFORMATION REGARDING THIRD-PARTY PRODUCTS OR SERVICES DOES NOT CONSTITUTE AN ENDORSEMENT REGARDING THE SUITABILITY OF SUCH PRODUCTS OR SERVICES OR A WARRANTY, REPRESENTATION OR ENDORSEMENT OF SUCH PRODUCTS OR SERVICES, EITHER ALONE OR IN COMBINATION WITH ANY TI PRODUCT OR SERVICE.

11.2 Documentation Support

11.2.1 Related Documentation

For related documentation see the following:

- [PowerPAD Thermally Enhanced Package](#) (SLMA002)
- [Power Pad Made Easy](#) (SLMA004)
- [QFN/SON PCB Attachment](#) (SLUA271)

11.3 Related Links

The table below lists quick access links. Categories include technical documents, support and community resources, tools and software, and quick access to sample or buy.

Table 4. Related Links

PARTS	PRODUCT FOLDER	SAMPLE & BUY	TECHNICAL DOCUMENTS	TOOLS & SOFTWARE	SUPPORT & COMMUNITY
TPS65140	Click here	Click here	Click here	Click here	Click here
TPS65141	Click here	Click here	Click here	Click here	Click here
TPS65145	Click here	Click here	Click here	Click here	Click here

11.4 Receiving Notification of Documentation Updates

To receive notification of documentation updates, navigate to the device product folder on ti.com. In the upper right corner, click on *Alert me* to register and receive a weekly digest of any product information that has changed. For change details, review the revision history included in any revised document.

11.5 Community Resources

The following links connect to TI community resources. Linked contents are provided "AS IS" by the respective contributors. They do not constitute TI specifications and do not necessarily reflect TI's views; see TI's [Terms of Use](#).

TI E2E™ Online Community *TI's Engineer-to-Engineer (E2E) Community*. Created to foster collaboration among engineers. At e2e.ti.com, you can ask questions, share knowledge, explore ideas and help solve problems with fellow engineers.

Design Support *TI's Design Support* Quickly find helpful E2E forums along with design support tools and contact information for technical support.

11.6 Trademarks

PowerPAD, E2E are trademarks of Texas Instruments.
All other trademarks are the property of their respective owners.

11.7 Electrostatic Discharge Caution



These devices have limited built-in ESD protection. The leads should be shorted together or the device placed in conductive foam during storage or handling to prevent electrostatic damage to the MOS gates.

11.8 Glossary

[SLYZ022](#) — *TI Glossary*.

This glossary lists and explains terms, acronyms, and definitions.

12 Mechanical, Packaging, and Orderable Information

The following pages include mechanical, packaging, and orderable information. This information is the most current data available for the designated devices. This data is subject to change without notice and revision of this document. For browser-based versions of this data sheet, refer to the left-hand navigation.

PACKAGING INFORMATION

Orderable Device	Status (1)	Package Type	Package Drawing	Pins	Package Qty	Eco Plan (2)	Lead/Ball Finish (6)	MSL Peak Temp (3)	Op Temp (°C)	Device Marking (4/5)	Samples
TPS65140PWP	ACTIVE	HTSSOP	PWP	24	60	Green (RoHS & no Sb/Br)	CU NIPDAU	Level-2-260C-1 YEAR	-40 to 85	TPS65140	Samples
TPS65140PWPR	ACTIVE	HTSSOP	PWP	24	2000	Green (RoHS & no Sb/Br)	CU NIPDAU	Level-2-260C-1 YEAR	-40 to 85	TPS65140	Samples
TPS65140RGER	ACTIVE	VQFN	RGE	24	3000	Green (RoHS & no Sb/Br)	CU NIPDAU	Level-2-260C-1 YEAR	-40 to 85	TPS 65140	Samples
TPS65141PWP	ACTIVE	HTSSOP	PWP	24	60	Green (RoHS & no Sb/Br)	CU NIPDAU	Level-2-260C-1 YEAR	-40 to 85	TPS65141	Samples
TPS65141PWPR	ACTIVE	HTSSOP	PWP	24	2000	Green (RoHS & no Sb/Br)	CU NIPDAU	Level-2-260C-1 YEAR	-40 to 85	TPS65141	Samples
TPS65141RGER	ACTIVE	VQFN	RGE	24	3000	Green (RoHS & no Sb/Br)	CU NIPDAU	Level-2-260C-1 YEAR	-40 to 85	TPS 65141	Samples
TPS65145PWP	ACTIVE	HTSSOP	PWP	24	60	Green (RoHS & no Sb/Br)	CU NIPDAU	Level-2-260C-1 YEAR	-40 to 85	TPS65145	Samples
TPS65145PWPR	ACTIVE	HTSSOP	PWP	24	2000	Green (RoHS & no Sb/Br)	CU NIPDAU	Level-2-260C-1 YEAR	-40 to 85	TPS65145	Samples
TPS65145RGER	ACTIVE	VQFN	RGE	24	3000	Green (RoHS & no Sb/Br)	CU NIPDAU	Level-2-260C-1 YEAR	-40 to 85	TPS 65145	Samples

(1) The marketing status values are defined as follows:

ACTIVE: Product device recommended for new designs.

LIFEBUY: TI has announced that the device will be discontinued, and a lifetime-buy period is in effect.

NRND: Not recommended for new designs. Device is in production to support existing customers, but TI does not recommend using this part in a new design.

PREVIEW: Device has been announced but is not in production. Samples may or may not be available.

OBSOLETE: TI has discontinued the production of the device.

(2) **RoHS:** TI defines "RoHS" to mean semiconductor products that are compliant with the current EU RoHS requirements for all 10 RoHS substances, including the requirement that RoHS substance do not exceed 0.1% by weight in homogeneous materials. Where designed to be soldered at high temperatures, "RoHS" products are suitable for use in specified lead-free processes. TI may reference these types of products as "Pb-Free".

RoHS Exempt: TI defines "RoHS Exempt" to mean products that contain lead but are compliant with EU RoHS pursuant to a specific EU RoHS exemption.

Green: TI defines "Green" to mean the content of Chlorine (Cl) and Bromine (Br) based flame retardants meet JS709B low halogen requirements of <=1000ppm threshold. Antimony trioxide based flame retardants must also meet the <=1000ppm threshold requirement.

(3) MSL, Peak Temp. - The Moisture Sensitivity Level rating according to the JEDEC industry standard classifications, and peak solder temperature.

- (4) There may be additional marking, which relates to the logo, the lot trace code information, or the environmental category on the device.
- (5) Multiple Device Markings will be inside parentheses. Only one Device Marking contained in parentheses and separated by a "~" will appear on a device. If a line is indented then it is a continuation of the previous line and the two combined represent the entire Device Marking for that device.
- (6) Lead/Ball Finish - Orderable Devices may have multiple material finish options. Finish options are separated by a vertical ruled line. Lead/Ball Finish values may wrap to two lines if the finish value exceeds the maximum column width.

Important Information and Disclaimer: The information provided on this page represents TI's knowledge and belief as of the date that it is provided. TI bases its knowledge and belief on information provided by third parties, and makes no representation or warranty as to the accuracy of such information. Efforts are underway to better integrate information from third parties. TI has taken and continues to take reasonable steps to provide representative and accurate information but may not have conducted destructive testing or chemical analysis on incoming materials and chemicals. TI and TI suppliers consider certain information to be proprietary, and thus CAS numbers and other limited information may not be available for release.

In no event shall TI's liability arising out of such information exceed the total purchase price of the TI part(s) at issue in this document sold by TI to Customer on an annual basis.

OTHER QUALIFIED VERSIONS OF TPS65140, TPS65145 :

- Automotive: [TPS65140-Q1](#), [TPS65145-Q1](#)

NOTE: Qualified Version Definitions:

- Automotive - Q100 devices qualified for high-reliability automotive applications targeting zero defects

TAPE AND REEL INFORMATION



QUADRANT ASSIGNMENTS FOR PIN 1 ORIENTATION IN TAPE



*All dimensions are nominal

Device	Package Type	Package Drawing	Pins	SPQ	Reel Diameter (mm)	Reel Width W1 (mm)	A0 (mm)	B0 (mm)	K0 (mm)	P1 (mm)	W (mm)	Pin1 Quadrant
TPS65140PWPR	HTSSOP	PWP	24	2000	330.0	16.4	6.95	8.3	1.6	8.0	16.0	Q1
TPS65140RGER	VQFN	RGE	24	3000	330.0	12.4	4.25	4.25	1.15	8.0	12.0	Q2
TPS65141PWPR	HTSSOP	PWP	24	2000	330.0	16.4	6.95	8.3	1.6	8.0	16.0	Q1
TPS65141RGER	VQFN	RGE	24	3000	330.0	12.4	4.25	4.25	1.15	8.0	12.0	Q2
TPS65145PWPR	HTSSOP	PWP	24	2000	330.0	16.4	6.95	8.3	1.6	8.0	16.0	Q1
TPS65145RGER	VQFN	RGE	24	3000	330.0	12.4	4.25	4.25	1.15	8.0	12.0	Q2

TAPE AND REEL BOX DIMENSIONS

*All dimensions are nominal

Device	Package Type	Package Drawing	Pins	SPQ	Length (mm)	Width (mm)	Height (mm)
TPS65140PWPR	HTSSOP	PWP	24	2000	350.0	350.0	43.0
TPS65140RGER	VQFN	RGE	24	3000	367.0	367.0	35.0
TPS65141PWPR	HTSSOP	PWP	24	2000	350.0	350.0	43.0
TPS65141RGER	VQFN	RGE	24	3000	367.0	367.0	35.0
TPS65145PWPR	HTSSOP	PWP	24	2000	350.0	350.0	43.0
TPS65145RGER	VQFN	RGE	24	3000	367.0	367.0	35.0

GENERIC PACKAGE VIEW

PWP 24

PowerPAD™ TSSOP - 1.2 mm max height

4.4 x 7.6, 0.65 mm pitch

PLASTIC SMALL OUTLINE

This image is a representation of the package family, actual package may vary.
Refer to the product data sheet for package details.

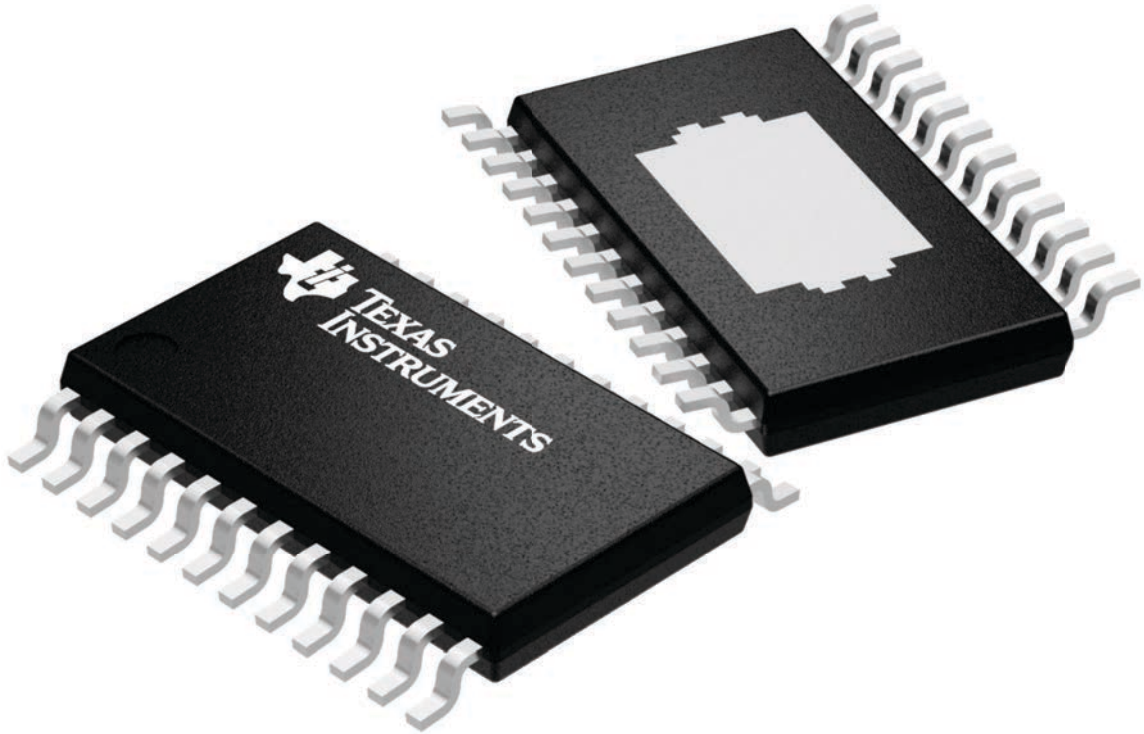

4224742/B

PWP0024B



PACKAGE OUTLINE

PowerPAD™ TSSOP - 1.2 mm max height

PLASTIC SMALL OUTLINE

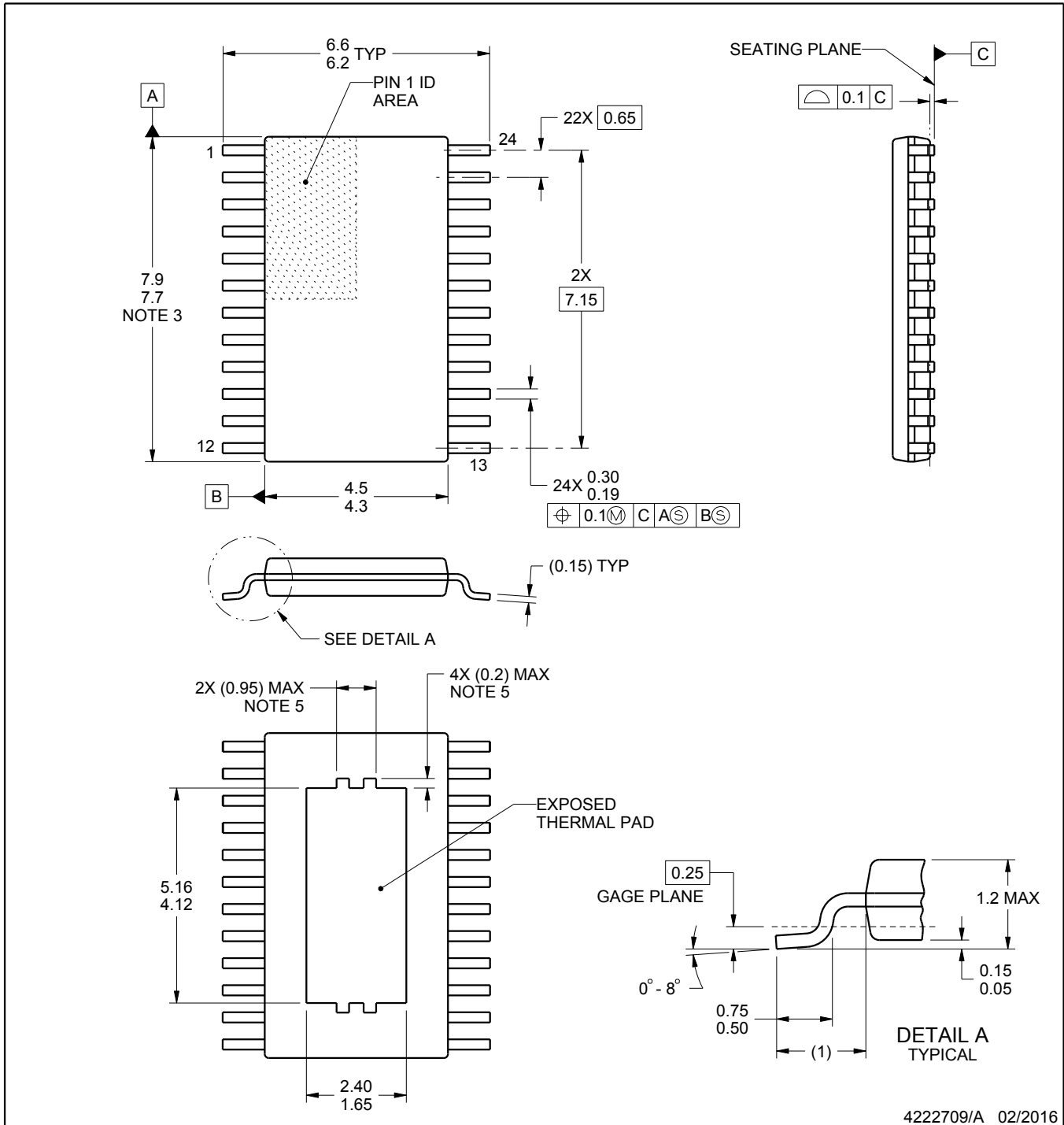

4222709/A 02/2016

NOTES:

PowerPAD is a trademark of Texas Instruments.

1. All linear dimensions are in millimeters. Any dimensions in parenthesis are for reference only. Dimensioning and tolerancing per ASME Y14.5M.
2. This drawing is subject to change without notice.
3. This dimension does not include mold flash, protrusions, or gate burrs. Mold flash, protrusions, or gate burrs shall not exceed 0.15 mm per side.
4. Reference JEDEC registration MO-153.
5. Features may not be present and may vary.

EXAMPLE BOARD LAYOUT

PWP0024B

PowerPAD™ TSSOP - 1.2 mm max height

PLASTIC SMALL OUTLINE

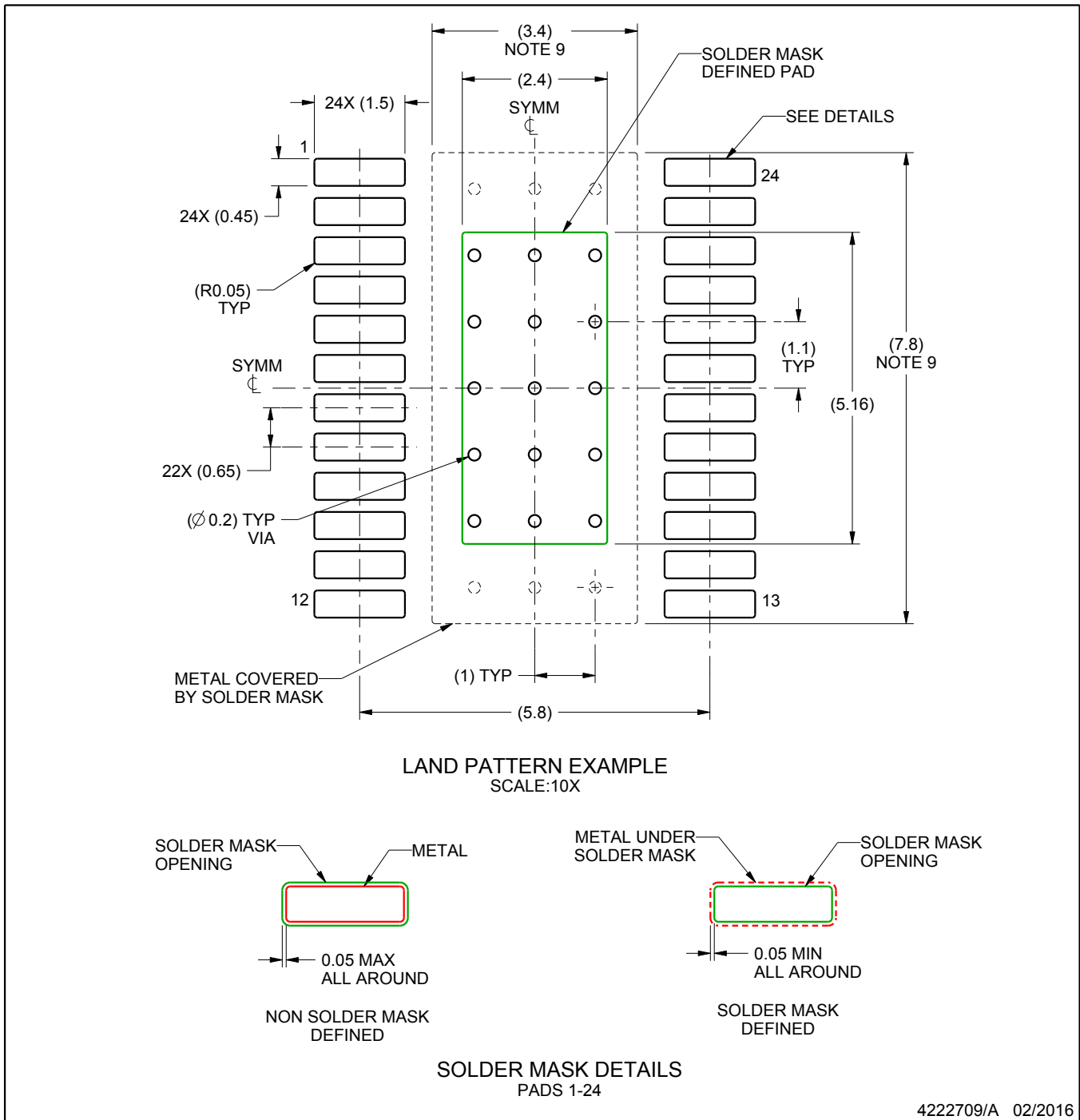

NOTES: (continued)

6. Publication IPC-7351 may have alternate designs.
7. Solder mask tolerances between and around signal pads can vary based on board fabrication site.
8. This package is designed to be soldered to a thermal pad on the board. For more information, see Texas Instruments literature numbers SLMA002 (www.ti.com/lit/slma002) and SLMA004 (www.ti.com/lit/slma004).
9. Size of metal pad may vary due to creepage requirement.

EXAMPLE STENCIL DESIGN

PWP0024B

PowerPAD™ TSSOP - 1.2 mm max height

PLASTIC SMALL OUTLINE

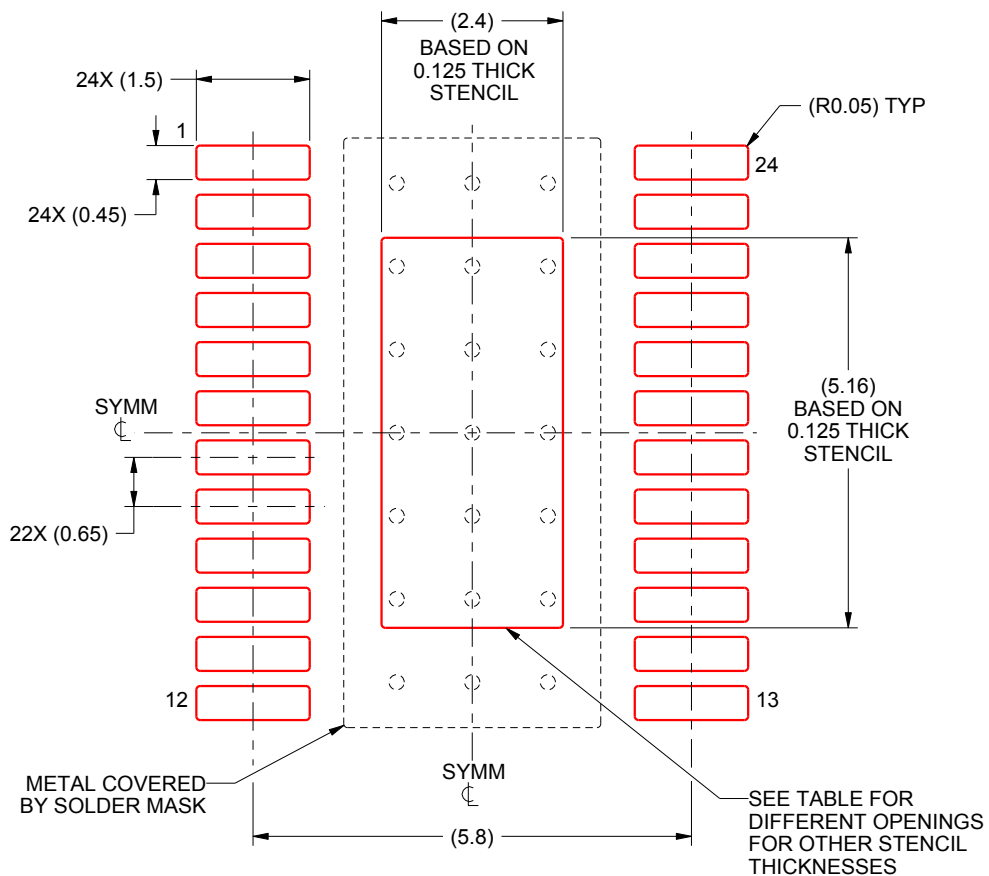

SOLDER PASTE EXAMPLE
 EXPOSED PAD
 100% PRINTED SOLDER COVERAGE BY AREA
 SCALE:10X

STENCIL THICKNESS	SOLDER STENCIL OPENING
0.1	2.68 X 5.77
0.125	2.4 X 5.16 (SHOWN)
0.15	2.19 X 4.71
0.175	2.03 X 4.36

4222709/A 02/2016

NOTES: (continued)

- 10. Laser cutting apertures with trapezoidal walls and rounded corners may offer better paste release. IPC-7525 may have alternate design recommendations.
- 11. Board assembly site may have different recommendations for stencil design.

GENERIC PACKAGE VIEW

RGE 24

VQFN - 1 mm max height

PLASTIC QUAD FLATPACK - NO LEAD

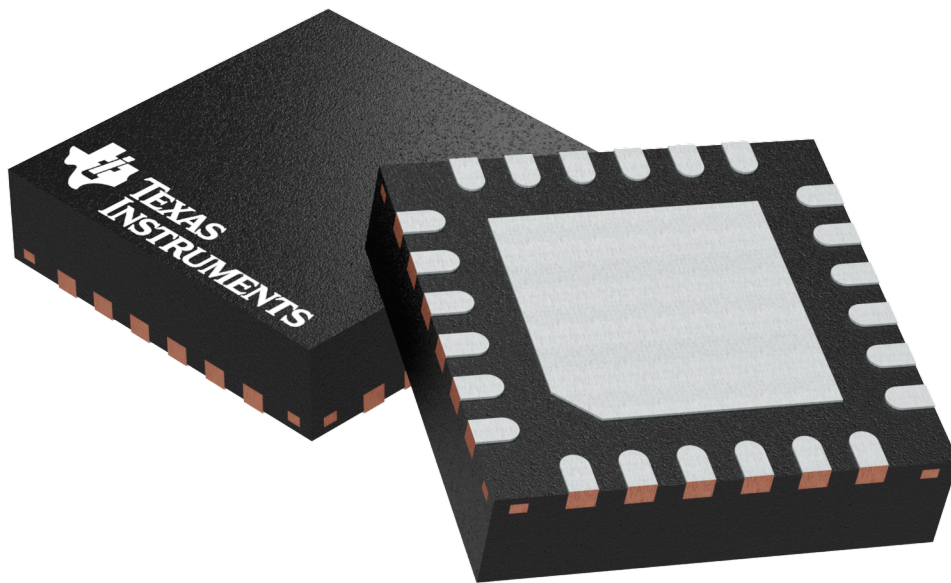

Images above are just a representation of the package family, actual package may vary.
Refer to the product data sheet for package details.

4204104/H

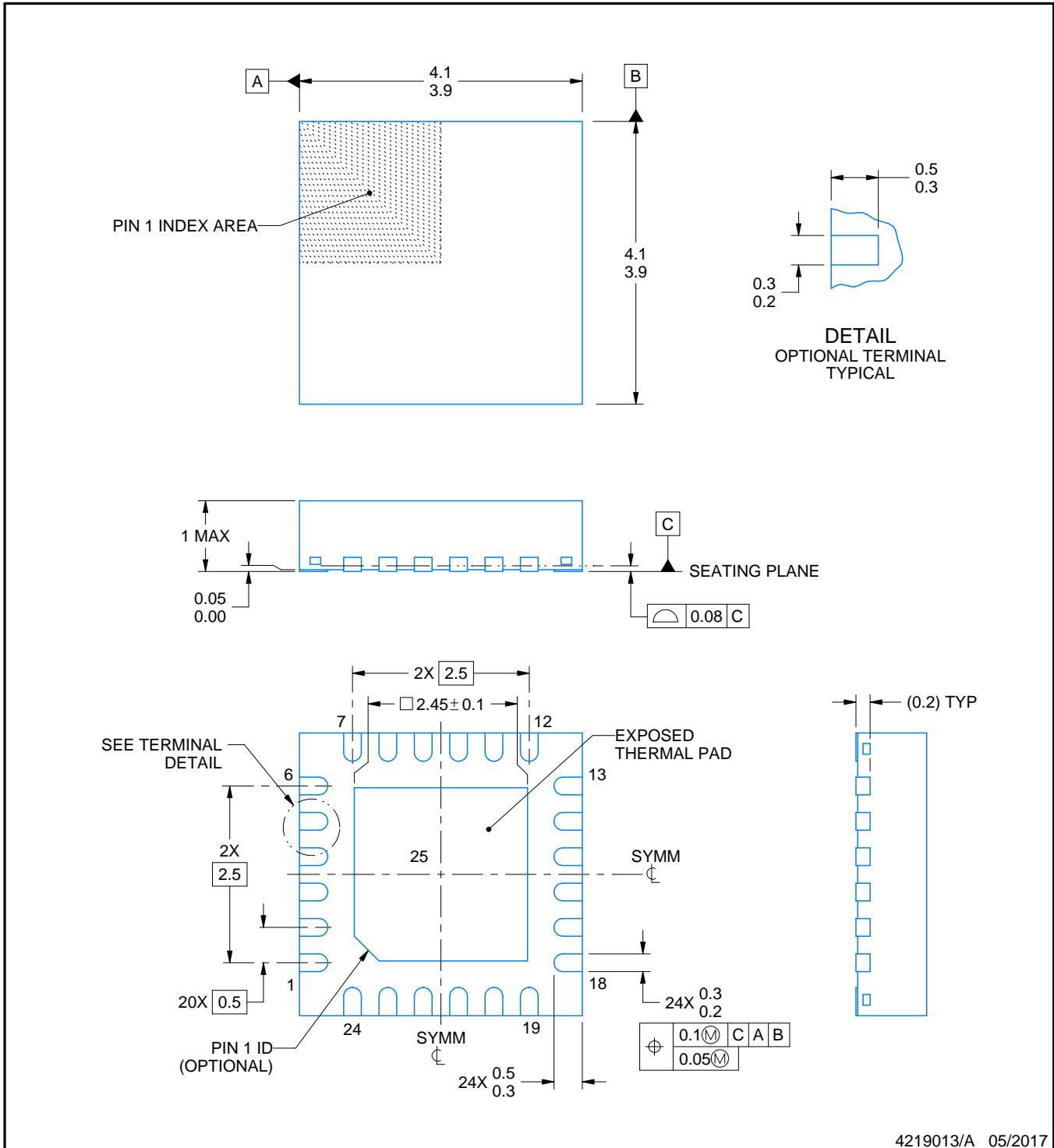
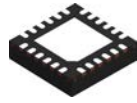

4219013/A 05/2017

NOTES:

1. All linear dimensions are in millimeters. Any dimensions in parenthesis are for reference only. Dimensioning and tolerancing per ASME Y14.5M.
2. This drawing is subject to change without notice.
3. The package thermal pad must be soldered to the printed circuit board for thermal and mechanical performance.

EXAMPLE STENCIL DESIGN

RGE0024B

VQFN - 1 mm max height

PLASTIC QUAD FLATPACK - NO LEAD

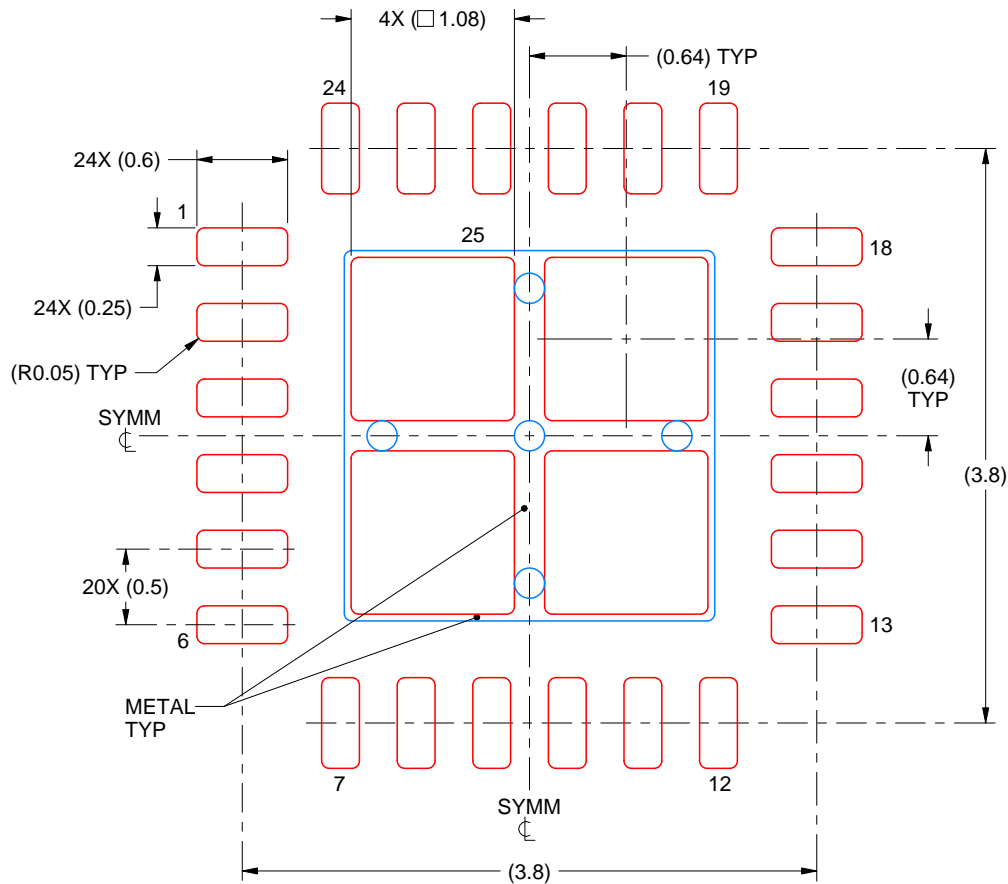

SOLDER PASTE EXAMPLE
BASED ON 0.125 mm THICK STENCIL

EXPOSED PAD 25
78% PRINTED SOLDER COVERAGE BY AREA UNDER PACKAGE
SCALE:20X

4219013/A 05/2017

NOTES: (continued)

6. Laser cutting apertures with trapezoidal walls and rounded corners may offer better paste release. IPC-7525 may have alternate design recommendations.

IMPORTANT NOTICE AND DISCLAIMER

TI PROVIDES TECHNICAL AND RELIABILITY DATA (INCLUDING DATASHEETS), DESIGN RESOURCES (INCLUDING REFERENCE DESIGNS), APPLICATION OR OTHER DESIGN ADVICE, WEB TOOLS, SAFETY INFORMATION, AND OTHER RESOURCES "AS IS" AND WITH ALL FAULTS, AND DISCLAIMS ALL WARRANTIES, EXPRESS AND IMPLIED, INCLUDING WITHOUT LIMITATION ANY IMPLIED WARRANTIES OF MERCHANTABILITY, FITNESS FOR A PARTICULAR PURPOSE OR NON-INFRINGEMENT OF THIRD PARTY INTELLECTUAL PROPERTY RIGHTS.

These resources are intended for skilled developers designing with TI products. You are solely responsible for (1) selecting the appropriate TI products for your application, (2) designing, validating and testing your application, and (3) ensuring your application meets applicable standards, and any other safety, security, or other requirements. These resources are subject to change without notice. TI grants you permission to use these resources only for development of an application that uses the TI products described in the resource. Other reproduction and display of these resources is prohibited. No license is granted to any other TI intellectual property right or to any third party intellectual property right. TI disclaims responsibility for, and you will fully indemnify TI and its representatives against, any claims, damages, costs, losses, and liabilities arising out of your use of these resources.

TI's products are provided subject to TI's Terms of Sale (www.ti.com/legal/termsofsale.html) or other applicable terms available either on ti.com or provided in conjunction with such TI products. TI's provision of these resources does not expand or otherwise alter TI's applicable warranties or warranty disclaimers for TI products.

Mailing Address: Texas Instruments, Post Office Box 655303, Dallas, Texas 75265
Copyright © 2019, Texas Instruments Incorporated

Looking for pricing, stock, or lifecycle information?

Click below to explore more details on WIN SOURCE:

 [View TPS65145RGER](#) on WIN SOURCE

 [Texas Instruments](#) Information

Optimize Your Supply Chain with WIN SOURCE Solutions

-  Global Sourcing Solution
-  Obsolete Management
-  Cost Control Management
-  Shortage Management
-  Alternative Solution
-  Excess Inventory Management