



# THE DATASHEET OF RFG60P05E



**60A, 50V, 0.030 Ohm, ESD Rated,  
P-Channel Power MOSFET**

This is a P-Channel power MOSFET manufactured using the MegaFET process. This process, which uses feature sizes approaching those of LSI circuits, gives optimum utilization of silicon, resulting in outstanding performance. It was designed for use in applications such as switching regulators, switching converters, motor drivers, and relay drivers. This type can be operated directly from integrated circuits.

Formerly developmental type TA09835.

**Ordering Information**

PART NUMBER	PACKAGE	BRAND
RFG60P05E	TO-247	RFG60P05E

NOTE: When ordering, use the entire part number.

**Features**

- 60A, 50V
- $r_{DS(ON)} = 0.030\Omega$
- Temperature Compensating PSPICE® Model
- 2kV ESD Rated
- Peak Current vs Pulse Width Curve
- UIS Rating Curve
- 175°C Operating Temperature
- Related Literature
  - TB334 "Guidelines for Soldering Surface Mount Components to PC Boards"

**Symbol**

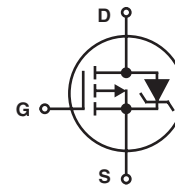

**Packaging**

JEDEC STYLE TO-247

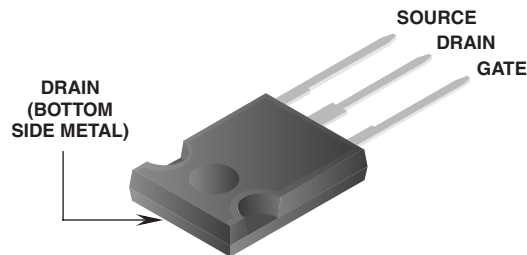

# RFG60P05E

## Absolute Maximum Ratings $T_C = 25^\circ\text{C}$ , Unless Otherwise Specified

	RFG60P05E	UNITS
Drain to Source Breakdown Voltage (Note 1)	-50	V
Drain to Gate Voltage ( $R_{GS} = 20\text{k}\Omega$ ) (Note 1)	-50	V
Gate to Source Voltage	$\pm 20$	V
Continuous Drain Current	60	A
Pulsed Drain Current (Note 3) (Figure 5)	Refer to Peak Current Curve	
Power Dissipation	215	W
Derate above $25^\circ\text{C}$ .	1.43	W/ $^\circ\text{C}$
Single Pulse Avalanche Rating (Figure 6)	Refer to UIS Curve	W/ $^\circ\text{C}$
Electrostatic Discharge Rating MIL-STD-883, Category B(2)	2	kV
Operating and Storage Temperature	-55 to 175	$^\circ\text{C}$
Maximum Temperature for Soldering		
Leads at 0.063in (1.6mm) from Case for 10s	300	$^\circ\text{C}$
Package Body for 10s, See Techbrief 334	260	$^\circ\text{C}$

CAUTION: Stresses above those listed in "Absolute Maximum Ratings" may cause permanent damage to the device. This is a stress only rating and operation of the device at these or any other conditions above those indicated in the operational sections of this specification is not implied.

### NOTE:

- $T_J = 25^\circ\text{C}$  to  $150^\circ\text{C}$ .

## Electrical Specifications $T_C = 25^\circ\text{C}$ , Unless Otherwise Specified

PARAMETER	SYMBOL	TEST CONDITIONS	MIN	TYP	MAX	UNITS
Drain to Source Breakdown Voltage	$BV_{DSS}$	$I_D = 250\mu\text{A}$ , $V_{GS} = 0\text{V}$	-50	-	-	V
Gate Threshold Voltage	$V_{GS(TH)}$	$V_{GS} = V_{DS}$ , $I_D = 250\mu\text{A}$	-2	-	-4	V
Zero Gate Voltage Drain Current	$I_{DSS}$	$V_{DS} = -50\text{V}$ , $V_{GS} = 0\text{V}$	-	-	-1	$\mu\text{A}$
		$V_{DS} = 0.8 \times \text{Rated } BV_{DSS}$ , $T_C = 150^\circ\text{C}$	-	-	-25	$\mu\text{A}$
Gate to Source Leakage Current	$I_{GSS}$	$V_{GS} = \pm 20\text{V}$	-	-	$\pm 100$	nA
Drain to Source On Resistance (Note 2)	$r_{DS(ON)}$	$I_D = 60\text{A}$ , $V_{GS} = -10\text{V}$ (Figure 9)	-	-	0.030	$\Omega$
Turn-On Time	$t_{(ON)}$	$V_{DD} = -25\text{V}$ , $I_D = 30\text{A}$ , $R_L = 0.83\Omega$ , $V_{GS} = -10\text{V}$ , $R_{GS} = 2.5\Omega$ (Figure 13)	-	-	125	ns
Turn-On Delay Time	$t_{d(ON)}$		-	20	-	ns
Rise Time	$t_r$		-	60	-	ns
Turn-Off Delay Time	$t_{d(OFF)}$		-	65	-	ns
Fall Time	$t_f$		-	20	-	ns
Turn-Off Time	$t_{(OFF)}$		-	-	-	125
Total Gate Charge	$Q_g(\text{TOT})$	$V_{GS} = 0\text{V}$ to $-20\text{V}$	-	-	450	nC
Gate Charge at 10V	$Q_g(-10)$	$V_{GS} = 0\text{V}$ to $-10\text{V}$				
Threshold Gate Charge	$Q_g(\text{TH})$	$V_{GS} = 0\text{V}$ to $-2\text{V}$				
Input Capacitance	$C_{ISS}$	$V_{DS} = -25\text{V}$ , $V_{GS} = 0\text{V}$ , $f = 1\text{MHz}$ (Figure 12)	-	7200	-	pF
Output Capacitance	$C_{OSS}$		-	1700	-	pF
Reverse Transfer Capacitance	$C_{RSS}$		-	325	-	pF
Thermal Resistance, Junction to Case	$R_{\theta JC}$		-	-	0.70	$^\circ\text{C}/\text{W}$
Thermal Resistance, Junction to Ambient	$R_{\theta JA}$		-	-	30	$^\circ\text{C}/\text{W}$

## Source to Drain Diode Specifications

PARAMETER	SYMBOL	TEST CONDITIONS	MIN	TYP	MAX	UNITS
Source to Drain Diode Voltage (Note 2)	$V_{SD}$	$I_{SD} = -60\text{A}$	-	-	-1.75	V
Diode Reverse Recovery Time	$t_{RR}$	$I_{SD} = -60\text{A}$ , $dI_{SD}/dt = 100\text{A}/\mu\text{s}$	-	-	200	ns

### NOTE:

- Pulse test: pulse width  $\leq 300\mu\text{s}$  maximum, duty cycle  $\leq 2\%$ .
- Repetitive rating: pulse width limited by maximum junction temperature. See Transient Thermal Impedance curve (Figure 3).

Typical Performance Curves Unless Otherwise Specified

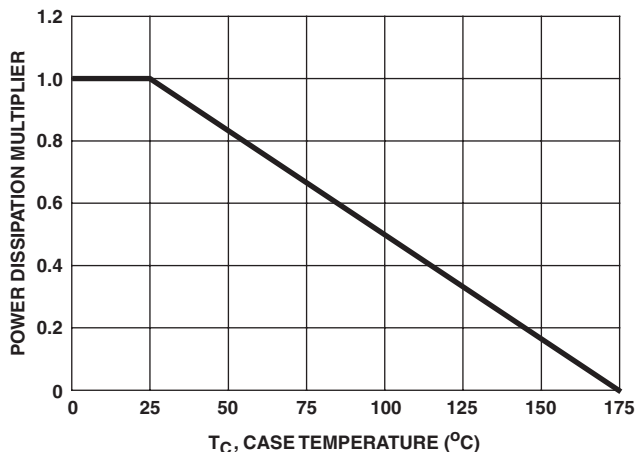

FIGURE 1. NORMALIZED POWER DISSIPATION vs CASE TEMPERATURE

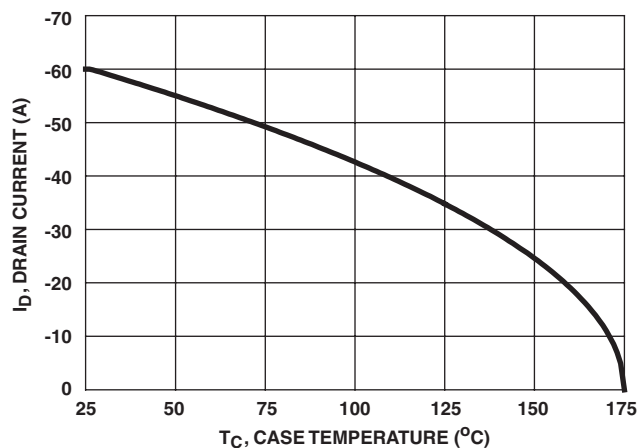

FIGURE 2. MAXIMUM CONTINUOUS DRAIN CURRENT vs CASE TEMPERATURE

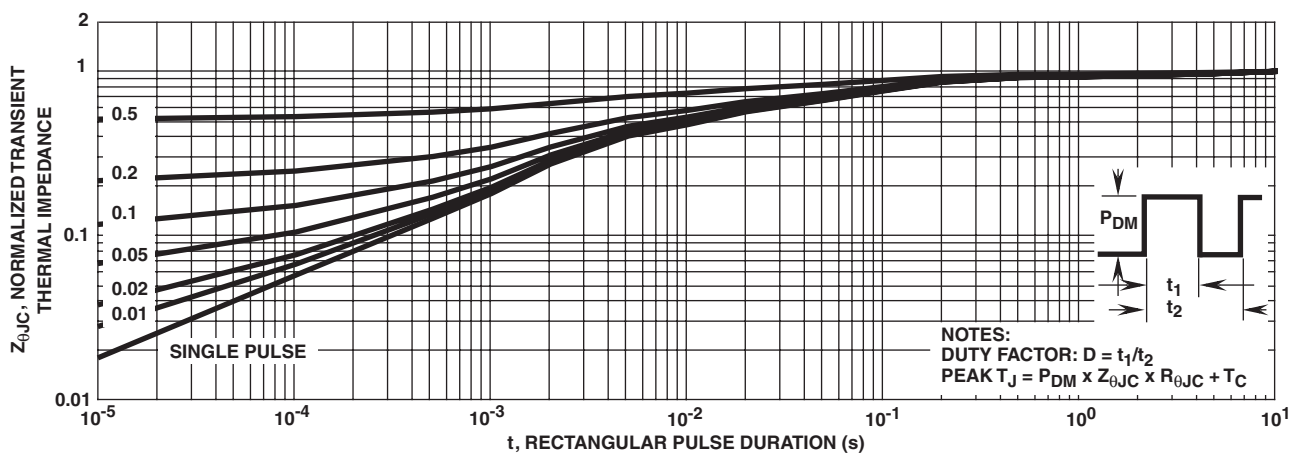

FIGURE 3. NORMALIZED MAXIMUM TRANSIENT THERMAL IMPEDANCE

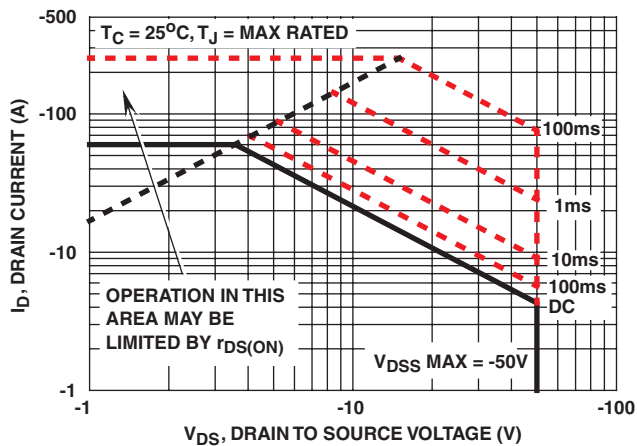

FIGURE 4. FORWARD BIAS SAFE OPERATING AREA

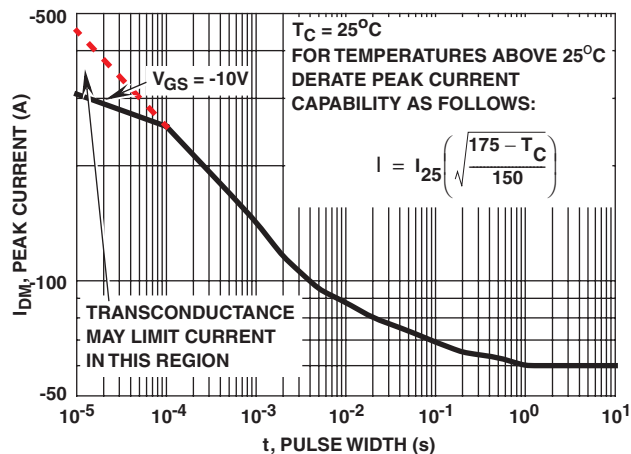
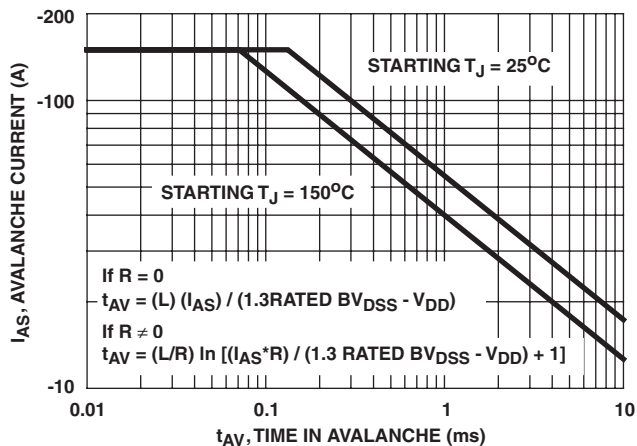
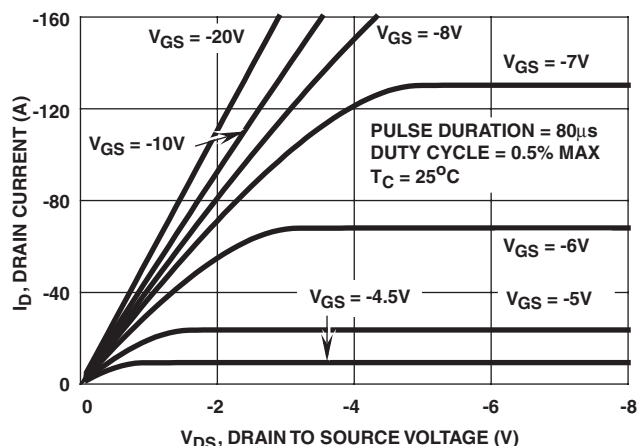

FIGURE 5. PEAK CURRENT CAPABILITY

Typical Performance Curves Unless Otherwise Specified (Continued)



NOTE: Refer to Fairchild Application Notes AN9321 and AN9322.  
**FIGURE 6. UNCLAMPED INDUCTIVE SWITCHING CAPABILITY**



**FIGURE 7. SATURATION CHARACTERISTICS**

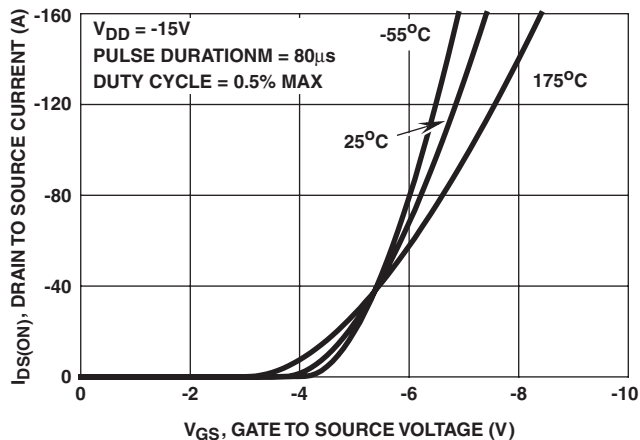

**FIGURE 8. TRANSFER CHARACTERISTICS**

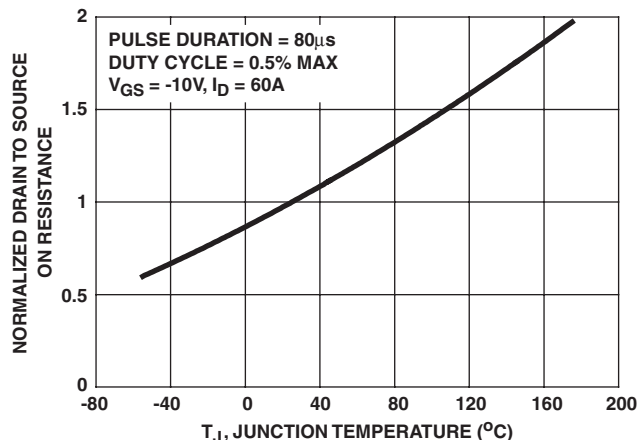

**FIGURE 9. NORMALIZED DRAIN TO SOURCE ON RESISTANCE vs JUNCTION TEMPERATURE**

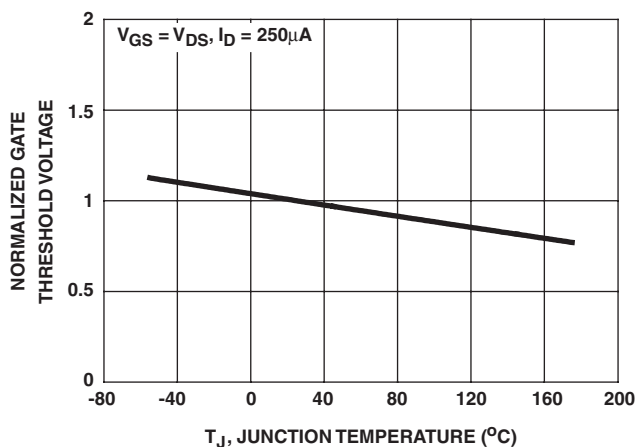

**FIGURE 10. NORMALIZED GATE THRESHOLD VOLTAGE vs JUNCTION TEMPERATURE**

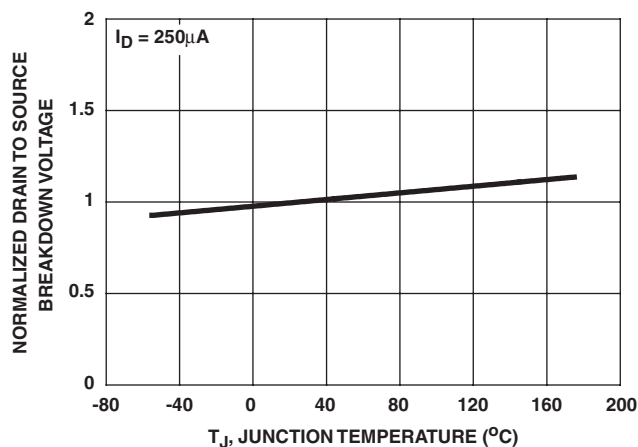

**FIGURE 11. NORMALIZED DRAIN TO SOURCE BREAKDOWN VOLTAGE vs JUNCTION TEMPERATURE**

**Typical Performance Curves** Unless Otherwise Specified (Continued)

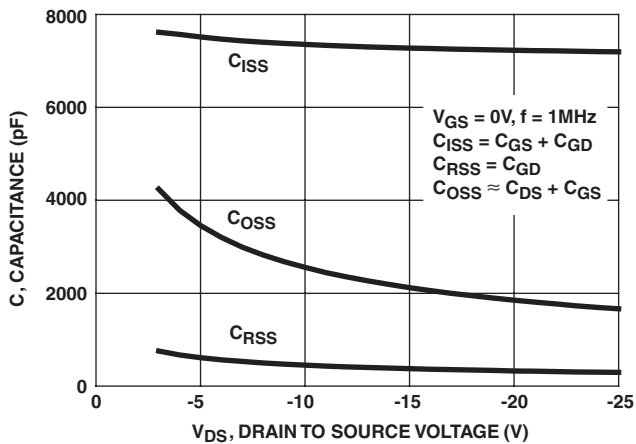
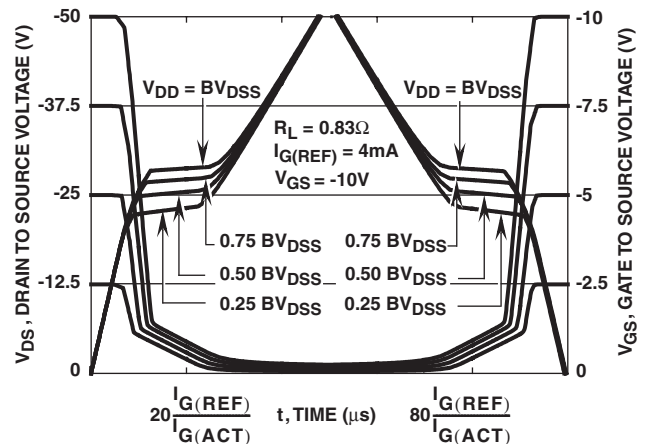

FIGURE 12. CAPACITANCE vs DRAIN TO SOURCE VOLTAGE



NOTE: Refer to Fairchild Application Notes AN7254 and AN7260.

FIGURE 13. NORMALIZED SWITCHING WAVEFORMS FOR CONSTANT GATE CURRENT

**Test Circuits and Waveforms**

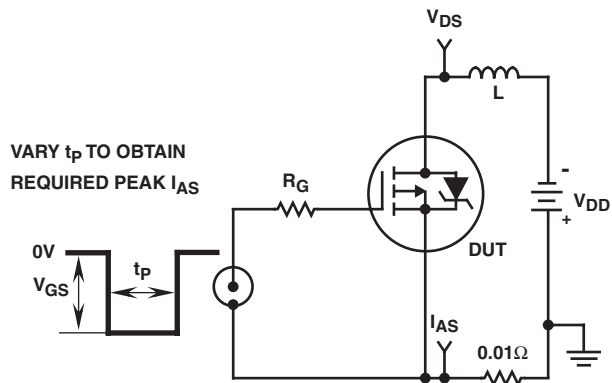

FIGURE 14. UNCLAMPED ENERGY TEST CIRCUIT

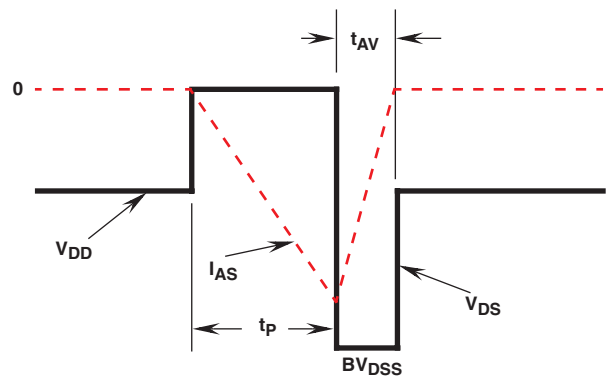

FIGURE 15. UNCLAMPED ENERGY WAVEFORMS

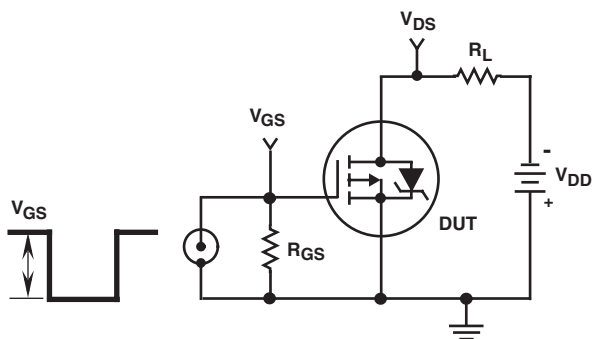

FIGURE 16. SWITCHING TIME TEST CIRCUIT

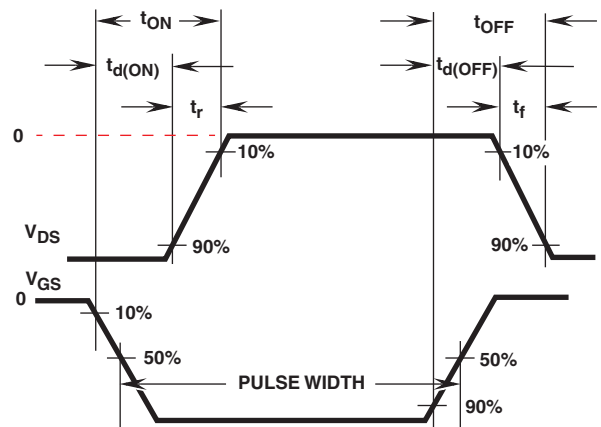

FIGURE 17. RESISTIVE SWITCHING WAVEFORMS

Test Circuits and Waveforms (Continued)

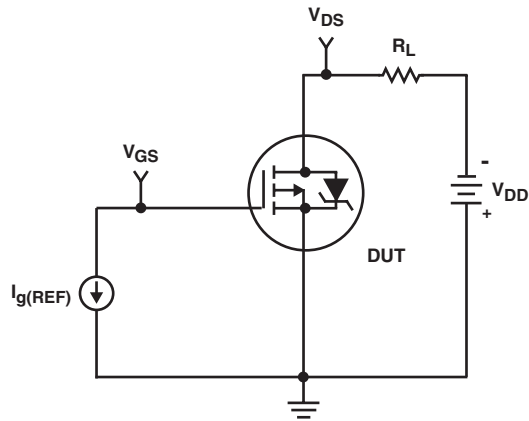

FIGURE 18. GATE CHARGE TEST CIRCUIT

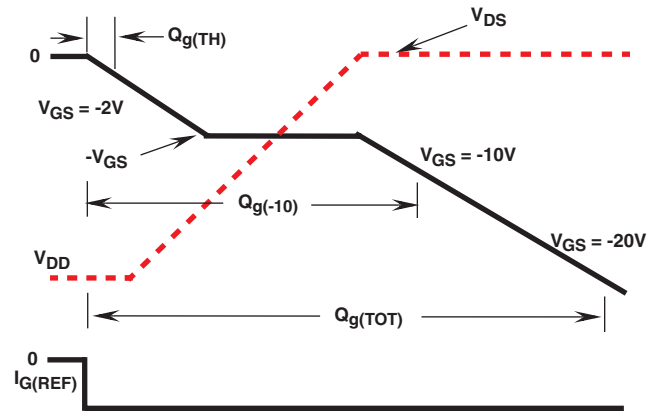

FIGURE 19. GATE CHARGE WAVEFORMS

# RFG60P05E

## PSPICE Electrical Model

.SUBCKT RFG60P05E 2 1 3;

REV 9/20/94

CA 12 8 1.01e-8  
 CB 15 14 1.05e-8  
 CIN 6 8 6.9e-9

DBODY 5 7 DBDMOD  
 DBREAK 7 11 DBKMOD  
 DPLCAP 10 6 DPLCAPMOD

EBREAK 5 11 17 18 -76.35  
 EDS 14 8 5 8 1  
 EGS 13 8 6 8 1  
 ESG 5 10 8 6 1  
 EVTO 20 6 8 18 1

IT 8 17 1

LDRAIN 2 5 1e-9  
 LGATE 1 9 7.9e-9  
 LSOURCE 3 7 4.18e-9

MOS1 16 6 8 8 MOSMOD M = 0.99  
 MOS2 16 21 8 8 MOSMOD M = 0.01

RBREAK 17 18 RBKMOD 1  
 RDRAIN 5 16 RDSMOD 12.83e-3  
 RGATE 9 20 1.5  
 RIN 6 8 1e9  
 RSOURCE 8 7 RDSMOD 3.25e-3  
 RVTO 18 19 RVTOMOD 1

S1A 6 12 13 8 S1AMOD  
 S1B 13 12 13 8 S1BMOD  
 S2A 6 15 14 13 S2AMOD  
 S2B 13 15 14 13 S2BMOD

VBAT 8 19 DC 1  
 VTO 21 6 -0.83

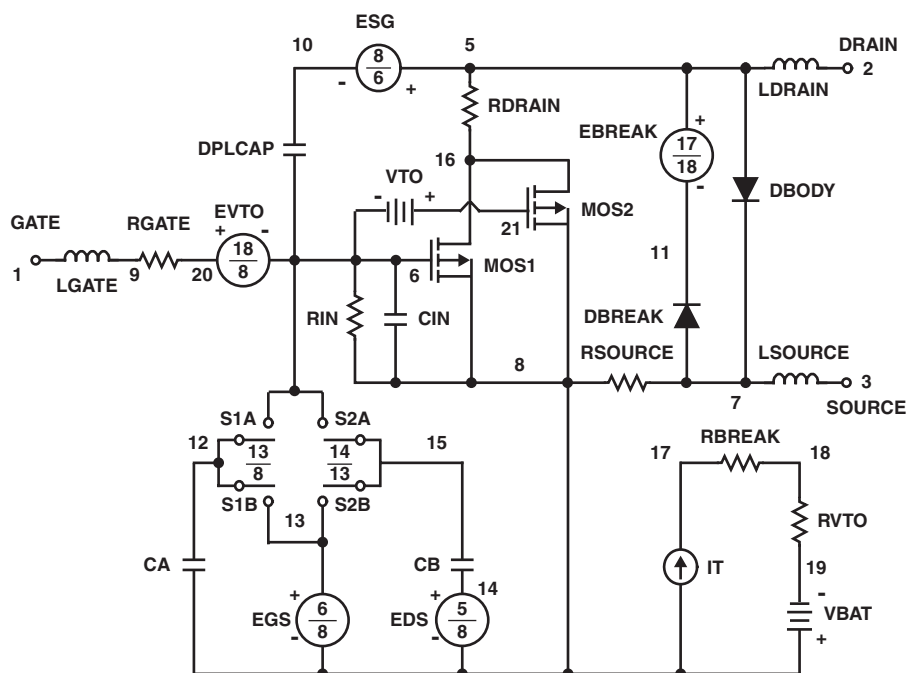

.MODEL DBDMOD D (IS = 1.24e-12 RS = 4.72e-3 TRS1 = 1.43e-3 TRS2 = -4.91e-7 CJO = 6.98e-9 TT = 1.5e-7)  
 .MODEL DBKMOD D (RS = 1.11e-1 TRS1 = 1.34e-3 TRS2 = 4.46e-12)  
 .MODEL DPLCAPMOD D (CJO = 15e-10 IS = 1e-30 N = 10)  
 .MODEL MOSMOD PMOS (VTO = -3.71 KP = 31.5 IS = 1e-30 N = 10 TOX = 1 L = 1u W = 1u)  
 .MODEL RBKMOD RES (TC1 = 9.42e-4 TC2 = 0)  
 .MODEL RDSMOD RES (TC1 = 5.85e-3 TC2 = 7.69e-6)  
 .MODEL RVTOMOD RES (TC1 = -3.39e-3 TC2 = 1.07e-6)  
 .MODEL S1AMOD VSWITCH (RON = 1e-5 ROFF = 0.1 VON = 4.6 VOFF = 2.6)  
 .MODEL S1BMOD VSWITCH (RON = 1e-5 ROFF = 0.1 VON = 2.6 VOFF = 4.6)  
 .MODEL S2AMOD VSWITCH (RON = 1e-5 ROFF = 0.1 VON = 1.16 VOFF = -3.84)  
 .MODEL S2BMOD VSWITCH (RON = 1e-5 ROFF = 0.1 VON = -3.84 VOFF = 1.16)

.ENDS

For further discussion of the PSPICE model, consult **A New PSPICE Sub-circuit for the Power MOSFET Featuring Global Temperature Options**; written by William J. Hepp and C. Frank Wheatley.

## TRADEMARKS

The following are registered and unregistered trademarks Fairchild Semiconductor owns or is authorized to use and is not intended to be an exhaustive list of all such trademarks.

ACE <sub>x</sub> <sup>TM</sup>	FAST <sup>®</sup>	OPTOLOGIC <sup>TM</sup>	SMART START <sup>TM</sup>	VCX <sup>TM</sup>
Bottomless <sup>TM</sup>	FAST <sub>r</sub> <sup>TM</sup>	OPTOPLANAR <sup>TM</sup>	STAR*POWER <sup>TM</sup>	
CoolFET <sup>TM</sup>	FRFET <sup>TM</sup>	PACMAN <sup>TM</sup>	Stealth <sup>TM</sup>	
CROSSVOLT <sup>TM</sup>	GlobalOptoisolator <sup>TM</sup>	POP <sup>TM</sup>	SuperSOT <sup>TM</sup> -3	
DenseTrench <sup>TM</sup>	GTO <sup>TM</sup>	Power247 <sup>TM</sup>	SuperSOT <sup>TM</sup> -6	
DOMET <sup>TM</sup>	HiSeC <sup>TM</sup>	PowerTrench <sup>®</sup>	SuperSOT <sup>TM</sup> -8	
EcoSPARK <sup>TM</sup>	ISOPLANAR <sup>TM</sup>	QFET <sup>TM</sup>	SyncFET <sup>TM</sup>	
E <sup>2</sup> CMOS <sup>TM</sup>	LittleFET <sup>TM</sup>	QS <sup>TM</sup>	TinyLogic <sup>TM</sup>	
EnSigna <sup>TM</sup>	MicroFET <sup>TM</sup>	QT Optoelectronics <sup>TM</sup>	TruTranslation <sup>TM</sup>	
FACT <sup>TM</sup>	MicroPak <sup>TM</sup>	Quiet Series <sup>TM</sup>	UHC <sup>TM</sup>	
FACT Quiet Series <sup>TM</sup>	MICROWIRE <sup>TM</sup>	SILENT SWITCHER <sup>®</sup>	UltraFET <sup>®</sup>	

STAR\*POWER is used under license

## DISCLAIMER

FAIRCHILD SEMICONDUCTOR RESERVES THE RIGHT TO MAKE CHANGES WITHOUT FURTHER NOTICE TO ANY PRODUCTS HEREIN TO IMPROVE RELIABILITY, FUNCTION OR DESIGN. FAIRCHILD DOES NOT ASSUME ANY LIABILITY ARISING OUT OF THE APPLICATION OR USE OF ANY PRODUCT OR CIRCUIT DESCRIBED HEREIN; NEITHER DOES IT CONVEY ANY LICENSE UNDER ITS PATENT RIGHTS, NOR THE RIGHTS OF OTHERS.

## LIFE SUPPORT POLICY

FAIRCHILD'S PRODUCTS ARE NOT AUTHORIZED FOR USE AS CRITICAL COMPONENTS IN LIFE SUPPORT DEVICES OR SYSTEMS WITHOUT THE EXPRESS WRITTEN APPROVAL OF FAIRCHILD SEMICONDUCTOR CORPORATION.

As used herein:

1. Life support devices or systems are devices or systems which, (a) are intended for surgical implant into the body, or (b) support or sustain life, or (c) whose failure to perform when properly used in accordance with instructions for use provided in the labeling, can be reasonably expected to result in significant injury to the user.
2. A critical component is any component of a life support device or system whose failure to perform can be reasonably expected to cause the failure of the life support device or system, or to affect its safety or effectiveness.



## PRODUCT STATUS DEFINITIONS

### Definition of Terms

Datasheet Identification	Product Status	Definition
Advance Information	Formative or In Design	This datasheet contains the design specifications for product development. Specifications may change in any manner without notice.
Preliminary	First Production	This datasheet contains preliminary data, and supplementary data will be published at a later date. Fairchild Semiconductor reserves the right to make changes at any time without notice in order to improve design.
No Identification Needed	Full Production	This datasheet contains final specifications. Fairchild Semiconductor reserves the right to make changes at any time without notice in order to improve design.
Obsolete	Not In Production	This datasheet contains specifications on a product that has been discontinued by Fairchild semiconductor. The datasheet is printed for reference information only.

## Looking for pricing, stock, or lifecycle information?

Click below to explore more details on WIN SOURCE:

-  [View RFG60P05E on WIN SOURCE](#)
-  [Fairchild/ON Semiconductor Information](#)

## Optimize Your Supply Chain with WIN SOURCE Solutions

-  Global Sourcing Solution
-  Obsolete Management
-  Cost Control Management
-  Shortage Management
-  Alternative Solution
-  Excess Inventory Management