



**THE DATASHEET OF  
BQ500414QRGZTQ1**



## bq500414Q Automotive, Free Positioning, Qi Compliant Wireless Power Transmitter Manager

### 1 Features

- Expanded Free Positioning Using Three Coil Transmit Array
- AEC-Q100 Qualified for Automotive Applications
- Conforms to Wireless Power Consortium (WPC) A6 Transmitter Type Specification
- I<sup>2</sup>C Interface to Enable Control and Communication With Host Controllers, that is Read Tx and Rx Stats, Start Tx, and Shift Tx Operating Frequency
- WPC v1.1 Compliant, Including Improved Foreign Object Detection (FOD) Method
- Enhanced Parasitic Metal Object Detection (PMOD) for WPC v1.0 Receivers Protection
- Digital Demodulation Reduces Components
- Over-Current Protection
- LED Indication of Charging State and Fault Status

### 2 Applications

- WPC 1.1 Wireless Chargers:
  - In Cars and Other Vehicle Accessories
  - Qi-Certified Smart Phones and Other Handhelds
  - Industrial and Medical Applications
- See [www.ti.com/wirelesspower](http://www.ti.com/wirelesspower) for More Information on TI's Wireless Charging Solutions

### 3 Description

The bq500414Q is an AEC-Q100 qualified free-positioning digital wireless power controller designed for automotive applications. It integrates all functions required to control wireless power transfer to a WPC compliant receiver. It is WPC v1.1 ready and designed for 12-V systems; however, the bq500414Q is applicable to other supply voltages. The bq500414Q *pings* the surrounding environment for WPC compliant devices to be powered. Once a WPC compliant device is detected, the bq500414Q reads the packet feedback from the powered device and manages the power transfer. A charging area of 70-mm x 20-mm provides flexible receiver placement on a transmitter pad. The bq500414Q supports both Parasitic Metal Object Detection (PMOD) and Foreign Object Detection (FOD) by continuously monitoring the transmitted and received power of the system, protecting the device from over heating. Should any abnormal condition develop during power transfer, the bq500414Q handles it and provides fault indicator outputs. Comprehensive protection features provide a robust design to protect the system in all receiver placements.

The bq500414Q is available in an area saving 48-pin, 7-mm x 7-mm VQFN package and operates over a temperature range from -40°C to 85°C.

#### Device Information<sup>(1)</sup>

DEVICE NAME	PACKAGE	BODY SIZE
bq500414Q	VQFN (48)	7 mm x 7 mm

(1) For all available packages, see the orderable addendum at the end of the data sheet.

### 4 Simplified Diagram

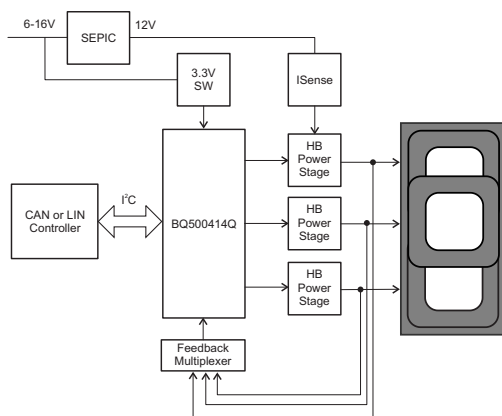

#### Efficiency Versus System Output Power With A6 Tx Coil

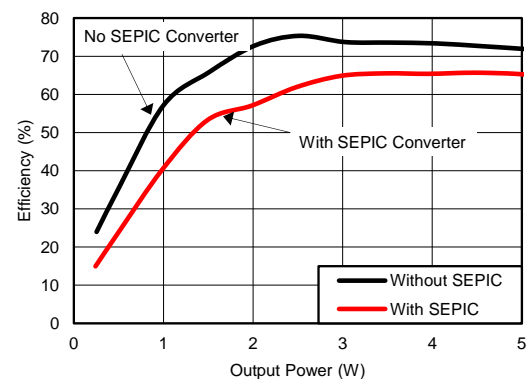

## Table of Contents

<b>1 Features</b> ..... 1 <b>2 Applications</b> ..... 1 <b>3 Description</b> ..... 1 <b>4 Simplified Diagram</b> ..... 1 <b>5 Revision History</b> ..... 2 <b>6 Pin Configuration and Functions</b> ..... 3 <b>7 Specifications</b> ..... 5 7.1 Absolute Maximum Ratings ..... 5 7.2 Handling Ratings..... 5 7.3 Recommended Operating Conditions..... 6 7.4 Thermal Information ..... 6 7.5 Electrical Characteristics..... 7 7.6 Typical Characteristics ..... 8 <b>8 Detailed Description</b> ..... 9 8.1 Overview ..... 9 8.2 Functional Block Diagram ..... 9	8.3 Feature Description..... 10 8.4 Device Functional Modes..... 17 <b>9 Applications and Implementation</b> ..... 19 9.1 Application Information..... 19 9.2 Typical Application ..... 19 <b>10 Power Supply Recommendations</b> ..... 23 <b>11 Layout</b> ..... 23 11.1 Layout Guidelines ..... 23 11.2 Layout Example ..... 24 <b>12 Device and Documentation Support</b> ..... 27 12.1 Device Support..... 27 12.2 Trademarks ..... 27 12.3 Electrostatic Discharge Caution..... 27 12.4 Glossary ..... 27 <b>13 Mechanical, Packaging, and Orderable Information</b> ..... 27
---	--

## 5 Revision History

### Changes from Original (January 2014) to Revision A

**Page**

• Updated preview document to full version. ....	1
--	---

### Changes from Revision A (March 2014) to Revision B

**Page**

• Deleted all references to the Wireless Power Consortium (WPC) A19 and A21 Transmitter Type Specifications. ....	1
• Changed Enhanced Parasitic Metal Object Detection (PMOD) bullet. ....	1
• Changed bq500414Q description. ....	1
• Changed Pin Functions Table EMI_SHIELD pin from O to I. ....	4
• Changed Pin Functions Table COIL_SEL pin from I/O to I.....	4
• Changed JEDEC document JEP157 Handling Ratings note. ....	5
• Changed Foreign Object Detection (FOD) and Parasitic Metal Object Detect (PMOD) Calibration description. ....	13
• Changed Over-Current Protection description. ....	16
• Changed Over-Voltage Protection section. ....	16

## 6 Pin Configuration and Functions

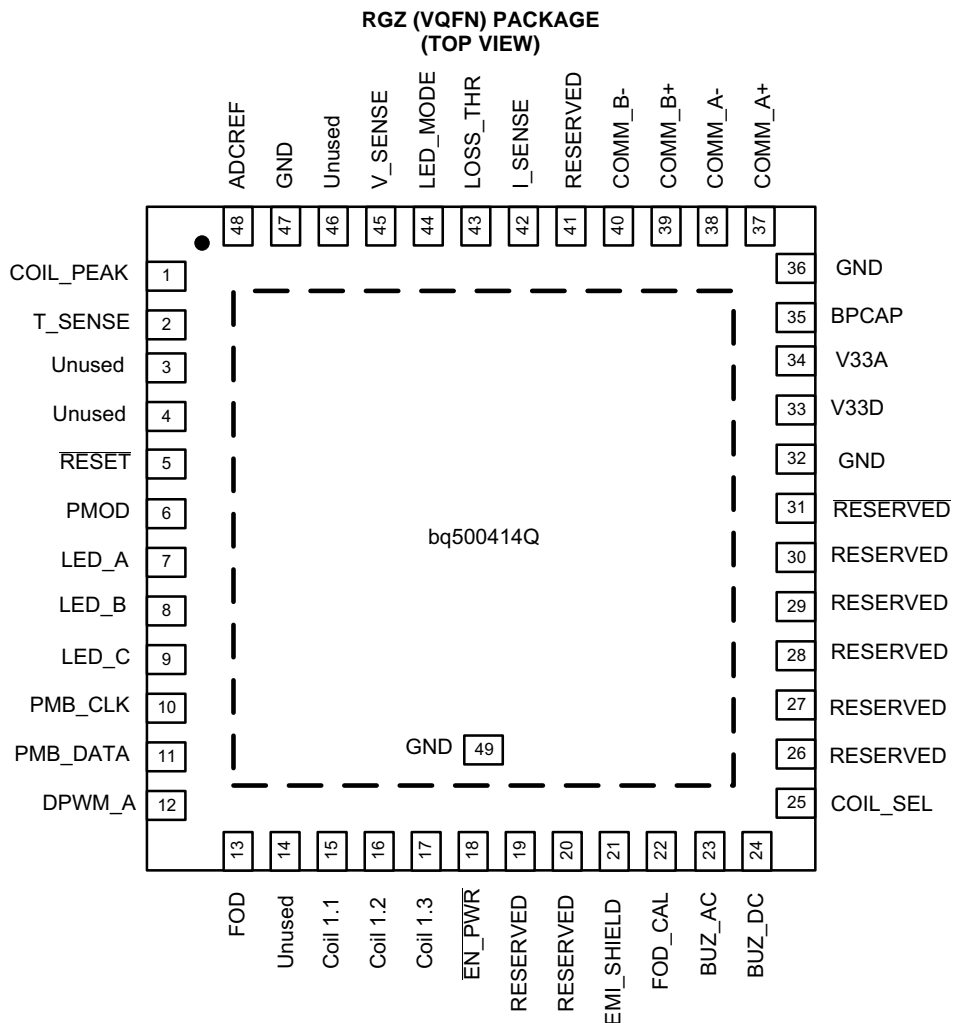

### Pin Functions

PIN		I/O	DESCRIPTION
NAME	NUMBER		
COIL_PEAK	1	I	Input from peak detect circuit
T_SENSE	2	I	Sensor input. Device shuts down when below 1 V. If not used, keep above 1 V by simply connecting to 3.3-V supply
Unused	3	I	This pin can be either connected to GND or left open. Connecting to GND can improve layout grounding
Unused	4	I	This pin can be either connected to GND or left open. Connecting to GND can improve layout grounding
$\overline{\text{RESET}}$	5	I	Device reset. Use 10-k $\Omega$ to 100-k $\Omega$ pull-up resistor to 3.3-V supply
PMOD	6	O	Select for PMOD threshold
LED_A	7	O	Connect to a LED via 470- $\Omega$ resistor for status indication. Typically GREEN
LED_B	8	O	Connect to a LED via 470- $\Omega$ resistor for status indication. Typically RED
LED_C	9	O	Connect to a LED via 470- $\Omega$ resistor for status indication. Typically YELLOW
PMB_CLK	10	I/O	10-k $\Omega$ pull-up resistor to 3.3-V supply. I <sup>2</sup> C Clock
PMB_DATA	11	I/O	10-k $\Omega$ pull-up resistor to 3.3-V supply. I <sup>2</sup> C Data
DPWM_A	12	O	PWM Output to half bridge driver. Switching dead times must be externally generated
FOD	13	O	Select for FOD threshold
Unused	14	O	Reserved, leave this pin open
COIL 1.1	15	O	Enables the first coil drive train and COMM signal selector
COIL 1.2	16	O	Enables the second coil drive train and COMM signal selector
COIL 1.3	17	O	Enables the third coil drive train and COMM signal selector
$\overline{\text{EN\_PWR}}$	18	I/O	Enable signal to the front end converter. Select the active or passive wake-up state
RESERVED	19	O	Reserved, leave this pin open
RESERVED	20	I	Reserved, connect to GND
EMI_SHIELD	21	I	Connect to 3.3-V supply to indicate EMI shield is in use. If not, connect this pin to GND
FOD_CAL	22	O	FOD Calibration
BUZ_AC	23	O	AC buzzer output. A 400-ms, 4-kHz AC pulse train when charging begins
BUZ_DC	24	O	DC buzzer output. A 400-ms DC pulse when charging begins. This could also be connected to an LED via 470- $\Omega$ resistor
COIL_SEL	25	I	Coil type select. Connect to GND for A6 type Tx
RESERVED	26	I/O	Reserved, connect to GND
RESERVED	27	I/O	Reserved, leave this pin open
RESERVED	28	I/O	Reserved, leave this pin open
RESERVED	29	I/O	Reserved, leave this pin open
RESERVED	30	I/O	Reserved, leave this pin open
$\overline{\text{RESERVED}}$	31	I/O	Reserved, connect 10-k $\Omega$ pull-down resistor to GND. Do not leave open
GND	32	—	GND
V33D	33	—	Digital Core 3.3-V supply. Be sure to decouple with bypass capacitors as close to the part as possible
V33A	34	—	Analog 3.3-V supply. This pin can be derived from V33D supply, decouple with 22- $\Omega$ resistor and additional bypass capacitors
BPCAP	35	—	Bypass capacitor for internal 1.8-V core regulator. Connect bypass capacitors to GND and to 3.3-V
GND	36	—	GND
COMM_A+	37	I	Digital demodulation noninverting input A, connect parallel to input B+
COMM_A-	38	I	Digital demodulation inverting input A, connect parallel to input B-
COMM_B+	39	I	Digital demodulation noninverting input B, connect parallel to input A+
COMM_B-	40	I	Digital demodulation inverting input B, connect parallel to input A-
RESERVED	41	I	Reserved, leave this pin open

### Pin Functions (continued)

PIN		I/O	DESCRIPTION
NAME	NUMBER		
I_SENSE	42	I	Transmitter input current, used for parasitic loss calculations. Use 40-mΩ sense resistor and A = 50 gain current sense amp
LOSS_THR	43	I	Input to program FOD/PMOD thresholds and FOD_CAL correction
LED_MODE	44	I	LED Mode Select
V_SENSE	45	I	Transmitter power train input voltage, used for FOD and Loss calculations.
Unused	46	I	This pin can be either connected to GND or left open. Connecting to GND can improve layout grounding
GND	47	—	GND
ADCREP	48	I	External reference voltage input. Connect this input to GND.
EPAD	49	—	Flood with copper GND plane and stitch vias to PCB internal GND plane

## 7 Specifications

### 7.1 Absolute Maximum Ratings<sup>(1)</sup>

over operating free-air temperature range (unless otherwise noted)

	MIN	MAX	UNIT
Voltage applied at V33D to DGND	−0.3	3.6	V
Voltage applied at V33A to AGND	−0.3	3.6	
Voltage applied to any pin <sup>(2)</sup>	−0.3	3.6	

- (1) Stresses beyond those listed under *absolute maximum ratings* may cause permanent damage to the device. These are stress ratings only and functional operation of the device at these or any other conditions beyond those indicated under *recommended operating conditions* is not implied. Exposure to absolute-maximum-rated conditions for extended periods may affect device reliability.
- (2) All voltages referenced to GND.

### 7.2 Handling Ratings

	MIN	MAX	UNIT	
T <sub>stg</sub> Storage temperature range	−40	150	°C	
V <sub>(ESD)</sub> <sup>(1)</sup>	Human-Body Model (HBM) <sup>(2)</sup>	2	2	kV
	Charged-Device Model (CDM) <sup>(3)</sup>	750	750	kV

- (1) Electrostatic discharge (ESD) to measure device sensitivity and immunity to damage caused by assembly line electrostatic discharges in to the device.
- (2) Level listed above is the passing level per ANSI, ESDA, and JEDEC JS-001. JEDEC document JEP155 states that 500-V HBM allows safe manufacturing with a standard ESD control process.
- (3) Level listed above is the passing level per EIA-JEDEC JESD22-C101. JEDEC document JEP157 states that 250-V CDM allows manufacturing without risk of damaging the device with a standard ESD control process.

### 7.3 Recommended Operating Conditions

over operating free-air temperature range (unless otherwise noted)

		MIN	NOM	MAX	UNIT
V	Supply voltage during operation, V33D, V33A	3.0	3.3	3.6	V
T <sub>A</sub>	Operating free-air temperature range	-40		85	°C
T <sub>J</sub>	Junction temperature			85	

### 7.4 Thermal Information

THERMAL METRIC <sup>(1)</sup>		bq500414Q	UNIT
		RGZ 48 PINS	
R <sub>θJA</sub>	Junction-to-ambient thermal resistance	27.1	°C/W
R <sub>θJC(top)</sub>	Junction-to-case (top) thermal resistance	12.9	
R <sub>θJB</sub>	Junction-to-board thermal resistance	4.3	
ψ <sub>JT</sub>	Junction-to-top characterization parameter	0.2	
ψ <sub>JB</sub>	Junction-to-board characterization parameter	4.3	
R <sub>θJC(bot)</sub>	Junction-to-case (bottom) thermal resistance	0.6	

 (1) For more information about traditional and new thermal metrics, see the *IC Package Thermal Metrics* application report, [SPRA953](#).

## 7.5 Electrical Characteristics

over operating free-air temperature range (unless otherwise noted)

PARAMETER		TEST CONDITIONS	MIN	NOM	MAX	UNIT
<b>SUPPLY CURRENT</b>						
$I_{V33A}$	Supply current	V33A = 3.3 V		8	15	mA
$I_{V33D}$		V33D = 3.3 V		44	55	
$I_{Total}$		V33D = V33A = 3.3 V		52	60	
<b>INTERNAL REGULATOR CONTROLLER INPUTS/OUTPUTS</b>						
V33	3.3-V linear regulator	Emitter of NPN transistor	3.25	3.3	3.6	V
V33FB	3.3-V linear regulator feedback			4	4.6	
$I_{V33FB}$	Series pass base drive	$V_{IN} = 12$ V; current into V33FB pin		10		mA
Beta	Series NPN pass device		40			
<b>EXTERNALLY SUPPLIED 3.3 V POWER</b>						
V33D	Digital 3.3-V power	$T_A = 25^\circ\text{C}$	3		3.6	V
V33A	Analog 3.3-V power	$T_A = 25^\circ\text{C}$	3		3.6	
V33Slew	3.3-V slew rate	3.3-V slew rate between 2.3 V and 2.9 V, V33A = V33D	0.25			V/ms
<b>DIGITAL DEMODULATION INPUTS: COMM_A+, COMM_A-, COMM_B+, COMM_B-</b>						
$V_{CM}$	Common mode voltage each pin		-0.15		1.631	V
COMM+, COMM-	Modulation voltage digital resolution			1		mV
$R_{EA}$	Input Impedance	Ground reference	0.5	1.5	3	M $\Omega$
$I_{OFFSET}$	Input offset current	1-k $\Omega$ source impedance	-5		5	$\mu\text{A}$
<b>ANALOG INPUTS: V_IN, V_SENSE, I_SENSE, T_SENSE, LED_MODE, LOSS_THR</b>						
$V_{ADC\_OPEN}$	Voltage indicating open pin	LED_MODE, LOSS_THR open	2.37			V
$V_{ADC\_SHORT}$	Voltage indicating pin shorted to GND	LED_MODE, LOSS_THR shorted to ground			0.36	
$V_{ADC\_RANGE}$	Measurement range for voltage monitoring	ALL ANALOG INPUTS	0		2.5	
INL	ADC integral nonlinearity		-2.5		2.5	mV
$I_{lkq}$	Input leakage current	3 V applied to pin			100	nA
$R_{IN}$	Input impedance	Ground reference	8			M $\Omega$
$C_{IN}$	Input capacitance				10	pF
<b>DIGITAL INPUTS/OUTPUTS</b>						
$V_{OL}$	Low-level output voltage	$I_{OL} = 6$ mA , V33D = 3 V			DGND1 + 0.25	V
$V_{OH}$	High-level output voltage	$I_{OH} = -6$ mA , V33D = 3 V		V33D - 0.6 V		
$V_{IH}$	High-level input voltage	V33D = 3 V	2.1		3.6	
$V_{IL}$	Low-level input voltage	V33D = 3.5 V			1.4	
$I_{OH(MAX)}$	Output high source current				4	mA
$I_{OL(MAX)}$	Output low sink current				4	
<b>SYSTEM PERFORMANCE</b>						
$V_{RESET}$	Voltage where device comes out of reset	V33D pin			2.4	V
$t_{RESET}$	Pulse width needed for reset	RESET pin	2			$\mu\text{s}$
$f_{SW}$	Switching Frequency		120		205	kHz
$t_{detect}$	Time to detect presence of device requesting power				0.5	s

## 7.6 Typical Characteristics

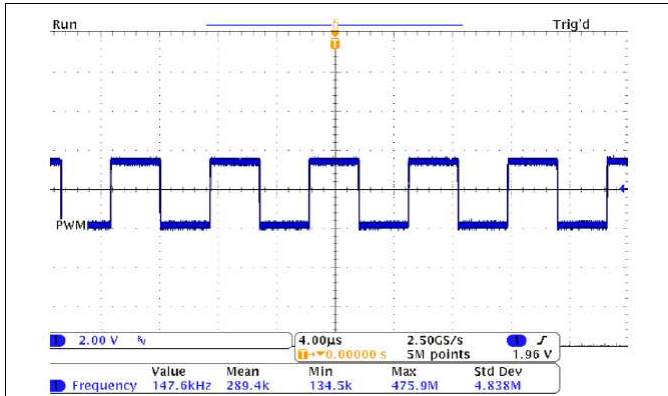

Figure 1. Typical PWM Signal

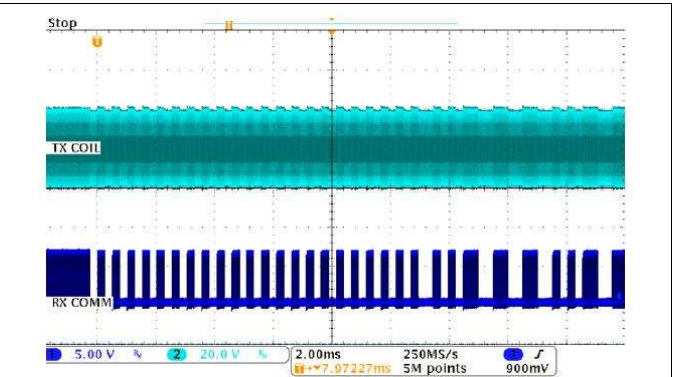

Figure 2. Typical Tx Coil and Rx Communication Signals

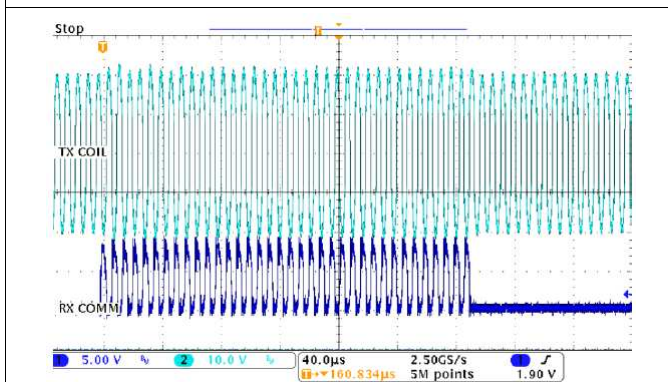

Figure 3. Tx Coil and Rx Communication Signals with Rx No Load

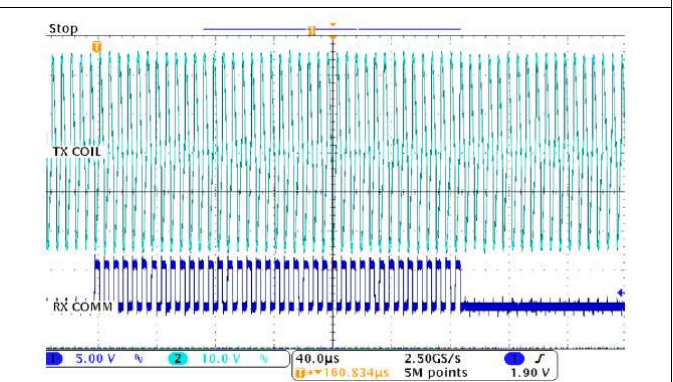

Figure 4. Tx Coil and Rx Communication Signals with Rx 5W Load

## 8 Detailed Description

### 8.1 Overview

The principle of wireless power transfer is simply an open cored transformer consisting of transmitter (Tx) and receiver (Rx) coils. The transmitter coil and electronics are typically built into a charger pad and the receiver coil and electronics are typically built into a portable device, such as a cell-phone.

When the receiver coil is positioned on the transmitter coil, magnetic coupling occurs once the transmitter coil is driven. The flux is coupled into the secondary coil which induces a voltage and current flows. The secondary voltage is rectified, and power can be transferred effectively to a load, wirelessly. Power transfer can be managed through any of various familiar closed-loop control schemes.

The bq500414Q sends an analog ping to detect the presence of a receiver on the pad. An external enable trigger or proximity detector can also be used to provide the means of detecting the presence of a receiver. The detector can output an enable signal to the regulator supplying the bq500414Q and the device powers up, or the enable signal can start the Tx via I<sup>2</sup>C command. Once the bq500414Q is active, it pings the three coils sequentially to detect and power up the Rx. Once the Rx is powered up, it sends the communication packages to the Tx. The package information can be fetched by the Tx through demodulating the COMM feedback signal, which is a scaled version of primary coil voltage. The COMM feedback signal is multiplexed through analog switches and is synchronized to the coil being driven. To select the best coil match, the bq500414Q looks for the strongest COMM signal. Note that only one coil is driven at a time. The driven coil is tolerant of slight misalignment of the Rx while power is being transferred. Actually displacing the Rx to an adjacent coil while charging is allowable, the sequential ping sequence and detection to determine the best matching coil to drive continues to repeat. bq500414Q provides I<sup>2</sup>C interface to support some read and write commands, which can also be used to start the Tx and temporarily shift the Tx operating frequency.

### 8.2 Functional Block Diagram

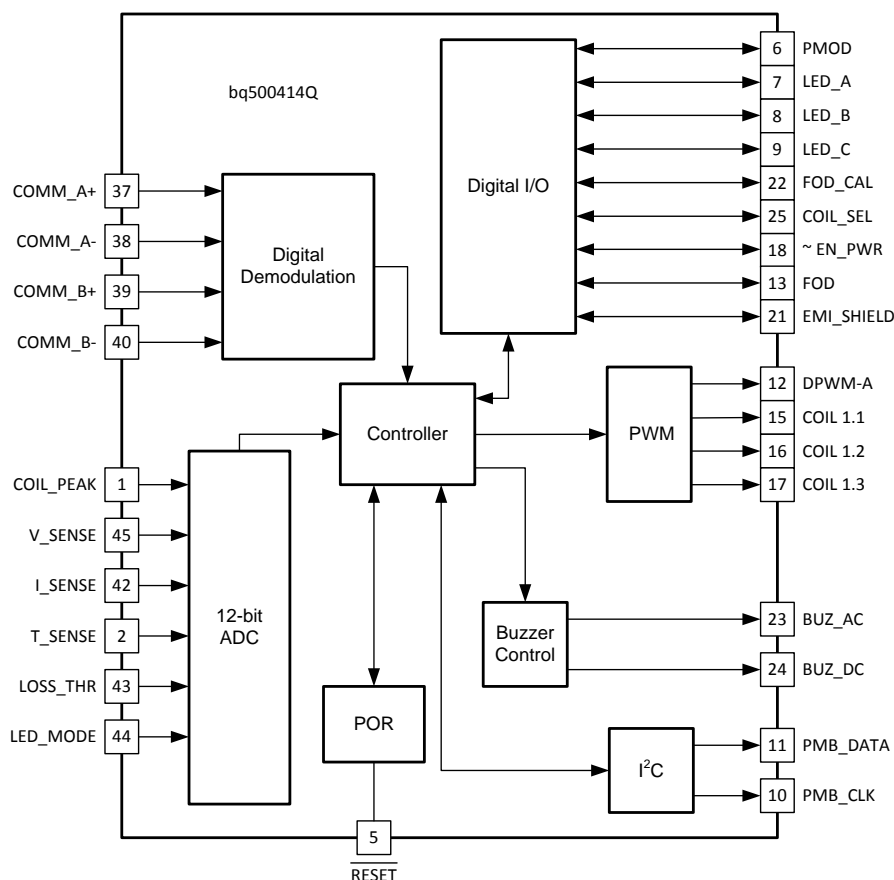

## 8.3 Feature Description

### 8.3.1 A6 Coil Specification

bq500414Q supports WPC A6 transmitter type. The coil and matching capacitor specification for the A6 transmitter has been established by WPC standard. This is fixed and cannot be changed on the transmitter side.

The bq500414Q is primarily intended to drive a 3 coil array but it can also be used to drive a single coil or two coils. For single coil operation, the other coils and associated electronics are simply omitted.

Schematics and BOM can be found on the product folder at [www.ti.com](http://www.ti.com).

For a current list of coil vendors please see:

- *bqTESLA Transmitter Coil Vendors*, [SLUA649](#)

### 8.3.2 EMI Shield

TI recommends using a PCB based Electromagnetic Interference (EMI) shield to improve the EMI performance. The shield needs to be grounded. Pin 21 is used to indicate if EMI shield is in use. See product folder at [www.ti.com](http://www.ti.com) for additional information on reference designs and applications.

### 8.3.3 I<sup>2</sup>C Interface

The bq500414Q supports read and write commands via I<sup>2</sup>C, as well as firmware upgrade. This could help the host controller monitor system information, control output power, and temporarily shift the Tx operating frequency.

The slave address assigned to the bq500414Q has been hardcoded to 20 (decimal). The hardware can support 100-kHz, 400-kHz, or 1-MHz I<sup>2</sup>C operation. Contact Texas Instruments for additional information on I<sup>2</sup>C interface.

### 8.3.4 Active or Passive Wake-up State

At power up, the bq500414Q will read EN\_PWR pin voltage. If it is low, the bq500414Q device will be in active wake-up state. It will send an analog ping to detect if a compatible Rx is present and then sends a digital ping to power up the Rx. If the EN\_PWR pin voltage is high, the bq500414Q will be in a passive wake-up state and considers that the SHUTDOWN command is issued. It will not send any analog ping or digital ping to detect the presence Rx, until the SHUTDOWN command is disabled through I<sup>2</sup>C. Once the SHUTDOWN command is disabled, the bq500414Q device will be in active wake-up state and send the analog ping to detect the Rx. At the same time, it drives EN\_PWR pin LOW to enable the SEPIC converter. This feature enables the use of a customer defined proximity sensor.

### 8.3.5 Smart Key or Immobilizer Handling

The host controller may temporarily shift the bq500414Q operating frequency via I<sup>2</sup>C, when a smart key or an immobilizer is being used to avoid the interference.

## Feature Description (continued)

### 8.3.6 Option Select Pins

There are four option select pins (pin 18  $\sim$ EN\_PWR, pin 21 EMI\_SHIELD, pin 43 LOSS\_THR and pin 44 LED\_MODE) on the bq500414Q. All the pin voltages will be read by bq500414Q at power up.

- Pin 18 is used to indicate if the Tx should be go into active or passive wake-up state. This pin is a logic input that can be tied to 3.3-V or GND for indication. This pin is also the active LOW enable signal to the SEPIC.
- Pin 21 is used to indicate if EMI shield is in use. This pin is a logic input that can be tied to 3.3-V or GND for indication.
- Pin 43 is used to program the Loss Threshold and FOD Calibration.
- Pin 44 is used to select the LED mode of the device. At power up, a bias current is applied to pins LED\_MODE and LOSS\_THR and the resulting voltage is measured in order to identify the value of the attached programming resistor. For LED\_MODE, the selected bin determines the LED behavior based on [Table 1](#). For the LOSS\_THR, the selected bin sets a threshold based on [Table 2](#). See [Foreign Object Detection \(FOD\) and Parasitic Metal Object Detect \(PMOD\) Calibration](#) section for more information.

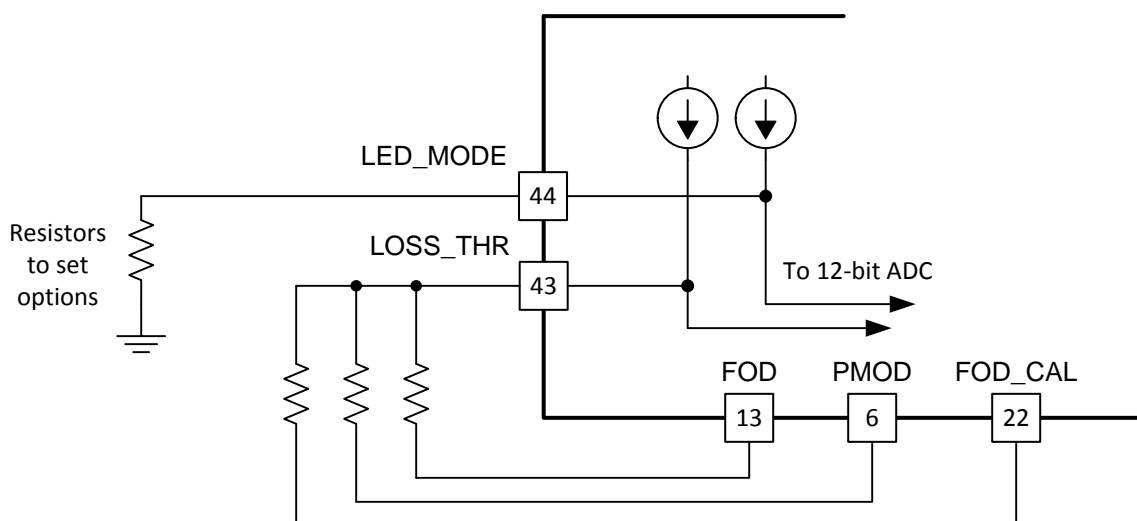

Figure 5. Pin 43 LOSS\_THR and Pin 44 LED\_MODE Connections

**Feature Description (continued)**
**8.3.7 LED Modes**

The bq500414Q can directly drive three LED outputs (pin 7, pin 8, and pin 9) through a simple current limit resistor (typically 470-Ω), based on the mode selected. The three current limit resistors can be individually adjusted to tune or match the brightness of the LEDs. Do not exceed the maximum output current rating of the device.

The selection resistor, connected between pin 44 and GND, selects one of the desired LED indication schemes presented in [Table 1](#).

**Table 1. LED Modes**

LED CONTROL OPTION	LED SELECTION RESISTOR	DESCRIPTION	LED	OPERATIONAL STATES				
				STANDBY	POWER TRANSFER	CHARGE COMPLETE	FAULT	FOD Warning
X	< 36.5 kΩ	Reserved, do not use	LED1, green	-	-	-	-	-
			LED2, red					
			LED3, amber					
1	42.2 kΩ	Choice number 1	LED1, green	Off	Blink slow <sup>(1)</sup>	On	Off	Off
			LED2, red	Off	Off	Off	On	Blink fast <sup>(2)</sup>
			LED3, amber	-	-	-	-	-
2	48.7 kΩ	Choice number 2	LED1, green	On	Blink slow <sup>(1)</sup>	On	Off	Off
			LED2, red	On	Off	Off	On	Blink fast <sup>(2)</sup>
			LED3, amber	-	-	-	-	-
3 <sup>(3)</sup>	56.2 kΩ	Choice number 3	LED1, green	Off	On	Off	Blink fast <sup>(2)</sup>	On
			LED2, red	-	-	-	-	-
			LED3, amber	-	-	-	-	-
4	64.9 kΩ	Choice number 4	LED1, green	Off	On	Off	Off	Off
			LED2, red	Off	Off	Off	On	Blink fast <sup>(2)</sup>
			LED3, amber	-	-	-	-	-
5	75 kΩ	Choice number 5	LED1, green	Off	Off	On	Off	Off
			LED2, red	Off	On	Off	Off	On
			LED3, amber	Off	Off	Off	Blink slow <sup>(1)</sup>	Off
6	86.6 kΩ	Choice number 6	LED1, green	Off	Blink slow <sup>(1)</sup>	On	Off	Off
			LED2, red	Off	Off	Off	On	Blink fast <sup>(2)</sup>
			LED3, amber	Off	Off	Off	Off	Off
7	100 kΩ	Choice number 7	LED1, green	Off	Blink slow <sup>(1)</sup>	Off	Off	Off
			LED2, red	Off	Off	On	Off	Off
			LED3, amber	Off	Off	Off	On	Blink fast <sup>(2)</sup>

(1) Blink slow = 0.625 Hz

(2) Blink fast = 2.5 Hz

(3) The indication of the shutdown after an Negative Temperature Coefficient (NTC) event may experience a delay in the rapid LED blinking even though the power transfer has been disabled. The indication delay may persist up to as long as the entire NTC FAULT holdoff time.

### 8.3.8 Foreign Object Detection (FOD) and Parasitic Metal Object Detect (PMOD) Calibration

The bq500414Q supports improved FOD (WPC v1.1) and enhanced PMOD (WPC v1.0) features. Continuously monitoring input power, known losses, and the value of power reported by the Rx device being charged, the bq500414Q can estimate how much power is unaccounted for and presumed lost due to metal objects placed in the wireless power transfer path. If this unexpected loss exceeds the threshold set by the FOD or PMOD resistors, a fault is indicated and power transfer is halted. Whether the FOD or the PMOD algorithm is used is determined by the ID packet of the receiver being charged. The ultimate goal of the FOD feature is to protect misplaced metal objects from becoming hot. Reducing the loss threshold and making the system too sensitive will lead to false trips and a bad user experience. Find the balance which best suits the application. If the application requires disabling one function or the other (or both), it is possible by leaving the respective FOD/PMOD pin open. For example, to selectively disable the PMOD function, PMOD (pin 6) should be left open.

#### NOTE

Disabling FOD results in a Tx solution that is not WPC 1.1 Compliant

Resistors of 1% tolerance should be used for a reliable selection of the desired threshold. The FOD and PMOD resistors (pin 13 and pin 6) program the permitted power loss for the FOD and PMOD algorithms respectively. The FOD\_CAL resistor (pin 22), can be used to compensate for any load dependent effect on the power loss. Using a calibrated FOD reference receiver with no foreign objects present, the FOD\_CAL resistor should be selected such that the calculated loss across the load range is substantially constant (within ~100-mW). After correcting for the load dependence, the FOD and PMOD thresholds should be re-set above the resulting average by approximately 400-mW in order for the transmitter to satisfy the WPC requirements on tolerated heating.

Contact Texas Instruments for the Tx Tuning Tool to set appropriate FOD, PMOD, and FOD\_CAL resistor values for your design.

**Table 2. Option Select Bins**

BIN NUMBER	RESISTANCE (kΩ)	LOSS THRESHOLD (mW)
0	< 36.5	250
1	42.2	300
2	48.7	350
3	56.2	400
4	64.9	450
5	75.0	500
6	86.6	550
7	100	600
8	115	650
9	133	700
10	154	750
11	178	800
12	205	850
13	> 237	Feature Disabled

### 8.3.9 Shut Down via External Thermal Sensor or Trigger

Typical applications of the bq500414Q do not require additional thermal protection. This shutdown feature is provided for enhanced applications and is not limited to thermal shutdown. The key parameter is the 1.0-V threshold on pin 2 T\_SENSE. Voltage below 1.0-V on pin 2 causes the device to shut down.

The application of thermal monitoring via a Negative Temperature Coefficient (NTC) sensor, for example, is straightforward. The NTC forms the lower leg of a temperature dependant voltage divider. The NTC leads are connected to the bq500414Q device, pin 2 and GND. The threshold on pin 2 is set to 1.0 V, below which the system shuts down and a fault is indicated (depending on LED mode chosen).

To implement this feature follow these steps:

1. Consult the NTC datasheet and find the resistance vs temperature curve.
2. Determine the actual temperature where the NTC will be placed by using a thermal probe.
3. Read the NTC resistance at that temperature in the NTC datasheet, that is R\_NTC.
4. Use the following formula to determine the upper leg resistor (R\_Setpoint):

$$R\_Setpoint = 2.3 \times R\_NTC \quad (1)$$

The system restores normal operation after approximately five minutes or if the receiver is removed. If the feature is not used, this pin must be pulled high.

---

#### NOTE

Pin 2 T\_SENSE must always be terminated, otherwise erratic behavior may occur.

---

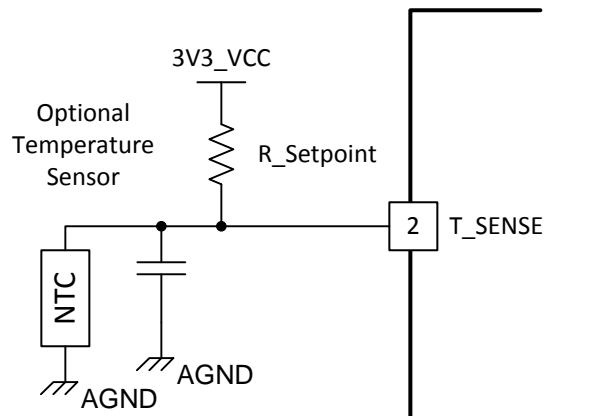

**Figure 6. Negative Temperature Coefficient (NTC) Application**

### 8.3.10 Fault Handling and Indication

The following is a table of End Power Transfer (EPT) packet responses, fault conditions, and the duration how long the condition lasts until a retry is attempted. The LED mode selected determines how the LED indicates the condition or fault.

**Table 3. Fault Handling and Indication**

CONDITION	DURATION <sup>(1)</sup> (BEFORE RETRY)	HANDLING
EPT-00	Immediate <sup>(2)</sup>	Unknown
EPT-01	5 seconds	Charge complete
EPT-02	Infinite	Internal fault
EPT-03	5 minutes	Over temperature
EPT-04	Immediate <sup>(2)</sup>	Over voltage
EPT-05	Immediate <sup>(2)</sup>	Over current
EPT-06	Infinite	Battery failure
EPT-07	Not applicable	Reconfiguration
EPT-08	Immediate <sup>(2)</sup>	No response
OVP (over voltage)	Immediate <sup>(2)</sup>	
OC (over current)	1 minute	
NTC (external sensor)	5 minutes	
PMOD/FOD warning	12 seconds	10 seconds LED only, 2 seconds LED + buzzer
PMOD/FOD	5 minutes	

- (1) After a FAULT, the magnetic field is re-characterized in order to improve the ability to detect the removal of the at-fault receiver. If the receiver is removed in the first second immediately following the detection of this fault (before the re-characterization is complete), the field corresponding to an empty pad may be associated with the faulty receiver and the LED indication may continue to indicate a fault state even though no receiver is present. This indication will persist until either the HOLDOFF time expires or a new receiver disturbs the field, at which time normal operation, with proper LED indication, will be resumed.
- (2) Immediate is less than 1 second.

### 8.3.11 Power Transfer Start Signal

The bq500414Q features two signal outputs to indicate that power transfer has begun. Pin 23 BUZ\_AC outputs a 400-ms duration, 4-kHz square wave for driving low cost AC type ceramic buzzers. Pin 24 BUZ\_DC outputs logic high, also for 400-ms, which is suitable for DC type buzzers with built-in tone generators, or as a trigger for any type of customized indication scheme. Do not exceed 4-mA loading from either of these pins which is more than adequate for small signaling and actuation. If not used, these pins should be left open.

### 8.3.12 Power-On Reset

The bq500414Q has an integrated Power-On Reset (POR) circuit which monitors the supply voltage and handles the correct device startup sequence. Additional supply voltage supervisor or reset circuits are not needed.

### 8.3.13 External Reset, $\overline{\text{RESET}}$ Pin

The bq500414Q can be forced into a reset state by an external circuit connected to the  $\overline{\text{RESET}}$  pin. A logic low voltage on this pin holds the device in reset. For normal operation, this pin is pulled up to 3.3-V supply with a 10-k $\Omega$  pull-up resistor.

### 8.3.14 Trickle Charge and CS100

The WPC specification provides an End-of-Power Transfer message (EPT-01) to indicate charge complete. Upon receipt of the charge complete message, the bq500414Q will change the LED indication. The exact indication depends on the LED\_MODE chosen.

In some battery charging applications there is a benefit to continue the charging process in trickle-charge mode to top off the battery. There are several information packets in the WPC specification related to the levels of battery charge (Charge Status). The bq500414Q uses these commands to enable top-off charging. The bq500414Q changes the LED indication to reflect charge complete when a Charge Status message is 100% received, but unlike the response to an EPT, it will not halt power transfer while the LED indicates charge complete. The mobile device can use a CS100 packet to enable trickle charge mode.

If the reported charge status drops below 90%, normal charging indication will be resumed.

#### 8.3.14.1 Over-Current Protection

The bq500414Q has an integrated current protection feature which monitors the input current reported by the current sense resistor and amplifier. If the input current exceeds a predetermined threshold, a fault is indicated and power transfer is halted for one minute.

If this feature is desired, the sense resistor and amplifier are required. If this feature is not desired, and WPC v1.1 compliant (FOD) is not required, the I\_SENSE input pin to the bq500414Q (pin 42) should be grounded.

---

#### NOTE

Always terminate the I\_SENSE pin (pin 42), either with the output of a current monitor circuit or by connecting to ground.

---

### 8.3.15 Over-Voltage Protection

When the Rx is quickly moved from a low coupling position to a high coupling position, the rectified voltage on the Rx could get to very high before the Tx reacts to the change. Per WPC protocol, there is certain time duration between the Control Error Packages, so the Tx will not be able to react instantaneously. The bq500414Q uses a peak-detect circuit to prevent the Rx from being over-voltage.

## 8.4 Device Functional Modes

### 8.4.1 Power Transfer

Power transfer depends on coil coupling. Coupling is dependant on the distance between coils, alignment, coil dimensions, coil materials, number of turns, magnetic shielding, impedance matching, frequency, and duty cycle.

Most importantly, the receiver and transmitter coils must be aligned for best coupling and efficient power transfer. The smaller the space between the coils is, the better the coupling; however, the practical distance is set to be less than 5-mm, as defined within the WPC specification, to account for housing and interface surfaces.

Shielding is added as a backing to both the transmitter and receiver coils to direct the magnetic field to the coupled zone. Magnetic fields outside the coupled zone do not transfer power. Thus, shielding also serves to contain the fields to avoid coupling to other adjacent system components.

Regulation can be achieved by controlling any one of the coil coupling parameters. However, for WPC compatibility, the transmitter-side coils and capacitance are specified and the resonant frequency point is fixed. Power transfer is thus regulated by changing the frequency along the resonance curve from 120-kHz to 205-kHz, (that is the higher the frequency is, the lower the power). Duty cycle remains constant at 50% throughout the power band and is reduced only once 205-kHz is reached.

The WPC standard describes the dimensions, materials of the coils, and information regarding the tuning of the coils to resonance. The value of the inductor and resonant capacitor are critical to proper operation and system efficiency.

### 8.4.2 Communication

Communication within the WPC is from the receiver to the transmitter, where the receiver tells the transmitter to send power and how much. In order to regulate, the receiver must communicate with the transmitter whether to increase or decrease frequency. The receiver monitors the rectifier output and using Amplitude Modulation (AM), sends packets of information to the transmitter. A packet is comprised of a preamble, a header, the actual message and a checksum, as defined by the WPC standard.

The receiver sends a packet by modulating an impedance network. This AM signal reflects back as a change in the voltage amplitude on the transmitter coil. The signal is demodulated and decoded by the transmitter-side electronics and the frequency of its coil-drive output is adjusted to close the regulation loop. The bq500414Q features internal digital demodulation circuitry.

The modulated impedance network on the receiver can either be resistive or capacitive. [Figure 7](#) shows the resistive modulation approach, where a resistor is periodically added to the load, and the resulting amplitude change in the transmitter voltage. [Figure 8](#) shows the capacitive modulation approach, where a capacitor is periodically added to the load and the resulting amplitude change in the transmitter voltage.

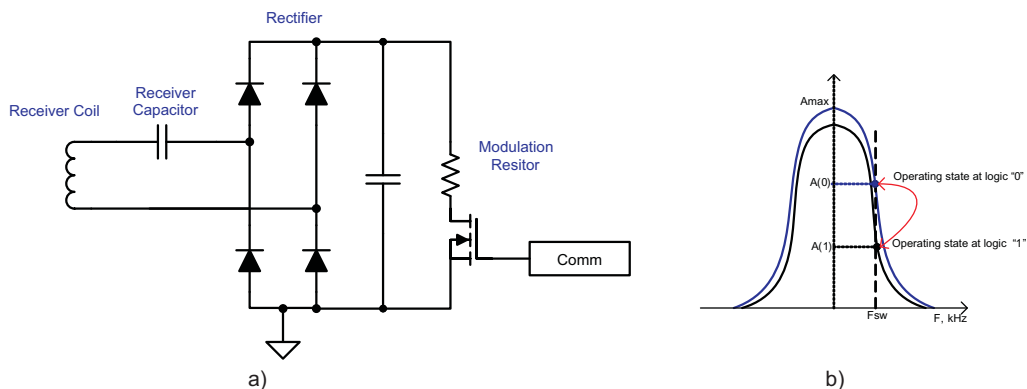
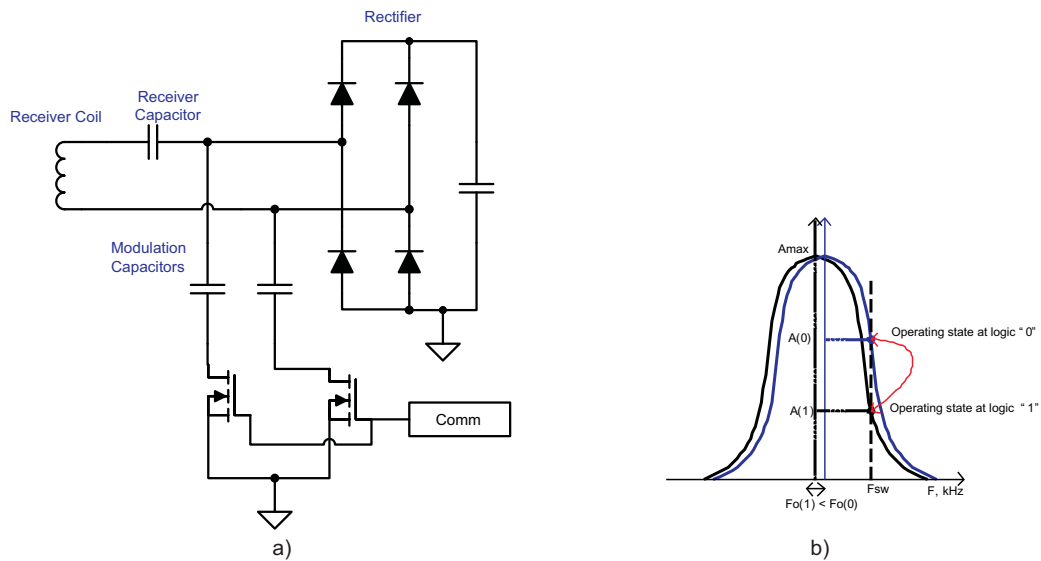

Figure 7. Receiver Resistive Modulation Circuit

## Device Functional Modes (continued)



**Figure 8. Receiver Capacitive Modulation Circuit**

### 8.4.3 Power Trains

The bq500414Q drives three independent half bridges. Each half bridge drives one coil from the coil set assembly. The TPS28225 is the recommended driver device for this application. It features high-side drive capability which enables the use of N-channel MOSFETs throughout. Gate-drive supply can be derived from a primitive active voltage divider. A highly regulated supply is not required to drive MOSFET gates.

### 8.4.4 Signal Processing Components

The COMM signal used to control power transfer is derived from the coil voltage. Each coil has its own signal processing chain. The AC coupled coil voltage is scaled down to a manageable level and biased to a 1-V offset. Series connected diodes are provided for protection from any possible transients. The three signal processing chains are then multiplexed together via analog switches. Thus, the correct signal processing chain and COMM signal used to control power transfer is from the coil being driven.

## 9 Applications and Implementation

### 9.1 Application Information

The bq500414Q device is a wireless power transmitter controller designed for automotive applications. It integrates all functions required to control wireless power transfer to a WPC v1.1 compliant receiver. There are several tools available for the design of the system. See the product folder on [www.ti.com](http://www.ti.com) for more details. The following sections highlight some of the system design considerations.

### 9.2 Typical Application

The application block diagram for the transmitter is shown in [Figure 9](#).

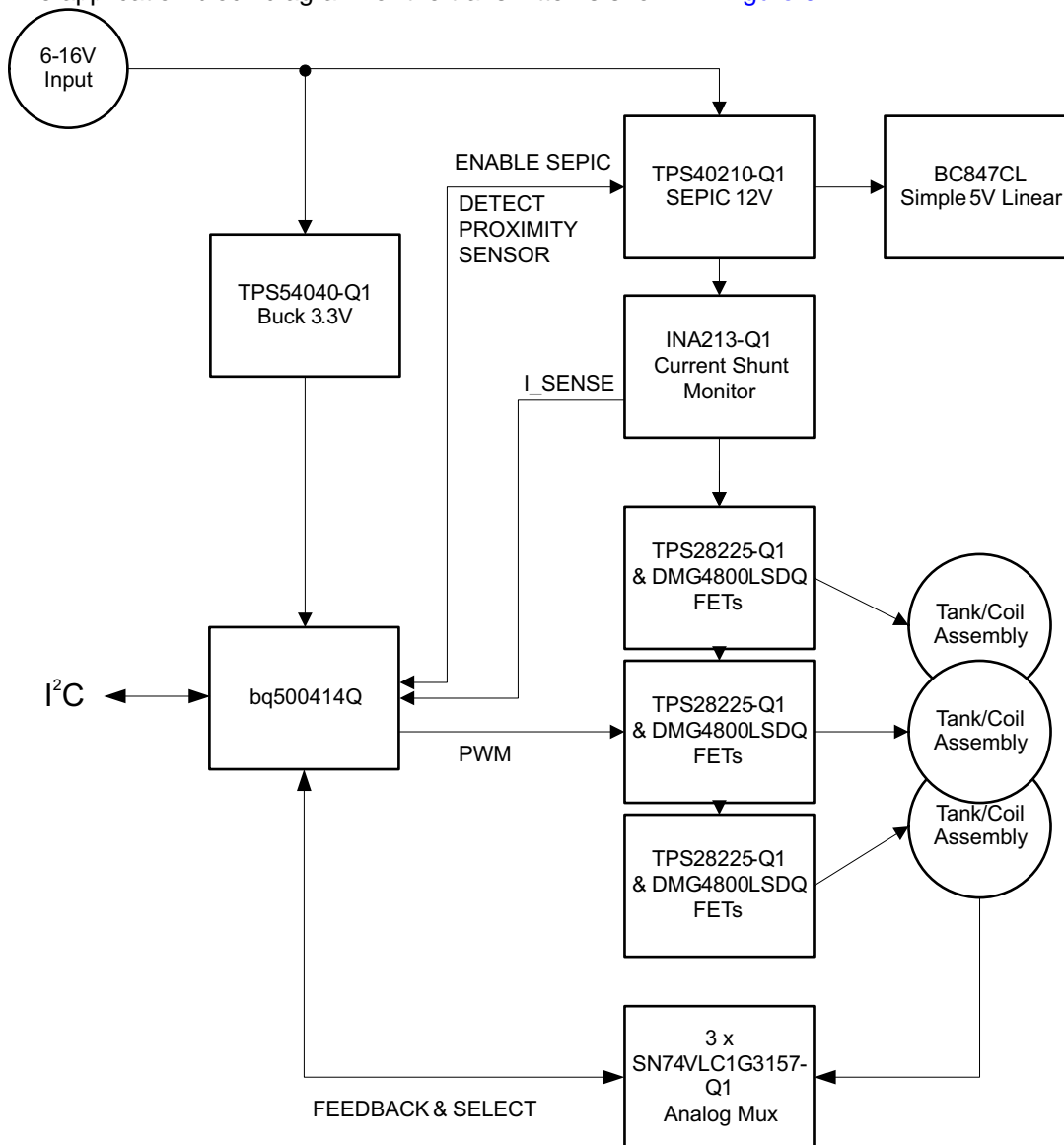

Figure 9. bq500414Q System Diagram

## Typical Application (continued)

### 9.2.1 Design Requirements

#### 9.2.1.1 Capacitor Selection

Capacitor selection is critical to proper system operation. The total capacitance value of 2 x 68-nF ( 2 x (68-nF + 5.6-nF) in the center coil) is required in the resonant tank. This is the WPC system compatibility requirement, not a guideline.

---

#### NOTE

A total capacitance value of 2 x 68-nF (additional 2 x 5.6-nF center coil) (C0G dielectric type, 100V rating) is required in the resonant tank to achieve the correct resonance frequency.

---

The capacitors chosen must be rated for at least 100 V and must be of a high quality C0G dielectric (sometimes also called NP0). These are typically available in a 5% tolerance, which is adequate. The use of X7R types or below is not recommended if WPC compliance is required because critical WPC Certification Testing, such as the minimum modulation or ensured power requirements, might fail.

The designer can combine capacitors to achieve the desired capacitance value. Various combinations can work depending on market availability. All capacitors must be of C0G types, not mixed with any other dielectric types.

#### 9.2.1.2 Current Monitoring Requirements

The bq500414Q is WPC1.1 ready. In order to enable the PMOD or FOD features, current monitoring must be provided in the design.

For proper scaling of the current monitor signal, the current sense resistor should be 40-m $\Omega$  and the current shunt amplifier should have a gain of 50, such as the INA213Q1. For FOD accuracy, the current sense resistor must be a quality component with 1% tolerance, at least 1/4-Watt rating, and a temperature stability of  $\pm 200$  PPM. Proper current sensing techniques in the application hardware should also be observed.

#### 9.2.1.3 All Unused Pins

All unused pins can be left open unless otherwise indicated. Please refer to the Pin Functions table. Grounding of unused pins, if it is an option, can improve PCB layout.

#### 9.2.1.4 Input Regulators

The bq500414Q requires 3.3-V<sub>DC</sub> to operate. A buck converter is used to step down from the automotive rail voltage, such as the TPS54040 used in this design.

The power train bridge circuitry requires 12 V, and it is fed from a SEPIC converter using the TPS40210 controller. Since the automotive rail voltage can vary widely, this acts as a type of pre-regulator.

## Typical Application (continued)

### 9.2.1.5 Input Power Requirements

The design works with 6-V to 16-V input voltage. A6 Tx type requires 12-V system voltage. A SEPIC converter TPS40210 is included in the design to work with 6-V to 16-V input voltage for automotive application.

### 9.2.2 Detailed Design Procedure

To begin the design process a few parameters must be decided upon. The design needs to know the following:

- Active or Passive Wake-up State
- EMI Shield
- LED Mode
- Number of Tx coils (1, 2, or 3)

#### 9.2.2.1 Active or Passive Wake-up State

bq500414Q detects the pin 18  $\sim$ EN\_PWR voltage at power up. If it's high, the bq500414Q will not send any analog ping to detect the Rx, until SHUTDOWN command is disabled through I<sup>2</sup>C. A proximity sensor could be used with this feature.

#### 9.2.2.2 EMI Shield

EMI shield can help improve EMI performance. Pin 21 EMI\_SHIELD is used to indicate if EMI shield is in use.

#### 9.2.2.3 LED mode

bq500414Q can directly drive three LED outputs (pin 7 LED\_A, pin 8 LED\_B, and pin 9 LED\_C). Select one of the desired LED indication schemes by choosing the selection resistor connected between pin 44 LED\_MODE and GND.

#### 9.2.2.4 Number of Transmitter Coils

bq500414Q supports 1, 2, or 3 coils. Please refer to the product folder on [www.ti.com](http://www.ti.com) for more information on the 3-coil design.

Typical Application (continued)

9.2.3 Application Performance Plots

The system efficiency with A6 Tx type coil is shown in Figure 10. The SEPIC converter that provides 12-V causes some efficiency drop.

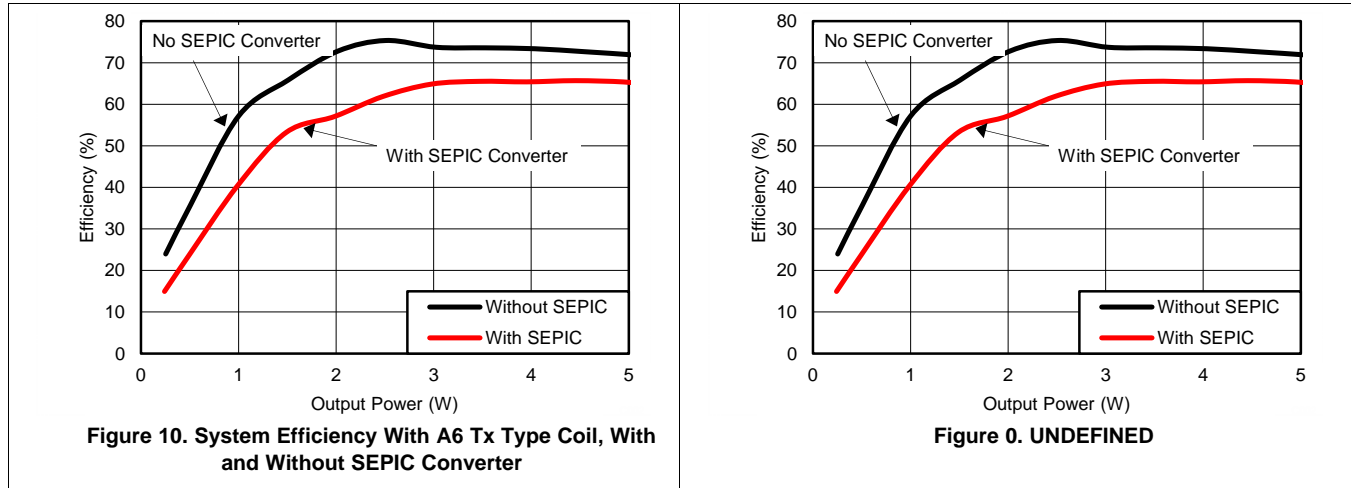

The frequency shift operation is shown in the Qi Sniffer capture in Figure 11. The Rx is placed on the Tx with no load. The operating frequency is 154-kHz. Then a `FREQ_SHIFT` command is issued through I<sup>2</sup>C, to shift the operating frequency to 190-kHz for 50,000-ms. After requested 50,000 ms, the operating frequency goes back to its previous operating frequency, which is 154-kHz.

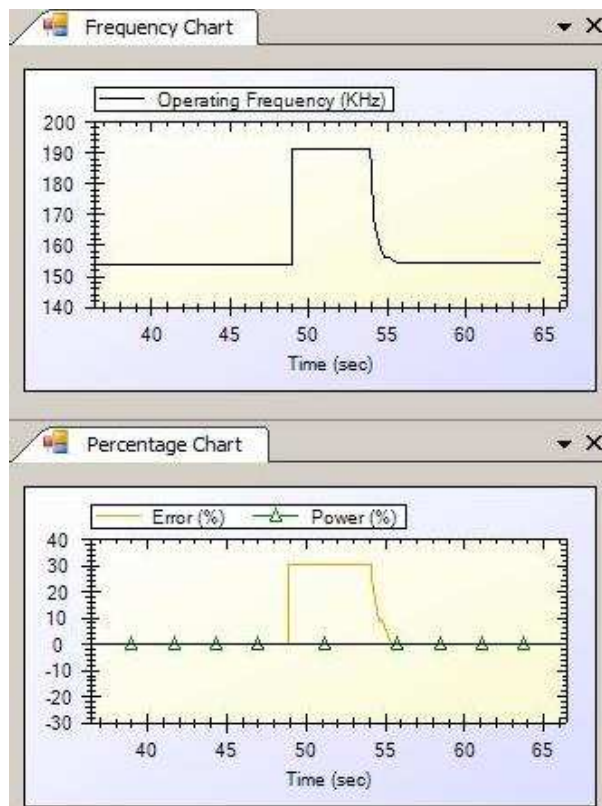
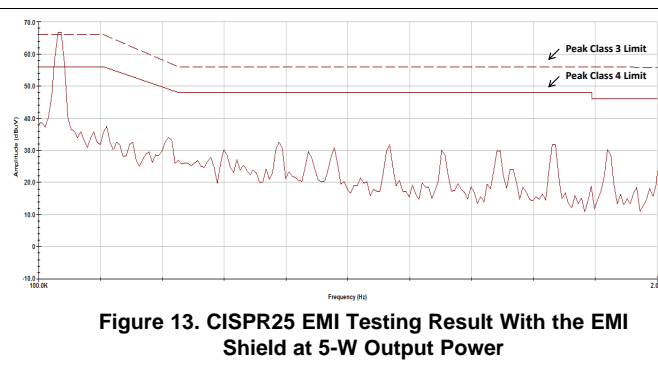
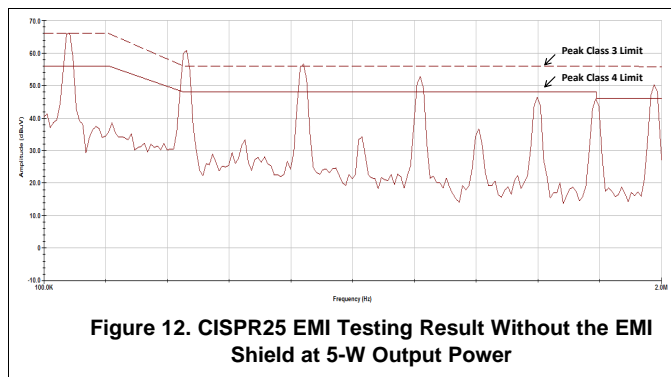

Figure 11. Qi Sniffer Capture of Frequency Shift Operation

## Typical Application (continued)

bq500414Q EVM is tested per CISPR25 EMI specification with and without the EMI shield. The measurement results show > 24-dB improvement with the EMI shield at 5-W output power.



## 10 Power Supply Recommendations

The device is designed to operate from an input voltage supply range between 3.0-V to 3.6-V, nominal 3.3-V. The A6 Tx type requires 12-V system voltage. TPS40210 SEPIC converter is recommend to work with 6-V to 16-V input.

## 11 Layout

### 11.1 Layout Guidelines

Careful PCB layout practice is critical to proper system operation. There are many references on proper PCB layout techniques. A few good tips are as follows:

The Tx layout requires a 4-layer PCB layout for best ground plane technique. A 2-layer PCB layout can be achieved though not as easily. Ideally, the approach to the layer stack-up has been:

- Layer 1 component placement and as much ground plane as possible
- Layer 2 clean ground
- Layer 3 finish routing
- Layer 4 clean ground

Thus, the circuitry is virtually sandwiched between grounds. This minimizes EMI noise emissions and also provides a noise free voltage reference plane for device operation.

Keep as much copper as possible. Make sure the bq500414Q GND pins and the EPAD GND power pad have a continuous flood connection to the ground plane. The power pad should also be stitched to the ground plane, which also acts as a heat sink for the bq500414Q. A good GND reference is necessary for proper bq500414Q operation, such as analog-digital conversion, clock stability and best overall EMI performance.

Separate the analog ground plane from the power ground plane and use only ONE tie point to connect grounds. Having several tie points defeats the purpose of separating the grounds.

The COMM return signal from the resonant tank should be routed as a differential pair. This is intended to reduce stray noise induction. The frequencies of concern warrant low-noise analog signaling techniques, such as differential routing and shielding, but the COMM signal lines do not need to be impedance matched.

The DC-DC buck regulator used from the 12-V input supplies the bq500414Q with 3.3-V. Typically a single-chip controller solution with integrated power FET and synchronous rectifier or outboard diode is used. Pull in the buck inductor and power loop as close as possible to create a tight loop. Likewise, the power-train, full-bridge components should be pulled together as tight as possible. See the bq500414Q EVM for an example of a good layout technique.

## 11.2 Layout Example

A DC-DC buck regulator is used to step down the system voltage to the 3.3-V supply to the bq500414Q. The system voltage could be 12-V, or 6-V – 16-V depending on where the buck regulator input is. With such a step-down ratio, switching duty-cycle will be low and the regulator will be mostly freewheeling. Therefore, place the freewheeling diode current loop as close to the switching regulator as possible (loop in red). Place the buck inductor and power loop as close to that as possible (loop in blue).

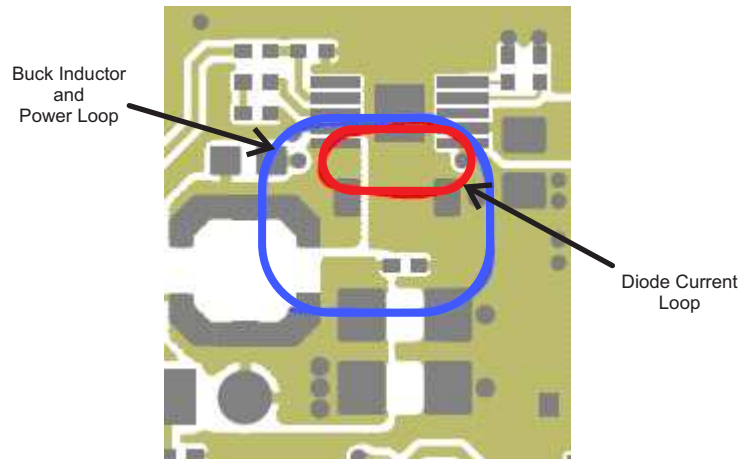

**Figure 14. DC-DC Buck Regulator Layout**

Make sure the bypass capacitors intended for the bq500414Q 3.3-V supply are actually bypassing these supply pins (pin 33 V33D and pin 34 V33A) to solid ground plane. This means they need to be placed as close to the device as possible and the traces must be as wide as possible.

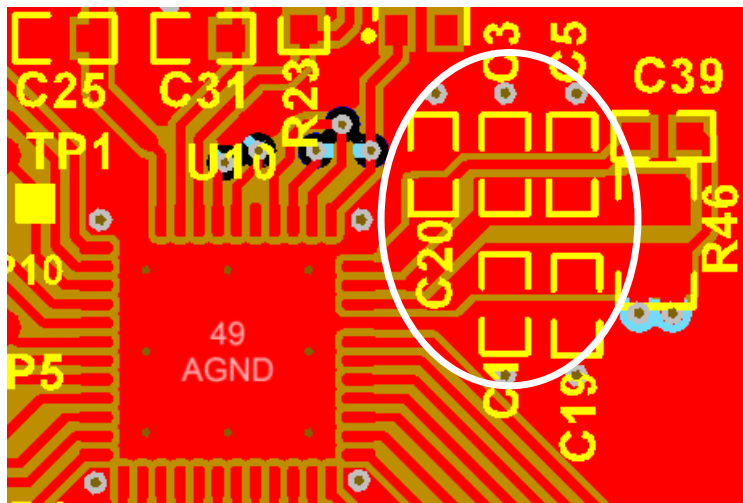

**Figure 15. Bypass Capacitors Layout**

Make sure the bq500414Q has a continuous flood connection to the ground plane.

Layout Example (continued)

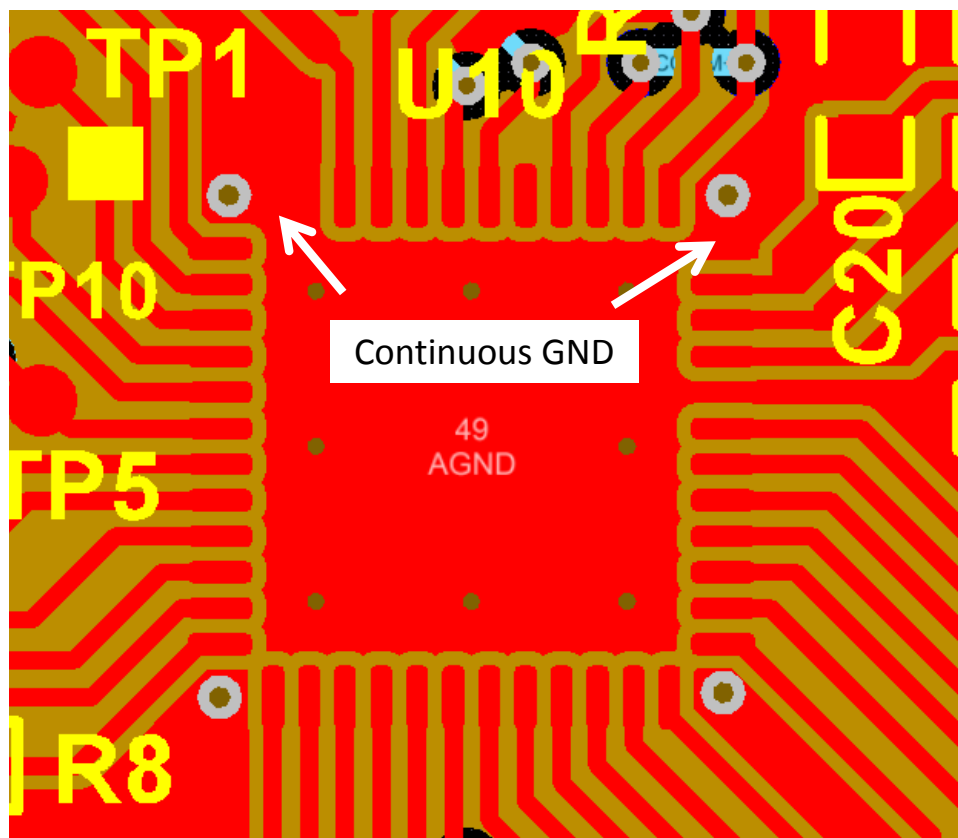
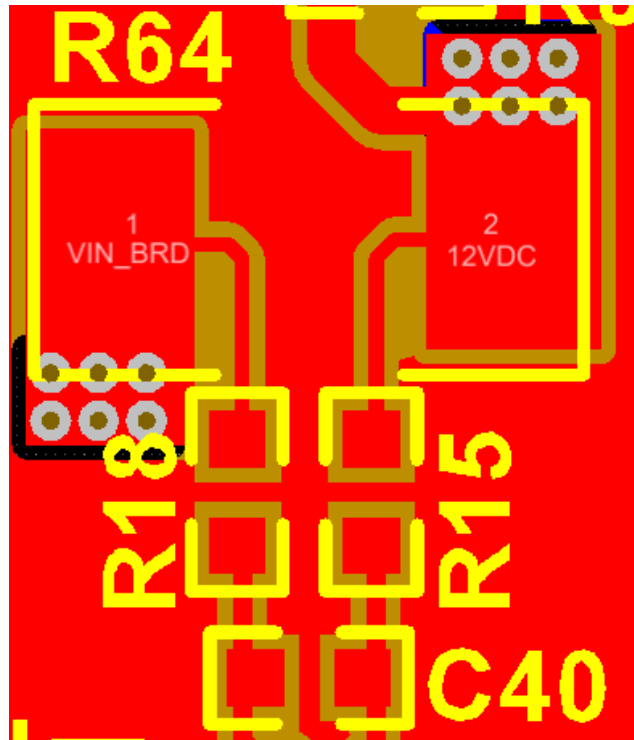

Figure 16. Continuous GND Layout

Proper current sensing layout technique is very important, as it directly affects the FOD and PMOD performance. When sampling the very low voltages generated across a current sense resistor, be sure to use the so called, "Four-wire" or "Kelvin-connection" technique. This is important to avoid introducing false voltage drops from adjacent pads and copper power routes. It is common power supply layout technique.

In the below screen shot of a Texas Instruments PCB layout, the current sense resistor is R64. Notice the R18 and R15 sensing resistors are connected to the pads of R64 so there is no measurement error introduced by copper conduction losses or copper resistance temperature dependency.

**Layout Example (continued)**

**Figure 17. Current Sensing Layout**

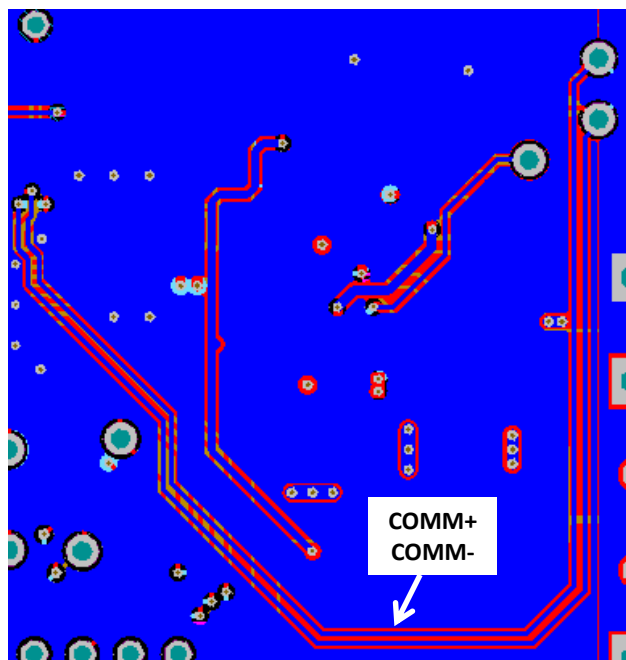
COMM+/COMM– sense lines should be run as a balanced or differential pair. The WPC packet information runs at 2-kHz, which is essential audio frequency content and this balancing reduces noise pickup from the surrounding switching power electronics. There is no need to tune or impedance-match these lines as would be the case in RF signaling.

**Figure 18. Balanced COMM Lines Layout**

## 12 Device and Documentation Support

### 12.1 Device Support

1. Technology, *Wireless Power Consortium*, <http://www.wirelesspowerconsortium.com/>
2. Analog Applications Journal, *An Introduction to the Wireless Power Consortium Standard and TI's Compliant Solutions*, Johns, Bill, (Texas Instruments Literature Number SLYT401)
3. Datasheet, *Qi Compliant Wireless Power Transmitter Manager*, (Texas Instruments Literature Number SLUSAL8)
4. Datasheet, *Integrated Wireless Power Supply Receiver, Qi (WPC) Compliant, bq51011, bq51013*, (Texas Instruments Literature Number SLVSAT9)
5. Application Note, *Building a Wireless Power Transmitter*, (Texas Instruments Literature Number SLUA635)
6. Application Note, *bqTESLA Transmitter Coil Vendors*, (Texas Instruments Literature Number SLUA649)

### 12.2 Trademarks

All trademarks are the property of their respective owners.

### 12.3 Electrostatic Discharge Caution



These devices have limited built-in ESD protection. The leads should be shorted together or the device placed in conductive foam during storage or handling to prevent electrostatic damage to the MOS gates.

### 12.4 Glossary

[SLYZ022](#) — *TI Glossary*.

This glossary lists and explains terms, acronyms, and definitions.

## 13 Mechanical, Packaging, and Orderable Information

The following pages include mechanical packaging and orderable information. This information is the most current data available for the designated devices. This data is subject to change without notice and revision of this document. For browser-based versions of this data sheet, refer to the left-hand navigation.

**PACKAGING INFORMATION**

Orderable Device	Status (1)	Package Type	Package Drawing	Pins	Package Qty	Eco Plan (2)	Lead/Ball Finish (6)	MSL Peak Temp (3)	Op Temp (°C)	Device Marking (4/5)	Samples
BQ500414QRGZRQ1	NRND	VQFN	RGZ	48	2500	Green (RoHS & no Sb/Br)	CU NIPDAU	Level-3-260C-168 HR	-40 to 110	BQ500414Q	
BQ500414QRGZTQ1	NRND	VQFN	RGZ	48	250	Green (RoHS & no Sb/Br)	CU NIPDAU	Level-3-260C-168 HR	-40 to 110	BQ500414Q	

(1) The marketing status values are defined as follows:

**ACTIVE:** Product device recommended for new designs.

**LIFEBUY:** TI has announced that the device will be discontinued, and a lifetime-buy period is in effect.

**NRND:** Not recommended for new designs. Device is in production to support existing customers, but TI does not recommend using this part in a new design.

**PREVIEW:** Device has been announced but is not in production. Samples may or may not be available.

**OBsolete:** TI has discontinued the production of the device.

(2) Eco Plan - The planned eco-friendly classification: Pb-Free (RoHS), Pb-Free (RoHS Exempt), or Green (RoHS & no Sb/Br) - please check <http://www.ti.com/productcontent> for the latest availability information and additional product content details.

**TBD:** The Pb-Free/Green conversion plan has not been defined.

**Pb-Free (RoHS):** TI's terms "Lead-Free" or "Pb-Free" mean semiconductor products that are compatible with the current RoHS requirements for all 6 substances, including the requirement that lead not exceed 0.1% by weight in homogeneous materials. Where designed to be soldered at high temperatures, TI Pb-Free products are suitable for use in specified lead-free processes.

**Pb-Free (RoHS Exempt):** This component has a RoHS exemption for either 1) lead-based flip-chip solder bumps used between the die and package, or 2) lead-based die adhesive used between the die and leadframe. The component is otherwise considered Pb-Free (RoHS compatible) as defined above.

**Green (RoHS & no Sb/Br):** TI defines "Green" to mean Pb-Free (RoHS compatible), and free of Bromine (Br) and Antimony (Sb) based flame retardants (Br or Sb do not exceed 0.1% by weight in homogeneous material)

(3) MSL, Peak Temp. - The Moisture Sensitivity Level rating according to the JEDEC industry standard classifications, and peak solder temperature.

(4) There may be additional marking, which relates to the logo, the lot trace code information, or the environmental category on the device.

(5) Multiple Device Markings will be inside parentheses. Only one Device Marking contained in parentheses and separated by a "~" will appear on a device. If a line is indented then it is a continuation of the previous line and the two combined represent the entire Device Marking for that device.

(6) Lead/Ball Finish - Orderable Devices may have multiple material finish options. Finish options are separated by a vertical ruled line. Lead/Ball Finish values may wrap to two lines if the finish value exceeds the maximum column width.

**Important Information and Disclaimer:** The information provided on this page represents TI's knowledge and belief as of the date that it is provided. TI bases its knowledge and belief on information provided by third parties, and makes no representation or warranty as to the accuracy of such information. Efforts are underway to better integrate information from third parties. TI has taken and continues to take reasonable steps to provide representative and accurate information but may not have conducted destructive testing or chemical analysis on incoming materials and chemicals. TI and TI suppliers consider certain information to be proprietary, and thus CAS numbers and other limited information may not be available for release.

In no event shall TI's liability arising out of such information exceed the total purchase price of the TI part(s) at issue in this document sold by TI to Customer on an annual basis.

## TAPE AND REEL INFORMATION



### QUADRANT ASSIGNMENTS FOR PIN 1 ORIENTATION IN TAPE



\*All dimensions are nominal

Device	Package Type	Package Drawing	Pins	SPQ	Reel Diameter (mm)	Reel Width W1 (mm)	A0 (mm)	B0 (mm)	K0 (mm)	P1 (mm)	W (mm)	Pin1 Quadrant
BQ500414QRGZRQ1	VQFN	RGZ	48	2500	330.0	16.4	7.3	7.3	1.5	12.0	16.0	Q2
BQ500414QRGZTQ1	VQFN	RGZ	48	250	180.0	16.4	7.3	7.3	1.5	12.0	16.0	Q2

**TAPE AND REEL BOX DIMENSIONS**



\*All dimensions are nominal

Device	Package Type	Package Drawing	Pins	SPQ	Length (mm)	Width (mm)	Height (mm)
BQ500414QRGZRQ1	VQFN	RGZ	48	2500	367.0	367.0	38.0
BQ500414QRGZTQ1	VQFN	RGZ	48	250	210.0	185.0	35.0

## GENERIC PACKAGE VIEW

**RGZ 48**

**VQFN - 1 mm max height**

7 x 7, 0.5 mm pitch

PLASTIC QUADFLAT PACK- NO LEAD

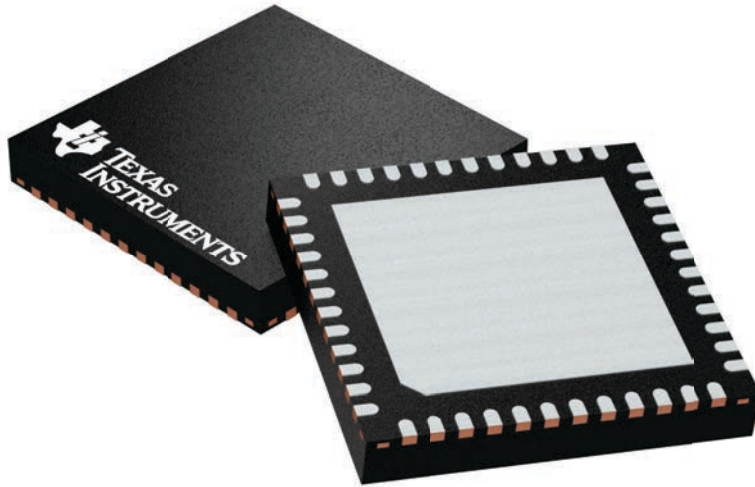

Images above are just a representation of the package family, actual package may vary.  
Refer to the product data sheet for package details.

4224671/A

RGZ0048H

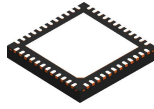

PACKAGE OUTLINE

VQFN - 1 mm max height

PLASTIC QUAD FLATPACK - NO LEAD

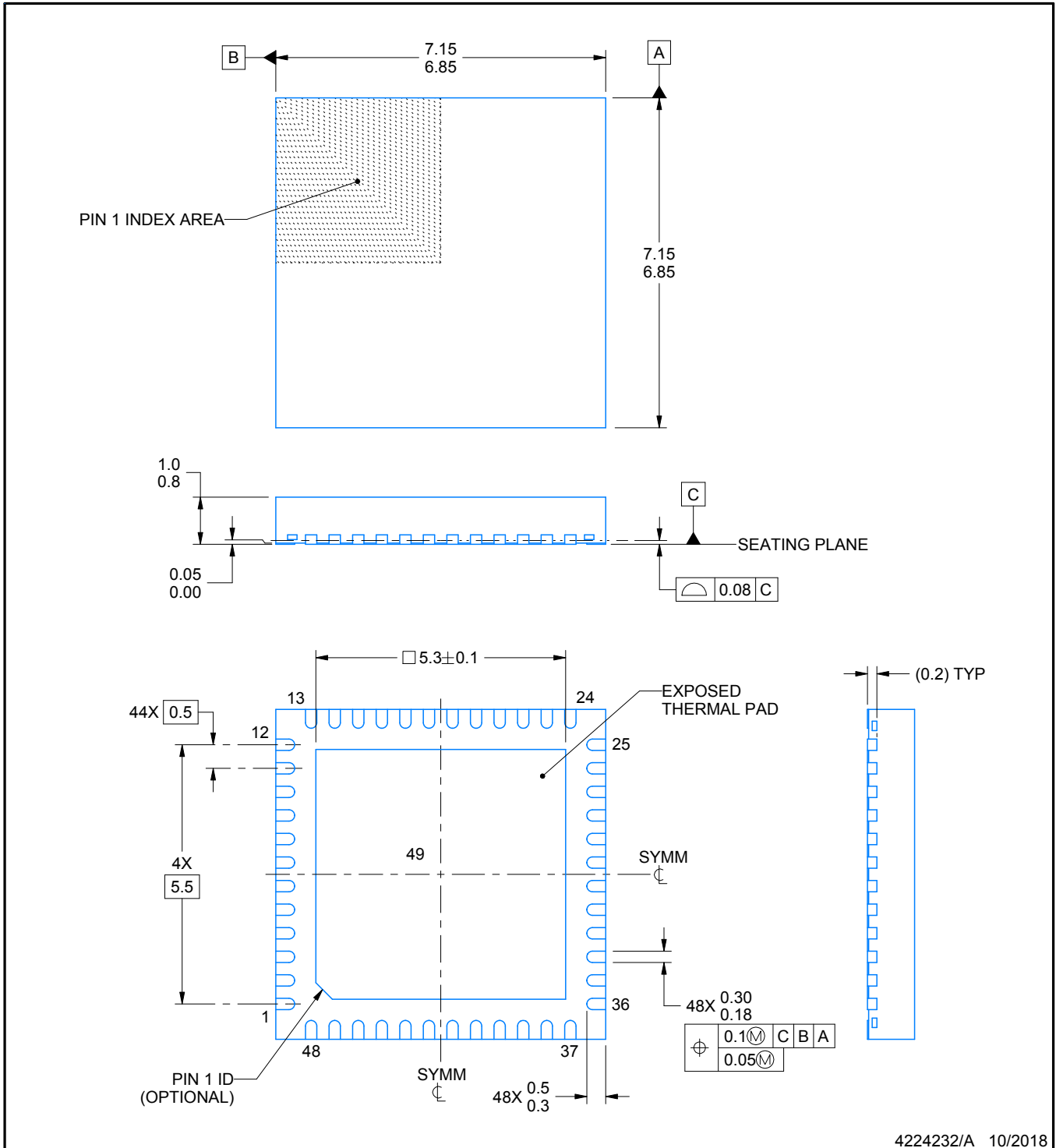

4224232/A 10/2018

NOTES:

1. All linear dimensions are in millimeters. Any dimensions in parenthesis are for reference only. Dimensioning and tolerancing per ASME Y14.5M.
2. This drawing is subject to change without notice.
3. The package thermal pad must be soldered to the printed circuit board for thermal and mechanical performance.

# EXAMPLE BOARD LAYOUT

RGZ0048H

VQFN - 1 mm max height

PLASTIC QUAD FLATPACK - NO LEAD

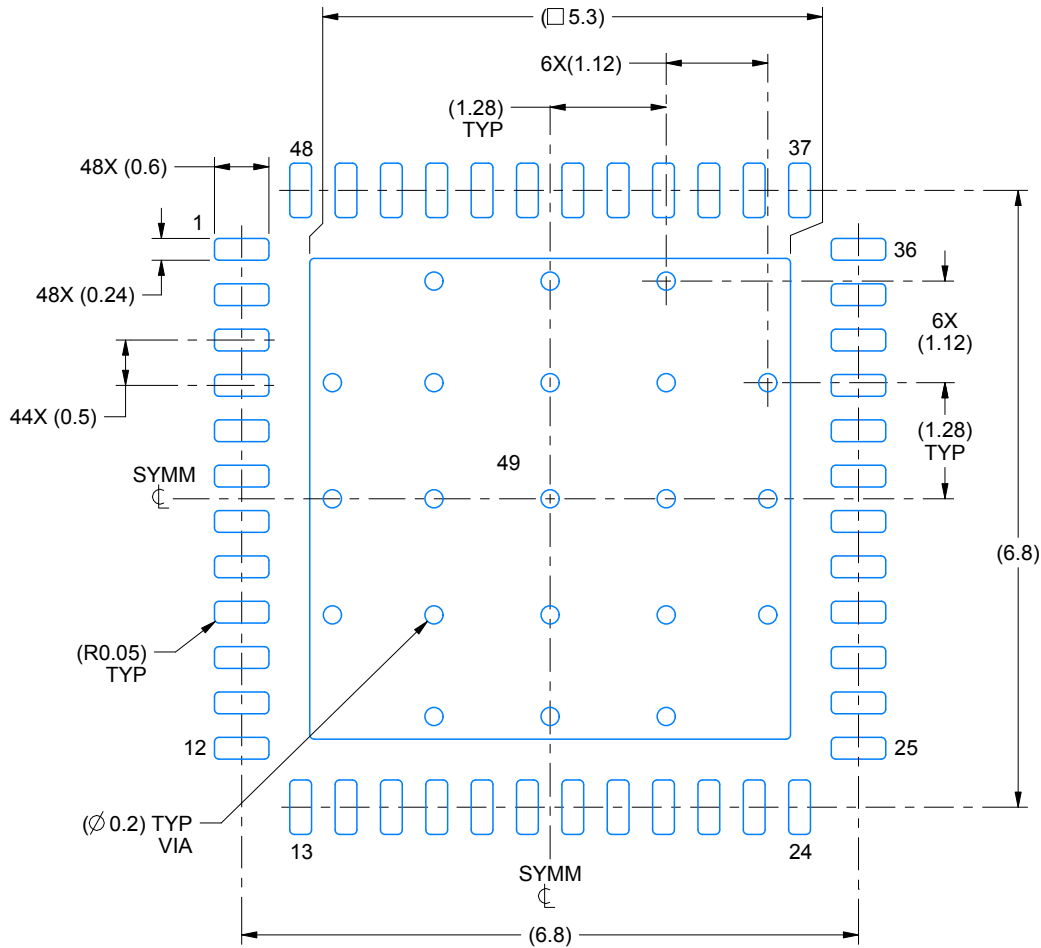

LAND PATTERN EXAMPLE  
EXPOSED METAL SHOWN  
SCALE:12X

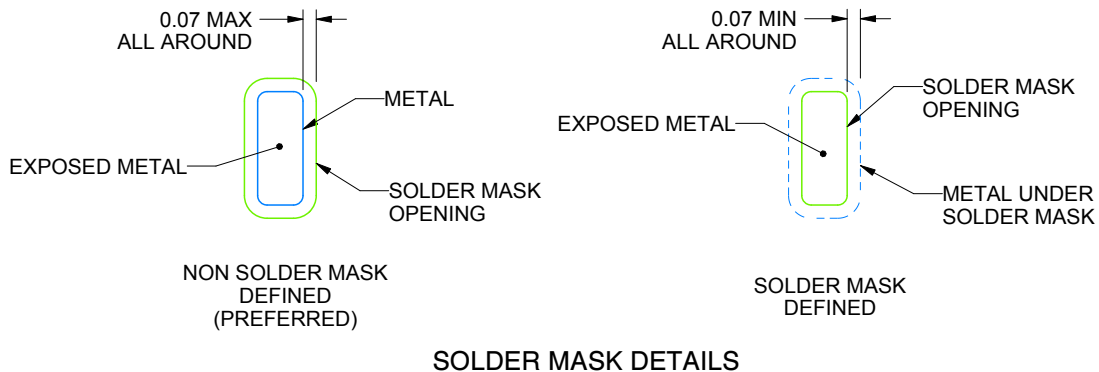

SOLDER MASK DETAILS

4224232/A 10/2018

NOTES: (continued)

- This package is designed to be soldered to a thermal pad on the board. For more information, see Texas Instruments literature number SLUA271 ([www.ti.com/lit/slua271](http://www.ti.com/lit/slua271)).
- Vias are optional depending on application, refer to device data sheet. If any vias are implemented, refer to their locations shown on this view. It is recommended that vias under paste be filled, plugged or tented.

# EXAMPLE STENCIL DESIGN

RGZ0048H

VQFN - 1 mm max height

PLASTIC QUAD FLATPACK - NO LEAD

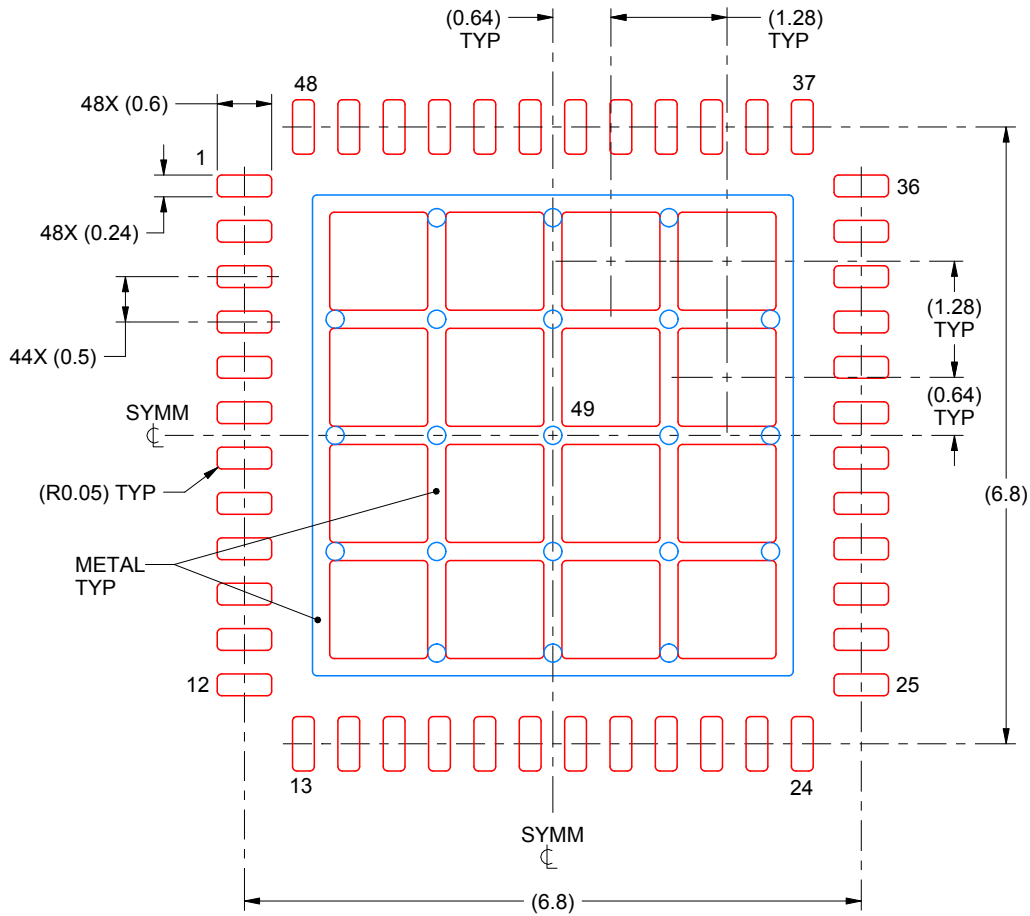

SOLDER PASTE EXAMPLE  
BASED ON 0.125 mm THICK STENCIL

EXPOSED PAD 49  
73% PRINTED SOLDER COVERAGE BY AREA UNDER PACKAGE  
SCALE:12X

4224232/A 10/2018

NOTES: (continued)

6. Laser cutting apertures with trapezoidal walls and rounded corners may offer better paste release. IPC-7525 may have alternate design recommendations.

## IMPORTANT NOTICE AND DISCLAIMER

TI PROVIDES TECHNICAL AND RELIABILITY DATA (INCLUDING DATASHEETS), DESIGN RESOURCES (INCLUDING REFERENCE DESIGNS), APPLICATION OR OTHER DESIGN ADVICE, WEB TOOLS, SAFETY INFORMATION, AND OTHER RESOURCES "AS IS" AND WITH ALL FAULTS, AND DISCLAIMS ALL WARRANTIES, EXPRESS AND IMPLIED, INCLUDING WITHOUT LIMITATION ANY IMPLIED WARRANTIES OF MERCHANTABILITY, FITNESS FOR A PARTICULAR PURPOSE OR NON-INFRINGEMENT OF THIRD PARTY INTELLECTUAL PROPERTY RIGHTS.

These resources are intended for skilled developers designing with TI products. You are solely responsible for (1) selecting the appropriate TI products for your application, (2) designing, validating and testing your application, and (3) ensuring your application meets applicable standards, and any other safety, security, or other requirements. These resources are subject to change without notice. TI grants you permission to use these resources only for development of an application that uses the TI products described in the resource. Other reproduction and display of these resources is prohibited. No license is granted to any other TI intellectual property right or to any third party intellectual property right. TI disclaims responsibility for, and you will fully indemnify TI and its representatives against, any claims, damages, costs, losses, and liabilities arising out of your use of these resources.

TI's products are provided subject to TI's Terms of Sale ([www.ti.com/legal/termsofsale.html](http://www.ti.com/legal/termsofsale.html)) or other applicable terms available either on [ti.com](http://ti.com) or provided in conjunction with such TI products. TI's provision of these resources does not expand or otherwise alter TI's applicable warranties or warranty disclaimers for TI products.

Mailing Address: Texas Instruments, Post Office Box 655303, Dallas, Texas 75265  
Copyright © 2019, Texas Instruments Incorporated

## Looking for pricing, stock, or lifecycle information?

Click below to explore more details on WIN SOURCE:

 [View BQ500414QRGZTQ1](#) on WIN SOURCE

 [Texas Instruments](#) Information

## Optimize Your Supply Chain with WIN SOURCE Solutions

-  Global Sourcing Solution
-  Obsolete Management
-  Cost Control Management
-  Shortage Management
-  Alternative Solution
-  Excess Inventory Management