



**THE DATASHEET OF
TCS37715FN**



TCS3771

Color Light-To-Digital Converter with Proximity Sensing

General Description

The TCS3771 family of devices provides red, green, blue, and clear (RGBC) light sensing and proximity detection (when coupled with an external IR LED). They detect light intensity under a variety of lighting conditions and through a variety of attenuation materials. The proximity detection feature allows a large dynamic range of operation for use in short distance detection behind dark glass such as in a cell phone or for longer distance measurements for applications such as presence detection for monitors or laptops. The programmable proximity detection enables continuous measurements across the entire range. In addition, an internal state machine provides the ability to put the device into a low power mode in between RGBC and proximity measurements providing very low average power consumption.

The TCS3771 is directly useful in lighting conditions containing minimal IR content such as LED RGB backlight control, reflected LED color sampler, or fluorescent light color temperature detector. With the addition of an IR blocking filter, the device is an excellent ambient light sensor, color temperature monitor, and general purpose color sensor.

The proximity function is targeted specifically towards battery-powered mobile devices, LCD monitor, laptop, and flat-panel television applications. In cell phones, the proximity detection can detect when the user positions the phone close to their ear. The device is fast enough to provide proximity information at a high repetition rate needed when answering a phone call. It can also detect both close and far distances so the application can implement more complex algorithms to provide a more robust interface. In laptop or monitor applications, the product is sensitive enough to determine whether a user is in front of the laptop using the keyboard or away from the desk. This provides both improved *green* power saving capability and the added security to lock the computer when the user is not present.

Ordering Information and Content Guide appear at end of datasheet.

Key Benefits & Features

The benefits and features of the TCS3771 are listed below:

Figure 1:
Added Value of using TCS3771

Benefits	Features
<ul style="list-style-type: none"> • Single Device reduces board space 	<ul style="list-style-type: none"> • RGB Color Sensing and Proximity Detection in a Single Device
<ul style="list-style-type: none"> • Enables both Correlated Color Temperature and Ambient Light Sensing across wide range of lighting condition applications 	<ul style="list-style-type: none"> • Color Light Sensing <ul style="list-style-type: none"> • Programmable Analog Gain, Integration Time, and Interrupt Function with Upper and Lower Thresholds • Resolution Up to 16 bits • Very High Sensitivity - Ideally Suited for Operation Behind Dark Glass • Up to 1,000,000:1 Dynamic Range
<ul style="list-style-type: none"> • Enables versatile Infra-red proximity based object detection 	<ul style="list-style-type: none"> • Proximity Detection <ul style="list-style-type: none"> • Programmable Number of IR Pulses, Current Sink for the IR LED - No Limiting Resistor Needed, and Interrupt Function with Upper and Lower Thresholds • Covers a 2000:1 Dynamic Range
<ul style="list-style-type: none"> • Low power wait state programmability reduces average power consumption 	<ul style="list-style-type: none"> • Low Power Wait State <ul style="list-style-type: none"> • 65µA Typical Current • Wait Timer is Programmable from 2.4ms to > 7 seconds
<ul style="list-style-type: none"> • Digital interfaces are less susceptible to noise 	<ul style="list-style-type: none"> • I²C Interface Compatible <ul style="list-style-type: none"> • Up to 400kHz (I²C Fast Mode)
<ul style="list-style-type: none"> • Reduces micro-processor Interrupt Overhead with both up persist and no-persist interrupt thresholds 	<ul style="list-style-type: none"> • Dedicated Interrupt Pin
<ul style="list-style-type: none"> • Enables drop-in and foot-print compatible solutions 	<ul style="list-style-type: none"> • Pin and Register Set Compatible with the TCS3x7x Family of Devices
<ul style="list-style-type: none"> • Reduces board space requirements while simplifying designs 	<ul style="list-style-type: none"> • Small 2mm × 2.4mm Dual Flat No-Lead Package
<ul style="list-style-type: none"> • Low power sleep state reduces average power consumption 	<ul style="list-style-type: none"> • Sleep Mode - 2.5µA Typical Current

Applications

The applications of TCS3771 include:

- RGB LED Backlight Control
- Ambient Color Temperature Sensing
- Cell Phone Touch Screen Disable
- Notebook/Monitor Security
- Automatic Menu Popup

- Industrial Process Control
- Medical Diagnostics

End Products and Market Segments

- HDTVs, Mobile Handsets, Tablets, Laptops, Monitors, PMP (Portable Media Players)
- Medical and Commercial Instrumentation
- Consumer Toys
- Industrial/Commercial Lighting

Block Diagram

The functional blocks of this device for reference are shown below:

Figure 2:
TCS3771 Block Diagram

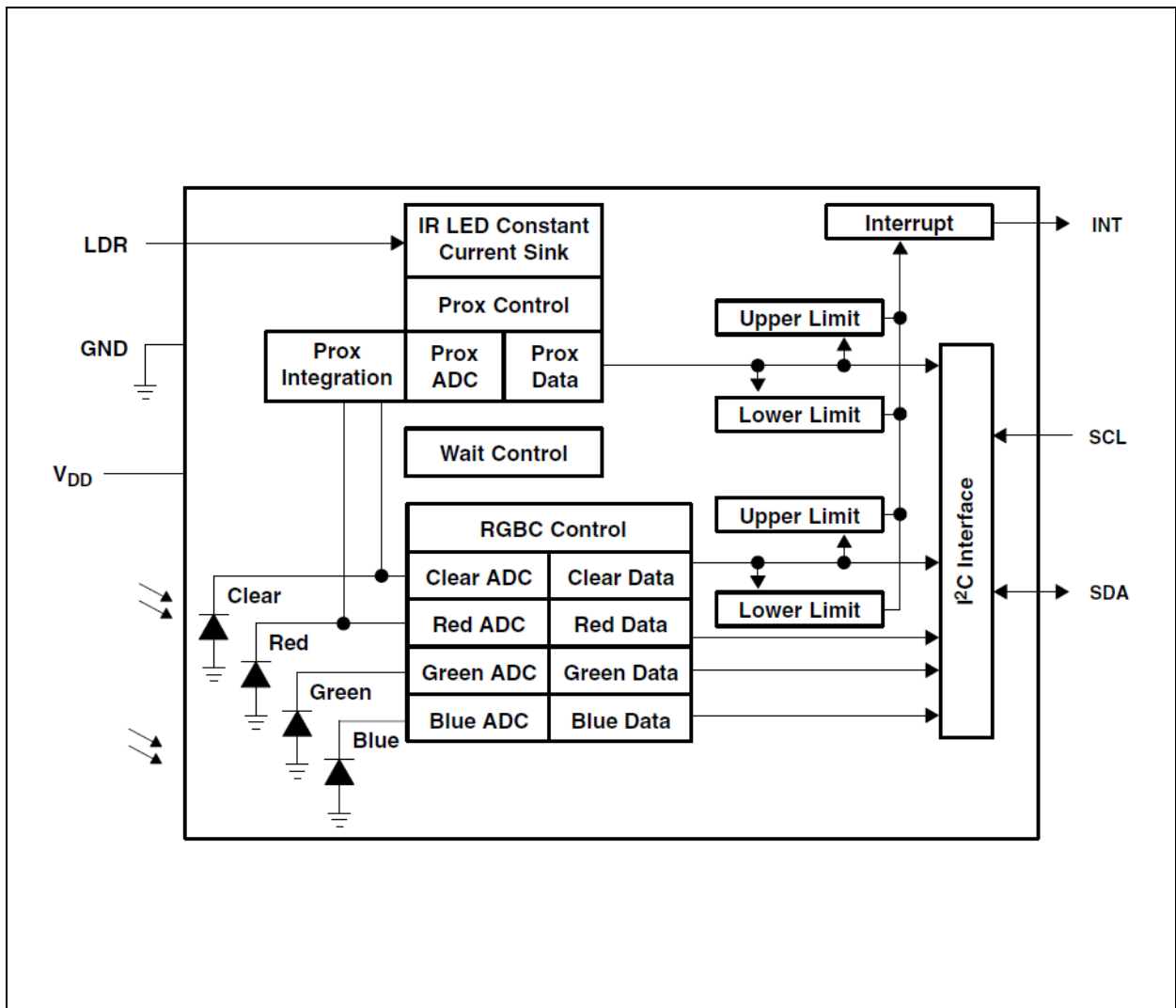

Detailed Description

The TCS3771 light-to-digital device contains a 4 × 4 photodiode array, integrating amplifiers, ADCs, accumulators, clocks, buffers, comparators, a state machine, and an I²C interface. The 4 × 4 photodiode array is composed of red-filtered, green-filtered, blue-filtered, and clear photodiodes - four of each type. Four integrating ADCs simultaneously convert the amplified photodiode currents to a digital value providing up to 16 bits of resolution. Upon completion of the conversion cycle, the conversion result is transferred to the data registers. The transfers are double-buffered to ensure that the integrity of the data is maintained. Communication to the device is accomplished through a fast (up to 400kHz), two-wire I²C serial bus for easy connection to a microcontroller or embedded controller.

The TCS3771 provides a separate pin for level-style interrupts. When interrupts are enabled and a preset value is exceeded, the interrupt pin is asserted and remains asserted until cleared by the controlling firmware. The interrupt feature simplifies and improves system efficiency by eliminating the need to poll a sensor for a light intensity or proximity value. An interrupt is generated when the value of an RGBC or proximity conversion exceeds either an upper or lower threshold. In addition, a programmable interrupt persistence feature allows the user to determine how many consecutive exceeded thresholds are necessary to trigger an interrupt. Interrupt thresholds and persistence settings are configured independently for both RGBC and proximity.

Proximity detection requires only a single external IR LED. An internal LED driver can be configured to provide a constant current sink of 12.5mA, 25mA, 50mA or 100mA of current. No external current limiting resistor is required. The number of proximity LED pulses can be programmed from 1 to 255 pulses. Each pulse has a 14µs period. This LED current coupled with the programmable number of pulses provides a 2000:1 contiguous dynamic range.

Pin Assignments

The TCS3771 pin assignments are described below:

Figure 3:
Pin Diagram of Package FN Dual Flat No-Lead (Top View)

Package drawing not to scale.

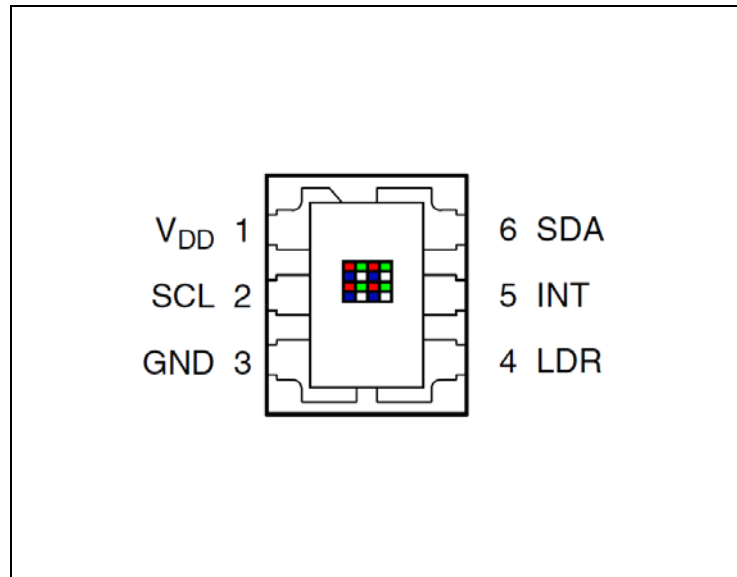

Figure 4:
Terminal Functions

Terminal		Type	Description
Name	No		
V _{DD}	1		Supply voltage
SCL	2	I	I ² C serial clock input terminal - clock signal for I ² C serial data
GND	3		Power supply ground. All voltages are referenced to GND.
LDR	4	O	LED driver for proximity emitter - up to 100mA, open drain
INT	5	O	Interrupt - open drain (active low)
SDA	6	I/O	I ² C serial data I/O terminal - serial data I/O for I ² C

Absolute Maximum Ratings

Stresses beyond those listed under “Absolute Maximum Ratings” may cause permanent damage to the device. These are stress ratings only. Functional operation of the device at these or any other conditions beyond those indicated under [Recommended Operating Conditions](#) is not implied. Exposure to absolute maximum rating conditions for extended periods may affect device reliability.

Figure 5:
Absolute Maximum Ratings over Operating Free-Air Temperature Range (unless otherwise noted)

Symbol	Parameter	Min	Max	Unit
V_{DD}	Supply voltage ⁽¹⁾		3.8	V
V_O	Digital output voltage range	-0.5	3.8	V
I_O	Digital output current	-1	20	mA
T_{stg}	Storage temperature range	-40	85	°C
	ESD tolerance, human body model		2000	V

Note(s):

1. All voltages are with respect to GND.

Electrical Characteristics

All limits are guaranteed. The parameters with min and max values are guaranteed with production tests or SQC (Statistical Quality Control) methods.

Figure 6:
Recommended Operating Conditions

Symbol	Parameter	Min	Nom	Max	Unit
V_{DD}	Supply voltage	2.7	3	3.3	V
T_A	Operating free-air temperature	-30		70	°C

Figure 7:
Operating Characteristics, $V_{DD} = 3V$, $T_A = 25^\circ C$ (unless otherwise noted)

Symbol	Parameter	Test Conditions	Min	Typ	Max	Unit
I_{DD}	Supply current	Active - LDR pulses off		235	330	μA
		Wait mode		65		
		Sleep mode - no I ² C activity		2.5	10	
V_{OL}	INT, SDA output low voltage	3mA sink current	0		0.4	V
		6mA sink current	0		0.6	
I_{LEAK}	Leakage current, SDA, SCL, INT pins		-5		5	μA
I_{LEAK}	Leakage current, LDR pin		-10		+10	μA
V_{IH}	SCL, SDA input high voltage	TCS37715	$0.7 V_{DD}$			V
		TCS37717	1.25			
V_{IL}	SCL, SDA input low voltage	TCS37715			$0.3 V_{DD}$	V
		TCS37717			0.54	

Figure 8:

Optical Characteristics, $V_{DD} = 3V$, $T_A = 25^\circ C$, Gain = 16, ATIME = 0xF6 (unless otherwise noted) ⁽¹⁾

Parameter	Test Conditions	Red Channel			Green Channel			Blue Channel		
		Min	Typ	Max	Min	Typ	Max	Min	Typ	Max
R_e Irradiance responsivity	$\lambda_D = 465nm$, ⁽²⁾	0%		15%	10%		42%	65%		88%
	$\lambda_D = 525nm$, ⁽³⁾	6%		25%	60%		85%	9%		35%
	$\lambda_D = 625nm$, ⁽⁴⁾	85%		110%	0%		15%	5%		25%

Note(s):

1. The percentage shown represents the ratio of the respective red, green, or blue channel value to the clear channel value.
2. The 465nm input irradiance is supplied by an InGaN light-emitting diode with the following characteristics:
dominant wavelength $\lambda_D = 465nm$, spectral halfwidth $\Delta\lambda_{1/2} = 22nm$, and luminous efficacy = 75lm/W.
3. The 525nm input irradiance is supplied by an InGaN light-emitting diode with the following characteristics:
dominant wavelength $\lambda_D = 525nm$, spectral halfwidth $\Delta\lambda_{1/2} = 35nm$, and luminous efficacy = 520lm/W.
4. The 625nm input irradiance is supplied by a AlInGaP light-emitting diode with the following characteristics:
dominant wavelength $\lambda_D = 625nm$, spectral halfwidth $\Delta\lambda_{1/2} = 9nm$, and luminous efficacy = 155lm/W.

Figure 9:
RGBC Characteristics, $V_{DD} = 3V$, $T_A = 25^\circ C$, AGAIN = 16, AEN = 1 (unless otherwise noted)

Parameter	Test Conditions	Min	Typ	Max	Unit
Dark ADC count value	$E_e = 0$, AGAIN = 60x, ATIME = 0xD6 (100ms)	0	1	5	Counts
ADC integration time step size	ATIME = 0xFF	2.27	2.4	2.56	ms
ADC number of integration steps		1		256	Steps
ADC counts per step		0		1024	Counts
ADC count value	ATIME = 0xC0 (153.6ms)	0		65535	Counts
Gain scaling, relative to 1x gain setting	4x	3.8	4	4.2	%
	16x	15	16	16.8	
	60x	58	60	63	

Figure 10:
Proximity Characteristics, $V_{DD} = 3V$, $T_A = 25^\circ C$, Gain = 16, PEN = 1 (unless otherwise noted)

	Parameter	Test Conditions	Condition	Min	Typ	Max	Unit
I_{DD}	Supply current	LDR pulse on			3		mA
	ADC conversion time step size	PTIME = 0xFF		2.27	2.4	2.56	ms
	ADC number of integration steps			1		256	Steps
	ADC counts per step			0		1023	Counts
	IR LED pulse count			0		255	Pulses
	LED pulse period	Two or more pulses			14		μs
	LED pulse width - LED on time				6.3		μs
	LED drive current	I_{SINK} sink current @ 600mV, LDR pin	PDRIVE = 0	80	106	132	mA
PDRIVE = 1				50			
PDRIVE = 2				25			
PDRIVE = 3				12.5			
	Dark count value	$E_e = 0$, PTIME = 0xFB, PPULSE = 2				900	Counts
	Red channel	$\lambda_p = 850nm$, $E_e = 45.3\mu W/cm^2$, PTIME = 0xFB, PPULSE = 2 ⁽¹⁾		1000		3000	Counts
	Clear channel	$\lambda_p = 850nm$, $E_e = 45.3\mu W/cm^2$, PTIME = 0xFB, PPULSE = 2 ⁽¹⁾		1000		3000	Counts
	Operating distance ⁽²⁾				30		Inches

Note(s):

1. The specified light intensity is 100% modulated by the pulse output of the device so that during the pulse output low time, the light intensity is at the specified level, and 0 otherwise.
2. Proximity Operating Distance is dependent upon emitter properties and the reflective properties of the proximity surface. The nominal value shown uses an IR emitter with a peak wavelength of 850nm and a 20° half angle. The proximity surface used is a 90% reflective (white surface) 16 × 20-inch Kodak Gray Card. 60mw/SR, 100mA, 64 pulses, open view (no glass). **Greater distances are achievable with appropriate system considerations.**

Figure 11:
Wait Characteristics, $V_{DD} = 3V$, $T_A = 25^\circ C$, Gain = 16, WEN = 1 (unless otherwise noted)

Parameter	Test Conditions	Channel	Min	Typ	Max	Unit
Wait step size	WTIME = 0xFF		2.27	2.4	2.56	ms
Wait number of steps			1		256	Steps

Figure 12:
AC Electrical Characteristics, $V_{DD} = 3V$, $T_A = 25^\circ C$ (unless otherwise noted)

Symbol	Parameter ⁽¹⁾	Test Conditions	Min	Typ	Max	Unit
$f_{(SCL)}$	Clock frequency (I ² C only)		0		400	kHz
$t_{(BUF)}$	Bus free time between start and stop condition		1.3			μs
$t_{(HDSTA)}$	Hold time after (repeated) start condition. After this period, the first clock is generated.		0.6			μs
$t_{(SUSTA)}$	Repeated start condition setup time		0.6			μs
$t_{(SUSTO)}$	Stop condition setup time		0.6			μs
$t_{(HDDAT)}$	Data hold time		0			μs
$t_{(SUDAT)}$	Data setup time		100			ns
$t_{(LOW)}$	SCL clock low period		1.3			μs
$t_{(HIGH)}$	SCL clock high period		0.6			μs
t_F	Clock/data fall time				300	ns
t_R	Clock/data rise time				300	ns
C_i	Input pin capacitance				10	pF

Note(s):

1. Specified by design and characterization; not production tested.

Typical Characteristics

Figure 14:
Photodiode Spectral Responsivity

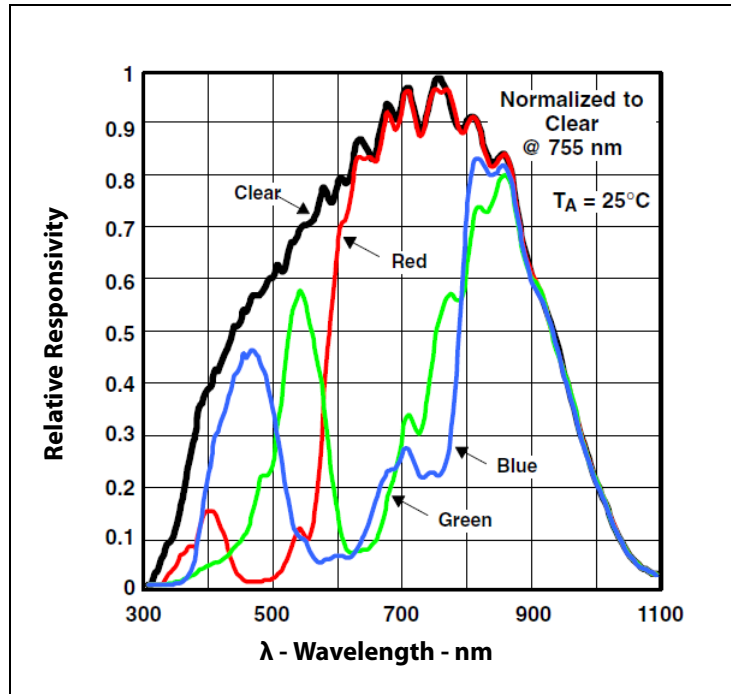

Figure 15:
Typical LDR Current vs. Voltage

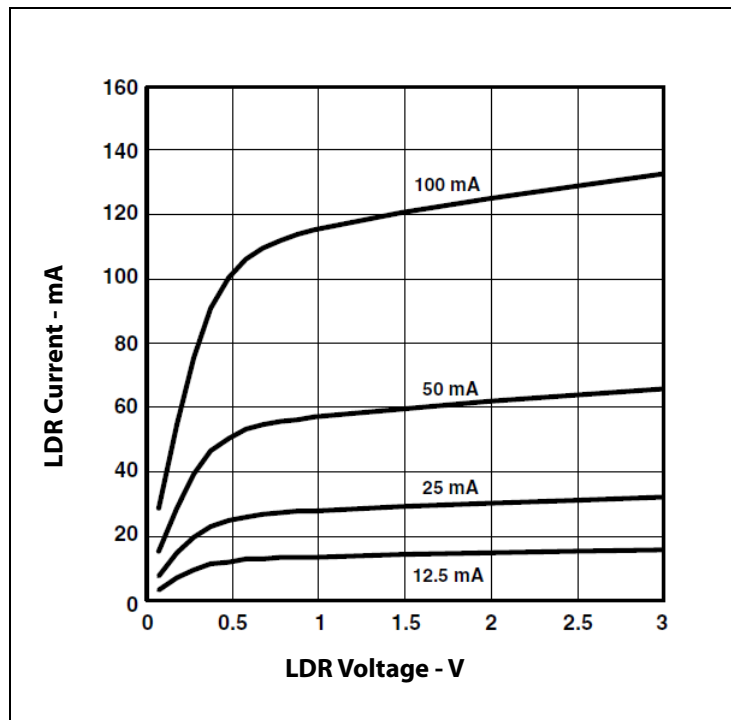

Figure 16:
Normalized I_{DD} vs. V_{DD} and Temperature

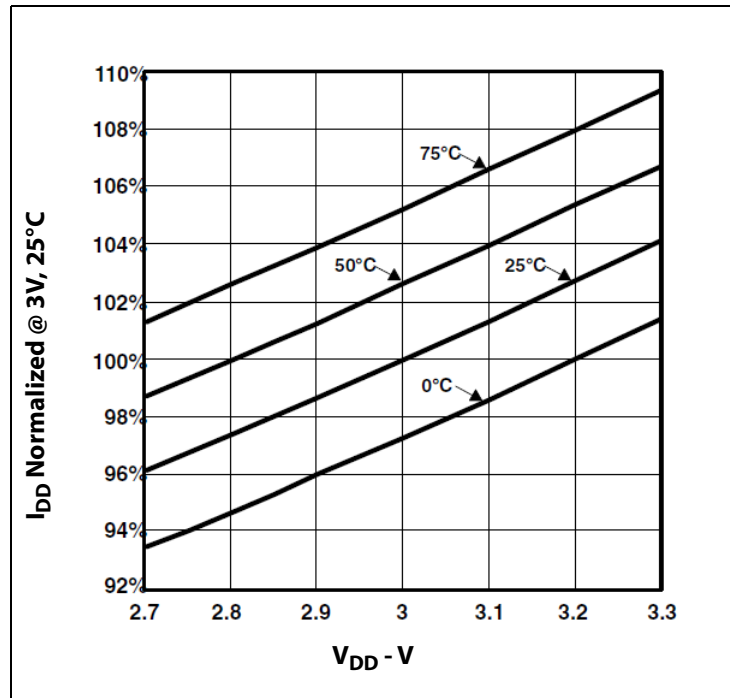

Figure 17:
Normalized Responsivity vs. Angular Displacement

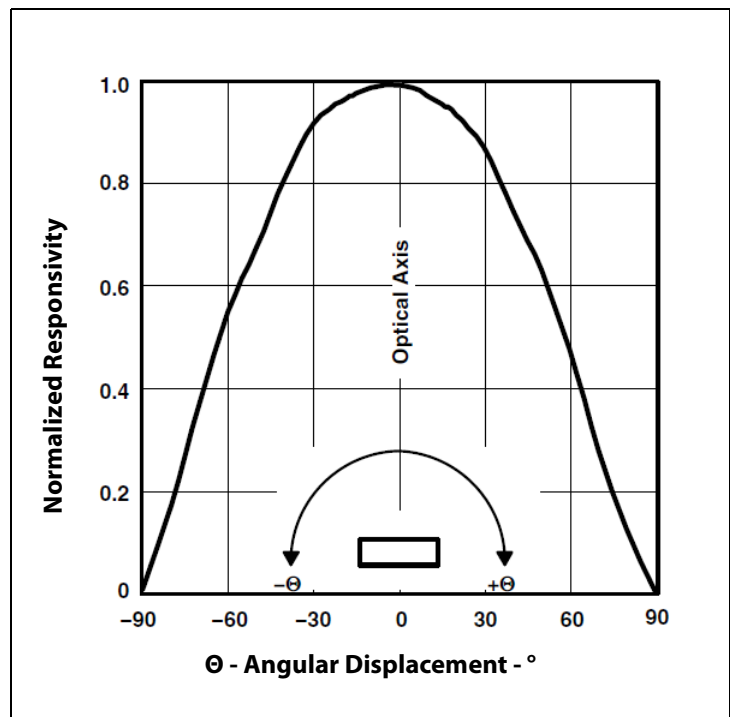
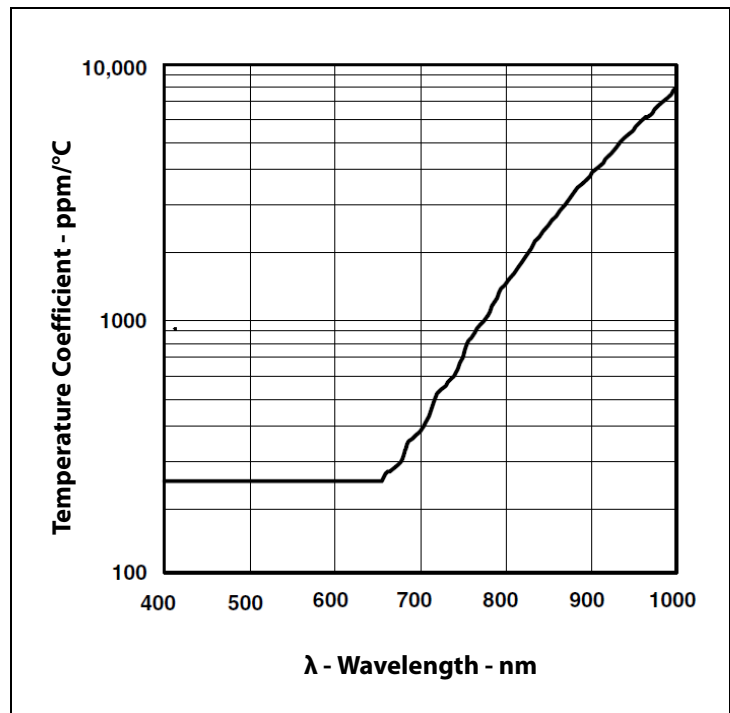

Figure 18:
Responsivity Temperature Coefficient



Principles of Operation

System State Machine

The TCS3771 provides control of RGBC, proximity detection, and power management functionality through an internal state machine (Figure 19). After a power-on-reset, the device is in the sleep mode. As soon as the PON bit is set, the device will move to the start state. It will then continue through the Prox, Wait, and RGBC states. If these states are enabled, the device will execute each function. If the PON bit is set to 0, the state machine will continue until all conversions are completed and then go into a low power sleep mode.

Figure 19:
Simplified State Diagram

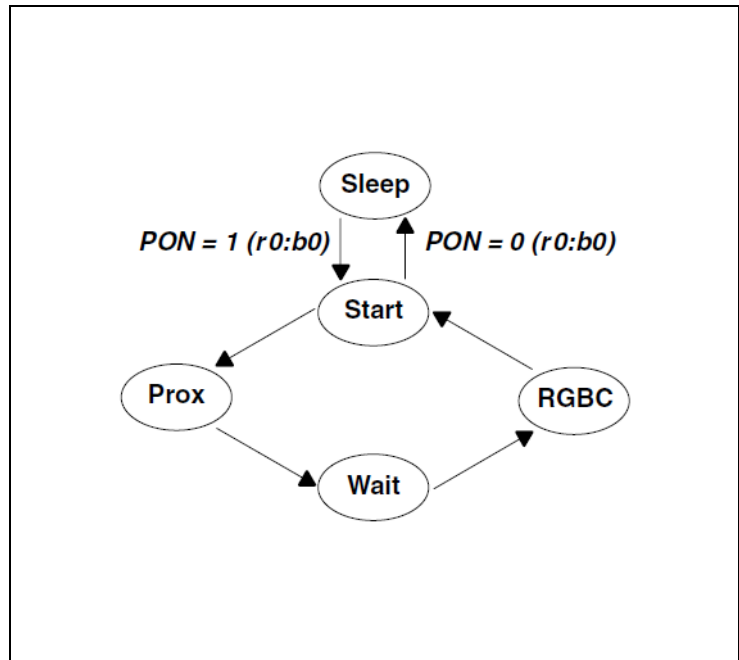

Note(s): In this document, the nomenclature uses the bit field name in italics followed by the register number and bit number to allow the user to easily identify the register and bit that controls the function. For example, the power on (PON) is in register 0, bit 0. This is represented as *PON (r0:b0)*.

RGBC Operation

The RGBC engine contains RGBC gain control (AGAIN) and four integrating analog-to-digital converters (ADC) for the RGBC photodiodes. The RGBC integration time (ATIME) impacts both the resolution and the sensitivity of the RGBC reading. Integration of all four channels occurs simultaneously and upon completion of the conversion cycle, the results are transferred to the color data registers. This data is also referred to as channel count. The transfers are double-buffered to ensure that invalid data is not read during the transfer. After the transfer, the device automatically moves to the next state in accordance with the configured state machine.

Figure 20:
RGBC Operation

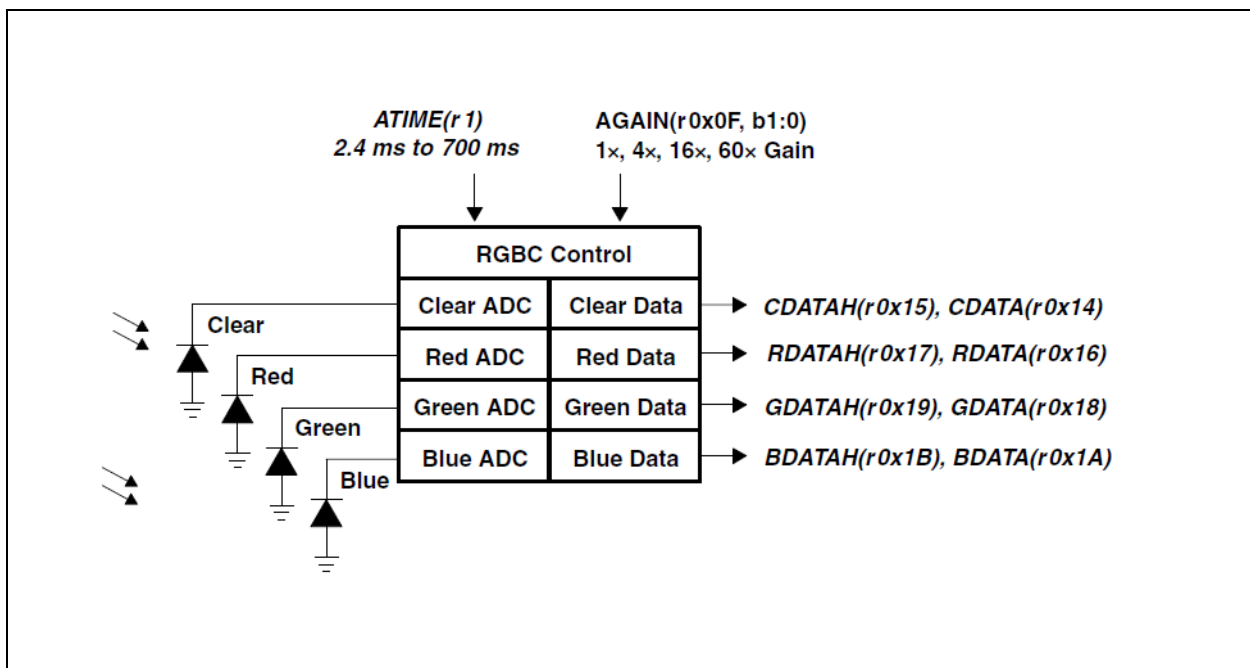

The registers for programming the integration and wait times are a 2's complement values. The actual time can be calculated as follows:

$$ATIME = 256 - \text{Integration Time} / 2.4\text{ms}$$

Inversely, the time can be calculated from the register value as follows:

$$\text{Integration Time} = 2.4\text{ms} \times (256 - ATIME)$$

For example, if a 100-ms integration time is needed, the device needs to be programmed to:

$$256 - (100 / 2.4) = 256 - 42 = 214 = 0xD6$$

Conversely, the programmed value of 0xC0 would correspond to:

$$(256 - 0xC0) \times 2.4 = 64 \times 2.4 = 154\text{ms}$$

Proximity Detection

Proximity sensing uses an external light source (generally an infrared emitter) to emit light, which is then viewed by the integrated light detector to measure the amount of reflected light when an object is in the light path (Figure 21). The amount of light detected from a reflected surface can then be used to determine an object’s proximity to the sensor.

Figure 21:
Proximity Detection

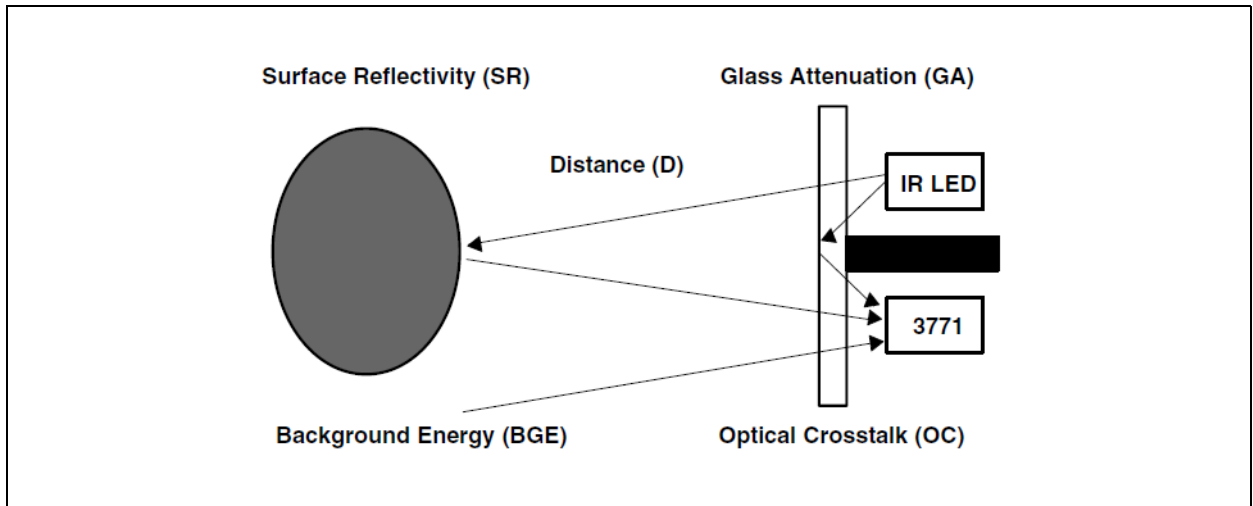

The TCS3771 has controls for the number of IR pulses (PPCOUNT), the integration time (PTIME), the LED drive current (PDRIVE) and the photodiode configuration (PDIODE). The photodiode configuration can be set to red diode (recommended), clear diode, or a combination of both diodes. At the end of the integration cycle, the results are latched into the proximity data (PDATA) register.

Figure 22:
Proximity Detection Operation

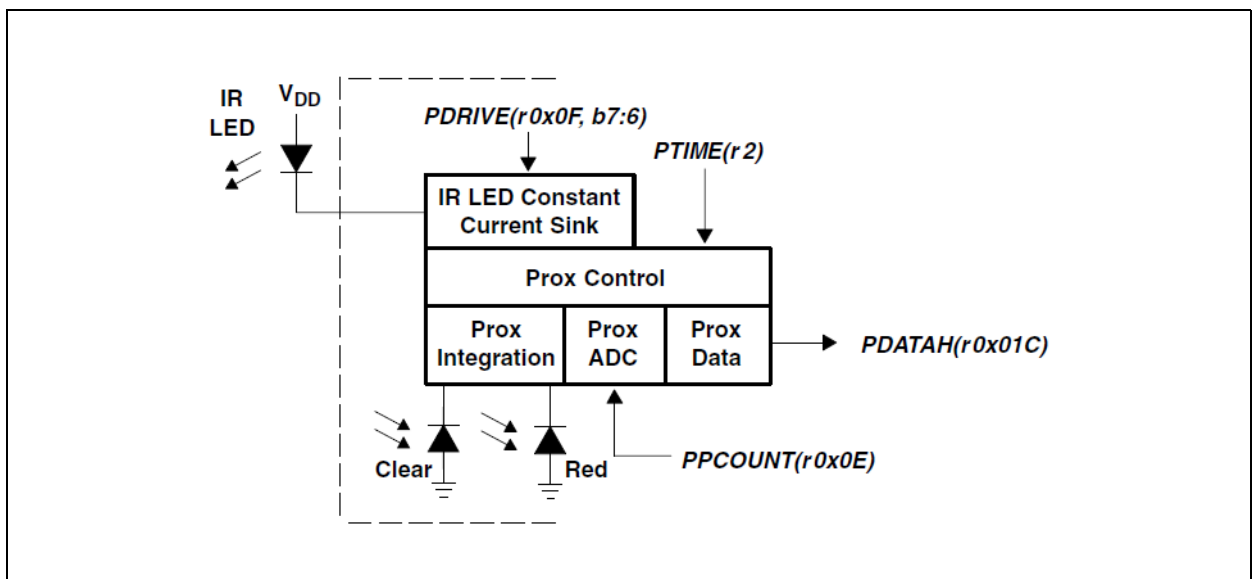

The LED drive current is controlled by a regulated current sink on the LDR pin. This feature eliminates the need to use a current limiting resistor to control LED current. The LED drive current can be configured for 12.5mA, 25mA, 50mA, or 100mA. For higher LED drive requirements, an external P-FET transistor can be used to control the LED current.

The number of LED pulses can be programmed to any value between 1 and 255 pulses as needed. Increasing the number of LED pulses at a given current will increase the sensor sensitivity. Sensitivity grows by the square root of the number of pulses. Each pulse has a 14µs period.

Figure 23:
Proximity IR LED Waveform

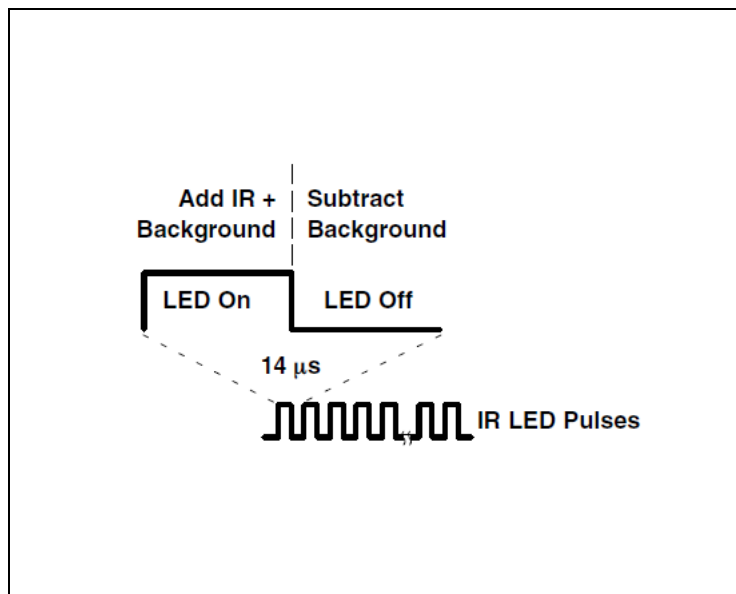

The proximity integration time (PTIME) is the period of time that the internal ADC converts the analog signal to a digital count. It is recommended that this be set to a minimum of PTIME = 0xFF or 2.4ms.

The combination of LED power and number of pulses can be used to control the distance at which the sensor can detect proximity. Figure 24 shows an example of the distances covered with settings such that each curve covers 2x the distance. Counts up to 64 pulses provide a 16x range.

Figure 24:
Proximity ADC Count vs. Relative Distance

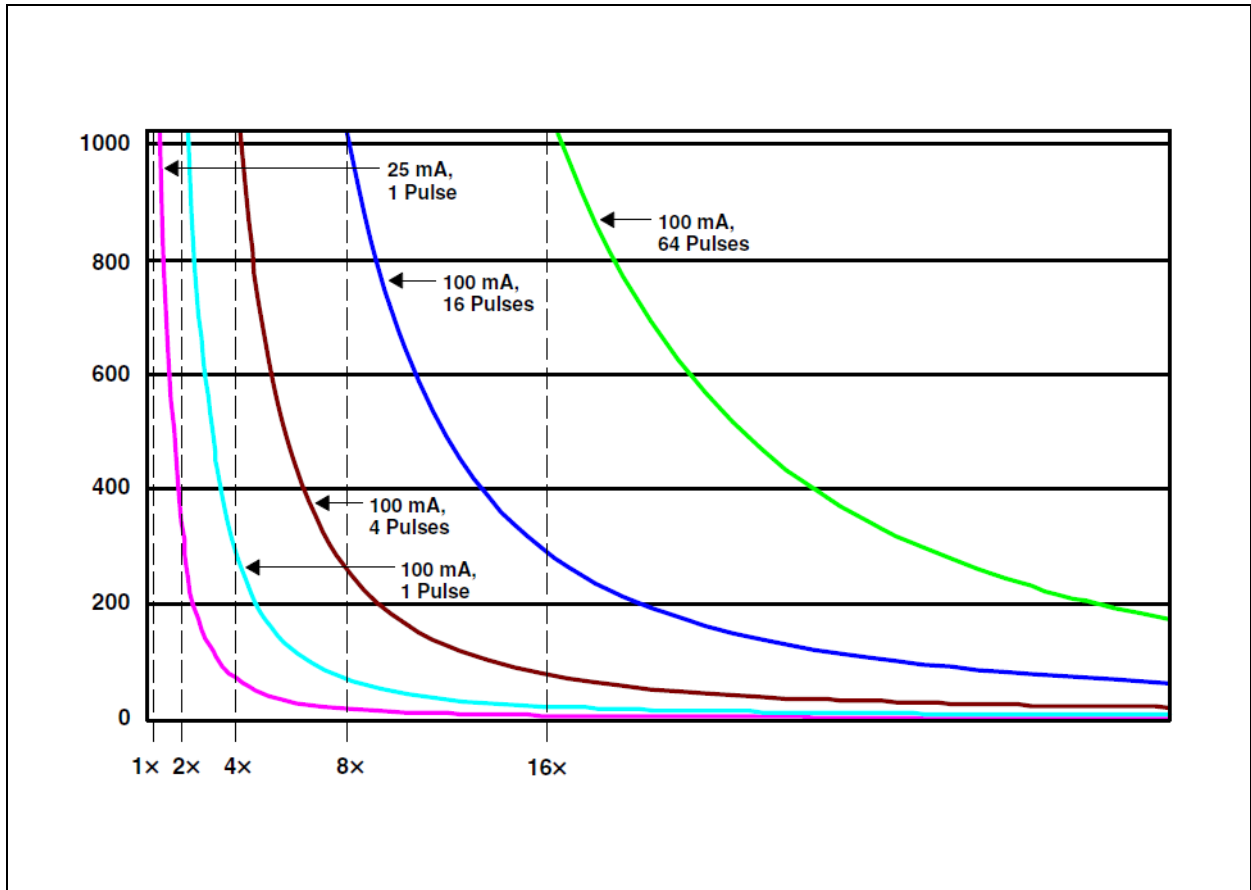

Interrupts

The interrupt feature simplifies and improves system efficiency by eliminating the need to poll the sensor for light intensity or proximity values outside of a user-defined range. While the interrupt function is always enabled and its status is available in the status register (0x13), the output of the interrupt state can be enabled using the proximity interrupt enable (PIEN) or RGBC interrupt enable (AIEN) fields in the Enable Register (0x00).

Four 16-bit interrupt threshold registers allow the user to set limits below and above a desired light level and proximity range. An interrupt can be generated when the RGBC Clear data (CDATA) falls outside of the desired light level range, as determined by the values in the RGBC interrupt low threshold registers (AILTx) and RGBC interrupt high threshold registers (AIHTx). Likewise, an out-of-range proximity interrupt can be generated when the proximity data (PDATA) falls below the

proximity interrupt low threshold (PILTx) or exceeds the proximity interrupt high threshold (PIHTx). It is important to note that the low threshold value must be less than the high threshold value for proper operation.

To further control when an interrupt occurs, the device provides a persistence filter. The persistence filter allows the user to specify the number of consecutive out-of-range RGBC or proximity occurrences before an interrupt is generated. The persistence register (0x0C) allows the user to set the RGBC persistence (APERS) and the proximity persistence (PPERS) values. See the persistence register for details on the persistence filter values. Once the persistence filter generates an interrupt, it will continue until a special function interrupt clear command is received (see [Command Register](#)).

Figure 25:
Programmable Interrupt

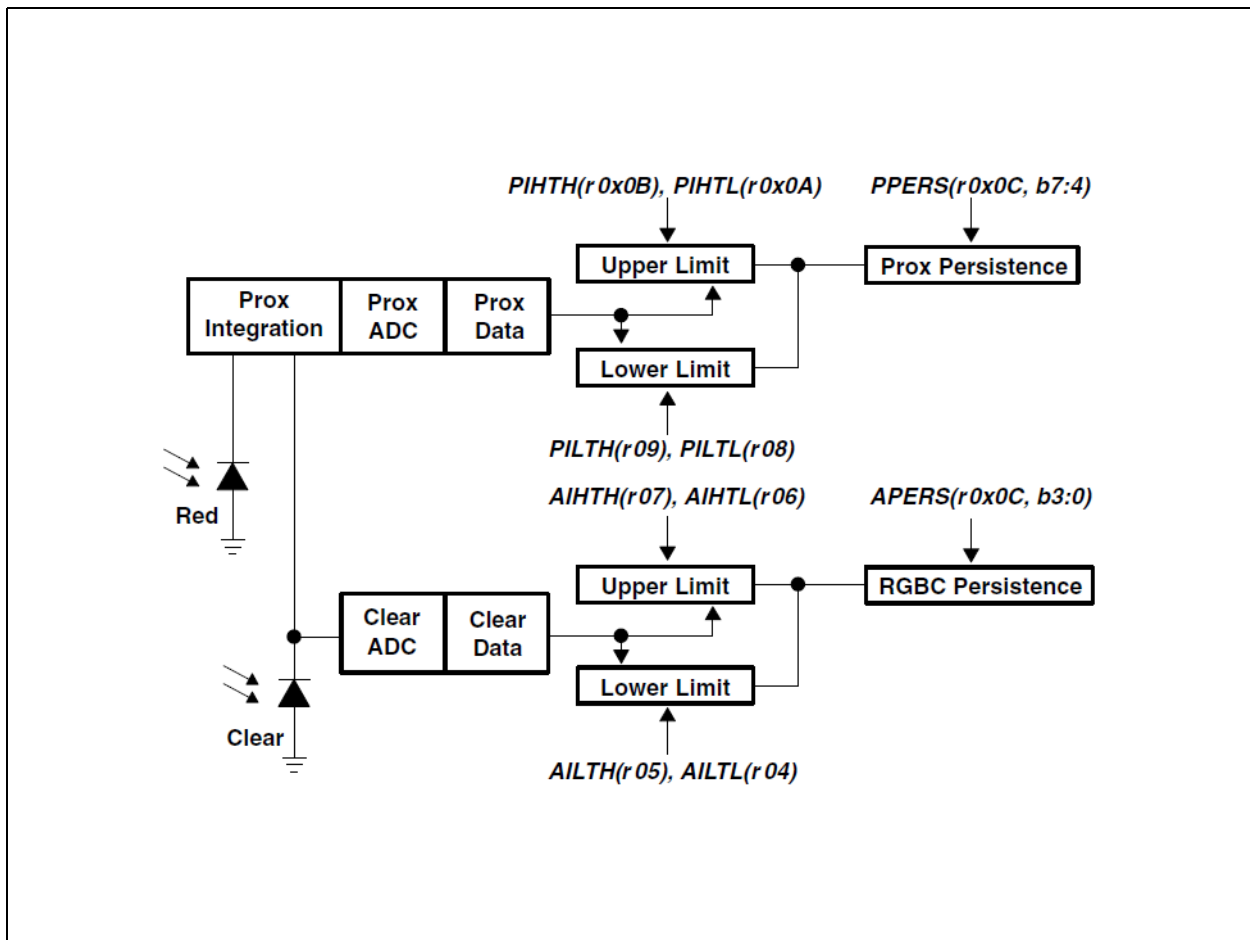

State Diagram

Figure 26 shows a more detailed flow for the state machine. The device starts in the sleep mode. The PON bit is written to enable the device. A 2.4ms delay will occur before entering the start state. If the PEN bit is set, the state machine will step through the proximity states of proximity accumulate and then proximity ADC conversion. As soon as the conversion is complete, the state machine will move to the following state.

If the WEN bit is set, the state machine will then cycle through the wait state. If the WLONG bit is set, the wait cycles are extended by 12x over normal operation. When the wait counter terminates, the state machine will step to the RGBC state.

The AEN should always be set, even in proximity-only operation. In this case, a minimum of 1 integration time step should be programmed. The RGBC state machine will continue until it reaches the terminal count at which point the data will be latched in the RGBC register and the interrupt set, if enabled.

Figure 26:
Expanded State Diagram

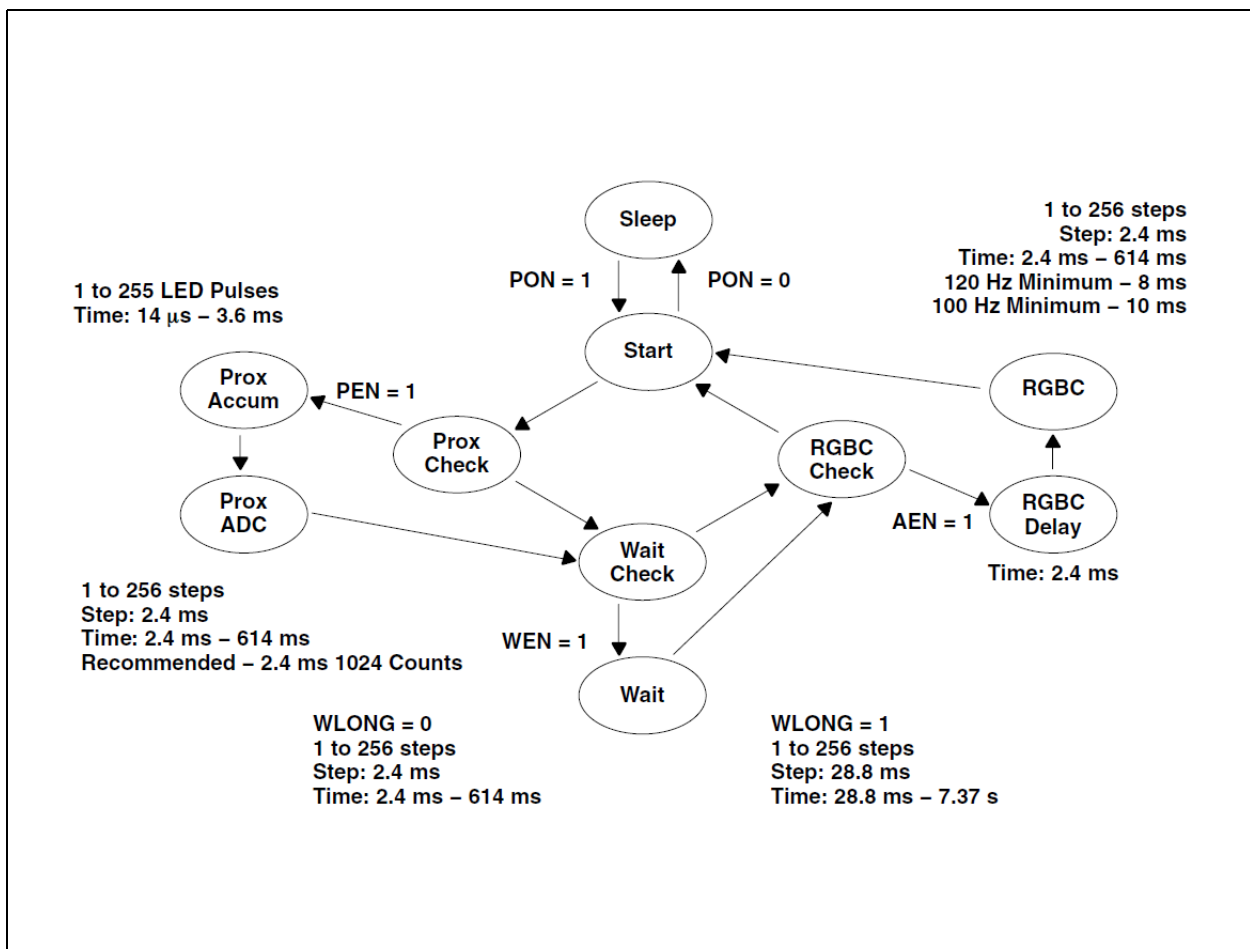

I²C Protocol

Interface and control are accomplished through an I²C serial compatible interface (standard or fast mode) to a set of registers that provide access to device control functions and output data. The devices support the 7-bit I²C addressing protocol.

The I²C standard provides for three types of bus transaction: read, write, and a combined protocol (Figure 27). During a write operation, the first byte written is a command byte followed by data. In a combined protocol, the first byte written is the command byte followed by reading a series of bytes. If a read command is issued, the register address from the previous command will be used for data access. Likewise, if the MSB of the command is not set, the device will write a series of bytes at the address stored in the last valid command with a register address. The command byte contains either control information or a 5-bit register address. The control commands can also be used to clear interrupts.

The I²C bus protocol was developed by Philips (now NXP). For a complete description of the I²C protocol, please review the NXP I²C design specification at <http://www.i2c-bus.org/references>.

Figure 27:
I²C Protocols

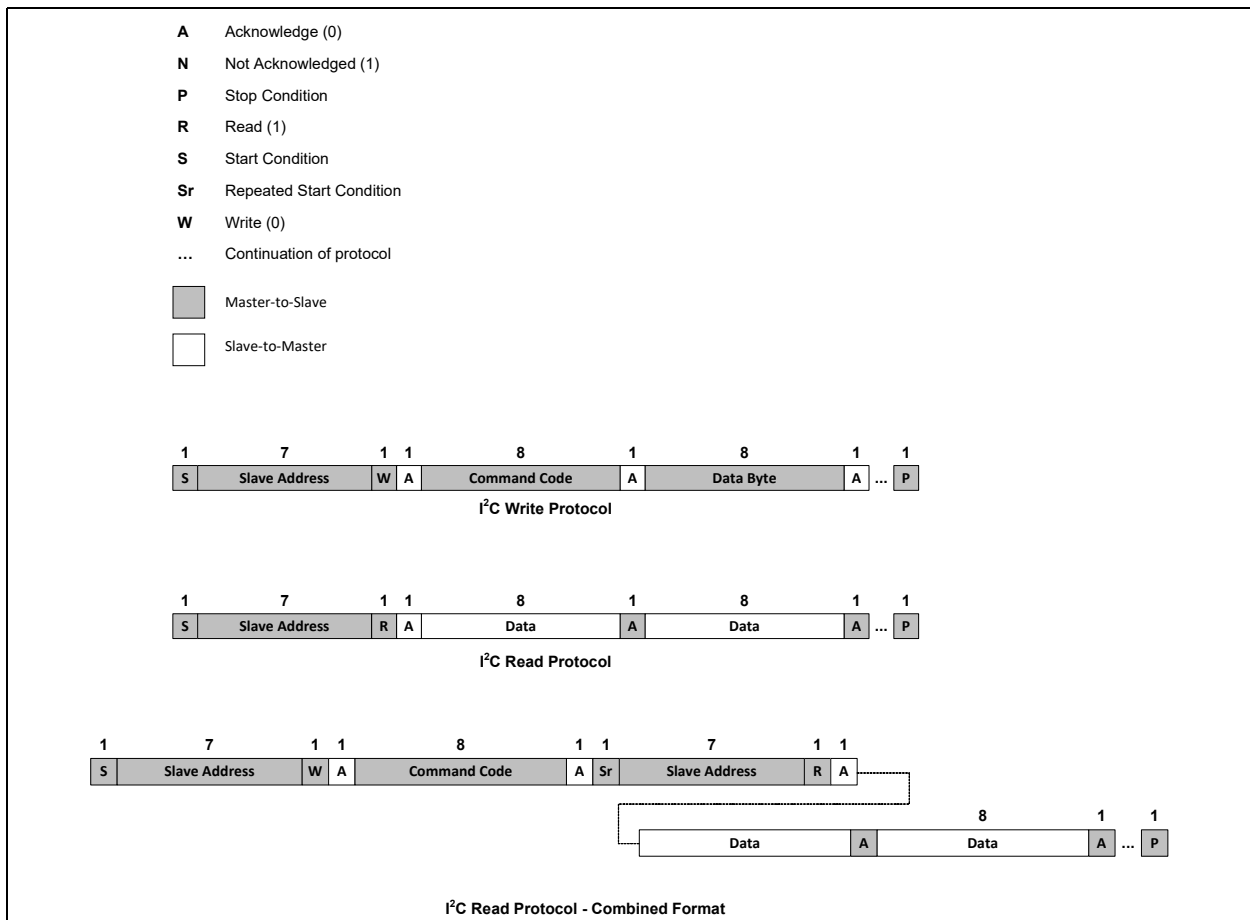

Register Set

The TCS3771 is controlled and monitored by data registers and a command register accessed through the serial interface. These registers provide for a variety of control functions and can be read to determine results of the ADC conversions. The Register Set is summarized in [Figure 28](#).

Figure 28:
Register Address

Address	Register Name	R/W	Register Function	Reset Value
--	COMMAND	W	Specifies register address	0x00
0x00	ENABLE	R/W	Enables states and interrupts	0x00
0x01	ATIME	R/W	RGBC ADC time	0xFF
0x02	PTIME	R/W	Proximity ADC time	0xFF
0x03	WTIME	R/W	Wait time	0xFF
0x04	AILTL	R/W	RGBC interrupt low threshold low byte	0x00
0x05	AILTH	R/W	RGBC interrupt low threshold high byte	0x00
0x06	AIHTL	R/W	RGBC interrupt high threshold low byte	0x00
0x07	AIHTH	R/W	RGBC interrupt high threshold high byte	0x00
0x08	PILTL	R/W	Proximity interrupt low threshold low byte	0x00
0x09	PILTH	R/W	Proximity interrupt low threshold high byte	0x00
0x0A	PIHTL	R/W	Proximity interrupt high threshold low byte	0x00
0x0B	PIHTH	R/W	Proximity interrupt high threshold high byte	0x00
0x0C	PERS	R/W	Interrupt persistence filters	0x00
0x0D	CONFIG	R/W	Configuration	0x00
0x0E	PPCOUNT	R/W	Proximity pulse count	0x00
0x0F	CONTROL	R/W	Gain control register	0x00
0x12	ID	R	Device ID	ID
0x13	STATUS	R	Device status	0x00
0x14	CDATA	R	Clear ADC low data register	0x00
0x15	CDATAH	R	Clear ADC high data register	0x00
0x16	RDATA	R	Red ADC low data register	0x00
0x17	RDATAH	R	Red ADC high data register	0x00
0x18	GDATA	R	Green ADC low data register	0x00

Address	Register Name	R/W	Register Function	Reset Value
0x19	GDATAH	R	Green ADC high data register	0x00
0x1A	BDATA	R	Blue ADC low data register	0x00
0x1B	BDATAH	R	Blue ADC high data register	0x00
0x1C	PDATA	R	Proximity ADC low data register	0x00
0x1D	PDATAH	R	Proximity ADC high data register	0x00

The mechanics of accessing a specific register depends on the specific protocol used (See [I2C Protocol](#)). In general, the Command register is written first to specify the specific control/status register for following read/write operations.

Command Register

The Command Registers specifies the address of the target register for future write and read operations.

Figure 29:
Command Register

	7	6	5	4	3	2	1	0
COMMAND	TYPE			ADD				

Field	Bits	Description	
COMMAND	7	Select Command Register. Must write as 1 when addressing Command Register.	
TYPE	6:5	Selects type of transaction to follow in subsequent data transfers:	
		Field Value	Integration Time
		00	Repeated byte protocol transaction
		01	Auto-increment protocol transaction
		10	Reserved - Do not use
		11	Special function - See description below
		Byte protocol will repeatedly read the same register with each data access. Block protocol will provide auto-increment function to read successive bytes.	
ADD	4:0	Address field/special function field. Depending on the transaction type, see above, this field either specifies a special function command or selects the specific control-status-register for following write and read transactions. The field values listed below apply only to special function commands:	
		Field Value	Read Value
		00000	Normal - no action
		00101	Proximity interrupt clear
		00110	RGBC interrupt clear
		00111	Proximity and RGBC interrupt clear
		other	Reserved — Do not write
		RGBC/Proximity Interrupt Clear. Clears any pending RGBC/Proximity interrupt. This special function is self clearing.	

Enable Register (0x00)

The Enable Register is used primarily to power the TCS3771 device on and off, and enable functions and interrupts as shown in [Figure 30](#).

Figure 30:
Enable Register

7	6	5	4	3	2	1	0
Reserved		PIEN	AIEN	WEN	PEN	AEN	PON

Field	Bits	Description
Reserved	7:6	Reserved. Write as 0.
PIEN	5	Proximity interrupt enable. When asserted, permits proximity interrupts to be generated.
AIEN	4	RGBC interrupt enable. When asserted, permits RGBC interrupts to be generated.
WEN	3	Wait enable. This bit activates the wait feature. Writing a 1 activates the wait timer. Writing a 0 disables the wait timer.
PEN	2	Proximity enable. This bit activates the proximity function. Writing a 1 enables proximity. Writing a 0 disables proximity.
AEN	1	RGBC enable. This bit activates the two-channel ADC. Writing a 1 activates the RGBC. Writing a 0 disables the RGBC.
PON ⁽¹⁾	0	Power ON. This bit activates the internal oscillator to permit the timers and ADC channels to operate. Writing a 1 activates the oscillator. Writing a 0 disables the oscillator. During reads and writes over the I ² C interface, this bit is temporarily overridden and the oscillator is enabled, independent of the state of PON.

Note(s):

1. A minimum interval of 2.4ms must pass after PON is asserted before either a proximity or an RGBC can be initiated. This required time is enforced by the hardware in cases where the firmware does not provide it.

RGBC Timing Register (0x01)

The RGBC Timing Register controls the internal integration time of the RGBC clear and IR channel ADCs in 2.4ms increments.

Figure 31:
RGBC Timing Register

Field	Bits	Description			
		Value	INTEG_CYCLES	Time	Max Count
ATIME	7:0	0xFF	1	2.4ms	1024
		0xF6	10	24ms	10240
		0xD6	42	101ms	43008
		0xAD	64	154ms	65535
		0x00	256	614ms	65535

Proximity Time Control Register (0x02)

The Proximity Timing Register controls the integration time of the proximity ADC in 2.4ms increments. It is recommended that this register be programmed to a value of 0xFF (1 cycle, 1023 bits).

Max Prox Count = $((256 - \text{PTIME}) \times 1024) - 1$ up to a maximum of 65535

Figure 32:
Proximity Time Control Register

Field	Bits	Description			
		Value	INTEG_CYCLES	Time	Max Count
PTIME	7:0	0xFF	1	2.4ms	1023

Wait Time Register (0x03)

Wait time is set 2.4ms increments unless the WLONG bit is asserted in which case the wait times are 12× longer. WTIME is programmed as a 2's complement number.

Figure 33:
Wait Time Register

Field	Bits	Description			
WTIME	7:0	Register Value	Wait Time	Time (WLONG = 0)	Time (WLONG = 1)
		0xFF	1	2.4ms	0.029 sec
		0xAB	85	204ms	2.45 sec
		0x00	256	614ms	7.4 sec

RGBC Interrupt Threshold Registers (0x04 – 0x07)

The RGBC Interrupt Threshold Registers provides the values to be used as the high and low trigger points for the comparison function for interrupt generation. If the value generated by the clear channel crosses below the lower threshold specified, or above the higher threshold, an interrupt is asserted on the interrupt pin.

Figure 34:
RGBC Interrupt Threshold Registers

Register	Address	Bits	Description
AILTL	0x04	7:0	RGBC clear channel low threshold lower byte
AILTH	0x05	7:0	RGBC clear channel low threshold upper byte
AIHTL	0x06	7:0	RGBC clear channel high threshold lower byte
AIHTH	0x07	7:0	RGBC clear channel high threshold upper byte

Proximity Interrupt Threshold Registers (0x08 – 0x0B)

The Proximity Interrupt Threshold Registers provide the values to be used as the high and low trigger points for the comparison function for interrupt generation. If the value generated by proximity channel crosses below the lower threshold specified, or above the higher threshold, an interrupt is signaled to the host processor.

Figure 35:
Proximity Interrupt Threshold Register

Register	Address	Bits	Description
PILTL	0x08	7:0	Proximity ADC channel low threshold lower byte
PILTH	0x09	7:0	Proximity ADC channel low threshold upper byte
PIHTL	0x0A	7:0	Proximity ADC channel high threshold lower byte
PIHTH	0x0B	7:0	Proximity ADC channel high threshold upper byte

Persistence Register (0x0C)

The Persistence Register controls the filtering interrupt capabilities of the device. Configurable filtering is provided to allow interrupts to be generated after each integration cycle or if the integration has produced a result that is outside of the values specified by the threshold register for some specified amount of time. Separate filtering is provided for proximity and the RGBC clear channel.

Figure 36:
Persistence Register

	7	6	5	4	3	2	1	0
PPERS					APERS			

Field	Bits	Description		
PPERS	7:4	Proximity interrupt persistence. Controls rate of proximity interrupt to the host processor.		
		Field Value	Meaning	Interrupt Persistence Function
		0000	----	Every proximity cycle generates an interrupt
		0001	1	1 proximity value out of range
		0010	2	2 consecutive proximity values out of range
	
		1111	15	15 consecutive proximity values out of range

Field	Bits	Description		
APERS	3:0	Interrupt persistence. Controls rate of interrupt to the host processor.		
		Field Value	Meaning	Interrupt Persistence Function
		0000	Every	Every RGBC cycle generates an interrupt
		0001	1	1 clear channel value outside of threshold range
		0010	2	2 clear channel consecutive values out of range
		0011	3	3 clear channel consecutive values out of range
		0100	5	5 clear channel consecutive values out of range
		0101	10	10 clear channel consecutive values out of range
		0110	15	15 clear channel consecutive values out of range
		0111	20	20 clear channel consecutive values out of range
		1000	25	25 clear channel consecutive values out of range
		1001	30	30 clear channel consecutive values out of range
		1010	35	35 clear channel consecutive values out of range
		1011	40	40 clear channel consecutive values out of range
		1100	45	45 clear channel consecutive values out of range
		1101	50	50 clear channel consecutive values out of range
		1110	55	55 clear channel consecutive values out of range
1111	60	60 clear channel consecutive values out of range		

Configuration Register (0x0D)

The Configuration Register sets the wait long time.

Figure 37:
Configuration Register

	7	6	5	4	3	2	1	0
Reserved							WLONG	Reserved

Field	Bits	Description
Reserved	7:2	Reserved. Write as 0.
WLONG	1	Wait Long. When asserted, the wait cycles are increased by a factor 12× from that programmed in the WTIME register.
Reserved	0	Reserved. Write as 0.

Proximity Pulse Count Register (0x0E)

The Proximity Pulse Count Register sets the number of proximity pulses that will be transmitted. When proximity detection is enabled, a proximity detect cycle occurs after each RGBC cycle. PPULSE defines the number of pulses to be transmitted.

Note(s): The ATIME register will be used to time the interval between proximity detection events even if the RGBC function is disabled.

Figure 38:
Proximity Pulse Count Register

	7	6	5	4	3	2	1	0
PPULSE								

Field	Bits	Description
PPULSE	7:0	Proximity Pulse Count. Specifies the number of proximity pulses to be generated.

Control Register (0x0F)

The Control Register provides eight bits of miscellaneous control to the analog block. These bits typically control functions such as gain settings and/or diode selection.

Figure 39:
Control Register

7	6	5	4	3	2	1	0
PDRIVE		PDIODE		Reserved		AGAIN	

Field	Bits	Description	
PDRIVE	7:6	LED Drive Strength.	
		Field Value	LED Strength
		00	100mA
		01	50mA
		10	25mA
		11	12.5mA
PDIODE	5:4	Proximity Diode Select.	
		Field Value	Diode Selection
		00	Reserved
		01	Proximity uses the clear (broadband) diode
		10	Proximity uses the IR diode
		11	Proximity uses both the clear diode and the red diode
Reserved	3:2	Reserved. Write bits as 0.	
AGAIN	1:0	RGBC Gain Control.	
		Field Value	RGBC Gain Value
		00	1× gain
		01	4× gain
		10	16× gain
		11	60× gain

ID Register (0x12)

The ID Register provides the value for the part number. The ID Register is a read-only register.

Figure 40:
ID Register

7	6	5	4	3	2	1	0
ID							

Field	Bits	Description	
ID	7:0	Part number identification	0x10 = TCS37715
			0x19 = TCS37717

Status Register (0x13)

The Status Register provides the internal status of the device. This register is read only.

Figure 41:
Status Register

7	6	5	4	3	2	1	0
Reserved		PINT	AINT	Reserved		PVALID	AVALID

Field	Bits	Description
Reserved	7:6	Reserved
PINT	5	Proximity Interrupt
AINT	4	RGBC clear channel Interrupt
Reserved	3:2	Reserved
PVALID	1	Proximity Valid. Indicates that a RGBC cycle has completed since AEN was asserted.
AVALID	0	RGBC Valid. Indicates that the RGBC channels have completed an integration cycle.

RGBC Channel Data Registers (0x14 – 0x1B)

Clear, red, green, and blue data is stored as 16-bit values. To ensure the data is read correctly, a two-byte read I²C transaction should be used with a read word protocol bit set in the Command Register. With this operation, when the lower byte register is read, the upper eight bits are stored into a shadow register, which is read by a subsequent read to the upper byte. The upper register will read the correct value even if additional ADC integration cycles end between the reading of the lower and upper registers.

Figure 42:
ADC Channel Data Registers

Register	Address	Bits	Description
CDATA	0x14	7:0	Clear data low byte
CDATAH	0x15	7:0	Clear data high byte
RDATA	0x16	7:0	Red data low byte
RDATAH	0x17	7:0	Red data high byte
GDATA	0x18	7:0	Green data low byte
GDATAH	0x19	7:0	Green data high byte
BDATA	0x1A	7:0	Blue data low byte
BDATAH	0x1B	7:0	Blue data high byte

Proximity Data Registers (0x1C – 0x1D)

Proximity data is stored as a 16-bit value. To ensure the data is read correctly, a two-byte read I²C transaction should be used with a read word protocol bit set in the Command Register. With this operation, when the lower byte register is read, the upper eight bits are stored into a shadow register, which is read by a subsequent read to the upper byte. The upper register will read the correct value even if additional ADC integration cycles end between the reading of the lower and upper registers.

Figure 43:
PDATA Registers

Register	Address	Bits	Description
PDATA	0x1C	7:0	Proximity data low byte
PDATAH	0x1D	7:0	Proximity data high byte

Application Information

LED Driver Pin with Proximity Detection

In a proximity sensing system, the IR LED can be pulsed by the TCS3771 with more than 100mA of rapidly switching current, therefore, a few design considerations must be kept in mind to get the best performance. The key goal is to reduce the power supply noise coupled back into the device during the LED pulses.

The first recommendation is to use two power supplies; one for the device V_{DD} and the other for the IR LED. In many systems, there is a quiet analog supply and a noisy digital supply. By connecting the quiet supply to the V_{DD} pin and the noisy supply to the LED, the key goal can be met. Place a $1\mu\text{F}$ low-ESR decoupling capacitor as close as possible to the V_{DD} pin and another at the LED anode, and a $22\mu\text{F}$ capacitor at the output of the LED voltage regulator to supply the 100mA current surge.

Figure 44:
Proximity Sensing Using Separate Power Supplies

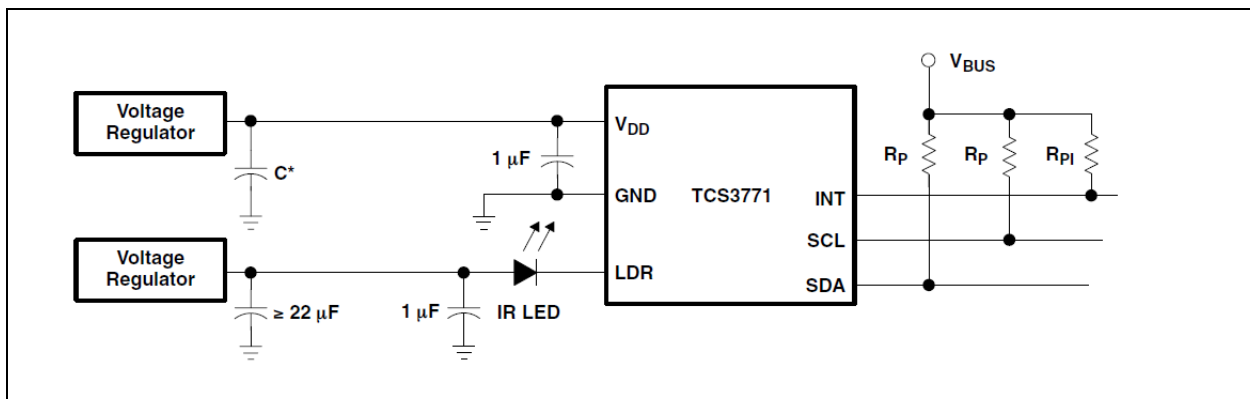

If it is not possible to provide two separate power supplies, the device can be operated from a single supply. A 22Ω resistor in series with the V_{DD} supply line and a $1\mu\text{F}$ low ESR capacitor effectively filter any power supply noise. The previous capacitor placement considerations apply.

Figure 45:
Proximity Sensing Using Single Power Supply

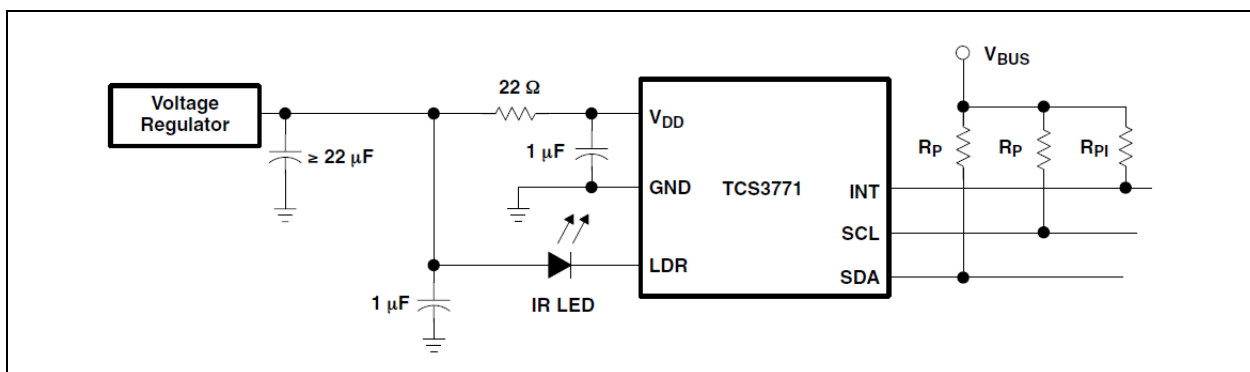

V_{BUS} in the above figures refers to the I²C bus voltage which is either V_{DD} or 1.8V. Be sure to apply the specified I²C bus voltage shown in the Available Options table for the specific device being used.

The I²C signals and the Interrupt are open-drain outputs and require pull-up resistors. The pull-up resistor (RP) value is a function of the I²C bus speed, the I²C bus voltage, and the capacitive load. The ams EVM running at 400kbps, uses 1.5k Ω resistors. A 10k Ω pull-up resistor (RPI) can be used for the interrupt line.

PCB Pad Layout

Suggested PCB pad layout guidelines for the Dual Flat No-Lead (FN) surface mount package are shown in [Figure 46](#).

Figure 46:
Suggested FN Package PCB Layout

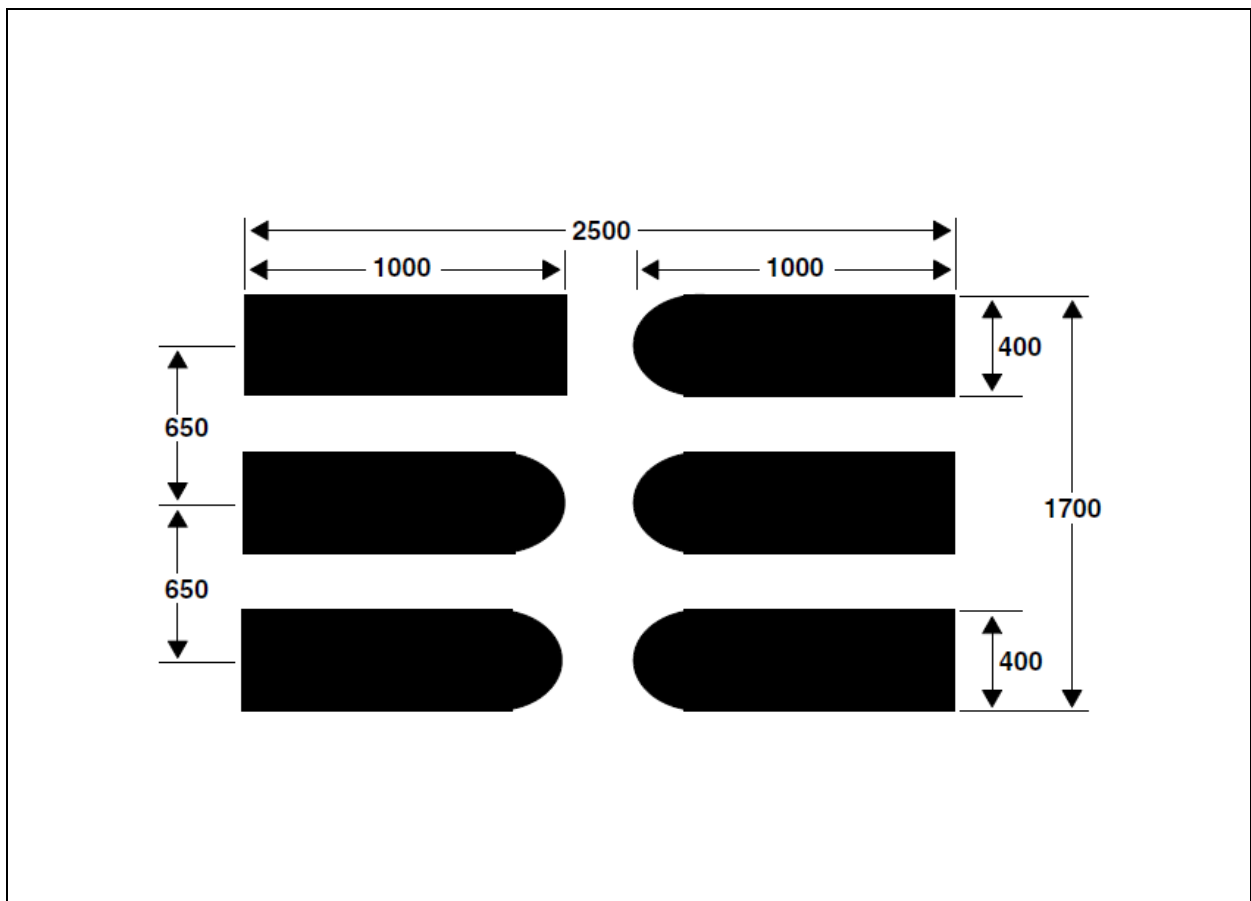

Note(s):

1. All linear dimensions are in millimeters.
2. This drawing is subject to change without notice.
3. Pads can be extended further if hand soldering is needed.

Packaging Mechanical Data

Figure 47:
Package FN - Dual Flat No-Lead Packaging Configuration

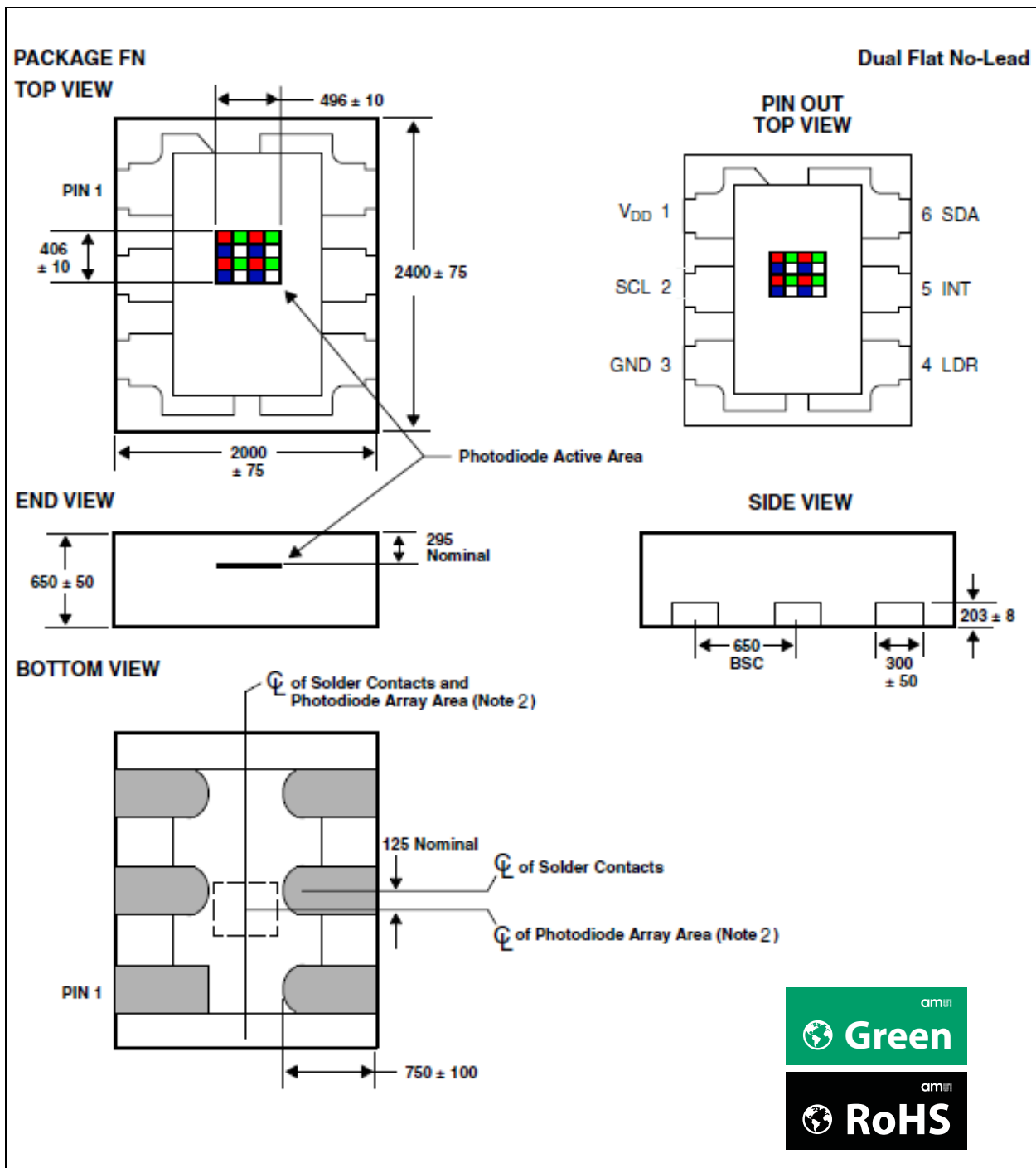

Note(s):

1. All linear dimensions are in micrometers.
2. The die is centered within the package within a tolerance of $\pm 75\mu\text{m}$.
3. Package top surface is molded with an electrically nonconductive clear plastic compound having an index of refraction of 1.55.
4. Contact finish is copper alloy A194 with pre-plated NiPdAu lead finish.
5. This package contains no lead (Pb).
6. This drawing is subject to change without notice.

Figure 48:
Package FN Carrier Tape

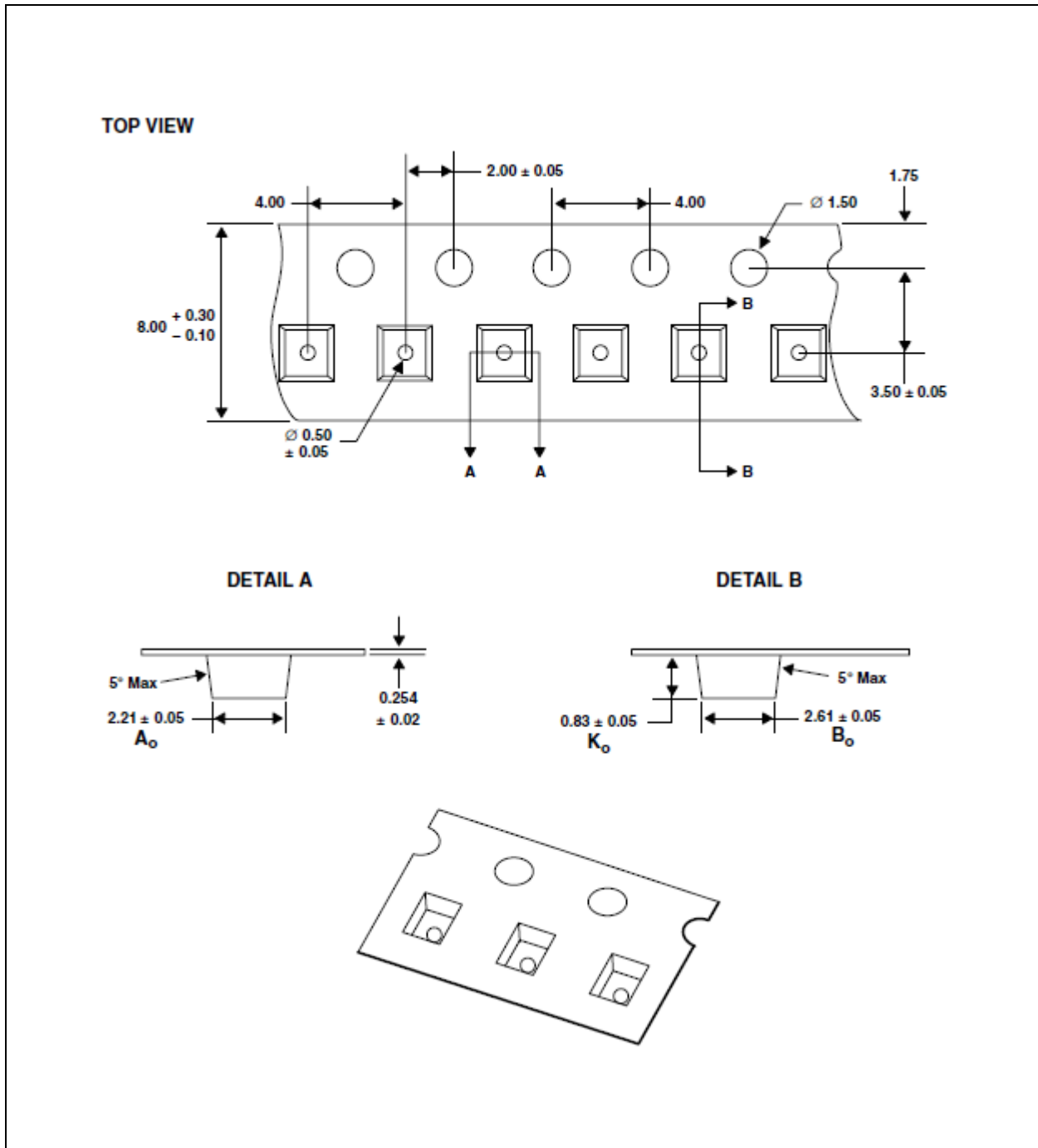

Note(s):

1. All linear dimensions are in millimeters. Dimension tolerance is ± 0.10 mm unless otherwise noted.
2. The dimensions on this drawing are for illustrative purposes only. Dimensions of an actual carrier may vary slightly.
3. Symbols on drawing A_o , B_o , and K_o are defined in ANSI EIA Standard 481-B 2001.
4. Each reel is 178 millimeters in diameter and contains 3500 parts.
5. ams AG packaging tape and reel conform to the requirements of EIA Standard 481-B.
6. In accordance with EIA standard, device pin 1 is located next to the sprocket holes in the tape.
7. This drawing is subject to change without notice.

Manufacturing Information

The FN package has been tested and has demonstrated an ability to be reflow soldered to a PCB substrate.

The solder reflow profile describes the expected maximum heat exposure of components during the solder reflow process of product on a PCB. Temperature is measured on top of component. The components should be limited to a maximum of three passes through this solder reflow profile.

Figure 49:
TCS3771 Solder Reflow Profile

Parameter	Reference	TCS3771
Average temperature gradient in preheating		2.5°C/sec
Soak time	t_{soak}	2 to 3 minutes
Time above 217°C (T1)	t_1	Max 60 sec
Time above 230°C (T2)	t_2	Max 50 sec
Time above $T_{peak} - 10^\circ\text{C}$ (T3)	t_3	Max 10 sec
Peak temperature in reflow	T_{peak}	260° C
Temperature gradient in cooling		Max -5°C/sec

Figure 50:
Solder Reflow Profile Graph

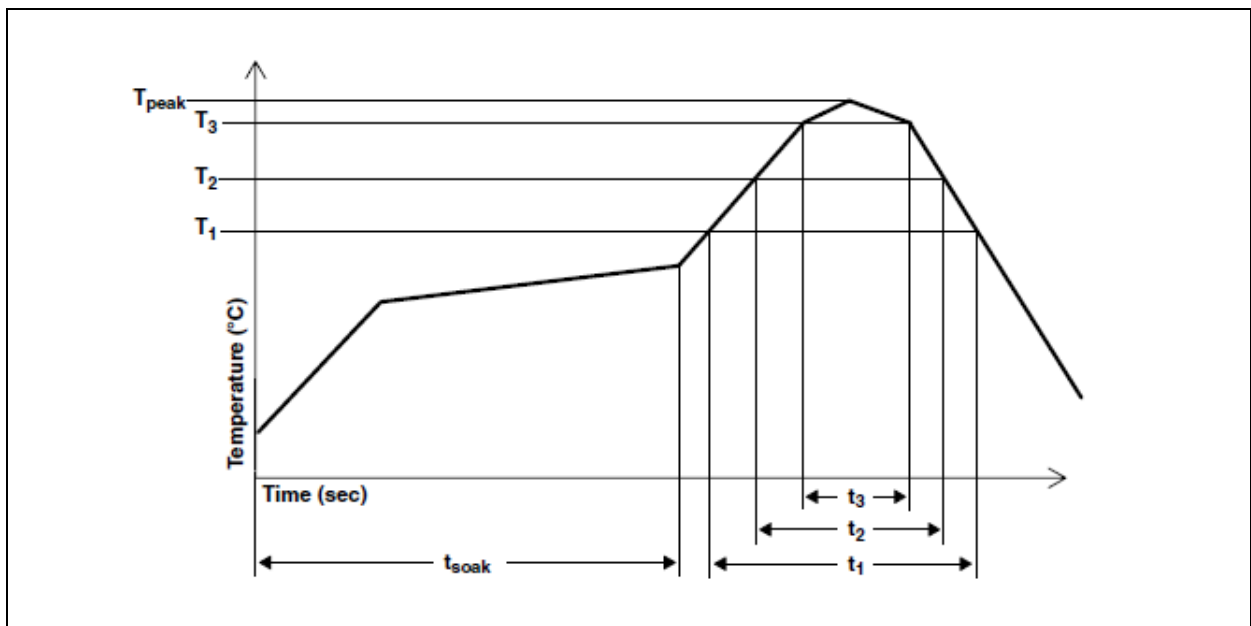

Note(s):

1. Not to scale - for reference only.

Moisture Sensitivity

Optical characteristics of the device can be adversely affected during the soldering process by the release and vaporization of moisture that has been previously absorbed into the package. To ensure the package contains the smallest amount of absorbed moisture possible, each device is dry-baked prior to being packed for shipping. Devices are packed in a sealed aluminized envelope called a moisture barrier bag with silica gel to protect them from ambient moisture during shipping, handling, and storage before use.

The FN package has been assigned a moisture sensitivity level of MSL 3 and the devices should be stored under the following conditions:

- Temperature Range: 5°C to 50°C
- Relative Humidity: 60% maximum
- Total Time: 12 months from the date code on the aluminized envelope - if unopened
- Opened Time: 168 hours or fewer

Rebaking will be required if the devices have been stored unopened for more than 12 months or if the aluminized envelope has been open for more than 168 hours. If rebaking is required, it should be done at 50°C for 12 hours.

Ordering & Contact Information

Figure 51:
Ordering Information

Ordering Code	Device	Address	Package - Leads	Interface Description
TCS37715FN	TCS37715	0x29	FN-6	I ² C Vbus = V _{DD} Interface
TCS37717FN	TCS37717	0x29	FN-6	I ² C Vbus = 1.8V Interface

Buy our products or get free samples online at:

www.ams.com/ICdirect

Technical Support is available at:

www.ams.com/Technical-Support

Provide feedback about this document at:

www.ams.com/Document-Feedback

For further information and requests, e-mail us at:

ams_sales@ams.com

For sales offices, distributors and representatives, please visit:

www.ams.com/contact

Headquarters

ams AG
Tobelbader Strasse 30
8141 Premstaetten
Austria, Europe

Tel: +43 (0) 3136 500 0

Website: www.ams.com

RoHS Compliant & ams Green Statement

RoHS: The term RoHS compliant means that ams AG products fully comply with current RoHS directives. Our semiconductor products do not contain any chemicals for all 6 substance categories, including the requirement that lead not exceed 0.1% by weight in homogeneous materials. Where designed to be soldered at high temperatures, RoHS compliant products are suitable for use in specified lead-free processes.

ams Green (RoHS compliant and no Sb/Br): ams Green defines that in addition to RoHS compliance, our products are free of Bromine (Br) and Antimony (Sb) based flame retardants (Br or Sb do not exceed 0.1% by weight in homogeneous material).

Important Information: The information provided in this statement represents ams AG knowledge and belief as of the date that it is provided. ams AG bases its knowledge and belief on information provided by third parties, and makes no representation or warranty as to the accuracy of such information. Efforts are underway to better integrate information from third parties. ams AG has taken and continues to take reasonable steps to provide representative and accurate information but may not have conducted destructive testing or chemical analysis on incoming materials and chemicals. ams AG and ams AG suppliers consider certain information to be proprietary, and thus CAS numbers and other limited information may not be available for release.

Copyrights & Disclaimer

Copyright ams AG, Tobelbader Strasse 30, 8141 Premstaetten, Austria-Europe. Trademarks Registered. All rights reserved. The material herein may not be reproduced, adapted, merged, translated, stored, or used without the prior written consent of the copyright owner.

Devices sold by ams AG are covered by the warranty and patent indemnification provisions appearing in its General Terms of Trade. ams AG makes no warranty, express, statutory, implied, or by description regarding the information set forth herein. ams AG reserves the right to change specifications and prices at any time and without notice. Therefore, prior to designing this product into a system, it is necessary to check with ams AG for current information. This product is intended for use in commercial applications. Applications requiring extended temperature range, unusual environmental requirements, or high reliability applications, such as military, medical life-support or life-sustaining equipment are specifically not recommended without additional processing by ams AG for each application. This product is provided by ams AG "AS IS" and any express or implied warranties, including, but not limited to the implied warranties of merchantability and fitness for a particular purpose are disclaimed.

ams AG shall not be liable to recipient or any third party for any damages, including but not limited to personal injury, property damage, loss of profits, loss of use, interruption of business or indirect, special, incidental or consequential damages, of any kind, in connection with or arising out of the furnishing, performance or use of the technical data herein. No obligation or liability to recipient or any third party shall arise or flow out of ams AG rendering of technical or other services.

Document Status

Document Status	Product Status	Definition
Product Preview	Pre-Development	Information in this datasheet is based on product ideas in the planning phase of development. All specifications are design goals without any warranty and are subject to change without notice
Preliminary Datasheet	Pre-Production	Information in this datasheet is based on products in the design, validation or qualification phase of development. The performance and parameters shown in this document are preliminary without any warranty and are subject to change without notice
Datasheet	Production	Information in this datasheet is based on products in ramp-up to full production or full production which conform to specifications in accordance with the terms of ams AG standard warranty as given in the General Terms of Trade
Datasheet (discontinued)	Discontinued	Information in this datasheet is based on products which conform to specifications in accordance with the terms of ams AG standard warranty as given in the General Terms of Trade, but these products have been superseded and should not be used for new designs

Revision Information

Changes from 1-30 (2014-Sep-01) to current revision 1-31 (2018-Apr-04)	Page
Updated Figure 7	7
Updated Figure 40	35
Updated Figure 51	43

Note(s):

1. Page and figure numbers for the previous version may differ from page and figure numbers in the current revision.
2. Correction of typographical errors is not explicitly mentioned.

Content Guide

1	General Description
2	Key Benefits & Features
2	Applications
3	End Products and Market Segments
3	Block Diagram
4	Detailed Description
5	Pin Assignments
6	Absolute Maximum Ratings
7	Electrical Characteristics
12	Parameter Measurement Information
13	Typical Characteristics
16	Principles of Operation
16	System State Machine
17	RGBC Operation
18	Proximity Detection
20	Interrupts
22	State Diagram
23	I2C Protocol
24	Register Set
26	Command Register
27	Enable Register (0x00)
28	RGBC Timing Register (0x01)
28	Proximity Time Control Register (0x02)
29	Wait Time Register (0x03)
29	RGBC Interrupt Threshold Registers (0x04 – 0x07)
30	Proximity Interrupt Threshold Registers (0x08 – 0x0B)
31	Persistence Register (0x0C)
33	Configuration Register (0x0D)
33	Proximity Pulse Count Register (0x0E)
34	Control Register (0x0F)
35	ID Register (0x12)
35	Status Register (0x13)
36	RGBC Channel Data Registers (0x14 – 0x1B)
36	Proximity Data Registers (0x1C – 0x1D)
37	Application Information
37	LED Driver Pin with Proximity Detection
38	PCB Pad Layout
39	Packaging Mechanical Data
41	Manufacturing Information
42	Moisture Sensitivity
43	Ordering & Contact Information
44	RoHS Compliant & ams Green Statement
45	Copyrights & Disclaimer
46	Document Status
47	Revision Information

Looking for pricing, stock, or lifecycle information?

Click below to explore more details on WIN SOURCE:

- ⊖ [View TCS37715FN](#) on WIN SOURCE
- ⊖ [ams](#) Information

Optimize Your Supply Chain with WIN SOURCE Solutions

- ✓ Global Sourcing Solution
- ✓ Obsolete Management
- ✓ Cost Control Management
- ✓ Shortage Management
- ✓ Alternative Solution
- ✓ Excess Inventory Management