



# THE DATASHEET OF TLE2301INE



# TLE2301 EXCALIBUR 3-STATE-OUTPUT WIDE-BANDWIDTH POWER OPERATIONAL AMPLIFIER

SLOS131 – DECEMBER 1993

- High Output Drive Capability . . . 1 A Min
- 3-State Outputs
- High Gain-Bandwidth Product  
8 MHz Typ
- Low Total Harmonic Distortion  
<0.08% Typ
- High Slew Rate . . . 12 V/ $\mu$ s Typ
- Class AB Output Stage
- Thermal Shutdown
- Mains-Line Driver Circuit Application  
Included

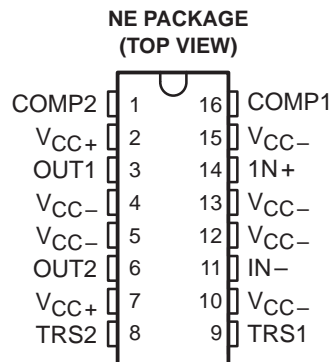

Terminals 4, 5, 12 and 13 are connected to the lead frame.

## description

The TLE2301 is a power operational amplifier that can deliver an output current of 1 A at high frequencies with very low total harmonic distortion. The device has an integral 3-state mode to drive the output stage into a high-impedance state and also to reduce the supply current to less than 3.5 mA.

The combination of high output current and 3-state outputs makes the TLE2301 ideal for implementing the signalling transformer driver in mains-based telemetering modems. This combination of features also makes the device well suited for other high-current applications (e.g., motor drivers and audio circuits).

Using the Texas Instruments established Excalibur process, the TLE2301 is able to achieve slew rates in excess of 12 V/ $\mu$ s and a gain-bandwidth product of 8 MHz. The TLE2301 uses a 16-pin NE power package to provide better power handling capabilities than standard dual-in-line packages.

The TLE2301 is characterized for operation over the industrial temperature range of  $-40^{\circ}\text{C}$  to  $85^{\circ}\text{C}$ .

## MAXIMUM PEAK-TO-PEAK OUTPUT VOLTAGE vs FREQUENCY

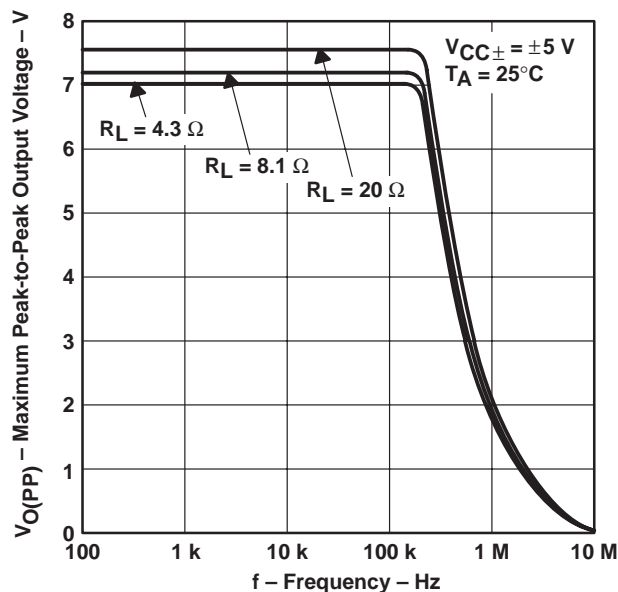

Figure 1

### AVAILABLE OPTION

$T_A$	$V_{IOmax}$ AT $25^{\circ}\text{C}$	PACKAGE
		THERMALLY-ENHANCED PLASTIC DIP (NE)
$-40^{\circ}\text{C}$ to $85^{\circ}\text{C}$	10 mV	TLE2301NE

PRODUCTION DATA information is current as of publication date. Products conform to specifications per the terms of Texas Instruments standard warranty. Production processing does not necessarily include testing of all parameters.



POST OFFICE BOX 655303 • DALLAS, TEXAS 75265

Copyright © 1993, Texas Instruments Incorporated

# TLE2301 EXCALIBUR 3-STATE-OUTPUT WIDE-BANDWIDTH POWER OPERATIONAL AMPLIFIER

SLOS131 – DECEMBER 1993

## equivalent schematic (entire device)

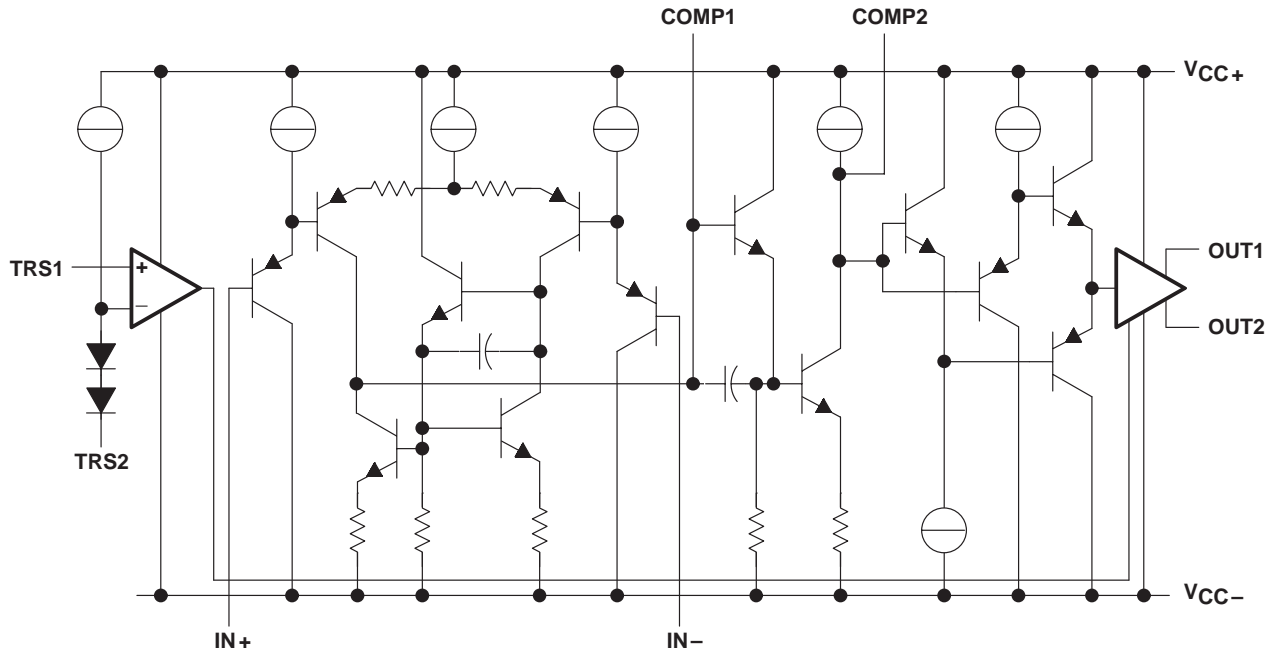

## equivalent schematic (TRS1 and TRS2 inputs)

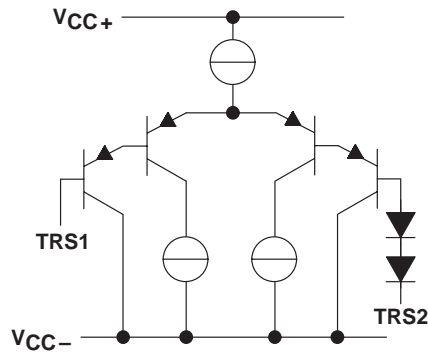

**TLE2301**  
**EXCALIBUR 3-STATE-OUTPUT WIDE-BANDWIDTH**  
**POWER OPERATIONAL AMPLIFIER**

SLOS131 – DECEMBER 1993

**Terminal Functions**

TERMINAL NAME NO.	DESCRIPTION
COMP1 16 COMP2 1	COMP1 and COMP2 are compensation network terminals
IN+ 14	Noninverting input
IN– 11	Inverting input
OUT1 3 OUT2 6	Two low-distortion class-AB output stages. Each is capable of sourcing more than 500 mA. OUT1 and OUT2 should be connected together for all applications.
TRS1 9 TRS2 8	TRS1 and TRS2 are 3-state input terminals. TRS2 should be connected to the ground of the circuit generating the 3-state command (normally $\mu\text{P}$ ground). The TLE2301 is brought into 3-state mode by raising TRS1 2 V above TRS2. Placing the TLE2301 in a 3-state mode reduces the supply current to below 2.2 mA (typ). Normal operation resumes by bringing TRS1 to within 0.8 V of TRS2. The 3-state function can be disabled by connecting both TRS1 and TRS2 to $V_{CC-}$ .
$V_{CC-}$ 10, 15	High-impedance $V_{CC-}$ input terminals. Although these do not carry any of the device's supply current, they increase the stability of the device and should be connected to the negative supply terminal ( $V_{CC-}$ ).
$V_{CC-}$ 4, 5, 12, 13	Negative supply terminals and substrate. As with all NE packages, the substrate is directly connected to the lead frame. The result is that the junction-to-ambient thermal impedance ( $Z_{\theta JA}$ ) is greatly reduced by soldering the negative supply terminals to the copper area of the printed-circuit board (PCB).
$V_{CC+}$ 2, 7	Positive supply terminals. Both terminals should be connected to the positive voltage supply.



**TLE2301**  
**EXCALIBUR 3-STATE-OUTPUT WIDE-BANDWIDTH**  
**POWER OPERATIONAL AMPLIFIER**

SLOS131 – DECEMBER 1993

**absolute maximum ratings over operating free-air temperature range (unless otherwise noted)†**

Supply voltage, $V_{CC+}$ (see Note 1)	22 V
Supply voltage, $V_{CC-}$ (see Note 1)	-22 V
Differential input voltage, $V_{ID}$ (see Note 2)	$\pm 44$ V
Duration of short-circuit current at (or below) 25°C (see Note 3)	unlimited
Continuous total dissipation at (or below) 25°C free-air temperature (see Notes 4 and 5)	2075 mW
Continuous total dissipation at 85°C case temperature (see Note 5)	4640 mW
Operating free-air temperature range, $T_A$	-40°C to 85°C
Operating case or virtual junction temperature range	-40°C to 150°C
Storage temperature range	-65°C to 150°C

† Stresses beyond those listed under “absolute maximum ratings” may cause permanent damage to the device. These are stress ratings only, and functional operation of the device at these or any other conditions beyond those indicated under “recommended operating conditions” is not implied. Exposure to absolute-maximum-rated conditions for extended periods may affect device reliability.

- NOTES:
1. All voltage values, except differential voltages, are with respect to the midpoint between  $V_{CC+}$  and  $V_{CC-}$ .
  2. Differential voltages are at  $IN+$  with respect to  $IN-$ .
  3. The outputs when connected together may be shorted to either supply. Temperature and/or supply voltages must be limited to ensure that the maximum dissipation rating is not exceeded.
  4. For operation above 25°C free-air temperature, derate linearly at the rate of 16.56 mW/°C.
  5. For operation above 25°C case temperature, derate linearly at the rate of 71.4 mW/°C. To avoid exceeding the design maximum virtual junction temperature, these ratings should not be exceeded. Due to variations in individual device electrical characteristics and thermal resistance, the built-in thermal overload protection may be activated at power levels slightly above or below the rated dissipation.

**FREE-AIR TEMPERATURE  
DISSIPATION DERATING CURVE**

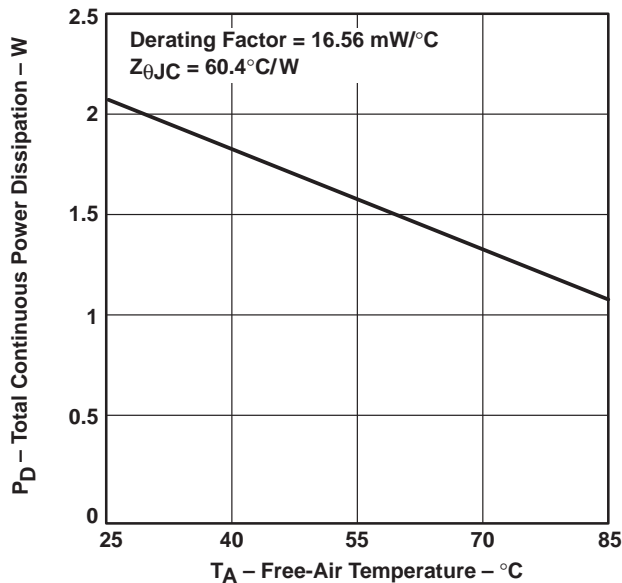

**CASE TEMPERATURE  
DISSIPATION DERATING CURVE**

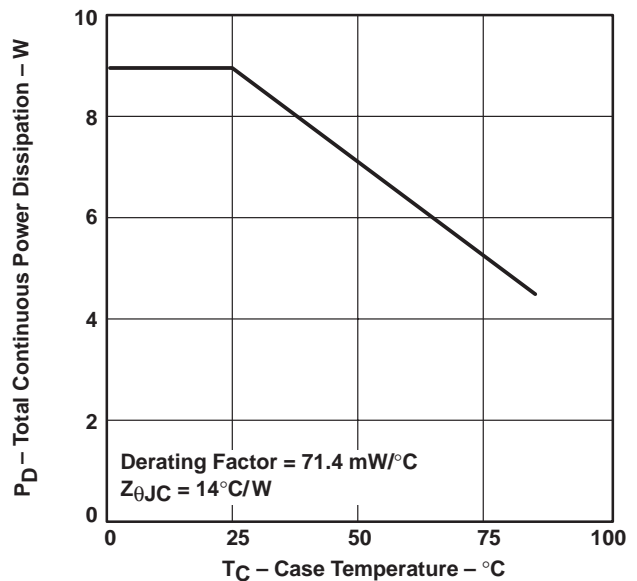

**TLE2301**  
**EXCALIBUR 3-STATE-OUTPUT WIDE-BANDWIDTH**  
**POWER OPERATIONAL AMPLIFIER**  
 SLOS131 – DECEMBER 1993

**recommended operating conditions**

		MIN	MAX	UNIT
Supply voltage, $V_{CC\pm}$		$\pm 4.5$	$\pm 20$	V
Common-mode input voltage, $V_{IC}$	$V_{CC\pm} = \pm 5$ V	-4	1.6	V
	$V_{CC\pm} = \pm 15$ V	-14	11.8	V
High-level 3-state enable voltage, $V_{IH}$		2		V
Low-level 3-state enable voltage, $V_{IL}$			0.8	V
Continuous output current			1	A
Operating free-air temperature, $T_A$		-40	85	°C

**electrical characteristics at specified free-air temperature,  $V_{CC\pm} = \pm 5$  V,  $C_C = 15$  pF (unless otherwise noted) (see Figure 5)**

PARAMETER		TEST CONDITIONS		$T_A^\dagger$	MIN	TYP	MAX	UNIT
$V_{IO}$	Input offset voltage	$V_O = 0,$ $R_S = 50 \Omega$	$V_{IC} = 0,$	25°C		0.4	7	mV
				Full range			10	
$I_{IB}$	Input bias current	$V_O = 0,$ $R_S = 50 \Omega$	$V_{IC} = 0,$	25°C		283	450	nA
				Full range			500	
$V_{ICR}$	Common-mode input voltage range	$R_S = 50 \Omega$		Full range	-4 to 1.6			V
$V_{OM+}$	Maximum positive peak output voltage swing	$R_L = 20 \Omega,$	See Note 6	25°C	3.3	3.5		V
				Full range	3.2			
$V_{OM-}$	Maximum negative peak output voltage swing	$R_L = 20 \Omega,$	See Note 6	25°C	-3.2	-3.4		V
				Full range	-3.1			
$A_{VD}$	Large-signal differential voltage amplification	$V_O = \pm 2$ V, $R_L = 20 \Omega$	$V_{IC} = 0,$	25°C	65	87		dB
				Full range	60			
$r_i$	Differential input resistance			25°C		1		M $\Omega$
$r_o$	Output resistance (see Note 7)	TRS1 = 0.8 V		25°C	1			$\Omega$
		TRS1 = 2 V,	3-state mode		100			
$CMRR$	Common-mode rejection ratio	$V_{IC} = V_{ICRmin},$ $R_S = 50 \Omega$	$V_O = 0,$	25°C	65	88		dB
$k_{SVR}$	Supply-voltage rejection ratio ( $\Delta V_{CC\pm} / \Delta V_{IO}$ )	$V_{CC\pm} = \pm 4.5$ V to $\pm 20$ V, $V_{IC} = 0,$	No load	25°C	70	100		dB
$I_{IH}$	Enable input current, high	$V_I = 2$ V,	3-state mode	25°C	0.01	0.5		$\mu$ A
				Full range			0.5	
$I_{IL}$	Enable input current, low	$V_I = 0.8$ V		25°C	0.01	0.5		$\mu$ A
				Full range			0.5	
$I_{OS}$	Short-circuit output current (see Note 8)	$V_O = 0,$	$t_p \leq 50 \mu$ s	25°C	1	1.8		A
$I_{CC}$	Supply current	$V_O = 0,$	No load	25°C		10	21	mA
				Full range			25	
		$V_O = 0,$	No load,	25°C		1.73	2.7	
				Full range			3.5	

$^\dagger$  Full range is -40°C to 85°C.

NOTES: 6. OUT1 and OUT2 are connected together for all tests.

7. TRS1 voltage is measured with respect to TRS2 potential.

8. Pulse testing techniques are used to maintain the junction temperature as close to the ambient temperature as possible. Thermal effects must be taken into account separately ( $t_p$  = pulse duration time).



**TLE2301**  
**EXCALIBUR 3-STATE-OUTPUT WIDE-BANDWIDTH**  
**POWER OPERATIONAL AMPLIFIER**

SLOS131 – DECEMBER 1993

**electrical characteristics at specified free-air temperature,  $V_{CC\pm} = \pm 15\text{ V}$ ,  $C_C = 15\text{ pF}$  (unless otherwise noted) (see Figure 5)**

PARAMETER		TEST CONDITIONS		$T_A^\dagger$	MIN	TYP	MAX	UNIT
$V_{IO}$	Input offset voltage	$V_O = 0,$ $R_S = 50\ \Omega$	$V_{IC} = 0,$	25°C	0.3	10		mV
				Full range		15		
$I_{IB}$	Input bias current	$V_O = 0,$ $R_S = 50\ \Omega$	$V_{IC} = 0,$	25°C	260	450		nA
				Full range		500		
$V_{ICR}$	Common-mode input voltage range	$R_S = 50\ \Omega$		Full range	-14 to 11.8			V
$V_{OM+}$	Maximum positive peak output voltage swing	$R_L = 20\ \Omega,$	See Note 6	25°C	13	13.5		V
				Full range	13			
$V_{OM-}$	Maximum negative peak output voltage swing	$R_L = 20\ \Omega,$	See Note 6	25°C	-12.6	-13		V
				Full range	-12.5			
$A_{VD}$	Large-signal differential voltage amplification	$V_O = \pm 6\text{ V},$ $R_L = 20\ \Omega$	$V_{IC} = 0,$	25°C	70	102		dB
				Full range	65			
$r_i$	Differential input resistance			25°C		1		M $\Omega$
$r_o$	Output resistance (see Note 7)	TRS1 = 0.8 V		25°C		1		$\Omega$
		TRS1 = 2 V, 3-state mode				100		k $\Omega$
$CMRR$	Common-mode rejection ratio	$V_{IC} = V_{ICRmin},$	$V_O = 0,$	25°C	70	97		dB
$k_{SVR}$	Supply-voltage rejection ratio ( $\Delta V_{CC\pm} / \Delta V_{IO}$ )	$V_{CC\pm} = \pm 4.5\text{ V to } \pm 20\text{ V},$	$V_{IC} = 0,$	25°C	70	100		dB
$I_{IH}$	Enable input current, high	$V_I = 2\text{ V},$	3-state mode	25°C	0.01	0.5		$\mu\text{A}$
				Full range		0.5		
$I_{IL}$	Enable input current, low	$V_I = 0.8\text{ V}$		25°C	0.01	0.5		$\mu\text{A}$
				Full range		0.5		
$I_{OS}$	Short-circuit output current (see Note 8)	$V_O = 0,$	$t_p \leq 50\ \mu\text{s}$	25°C	1	3		A
$I_{CC}$	Supply current	$V_O = 0,$	No load	25°C	11	25		mA
				Full range		30		
		25°C	No load, 3-state mode		2.2	3.5		
				Full range		5		

$^\dagger$  Full range is -40°C to 85°C.

NOTES: 6. OUT1 and OUT2 are connected together for all tests.

7. TRS1 voltage is measured with respect to TRS2 potential.

8. Pulse testing techniques are used to maintain the junction temperature as close to the ambient temperature as possible. Thermal effects must be taken into account separately ( $t_p$  = pulse duration time).



**TLE2301**  
**EXCALIBUR 3-STATE-OUTPUT WIDE-BANDWIDTH**  
**POWER OPERATIONAL AMPLIFIER**

SLOS131 – DECEMBER 1993

**operating characteristics at specified free-air temperature,  $V_{CC\pm} = \pm 5\text{ V}$ ,  $C_C = 15\text{ pF}$ ,  $T_A = 25^\circ\text{C}$  (unless otherwise noted) (see Figure 5)**

PARAMETER		TEST CONDITIONS	MIN	TYP	MAX	UNIT
SR	Slew rate at unity gain (see Figure 1)	$V_O = \pm 1.5\text{ V}$ , $R_L = 20\ \Omega$ , $C_L = 100\text{ pF}$	9	12		V/ $\mu\text{s}$
$t_s$	Settling time (see Figure 1)	$R_L = 20\ \Omega$ , $C_L = 100\text{ pF}$ , 3-V step to 30 mV (1%)		0.7		$\mu\text{s}$
$V_n$	Equivalent input noise voltage (see Figure 2)	$R_S = 50\ \Omega$ , $f = 1\text{ kHz}$		44		nV/ $\sqrt{\text{Hz}}$
THD	Total harmonic distortion	$V_O = 1\text{ V}_{\text{rms}}$ , $f = 50\text{ kHz}$ , $R_L = 20\ \Omega$ , $C_L = 100\text{ pF}$		0.04%		
$B_1$	Unity-gain bandwidth (see Figure 3)	$R_L = 20\ \Omega$ , $C_L = 100\text{ pF}$		8		MHz
$\phi_m$	Phase margin at unity gain (see Figure 3)	$R_L = 20\ \Omega$ , $C_L = 100\text{ pF}$		30°		

**operating characteristics at specified free-air temperature,  $V_{CC\pm} = \pm 15\text{ V}$ ,  $C_C = 15\text{ pF}$ ,  $T_A = 25^\circ\text{C}$  (unless otherwise noted) (see Figure 5)**

PARAMETER		TEST CONDITIONS	MIN	TYP	MAX	UNIT
SR	Slew rate at unity gain (see Figure 1)	$V_O = \pm 10\text{ V}$ , $R_L = 20\ \Omega$ , $C_L = 100\text{ pF}$	9	14		V/ $\mu\text{s}$
$t_s$	Settling time (see Figure 1)	$R_L = 20\ \Omega$ , $C_L = 100\text{ pF}$ , 20-V step to 200 mV (1%)		1.8		$\mu\text{s}$
$V_n$	Equivalent input noise voltage (see Figure 2)	$R_S = 50\ \Omega$ , $f = 1\text{ kHz}$		44		nV/ $\sqrt{\text{Hz}}$
THD	Total harmonic distortion	$V_O = 2\text{ V}_{\text{rms}}$ , $f = 50\text{ kHz}$ , $R_L = 20\ \Omega$ , $C_L = 100\text{ pF}$		0.08%		
$B_1$	Unity-gain bandwidth (see Figure 3)	$R_L = 20\ \Omega$ , $C_L = 100\text{ pF}$		8		MHz
$\phi_m$	Phase margin at unity gain (see Figure 3)	$R_L = 20\ \Omega$ , $C_L = 100\text{ pF}$		35°		

PARAMETER MEASUREMENT INFORMATION

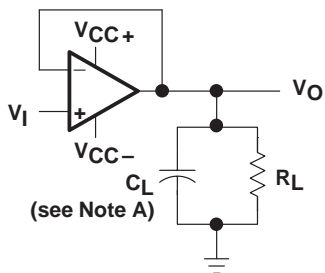

NOTE A:  $C_L$  includes the fixture capacitance.

Figure 2. Slew-Rate Test Circuit

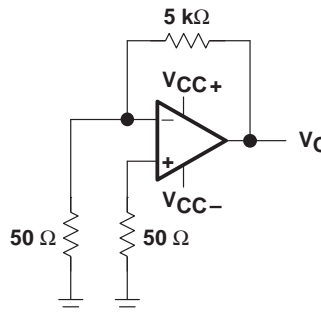
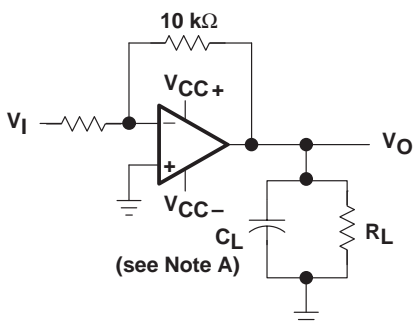

Figure 3. Noise-Voltage Test Circuit



NOTE A:  $C_L$  includes the fixture capacitance.

Figure 4. Gain-Bandwidth and Phase-Margin Test Circuit

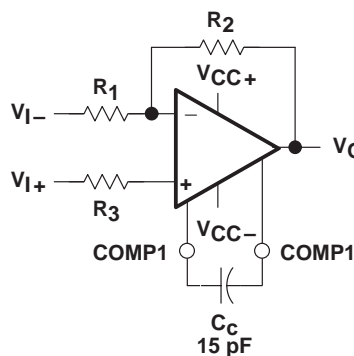

Figure 5. Compensation Configuration

typical values

Typical values presented in this data sheet represent the median (50% point) of the device parametric performance.

**TYPICAL CHARACTERISTICS**

**Table of Graphs**

		<b>FIGURE</b>	
$I_{IB}$	Input bias current	vs Free-air temperature	6, 7
$I_{IO}$	Input offset current	vs Free-air temperature	6, 7
$A_{VD}$	Differential voltage amplification	vs Frequency	8
		vs Free-air temperature	9
$V_{O(PP)}$	Maximum peak-to-peak output voltage	vs Frequency	10, 11
$V_{OM}$	Maximum peak output voltage	vs Output current	12, 13
		vs Supply voltage	14
$Z_{\theta JA}$	Transient junction-to-ambient thermal impedance	vs Time	15
$I_{CC}$	Supply current	vs Supply voltage	16
		vs Free-air temperature	17
	Pulse response	Small signal	18, 19
		Large signal	20, 21
$Z_o$	Output impedance	vs Frequency	22, 23

**INPUT BIAS CURRENT AND  
 INPUT OFFSET CURRENT  
 vs  
 FREE-AIR TEMPERATURE**

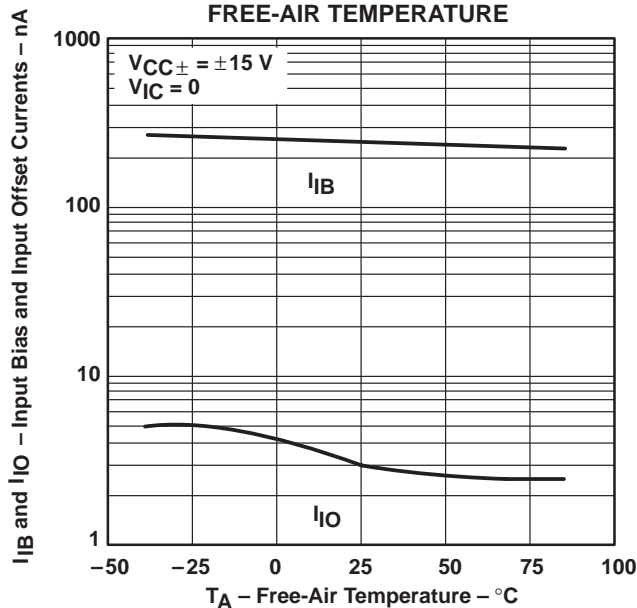

**Figure 6**

**INPUT BIAS CURRENT AND  
 INPUT OFFSET CURRENT  
 vs  
 FREE-AIR TEMPERATURE**

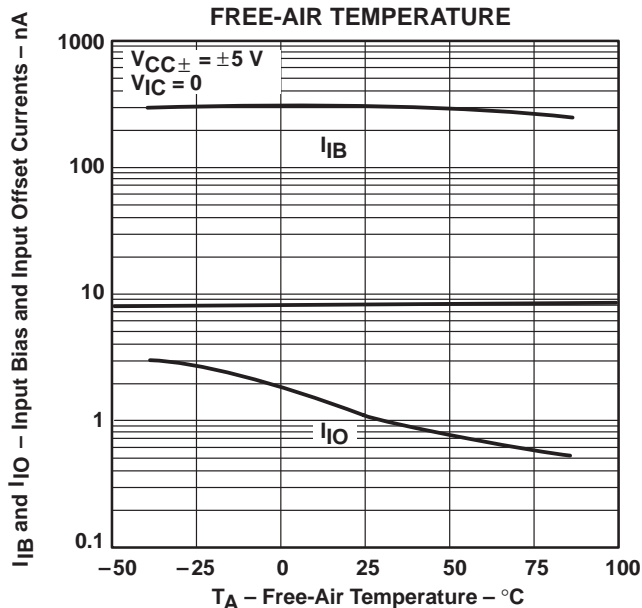

**Figure 7**

TYPICAL CHARACTERISTICS

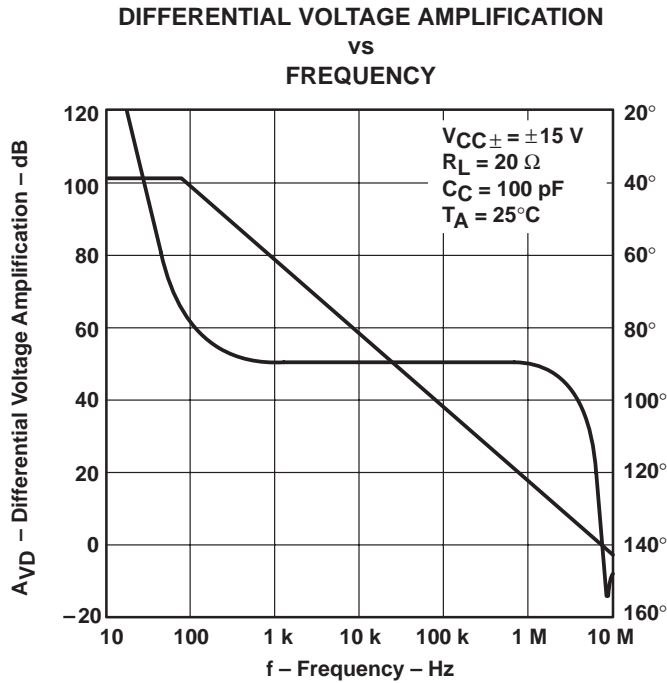

Figure 8

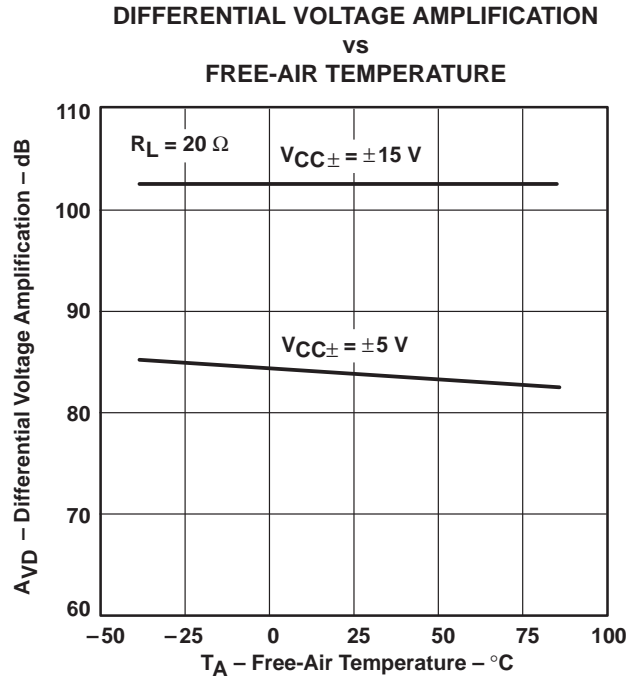

Figure 9

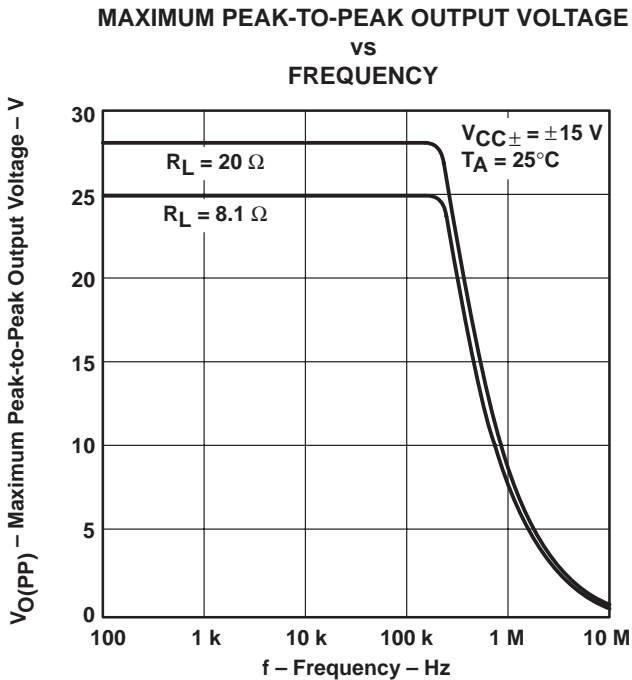

Figure 10

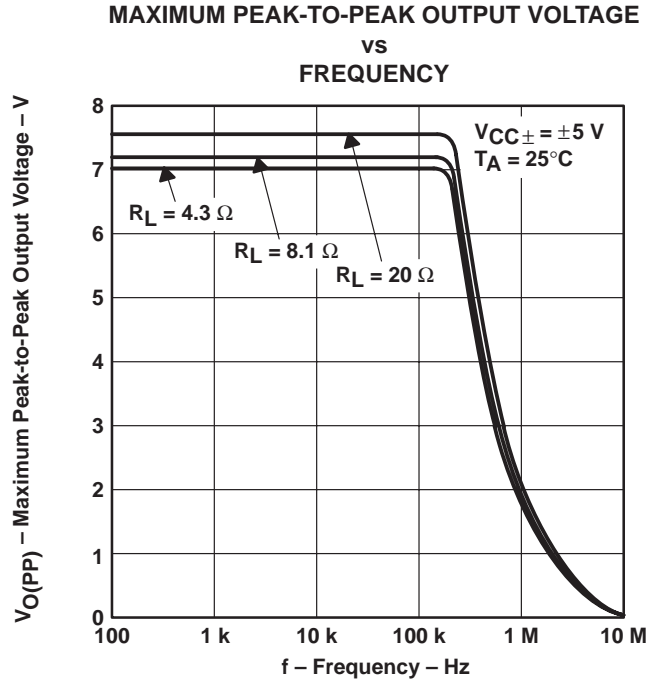

Figure 11

**TYPICAL CHARACTERISTICS**

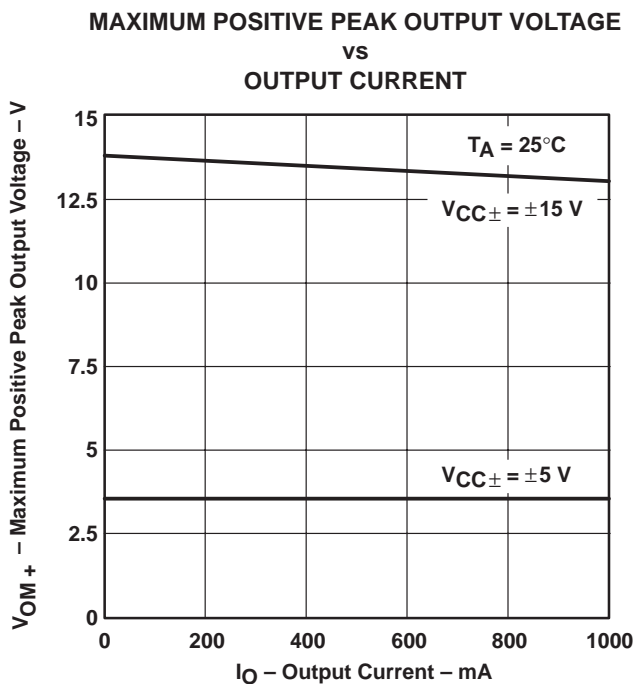

Figure 12

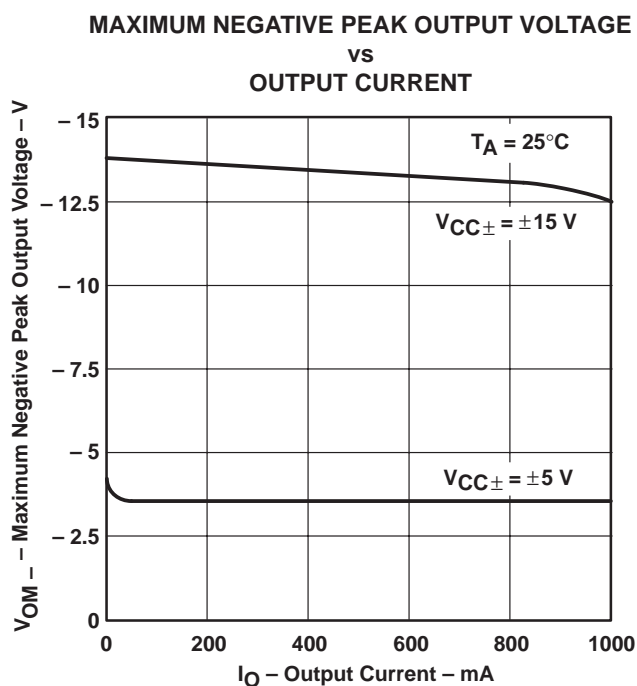

Figure 13

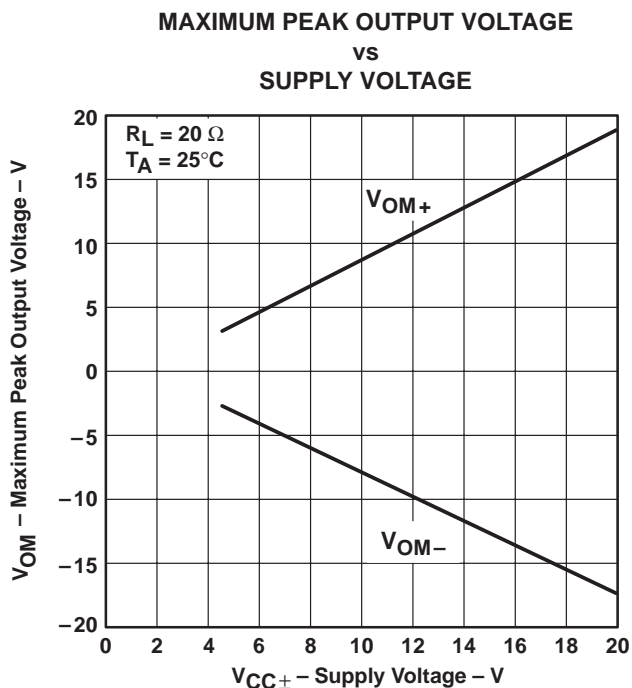

Figure 14

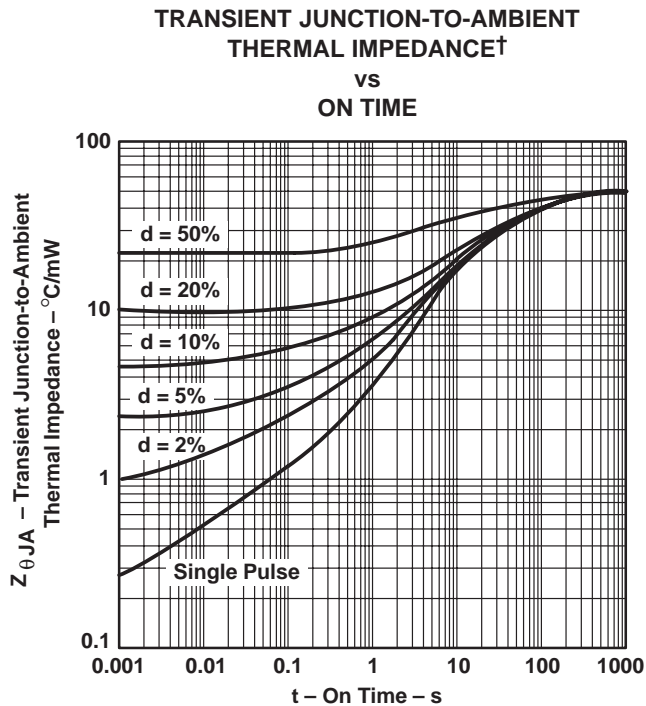

Figure 15

† d = duty cycle

TYPICAL CHARACTERISTICS

SUPPLY CURRENT  
 vs  
 SUPPLY VOLTAGE

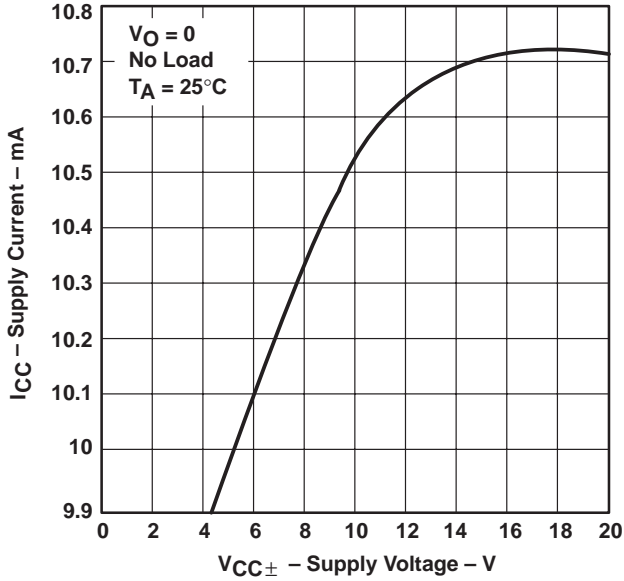

Figure 16

SUPPLY CURRENT  
 vs  
 FREE-AIR TEMPERATURE

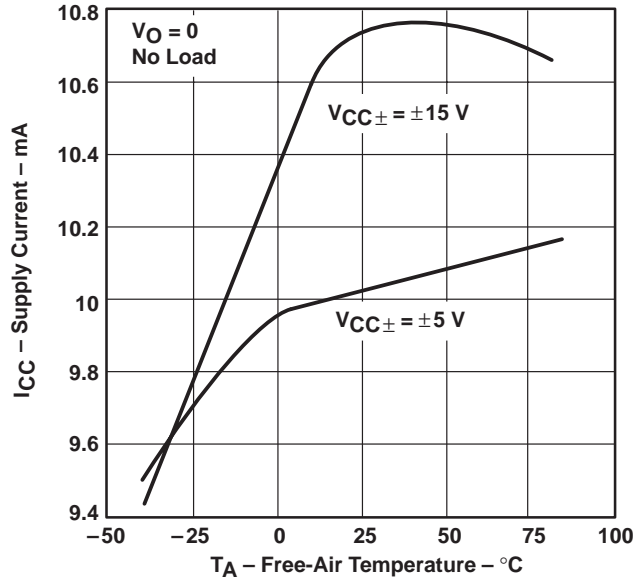

Figure 17

VOLTAGE FOLLOWER  
 SMALL-SIGNAL  
 PULSE RESPONSE

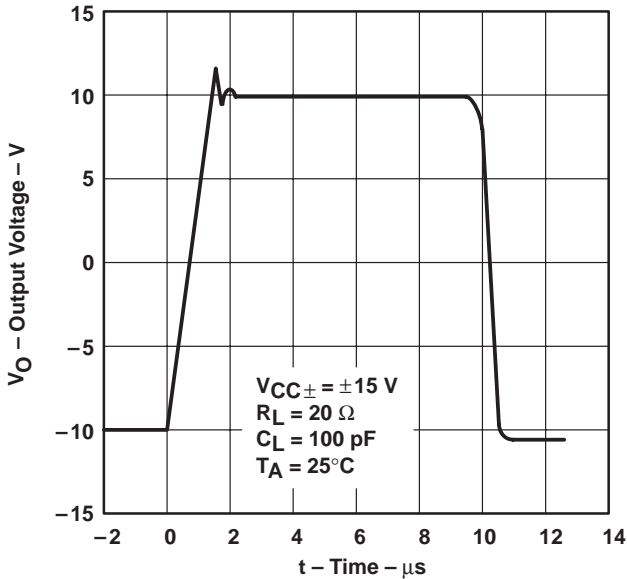

Figure 18

VOLTAGE FOLLOWER  
 SMALL-SIGNAL  
 PULSE RESPONSE

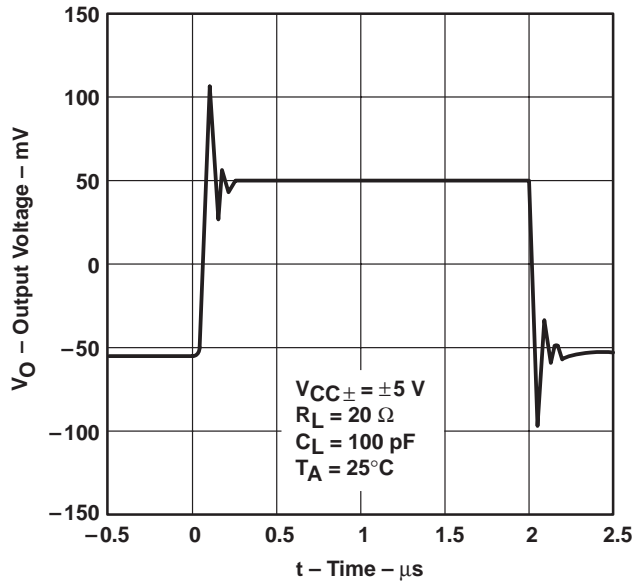

Figure 19

TYPICAL CHARACTERISTICS

VOLTAGE FOLLOWER  
 LARGE-SIGNAL  
 PULSE RESPONSE

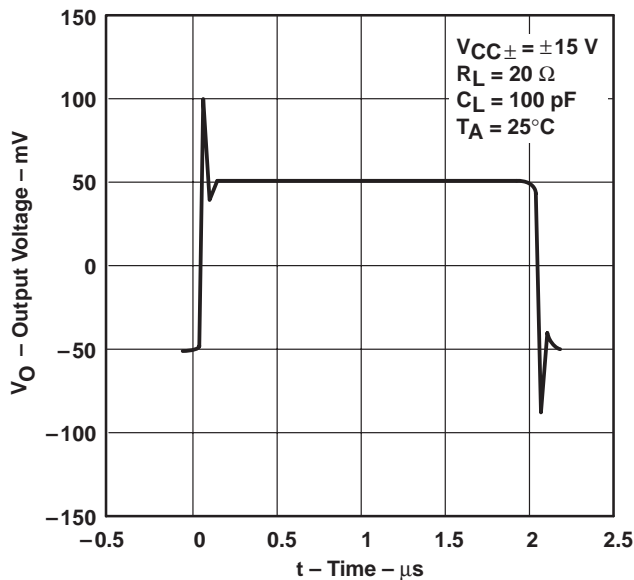

Figure 20

VOLTAGE FOLLOWER  
 LARGE-SIGNAL  
 PULSE RESPONSE

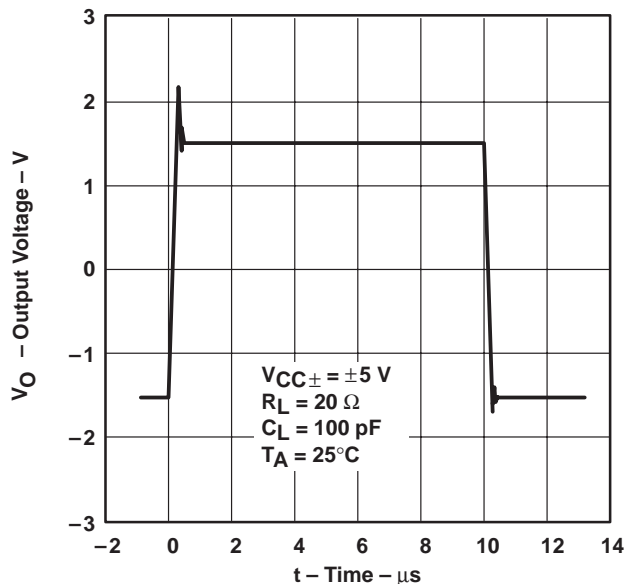

Figure 21

OUTPUT IMPEDANCE  
 vs  
 FREQUENCY

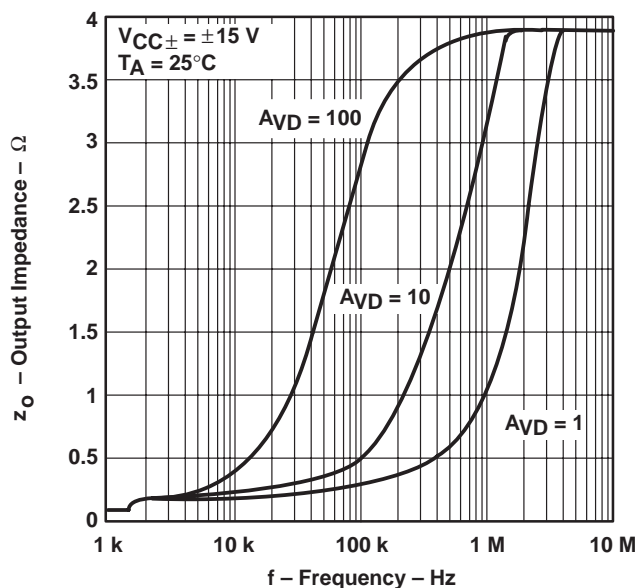

Figure 22

OUTPUT IMPEDANCE  
 vs  
 FREQUENCY

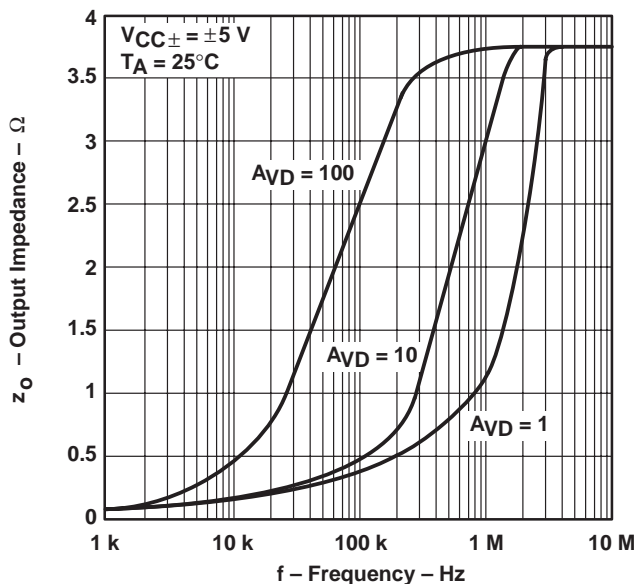

Figure 23

## APPLICATION INFORMATION

### circuit for mains-line driver over 40-kHz-to-90-kHz utility band

The following application is a circuit for a *mains-line driver over 40-kHz-to-90-kHz utility band* and is based around the European standard (EN56065–1) describing utility and consumer applications. This example shows a possible implementation for differential transmission on the mains line. This applications circuit is designed around the requirements of a domestic electricity meter operating over a utility band of 40 kHz to 90 kHz. A dual-rail power supply of  $\pm 5$  V is used for this design example to limit device power dissipation. The same design principles, however, can be applied to other applications.

### frequency band

The frequency band for utility applications extends over an enormous range from 3 kHz to 95 kHz. In order to have a coupling network that is economical and implemented with readily available components, this circuit is designed for a subband from 40 kHz to 90 kHz.

This subband is sufficiently wide to support multichannel operation; i.e., 10 channels of 5 kHz width or more if the channel widths are smaller. To avoid transmission spillover into the next band, a guard band of 5 kHz is allowed. The upper frequency of this circuit is set to 90 kHz, and the lower frequency is chosen for an economical coupling network and still has sufficient bandwidth to support multichannel operation.

### output drive

The impedance of the mains network at these signalling frequencies is relatively low ( $<1 \Omega$  to  $30 \Omega$ ). This circuit has been designed to drive a 4- $\Omega$  mains line over the 40-kHz-to-90-kHz bandwidth.

The signalling impedance of the mains network fluctuates as different loads are switched on during the day or over a season, and it is influenced by many factors such as:

- Localized loading from appliances connected to the mains supply near to the connection of the communication equipment; e.g., heavy loads such as cookers and immersion heaters and reactive loads such as EMC filters and power factor correctors
- Distributed loading from consumers connected to the same mains cable, where their collective loading reduces the mains signalling impedance during times of peak electricity consumption; e.g., meal times
- Network parameters; e.g., transmission properties of cables and the impedance characteristics of distribution transformers and other system elements

With such a diversity of factors, the signalling environment fluctuates enormously, irregularly, and can differ greatly from one installation to another. The signalling system should be designed for reliable communications over a wide range of mains impedances and signalling conditions. Consequently, the transmitter must be able to drive sufficient signal into the mains network under these loading conditions.

The TLE2301 amplifier has 1-A output drive capability with short-circuit protection; hence, it adequately copes with the high current demands required for implementing mains signalling systems.

### 3-state facility

When transmitting, the transmitter appears as a low-impedance signal source on the mains network. If transmitters are left in the active mode whether transmitting or not and a large number of transmitters are installed in close proximity, their combined loading would reduce the mains impedance to unacceptable levels. Not only would each transmitter need to drive into an extremely low mains impedance, but signals arriving from distant transmitters would be severely attenuated.

To overcome this problem, the transmitters need to present a high impedance to the mains network when they are not transmitting. The mains network is then only loaded by a few transmitters at any one time, and the mains signalling impedance is not adversely affected.

## APPLICATION INFORMATION

### 3-state facility (continued)

The TLE2301 incorporates an output 3-state facility, removing the need for additional circuitry to achieve this function. In addition, the TLE2301 has a low standby current in the 3-state mode, making it ideal for applications where low power consumption is also essential.

### circuit configuration

The design methodology is to minimize power dissipation in the TLE2301 by maximizing the use of the available output voltage swing of the amplifier. The amplifier's output can swing to within 2 V of the supply rail before saturation begins. With a chosen supply of  $\pm 5$  V, the maximum peak-to-peak voltage swing is 6 V. To ensure that the amplifier's output is not likely to clip under heavy loads, the maximum output voltage swing has been reduced by 0.5 V, giving a usable peak-to-peak output voltage swing of 5.5 V.

It is assumed that the input signal to the transmitter stage has a peak-to-peak amplitude of 2.8 V (1 Vrms) as might be expected if the transmission signal is digitally synthesized by circuitry operating solely from the 5-V supply. The gain of the amplifier stage is appropriately set to:

$$\begin{aligned} \text{Gain} &= \frac{\text{peak-to-peak output voltage swing}}{\text{peak-to-peak input voltage}} \\ &= \frac{5.5 \text{ V}}{2.8 \text{ V}} \\ &= 1.96 \end{aligned}$$

An inverting amplifier configuration is chosen for this example, as the input signal source is assumed to have a relatively low impedance in relation to the gain-setting resistors.

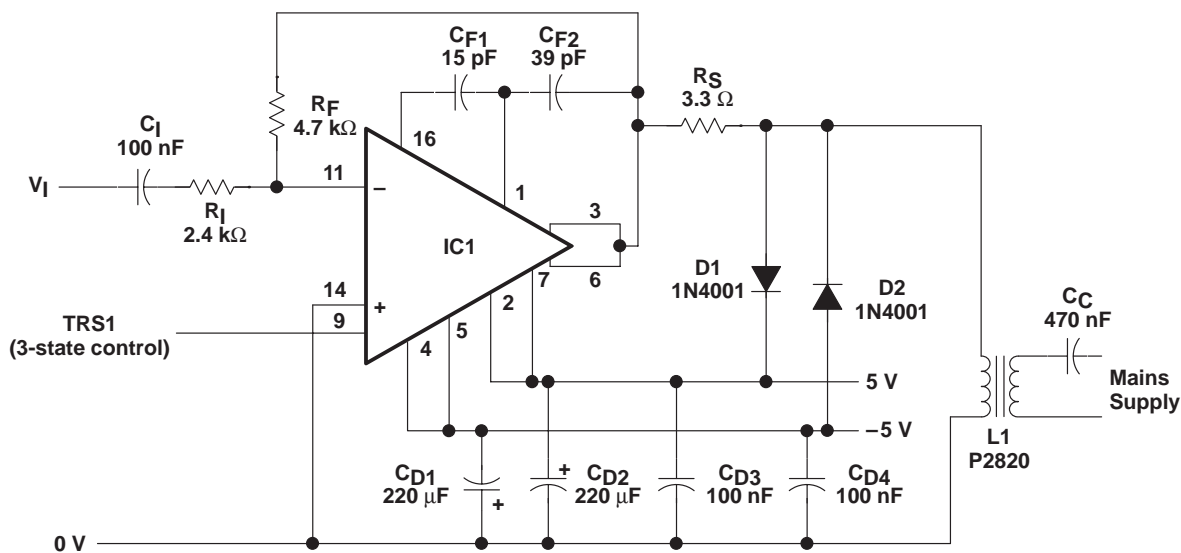

**Figure 24. Full-Circuit Diagram for Utility Band**

A noninverting amplifier configuration could be used when the input signal needs to be terminated with high impedance, but the user should take care that the amplitude of the input signal does not exceed the common-mode input range ( $-4 \text{ V} < V_{ICM} < 1.8 \text{ V}$  at  $V_{CC} = \pm 5 \text{ V}$ ) for low-gain implementations.

# TLE2301 EXCALIBUR 3-STATE-OUTPUT WIDE-BANDWIDTH POWER OPERATIONAL AMPLIFIER

SLOS131 – DECEMBER 1993

## APPLICATION INFORMATION

### component calculations

The following sections contain the calculations for input capacitors, gain resistors, coupling network, coupling capacitors, transformer-leakage inductance, series resistors, decoupling, and frequency compensation.

#### *input capacitor*

The incoming signal is ac coupled to remove any incoming dc offset and to provide only unity gain for the amplifier's input offset voltage. The value of 100 nF is chosen for this input capacitor as it has very little influence on the amplifier's signal gain over the frequency band.

#### *gain resistors*

The gain-setting resistors are chosen for a gain of 1.96; i.e., choosing:

$$\text{Gain} = \frac{R_F}{R_I}$$

$$R_F = 4.7 \text{ k}\Omega \text{ and } R_I = 2.4 \text{ k}\Omega$$

$$= \frac{4.7 \text{ k}\Omega}{2.4 \text{ k}\Omega}$$

$$= 1.96$$

The resistor values are low enough to ensure that the circuit does not suffer from stray capacitance and signal pick-up problems but not too low as to significantly load the mains impedance when the amplifier is in its high-impedance state.

#### *coupling network*

The function of the line interface is to provide isolation from the mains supply while coupling the communication signals onto the mains network. As the mains voltage is large in comparison with the communication signals, the mains voltage needs to be isolated from the electronic circuitry. The simple coupling network limits the current flowing from the mains supply as well as providing a convenient point at which to implement the safety isolation barrier between the mains supply and the communications circuitry. The transformer can easily achieve an isolation of 4 kV between primary and secondary windings, and the capacitor provides the low frequency roll-off to impede the mains voltage.

The transformer has two other useful properties. First, the turns ratio can be selected to provide efficient power transfer between the TLE2301 amplifier and the mains network. Second, the transformer possesses leakage inductance that can be tuned with the coupling capacitor to form a band-pass filter.

By altering the turns ratio, the power dissipated in the TLE2301 can be reduced while maintaining the required voltage levels on the mains line. A turns ratio of 1.67:1 was selected in this design to apply a 120- $\mu$ dBV signal onto the mains line. The calculation for the turns ratio is not straightforward due to the presence of numerous complex impedances. The simplest method for deriving the turns ratio is to model the circuit with an analog simulation program such as PSpice™. It is from these simulations that the 1.67:1 turns ratio has been selected.

PSpice is a registered trademark of MicroSim Corporation.



POST OFFICE BOX 655303 • DALLAS, TEXAS 75265

## APPLICATION INFORMATION

### ***coupling capacitor***

With such a wide frequency band, the quality factor of the coupling filter needs to be low in order to avoid unacceptably large attenuation at the band edges and to achieve a good coupling performance that is insensitive to a wide range of loads. For a band-pass filter of this configuration, the quality factor is proportional to the reciprocal of the coupling capacitance. For low Q, the value of  $C_C$  needs to be large.

$Q$  = quality factor and  $C_C$  = coupling capacitor

$$Q \propto \frac{1}{C_C}$$

Counterbalancing this need for a large value of  $C_C$  creates two more considerations. First, the capacitance should not be so large as to allow significant 50-Hz mains current through the transformer ( $I = 2 \times \pi \times f \times C_C \times V$ ). Second, the coupling capacitor is required to meet certain safety standards. The coupling capacitor is actually an RFI-suppression capacitor that has been designed by the manufacturers to provide an adequate level of protection when connected across the various conductors of the mains supply (consult the UL1283 or UL1414 standards for RFI capacitors). These types of capacitors can be expensive, physically large, restricted in capacitance value, and limited in the number of manufacturers.

As a reasonable compromise between all these factors, a coupling capacitor of 470 nF is chosen. This value is multisourced, moderately priced, limits the mains current through the transformer to less than 36 mA rms, and has sufficient capacitance to form the desired low-Q filter.

### ***transformer leakage inductance***

The transformer leakage inductance, inherent to the transformer, can be used to form an LC band-pass filter. If the capacitor alone is used to couple onto the mains network, its capacitance value needs to be quite large for it to have a reasonably low reactance at the signalling frequencies. Forming an LC filter greatly reduces the value of capacitor required. The center frequency of the filter is not the same as the midband frequency of 65 kHz. Band-pass filters show a symmetrical shape only when plotted against the logarithm of frequency, so the center frequency ( $f_o$ ) is given by the following formula:

$$\begin{aligned} f_o &= \sqrt{f_{\text{lower}} \times f_{\text{upper}}} \\ &= \sqrt{(40 \times 90) \text{ kHz}} \\ &= 60 \text{ kHz} \end{aligned}$$

The leakage inductance of the transformer, as viewed from the winding connected to the coupling capacitor, is derived from  $2\pi f_o = 1/\sqrt{LC}$ . The required leakage inductance of the transformer is:

$$\begin{aligned} L &= \frac{1}{(2\pi f_o)^2 \times C_C} \\ &= \frac{1}{(2\pi \times 60 \text{ kHz})^2 \times 470 \text{ nF}} \\ &= 15 \mu\text{H} \end{aligned}$$

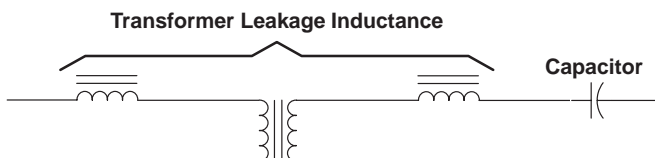

**Figure 25. Band-Pass Coupling Filter**

---

## APPLICATION INFORMATION

### *series resistor*

The series resistor,  $R_S$ , is included to limit the turn-on current, the amplifier's offset current, and the signalling current through the filter. With dual supply rails, there is always a potential problem of large turn-on currents as the amplifier powers up. If one supply rail turns on before the other, the output of the TLE2301 amplifier could saturate near to the applied supply rail, causing a large current to flow through the transformer winding ( $R_{winding} = 0.1 \Omega$  for the P2820 transformer). The power supply needs to be of sufficient rating to ensure that its rails could rise to the minimum operating voltage of the amplifier, at which point the amplifier is ensured to have returned to stable operation.

With a series resistor of  $3.3 \Omega$  and assuming the output saturates at the maximum peak-to-peak voltage excursion of  $3 \text{ V}$ , this turn-on current is limited to less than the device's 1-A rating ( $I_{transient} = 3 \text{ V}/3.3 \Omega = 0.91 \text{ A}$ ). Further reduction of this turn-on current by raising the value of the series resistor deteriorates the filter's performance into low signalling impedances on the mains network.

Alternatively, this turn-on current could be blocked by means of a series capacitor, but for this frequency band the capacitor has to be large in value ( $\geq 3.3 \mu\text{F}$ ) so as not to adversely affect the filter. A nonpolarized capacitor of this value is relatively expensive, and the resistor is still required to fulfill other functions.

Another way of preventing overcurrent at power up is to use the TLE2301 3-state mode. As the TRS2 control line is intended to be tied to the microprocessor's 0-V rail, the TRS1 control line must be taken high to activate the 3-state mode, which implies that the positive rail is required to turn on first. Other schemes could be devised to take TRS2 below the 0-V rail until the power supply has stabilized if the negative rail turns on first. Instead of relying on a definite power-supply sequence or elaborate control circuitry, it is simpler to limit the current either with a series resistor or capacitor.

The second function of the series resistor is to limit the dc current flow through the transformer winding due to the dc offset at the amplifier's output, which is caused by its input offset voltage. For a worst case input offset of  $20 \text{ mV}$ , the output offset is also  $20 \text{ mV}$  as the dc gain of the circuit is unity. Offsets due to input bias currents are negligible since the values of the gain-setting resistors are low. The dc current through the transformer is therefore less than  $7 \text{ mA}$  ( $20 \text{ mV}/3.3 \Omega$ ). This low level of dc current does not appreciatively increase the power dissipation of the amplifier or noticeably diminish the harmonic performance of the transformer.

The final function of the series resistor is to limit the signalling current in the event that the mains impedance might appear as solely reactive; i.e., without a resistive component. As a rough estimate, the peak signal current from the amplifier is:

$$I_{OM} = \frac{V_{O(PP)}}{R_S} = \frac{\left(\frac{5.5 \text{ V}}{2}\right)}{3.3 \Omega} = 833 \text{ mA}$$

where:

$V_{O(PP)}$  = Peak-to-peak output voltage swing

$I_{OM}$  = Peak-output-signalling current from amplifier

## APPLICATION INFORMATION

### *series resistor (continued)*

Again, the value of the series resistor is sufficient to limit the peak-signal current below the device's maximum rating. This calculation does not take into account other resistive impedances in the signal path, which would further reduce the peak signal current from the amplifier.

### *decoupling*

Power-supply decoupling for the amplifier is provided by a 220- $\mu\text{F}$  electrolytic capacitor and a 100-nF ceramic capacitor per supply rail located close to the supply terminals of the TLE2301 device.

The decoupling capacitors for the negative supply should be connected to a pair of  $V_{CC-}$  terminals (4 and 5 or 12 and 13), whichever pair is most convenient from a printed-circuit-board (PCB) layout point of view. In order to minimize parasitic lead inductances, these capacitors should be located as close as possible to the device terminals to which they are connected. As the  $V_{CC+}$  terminals are not adjacent on the package, the decoupling capacitors should be connected to one terminal with a thick PCB track going to the other terminal.

The 220- $\mu\text{F}$  electrolytic capacitor is chosen to provide good decoupling performance (less than 25-mV ripple under the worst-case loading for the utility circuit). This value could be reduced to 100  $\mu\text{F}$  for higher-frequency consumer bands. The level of ripple depends on the source impedance of the power supply and the equivalent series resistance of the chosen decoupling capacitors. The 100-nF ceramic capacitor provides high-frequency decoupling for the amplifier.

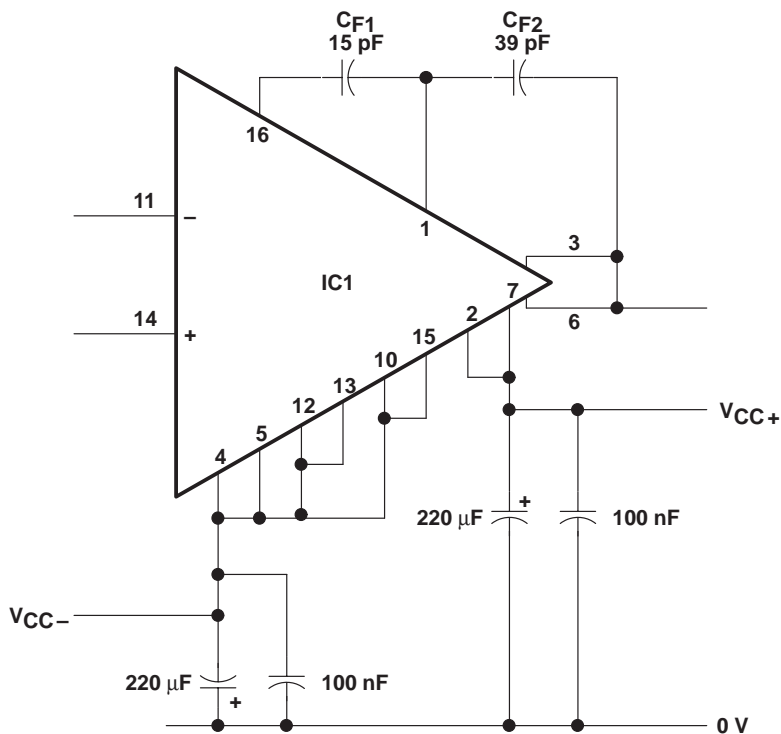

Figure 26. Amplifier Decoupling and Compensation

**TLE2301**  
**EXCALIBUR 3-STATE-OUTPUT WIDE-BANDWIDTH**  
**POWER OPERATIONAL AMPLIFIER**

SLOS131 – DECEMBER 1993

**APPLICATION INFORMATION**

**frequency compensation**

The TLE2301 amplifier requires one compensation capacitor. However, when driving heavy loads, stability can be increased by connecting  $V_{CC-}$  terminals 10 and 15 to  $V_{CC-}$  terminals 12 and 13 and using another capacitor between COMP2 and the outputs. The circuit included in this application has been designed with two compensation capacitors. The component values chosen are:

$$C_{F1} = 15 \text{ pF}$$

$$C_{F2} = 33 \text{ pF}$$

These component values could be adjusted if the amplifier is used for higher-frequency applications.

**power dissipation**

The impedance of the mains network fluctuates greatly for many reasons, but its impedance at the supply-distribution transformer is typically very low, less than 1  $\Omega$ , whereas the mains impedance in a house commonly has a higher value, from 4  $\Omega$  to 40  $\Omega$ . For utility-metering applications, a master transmitter may be sited at the supply-distribution transformer and would need to deliver more power into the mains network than the household transmitter when generating comparable signal amplitudes.

**NE thermally-enhanced dual in-line package**

The TLE2301 utilizes the four center terminals of the dual-in-line package (NE) to transfer heat to a copper area on the PCB. A copper area of 1290 mm<sup>2</sup> provides a junction-to-ambient thermal impedance,  $Z_{\theta JA}$ , of 34°C/W, allowing the device to dissipate up to 1.9 W at 85°C for a junction temperature of 150°C or up to 1.5 W at 85°C for a junction temperature of 135°C.

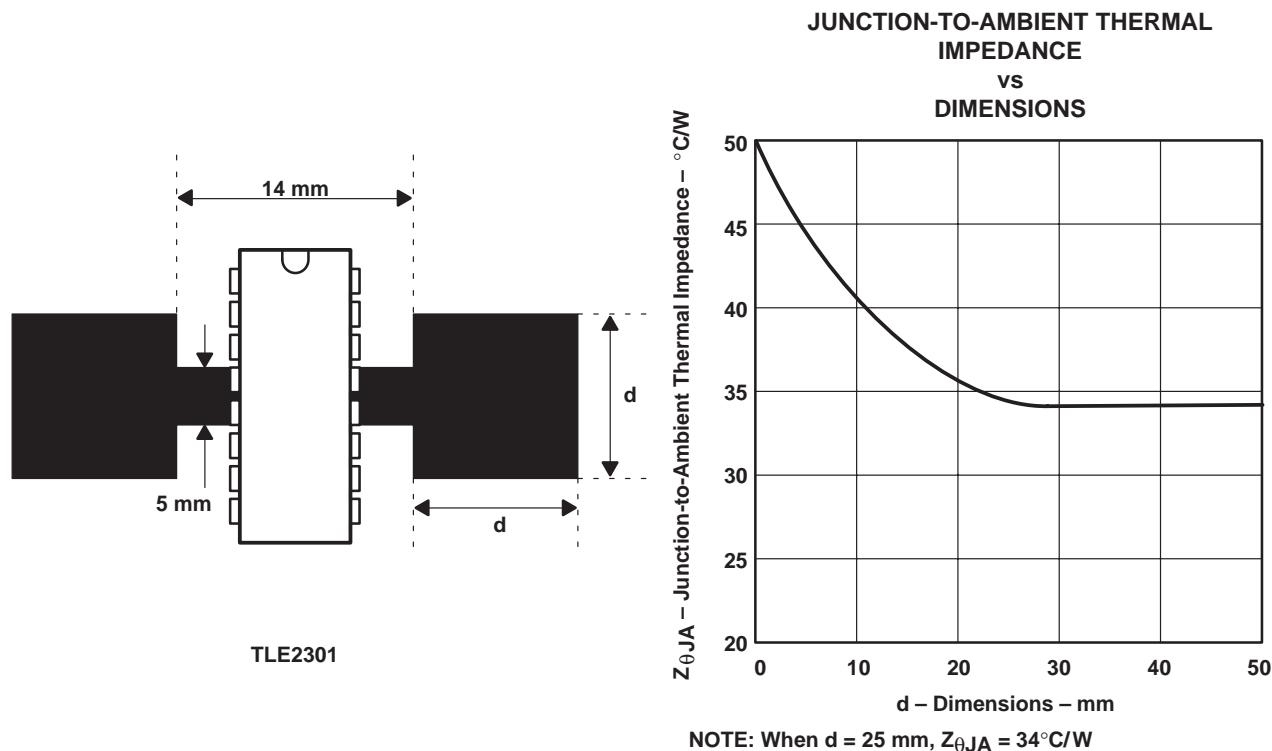

Figure 27. PCB Heatsink

## APPLICATION INFORMATION

### **power dissipation in amplifier**

For sinusoidal waveforms, the dissipation in the amplifier,  $P_{AMP}$ , is:

$$P_{AMP} = (2 \times V_{CC} \times I_{CC}) + \frac{(2 \times V_{CC} \times I_{OM})}{\pi} - P_O$$

where:

$I_{CC}$  = Amplifier's quiescent current

$I_{OM}$  = Peak-output-signalling current from amplifier

$P_O$  = Output power consumed by coupling network and load

The power dissipated in the amplifier is minimized if the amplifier's peak output current,  $I_{OM}$ , is minimized. Since the output power consumed by the coupling and load is a function of current and voltage ( $P_O \approx I_O \times V_O$ ), the amplifier's peak output current can be minimized by maximizing the amplifier's output voltage swing.

### **circuit parts list**

The associated parts list is:

REFERENCE	FIGURE	COMPONENT	DESCRIPTION
IC1	Figure 24, Figure 26	TLE2301 operational amplifier	Texas Instruments TLE2301NE
L1	Figure 24	1.67:1, 15- $\mu$ H leakage transformer	Electronics Techniques P2820 (European manufacturer)
C <sub>C</sub>	Figure 24	470-nF capacitor	Metalized paper, safety standards UL1414
C <sub>I</sub>	Figure 24	100-nF capacitor	Ceramic, general purpose
C <sub>F1</sub>	Figure 24, Figure 26	15-pF capacitor	Ceramic, general purpose
C <sub>F2</sub>	Figure 24, Figure 26	39-pF capacitor	Ceramic, general purpose
C <sub>D1</sub> , C <sub>D2</sub>	Figure 24	220- $\mu$ F, 10-V min capacitors	Aluminum electrolytic, general purpose
C <sub>D3</sub> , C <sub>D4</sub>	Figure 24	100-nF capacitors	Ceramic, general purpose
R <sub>F</sub>	Figure 24	4.7-k $\Omega$ , 0.125-W min resistor	Metal film, general purpose
R <sub>I</sub>	Figure 24	2.4-k $\Omega$ , 0.125-W min resistor	Metal film, general purpose
R <sub>S</sub>	Figure 24	3.3-k $\Omega$ , 1-W min, resistor	
D1, D2	Figure 24	1N4001 series, 1-A min diodes	General purpose

**PACKAGING INFORMATION**

Orderable Device	Status <sup>(1)</sup>	Package Type	Package Drawing	Pins	Package Qty	Eco Plan <sup>(2)</sup>	Lead/Ball Finish	MSL Peak Temp <sup>(3)</sup>
TLE2301INE	ACTIVE	PDIP	NE	16	25	Pb-Free (RoHS)	CU NIPDAU	N / A for Pkg Type
TLE2301INEE4	ACTIVE	PDIP	NE	16	25	Pb-Free (RoHS)	CU NIPDAU	N / A for Pkg Type

<sup>(1)</sup> The marketing status values are defined as follows:

**ACTIVE:** Product device recommended for new designs.

**LIFEBUY:** TI has announced that the device will be discontinued, and a lifetime-buy period is in effect.

**NRND:** Not recommended for new designs. Device is in production to support existing customers, but TI does not recommend using this part in a new design.

**PREVIEW:** Device has been announced but is not in production. Samples may or may not be available.

**OBsolete:** TI has discontinued the production of the device.

<sup>(2)</sup> Eco Plan - The planned eco-friendly classification: Pb-Free (RoHS), Pb-Free (RoHS Exempt), or Green (RoHS & no Sb/Br) - please check <http://www.ti.com/productcontent> for the latest availability information and additional product content details.

**TBD:** The Pb-Free/Green conversion plan has not been defined.

**Pb-Free (RoHS):** TI's terms "Lead-Free" or "Pb-Free" mean semiconductor products that are compatible with the current RoHS requirements for all 6 substances, including the requirement that lead not exceed 0.1% by weight in homogeneous materials. Where designed to be soldered at high temperatures, TI Pb-Free products are suitable for use in specified lead-free processes.

**Pb-Free (RoHS Exempt):** This component has a RoHS exemption for either 1) lead-based flip-chip solder bumps used between the die and package, or 2) lead-based die adhesive used between the die and leadframe. The component is otherwise considered Pb-Free (RoHS compatible) as defined above.

**Green (RoHS & no Sb/Br):** TI defines "Green" to mean Pb-Free (RoHS compatible), and free of Bromine (Br) and Antimony (Sb) based flame retardants (Br or Sb do not exceed 0.1% by weight in homogeneous material)

<sup>(3)</sup> MSL, Peak Temp. -- The Moisture Sensitivity Level rating according to the JEDEC industry standard classifications, and peak solder temperature.

**Important Information and Disclaimer:**The information provided on this page represents TI's knowledge and belief as of the date that it is provided. TI bases its knowledge and belief on information provided by third parties, and makes no representation or warranty as to the accuracy of such information. Efforts are underway to better integrate information from third parties. TI has taken and continues to take reasonable steps to provide representative and accurate information but may not have conducted destructive testing or chemical analysis on incoming materials and chemicals. TI and TI suppliers consider certain information to be proprietary, and thus CAS numbers and other limited information may not be available for release.

In no event shall TI's liability arising out of such information exceed the total purchase price of the TI part(s) at issue in this document sold by TI to Customer on an annual basis.

## IMPORTANT NOTICE

Texas Instruments Incorporated and its subsidiaries (TI) reserve the right to make corrections, modifications, enhancements, improvements, and other changes to its products and services at any time and to discontinue any product or service without notice. Customers should obtain the latest relevant information before placing orders and should verify that such information is current and complete. All products are sold subject to TI's terms and conditions of sale supplied at the time of order acknowledgment.

TI warrants performance of its hardware products to the specifications applicable at the time of sale in accordance with TI's standard warranty. Testing and other quality control techniques are used to the extent TI deems necessary to support this warranty. Except where mandated by government requirements, testing of all parameters of each product is not necessarily performed.

TI assumes no liability for applications assistance or customer product design. Customers are responsible for their products and applications using TI components. To minimize the risks associated with customer products and applications, customers should provide adequate design and operating safeguards.

TI does not warrant or represent that any license, either express or implied, is granted under any TI patent right, copyright, mask work right, or other TI intellectual property right relating to any combination, machine, or process in which TI products or services are used. Information published by TI regarding third-party products or services does not constitute a license from TI to use such products or services or a warranty or endorsement thereof. Use of such information may require a license from a third party under the patents or other intellectual property of the third party, or a license from TI under the patents or other intellectual property of TI.

Reproduction of TI information in TI data books or data sheets is permissible only if reproduction is without alteration and is accompanied by all associated warranties, conditions, limitations, and notices. Reproduction of this information with alteration is an unfair and deceptive business practice. TI is not responsible or liable for such altered documentation. Information of third parties may be subject to additional restrictions.

Resale of TI products or services with statements different from or beyond the parameters stated by TI for that product or service voids all express and any implied warranties for the associated TI product or service and is an unfair and deceptive business practice. TI is not responsible or liable for any such statements.

TI products are not authorized for use in safety-critical applications (such as life support) where a failure of the TI product would reasonably be expected to cause severe personal injury or death, unless officers of the parties have executed an agreement specifically governing such use. Buyers represent that they have all necessary expertise in the safety and regulatory ramifications of their applications, and acknowledge and agree that they are solely responsible for all legal, regulatory and safety-related requirements concerning their products and any use of TI products in such safety-critical applications, notwithstanding any applications-related information or support that may be provided by TI. Further, Buyers must fully indemnify TI and its representatives against any damages arising out of the use of TI products in such safety-critical applications.

TI products are neither designed nor intended for use in military/aerospace applications or environments unless the TI products are specifically designated by TI as military-grade or "enhanced plastic." Only products designated by TI as military-grade meet military specifications. Buyers acknowledge and agree that any such use of TI products which TI has not designated as military-grade is solely at the Buyer's risk, and that they are solely responsible for compliance with all legal and regulatory requirements in connection with such use.

TI products are neither designed nor intended for use in automotive applications or environments unless the specific TI products are designated by TI as compliant with ISO/TS 16949 requirements. Buyers acknowledge and agree that, if they use any non-designated products in automotive applications, TI will not be responsible for any failure to meet such requirements.

Following are URLs where you can obtain information on other Texas Instruments products and application solutions:

<b>Products</b>		<b>Applications</b>	
Amplifiers	<a href="http://amplifier.ti.com">amplifier.ti.com</a>	Audio	<a href="http://www.ti.com/audio">www.ti.com/audio</a>
Data Converters	<a href="http://dataconverter.ti.com">dataconverter.ti.com</a>	Automotive	<a href="http://www.ti.com/automotive">www.ti.com/automotive</a>
DSP	<a href="http://dsp.ti.com">dsp.ti.com</a>	Broadband	<a href="http://www.ti.com/broadband">www.ti.com/broadband</a>
Interface	<a href="http://interface.ti.com">interface.ti.com</a>	Digital Control	<a href="http://www.ti.com/digitalcontrol">www.ti.com/digitalcontrol</a>
Logic	<a href="http://logic.ti.com">logic.ti.com</a>	Military	<a href="http://www.ti.com/military">www.ti.com/military</a>
Power Mgmt	<a href="http://power.ti.com">power.ti.com</a>	Optical Networking	<a href="http://www.ti.com/opticalnetwork">www.ti.com/opticalnetwork</a>
Microcontrollers	<a href="http://microcontroller.ti.com">microcontroller.ti.com</a>	Security	<a href="http://www.ti.com/security">www.ti.com/security</a>
RFID	<a href="http://www.ti-rfid.com">www.ti-rfid.com</a>	Telephony	<a href="http://www.ti.com/telephony">www.ti.com/telephony</a>
Low Power Wireless	<a href="http://www.ti.com/lpw">www.ti.com/lpw</a>	Video & Imaging	<a href="http://www.ti.com/video">www.ti.com/video</a>
		Wireless	<a href="http://www.ti.com/wireless">www.ti.com/wireless</a>

Mailing Address: Texas Instruments, Post Office Box 655303, Dallas, Texas 75265  
Copyright © 2007, Texas Instruments Incorporated

## Looking for pricing, stock, or lifecycle information?

Click below to explore more details on WIN SOURCE:

 [View TLE2301INE](#) on WIN SOURCE

 [Texas Instruments](#) Information

## Optimize Your Supply Chain with WIN SOURCE Solutions

-  Global Sourcing Solution
-  Obsolete Management
-  Cost Control Management
-  Shortage Management
-  Alternative Solution
-  Excess Inventory Management