

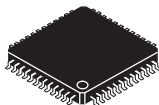

THE DATASHEET OF ADS7882IPFBT





12-BIT, 3-MSPS LOW POWER SAR ANALOG-TO-DIGITAL CONVERTER

FEATURES

- 3-MHz Sample Rate, 12-Bit Resolution
- Zero Latency
- Unipolar, Pseudo Differential Input, Range:
 - 0 V to 2.5 V
- High-Speed Parallel Interface
- 69.5 dB SNR at 100 kHz I/P
- Power Dissipation 85 mW at 3 MSPS
- Nap Mode (10 mW Power Dissipation)
- Power Down (10 μ W)
- Internal Reference
- Internal Reference Buffer
- 48-Pin TQFP Package

APPLICATIONS

- Optical Networking (DWDM, MEMS Based Switching)
- Spectrum Analyzers
- High Speed Data Acquisition Systems
- High Speed Close-Loop Systems
- Telecommunication
- Ultra-Sound Detection

DESCRIPTION

The ADS7882 is a 12-bit 3-MSPS A-to-D converter with 2.5-V internal reference. The device includes a capacitor based SAR A/D converter with inherent sample and hold. The device offers a 12-bit parallel interface with an additional byte mode that provides easy interface with 8-bit processors. The device has a pseudo-differential input stage.

The $-IN$ swing of ± 200 mV is useful to compensate for ground voltage mismatch between the ADC and sensor and also to cancel common-mode noise. With nap mode enabled, the device operates at lower power when used at lower conversion rates. The device is available in 48-pin TQFP package.

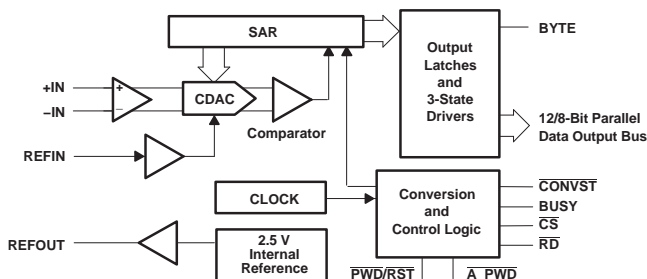

Please be aware that an important notice concerning availability, standard warranty, and use in critical applications of Texas Instruments semiconductor products and disclaimers thereto appears at the end of this data sheet.



This integrated circuit can be damaged by ESD. Texas Instruments recommends that all integrated circuits be handled with appropriate precautions. Failure to observe proper handling and installation procedures can cause damage.

ESD damage can range from subtle performance degradation to complete device failure. Precision integrated circuits may be more susceptible to damage because very small parametric changes could cause the device not to meet its published specifications.

ORDERING INFORMATION⁽¹⁾

MODEL	MAXIMUM INTEGRAL LINEARITY	MAXIMUM DIFFERENTIAL LINEARITY	NO MISSING CODES AT RESOLUTION (BIT)	PACKAGE TYPE	PACKAGE DESIGNATOR	TEMPERATURE RANGE	ORDERING INFORMATION	TRANSPORT MEDIA QUANTITY
ADS7882	±4 LSB at 12 bit	±4 LSB at 12 bit (±1 LSB at 10 bit)	10	48-Pin TQFP	PFB	–40°C to 85°C	ADS7882IPFBT	Tape and reel 250
							ADS7882IPFBR	Tape and reel 1000

(1) For the most current package and ordering information, see the Package Option Addendum at the end of this document, or see the TI website at www.ti.com.

ABSOLUTE MAXIMUM RATINGS

over operating free-air temperature range (unless otherwise noted) ⁽¹⁾

	VALUE	UNIT	
+IN to AGND	–0.3 to +VA + 0.1	V	
-IN to AGND	–0.3 to 0.5	V	
+VA to AGND	–0.3 to 7	V	
+VBD to BDGND	–0.3 to 7	V	
Digital input voltage to GND	–0.3 to (+VBD + 0.3 V)	V	
Digital output to GND	–0.3 to (+VBD + 0.3 V)	V	
Operating temperature range	–40 to 85	°C	
Storage temperature range	–65 to 150	°C	
Junction temperature (T _{J,max})	150	°C	
TQFP package	Power dissipation	(T _{J Max} –T _A)/ θ _{JA}	
	θ _{JA} Thermal impedance	86	°C/W
Lead temperature, soldering	Vapor phase (60 sec)	215	°C
	Infrared (15 sec)	220	°C

(1) Stresses beyond those listed under *absolute maximum ratings* may cause permanent damage to the device. These are stress ratings only, and functional operation of the device at these or any other conditions beyond those indicated under *recommended operating conditions* is not implied. Exposure to absolute-maximum-rated conditions for extended periods may affect device reliability.

SPECIFICATIONS
 $T_A = -40^{\circ}\text{C}$ to 85°C , $+V_A = 5\text{ V}$, $+V_{BD} = 5\text{ V}$ or 3.3 V , $V_{\text{ref}} = 2.5\text{ V}$, $f_{\text{sample}} = 3\text{ MHz}$ (unless otherwise noted)

PARAMETER	TEST CONDITIONS	MIN	TYP	MAX	UNIT
ANALOG INPUT					
Full-scale input span ⁽¹⁾	+IN – (–IN)	0		V_{ref}	V
Absolute input range	+IN	–0.2		$V_{\text{ref}} + 0.2$	V
	–IN	–0.2		0.2	
Input capacitance			27		pF
Input leakage current			500		pA
SYSTEM PERFORMANCE					
Resolution			12		Bits
No missing codes		10			Bits
Integral linearity ⁽²⁾		–4	± 1	4	LSB ⁽³⁾
Differential linearity		–4	± 1	4	LSB ⁽³⁾
Offset error ⁽⁴⁾			± 1		mV
Gain error ⁽⁴⁾			± 1.2		mV
Common-mode rejection ratio	With common mode input signal = 200 mV _{p-p} at 1 MHz		60		dB
Power supply rejection	At FF0 _H output code, $+V_A = 4.75\text{ V}$ to 5.25 V , $V_{\text{ref}} = 2.50\text{ V}$		80		dB
SAMPLING DYNAMICS					
Conversion time	+V _{DB} = 5 V			280	nsec
	+V _{DB} = 3 V			280	
Acquisition time	+V _{DB} = 5 V	53			nsec
	+V _{DB} = 3 V	53			
Maximum throughput rate				3	MHz
Aperture delay			2		nsec
Aperture jitter			20		psec
Step response			50		nsec
Overvoltage recovery			50		nsec
DYNAMIC CHARACTERISTICS					
Total harmonic distortion ⁽⁵⁾	$V_{\text{IN}} = 2.496\text{ V}_{\text{p-p}}$ at 0.1 MHz/2.5 V_{ref}		–79.5		dB
SNR	$V_{\text{IN}} = 2.496\text{ V}_{\text{p-p}}$ at 0.1 MHz/2.5 V_{ref}		69.5		dB
SINAD	$V_{\text{IN}} = 2.496\text{ V}_{\text{p-p}}$ at 0.1 MHz/2.5 V_{ref}		68.5		dB
SFDR	$V_{\text{IN}} = 2.496\text{ V}_{\text{p-p}}$ at 0.1 MHz/2.5 V_{ref}		80.5		dB
–3 dB Small signal bandwidth			50		MHz
EXTERNAL REFERENCE INPUT					
Input V_{REF} range		2.4	2.5	2.6	V
Resistance ⁽⁶⁾			500		k Ω
INTERNAL REFERENCE OUTPUT					
Start-up time	From 95% (+V _A), with 1- μ F storage capacitor on REFO _{UT} to AGND			120	msec
V_{REF} range	IO _{UT} = 0	2.425	2.5	2.575	V
Source current	Static load			10	μ A
Line regulation	$+V_A = 4.75\text{ V}$ to 5.25 V		1		mV
Drift	IO _{UT} = 0		25		PPM/ $^{\circ}\text{C}$

- (1) Ideal input span; does not include gain or offset error.
- (2) This is endpoint INL, not best fit.
- (3) LSB means least significant bit.
- (4) Measured relative to actual measured reference.
- (5) Calculated on the first nine harmonics of the input frequency.
- (6) Can vary $\pm 20\%$.

SPECIFICATIONS (continued)

T_A = -40°C to 85°C, +VA = 5 V, +VBD = 5 V or 3.3 V, V_{ref} = 2.5 V, f_{sample} = 3 MHz (unless otherwise noted)

PARAMETER		TEST CONDITIONS	MIN	TYP	MAX	UNIT
DIGITAL INPUT/OUTPUT						
Logic family			CMOS			
Logic level	V _{IH}	I _{IH} = 5 μA	+V _{BD} -1	+V _{BD} +0.3		V
	V _{IL}	I _{IL} = 5 μA	-3		0.8	V
	V _{OH}	I _{OH} = 2 TTL loads	+V _{BD} -0.6		+V _{BD}	V
	V _{OL}	I _{OL} = 2 TTL loads	0		0.4	V
Data format			Straight Binary			
POWER SUPPLY REQUIREMENTS						
Power supply voltage	+VBD		2.7	3.3	5.25	V
	+VA		4.75	5	5.25	V
Supply current, +VA, 3 MHz sample rate				17	22	mA
Power dissipation, 3 MHz sample rate		+VA = 5 V		85	110	mW
NAP MODE						
Supply current, +VA				2	3	mA
Power-up time ⁽⁷⁾				60		nsec
POWER DOWN						
Supply current, +VA				2	2.5	μA
Power down time ⁽⁸⁾		From simulation results		10		μsec
Power up time		1-μF storage capacitor on REFOUT to AGND		25		msec
Invalid conversions after power up or reset						
TEMPERATURE RANGE						
Operating free-air			-40		85	°C

(7) Minimum acquisition time for first sampling after the end of nap state must be 60 nsec more than normal.

(8) Time required to reach level of 2.5 μA.

TIMING REQUIREMENTS

 All specifications typical at -40°C to 85°C , $+V_A = +5\text{ V}$, $+V_{BD} = +5\text{ V}$ ⁽¹⁾ ⁽²⁾ ⁽³⁾ ⁽⁴⁾

PARAMETER		MIN	TYP	MAX	UNIT	REF FIG.
$t_{(\text{conv})}$	Conversion time			280	ns	5
$t_{(\text{acq})}$	Acquisition time	53			ns	5
SAMPLING AND CONVERSION START						
t_{h1}	Hold time $\overline{\text{CS}}$ low to $\overline{\text{CONVST}}$ high (with BUSY high)	10			ns	3
t_{d1}	Delay $\overline{\text{CONVST}}$ high to acquisition start	2	4	5	ns	1
t_{h2}	Hold time, $\overline{\text{CONVST}}$ high to $\overline{\text{CS}}$ high with BUSY low	10			ns	1
t_{h3}	Hold time, $\overline{\text{CONVST}}$ low to $\overline{\text{CS}}$ high	10			ns	1
t_{d2}	Delay $\overline{\text{CONVST}}$ low to BUSY high			40	ns	1
t_{w3}	$\overline{\text{CS}}$ width for acquisition or conversion to start	20			ns	2
t_{d3}	Delay $\overline{\text{CS}}$ low to acquisition start with $\overline{\text{CONVST}}$ high	2	4	5	ns	2
t_{w1}	Pulse width, from $\overline{\text{CS}}$ low to $\overline{\text{CONVST}}$ low for acquisition to start	20			ns	2
t_{d4}	Delay $\overline{\text{CS}}$ low to BUSY high with $\overline{\text{CONVST}}$ low			40	ns	2
	Quiet sampling time ⁽³⁾	25			ns	
CONVERSION ABORT						
t_{s1}	Setup time $\overline{\text{CONVST}}$ high to $\overline{\text{CS}}$ low with BUSY high			15	ns	4
t_{d5}	Delay time $\overline{\text{CS}}$ low to BUSY low with $\overline{\text{CONVST}}$ high			20	ns	4
DATA READ						
t_{d6}	Delay $\overline{\text{RD}}$ low to data valid with $\overline{\text{CS}}$ low			25	ns	
t_{d7}	Delay BYTE high to LSB word valid with $\overline{\text{CS}}$ and $\overline{\text{RD}}$ low			25	ns	5
t_{d9}	Delay time $\overline{\text{RD}}$ high to data 3-state with $\overline{\text{CS}}$ low			25	ns	5
t_{d11}	Delay time end of conversion to BUSY low			20	ns	5
t_1	Quiet sampling time $\overline{\text{RD}}$ high to $\overline{\text{CONVST}}$ low			20	ns	5
t_{d8}	Delay $\overline{\text{CS}}$ low to data valid with $\overline{\text{RD}}$ low			25	ns	5
t_{d10}	Delay $\overline{\text{CS}}$ high to data 3-state with $\overline{\text{RD}}$ low			25	ns	6
t_2	Quiet sampling time $\overline{\text{CS}}$ low to $\overline{\text{CONVST}}$ low			25	ns	6
BACK-TO-BACK CONVERSION						
t_{d12}	Delay BUSY low to data valid			10	ns	7, 8
t_{w4}	Pulse width, $\overline{\text{CONVST}}$ high	63			ns	7, 8
t_{w5}	Pulse width, $\overline{\text{CONVST}}$ low	20			ns	7
POWER DOWN/RESET						
t_{w6}	Pulse width, low for $\overline{\text{PWD/RST}}$ to reset the device	45		6140	ns	10
t_{w7}	Pulse width, low for $\overline{\text{PWD/RST}}$ to power down the device	7200			ns	9
t_{d13}	Delay time, power up after $\overline{\text{PWD/RST}}$ is high			25	ns	9

(1) All input signals are specified with $t_r = t_f = 5\text{ ns}$ (10% to 90% of $+V_{BD}$) and timed from a voltage level of $(V_{IL} + V_{IH})/2$.

(2) See timing diagram.

(3) Quiet period before conversion start, no data bus activity including data bus 3-state is allowed in this period.

(4) All timings are measured with 20 pF equivalent loads on all data bits and BUSY pin.

PIN ASSIGNMENTS

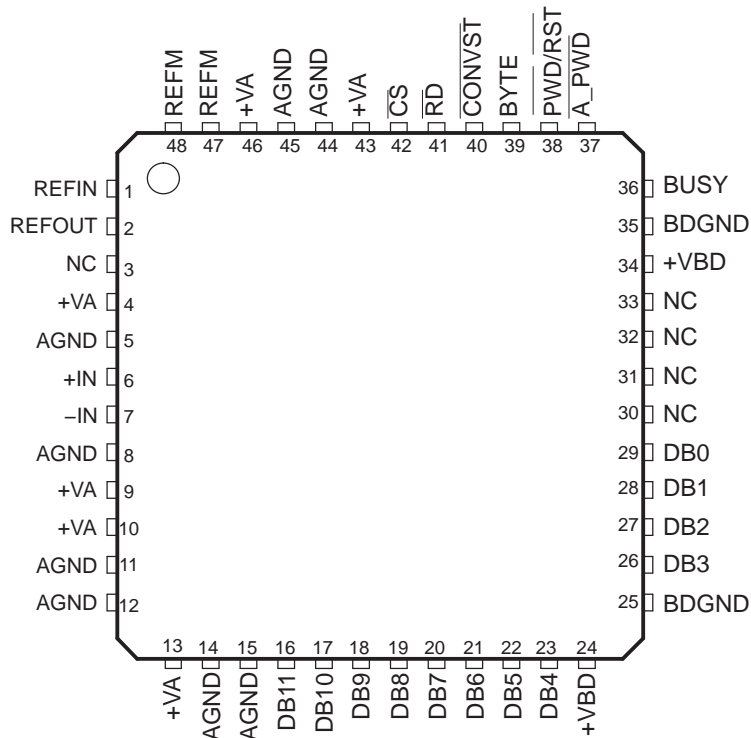

NC – No connection

PIN FUNCTIONS

PIN		I/O	DESCRIPTION		
NAME	NO. PFB		8-BIT BUS		16-BIT BUS
DATA BUS			BYTE = 0	BYTE = 1	BYTE = 0
DB11	16	O	D11 (MSB)	D3	D11 (MSB)
DB10	17	O	D10	D2	D10
DB9	18	O	D9	D1	D9
DB8	19	O	D8	D0 (LSB)	D8
DB7	20	O	D7	0	D7
DB6	21	O	D6	0	D6
DB5	22	O	D5	0	D5
DB4	23	O	D4	0	D4
DB3	26	O	D3	0	D3
DB2	27	O	D2	0	D2
DB1	28	O	D1	0	D1
DB0	29	O	D0 (LSB)	0	D0 (LSB)
CONTROL PINS					
$\overline{\text{CS}}$	42	I	Chip select. Active low signal enables chip operation like acquisition start, conversion start, bus release from 3-state. Refer to the timing diagrams for more details.		
$\overline{\text{CONVST}}$	40	I	Conversion start. The rising edge starts the acquisition. The falling edge of this input ends the acquisition and starts the conversion. Refer to the timing diagrams for more details.		
$\overline{\text{RD}}$	41	I	Active low synchronization pulse for the parallel output. When $\overline{\text{CS}}$ is low, this serves as the output enable and puts the previous conversion results on the bus.		
$\overline{\text{A_PWD}}$	37	I	Nap mode enable, active low		

PIN FUNCTIONS (continued)

PIN		I/O	DESCRIPTION		
NAME	NO. PFB				
DATA BUS			8-BIT BUS		16-BIT BUS
			BYTE = 0	BYTE = 1	BYTE = 0
PWD/RST	38	I	Active low input, acts as device power down/device reset signal.		
BYTE	39	I	Byte select input. Used for 8-bit bus reading. 0: No fold back 1: Lower byte D[3:0] is folded back to high byte so D3 is available in D11 place.		
STATUS OUTPUT					
BUSY	36	O	Status output. High when a conversion is in progress.		
POWER SUPPLY					
+VBD	24, 34	–	Digital power supply for all digital inputs and outputs. Refer to Table 3 for layout guidelines.		
BDGND	25, 35	–	Digital ground for all digital inputs and outputs. Short to analog ground plane below the device.		
+VA	4, 9, 10, 13, 43, 46	–	Analog power supplies. Refer to Table 3 for layout guidelines.		
AGND	5, 8, 11, 12, 14, 15, 44, 45	–	Analog ground pins. Short to analog ground plane below the device.		
ANALOG INPUT					
+IN	6	I	Noninverting analog input channel		
–IN	7	I	Inverting analog input channel		
REFIN	1	I	Reference (positive) input. Needs to be decoupled with REFM pin using 0.1- μ F bypass capacitor and 1- μ F storage capacitor.		
REFOUT	2	O	Internal reference output. To be shorted to REFIN pin when internal reference is used. Do not connect to REFIN pin when external reference is used. Always needs to be decoupled with AGND using 0.1- μ F bypass capacitor.		
REFM	47, 48	I	Reference ground. Connect to analog ground plane.		
NC		–	No connection		

DESCRIPTION AND TIMING DIAGRAMS

SAMPLING AND CONVERSION START

There are three ways to start sampling. The rising edge of $\overline{\text{CONVST}}$ starts sampling with $\overline{\text{CS}}$ and BUSY being low (see Figure 1) or it can be started with the falling edge of CS when CONVST is high and BUSY is low (see Figure 2). Sampling can also be started with an internal conversion end (before BUSY falling edge) with $\overline{\text{CS}}$ being low and $\overline{\text{CONVST}}$ high before an internal conversion end (see Figure 3). Also refer to the section DEVICE OPERATION AND DATA READ IN BACK-TO-BACK CONVERSION for more details.

A conversion can be started two ways (a conversion start is the end of sampling). Either with the falling edge of $\overline{\text{CONVST}}$ when $\overline{\text{CS}}$ is low (see Figure 1) or the falling edge of CS when $\overline{\text{CONVST}}$ is low (see Figure 2). A clean and low jitter falling edge of these respective signals triggers a conversion start and is important to the performance of the converter. The BUSY pin is brought high immediately following the $\overline{\text{CONVST}}$ falling edge. BUSY stays high throughout the conversion process and returns low when the conversion has ended.

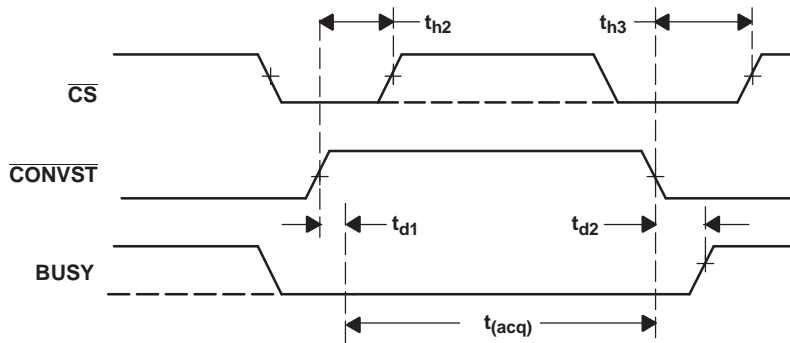

Figure 1. Sampling and Conversion Start Control With $\overline{\text{CONVST}}$ Pin

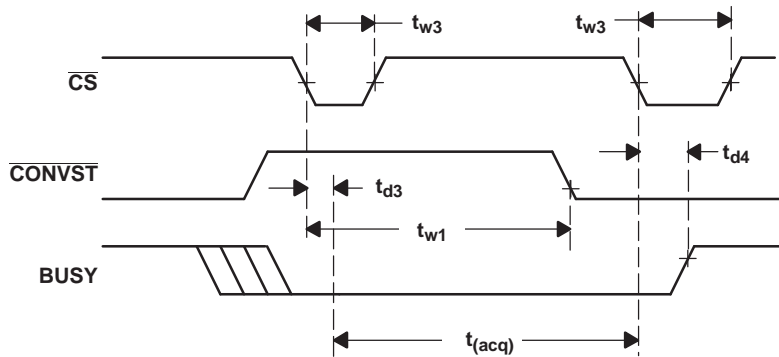

Figure 2. Sampling and Conversion Start Control With $\overline{\text{CS}}$ Pin

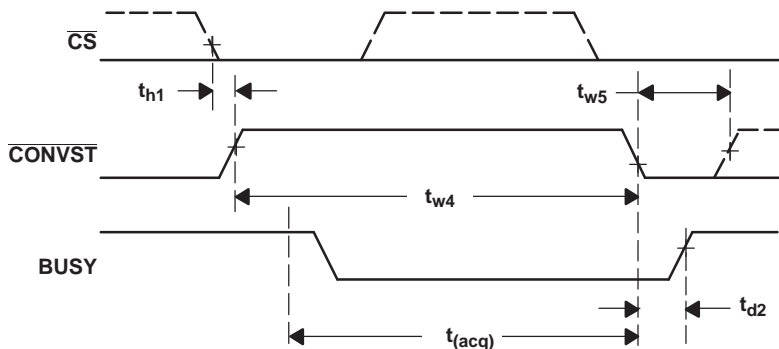

Figure 3. Sampling Start With $\overline{\text{CS}}$ Low and $\overline{\text{CONVST}}$ High (Back-to-Back)

CONVERSION ABORT

The falling edge of \overline{CS} aborts the conversion while BUSY is high and \overline{CONVST} is high (see Figure 4). The device outputs FE0 (hex) to indicate a conversion abort.

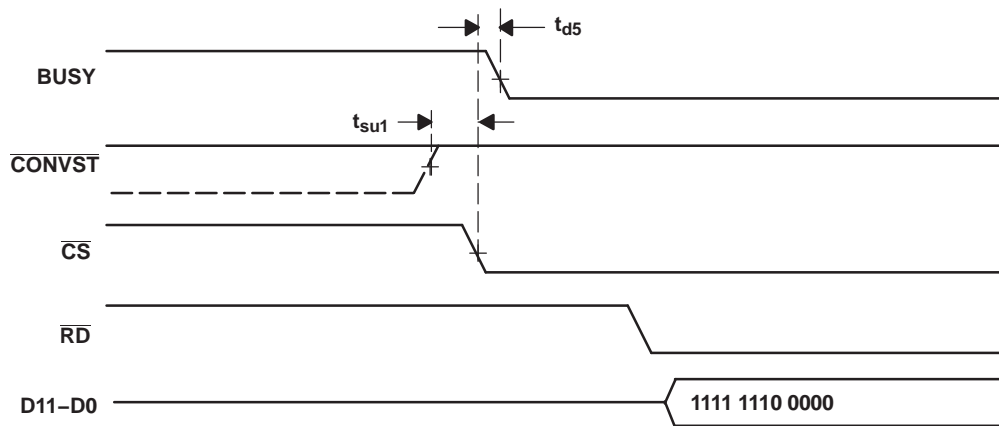

Figure 4. Conversion Abort

DATA READ

Two conditions need to be satisfied for a read operation. Data appears on the D11 through D0 pins (with D11 MSB) when both \overline{CS} and \overline{RD} are low. Figure 5 and Figure 6 illustrate the device read operation. The bus is 3-stated if any one of the signals is high.

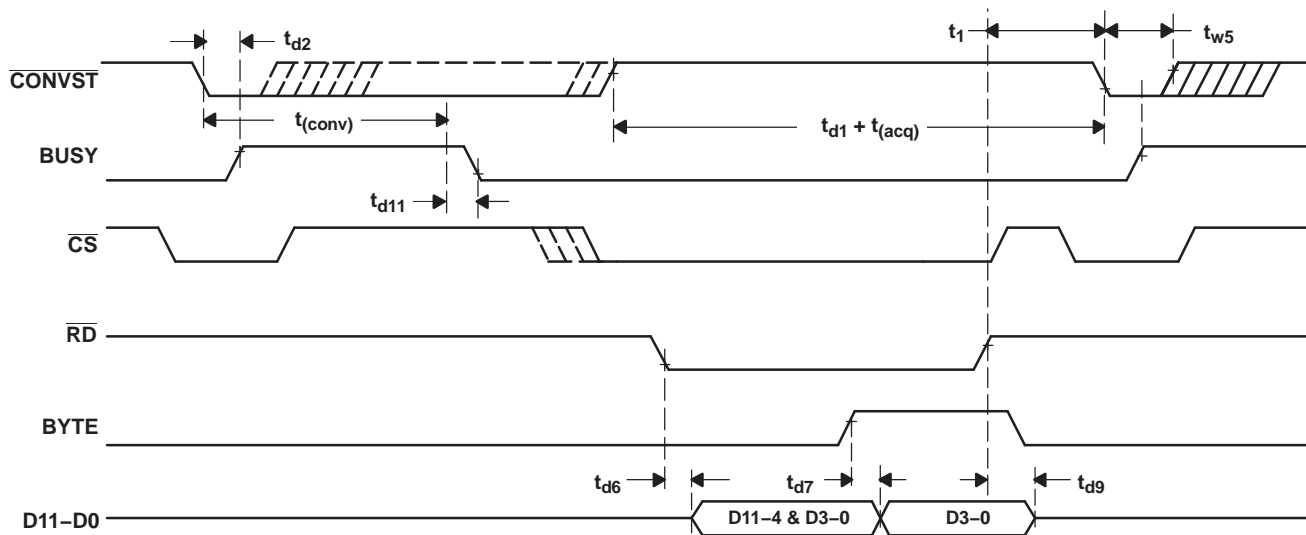

Figure 5. Read Control via \overline{CS} and \overline{RD}

There are two output formats available. Twelve bit data appears on the bus during a read operation while \overline{BYTE} is low. When \overline{BYTE} is high, the lower byte (D3 through D0 followed by all zeroes) appears on the data bus with D3 in the MSB. This feature is useful for interfacing with eight bit microprocessors and microcontrollers.

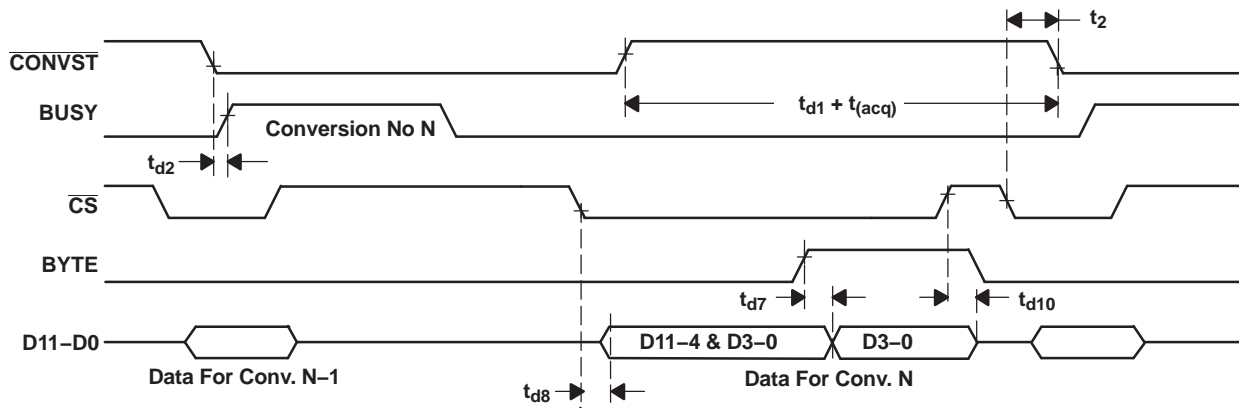

Figure 6. Read Control Via \overline{CS} and \overline{RD} Tied to BDGND

DEVICE OPERATION AND DATA READ IN BACK-TO-BACK CONVERSION

Figure 7 and Figure 8 illustrate device operation in back-to-back conversion mode. It is possible to operate the device at any throughput in this mode, but this is the only mode in which the device can be operated at throughputs exceeding 2.83 MSPS ($1/t_{(acq)} \text{ min} + t_{(conv)} \text{ max} + t_{d11} \text{ max}$).

A conversion starts on the \overline{CONVST} falling edge. The BUSY output goes high after a delay (t_{d2}). Note that care must be taken not to abort the conversion (see Figure 4) apart from timing restrictions shown in Figure 7 and Figure 8. The conversion ends within the conversion time, $t_{(conv)}$, after the \overline{CONVST} falling edge. The new acquisition can be immediately started without waiting for the BUSY signal to go low. This can be ensured with a \overline{CONVST} high pulse width that is more than or equal to $(t_0 - t_{(conv)} + 10 \text{ nsec})$ which is t_{w4} for a 3-MHz operation.

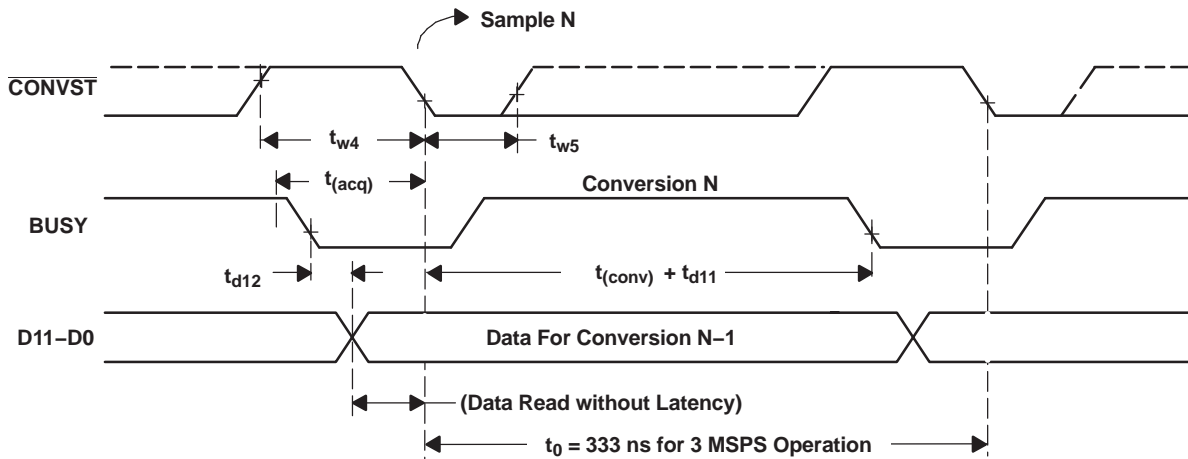

Figure 7. Back-To-Back Operation With \overline{CS} and \overline{RD} Low

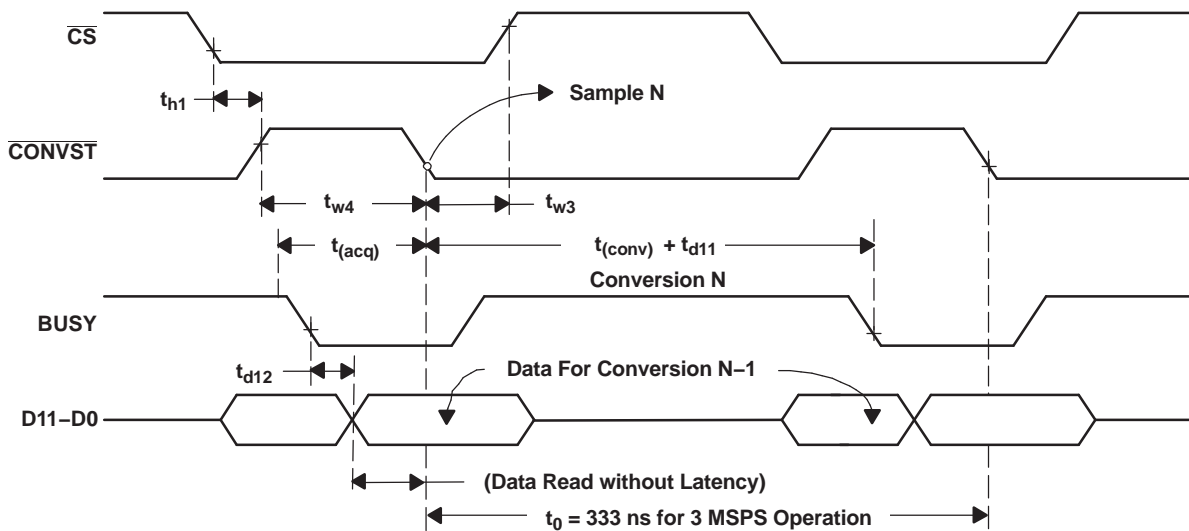

Figure 8. Back-To-Back operation With \overline{CS} Toggling and \overline{RD} Low

NAP MODE

The device can be put in nap mode following the sequences shown in Figure 9. This provides substantial power saving while operating at lower sampling rates.

While operating the device at throughput rates lower than 2.54 MSPS, $\overline{A_PWD}$ can be held low (see Figure 9). In this condition, the device goes into the nap state immediately after $BUSY$ goes low and remains in that state until the next sampling starts. The minimum acquisition time is 60 nsec more than $t_{(acq)}$ as defined in the timing requirements section.

Alternately, $\overline{A_PWD}$ can be toggled any time during operation (see Figure 10). This is useful when the system acquires data at the maximum conversion speed for some period of time (back-to-back conversion) and it does not acquire data for some time while the acquired data is being processed. During this period, the device can be put in the nap state to save power. The device remains in the nap state as long as $\overline{A_PWD}$ is low with $BUSY$ being low and sampling has not started. The minimum acquisition time for the first sampling after the nap state is 60 nsec more than $t_{(acq)}$ as defined in the timing requirements section.

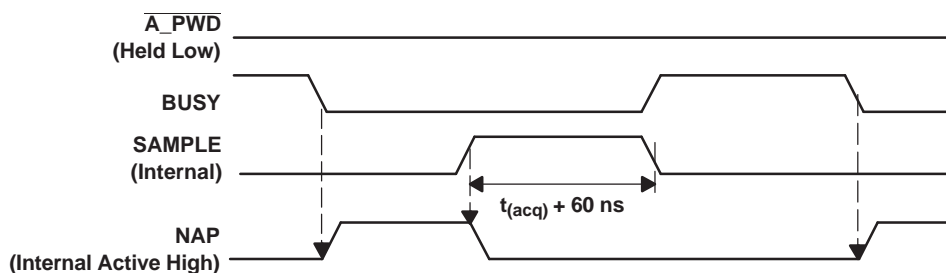

NOTE: The SAMPLE (Internal) signal is generated as described in the Sampling and Conversion Start section.

Figure 9. Device Operation While $\overline{A_PWD}$ is Held Low

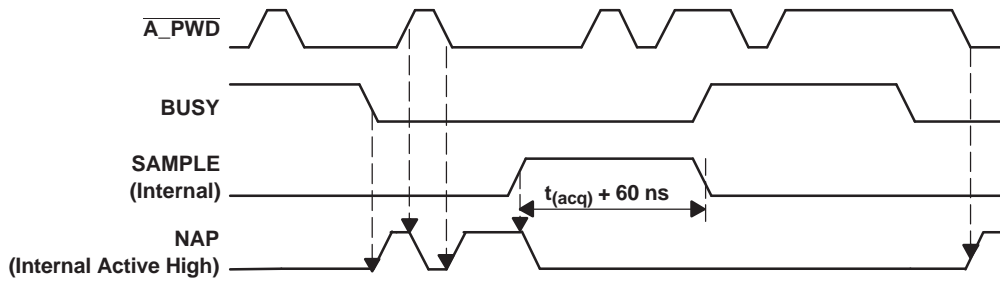

NOTE: The SAMPLE (Internal) signal is generated as described in the Sampling and Conversion Start section.

Figure 10. Device Operation While $\overline{\text{A_PWD}}$ is Toggling

POWERDOWN/RESET

A low level on the $\overline{\text{PWD/RST}}$ pin puts the device in the powerdown phase. This is an asynchronous signal. As shown in Figure 11, the device is in the reset phase for the first t_{w6} period after a high-to-low transition of $\overline{\text{PWD/RST}}$. During this period the output code is FE0 (hex) to indicate that the device is in the reset phase. The device powers down if the $\overline{\text{PWD/RST}}$ pin continues to be low for a period of more than t_{w7} . Data is not valid for the first four conversions after a power-up (see Figure 11) or an end of reset (see Figure 12). The device is initialized during the first four conversions.

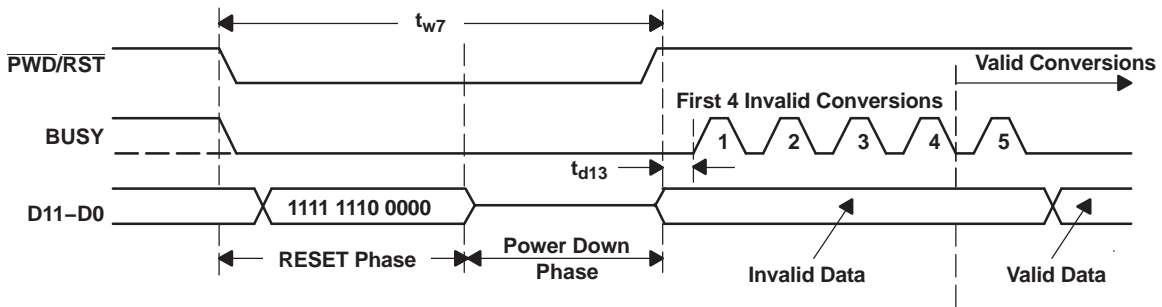

Figure 11. Device Power Down

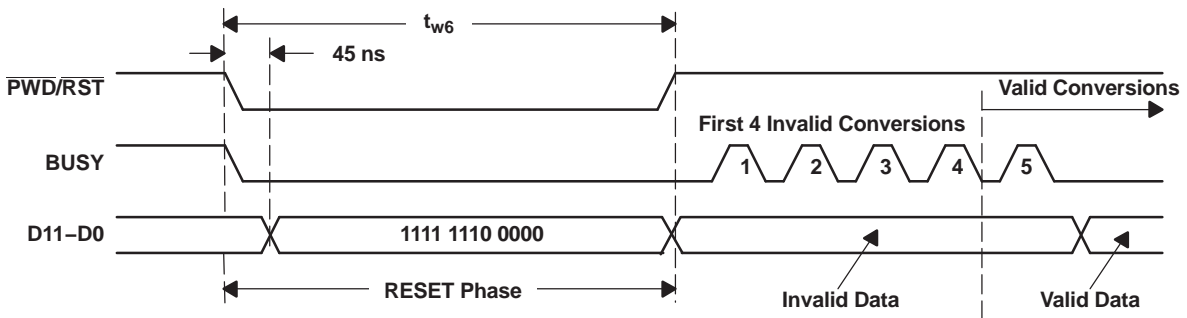

Figure 12. Device Reset

TYPICAL CHARACTERISTICS (1)

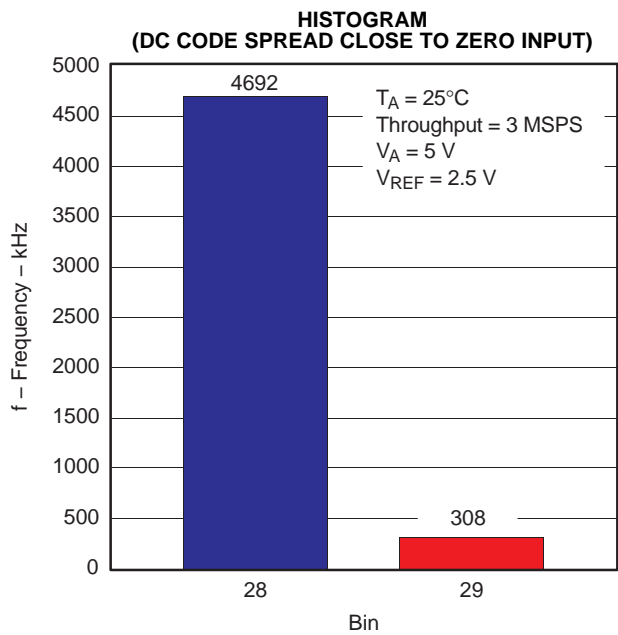

Figure 13.

G001

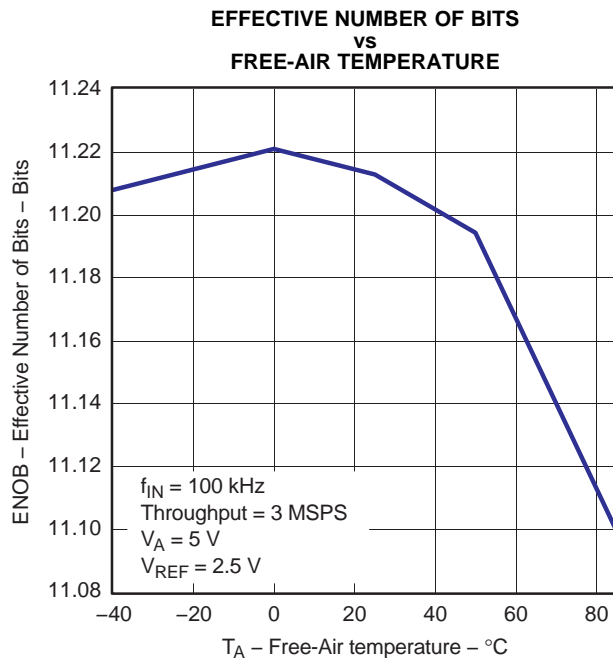

Figure 14.

G002

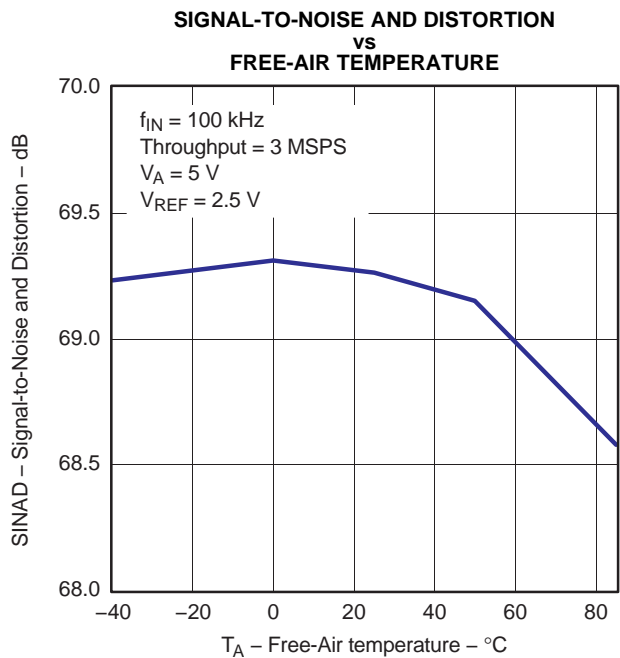

Figure 15.

G003

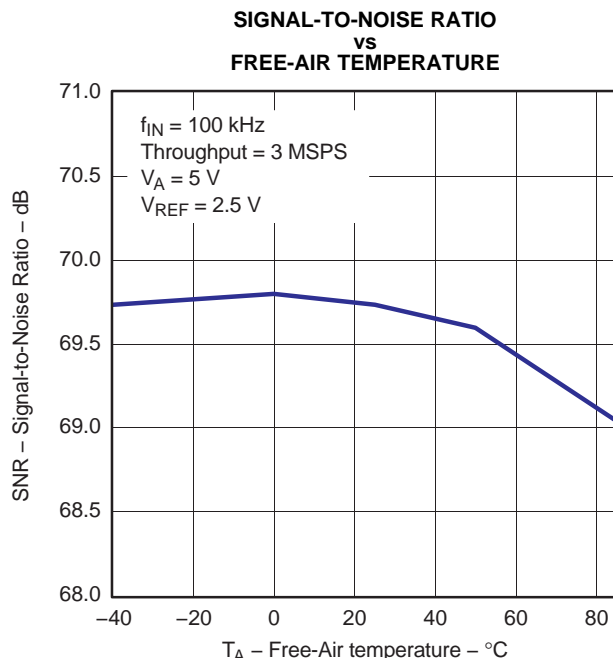

Figure 16.

G004

(1) At sample rate = 3 MSPS, $V_{ref} = 2.5\text{ V}$ external, unless otherwise specified.

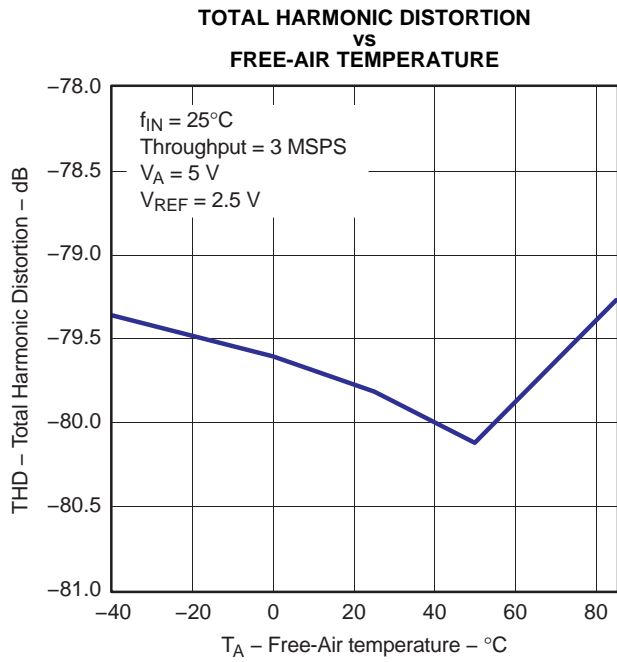

Figure 17.

G005

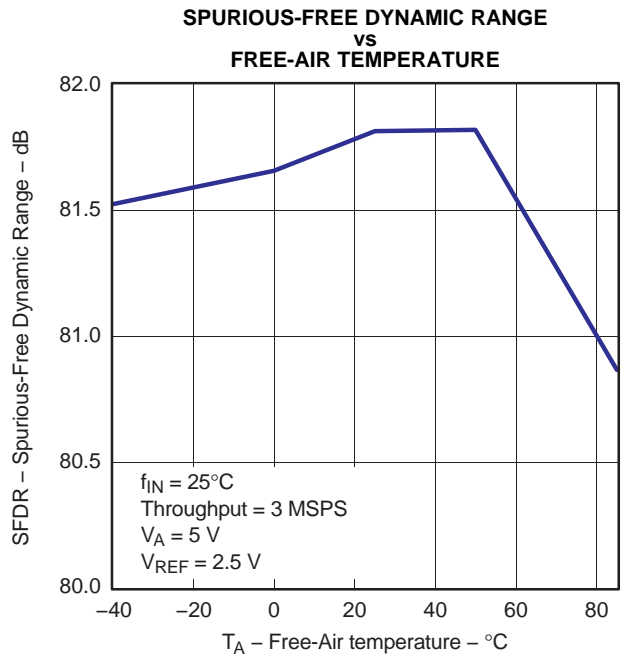

Figure 18.

G006

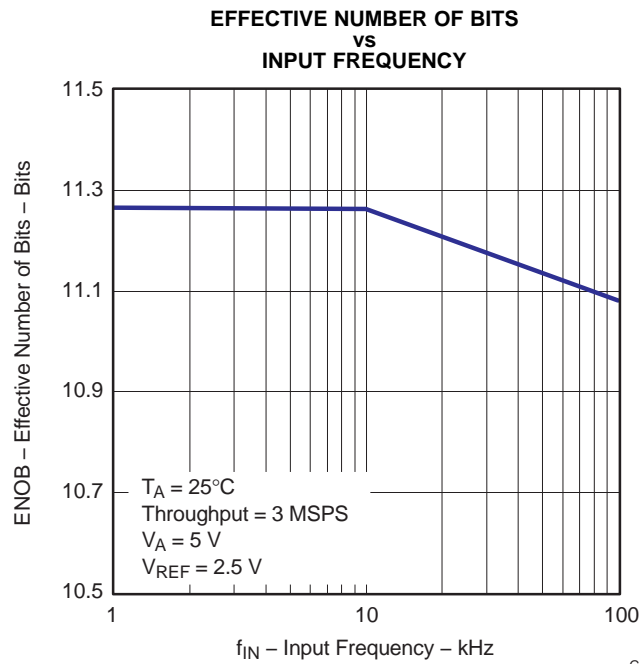

Figure 19.

G007

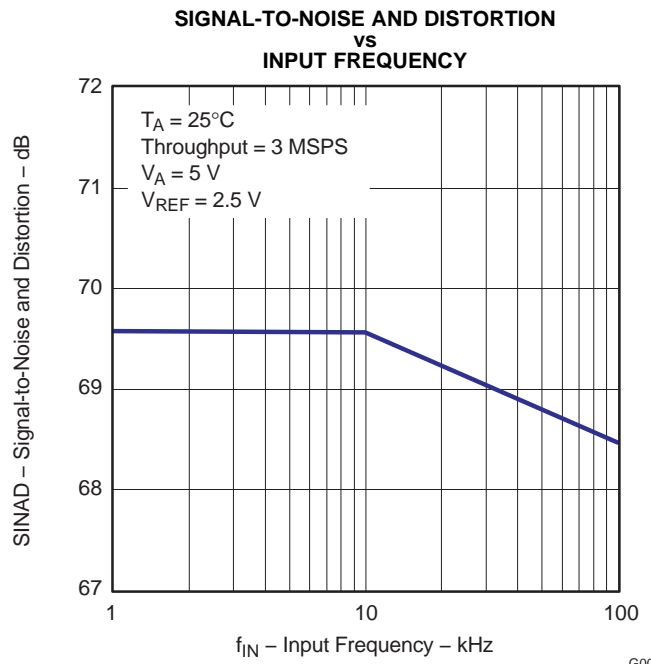

Figure 20.

G008

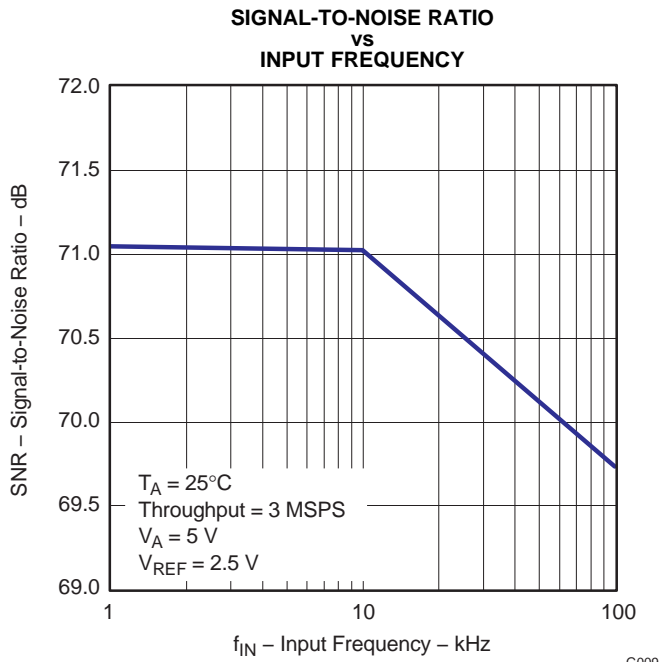

Figure 21.

G009

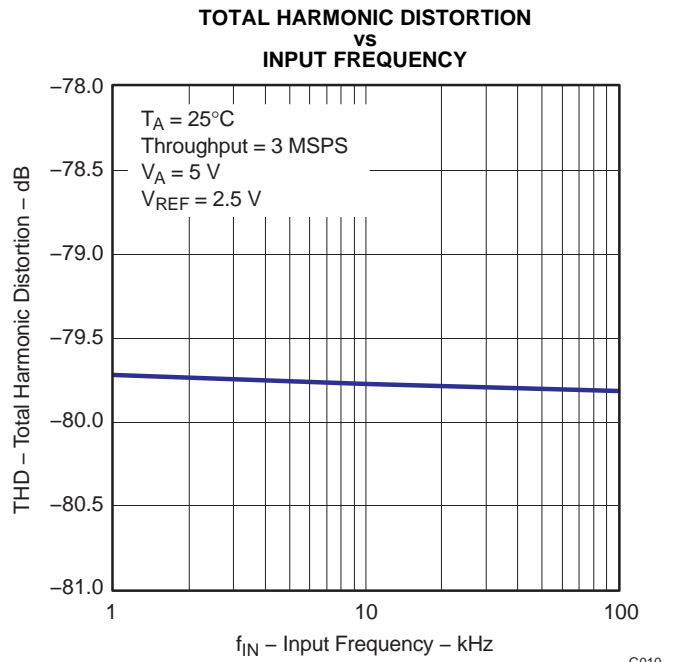

Figure 22.

G010

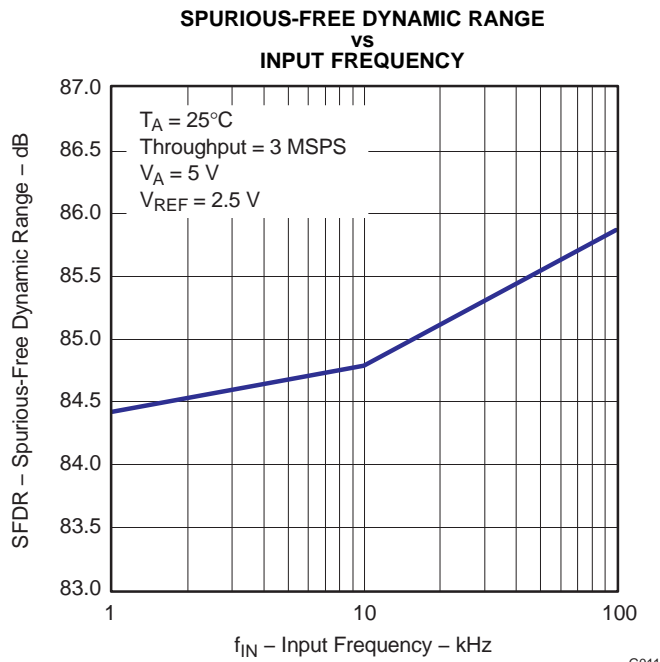

Figure 23.

G011

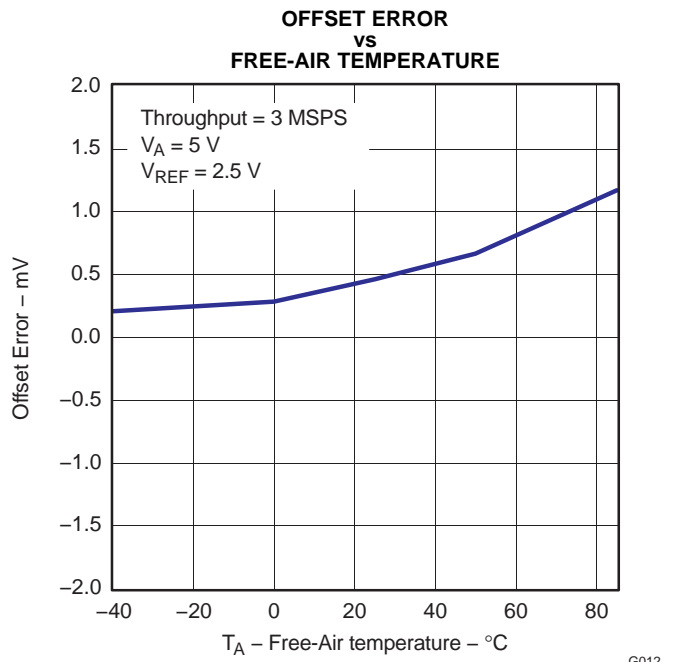
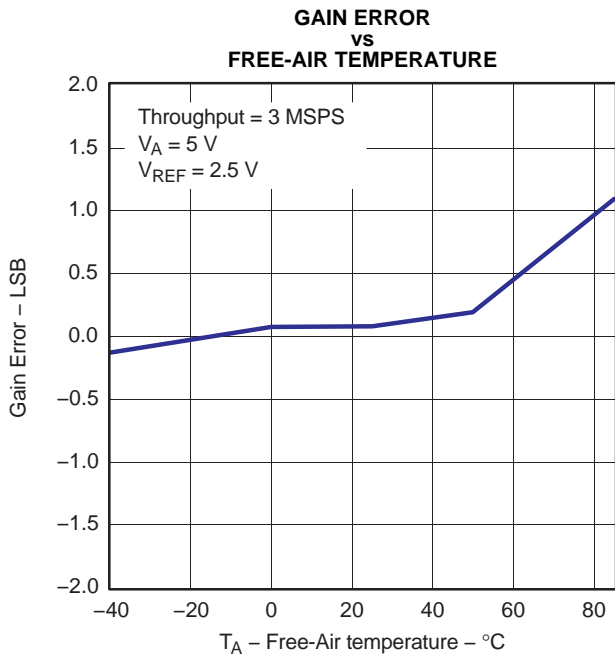

Figure 24.

G012



G013

Figure 25.

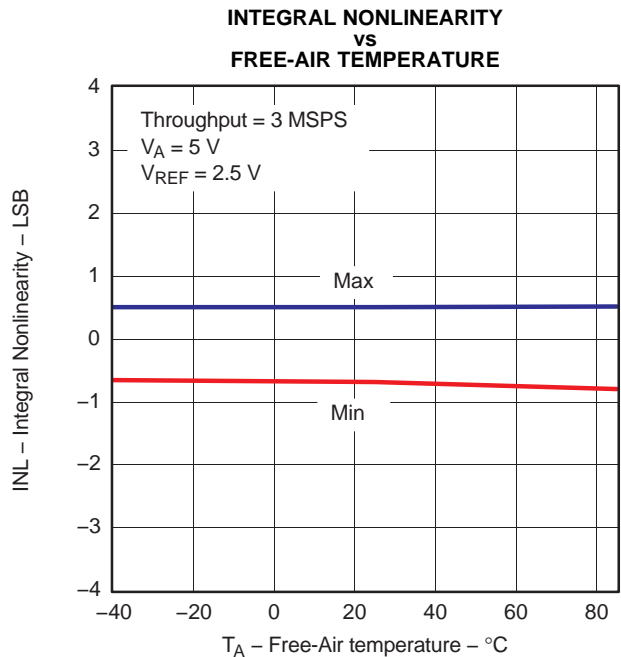

G014

Figure 26.

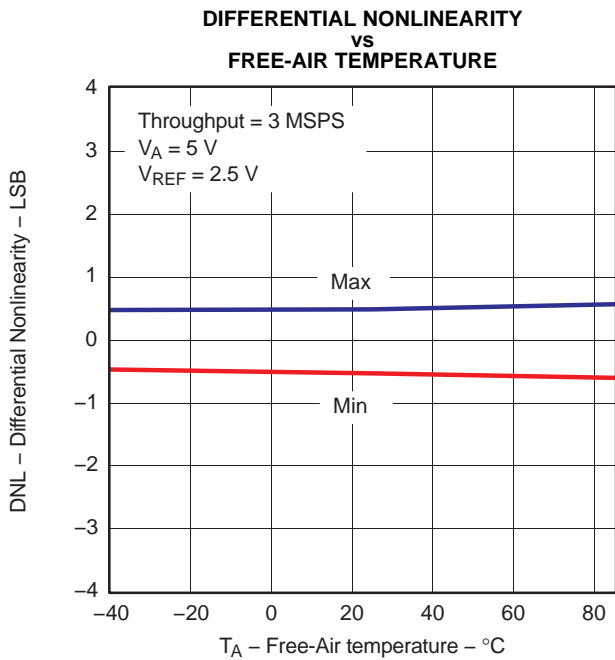

G015

Figure 27.

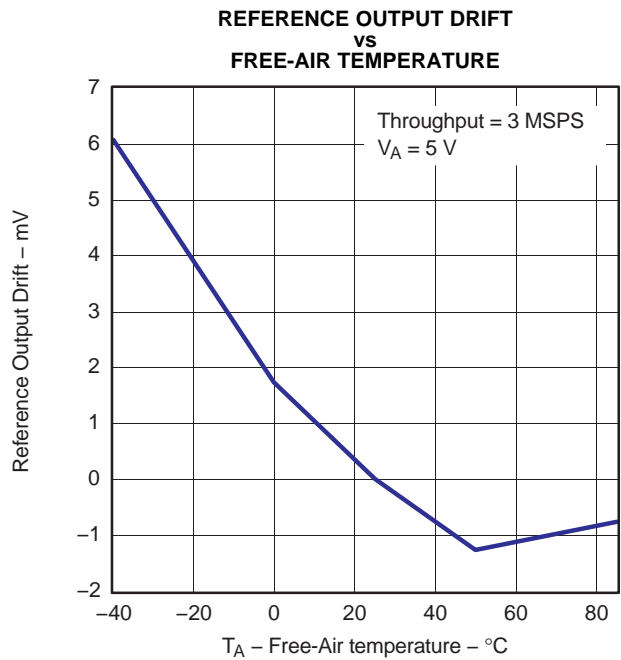

G016

Figure 28.

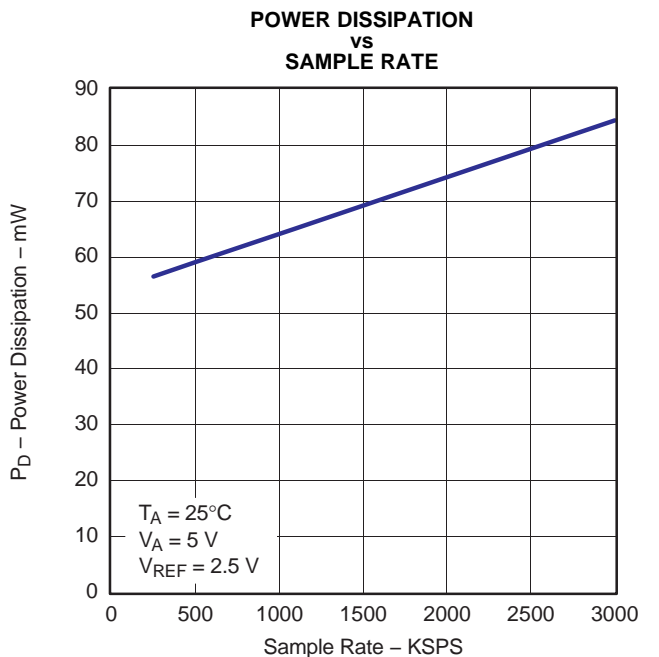

Figure 29.
DIFFERENTIAL NONLINEARITY

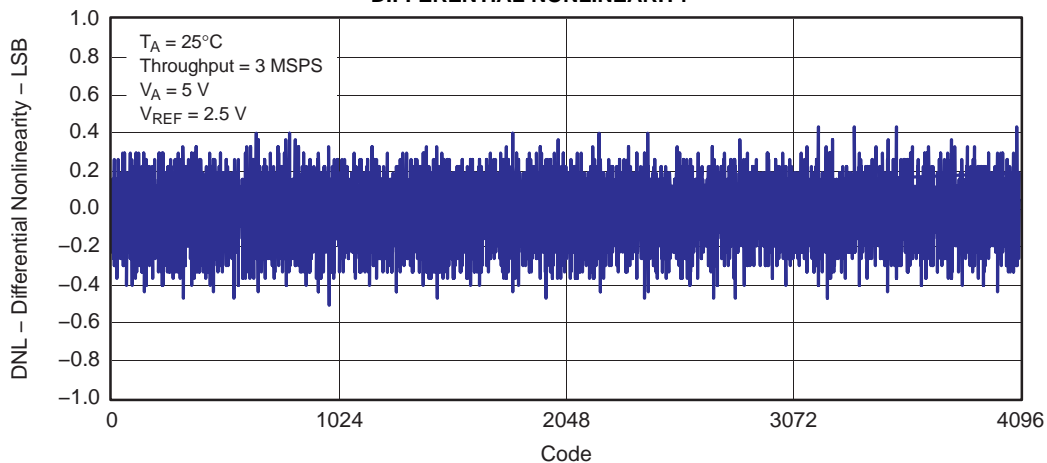

Figure 30.

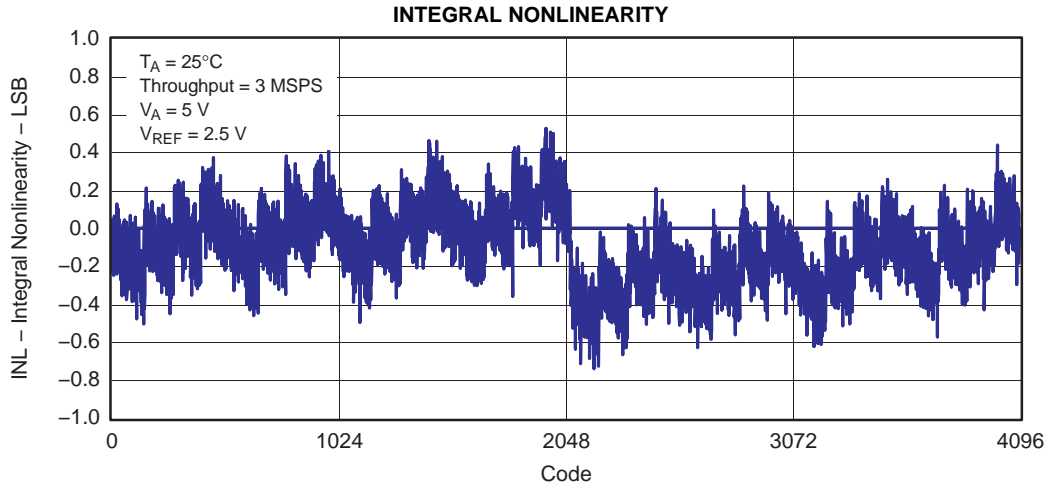

Figure 31.

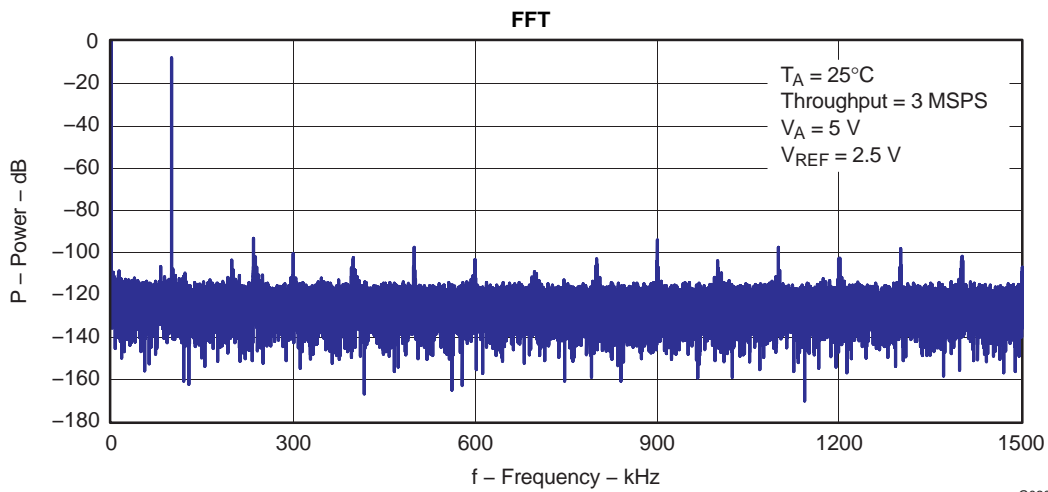

Figure 32.

PRINCIPLES OF OPERATION

The ADS7882 is a member of a family of high-speed successive approximation register (SAR) analog-to-digital converters (ADC). The architecture is based on charge redistribution, which inherently includes a sample/hold function.

The conversion clock is generated internally. The conversion time is 200 ns max (at 5 V +VBD).

The analog input is provided to two input pins: +IN and –IN. (Note that this is pseudo differential input and there are restrictions on –IN voltage range.) When a conversion is initiated, the difference voltage between these pins is sampled on the internal capacitor array. While a conversion is in progress, both inputs are disconnected from any internal function.

REFERENCE

The ADS7882 has a built-in 2.5-V (nominal value) reference but can operate with an external reference. When an internal reference is used, pin 2 (REFOUT) should be connected to pin 1 (REFIN) with an 0.1- μF decoupling capacitor and a 1- μF storage capacitor between pin 2 (REFOUT) and pins 47, 48 (REFM). The internal reference of the converter is buffered. There is also a buffer from REFIN to CDAC. This buffer provides isolation between the external reference and the CDAC and also recharges the CDAC during conversion. It is essential to decouple REFOUT to AGND with a 0.1- μF capacitor while the device operates with an external reference.

PRINCIPLES OF OPERATION (continued)

ANALOG INPUT

When the converter enters hold mode, the voltage difference between the +IN and -IN inputs is captured on the internal capacitor array. The voltage on the -IN input is limited to between -0.2 V and 0.2 V, thus allowing the input to reject a small signal which is common to both the +IN and -IN inputs. The +IN input has a range of -0.2 V to (+V_{ref} +0.2 V). The input span (+IN - (-IN)) is limited from 0 V to V_{REF}.

The input current on the analog inputs depends upon a number of factors: sample rate, input voltage, signal frequency, and source impedance. Essentially, the current into the ADS7882 charges the internal capacitor array during the sample period. After this capacitance has been fully charged, there is no further input current (this may not happen when a signal is moving continuously). The source of the analog input voltage must be able to charge the input capacitance (27 pF) to better than a 12-bit settling level with a step input within the acquisition time of the device. The step size can be selected equal to the maximum voltage difference between two consecutive samples at the maximum signal frequency. (Refer to [Figure 35](#) for the suggested input circuit.) When the converter goes into hold mode, the input impedance is greater than 1 GΩ.

Care must be taken regarding the absolute analog input voltage. To maintain the linearity of the converter, both -IN and +IN inputs should be within the limits specified. Outside of these ranges, the converter's linearity may not meet specifications.

Care should be taken to ensure that +IN and -IN see the same impedance to the respective sources. (For example, both +IN and -IN are connected to a decoupling capacitor through a 21-Ω resistor as shown in [Figure 35](#).) If this is not observed, the two inputs could have different settling times. This may result in an offset error, gain error, or linearity error which changes with temperature and input voltage.

DIGITAL INTERFACE

TIMING AND CONTROL

Refer to the SAMPLING AND CONVERSION START section and the CONVERSION ABORT section.

READING DATA

The ADS7882 outputs full parallel data in straight binary format as shown in [Table 1](#). The parallel output is active when \overline{CS} and \overline{RD} are both low. There is a minimal quiet sampling period requirement around the falling edge of \overline{CONVST} as stated in the timing requirements section. Data reads or bus three-state operations should not be attempted within this period. Any other combination of \overline{CS} and \overline{RD} 3-states the parallel output. Refer to [Table 1](#) for ideal output codes.

Table 1. Ideal Input Voltages and Output Codes⁽¹⁾

DESCRIPTION	ANALOG VALUE	BINARY CODE	HEX CODE
Full scale	$V_{ref} - 1 \text{ LSB}$	1111 1111 1111	FFF
Midscale	$V_{ref}/2$	1000 0000 0000	800
Midscale - 1 LSB	$V_{ref}/2 - 1 \text{ LSB}$	0111 1111 1111	7FF
Zero	0 V	0000 0000 0000	000

(1) Full-scale range = V_{ref} and least significant bit (LSB) = $V_{ref}/4096$

The output data appears as a full 12-bit word (D11–D0) on pins DB11–DB0 (MSB–LSB) if BYTE is low.

READING THE DATA IN BYTE MODE

The result can also be read on an 8-bit bus for convenience by using pins DB11–DB4. In this case two reads are necessary; the first as before, leaving BYTE low and reading the 8 most significant bits on pins DB11–DB4, and then bringing BYTE high. When BYTE is high, the lower bits (D3–D0) followed by all zeros are on pins DB11–DB4 (refer to [Table 2](#)).

These multi-word read operations can be performed with multiple active \overline{RD} signals (toggling) or with \overline{RD} tied low for simplicity.

Table 2. Conversion Data Read Out

BYTE	DATA READ OUT	
	DB11–DB4	DB3–DB0
High	D3–D0, 0000	All zeroes
Low	D11–D4	D3–D0

Also refer to the DATA READ and DEVICE OPERATION AND DATA READ IN BACK-TO-BACK CONVERSION sections for more details.

Reset

Refer to the POWERDOWN/RESET section for the device reset sequence.

It is recommended to reset the device after power on. A reset can be issued once the power has reached 95% of its final value.

$\overline{\text{PWD}}/\overline{\text{RST}}$ is an asynchronous active low input signal. A current conversion is aborted no later than 45 ns after the converter is in the reset mode. In addition, the device outputs a FE0 code to indicate a reset condition. The converter returns back to normal operation mode immediately after the $\overline{\text{PWD}}/\overline{\text{RST}}$ input is brought high.

Data is not valid for the first four conversions after a device reset.

Powerdown

Refer to the POWERDOWN/RESET section for the device powerdown sequence.

The device enters powerdown mode if a $\overline{\text{PWD}}/\overline{\text{RST}}$ low duration is extended for more than a period of t_{w7} .

The converter goes back to normal operation mode no later than a period of t_{d13} after the $\overline{\text{PWD}}/\overline{\text{RST}}$ input is brought high.

After this period, normal conversion and sampling operation can be started as discussed in previous sections. Data is not valid for the first four conversions after a device reset.

Nap Mode

Refer to the NAP MODE section in the DESCRIPTION AND TIMING DIAGRAMS section for information.

APPLICATION INFORMATION

LAYOUT

For optimum performance, care should be taken with the physical layout of the ADS7882 circuitry.

As the ADS7882 offers single-supply operation, it is often used in close proximity with digital logic, micro-controllers, microprocessors, and digital signal processors. The more digital logic present in the design and the higher the switching speed, the more difficult it is to achieve acceptable performance from the converter.

The basic SAR architecture is sensitive to glitches or sudden changes on the power supply, reference, ground connections, and digital inputs that occur just prior to the end of sampling (within quiet sampling time) and just prior to latching the output of the analog comparator during the conversion phase. Thus, driving any single conversion for an n-bit SAR converter, there are n+1 windows in which large external transient voltages can affect the conversion result. Such glitches might originate from switching power supplies, nearby digital logic, or high power devices.

The degree of error in the digital output depends on the reference voltage, layout, and the exact timing of the external event.

On average, the ADS7882 draws very little current from an external reference as the reference voltage is internally buffered. If the reference voltage is external and originates from an op amp, make sure that it can drive the bypass capacitor or capacitors without oscillation. A 0.1- μ F bypass capacitor and 1- μ F storage capacitor are recommended from REFIN (pin 1) directly to REFM (pin 48).

The AGND and BDGND pins should be connected to a clean ground point. In all cases, this should be the analog ground. Avoid connections which are too close to the grounding point of a micro-controller or digital signal processor. If required, run a ground trace directly from the converter to the power supply entry point. The ideal layout consists of an analog ground plane dedicated to the converter and associated analog circuitry.

As with the AGND connections, +VA should be connected to a 5-V power supply plane that is separate from the connection for +VBD and digital logic until they are connected at the power entry point onto the PCB. Power to the ADS7882 should be clean and well bypassed. A 0.1- μ F ceramic bypass capacitor should be placed as close to the device as possible. In addition to a 0.1- μ F capacitor, a 1- μ F capacitor is recommended. In some situations, additional bypassing may be required, such as a 100- μ F electrolytic capacitor or even a Pi filter made up of inductors and capacitors, all designed to essentially low-pass filter the 5-V supply, removing the high frequency noise.

Table 3. Power Supply Decoupling Capacitor Placement

POWER SUPPLY PLANE	CONVERTER ANALOG SIDE	CONVERTER DIGITAL SIDE
SUPPLY PINS		
Pairs of pins that require a shortest path to decoupling capacitors	(4,5), (9,8), (10,11), (13, 15), (43, 44) (46, 45)	(24, 25), (34, 35)
Pins that require no decoupling	14, 12	

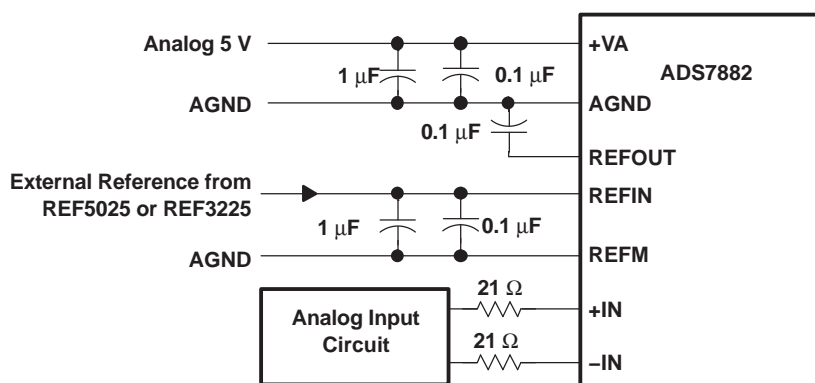

Figure 33. Using External Reference

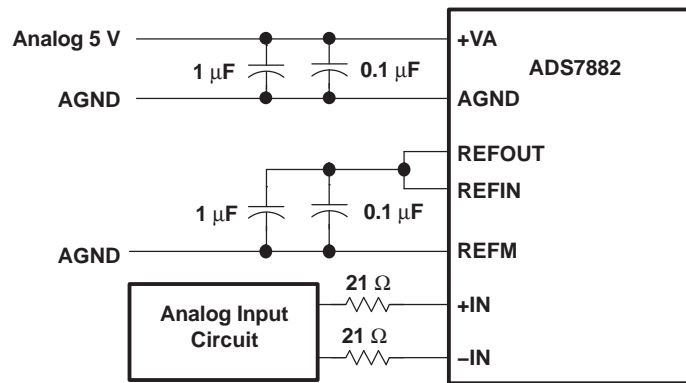

Figure 34. Using Internal Reference

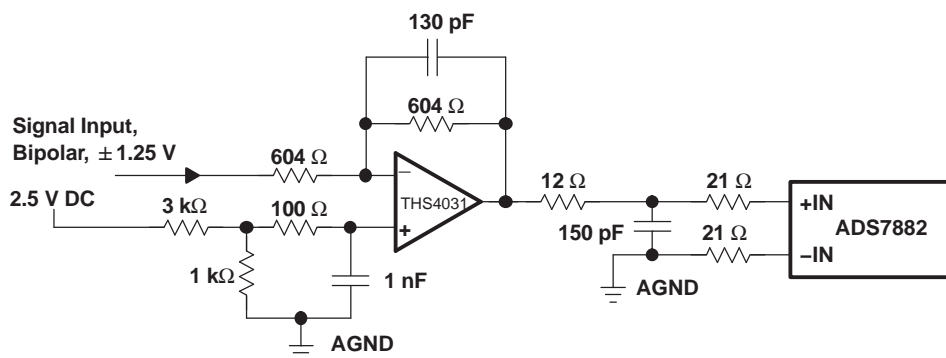

Figure 35. Typical Analog Input Circuit for Bipolar Signal

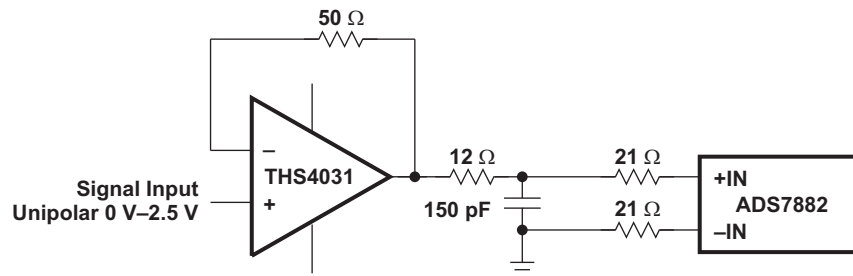

Figure 36. Typical Application Input Circuit for Unipolar Signal

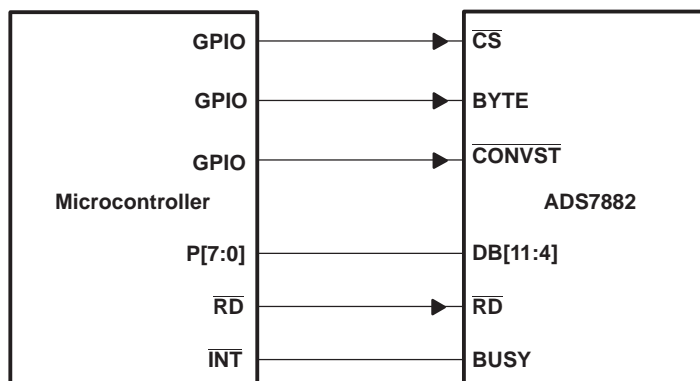

Figure 37. Interfacing With Microcontroller

PACKAGING INFORMATION

Orderable Device	Status (1)	Package Type	Package Drawing	Pins	Package Qty	Eco Plan (2)	Lead/Ball Finish	MSL Peak Temp (3)	Op Temp (°C)	Top-Side Markings (4)	Samples
ADS7882IPFBR	ACTIVE	TQFP	PFB	48	1000	Green (RoHS & no Sb/Br)	CU NIPDAU	Level-2-260C-1 YEAR	-40 to 85	ADS7882	Samples
ADS7882IPFBT	ACTIVE	TQFP	PFB	48	250	Green (RoHS & no Sb/Br)	CU NIPDAU	Level-2-260C-1 YEAR	-40 to 85	ADS7882	Samples

(1) The marketing status values are defined as follows:

ACTIVE: Product device recommended for new designs.

LIFEBUY: TI has announced that the device will be discontinued, and a lifetime-buy period is in effect.

NRND: Not recommended for new designs. Device is in production to support existing customers, but TI does not recommend using this part in a new design.

PREVIEW: Device has been announced but is not in production. Samples may or may not be available.

OBSOLETE: TI has discontinued the production of the device.

(2) Eco Plan - The planned eco-friendly classification: Pb-Free (RoHS), Pb-Free (RoHS Exempt), or Green (RoHS & no Sb/Br) - please check <http://www.ti.com/productcontent> for the latest availability information and additional product content details.

TBD: The Pb-Free/Green conversion plan has not been defined.

Pb-Free (RoHS): TI's terms "Lead-Free" or "Pb-Free" mean semiconductor products that are compatible with the current RoHS requirements for all 6 substances, including the requirement that lead not exceed 0.1% by weight in homogeneous materials. Where designed to be soldered at high temperatures, TI Pb-Free products are suitable for use in specified lead-free processes.

Pb-Free (RoHS Exempt): This component has a RoHS exemption for either 1) lead-based flip-chip solder bumps used between the die and package, or 2) lead-based die adhesive used between the die and leadframe. The component is otherwise considered Pb-Free (RoHS compatible) as defined above.

Green (RoHS & no Sb/Br): TI defines "Green" to mean Pb-Free (RoHS compatible), and free of Bromine (Br) and Antimony (Sb) based flame retardants (Br or Sb do not exceed 0.1% by weight in homogeneous material)

(3) MSL, Peak Temp. -- The Moisture Sensitivity Level rating according to the JEDEC industry standard classifications, and peak solder temperature.

(4) Multiple Top-Side Markings will be inside parentheses. Only one Top-Side Marking contained in parentheses and separated by a "~" will appear on a device. If a line is indented then it is a continuation of the previous line and the two combined represent the entire Top-Side Marking for that device.

Important Information and Disclaimer: The information provided on this page represents TI's knowledge and belief as of the date that it is provided. TI bases its knowledge and belief on information provided by third parties, and makes no representation or warranty as to the accuracy of such information. Efforts are underway to better integrate information from third parties. TI has taken and continues to take reasonable steps to provide representative and accurate information but may not have conducted destructive testing or chemical analysis on incoming materials and chemicals. TI and TI suppliers consider certain information to be proprietary, and thus CAS numbers and other limited information may not be available for release.

In no event shall TI's liability arising out of such information exceed the total purchase price of the TI part(s) at issue in this document sold by TI to Customer on an annual basis.

TAPE AND REEL INFORMATION



QUADRANT ASSIGNMENTS FOR PIN 1 ORIENTATION IN TAPE



*All dimensions are nominal

Device	Package Type	Package Drawing	Pins	SPQ	Reel Diameter (mm)	Reel Width W1 (mm)	A0 (mm)	B0 (mm)	K0 (mm)	P1 (mm)	W (mm)	Pin1 Quadrant
ADS7882IPFBR	TQFP	PFB	48	1000	330.0	16.4	9.6	9.6	1.5	12.0	16.0	Q2
ADS7882IPFBT	TQFP	PFB	48	250	180.0	16.4	9.6	9.6	1.5	12.0	16.0	Q2

TAPE AND REEL BOX DIMENSIONS

*All dimensions are nominal

Device	Package Type	Package Drawing	Pins	SPQ	Length (mm)	Width (mm)	Height (mm)
ADS7882IPFBR	TQFP	PFB	48	1000	350.0	350.0	43.0
ADS7882IPFBT	TQFP	PFB	48	250	213.0	191.0	55.0

PFB (S-PQFP-G48)

PLASTIC QUAD FLATPACK

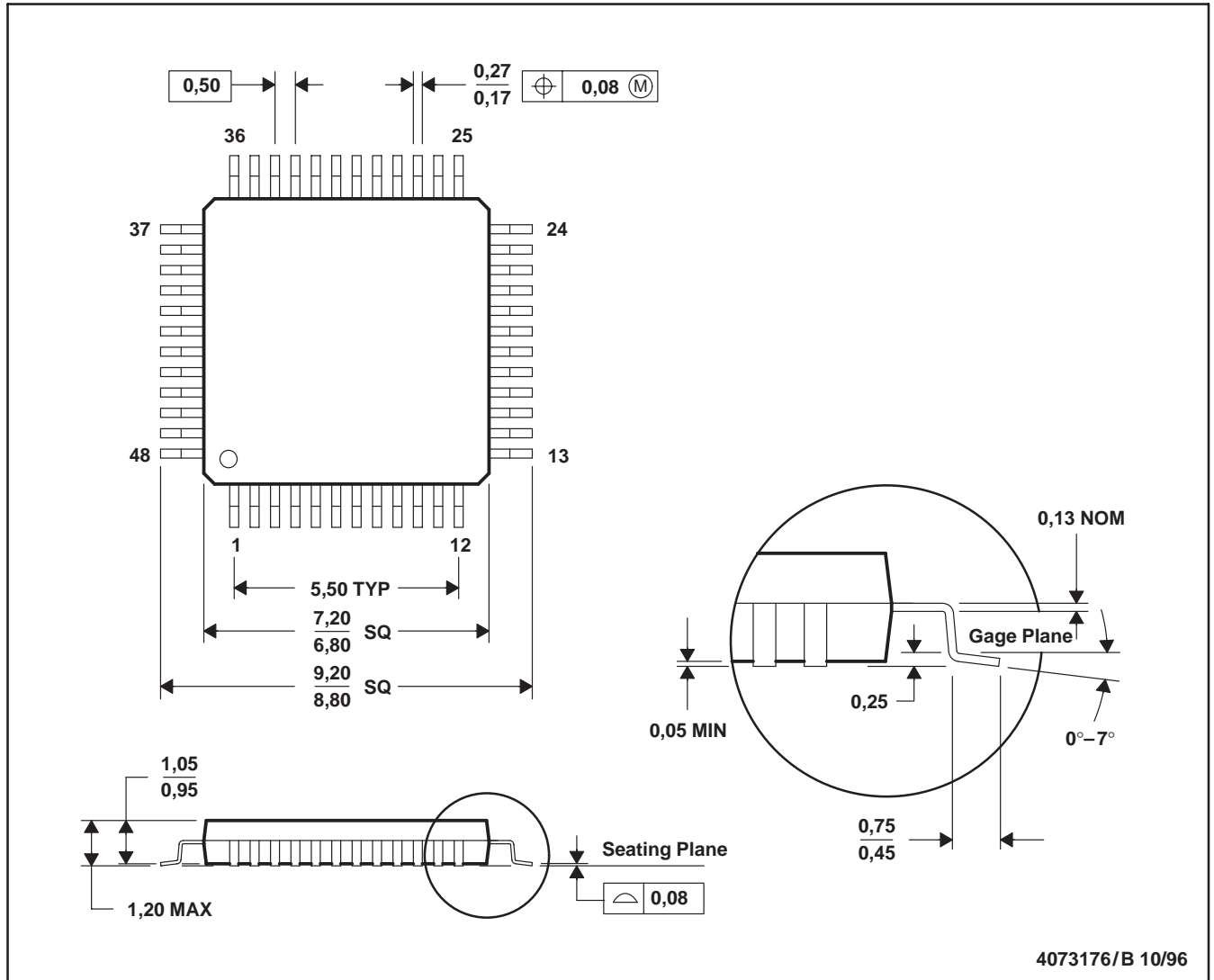

- NOTES: A. All linear dimensions are in millimeters.
 B. This drawing is subject to change without notice.
 C. Falls within JEDEC MS-026

PFB (S-PQFP-G48)



4209366/A 03/08

- NOTES:
- A. All linear dimensions are in millimeters.
 - B. This drawing is subject to change without notice.
 - C. Publication IPC-7351 is recommended for alternate designs.
 - D. Laser cutting apertures with trapezoidal walls and also rounding corners will offer better paste release. Customers should contact their board assembly site for stencil design recommendations. Refer to IPC-7525.
 - E. Customers should contact their board fabrication site for solder mask tolerances between and around signal pads.

IMPORTANT NOTICE AND DISCLAIMER

TI PROVIDES TECHNICAL AND RELIABILITY DATA (INCLUDING DATASHEETS), DESIGN RESOURCES (INCLUDING REFERENCE DESIGNS), APPLICATION OR OTHER DESIGN ADVICE, WEB TOOLS, SAFETY INFORMATION, AND OTHER RESOURCES "AS IS" AND WITH ALL FAULTS, AND DISCLAIMS ALL WARRANTIES, EXPRESS AND IMPLIED, INCLUDING WITHOUT LIMITATION ANY IMPLIED WARRANTIES OF MERCHANTABILITY, FITNESS FOR A PARTICULAR PURPOSE OR NON-INFRINGEMENT OF THIRD PARTY INTELLECTUAL PROPERTY RIGHTS.

These resources are intended for skilled developers designing with TI products. You are solely responsible for (1) selecting the appropriate TI products for your application, (2) designing, validating and testing your application, and (3) ensuring your application meets applicable standards, and any other safety, security, or other requirements. These resources are subject to change without notice. TI grants you permission to use these resources only for development of an application that uses the TI products described in the resource. Other reproduction and display of these resources is prohibited. No license is granted to any other TI intellectual property right or to any third party intellectual property right. TI disclaims responsibility for, and you will fully indemnify TI and its representatives against, any claims, damages, costs, losses, and liabilities arising out of your use of these resources.

TI's products are provided subject to TI's Terms of Sale (www.ti.com/legal/termsofsale.html) or other applicable terms available either on ti.com or provided in conjunction with such TI products. TI's provision of these resources does not expand or otherwise alter TI's applicable warranties or warranty disclaimers for TI products.

Mailing Address: Texas Instruments, Post Office Box 655303, Dallas, Texas 75265
Copyright © 2019, Texas Instruments Incorporated

Looking for pricing, stock, or lifecycle information?

Click below to explore more details on WIN SOURCE:

 [View ADS7882IPFBT on WIN SOURCE](#)

 [Texas Instruments](#) Information

Optimize Your Supply Chain with WIN SOURCE Solutions

-  Global Sourcing Solution
-  Obsolete Management
-  Cost Control Management
-  Shortage Management
-  Alternative Solution
-  Excess Inventory Management