



**THE DATASHEET OF
TPS54540QDDARQ1**



TPS54540-Q1 4.5-V to 42-V Input, 5-A, Step-Down DC-DC Converter With Eco-mode™

1 Features

- Qualified for Automotive Applications
- AEC-Q100 Qualified With the Following Results:
 - Device Temperature Grade 1: –40°C to 125°C Ambient Operating Temperature Range
 - Device HBM ESD Classification Level H1C
 - Device CDM ESD Classification Level C3B
- High-Efficiency at Light Loads With Pulse-Skipping Eco-mode™
- 92-mΩ High-Side MOSFET
- 146-μA Operating Quiescent Current and 2-μA Shutdown Current
- 100-kHz to 2.5-MHz Adjustable Switching Frequency
- Synchronizes to External Clock
- Low Dropout at Light Loads With Integrated BOOT Recharge FET
- Adjustable UVLO Voltage and Hysteresis
- 0.8-V 1% Internal Voltage Reference
- 8-Pin HSOP PowerPAD™ Package
- –40°C to 150°C T_J Operating Range
- Supported by WEBENCH® Software Tool

2 Applications

- Vehicle Accessories: GPS (See [SLVA412](#)), Entertainment, ADAS, eCall
- USB-Dedicated Charging Ports and Battery Chargers (See [SLVA464](#))
- Industrial Automation and Motor Control
- 12-V, 24-V, and 48-V Industrial, Automotive, and Communications Power Systems

3 Description

The TPS54540-Q1 device is a 42-V, 5-A, step-down regulator with an integrated high-side MOSFET. The device survives load-dump pulses up to 65 V per ISO 7637. Current mode control provides simple external compensation and flexible component selection. A low-ripple pulse-skip mode reduces the no load supply current to 146 μA. Shutdown supply current is reduced to 2 μA when the enable pin is pulled low.

Undervoltage lockout is internally set at 4.3 V but can be increased using an external resistor divider at the enable pin. The output voltage start-up ramp is internally controlled to provide a controlled start-up and eliminate overshoot.

A wide adjustable frequency range allows either efficiency or external component size to be optimized. Output current is limited cycle-by-cycle. Frequency foldback and thermal shutdown protect internal and external components during an overload condition.

The TPS54540-Q1 is available in an 8-pin thermally-enhanced HSOP PowerPAD package.

Device Information⁽¹⁾

PART NUMBER	PACKAGE	BODY SIZE (NOM)
TPS54540-Q1	HSOP (8)	4.89 mm x 3.90 mm

(1) For all available packages, see the orderable addendum at the end of the data sheet.

Simplified Schematic

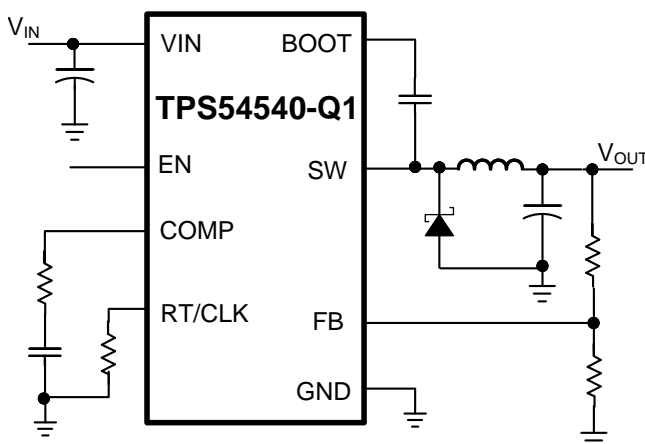

Efficiency vs Load Current

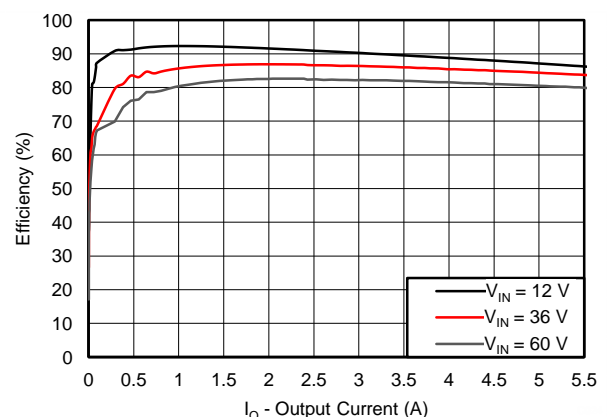

Table of Contents

1 Features 1 2 Applications 1 3 Description 1 4 Revision History 2 5 Pin Configuration and Functions 3 6 Specifications 4 6.1 Absolute Maximum Ratings 4 6.2 ESD Ratings..... 4 6.3 Recommended Operating Conditions..... 4 6.4 Thermal Information 4 6.5 Electrical Characteristics..... 5 6.6 Timing Requirements 5 6.7 Switching Characteristics 6 6.8 Typical Characteristics 7 7 Detailed Description 11 7.1 Overview 11 7.2 Functional Block Diagram 12 7.3 Feature Description..... 12	7.4 Device Functional Modes..... 22 8 Application and Implementation 23 8.1 Application Information..... 23 8.2 Typical Applications 23 9 Power Supply Recommendations 36 10 Layout 37 10.1 Layout Guidelines 37 10.2 Layout Example 37 10.3 Estimated Circuit Area 37 11 Device and Documentation Support 38 11.1 Device Support..... 38 11.2 Documentation Support 38 11.3 Community Resources..... 38 11.4 Trademarks 38 11.5 Electrostatic Discharge Caution..... 38 11.6 Glossary 38 12 Mechanical, Packaging, and Orderable Information 39
---	---

4 Revision History

NOTE: Page numbers for previous revisions may differ from page numbers in the current version.

Changes from Revision A (October 2013) to Revision B

Page

<ul style="list-style-type: none"> • ESD Ratings table, Feature Description section, Device Functional Modes, Application and Implementation section, Power Supply Recommendations section, Layout section, Device and Documentation Support section, and Mechanical, Packaging, and Orderable Information section 1 • Changed Thermal Information table values..... 4 	<p>1 4</p>
--	----------------

Changes from Original (September 2013) to Revision A

Page

<ul style="list-style-type: none"> • Changed the Electrostatic Discharge (CDM) Max value From: 500 V To: 750 V 4 • Changed the ELECTRICAL CHARACTERISTICS condition statement From: $T_j = -40^{\circ}\text{C}$ to 150°C, $V_{IN} = 4.5$ to 60 V To: $T_j = -40^{\circ}\text{C}$ to 150°C, $V_{IN} = 4.5$ to 42 V..... 5 • Changed Figure 4 X-axis From: max = 60V To: max = 45V 7 • Changed Figure 16 X-axis From: max = 60V To: max = 45V 8 • Changed Figure 18 X-axis From: max = 60V To: max = 45V 8 • Changed the FBD, removed the Logic block and Shutdown signal from the OV comparator 12 • Changed the APPLICATION INFORMATION section..... 23 	<p>4 5 7 8 8 12 23</p>
--	--

5 Pin Configuration and Functions

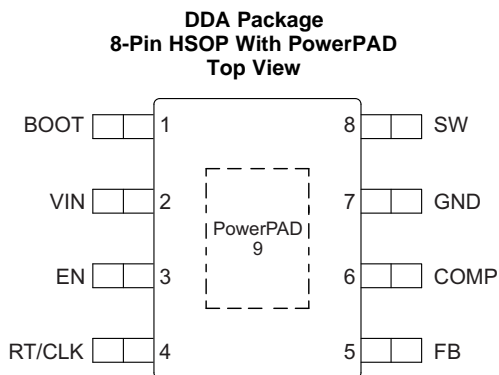

Pin Functions

PIN		I/O	DESCRIPTION
NAME	NO.		
BOOT	1	I	A bootstrap capacitor is required between BOOT and SW. If the voltage on this capacitor is below the minimum required to operate the high side MOSFET, the MOSFET stops switching until the capacitor is refreshed.
COMP	6	I	Error amplifier output and input to the output switch current (PWM) comparator. Connect frequency compensation components to this pin.
EN	3	I	Enable pin, with internal pullup current source. Pull below 1.2 V to disable. Float to enable. Adjust the input undervoltage lockout with two resistors. See the Enable and Adjusting Undervoltage Lockout section.
FB	5	I	Inverting input of the transconductance (gm) error amplifier.
GND	7	—	Ground
RT/CLK	4	I	Resistor Timing and External Clock. An internal amplifier holds this pin at a fixed voltage when using an external resistor to ground to set the switching frequency. If the pin is pulled above the PLL upper threshold, a mode change occurs and the pin becomes a synchronization input. The internal amplifier is disabled and the pin is a high impedance clock input to the internal PLL. If clocking edges stop, the internal amplifier is reenabled and the operating mode returns to resistor frequency programming.
SW	8	O	The source of the internal high-side power MOSFET and switching node of the converter.
VIN	2	I	Input supply voltage is connected to this pin with a 4.5-V to 42-V operating range.
PowerPAD	9	—	GND pin must be electrically connected to the exposed pad on the printed-circuit-board for proper operation.

6 Specifications

6.1 Absolute Maximum Ratings

over operating free-air temperature range (unless otherwise noted)⁽¹⁾

		MIN	MAX	UNIT
Voltage	V _{IN}	−0.3	65	V
	EN	−0.3	8.4	
	FB	−0.3	3	
	COMP	−0.3	3	
	RT/CLK	−0.3	3.6	
	BOOT-SW	−0.3	8	
	SW	−0.6	65	
	SW, 10-ns Transient	−2	65	
Operating junction temperature		−40	150	°C
Storage temperature, T _{stg}		−65	150	°C

(1) Stresses beyond those listed under *Absolute Maximum Ratings* may cause permanent damage to the device. These are stress ratings only, which do not imply functional operation of the device at these or any other conditions beyond those indicated under *Recommended Operating Conditions*. Exposure to absolute-maximum-rated conditions for extended periods may affect device reliability.

6.2 ESD Ratings

		VALUE	UNIT
V _(ESD)	Electrostatic discharge	Human body model (HBM), per ANSI/ESDA/JEDEC JS-001 ⁽¹⁾	±2000
		Charged-device model (CDM), per JEDEC specification JESD22-C101 ⁽²⁾	±750

(1) JEDEC document JEP155 states that 500-V HBM allows safe manufacturing with a standard ESD control process.

(2) JEDEC document JEP157 states that 250-V CDM allows safe manufacturing with a standard ESD control process.

6.3 Recommended Operating Conditions

over operating free-air temperature range (unless otherwise noted)

		MIN	NOM	MAX	UNIT
V _{IN}	Input supply voltage	4.5		60	V
V _O	Output voltage	0.8		58.8	V
I _O	Output current	0		5	A
T _J	Junction Temperature	−40		150	°C

6.4 Thermal Information

THERMAL METRIC ⁽¹⁾		TPS54540-Q1	UNIT
		DDA (HSOP)	
		8 PINS	
R _{θJA}	Junction-to-ambient thermal resistance	41.7	°C/W
R _{θJC(top)}	Junction-to-case (top) thermal resistance	52.7	°C/W
R _{θJB}	Junction-to-board thermal resistance	22.6	°C/W
Ψ _{JT}	Junction-to-top characterization parameter	7.9	°C/W
Ψ _{JB}	Junction-to-board characterization parameter	22.5	°C/W
R _{θJC(bot)}	Junction-to-case (bottom) thermal resistance	2.6	°C/W

(1) For more information about traditional and new thermal metrics, see the *Semiconductor and IC Package Thermal Metrics* application report, [SPRA953](#).

6.5 Electrical Characteristics

$T_J = -40^{\circ}\text{C}$ to 150°C , $V_{IN} = 4.5\text{ V}$ to 42 V (unless otherwise noted)

PARAMETER	TEST CONDITIONS	MIN	TYP	MAX	UNIT
SUPPLY VOLTAGE (VIN PIN)					
Operating input voltage		4.5		42	V
Internal undervoltage lockout threshold	Rising	4.1	4.3	4.48	V
Internal undervoltage lockout threshold hysteresis			325		mV
Shutdown supply current	$EN = 0\text{ V}$, 25°C , $4.5\text{ V} \leq V_{IN} \leq 42\text{ V}$		2.25	4.5	μA
Operating: nonswitching supply current	$FB = 0.9\text{ V}$, $T_A = 25^{\circ}\text{C}$		146	175	μA
ENABLE AND UVLO (EN PIN)					
Enable threshold voltage	No voltage hysteresis, rising and falling	1.1	1.2	1.3	V
Input current	Enable threshold 50 mV		-4.6		μA
	Enable threshold -50 mV	-0.58	-1.2	-1.8	μA
Hysteresis current		-2.2	-3.4	-4.5	μA
INTERNAL SOFT-START TIME					
Soft-start time	$f_{\text{SW}} = 500\text{ kHz}$, 10% to 90%		2.1		ms
Soft-start time	$f_{\text{SW}} = 2.5\text{ MHz}$, 10% to 90%		0.42		ms
VOLTAGE REFERENCE					
Voltage reference		0.792	0.8	0.808	V
HIGH-SIDE MOSFET					
On-resistance	$V_{IN} = 12\text{ V}$, $\text{BOOT-SW} = 6\text{ V}$		92	190	m Ω
ERROR AMPLIFIER					
Input current			50		nA
Error amplifier transconductance (g_m)	$-2\text{ }\mu\text{A} < I_{\text{COMP}} < 2\text{ }\mu\text{A}$, $V_{\text{COMP}} = 1\text{ V}$		350		μS
Error amplifier transconductance (g_m) during soft-start	$-2\text{ }\mu\text{A} < I_{\text{COMP}} < 2\text{ }\mu\text{A}$, $V_{\text{COMP}} = 1\text{ V}$, $V_{\text{FB}} = 0.4\text{ V}$		77		μS
Error amplifier DC gain	$V_{\text{FB}} = 0.8\text{ V}$		10000		V/V
Minimum unity gain bandwidth			2500		kHz
Error amplifier source and sink	$V_{(\text{COMP})} = 1\text{ V}$, 100-mV overdrive		± 30		μA
COMP to SW current transconductance			17		A/V
CURRENT LIMIT					
Current limit threshold	All V_{IN} and temperatures, Open Loop ⁽¹⁾	6.3	7.5	8.8	A
	All temperatures, $V_{IN} = 12\text{ V}$, Open Loop ⁽¹⁾	6.3	7.5	8.3	
	$V_{IN} = 12\text{ V}$, $T_A = 25^{\circ}\text{C}$, Open Loop ⁽¹⁾	7.1	7.5	7.9	
THERMAL SHUTDOWN					
Thermal shutdown			176		$^{\circ}\text{C}$
Thermal shutdown hysteresis			12		$^{\circ}\text{C}$
ERROR AMPLIFIER					
Enable to COMP active	$V_{IN} = 12\text{ V}$, $T_A = 25^{\circ}\text{C}$		540		μs

(1) Open-loop current limit measured directly at the SW pin and is independent of the inductor value and slope compensation.

6.6 Timing Requirements

$T_J = -40^{\circ}\text{C}$ to 150°C , $V_{IN} = 4.5\text{ V}$ to 42 V (unless otherwise noted)

	MIN	NOM	MAX	UNIT
RT/CLK				
Minimum CLK input pulse width		15		ns

6.7 Switching Characteristics

 $T_J = -40^{\circ}\text{C}$ to 150°C , $V_{IN} = 4.5\text{ V}$ to 42 V (unless otherwise noted)

	PARAMETER	TEST CONDITIONS	MIN	TYP	MAX	UNIT
CURRENT LIMIT						
	Current limit threshold delay			60		ns
RT/CLK						
	Switching frequency range using RT mode		100		2500	kHz
f_{SW}	Switching frequency	$R_T = 200\text{ k}\Omega$	450	500	550	kHz
	Switching frequency range using CLK mode		160		2300	kHz
	RT/CLK high threshold			1.55	2	V
	RT/CLK low threshold		0.5	1.2		V
	RT/CLK falling edge to SW rising edge delay	Measured at 500 kHz with RT resistor in series		55		ns
	PLL lock in time	Measured at 500 kHz		78		μs

6.8 Typical Characteristics

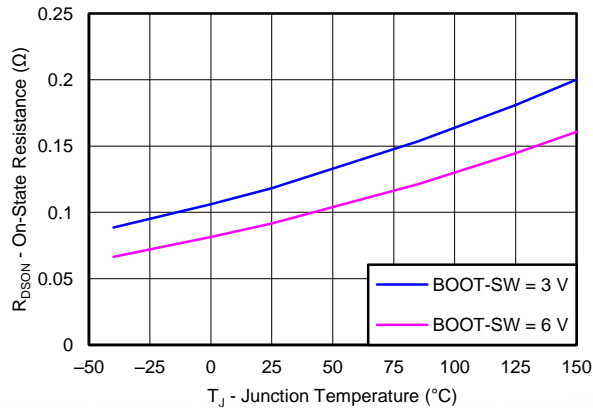

Figure 1. ON-Resistance vs Junction Temperature

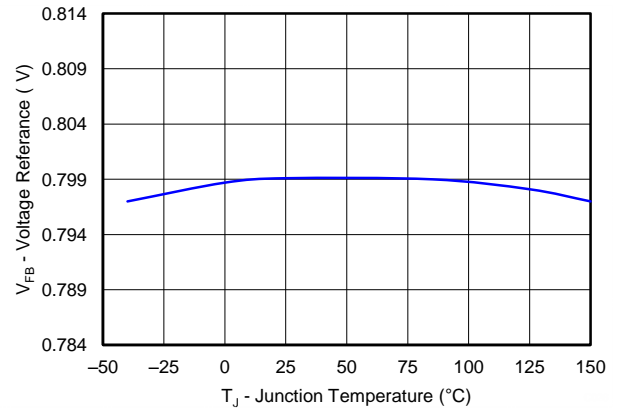

Figure 2. Voltage Reference vs Junction Temperature

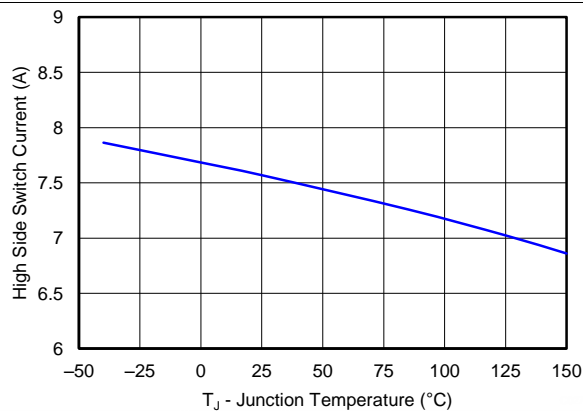

Figure 3. Switch Current Limit vs Junction Temperature

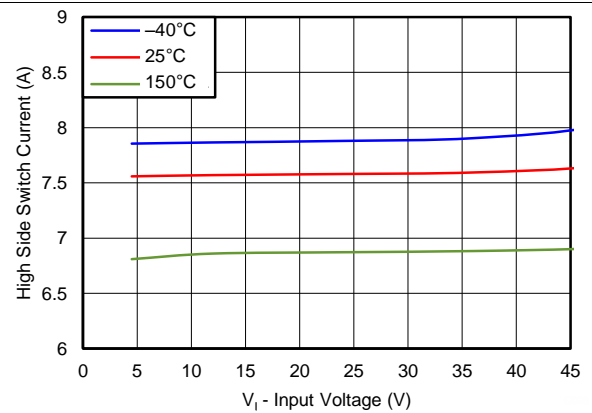

Figure 4. Switch Current Limit vs Input Voltage

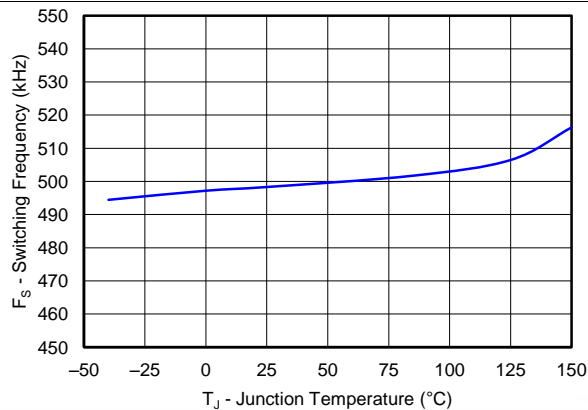

Figure 5. Switching Frequency vs Junction Temperature

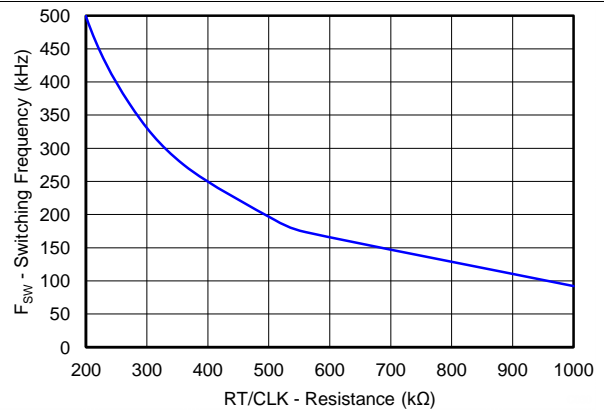

Figure 6. Switching Frequency vs RT/CLK Resistance Low-Frequency Range

Typical Characteristics (continued)

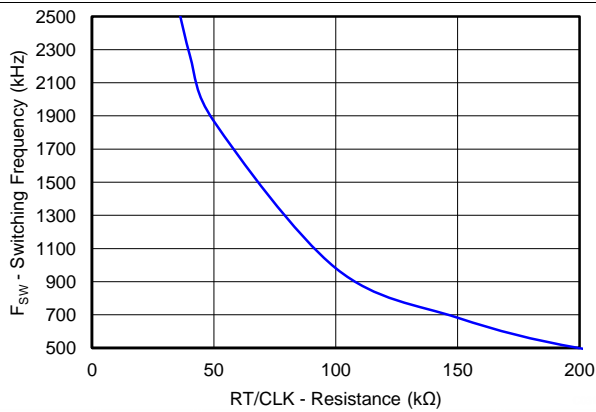

Figure 7. Switching Frequency vs RT/CLK Resistance High-Frequency Range

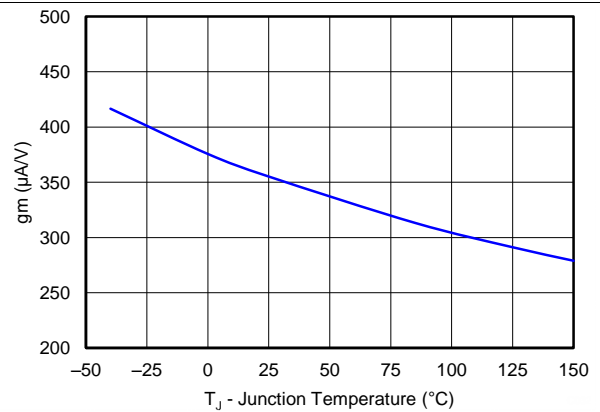

Figure 8. EA Transconductance vs Junction Temperature

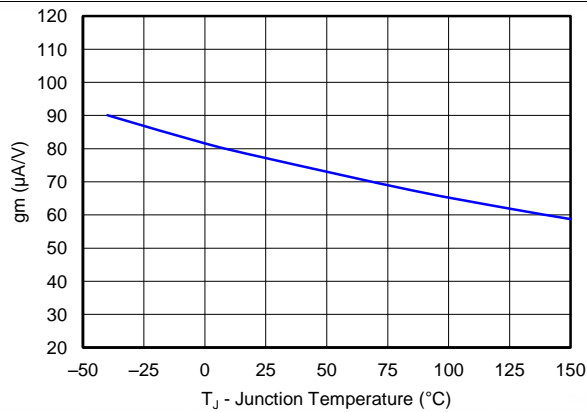

Figure 9. EA Transconductance During Soft-Start vs Junction Temperature

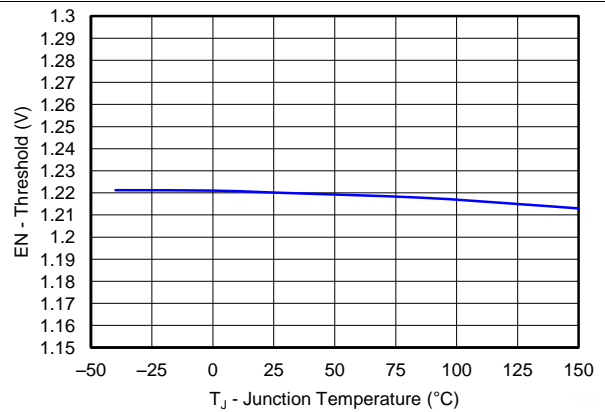

Figure 10. EN Pin Voltage vs Junction Temperature

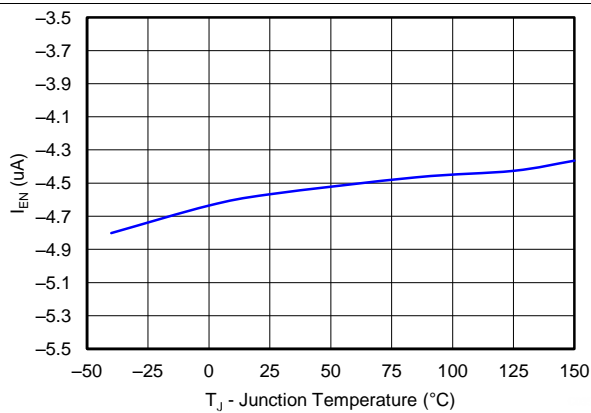

Figure 11. EN Pin Current vs Junction Temperature

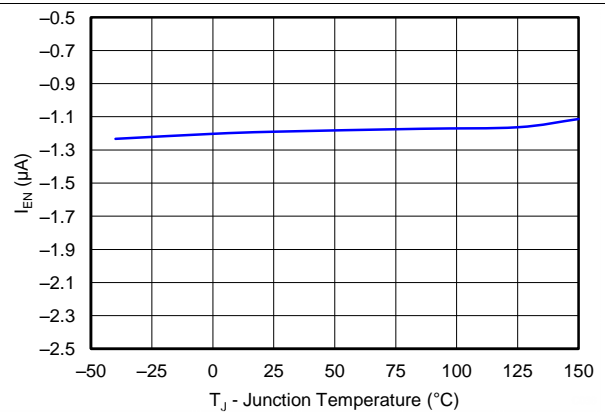

Figure 12. EN Pin Current vs Junction Temperature

Typical Characteristics (continued)

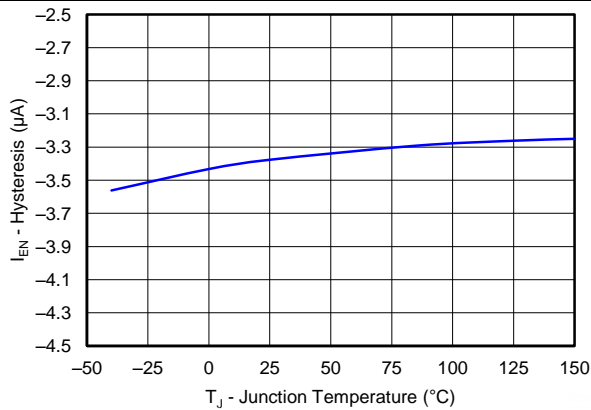

Figure 13. EN Pin Current Hysteresis vs Junction Temperature

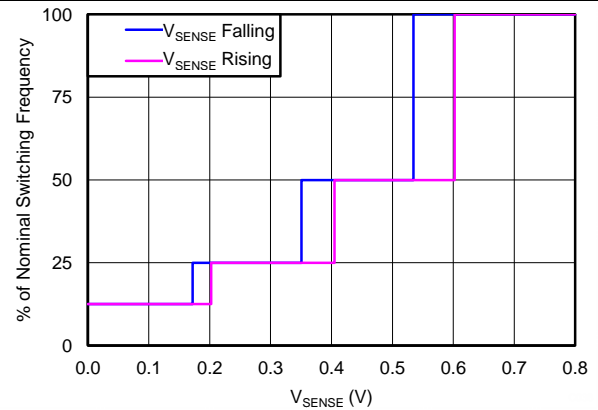

Figure 14. Switching Frequency vs V_{SENSE}

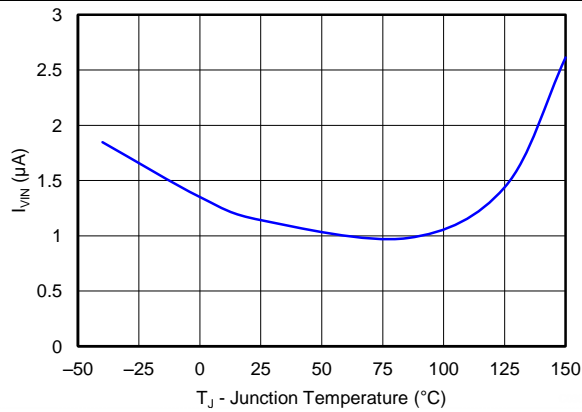

Figure 15. Shutdown Supply Current vs Junction Temperature

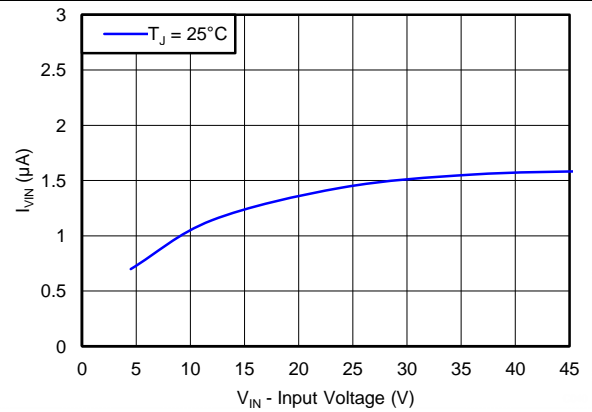

Figure 16. Shutdown Supply Current vs Input Voltage (V_{IN})

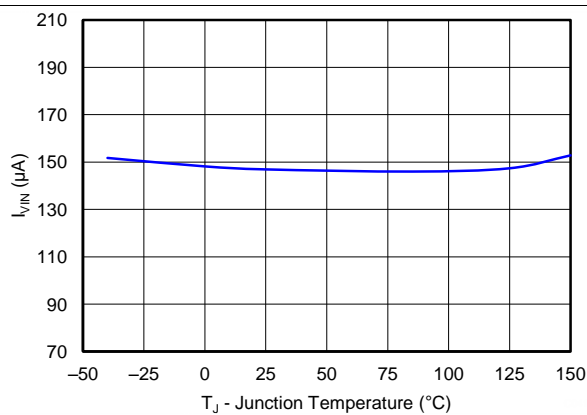

Figure 17. V_{IN} Supply Current vs Junction Temperature

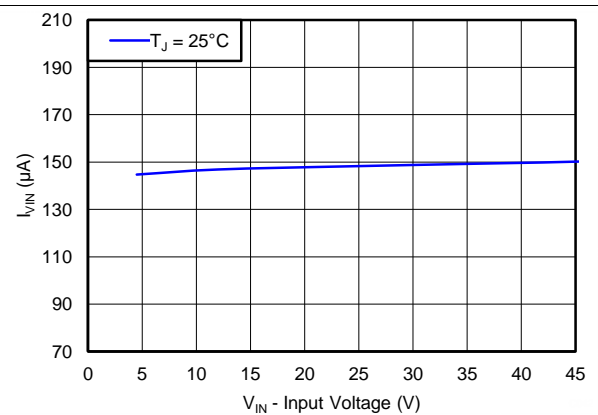

Figure 18. V_{IN} Supply Current vs Input Voltage

Typical Characteristics (continued)

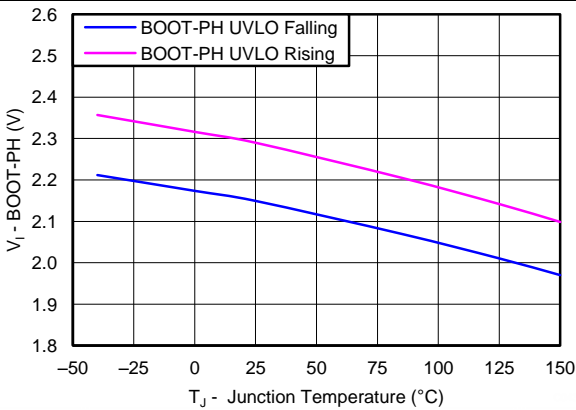

Figure 19. BOOT-SW UVLO vs Junction Temperature

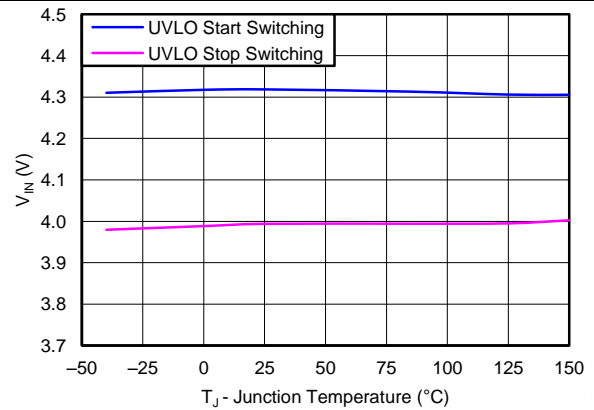

Figure 20. Input Voltage UVLO vs Junction Temperature

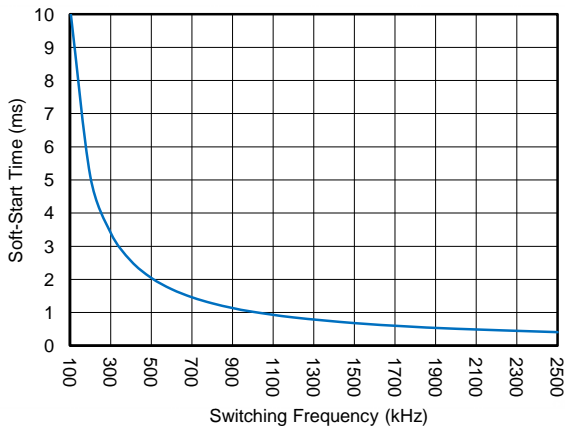

Figure 21. Soft-Start Time vs Switching Frequency

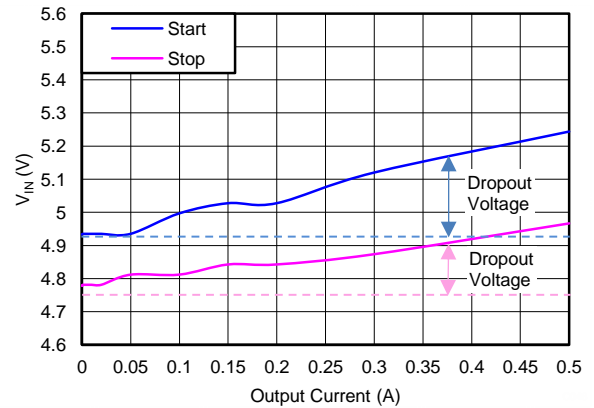

Figure 22. 5-V Start and Stop Voltage
(See [Low Dropout Operation and Bootstrap Voltage \(BOOT\)](#))

7 Detailed Description

7.1 Overview

The TPS54540-Q1 device is a 42-V, 5-A, step-down (buck) regulator with an integrated high-side N-channel MOSFET. The device implements constant frequency, current mode control that reduces output capacitance and simplifies external frequency compensation. The wide switching frequency range of 100 kHz to 2500 kHz allows either efficiency or size optimization when selecting the output filter components. The switching frequency is adjusted using a resistor to ground connected to the RT/CLK pin. The device has an internal phase-locked loop (PLL) connected to the RT/CLK pin that will synchronize the power switch turnon to a falling edge of an external clock signal.

The TPS54540-Q1 device has a default input start-up voltage of approximately 4.3 V. The EN pin can be used to adjust the input voltage undervoltage lockout (UVLO) threshold with two external resistors. An internal pullup current source enables operation when the EN pin is floating. The operating current is 146 μ A under no load condition (not switching). When the device is disabled, the supply current is 2 μ A.

The integrated 92-m Ω high-side MOSFET supports high-efficiency power supply designs capable of delivering 5 A of continuous current to a load. The gate drive bias voltage for the integrated high-side MOSFET is supplied by a bootstrap capacitor connected from the BOOT to SW pins. The TPS54540-Q1 device reduces the external component count by integrating the bootstrap recharge diode. The BOOT pin capacitor voltage is monitored by a UVLO circuit which turns off the high-side MOSFET when the BOOT to SW voltage falls below a preset threshold. An automatic BOOT capacitor recharge circuit allows the TPS54540-Q1 device to operate at high duty cycles approaching 100%. Therefore, the maximum output voltage is near the minimum input supply voltage of the application. The minimum output voltage is the internal 0.8-V feedback reference.

Output overvoltage transients are minimized by an Overvoltage Protection (OVP) comparator. When the OVP comparator is activated, the high-side MOSFET is turned off and remains off until the output voltage is less than 106% of the desired output voltage.

The TPS54540-Q1 device includes an internal soft-start circuit that slows the output rise time during start-up to reduce in-rush current and output voltage overshoot. Output overload conditions reset the soft-start timer. When the overload condition is removed, the soft-start circuit controls the recovery from the fault output level to the nominal regulation voltage. A frequency foldback circuit reduces the switching frequency during start-up and overcurrent fault conditions to help maintain control of the inductor current.

7.2 Functional Block Diagram

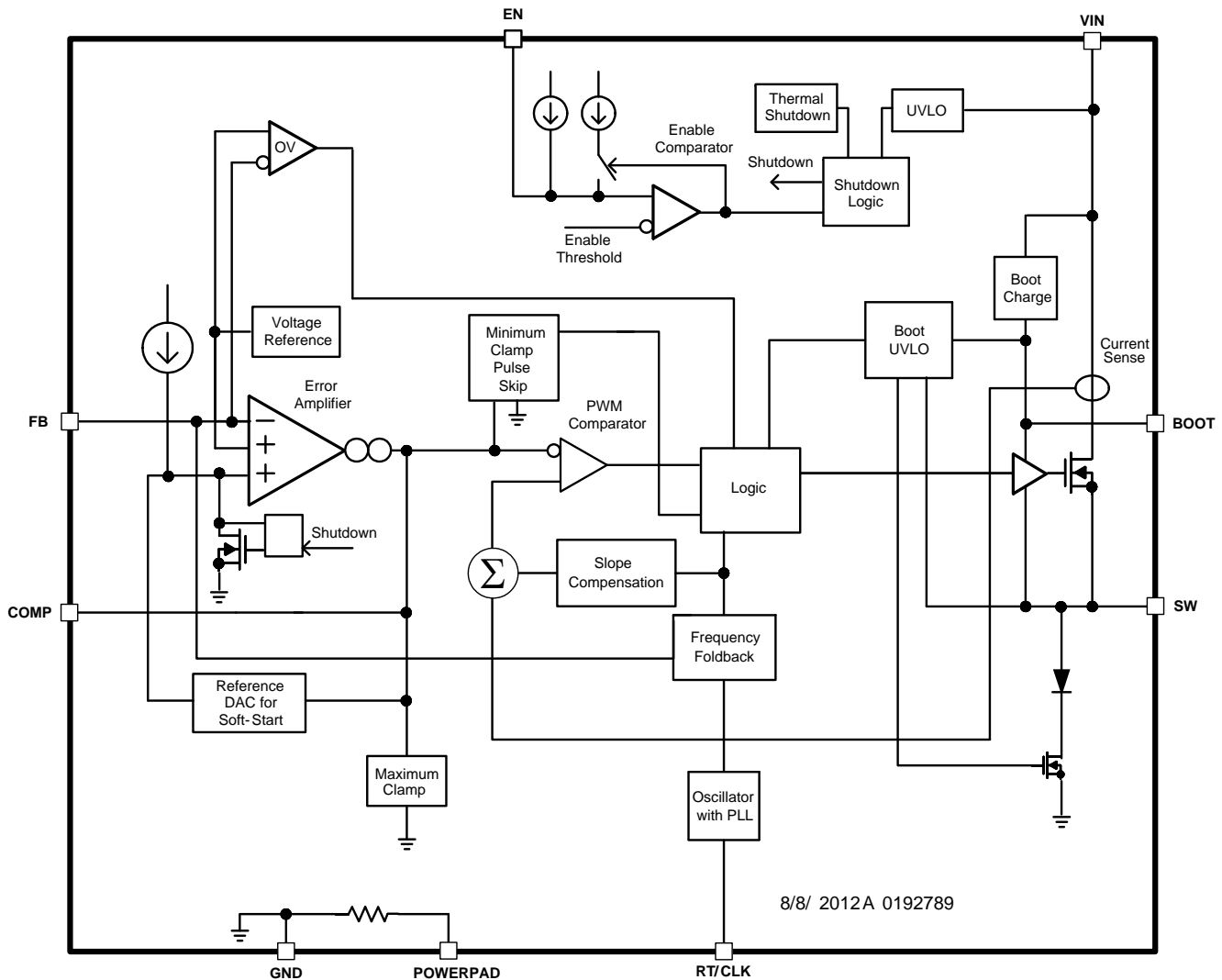

7.3 Feature Description

7.3.1 Fixed Frequency PWM Control

The TPS54540-Q1 device uses fixed frequency, peak current mode control with adjustable switching frequency. The output voltage is compared through external resistors connected to the FB pin to an internal voltage reference by an error amplifier. An internal oscillator initiates the turnon of the high-side power switch. The error amplifier output at the COMP pin controls the high-side power switch current. When the high-side MOSFET switch current reaches the threshold level set by the COMP voltage, the power switch is turned off. The COMP pin voltage will increase and decrease as the output current increases and decreases. The device implements current limiting by clamping the COMP pin voltage to a maximum level. The pulse skipping Eco-mode is implemented with a minimum voltage clamp on the COMP pin.

7.3.2 Slope Compensation Output Current

The TPS54540-Q1 device adds a compensating ramp to the MOSFET switch current sense signal. This slope compensation prevents sub-harmonic oscillations at duty cycles greater than 50%. The peak current limit of the high-side switch is not affected by the slope compensation and remains constant over the full duty cycle range.

Feature Description (continued)

7.3.3 Pulse-Skip Eco-mode

The TPS54540-Q1 device operates in a pulse-skipping Eco-mode at light load currents to improve efficiency by reducing switching and gate drive losses. If the output voltage is within regulation and the peak switch current at the end of any switching cycle is below the pulse skipping current threshold, the device enters Eco-mode. The pulse skipping current threshold is the peak switch current level corresponding to a nominal COMP voltage of 600 mV.

When in Eco-mode, the COMP pin voltage is clamped at 600 mV and the high-side MOSFET is inhibited. Because the device is not switching, the output voltage begins to decay. The voltage control loop responds to the falling output voltage by increasing the COMP pin voltage. The high-side MOSFET is enabled and switching resumes when the error amplifier lifts COMP above the pulse skipping threshold. The output voltage recovers to the regulated value, and COMP eventually falls below the Eco-mode pulse skipping threshold at which time the device again enters Eco-mode. The internal PLL remains operational when in Eco-mode. When operating at light load currents in Eco-mode, the switching transitions occur synchronously with the external clock signal.

During Eco-mode operation, the TPS54540-Q1 device senses and controls peak switch current, not the average load current. Therefore the load current at which the device enters Eco-mode is dependent on the output inductor value. As the load current approaches zero, the device enters a pulse-skip mode during which it draws only 152 μ A of input quiescent current. The circuit in [Figure 34](#) enters Eco-mode at about 18-mA output current, and with no external load has an average input current of 240 μ A.

7.3.4 Low Dropout Operation and Bootstrap Voltage (BOOT)

The TPS54540-Q1 device provides an integrated bootstrap voltage regulator. A small capacitor between the BOOT and SW pins provides the gate drive voltage for the high-side MOSFET. The BOOT capacitor is refreshed when the high-side MOSFET is off and the external low-side diode conducts. The recommended value of the BOOT capacitor is 0.1 μ F. For stable performance over temperature and voltage, TI recommends a ceramic capacitor with an X7R or X5R grade dielectric with a voltage rating of 10 V or higher.

When operating with a low voltage difference from input to output, the high-side MOSFET of the TPS54540-Q1 device will operate at 100% duty cycle as long as the BOOT to SW pin voltage is greater than 2.1 V. When the voltage from BOOT to SW drops to less than 2.1 V, the high-side MOSFET is turned off and an integrated low-side MOSFET pulls SW low to recharge the BOOT capacitor. To reduce the losses of the small low-side MOSFET at high-output voltages, it is disabled at 24-V output and reenabled when the output reaches 21.5 V.

Because the gate drive current sourced from the BOOT capacitor is small, the high-side MOSFET can remain on for many switching cycles before the MOSFET is turned off to refresh the capacitor. Thus, the effective duty cycle of the switching regulator can be high, approaching 100%. The effective duty cycle of the converter during dropout is mainly influenced by the voltage drops across the power MOSFET, the inductor resistance, the low-side diode voltage and the printed-circuit-board resistance.

The start and stop voltage for a typical 5-V output application is shown in [Figure 22](#) where the V_{IN} voltage is plotted versus load current. The start voltage is defined as the input voltage needed to regulate the output within 1% of nominal. The stop voltage is defined as the input voltage at which the output drops by 5% or where switching stops.

During high duty cycle (low dropout) conditions, inductor current ripple increases when the BOOT capacitor is being recharged resulting in an increase in output voltage ripple. Increased ripple occurs when the off time required to recharge the BOOT capacitor is longer than the high-side off time associated with cycle-by-cycle PWM control.

Feature Description (continued)

At heavy loads, the minimum input voltage must be increased to insure a monotonic start-up. Equation 1 can be used to calculate the minimum input voltage for this condition.

$$V_{Omax} = D_{max} \times (V_{VINmin} - I_{Omax} \times R_{DS(on)} + V_d) - V_d - I_{Omax} \times R_{dc}$$

where

- $D_{max} \geq 0.9$
 - V_d = Forward Drop of the Catch Diode
 - $R_{DS(on)} = 1 / (-0.3 \times VB2SW^2 + 3.577 \times VB2SW - 4.246)$
 - $VB2SW = VBOOT + V_d$
 - $VBOOT = (1.41 \times V_{VIN} - 0.554 - V_d \times f_{SW} - 1.847 \times 10^3 \times IB2SW) / (1.41 + f_{SW})$
 - $IB2SW = 100 \times 10^{-6}A$
- (1)

7.3.5 Error Amplifier

The TPS54540-Q1 voltage regulation loop is controlled by a transconductance error amplifier. The error amplifier compares the FB pin voltage to the lower of the internal soft-start voltage or the internal 0.8-V voltage reference. The transconductance (gm) of the error amplifier is 350 $\mu A/V$ during normal operation. During soft-start operation, the transconductance is reduced to 78 $\mu A/V$ and the error amplifier is referenced to the internal soft-start voltage.

The frequency compensation components (capacitor, series resistor and capacitor) are connected between the error amplifier output COMP pin and GND pin.

7.3.6 Adjusting the Output Voltage

The internal voltage reference produces a precise 0.8 V $\pm 1\%$ voltage reference over the operating temperature and voltage range by scaling the output of a bandgap reference circuit. The output voltage is set by a resistor divider from the output node to the FB pin. TI recommends using 1% tolerance or better divider resistors. Select the low-side resistor R_{LS} for the desired divider current and use Equation 2 to calculate R_{HS} . To improve efficiency at light loads consider using larger value resistors. However, if the values are too high, the regulator will be more susceptible to noise and voltage errors from the FB input current may become noticeable.

$$R_{HS} = R_{LS} \times \left(\frac{V_{out} - 0.8V}{0.8V} \right)$$
(2)

7.3.7 Enable and Adjusting Undervoltage Lockout

The TPS54540-Q1 device is enabled when the VIN pin voltage is greater than 4.3 V and the EN pin voltage exceeds the enable threshold of 1.2 V. The TPS54540-Q1 device is disabled when the VIN pin voltage falls less than 4 V or when the EN pin voltage is less than 1.2 V. The EN pin has an internal pullup current source, I1, of 1.2 μA that enables operation of the TPS54540-Q1 device when the EN pin floats.

If an application requires a higher undervoltage lockout (UVLO) threshold, use the circuit shown in Figure 23 to adjust the input voltage UVLO with two external resistors. When the EN pin voltage exceeds 1.2 V, an additional 3.4 μA of hysteresis current, I_{HYS} , is sourced out of the EN pin. When the EN pin is pulled to less than 1.2 V, the 3.4- μA I_{HYS} current is removed. This additional current facilitates adjustable input voltage UVLO hysteresis. Use Equation 3 to calculate R_{UVLO1} for the desired UVLO hysteresis voltage. Use Equation 4 to calculate R_{UVLO2} for the desired VIN start voltage.

In applications designed to start at relatively low input voltages (that is, from 4.5 V to 9 V) and withstand high input voltages (for example, 40 V), the EN pin may experience a voltage greater than the absolute maximum voltage of 8.4 V during the high input voltage condition. To avoid exceeding this voltage when using the EN resistors, the EN pin is clamped internally with a 5.8 V Zener diode that will sink up to 150 μA .

Feature Description (continued)

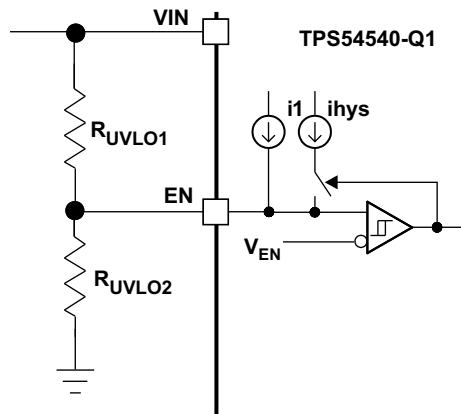

Figure 23. Adjustable Undervoltage Lockout (UVLO)

$$R_{UVLO1} = \frac{V_{START} - V_{STOP}}{I_{HYS}} \quad (3)$$

$$R_{UVLO2} = \frac{V_{ENA}}{\frac{V_{START} - V_{ENA}}{R_{UVLO1}} + I_1} \quad (4)$$

7.3.8 Internal Soft Start

The TPS54540-Q1 device has an internal digital soft start that ramps the reference voltage from zero volts to its final value in 1024 switching cycles. The internal soft-start time (10% to 90%) is calculated using Equation 5.

$$t_{SS}(\text{ms}) = \frac{1024}{f_{SW}(\text{kHz})} \quad (5)$$

If the EN pin is pulled below the stop threshold of 1.2 V, switching stops and the internal soft start resets. The soft start also resets in thermal shutdown.

7.3.9 Constant Switching Frequency and Timing Resistor (RT/CLK) Pin)

The switching frequency of the TPS54540-Q1 device is adjustable over a wide range from 100 kHz to 2500 kHz by placing a resistor between the RT/CLK pin and GND pin. The RT/CLK pin voltage is typically 0.5 V, and must have a resistor to ground to set the switching frequency. To determine the timing resistance for a given switching frequency, use Equation 6 or Equation 7 or the curves in Figure 5 and Figure 6. To reduce the solution size one would typically set the switching frequency as high as possible, but tradeoffs of the conversion efficiency, maximum input voltage and minimum controllable on time should be considered. The minimum controllable on time is typically 135 ns, which limits the maximum operating frequency in applications with high input to output step down ratios. The maximum switching frequency is also limited by the frequency foldback circuit. See [Accurate Current Limit](#) for a more detailed discussion of the maximum switching frequency.

$$RT(\text{k}\Omega) = \frac{92417}{f_{sw}(\text{kHz})^{0.991}} \quad (6)$$

$$f_{sw}(\text{kHz}) = \frac{101756}{RT(\text{k}\Omega)^{1.008}} \quad (7)$$

7.3.10 Synchronization to RT/CLK Pin

The RT/CLK pin can receive a frequency synchronization signal from an external system clock. To implement this synchronization feature connect a square wave to the RT/CLK pin through either circuit network shown in Figure 25. The square wave applied to the RT/CLK pin must switch lower than 0.5 V and higher than 1.7 V and have a pulse-width greater than 15 ns. The synchronization frequency range is from 160 kHz to 2300 kHz. The rising edge of the SW will be synchronized to the falling edge of RT/CLK pin signal. The external synchronization

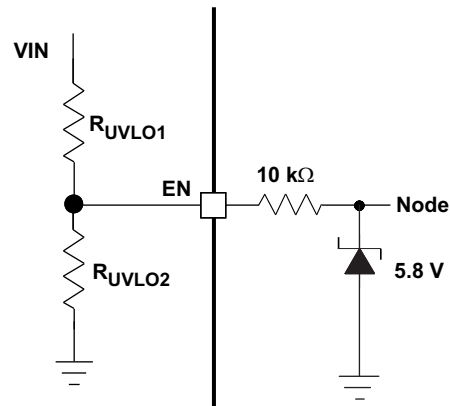

Figure 24. Internal EN Clamp

Feature Description (continued)

circuit should be designed such that the default frequency set resistor is connected from the RT/CLK pin to ground when the synchronization signal is off. When using a low impedance signal source, the frequency set resistor is connected in parallel with an ac coupling capacitor to a termination resistor (for example, 50 Ω) as shown in Figure 25. The two resistors in series provide the default frequency setting resistance when the signal source is turned off. The sum of the resistance should set the switching frequency close to the external CLK frequency. TI recommends ac-coupling the synchronization signal through a 10-pF ceramic capacitor to RT/CLK pin.

The first time the RT/CLK is pulled above the PLL threshold, the TPS54540-Q1 device switches from the RT resistor free-running frequency mode to the PLL synchronized mode. The internal 0.5-V voltage source is removed, and the RT/CLK pin becomes high impedance as the PLL starts to lock onto the external signal. The switching frequency can be higher or lower than the frequency set with the RT/CLK resistor. The device transitions from the resistor mode to the PLL mode, and locks onto the external clock frequency within 78 μs. During the transition from the PLL mode to the resistor programmed mode, the switching frequency will fall to 150 kHz and then increase or decrease to the resistor programmed frequency when the 0.5-V bias voltage is reapplied to the RT/CLK resistor.

The switching frequency is divided by 8, 4, 2, and 1 as the FB pin voltage ramps from 0 V to 0.8 V. The device implements a digital frequency foldback to enable synchronizing to an external clock during normal start-up and fault conditions. Figure 26, Figure 27, and Figure 28 show the device synchronized to an external system clock in continuous conduction mode (CCM), discontinuous conduction (DCM), and pulse skip mode (Eco-mode).

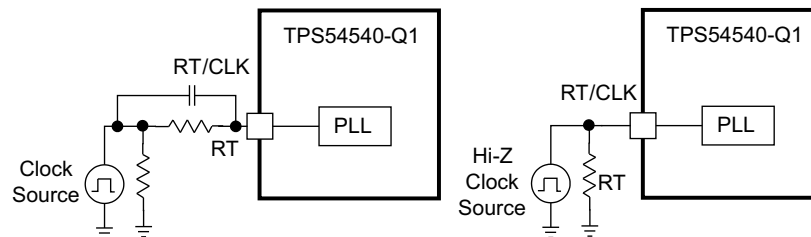

Figure 25. Synchronizing to a System Clock

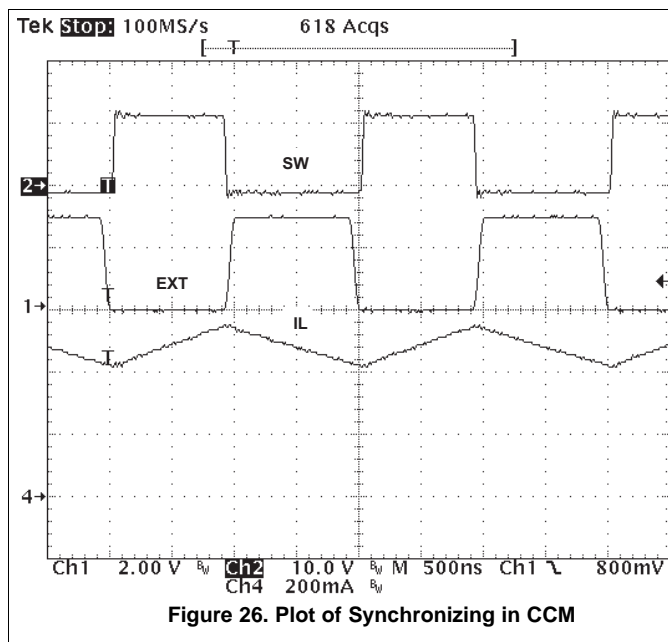

Figure 26. Plot of Synchronizing in CCM

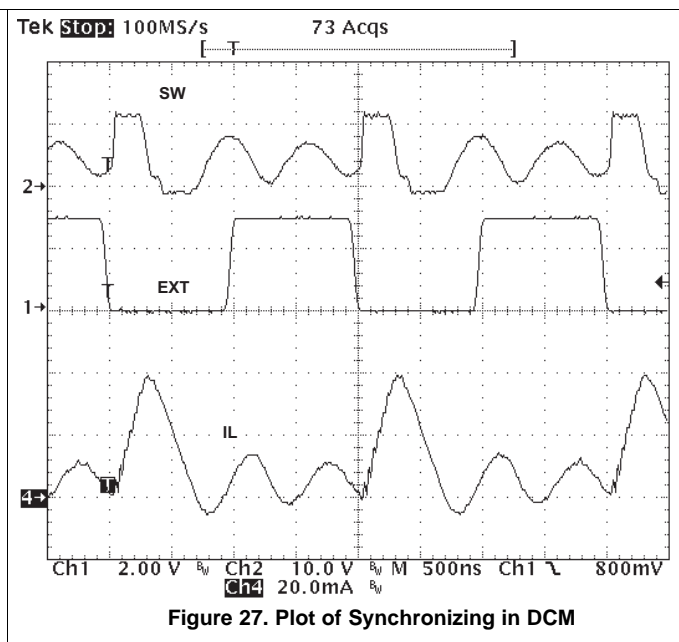
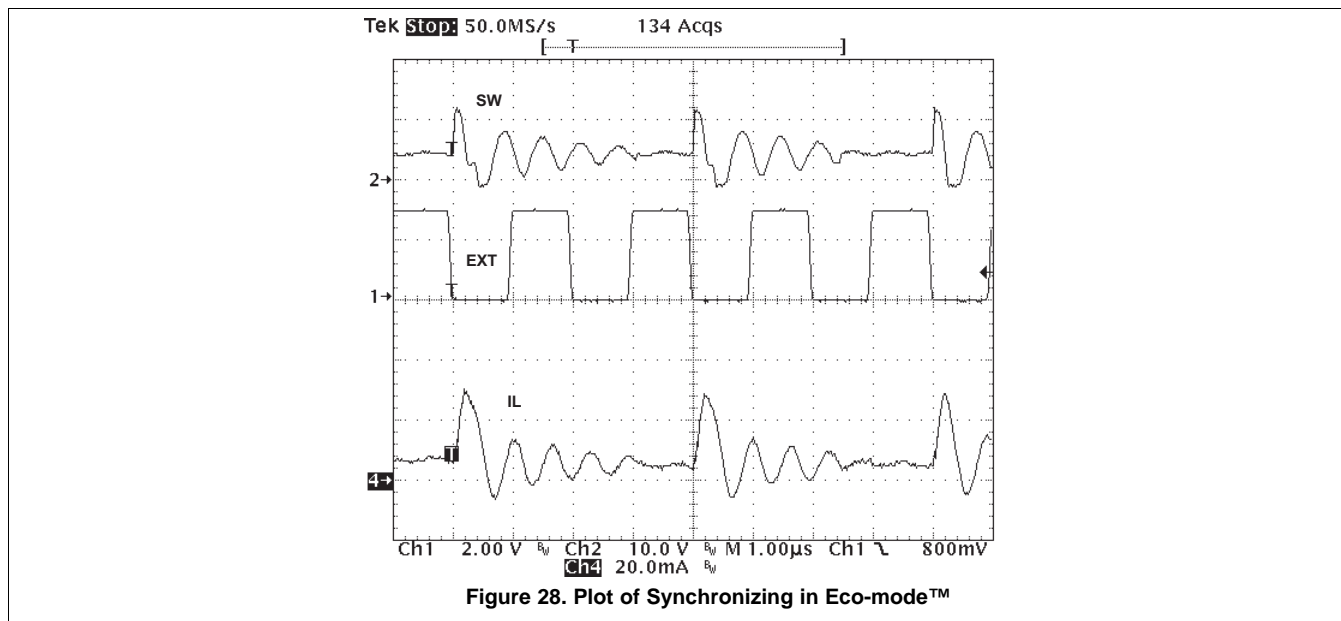

Figure 27. Plot of Synchronizing in DCM

Feature Description (continued)



7.3.11 Maximum Switching Frequency

To protect the converter in overload conditions at higher switching frequencies and input voltages, the TPS54540-Q1 device implements a frequency foldback. The oscillator frequency is divided by 1, 2, 4, and 8 as the FB pin voltage falls from 0.8 V to 0 V. The TPS54540-Q1 device uses a digital frequency foldback to enable synchronization to an external clock during normal start-up and fault conditions. During short circuit events, the inductor current can exceed the peak current limit because of the high input voltage and the minimum controllable on time. When the output voltage is forced low by the shorted load, the inductor current decreases slowly during the switch off time. The frequency foldback effectively increases the off time by increasing the period of the switching cycle providing more time for the inductor current to ramp down.

With a maximum frequency foldback ratio of 8, there is a maximum frequency at which the inductor current can be controlled by frequency foldback protection. Equation 9 calculates the maximum switching frequency at which the inductor current will remain under control when V_{OUT} is forced to $V_{OUT(SC)}$. The selected operating frequency should not exceed the calculated value.

Feature Description (continued)

Equation 8 calculates the maximum switching frequency limitation set by the minimum controllable on time and the input to output step down ratio. Setting the switching frequency above this value will cause the regulator to skip switching pulses to achieve the low duty cycle required at maximum input voltage.

$$f_{SW(\text{max skip})} = \frac{1}{t_{ON}} \times \left(\frac{I_O \times R_{dc} + V_{OUT} + V_d}{V_{IN} - I_O \times R_{DS(on)} + V_d} \right) \quad (8)$$

$$f_{SW(\text{shift})} = \frac{f_{DIV}}{t_{ON}} \times \left(\frac{I_{CL} \times R_{dc} + V_{OUT(sc)} + V_d}{V_{IN} - I_{CL} \times R_{DS(on)} + V_d} \right)$$

where

- I_O = Output current
 - I_{CL} = Current limit
 - R_{dc} = inductor resistance
 - V_{IN} = maximum input voltage
 - V_{OUT} = output voltage
 - V_{OUTSC} = output voltage during short
 - V_d = diode voltage drop
 - $R_{DS(on)}$ = switch on resistance
 - t_{ON} = controllable on time
 - f_{DIV} = frequency divide equals (1, 2, 4, or 8)
- (9)

7.3.12 Accurate Current Limit

The TPS54540-Q1 device implements peak current mode control in which the COMP pin voltage controls the peak current of the high-side MOSFET. A signal proportional to the high-side switch current and the COMP pin voltage are compared each cycle. When the peak switch current intersects the COMP control voltage, the high-side switch is turned off. During overcurrent conditions that pull the output voltage low, the error amplifier increases switch current by driving the COMP pin high. The error amplifier output is clamped internally at a level which sets the peak switch current limit. The TPS54540-Q1 device provides an accurate current limit threshold with a typical current limit delay of 60 ns. With smaller inductor values, the delay will result in a higher peak inductor current. The relationship between the inductor value and the peak inductor current is shown in [Figure 29](#).

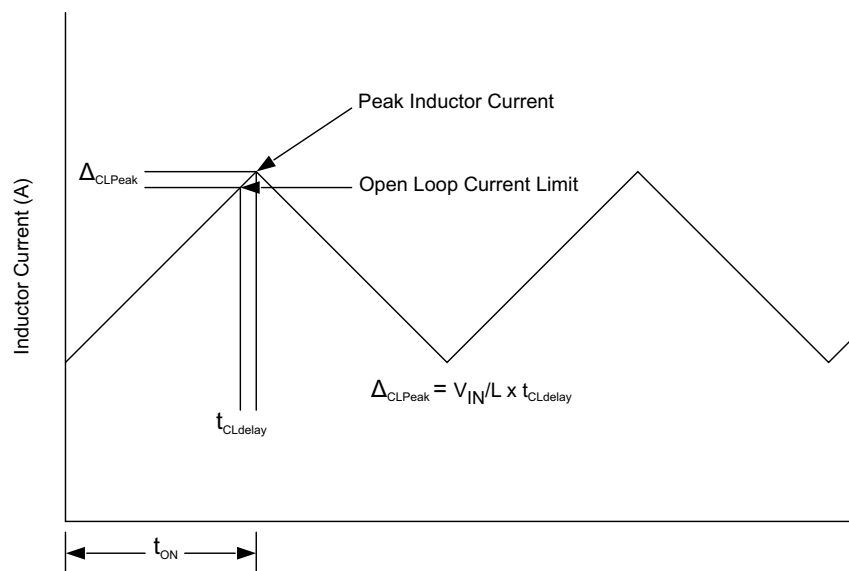

Figure 29. Current Limit Delay

Feature Description (continued)

7.3.13 Overvoltage Protection

The TPS54540-Q1 device incorporates an output overvoltage protection (OVP) circuit to minimize voltage overshoot when recovering from output fault conditions or strong unload transients in designs with low-output capacitance. For example, when the power supply output is overloaded the error amplifier compares the actual output voltage to the internal reference voltage. If the FB pin voltage is lower than the internal reference voltage for a considerable time, the output of the error amplifier will increase to a maximum voltage corresponding to the peak current limit threshold. When the overload condition is removed, the regulator output rises and the error amplifier output transitions to the normal operating level. In some applications, the power supply output voltage can increase faster than the response of the error amplifier output resulting in an output overshoot.

The OVP feature minimizes output overshoot when using a low value output capacitor by comparing the FB pin voltage to the rising OVP threshold which is nominally 109% of the internal voltage reference. If the FB pin voltage is greater than the rising OVP threshold, the high-side MOSFET is immediately disabled to minimize output overshoot. When the FB voltage drops below the falling OVP threshold which is nominally 106% of the internal voltage reference, the high-side MOSFET resumes normal operation.

7.3.14 Thermal Shutdown

The TPS54540-Q1 device provides an internal thermal shutdown to protect the device when the junction temperature exceeds 176°C. The high-side MOSFET stops switching when the junction temperature exceeds the thermal trip threshold. Once the die temperature falls to less than 164°C, the device reinitiates the power-up sequence controlled by the internal soft-start circuitry.

7.3.15 Small Signal Model for Loop Response

Figure 30 shows an equivalent model for the TPS54540-Q1 device control loop, which can be simulated to check the frequency response and dynamic load response. The error amplifier is a transconductance amplifier with a $g_{m_{EA}}$ of 350 $\mu\text{A/V}$. The error amplifier can be modeled using an ideal voltage controlled current source. The resistor R_o and capacitor C_o model the open loop gain and frequency response of the amplifier. The 1-mV AC voltage source between the nodes a and b effectively breaks the control loop for the frequency response measurements. Plotting c/a provides the small signal response of the overall loop. The dynamic loop response can be evaluated by replacing R_L with a current source with the appropriate load step amplitude and step rate in a time domain analysis. This equivalent model is only valid for continuous conduction mode (CCM) operation.

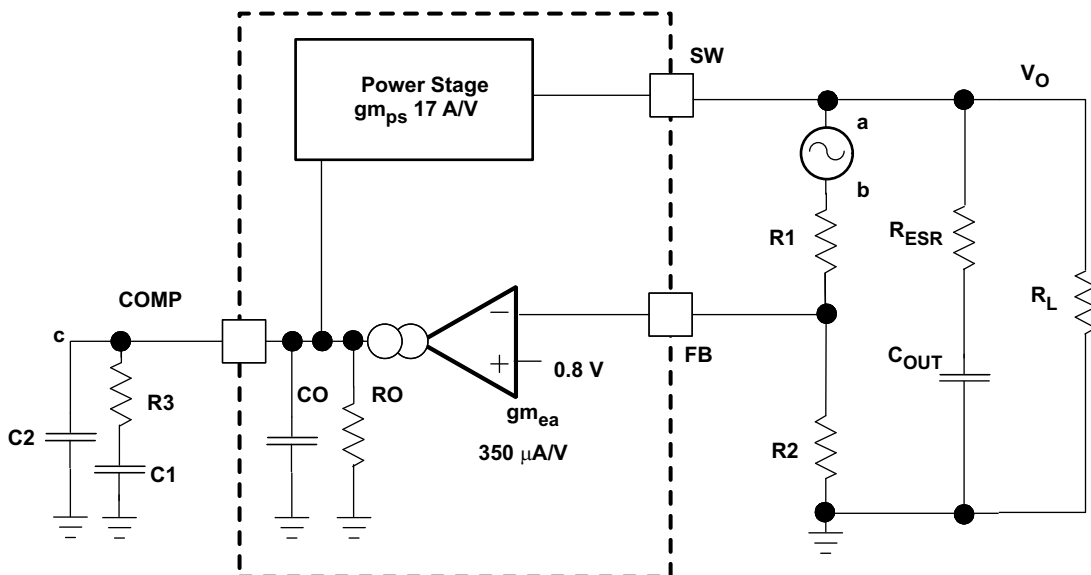

Figure 30. Small Signal Model for Loop Response

Feature Description (continued)

7.3.16 Simple Small Signal Model for Peak Current Mode Control

Figure 31 describes a simple small signal model that can be used to design the frequency compensation. The TPS54540-Q1 power stage can be approximated by a voltage-controlled current source (duty cycle modulator) supplying current to the output capacitor and load resistor. The control to output transfer function is shown in Equation 10 and consists of a DC gain, one dominant pole, and one ESR zero. The quotient of the change in switch current and the change in COMP pin voltage (node c in Figure 30) is the power stage transconductance, gm_{PS} . The gm_{PS} for the TPS54540-Q1 device is 17 A/V. The low-frequency gain of the power stage is the product of the transconductance and the load resistance as shown in Equation 11.

As the load current increases and decreases, the low-frequency gain decreases and increases, respectively. This variation with the load may seem problematic at first glance, but fortunately the dominant pole moves with the load current (see Equation 12). The combined effect is highlighted by the dashed line in the right half of Figure 31. As the load current decreases, the gain increases and the pole frequency lowers, keeping the 0-dB crossover frequency the same with varying load conditions. The type of output capacitor chosen determines whether the ESR zero has a profound effect on the frequency compensation design. Using high ESR aluminum electrolytic capacitors may reduce the number frequency compensation components needed to stabilize the overall loop because the phase margin is increased by the ESR zero of the output capacitor (see Equation 13).

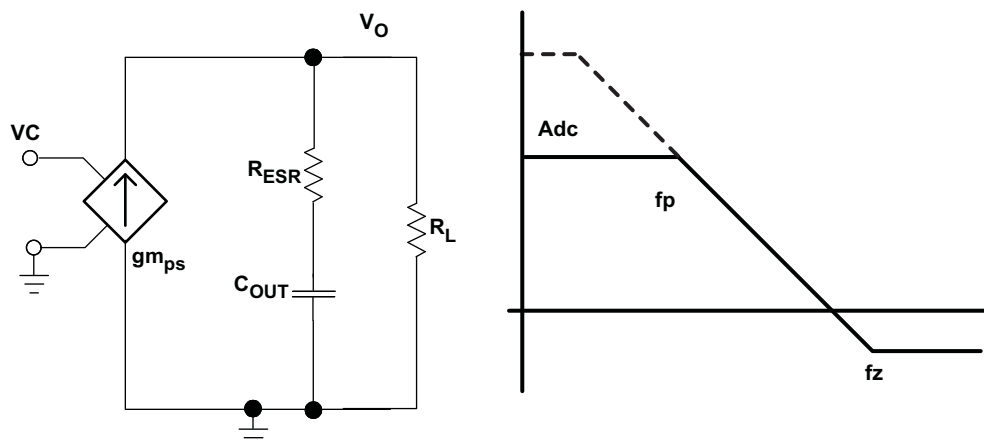

Figure 31. Simple Small Signal Model and Frequency Response for Peak Current Mode Control

$$\frac{V_{OUT}}{V_C} = A_{dc} \times \frac{\left(1 + \frac{s}{2\pi \times f_Z}\right)}{\left(1 + \frac{s}{2\pi \times f_P}\right)} \quad (10)$$

$$A_{dc} = gm_{ps} \times R_L \quad (11)$$

$$f_P = \frac{1}{C_{OUT} \times R_L \times 2\pi} \quad (12)$$

$$f_Z = \frac{1}{C_{OUT} \times R_{ESR} \times 2\pi} \quad (13)$$

Feature Description (continued)

7.3.17 Small Signal Model for Frequency Compensation

The TPS54540-Q1 uses a transconductance amplifier for the error amplifier and supports three of the commonly-used frequency compensation circuits. Compensation circuits Type 2A, Type 2B, and Type 1 are shown in Figure 32. Type 2 circuits are typically implemented in high bandwidth power-supply designs using low ESR output capacitors. The Type 1 circuit is used with power-supply designs with high-ESR aluminum electrolytic or tantalum capacitors. Equation 14 and Equation 15 relate the frequency response of the amplifier to the small signal model in Figure 32. The open-loop gain and bandwidth are modeled using the R_O and C_O shown in Figure 32. See the *Typical Applications* section for a design example using a Type 2A network with a low ESR output capacitor.

Equation 14 through Equation 23 are provided as a reference. An alternative is to use WEBENCH software tools to create a design based on the power supply requirements.

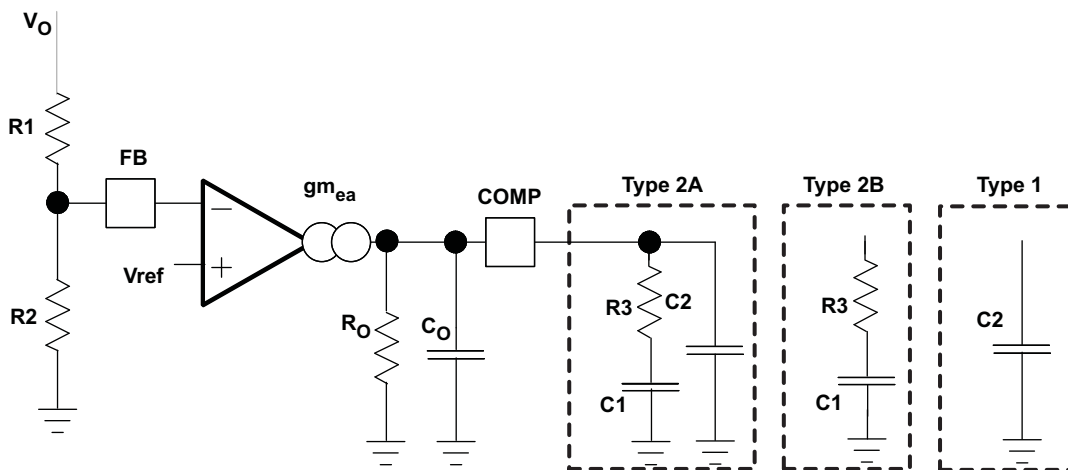

Figure 32. Types of Frequency Compensation

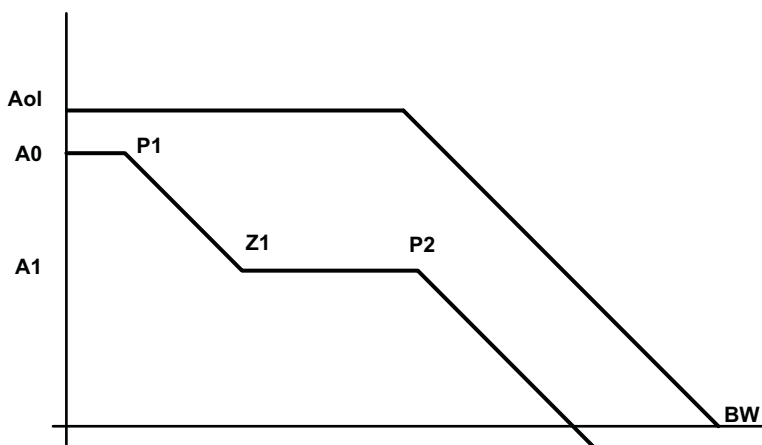

Figure 33. Frequency Response of the Type 2A and Type 2B Frequency Compensation

$$R_O = \frac{A_{ol}(V/V)}{g_{m_{ea}}} \tag{14}$$

$$C_O = \frac{g_{m_{ea}}}{2\pi \times BW \text{ (Hz)}} \tag{15}$$

Feature Description (continued)

$$EA = A0 \times \frac{\left(1 + \frac{s}{2\pi \times f_{Z1}}\right)}{\left(1 + \frac{s}{2\pi \times f_{P1}}\right) \times \left(1 + \frac{s}{2\pi \times f_{P2}}\right)} \quad (16)$$

$$A0 = gm_{ea} \times Ro \times \frac{R2}{R1 + R2} \quad (17)$$

$$A1 = gm_{ea} \times Ro || R3 \times \frac{R2}{R1 + R2} \quad (18)$$

$$P1 = \frac{1}{2\pi \times Ro \times C1} \quad (19)$$

$$Z1 = \frac{1}{2\pi \times R3 \times C1} \quad (20)$$

$$P2 = \frac{1}{2\pi \times R3 || R_O \times (C2 + C_O)} \text{ type 2a} \quad (21)$$

$$P2 = \frac{1}{2\pi \times R3 || R_O \times C_O} \text{ type 2b} \quad (22)$$

$$P2 = \frac{1}{2\pi \times R_O \times (C2 + C_O)} \text{ type 1} \quad (23)$$

7.4 Device Functional Modes

The TPS54540-Q1 device is designed to operate with input voltages greater than 4.5 V. When the VIN voltage is greater than the 4.3 V typical rising UVLO threshold and the EN voltage is above the 1.2 V typical threshold the device is active. If the VIN voltage falls below the typical 4-V UVLO turnoff threshold, the device stops switching. If the EN voltage falls below the 1.2-V threshold the device stops switching and enters a shutdown mode with low supply current of 2 μA typical.

The TPS54540-Q1 device operates in CCM when the output current is enough to keep the inductor current greater than 0 A at the end of each switching period. As a nonsynchronous converter, it will enter DCM at low-output currents when the inductor current falls to 0 A before the end of a switching period. At very low-output current the COMP voltage will drop to the pulse-skipping threshold and the device operates in a pulse-skipping Eco-mode. In this mode, the high-side MOSFET does not switch every switching period. This operating mode reduces power loss while keeping the output voltage regulated. For more information on Eco-mode, see the [Pulse-Skip Eco-mode](#) section.

8 Application and Implementation

NOTE

Information in the following applications sections is not part of the TI component specification, and TI does not warrant its accuracy or completeness. TI's customers are responsible for determining suitability of components for their purposes. Customers should validate and test their design implementation to confirm system functionality.

8.1 Application Information

The TPS54540-Q1 device is a 42-V, 5-A, step-down regulator with an integrated high-side MOSFET. This device is typically used to convert a higher DC voltage to a lower DC voltage with a maximum available output current of 5 A. Example applications are: 12-V and 24-V industrial, automotive, and communications power systems. Use the following design procedure to select component values for the TPS54540-Q1 device. This procedure illustrates the design of a high-frequency switching regulator using ceramic output capacitors. Calculations can be done with the excel spreadsheet (SLVC452) located on the product page. Alternately, use the WEBENCH software to generate a complete design. The WEBENCH software uses an iterative design procedure and accesses a comprehensive database of components when generating a design. This section presents a simplified discussion of the design process.

8.2 Typical Applications

8.2.1 Buck Converter With 6-V to 42-V Input and 3.3-V at 5-A Output

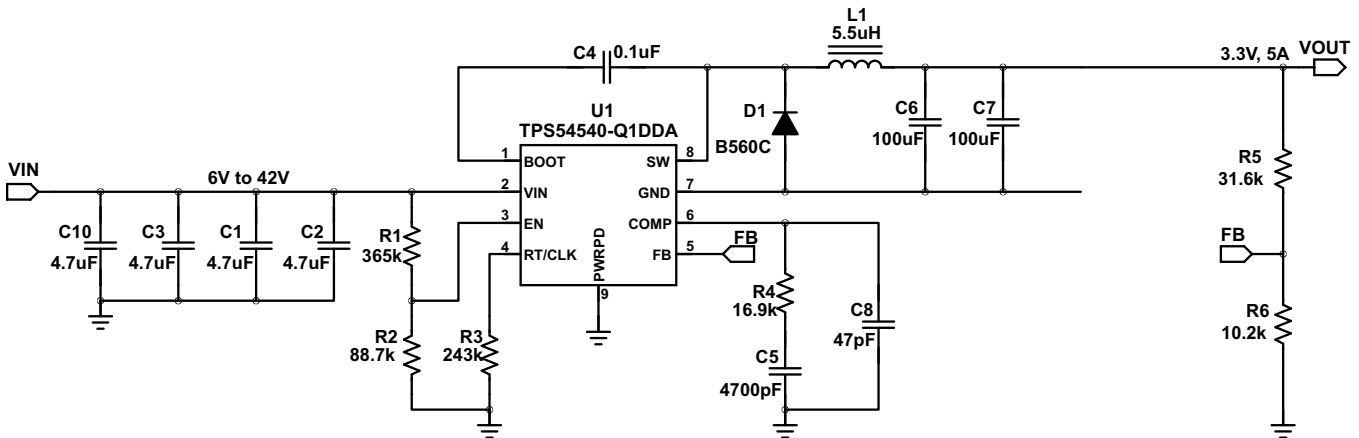

Figure 34. 3.3-V Output TPS54540 Design Example

8.2.1.1 Design Requirements

This guide illustrates the design of a high-frequency switching regulator using ceramic output capacitors. A few parameters must be known to start the design process. These requirements are typically determined at the system level. This example in Figure 34 is designed with the known parameters listed in Table 1.

Table 1. Design Parameters

DESIGN PARAMETERS	EXAMPLE VALUE
Output Voltage	3.3 V
Transient Response 1.25-A to 3.75-A load step	$\Delta V_{OUT} = 4\%$
Maximum Output Current	5 A
Input Voltage	12 V nom. 6 V to 42 V
Output Voltage Ripple	0.5% of V_{OUT}
Start Input Voltage (rising VIN)	5.75 V
Stop Input Voltage (falling VIN)	4.5 V

8.2.1.2 Detailed Design Procedure

8.2.1.2.1 Selecting the Switching Frequency

The first step is to choose a switching frequency for the regulator. Typically, the designer uses the highest switching frequency possible because this produces the smallest solution size. High switching frequency allows for lower value inductors and smaller output capacitors compared to a power supply that switches at a lower frequency. The switching frequency that can be selected is limited by the minimum on-time of the internal power switch, the input voltage, the output voltage and the frequency foldback protection.

Equation 8 and Equation 9 should be used to calculate the upper limit of the switching frequency for the regulator (see Equation 24 and Equation 25). Choose the lower value result from the two equations. Switching frequencies higher than these values results in pulse skipping or the lack of overcurrent protection during a short circuit.

The typical minimum on time, t_{onmin} , is 135 ns for the TPS54540-Q1 device. Equation 8 and Equation 9 should be used to calculate the upper limit of the switching for the regulator (see Equation 24 and Equation 25). For this example, the output voltage is 3.3 V and the maximum input voltage is 42 V. Assuming a diode voltage of 0.52 V, inductor DC resistance of 10.3 mΩ, typical switch resistance of 92-mΩ and 5-A load, from Equation 8 the maximum switch frequency to avoid pulse skipping is 680 kHz. To ensure overcurrent runaway is not a concern during short circuits use Equation 9 to determine the maximum switching frequency for frequency foldback protection. With a current limit value of 6.3 A and short circuit output voltage of 0.1 V, the maximum switching frequency is 960 kHz.

For this design, a lower switching frequency of 400 kHz is chosen to operate comfortably below the calculated maximums. To determine the timing resistance for a given switching frequency, use Equation 6 or the curve in Equation 6. The switching frequency is set by resistor R_3 shown in Figure 34. For 400-kHz operation, the closest standard value resistor is 243 kΩ (see Equation 26).

$$f_{SW(max\ skip)} = \frac{1}{135ns} \times \left(\frac{5\ A \times 10.3\ m\Omega + 3.3\ V + 0.52\ V}{42\ V - 5\ A \times 92\ m\Omega + 0.52\ V} \right) = 680\ kHz \quad (24)$$

$$f_{SW(shift)} = \frac{8}{135\ ns} \times \left(\frac{6.3\ A \times 10.3\ m\Omega + 0.1\ V + 0.52\ V}{42\ V - 6.3\ A \times 92\ m\Omega + 0.52\ V} \right) = 960\ kHz \quad (25)$$

$$RT\ (k\Omega) = \frac{92417}{400\ (kHz)^{0.991}} = 244\ k\Omega \quad (26)$$

8.2.1.2.2 Output Inductor Selection (L_o)

To calculate the minimum value of the output inductor, use Equation 27.

K_{IND} is a ratio that represents the amount of inductor ripple current relative to the maximum output current. The inductor ripple current is filtered by the output capacitor. Therefore, choosing high inductor ripple currents impacts the selection of the output capacitor because the output capacitor must have a ripple current rating equal to or greater than the inductor ripple current. In general, the inductor ripple value is at the discretion of the designer, however, the following guidelines may be used.

For designs using low ESR output capacitors such as ceramics, a value as high as $K_{IND} = 0.3$ may be desirable. When using higher ESR output capacitors, $K_{IND} = 0.2$ yields better results. Because the inductor ripple current is part of the current mode PWM control system, the inductor ripple current should always be greater than 150 mA for stable PWM operation. In a wide input voltage regulator, it is best to choose relatively large inductor ripple current. This provides sufficient ripple current with the input voltage at the minimum.

For this design example, $K_{IND} = 0.3$ and the inductor value is calculated to be 5.1 μH. It is important that the RMS current and saturation current ratings of the inductor not be exceeded. The RMS and peak inductor current can be found from Equation 29 and Equation 30 (using Equation 28). For this design, the RMS inductor current is 5 A and the peak inductor current is 5.79 A. The chosen inductor is a WE 744325550, which has a saturation current rating of 12 A and an RMS current rating of 10 A. This conductor also has a typical inductance of 5.5 μH at no load and 4.8 μH at a 5-A load. Lastly, the chosen conductor has a DCR of 10.3 mΩ.

As the equation set demonstrates, lower ripple currents will reduce the output voltage ripple of the regulator but will require a larger value of inductance. Selecting higher ripple currents will increase the output voltage ripple of the regulator but allow for a lower inductance value.

The current flowing through the inductor is the inductor ripple current plus the output current. During power-up, faults or transient load conditions, the inductor current can increase above the peak inductor current level calculated previously. In transient conditions, the inductor current can increase up to the switch current limit of the device. For this reason, the most conservative design approach is to choose an inductor with a saturation current rating equal to or greater than the switch current limit of the TPS54540 device, which is nominally 7.5 A.

$$L_{O(\min)} = \frac{V_{IN(\max)} - V_{OUT}}{I_{OUT} \times K_{IND}} \times \frac{V_{OUT}}{V_{IN(\max)} \times f_{SW}} = \frac{42 \text{ V} - 3.3 \text{ V}}{5 \text{ A} \times 0.3} \times \frac{3.3 \text{ V}}{42 \text{ V} \times 400 \text{ kHz}} = 5.1 \mu\text{H} \quad (27)$$

$$I_{RIPPLE} = \frac{V_{OUT} \times (V_{IN(\max)} - V_{OUT})}{V_{IN(\max)} \times L_O \times f_{SW}} = \frac{3.3 \text{ V} \times (42 \text{ V} - 3.3 \text{ V})}{42 \text{ V} \times 4.8 \mu\text{H} \times 400 \text{ kHz}} = 1.58 \text{ A} \quad (28)$$

$$I_{L(\text{rms})} = \sqrt{(I_{OUT})^2 + \frac{1}{12} \times \left(\frac{V_{OUT} \times (V_{IN(\max)} - V_{OUT})}{V_{IN(\max)} \times L_O \times f_{SW}} \right)^2} = \sqrt{(5 \text{ A})^2 + \frac{1}{12} \times \left(\frac{3.3 \text{ V} \times (42 \text{ V} - 3.3 \text{ V})}{42 \text{ V} \times 4.8 \mu\text{H} \times 400 \text{ kHz}} \right)^2} = 5 \text{ A} \quad (29)$$

$$I_{L(\text{peak})} = I_{OUT} + \frac{I_{RIPPLE}}{2} = 5 \text{ A} + \frac{1.58 \text{ A}}{2} = 5.79 \text{ A} \quad (30)$$

8.2.1.2.3 Output Capacitor

There are three primary considerations for selecting the value of the output capacitor. The output capacitor determines the modulator pole, the output voltage ripple, and how the regulator responds to a large change in load current. The output capacitance must be selected based on the most stringent of these three criteria.

The desired response to a large change in the load current is the first criteria. The output capacitor needs to supply the increased load current until the regulator responds to the load step. A regulator does not respond immediately to a large, fast increase in the load current such as transitioning from no load to a full load. The regulator usually needs two or more clock cycles for the control loop to sense the change in output voltage and adjust the peak switch current in response to the higher load. The output capacitance must be large enough to supply the difference in current for 2 clock cycles to maintain the output voltage within the specified range. Equation 31 shows the minimum output capacitance necessary, where ΔI_{OUT} is the change in output current, f_{sw} is the regulators switching frequency and ΔV_{OUT} is the allowable change in the output voltage. For this example, the transient load response is specified as a 4% change in V_{OUT} for a load step from 1.25 A to 3.75 A. Therefore, ΔI_{OUT} is 3.75 A – 1.25 A = 2.5 A and $\Delta V_{OUT} = 0.04 \times 3.3 \text{ V} = 0.13 \text{ V}$. Using these numbers gives a minimum capacitance of 95 μF . This value does not take the ESR of the output capacitor into account in the output voltage change. For ceramic capacitors, the ESR is usually small enough to be ignored. Aluminum electrolytic and tantalum capacitors have higher ESR that must be included in load step calculations.

The output capacitor must also be sized to absorb energy stored in the inductor when transitioning from a high to low load current. The catch diode of the regulator can not sink current so energy stored in the inductor can produce an output voltage overshoot when the load current rapidly decreases. A typical load step response is shown in Figure 39. The excess energy absorbed in the output capacitor will increase the voltage on the capacitor. The capacitor must be sized to maintain the desired output voltage during these transient periods. Equation 32 calculates the minimum capacitance required to keep the output voltage overshoot to a desired value, where L_O is the value of the inductor, I_{OH} is the output current under heavy load, I_{OL} is the output under light load, V_f is the peak output voltage, and V_i is the initial voltage. For this example, the worst case load step will be from 3.75 A to 1.25 A. The output voltage increases during this load transition and the stated maximum in our specification is 4 % of the output voltage. This makes $V_f = 1.04 \times 3.3 \text{ V} = 3.43 \text{ V}$. V_i is the initial capacitor voltage that is the nominal output voltage of 3.3 V. Using these numbers in Equation 32 yields a minimum capacitance of 68 μF .

Equation 33 calculates the minimum output capacitance needed to meet the output voltage ripple specification, where f_{SW} is the switching frequency, $V_{ORIPPLE}$ is the maximum allowable output voltage ripple, and I_{RIPPLE} is the inductor ripple current. **Equation 33** yields 30 μF .

Equation 34 calculates the maximum ESR an output capacitor must meet the output voltage ripple specification. **Equation 34** indicates the equivalent ESR should be less than 10 $\text{m}\Omega$.

The most stringent criteria for the output capacitor is 95 μF required to maintain the output voltage within regulation tolerance during a load transient.

Capacitance deratings for aging, temperature and Eco-mode bias increases this minimum value. For this example, 2 \times 100- μF , 6.3-V type X5R ceramic capacitors with 2 $\text{m}\Omega$ of ESR will be used. The derated capacitance is 130 μF , well above the minimum required capacitance of 95 μF .

Capacitors are generally rated for a maximum ripple current that can be filtered without degrading capacitor reliability, especially non ceramic capacitors. Some capacitor data sheets specify the root mean square (RMS) value of the maximum ripple current. **Equation 35** can be used to calculate the RMS ripple current that the output capacitor must support. For this example, **Equation 35** yields 460 mA.

$$C_{OUT} > \frac{2 \times \Delta I_{OUT}}{f_{SW} \times \Delta V_{OUT}} = \frac{2 \times 2.5 \text{ A}}{400 \text{ kHz} \times 0.13 \text{ V}} = 95 \mu\text{F} \quad (31)$$

$$C_{OUT} > L_O \times \frac{\left((I_{OH})^2 - (I_{OL})^2 \right)}{\left((V_f)^2 - (V_l)^2 \right)} = 4.8 \mu\text{H} \times \frac{\left(3.75 \text{ A}^2 - 1.25 \text{ A}^2 \right)}{\left(3.43 \text{ V}^2 - 3.3 \text{ V}^2 \right)} = 68 \mu\text{F} \quad (32)$$

$$C_{OUT} > \frac{1}{8 \times f_{SW}} \times \frac{1}{\left(\frac{V_{ORIPPLE}}{I_{RIPPLE}} \right)} = \frac{1}{8 \times 400 \text{ kHz}} \times \frac{1}{\left(\frac{16 \text{ mV}}{1.58 \text{ A}} \right)} = 30 \mu\text{F} \quad (33)$$

$$R_{ESR} < \frac{V_{ORIPPLE}}{I_{RIPPLE}} = \frac{16 \text{ mV}}{1.58 \text{ A}} = 10 \text{ m}\Omega \quad (34)$$

$$I_{COUT(rms)} = \frac{V_{OUT} \times \left(V_{IN(max)} - V_{OUT} \right)}{\sqrt{12} \times V_{IN(max)} \times L_O \times f_{SW}} = \frac{3.3 \text{ V} \times (42 \text{ V} - 3.3 \text{ V})}{\sqrt{12} \times 42 \text{ V} \times 4.8 \mu\text{H} \times 400 \text{ kHz}} = 460 \text{ mA} \quad (35)$$

8.2.1.2.4 Catch Diode

The TPS54540 device requires an external catch diode between the SW pin and GND. The selected diode must have a reverse voltage rating equal to or greater than $V_{IN(max)}$. The peak current rating of the diode must be greater than the maximum inductor current. Schottky diodes are typically a good choice for the catch diode due to their low forward voltage. The lower the forward voltage of the diode, the higher the efficiency of the regulator.

Typically, diodes with higher voltage and current ratings have higher forward voltages. A diode with a minimum of 42-V reverse voltage is preferred to allow input voltage transients up to the rated voltage of the TPS54540-Q1 device.

For the example design, the PDS760-13 Schottky diode is selected for its lower forward voltage and good thermal characteristics compared to smaller devices. The typical forward voltage of the PDS760-13 is 0.52 V at 5 A and 25°C.

The diode must also be selected with an appropriate power rating. The diode conducts the output current during the off-time of the internal power switch. The off-time of the internal switch is a function of the maximum input voltage, the output voltage, and the switching frequency. The output current during the off-time is multiplied by the forward voltage of the diode to calculate the instantaneous conduction losses of the diode. At higher switching frequencies, the AC losses of the diode must be taken into account. The AC losses of the diode are due to the charging and discharging of the junction capacitance and reverse recovery charge. **Equation 36** is used to calculate the total power dissipation, including conduction losses and AC losses of the diode.

The PDS760-13 diode has a junction capacitance of 300 pF. Using **Equation 36**, the total loss in the diode at the nominal input voltage is 1.9 W.

If the power supply spends a significant amount of time at light load currents or in sleep mode, consider using a diode, which has a low leakage current and slightly higher forward voltage drop.

$$P_D = \frac{(V_{IN(max)} - V_{OUT}) \times I_{OUT} \times V_{fd}}{V_{IN}} + \frac{C_j \times f_{SW} \times (V_{IN} + V_{fd})^2}{2} =$$

$$\frac{(12\text{ V} - 3.3\text{ V}) \times 5\text{ A} \times 0.52\text{ V}}{12\text{ V}} + \frac{300\text{ pF} \times 400\text{ kHz} \times (12\text{ V} + 0.52\text{ V})^2}{2} = 1.9\text{ W} \quad (36)$$

8.2.1.2.5 Input Capacitor

The TPS54540-Q1 device requires a high quality ceramic type X5R or X7R input decoupling capacitor with at least 3 μF of effective capacitance. Some applications will benefit from additional bulk capacitance. The effective capacitance includes any loss of capacitance due to DC bias effects. The voltage rating of the input capacitor must be greater than the maximum input voltage. The capacitor must also have a ripple current rating greater than the maximum input current ripple of the TPS54540-Q1 device. The input ripple current can be calculated using [Equation 37](#).

The value of a ceramic capacitor varies significantly with temperature and the Eco-mode bias applied to the capacitor. The capacitance variations due to temperature can be minimized by selecting a dielectric material that is more stable over temperature. X5R and X7R ceramic dielectrics are usually selected for switching regulator capacitors because they have a high capacitance to volume ratio and are fairly stable over temperature. The input capacitor must also be selected with consideration for the DC bias. The effective value of a capacitor decreases as the DC bias across a capacitor increases.

For this example design, a ceramic capacitor with at least a 42-V voltage rating is required to support transients up to the maximum input voltage. Common standard ceramic capacitor voltage ratings include 4 V, 6.3 V, 10 V, 16 V, 25 V, 50 V or 100 V. For this example, four 4.7- μF , 50-V capacitors in parallel are used. [Table 2](#) lists several choices of high voltage capacitors.

The input capacitance value determines the input ripple voltage of the regulator. The maximum input voltage ripple occurs at 50% duty cycle and can be calculated using [Equation 38](#). Using the design example values, $I_{OUT} = 5\text{ A}$, $C_{IN} = 18.8\text{ }\mu\text{F}$, $f_{sw} = 400\text{ kHz}$, yields an input voltage ripple of 170 mV and a rms input ripple current of 2.5 A.

$$I_{CI(rms)} = I_{OUT} \times \sqrt{\frac{V_{OUT}}{V_{IN(min)}} \times \frac{(V_{IN(min)} - V_{OUT})}{V_{IN(min)}}} = 5\text{ A} \times \sqrt{\frac{3.3\text{ V}}{6\text{ V}} \times \frac{(6\text{ V} - 3.3\text{ V})}{6\text{ V}}} = 2.5\text{ A} \quad (37)$$

$$\Delta V_{IN} = \frac{I_{OUT} \times 0.25}{C_{IN} \times f_{SW}} = \frac{5\text{ A} \times 0.25}{18.8\text{ }\mu\text{F} \times 400\text{ kHz}} = 170\text{ mV} \quad (38)$$

Table 2. Capacitor Types

VENDOR	VALUE (μF)	EIA SIZE	VOLTAGE	DIELECTRIC	COMMENTS	
Murata	1 to 2.2	1210	100 V	X7R	GRM32 series	
	1 to 4.7		50 V			
	1	1206	100 V		GRM31 series	
	1 to 2.2		50 V			
Vishay	1 to 1.8	2220	50 V		VJ X7R series	
	1 to 1.2		100 V			
	1 to 3.9	2225	50 V			
	1 to 1.8		100 V			
TDK	1 to 2.2	1812	100 V			C series C4532
	1.5 to 6.8		50 V			
	1 to 2.2	1210	100 V			C series C3225
	1 to 3.3		50 V			
AVX	1 to 4.7	1210	50 V		X7R dielectric series	
	1		100 V			
	1 to 4.7	1812	50 V			
	1 to 2.2		100 V			

8.2.1.2.6 Bootstrap Capacitor Selection

A 0.1-μF ceramic capacitor must be connected between the BOOT and SW pins for proper operation. A ceramic capacitor with X5R or better grade dielectric is recommended. The capacitor should have a 10-V or higher voltage rating.

8.2.1.2.7 Undervoltage Lockout Set Point

The undervoltage lockout (UVLO) can be adjusted using an external voltage divider on the EN pin of the TPS54540-Q1 device. The UVLO has two thresholds, one for power-up when the input voltage is rising and one for power-down or brown outs when the input voltage is falling. For the example design, the supply should turn on and start switching once the input voltage is greater than 5.75 V (UVLO start). After the regulator starts switching, it should continue to do so until the input voltage falls below 4.5 V (UVLO stop).

Programmable UVLO threshold voltages are set using the resistor divider of R_{UVLO1} and R_{UVLO2} between V_{IN} and ground connected to the EN pin. Equation 3 and Equation 4 calculate the resistance values necessary. For the example application, a 365 kΩ between V_{IN} and EN (R_{UVLO1}) and a 88.7 kΩ between EN and ground (R_{UVLO2}) are required to produce the 5.75-V and 4.5-V start and stop voltages.

$$R_{UVLO1} = \frac{V_{START} - V_{STOP}}{I_{HYS}} = \frac{5.75 \text{ V} - 4.5 \text{ V}}{3.4 \mu\text{A}} = 368 \text{ k}\Omega \quad (39)$$

$$R_{UVLO2} = \frac{V_{ENA}}{\frac{V_{START} - V_{ENA}}{R_{UVLO1}} + I_1} = \frac{1.2 \text{ V}}{\frac{5.75 \text{ V} - 1.2 \text{ V}}{365 \text{ k}\Omega} + 1.2 \mu\text{A}} = 88.7 \text{ k}\Omega \quad (40)$$

8.2.1.2.8 Output Voltage and Feedback Resistors Selection

The voltage divider of R_5 and R_6 sets the output voltage. For the example design, 10.2 kΩ was selected for R_6 . Using Equation 2, R_5 is calculated as 31.9 kΩ. The nearest standard 1% resistor is 31.6 kΩ. Due to the input current of the FB pin, the current flowing through the feedback network should be greater than 1 μA to maintain the output voltage accuracy. This requirement is satisfied if the value of R_6 is less than 800 kΩ. Choosing higher resistor values decreases quiescent current and improves efficiency at low-output currents but may also introduce noise immunity problems. For more details about adjusting the output voltage, see Equation 41.

$$R_{HS} = R_{LS} \times \frac{V_{OUT} - 0.8 \text{ V}}{0.8 \text{ V}} = 10.2 \text{ k}\Omega \times \left(\frac{3.3 \text{ V} - 0.8 \text{ V}}{0.8 \text{ V}} \right) = 31.9 \text{ k}\Omega \quad (41)$$

8.2.1.2.9 Compensation

There are several methods to design compensation for DC-DC regulators. The method presented here is easy to calculate and ignores the effects of the slope compensation that is internal to the device. Because the slope compensation is ignored, the actual crossover frequency will be lower than the crossover frequency used in the calculations. This method assumes the crossover frequency is between the modulator pole and the ESR zero and the ESR zero is at least 10 times greater the modulator pole.

To get started, the modulator pole, $f_{p(mod)}$, and the ESR zero, f_{z1} must be calculated using [Equation 42](#) and [Equation 43](#). For C_{OUT} , use a derated value of 130 μF . Use equations [Equation 44](#) and [Equation 45](#) to estimate a starting point for the crossover frequency, f_{co} . For the example design, $f_{p(mod)}$ is 1850 Hz and $f_{z(mod)}$ is 610 kHz. [Equation 43](#) is the geometric mean of the modulator pole and the ESR zero and [Equation 45](#) is the mean of modulator pole and half of the switching frequency. [Equation 44](#) yields 34 kHz and [Equation 45](#) gives 19 kHz. Use the geometric mean value of [Equation 44](#) and [Equation 45](#) for an initial crossover frequency. For this example, after lab measurement, the crossover frequency target was increased to 30 kHz for an improved transient response.

Next, the compensation components are calculated. A resistor in series with a capacitor is used to create a compensating zero. A capacitor in parallel to these two components forms the compensating pole.

$$f_{p(mod)} = \frac{I_{OUT(max)}}{2 \times \pi \times V_{OUT} \times C_{OUT}} = \frac{5 \text{ A}}{2 \times \pi \times 3.3 \text{ V} \times 130 \mu\text{F}} = 1850 \text{ Hz} \quad (42)$$

$$f_{z(mod)} = \frac{1}{2 \times \pi \times R_{ESR} \times C_{OUT}} = \frac{1}{2 \times \pi \times 1 \text{ m}\Omega \times 130 \mu\text{F}} = 610 \text{ kHz} \quad (43)$$

$$f_{co1} = \sqrt{f_{p(mod)} \times f_{z(mod)}} = \sqrt{1850 \text{ Hz} \times 610 \text{ kHz}} = 34 \text{ kHz} \quad (44)$$

$$f_{co2} = \sqrt{f_{p(mod)} \times \frac{f_{sw}}{2}} = \sqrt{1850 \text{ Hz} \times \frac{400 \text{ kHz}}{2}} = 19 \text{ kHz} \quad (45)$$

To determine the compensation resistor, R4, use [Equation 46](#). The typical power stage transconductance, g_{mps} , is 17 A/V. The output voltage, V_O , reference voltage, V_{REF} , and amplifier transconductance, g_{mea} , are 3.3 V, 0.8 V and 350 $\mu\text{A/V}$, respectively. R4 is calculated to be 17 k Ω and a standard value of 16.9 k Ω is selected. Use [Equation 47](#) to set the compensation zero to the modulator pole frequency. [Equation 47](#) yields 5100 pF for compensating capacitor C5. 4700 pF is used for this design.

$$R4 = \left(\frac{2 \times \pi \times f_{co} \times C_{OUT}}{g_{mps}} \right) \times \left(\frac{V_{OUT}}{V_{REF} \times g_{mea}} \right) = \left(\frac{2 \times \pi \times 30 \text{ kHz} \times 130 \mu\text{F}}{17 \text{ A/V}} \right) \times \left(\frac{3.3 \text{ V}}{0.8 \text{ V} \times 350 \mu\text{A/V}} \right) = 17 \text{ k}\Omega \quad (46)$$

$$C5 = \frac{1}{2 \times \pi \times R4 \times f_{p(mod)}} = \frac{1}{2 \times \pi \times 16.9 \text{ k}\Omega \times 1850 \text{ Hz}} = 5100 \text{ pF} \quad (47)$$

A compensation pole can be implemented if desired by adding capacitor C8 in parallel with the series combination of R4 and C5. Use the larger value calculated from [Equation 48](#) and [Equation 49](#) for C8 to set the compensation pole. The selected value of C8 is 47 pF for this design example.

$$C8 = \frac{C_{OUT} \times R_{ESR}}{R4} = \frac{130 \mu\text{F} \times 1 \text{ m}\Omega}{16.9 \text{ k}\Omega} = 15 \text{ pF} \quad (48)$$

$$C8 = \frac{1}{R4 \times f_{sw} \times \pi} = \frac{1}{16.9 \text{ k}\Omega \times 400 \text{ kHz} \times \pi} = 47 \text{ pF} \quad (49)$$

8.2.1.2.10 Power Dissipation Estimate

The formulas in [Equation 50](#) and [Equation 56](#) show how to estimate the TPS54540-Q1 power dissipation under continuous conduction mode (CCM) operation. These equations should not be used if the device is operating in discontinuous conduction mode (DCM).

The power dissipation of the IC includes conduction loss (P_{COND}), switching loss (P_{SW}), gate drive loss (P_{GD}) and supply current (P_Q). Example calculations are shown with the 12-V typical input voltage of the design example.

$$P_{COND} = (I_{OUT})^2 \times R_{DS(on)} \times \left(\frac{V_{OUT}}{V_{IN}} \right) = 5 \text{ A}^2 \times 92 \text{ m}\Omega \times \frac{5 \text{ V}}{12 \text{ V}} = 0.958 \text{ W} \quad (50)$$

$$P_{SW} = V_{IN} \times f_{SW} \times I_{OUT} \times t_{rise} = 12 \text{ V} \times 400 \text{ kHz} \times 5 \text{ A} \times 4.9 \text{ ns} = 0.118 \text{ W} \quad (51)$$

$$P_{GD} = V_{IN} \times Q_G \times f_{SW} = 12 \text{ V} \times 3\text{nC} \times 400 \text{ kHz} = 0.014 \text{ W} \quad (52)$$

$$P_Q = V_{IN} \times I_Q = 12 \text{ V} \times 146 \text{ }\mu\text{A} = 0.0018 \text{ W}$$

where

- I_{OUT} is the output current (A)
- $R_{DS(on)}$ is the on-resistance of the high-side MOSFET (Ω)
- V_{OUT} is the output voltage (V)
- V_{IN} is the input voltage (V)
- f_{sw} is the switching frequency (Hz)
- t_{rise} is the SW pin voltage rise time and can be estimated by $t_{rise} = V_{IN} \times 0.16 \text{ ns/V} + 3 \text{ ns}$
- Q_G is the total gate charge of the internal MOSFET
- I_Q is the operating nonswitching supply current

Therefore,

$$P_{TOT} = P_{COND} + P_{SW} + P_{GD} + P_Q = 0.958 \text{ W} + 0.118 \text{ W} + 0.014 \text{ W} + 0.0018 \text{ W} = 1.092 \text{ W} \quad (54)$$

For given T_A ,

$$T_J = T_A + R_{TH} \times P_{TOT} \quad (55)$$

For given $T_{JMAX} = 150^\circ\text{C}$

$$T_{A(max)} = T_{J(max)} - R_{TH} \times P_{TOT}$$

where

- P_{tot} is the total device power dissipation (W)
- T_A is the ambient temperature ($^\circ\text{C}$)
- T_J is the junction temperature ($^\circ\text{C}$)
- R_{TH} is the thermal resistance of the package ($^\circ\text{C/W}$)
- T_{JMAX} is maximum junction temperature ($^\circ\text{C}$)
- T_{AMAX} is maximum ambient temperature ($^\circ\text{C}$)

There will be additional power losses in the regulator circuit due to the inductor AC and Eco-mode losses, the catch diode and PCB trace resistance impacting the overall efficiency of the regulator.

8.2.1.2.11 Safe Operating Area

The safe operating area (SOA) of the device is shown in Figure 35, through Figure 38 for 3.3-V, 5-V, and 12-V outputs and varying amounts of forced air flow. The temperature derating curves represent the conditions at which the TPS54540-Q1 device is at or below the maximum operating temperature. The device is soldered directly to the EVM, which is a 4-layer double-sided PCB with 2-oz. copper. Careful attention must be paid to the other components chosen for the design, especially the catch diode.

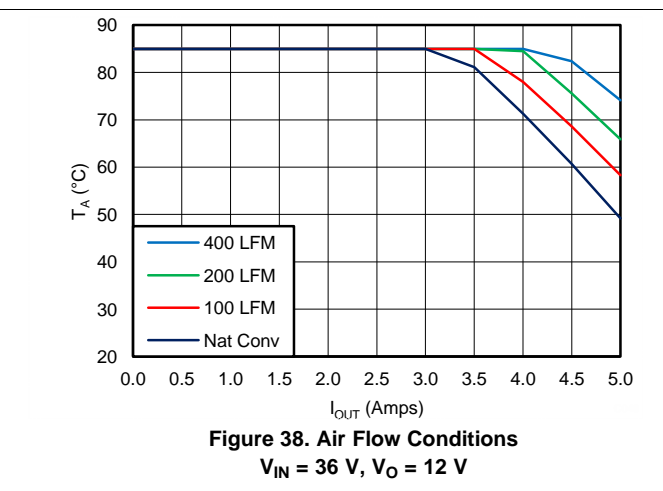
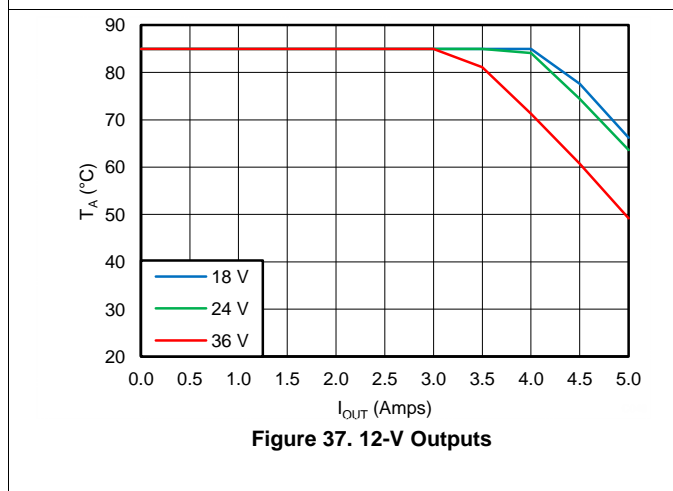
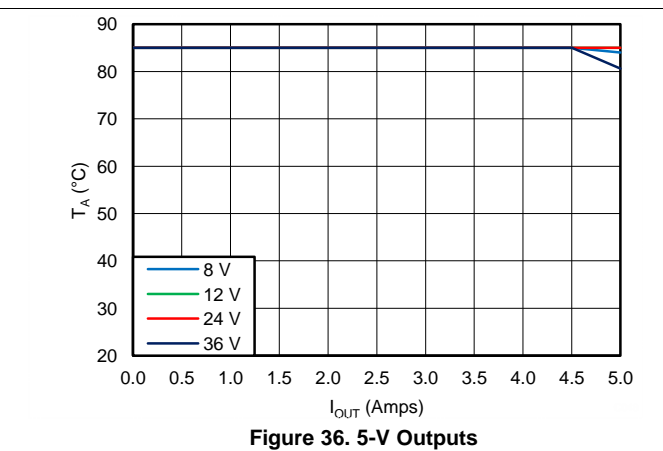
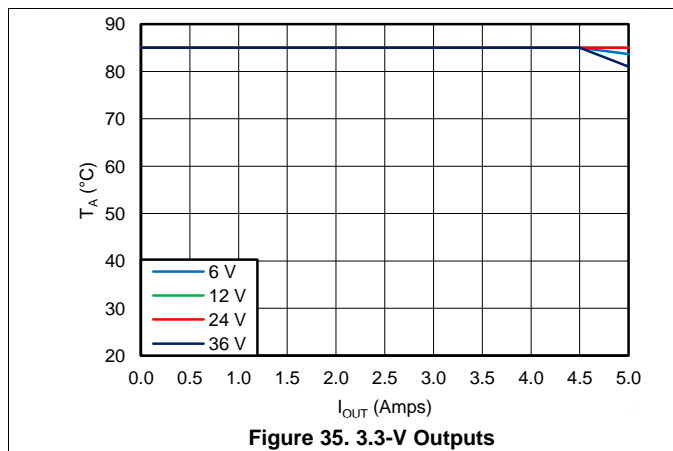

8.2.1.2.12 Discontinuous Conduction Mode and Eco-mode Boundary

With an input voltage of 12 V, the power supply enters discontinuous conduction mode when the output current is less than 560 mA. The power supply enters Eco-mode when the output current is lower than 18 mA. The input current draw is 240 μA with no load.

8.2.1.3 Application Curves

Measurements are taken with standard EVM using a 12-V input, 3.3-V output, and 5-A load unless otherwise noted.

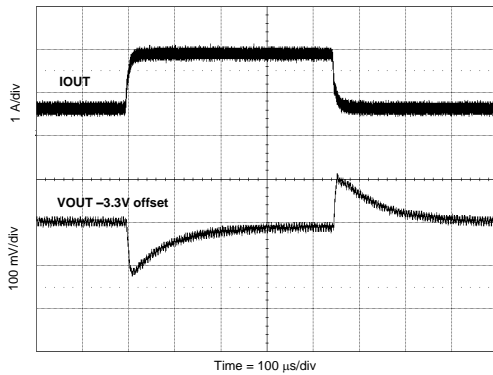

Figure 39. Load Transient

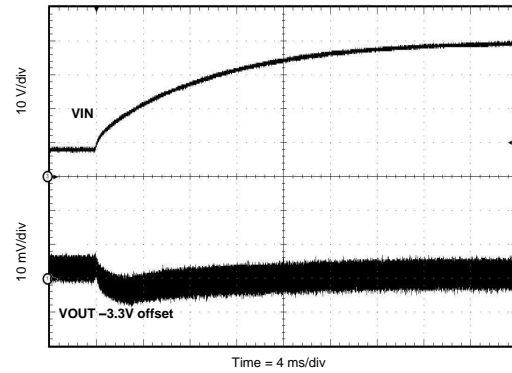

Figure 40. Line Transient (8 V to 40 V)

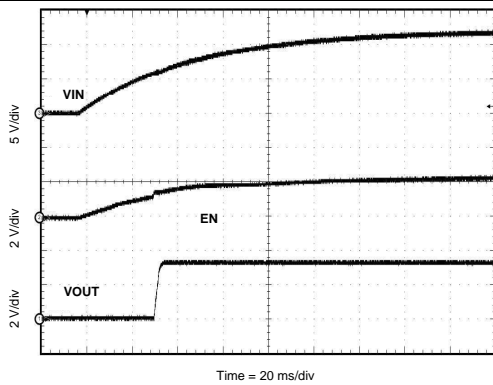

Figure 41. Start-Up With VIN

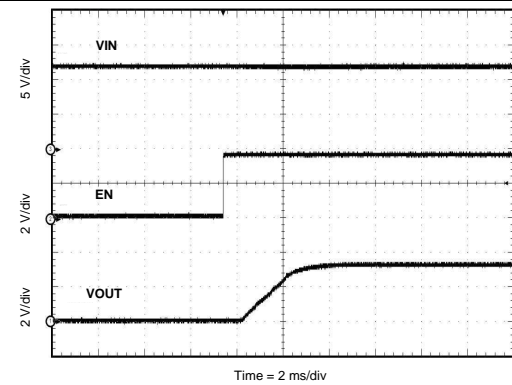

Figure 42. Start-Up With EN

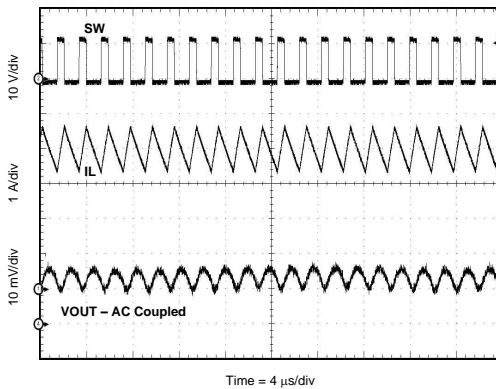

Figure 43. Output Ripple CCM

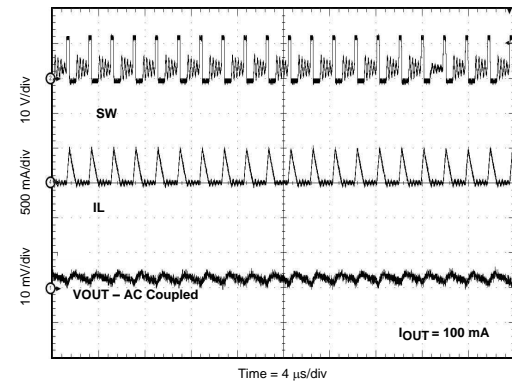

Figure 44. Output Ripple DCM

Measurements are taken with standard EVM using a 12-V input, 3.3-V output, and 5-A load unless otherwise noted.

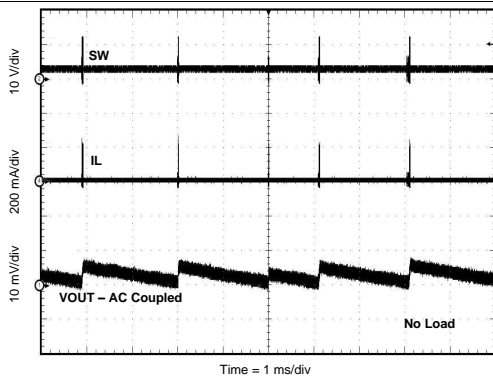

Figure 45. Output Ripple PSM

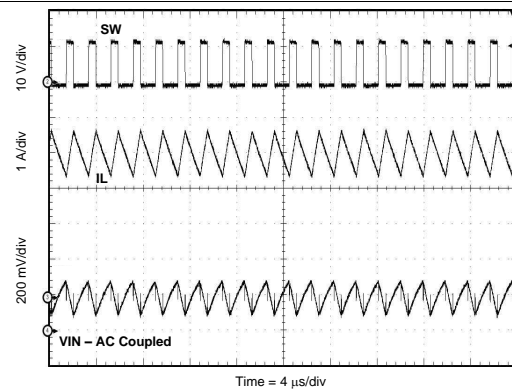

Figure 46. Input Ripple CCM

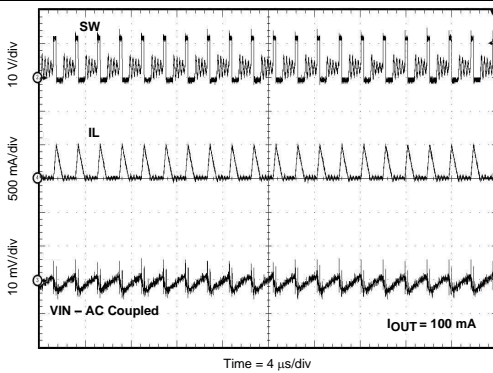

Figure 47. Input Ripple DCM

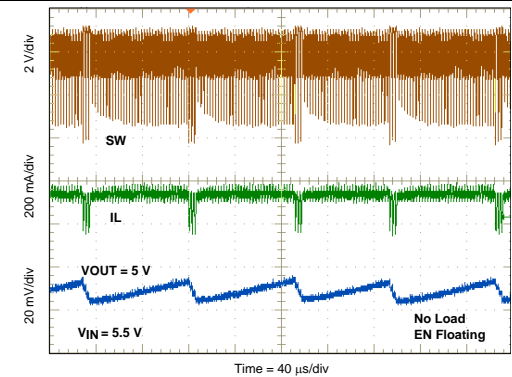

Figure 48. Low Dropout Operation

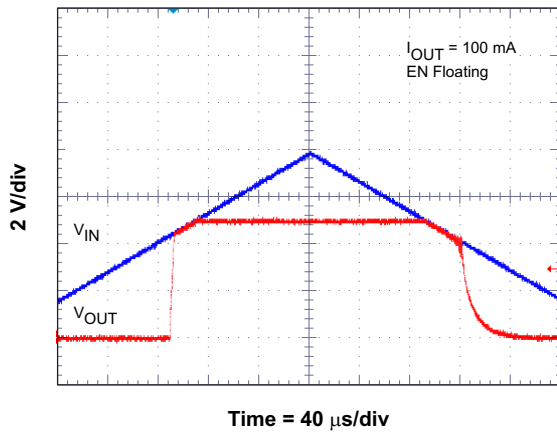

Figure 49. Low Dropout Operation

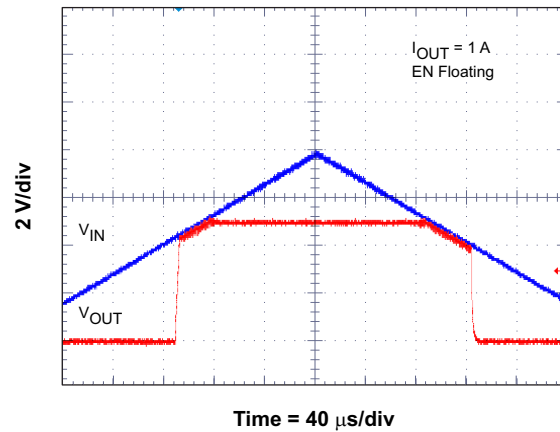

Figure 50. Low Dropout Operation

Measurements are taken with standard EVM using a 12-V input, 3.3-V output, and 5-A load unless otherwise noted.

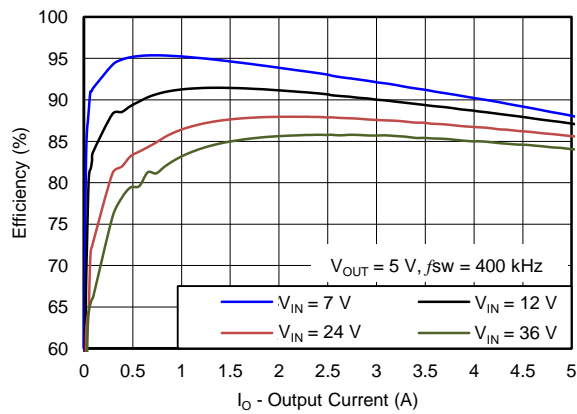

Figure 51. Efficiency vs Load Current

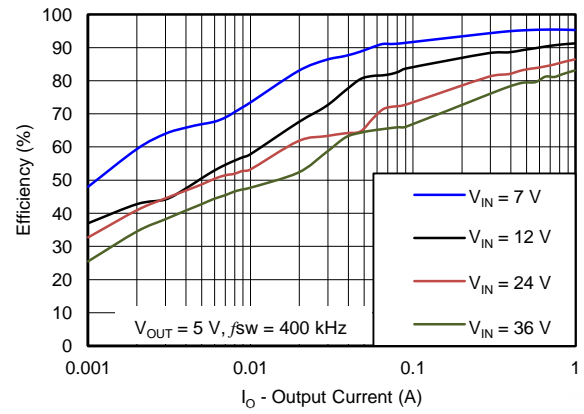

Figure 52. Light Load Efficiency

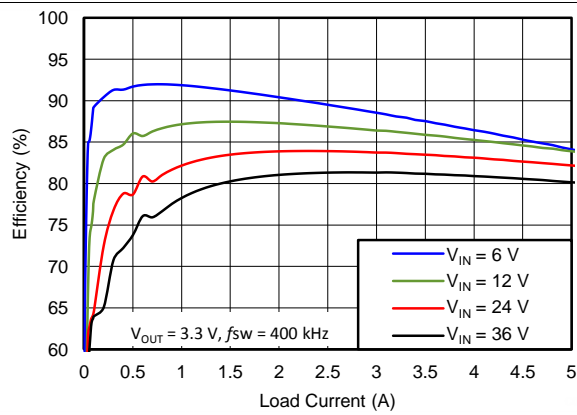

Figure 53. Efficiency vs Load Current

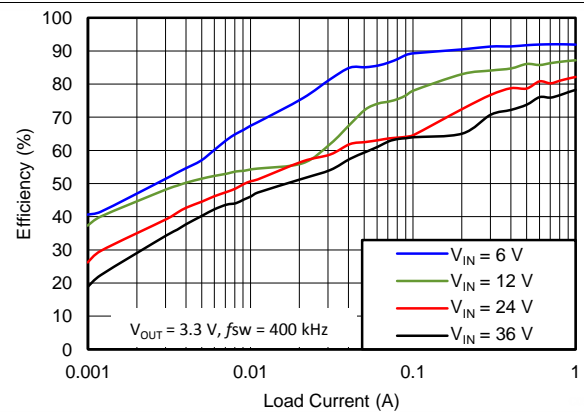

Figure 54. Light Load Efficiency

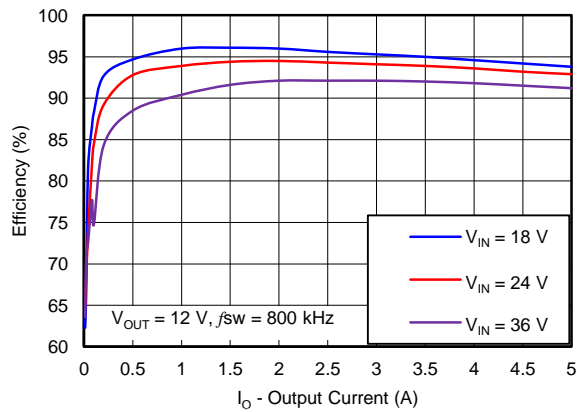

Figure 55. Efficiency vs Output Current

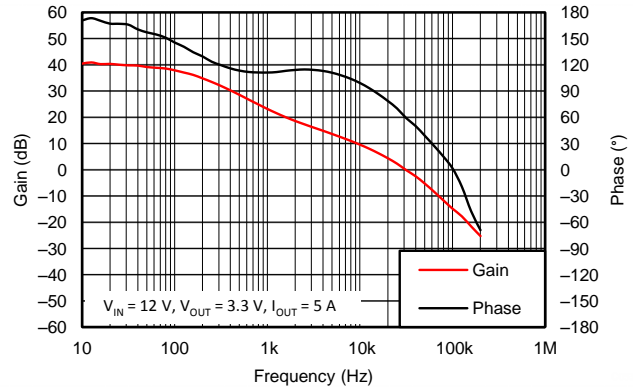

Figure 56. Overall Loop Frequency Response

Measurements are taken with standard EVM using a 12-V input, 3.3-V output, and 5-A load unless otherwise noted.

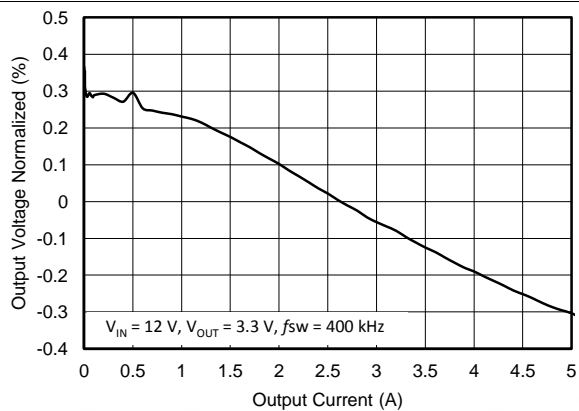

Figure 57. Regulation vs Load Current

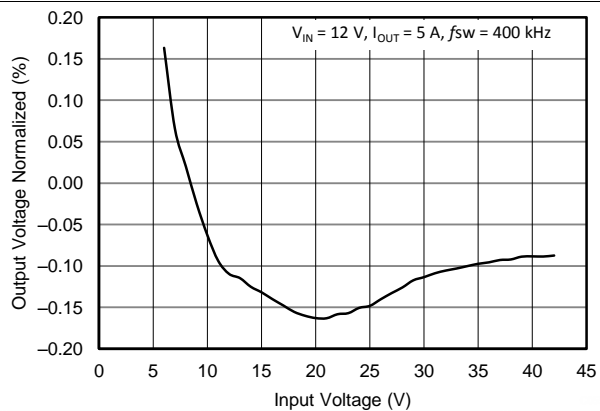

Figure 58. Regulation vs Input Voltage

8.2.2 Inverting Buck-Boost Topology for Positive Input to Negative Output

The TPS54540-Q1 device can be used to convert a positive input voltage to a split-rail positive and negative output voltage by using a coupled inductor. Example applications are amplifiers requiring a split-rail positive and negative voltage power supply. For a more detailed example, see [SLVA317](#).

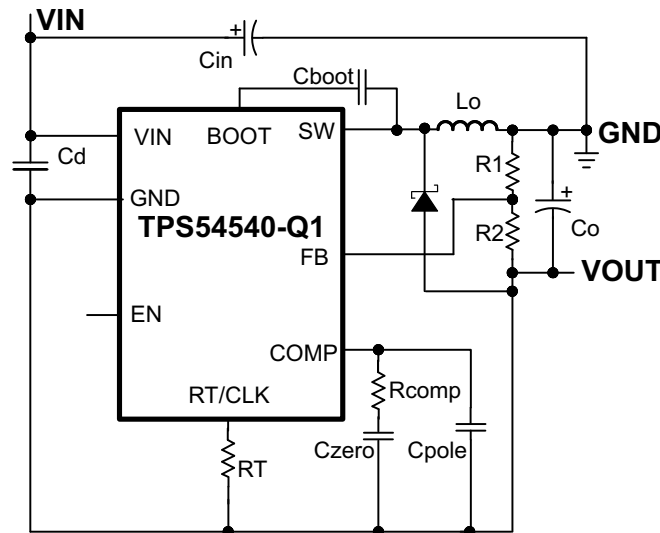

Figure 59. TPS54540-Q1 Inverting Power Supply from [SLVA317](#) Application Note

8.2.3 Split-Rail Power Supply

The TPS54540-Q1 device can be used to convert a positive input voltage to a split-rail positive and negative output voltage by using a coupled inductor. Example applications are amplifiers requiring a split-rail positive and negative voltage power supply. For a more detailed example, see [SLVA369](#).

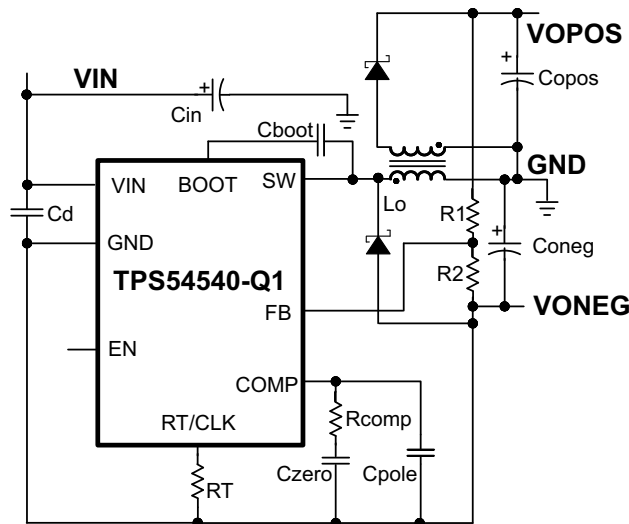

Figure 60. TPS54540-Q1 Split Rail Power Supply Based on the [SLVA369](#) Application Note

9 Power Supply Recommendations

The device is designed to operate from an input voltage supply range from 4.5 V to 42 V. This input supply must remain within this range. If the input supply is located more than a few inches from the TPS54540-Q1 converter, additional bulk capacitance may be required in addition to the ceramic bypass capacitors. An electrolytic capacitor with a value of 100 μ F is a typical choice.

10 Layout

10.1 Layout Guidelines

Layout is a critical portion of good power supply design. There are several signal paths that conduct fast changing currents or voltages that can interact with stray inductance or parasitic capacitance to generate noise or degrade performance. To reduce parasitic effects, the VIN pin should be bypassed to ground with a low-ESR ceramic bypass capacitor with X5R or X7R dielectric. Take care to minimize the loop area formed by the bypass capacitor connections, the VIN pin, and the anode of the catch diode. See Figure 61 for a PCB layout example. The GND pin should be tied directly to the power pad under the IC and the power pad.

The power pad must be connected to internal PCB ground planes using multiple vias directly under the IC. The SW pin should be routed to the cathode of the catch diode and to the output inductor. Because the SW connection is the switching node, the catch diode and output inductor must be located close to the SW pins, and the area of the PCB conductor minimized to prevent excessive capacitive coupling. For operation at full rated load, the top side ground area must provide adequate heat dissipating area. The RT/CLK pin is sensitive to noise so the RT resistor should be located as close as possible to the IC and routed with minimal lengths of trace. The additional external components can be placed approximately as shown. It may be possible to obtain acceptable performance with alternate PCB layouts; however, this layout has been shown to produce good results and is meant as a guideline.

10.2 Layout Example

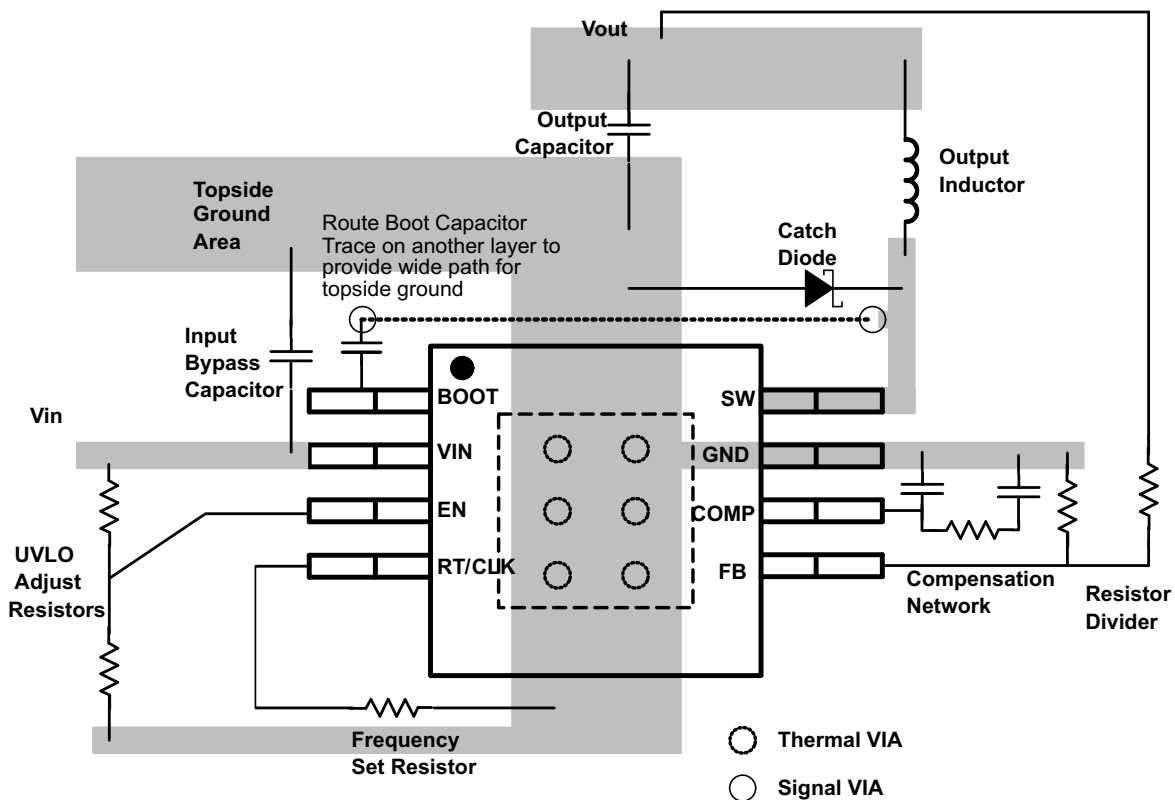

Figure 61. PCB Layout Example

10.3 Estimated Circuit Area

Boxing in the components in the design of Figure 34 the estimated printed-circuit-board area is 1.025 in² (661 mm²). This area does not include test points or connectors. If the area needs to be reduced, this can be done by using a two sided assembly and replacing the 0603 sized passives with a smaller sized equivalent.

11 Device and Documentation Support

11.1 Device Support

11.1.1 Third-Party Products Disclaimer

TI'S PUBLICATION OF INFORMATION REGARDING THIRD-PARTY PRODUCTS OR SERVICES DOES NOT CONSTITUTE AN ENDORSEMENT REGARDING THE SUITABILITY OF SUCH PRODUCTS OR SERVICES OR A WARRANTY, REPRESENTATION OR ENDORSEMENT OF SUCH PRODUCTS OR SERVICES, EITHER ALONE OR IN COMBINATION WITH ANY TI PRODUCT OR SERVICE.

11.1.2 Development Support

For the *TPS54360 and TPS54361 Family Design Excel Tool*, see the following:

- Design Calculator zip file ([SLVC452](#))

For more information about generating a complete design, see the following:

- [WEBENCH Design Center](#)

11.2 Documentation Support

11.2.1 Related Documentation

For related documentation see the following:

- *Creating GSM Power Supply from TPS54260* ([SLVA412](#))
- *Creating a Universal Car Charger for USB Devices From the TPS54240 and TPS2511* ([SLVA464](#))
- *Create an Inverting Power Supply from a Step-Down Regulator* ([SLVA317](#))
- *Create a Split-Rail Power Supply with a Wide Input Voltage Buck Regulator* ([SLVA369](#))

11.3 Community Resources

The following links connect to TI community resources. Linked contents are provided "AS IS" by the respective contributors. They do not constitute TI specifications and do not necessarily reflect TI's views; see TI's [Terms of Use](#).

TI E2E™ Online Community *TI's Engineer-to-Engineer (E2E) Community*. Created to foster collaboration among engineers. At e2e.ti.com, you can ask questions, share knowledge, explore ideas and help solve problems with fellow engineers.

Design Support *TI's Design Support* Quickly find helpful E2E forums along with design support tools and contact information for technical support.

11.4 Trademarks

Eco-mode, PowerPAD, E2E are trademarks of Texas Instruments.
All other trademarks are the property of their respective owners.

11.5 Electrostatic Discharge Caution



These devices have limited built-in ESD protection. The leads should be shorted together or the device placed in conductive foam during storage or handling to prevent electrostatic damage to the MOS gates.

11.6 Glossary

[SLYZ022](#) — *TI Glossary*.

This glossary lists and explains terms, acronyms, and definitions.

12 Mechanical, Packaging, and Orderable Information

The following pages include mechanical, packaging, and orderable information. This information is the most current data available for the designated devices. This data is subject to change without notice and revision of this document. For browser-based versions of this data sheet, refer to the left-hand navigation.

PACKAGING INFORMATION

Orderable Device	Status (1)	Package Type	Package Drawing	Pins	Package Qty	Eco Plan (2)	Lead finish/ Ball material (6)	MSL Peak Temp (3)	Op Temp (°C)	Device Marking (4/5)	Samples
TPS54540QDDAQ1	NRND	SO PowerPAD	DDA	8	75	RoHS & Green	NIPDAUAG	Level-2-260C-1 YEAR	-40 to 125	54540Q	
TPS54540QDDARQ1	NRND	SO PowerPAD	DDA	8	2500	RoHS & Green	NIPDAUAG	Level-2-260C-1 YEAR	-40 to 125	54540Q	

(1) The marketing status values are defined as follows:

ACTIVE: Product device recommended for new designs.

LIFEBUY: TI has announced that the device will be discontinued, and a lifetime-buy period is in effect.

NRND: Not recommended for new designs. Device is in production to support existing customers, but TI does not recommend using this part in a new design.

PREVIEW: Device has been announced but is not in production. Samples may or may not be available.

OBSOLETE: TI has discontinued the production of the device.

(2) **RoHS:** TI defines "RoHS" to mean semiconductor products that are compliant with the current EU RoHS requirements for all 10 RoHS substances, including the requirement that RoHS substance do not exceed 0.1% by weight in homogeneous materials. Where designed to be soldered at high temperatures, "RoHS" products are suitable for use in specified lead-free processes. TI may reference these types of products as "Pb-Free".

RoHS Exempt: TI defines "RoHS Exempt" to mean products that contain lead but are compliant with EU RoHS pursuant to a specific EU RoHS exemption.

Green: TI defines "Green" to mean the content of Chlorine (Cl) and Bromine (Br) based flame retardants meet JS709B low halogen requirements of <=1000ppm threshold. Antimony trioxide based flame retardants must also meet the <=1000ppm threshold requirement.

(3) MSL, Peak Temp. - The Moisture Sensitivity Level rating according to the JEDEC industry standard classifications, and peak solder temperature.

(4) There may be additional marking, which relates to the logo, the lot trace code information, or the environmental category on the device.

(5) Multiple Device Markings will be inside parentheses. Only one Device Marking contained in parentheses and separated by a "~" will appear on a device. If a line is indented then it is a continuation of the previous line and the two combined represent the entire Device Marking for that device.

(6) Lead finish/Ball material - Orderable Devices may have multiple material finish options. Finish options are separated by a vertical ruled line. Lead finish/Ball material values may wrap to two lines if the finish value exceeds the maximum column width.

Important Information and Disclaimer:The information provided on this page represents TI's knowledge and belief as of the date that it is provided. TI bases its knowledge and belief on information provided by third parties, and makes no representation or warranty as to the accuracy of such information. Efforts are underway to better integrate information from third parties. TI has taken and continues to take reasonable steps to provide representative and accurate information but may not have conducted destructive testing or chemical analysis on incoming materials and chemicals. TI and TI suppliers consider certain information to be proprietary, and thus CAS numbers and other limited information may not be available for release.

In no event shall TI's liability arising out of such information exceed the total purchase price of the TI part(s) at issue in this document sold by TI to Customer on an annual basis.

OTHER QUALIFIED VERSIONS OF TPS54540-Q1 :

- Catalog: [TPS54540](#)

NOTE: Qualified Version Definitions:

- Catalog - TI's standard catalog product

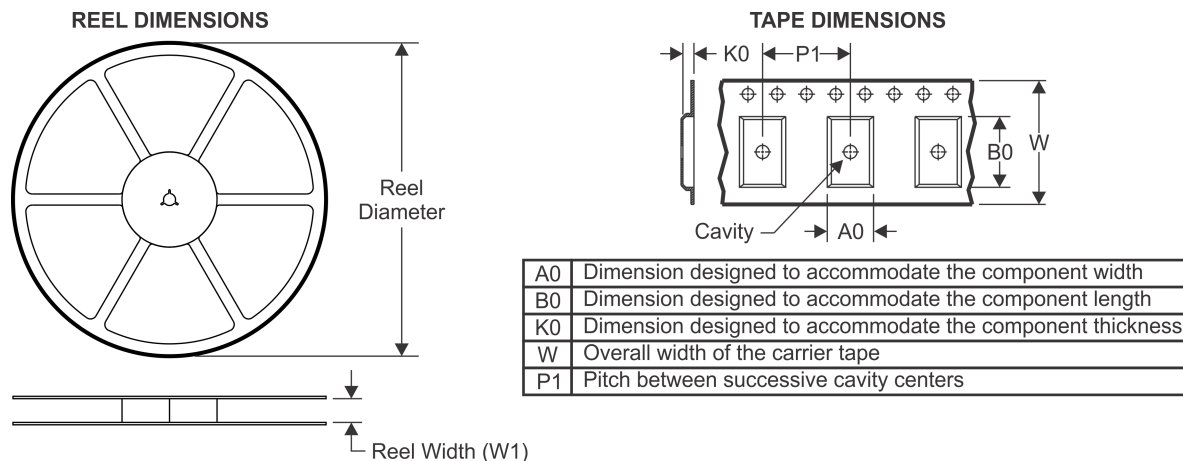
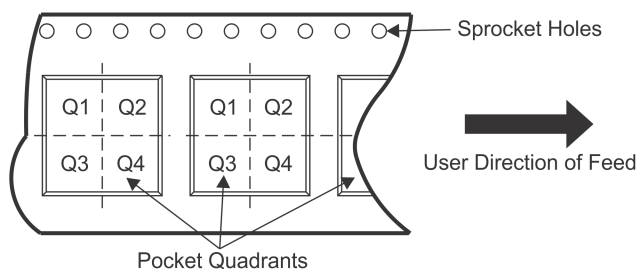
TAPE AND REEL INFORMATION

QUADRANT ASSIGNMENTS FOR PIN 1 ORIENTATION IN TAPE

*All dimensions are nominal

Device	Package Type	Package Drawing	Pins	SPQ	Reel Diameter (mm)	Reel Width W1 (mm)	A0 (mm)	B0 (mm)	K0 (mm)	P1 (mm)	W (mm)	Pin1 Quadrant
TPS54540QDDARQ1	SO Power PAD	DDA	8	2500	330.0	12.8	6.4	5.2	2.1	8.0	12.0	Q1

TAPE AND REEL BOX DIMENSIONS

*All dimensions are nominal

Device	Package Type	Package Drawing	Pins	SPQ	Length (mm)	Width (mm)	Height (mm)
TPS54540QDDARQ1	SO PowerPAD	DDA	8	2500	366.0	364.0	50.0

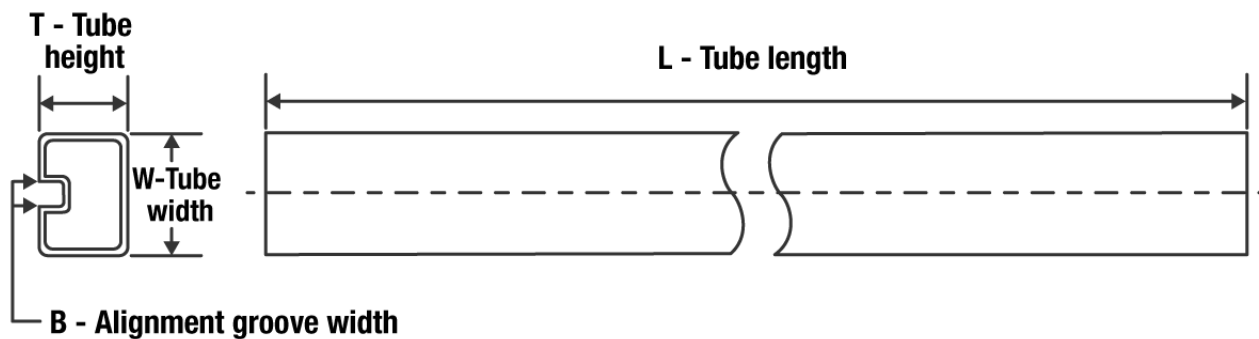
TUBE

*All dimensions are nominal

Device	Package Name	Package Type	Pins	SPQ	L (mm)	W (mm)	T (μm)	B (mm)
TPS54540QDDAQ1	DDA	HSOIC	8	75	517	7.87	635	4.25

IMPORTANT NOTICE AND DISCLAIMER

TI PROVIDES TECHNICAL AND RELIABILITY DATA (INCLUDING DATA SHEETS), DESIGN RESOURCES (INCLUDING REFERENCE DESIGNS), APPLICATION OR OTHER DESIGN ADVICE, WEB TOOLS, SAFETY INFORMATION, AND OTHER RESOURCES "AS IS" AND WITH ALL FAULTS, AND DISCLAIMS ALL WARRANTIES, EXPRESS AND IMPLIED, INCLUDING WITHOUT LIMITATION ANY IMPLIED WARRANTIES OF MERCHANTABILITY, FITNESS FOR A PARTICULAR PURPOSE OR NON-INFRINGEMENT OF THIRD PARTY INTELLECTUAL PROPERTY RIGHTS.

These resources are intended for skilled developers designing with TI products. You are solely responsible for (1) selecting the appropriate TI products for your application, (2) designing, validating and testing your application, and (3) ensuring your application meets applicable standards, and any other safety, security, regulatory or other requirements.

These resources are subject to change without notice. TI grants you permission to use these resources only for development of an application that uses the TI products described in the resource. Other reproduction and display of these resources is prohibited. No license is granted to any other TI intellectual property right or to any third party intellectual property right. TI disclaims responsibility for, and you will fully indemnify TI and its representatives against, any claims, damages, costs, losses, and liabilities arising out of your use of these resources.

TI's products are provided subject to [TI's Terms of Sale](#) or other applicable terms available either on ti.com or provided in conjunction with such TI products. TI's provision of these resources does not expand or otherwise alter TI's applicable warranties or warranty disclaimers for TI products.

TI objects to and rejects any additional or different terms you may have proposed.

Mailing Address: Texas Instruments, Post Office Box 655303, Dallas, Texas 75265
Copyright © 2022, Texas Instruments Incorporated

Looking for pricing, stock, or lifecycle information?

Click below to explore more details on WIN SOURCE:

 [View TPS54540QDDARQ1 on WIN SOURCE](#)

 [Texas Instruments](#) Information

Optimize Your Supply Chain with WIN SOURCE Solutions

-  Global Sourcing Solution
-  Obsolete Management
-  Cost Control Management
-  Shortage Management
-  Alternative Solution
-  Excess Inventory Management