

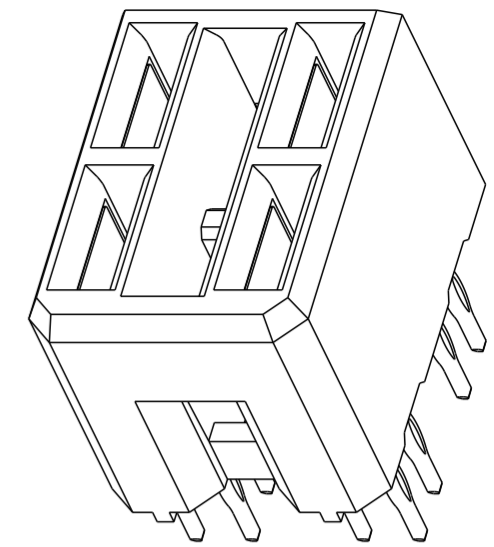

**THE DATASHEET OF
10028916-5555P00LF**

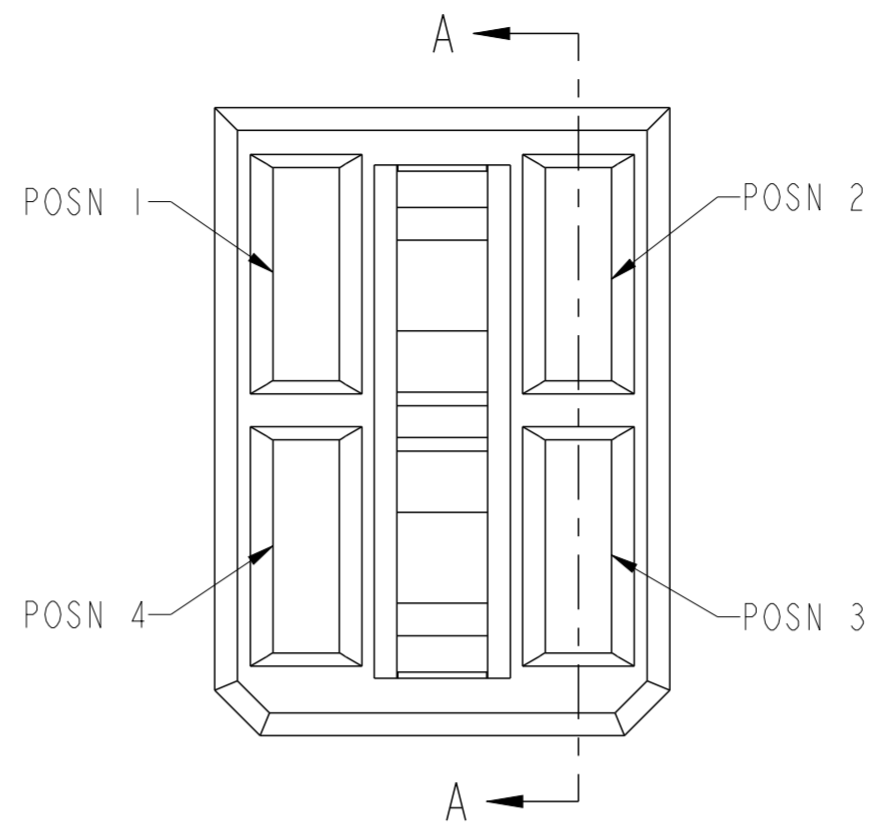

PRODUCT NUMBER ("LF" DENOTES LEAD-FREE)	CONTACT PLATING NOTE	MATING LENGTH, DIM "X"				ROHS COMPATIBILITY
		POSN 1	POSN 2	POSN 3	POSN 4	
10028916-4444P00	2					N/A
10028916-4444P00LF	3	1.10	1.10	1.10	1.10	SEE NOTE 9
10028916-5555P00	2					N/A
10028916-5555P00LF	3	2.60	2.60	2.60	2.60	SEE NOTE 9
10028916-4555P00	2					N/A
10028916-4555P00LF	3	1.10	2.60	2.60	2.60	SEE NOTE 9
10028916-5455P00	2					N/A
10028916-5455P00LF	3	2.60	1.10	2.60	2.60	SEE NOTE 9
10028916-5545P00	2					N/A
10028916-5545P00LF	3	2.60	2.60	1.10	2.60	SEE NOTE 9
10028916-5554P00	2					N/A
10028916-5554P00LF	3	2.60	2.60	2.60	1.10	SEE NOTE 9
10028916-4554P00	2					N/A
10028916-4554P00LF	3	1.10	2.60	2.60	1.10	SEE NOTE 9
10028916-4455P00	2					N/A
10028916-4455P00LF	3	1.10	1.10	2.60	2.60	SEE NOTE 9
10028916-5544P00	2					N/A
10028916-5544P00LF	3	2.60	2.60	1.10	1.10	SEE NOTE 9



SCALE 4:1

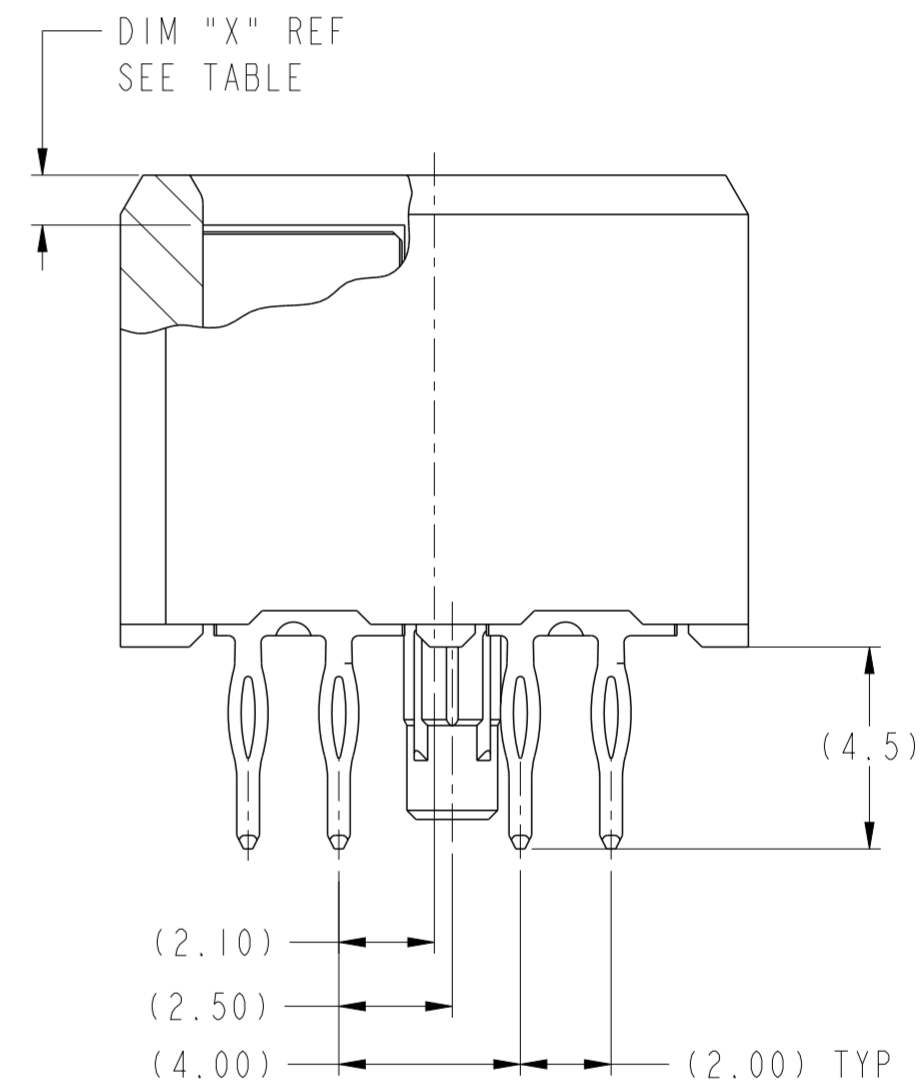
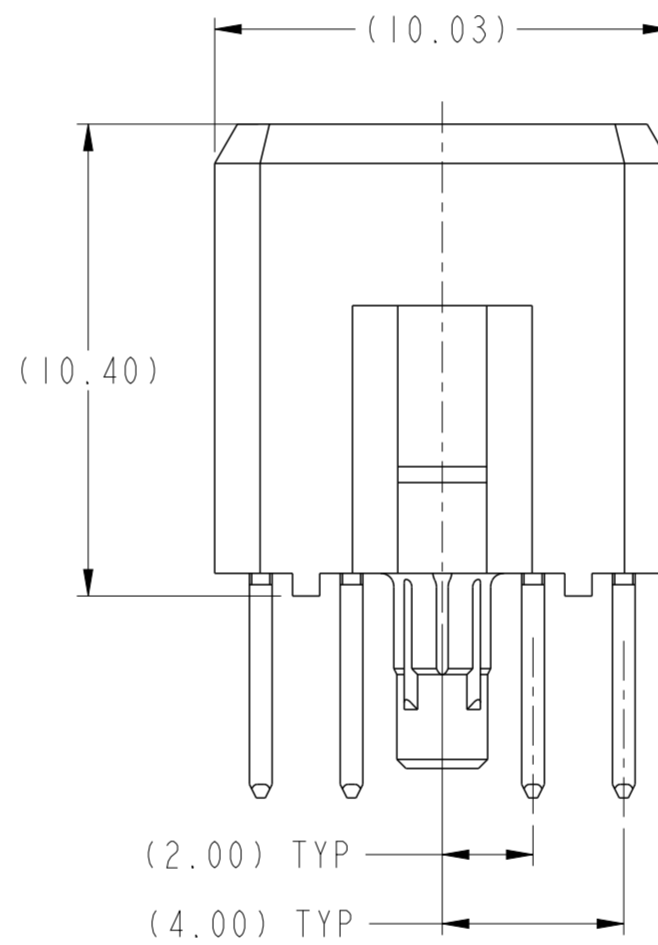
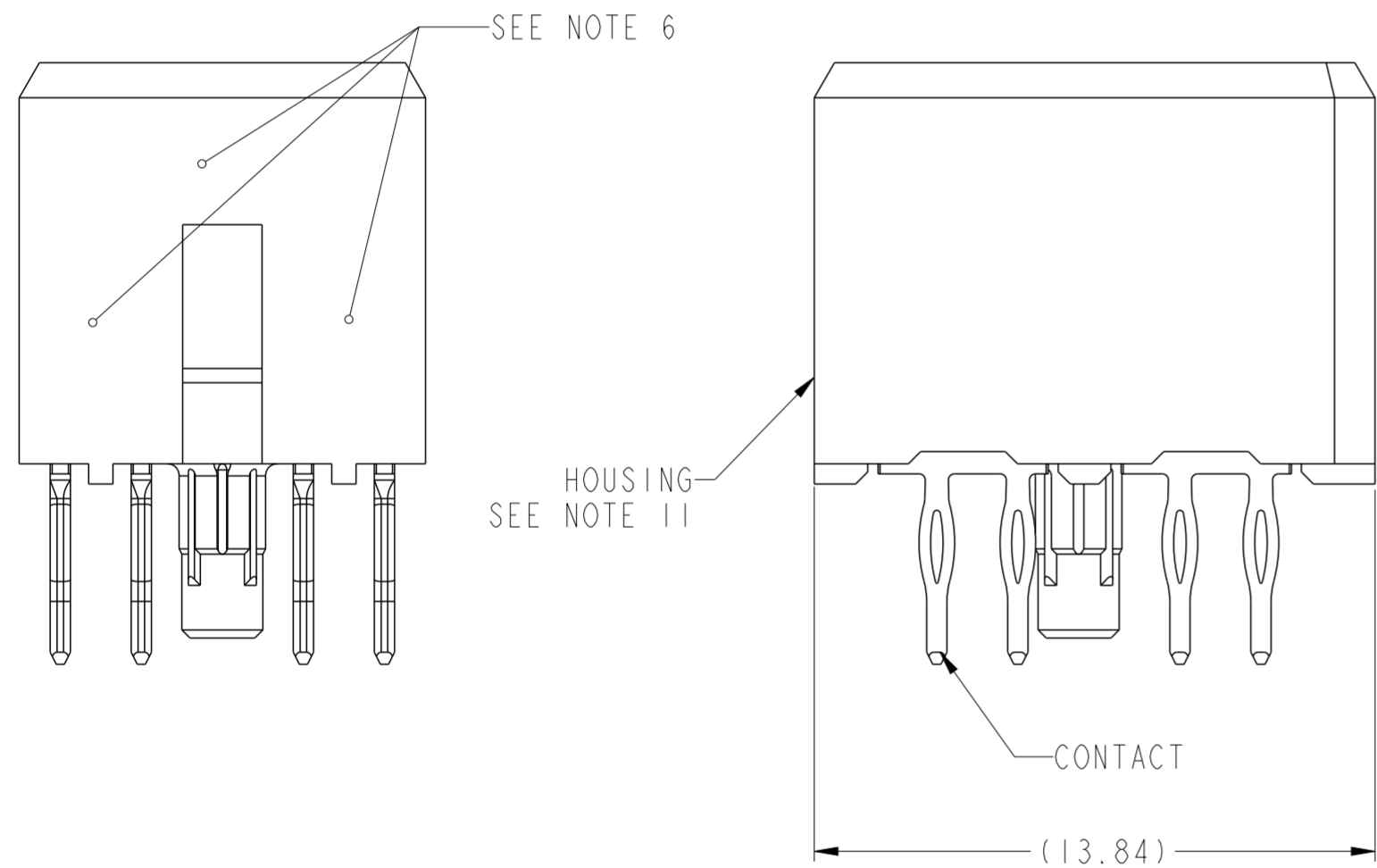

SECTION A-A

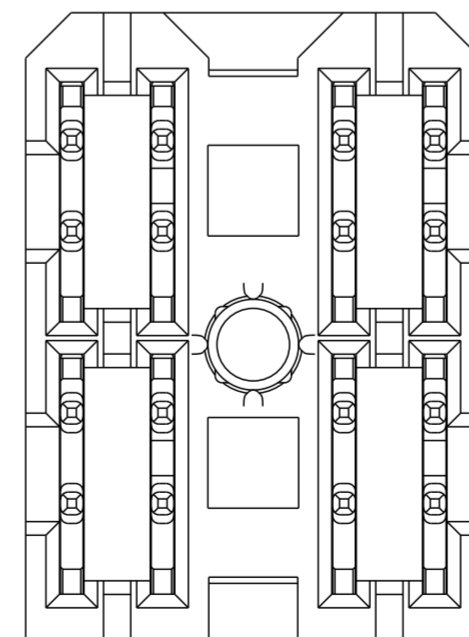

spec ref	GS-12-220	dr	Chen-Hong Yan	2005/08/04	projection	MM	size	A2	scale	6:1				
tolerance std	ASME Y14.5	eng	Terry Luo	2019/04/23			ecn no	ELX-DG-33324-1	rel level	Released				
TOLERANCES UNLESS OTHERWISE SPECIFIED		chr	-	app							Heaven Cen	2019/04/25	product family	2mm High Power
surface	3.2	linear	0.X	±.3									title	2X2 VERTICAL RECEPTACLE ASSY
		angular	0°	±2°			dwg no	10028916	rev	M				

PDS: Rev :M

STATUS:Released

Printed: Apr 25, 2019

TOP LAYER DESCRIPTION	TABLE I PLATED THROUGH-HOLE REQUIREMENTS							
	DRILLED HOLE DIAMETER	COPPER THICKNESS	TIN-LEAD THICKNESS	NICKEL THICKNESS	GOLD THICKNESS	TIN THICKNESS	SILVER THICKNESS	FINISHED HOLE DIAMETER (DIM "A")
TIN-LEAD	0.81-0.86 (0.85 DRILL)	0.025 - 0.050	0.005 - 0.015	--	--	--	--	0.65 - 0.80
IMMERSION TIN	0.81-0.86 (0.85 DRILL)	0.025 - 0.050	--	--	--	0.9 - 1.5um	--	0.70 - 0.80
IMMERSION SILVER	0.81-0.86 (0.85 DRILL)	0.025 - 0.050	--	--	--	--	0.15 - 0.65um	0.70 - 0.80
COPPER (SEE NOTE 12)	0.81-0.86 (0.85 DRILL)	0.025 - 0.050	--	--	--	--	--	0.70 - 0.80
GOLD	0.81-0.86 (0.85 DRILL)	0.025 - 0.050	--	0.003 - 0.007	FLASH UP TO 0.0002	--	--	0.69 - 0.80

NOTES:

- CONNECTOR MATERIALS:
HOUSING: HIGH TEMPERATURE THERMOPLASTIC, BLACK
UL 94V-0 COMPLIANT
CONTACT: HIGH PERFORMANCE COPPER ALLOY
- CONTACT PLATING:
PRESS-FIT TAIL: 0.5um TIN-LEAD OVER NICKEL.
SEPARABLE INTERFACE: 0.76um MIN GXT OVER NICKEL.
- CONTACT PLATING (LEAD-FREE):
PRESS-FIT TAIL: 0.5um MIN MATTE TIN OVER NICKEL.
SEPARABLE INTERFACE: 0.76um MIN GXT OVER NICKEL.
- PRODUCT SPECIFICATION: GS-12-220
- APPLICATION SPECIFICATION: GS-20-023
- PRODUCT MARKING (PRODUCT NUMBER & LOT CODE) ON HOUSING IN AREA SHOWN, EITHER SIDE.
- MINIMUM NOMINAL BOARD THICKNESS: 2.4mm
- REFER TO CUSTOMER DRAWING SK10035911 FOR INFORMATION REGARDING PCB LAYOUT OF POWER AND GUIDE MODULES RELATIVE TO AIRMAX SIGNAL MODULES.
- PRODUCT MEETS EUROPEAN UNION DIRECTIVES AND OTHER COUNTRY REGULATIONS AS DESCRIBED IN FCI SPECIFICATION GS-22-008.
- PACKAGING MEETS FCI SPECIFICATION GS-14-920
- HOUSING COMPONENT WILL WITHSTAND EXPOSURE TO 260° PEAK TEMPERATURE FOR 60 SECONDS IN A CONVECTION, INFRA-RED OR VAPOR-PHASE REFLOW OVEN.
- COPPER PLATING THICKNESS AT CENTER OF VIA HOLE CAN BE NO MORE THAN 0.003 LESS THAN OTHER AREAS.
- KEEPOUT AREA APPLICABLE FOR HIGH PROFILE POWER HEADER WITH 14.70MM HEIGHT ABOVE TOP SURFACE OF DAUGHTER CARD. IT MAY BE 11.5MM IF A LOWER PROFILE HEADER IS USED.

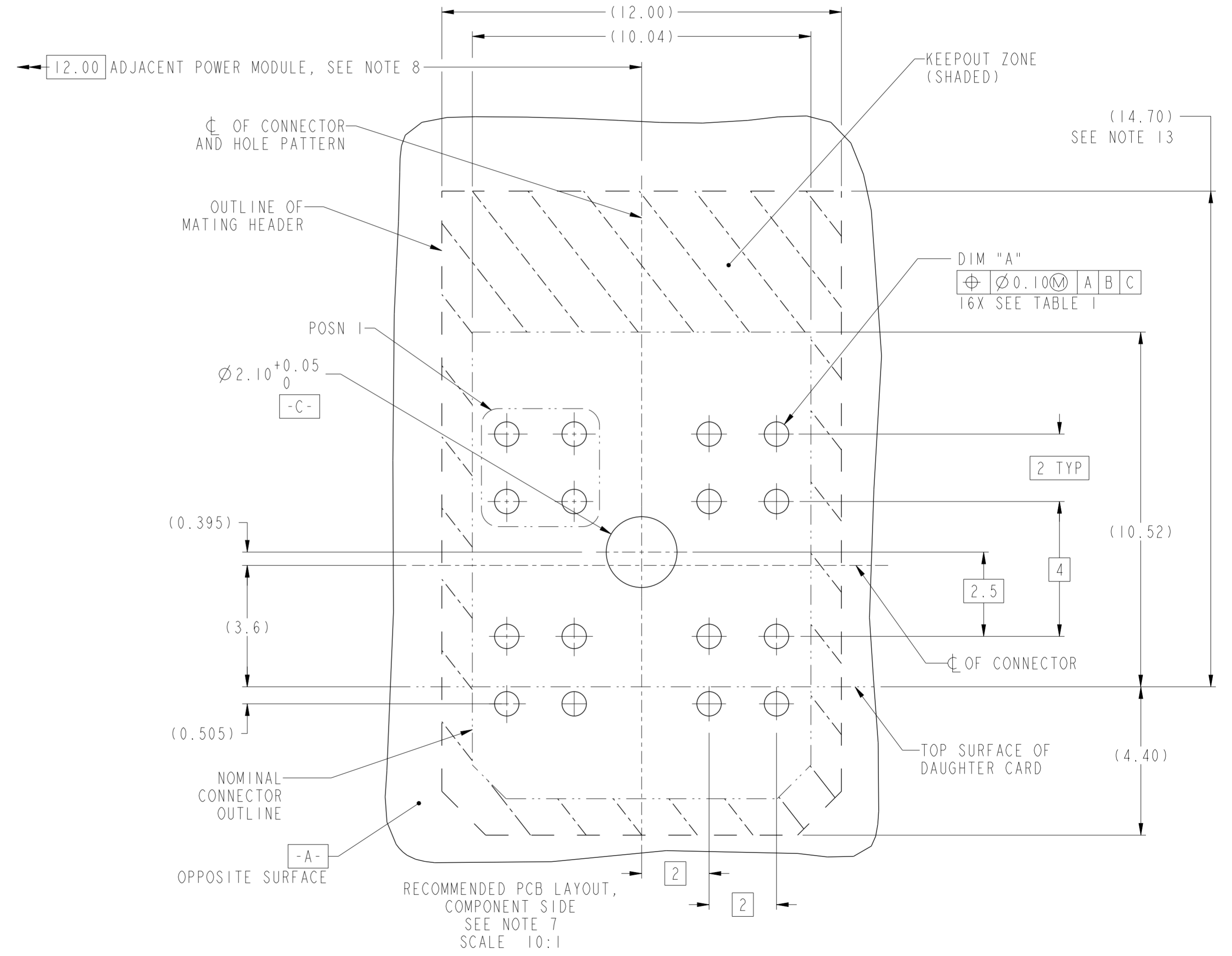

Amphenol FCI

© 2016 AFCI

spec ref	GS-12-220	dr	Chen-Hong Yan	2005/08/04	projection	MM	size	A2	scale	1:1	
tolerance std	ASME Y14.5	eng	Terry Luo	2019/04/23	chr	-	ecn no	ELX-DG-33324-1	rel level	Released	
surface	3.2	appr	Heaven Cen	2019/04/25	product family	2mm High Power	rel level	Released	cat. no.	Product - Customer Drw	
ASME Y14.5	linear	0.X	±.3	0.XX	±.1	0.XXX	±.05	angular	0°	±2°	
		Amphenol FCI		TITLE		2X2 VERTICAL RECEPTACLE ASSY		10028916		rev	M

Looking for pricing, stock, or lifecycle information?

Click below to explore more details on WIN SOURCE:

 [View 10028916-5555P00LF on WIN SOURCE](#)

 [Amphenol FCI Information](#)

Optimize Your Supply Chain with WIN SOURCE Solutions

-  Global Sourcing Solution
-  Obsolete Management
-  Cost Control Management
-  Shortage Management
-  Alternative Solution
-  Excess Inventory Management