



**THE DATASHEET OF
LTC3630AEMSE#PBF**



High Efficiency, 76V 500mA Synchronous Step-Down Converter

FEATURES

- **Wide Operating Input Voltage Range: 4V to 76V**
- **Synchronous Operation for Highest Efficiency**
- **Internal High Side and Low Side Power MOSFETs**
- **No Compensation Required**
- **Adjustable 50mA to 500mA Maximum Output Current**
- Low Dropout Operation: 100% Duty Cycle
- Low Quiescent Current: 12 μ A
- Wide Output Range: 0.8V to V_{IN}
- 0.8V \pm 1% Feedback Voltage Reference
- Precise RUN Pin Threshold
- Internal and External Soft-Start
- Programmable 1.8V, 3.3V, 5V or Adjustable Output
- Few External Components Required
- Low Profile (0.75mm) 3mm \times 5mm DFN and Thermally-Enhanced MSE16 Packages

APPLICATIONS

- Industrial Control Supplies
- Medical Devices
- Portable Instruments
- Automotive
- Avionics

Δ , LT, LTC, LTM, Burst Mode, Linear Technology and the Linear logo are registered trademarks and ThinSOT is a trademark of Linear Technology Corporation. All other trademarks are the property of their respective owners.

DESCRIPTION

The **LTC[®]3630A** is a high efficiency step-down DC/DC converter with internal high side and synchronous power switches that draws only 12 μ A typical DC supply current while maintaining a regulated output voltage at no load.

The LTC3630A can supply up to 500mA load current and features a programmable peak current limit that provides a simple method for optimizing efficiency and for reducing output ripple and component size. The LTC3630A's combination of Burst Mode[®] operation, integrated power switches, low quiescent current, and programmable peak current limit provides high efficiency over a broad range of load currents.

With its wide input range of 4V to 76V, the LTC3630A is a robust converter suited for regulating a wide variety of power sources. A feedback comparator output enables multiple LTC3630As to be paralleled in higher current applications.

The LTC3630A is available in the thermally-enhanced 3mm \times 5mm DFN and the MSE16 packages.

PARAMETER	LTC3630A	LTC3630
Maximum Operating V_{IN}	76V	65V
Absolute Maximum V_{IN}	80V	70V

TYPICAL APPLICATION

12.5V to 76V Input to 12V Output, 500mA Step-Down Converter

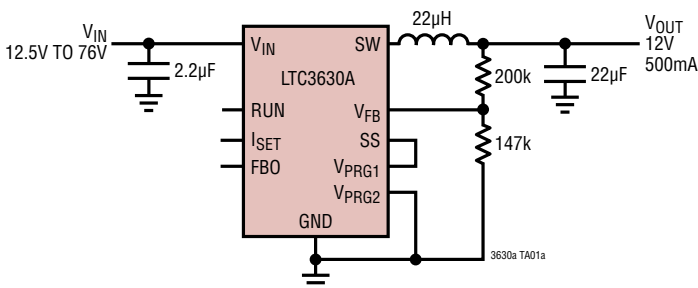

Efficiency and Power Loss vs Load Current

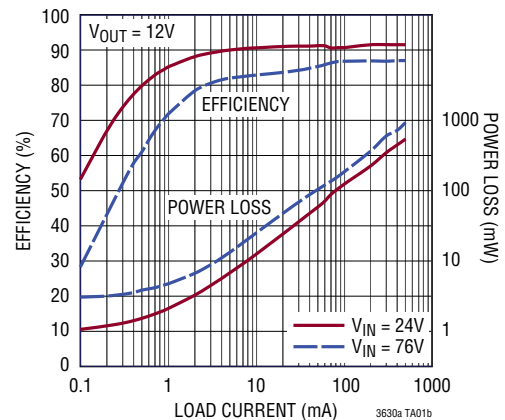

3630afc

LTC3630A

ABSOLUTE MAXIMUM RATINGS (Note 1)

V_{IN} Supply Voltage.....	-0.3V to 80V	Operating Junction Temperature Range (Notes 2, 3, 4)
RUN Voltage.....	-0.3V to 6V	LTC3630AE, LTC3630AI
SS, FBO, I_{SET} Voltages.....	-0.3V to 6V	LTC3630AH
V_{FB} , V_{PRG1} , V_{PRG2} Voltages	-0.3V to 6V	LTC3630AMP.....
		Storage Temperature Range
		Lead Temperature (Soldering, 10 sec)
		MSOP
		300°C

PIN CONFIGURATION

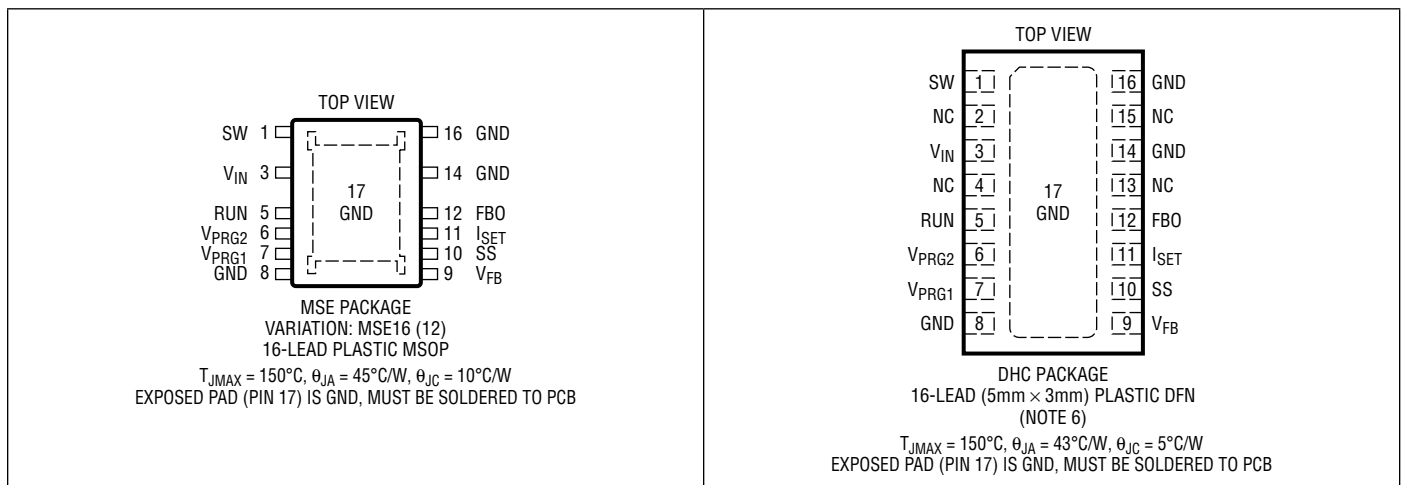

ORDER INFORMATION

LEAD FREE FINISH	TAPE AND REEL	PART MARKING*	PACKAGE DESCRIPTION	TEMPERATURE RANGE
LTC3630AEMSE#PBF	LTC3630AEMSE#TRPBF	3630A	16-Lead Plastic MSOP	-40°C to 125°C
LTC3630AIMSE#PBF	LTC3630AIMSE#TRPBF	3630A	16-Lead Plastic MSOP	-40°C to 125°C
LTC3630AHMSE#PBF	LTC3630AHMSE#TRPBF	3630A	16-Lead Plastic MSOP	-40°C to 150°C
LTC3630AMPSE#PBF	LTC3630AMPSE#TRPBF	3630A	16-Lead Plastic MSOP	-55°C to 150°C
LTC3630AEDHC#PBF	LTC3630AEDHC#TRPBF	3630A	16-Lead (5mm x 3mm) Plastic DFN	-40°C to 125°C
LTC3630AIDHC#PBF	LTC3630AIDHC#TRPBF	3630A	16-Lead (5mm x 3mm) Plastic DFN	-40°C to 125°C
LTC3630AHDHC#PBF	LTC3630AHDHC#TRPBF	3630A	16-Lead (5mm x 3mm) Plastic DFN	-40°C to 150°C
LTC3630AMPDHC#PBF	LTC3630AMPDHC#TRPBF	3630A	16-Lead (5mm x 3mm) Plastic DFN	-55°C to 150°C

Consult LTC Marketing for parts specified with wider operating temperature ranges. *The temperature grade is identified by a label on the shipping container. Consult LTC Marketing for information on nonstandard lead based finish parts.

For more information on lead free part marking, go to: <http://www.linear.com/leadfree/>

For more information on tape and reel specifications, go to: <http://www.linear.com/tapeandreeel/>

ELECTRICAL CHARACTERISTICS

The ● denotes the specifications which apply over the specified operating junction temperature range, otherwise specifications are at $T_A = 25^\circ\text{C}$ (Note 2). $V_{IN} = 12\text{V}$, unless otherwise noted.

SYMBOL	PARAMETER	CONDITIONS	MIN	TYP	MAX	UNITS
Input Supply (V_{IN})						
V_{IN}	Input Voltage Operating Range		4		76	V
V_{OUT}	Output Voltage Operating Range	(Note 7)	0.8		V_{IN}	V
UVLO	V_{IN} Undervoltage Lockout	V_{IN} Rising	● 3.45	3.65	3.85	V
		V_{IN} Falling Hysteresis	● 3.30	3.5 150	3.70	V mV
I_Q	DC Supply Current (Note 5) Active Mode Sleep Mode Shutdown Mode	No Load $V_{RUN} = 0\text{V}$		165	350	μA
				12	20	μA
				5	10	μA
V_{RUN}	RUN Pin Threshold Voltage	RUN Rising	1.17	1.21	1.25	V
		RUN Falling Hysteresis	1.06	1.10 110	1.14	V mV
Output Supply (V_{FB})						
$V_{FB(ADJ)}$	Feedback Comparator Threshold Voltage (Adjustable Output)	V_{FB} Rising, $V_{PRG1} = V_{PRG2} = 0\text{V}$ LTC3630AE, LTC3630AI LTC3630AH, LTC3630AMP	● 0.792	0.800	0.808	V
			● 0.788	0.800	0.812	V
V_{FBH}	Feedback Comparator Hysteresis (Adjustable Output)	V_{FB} Falling, $V_{PRG1} = V_{PRG2} = 0\text{V}$	● 2.5	5	7	mV
I_{FB}	Feedback Pin Current	$V_{FB} = 1\text{V}$, $V_{PRG1} = 0\text{V}$, $V_{PRG2} = 0\text{V}$	-10	0	10	nA
$V_{FB(FIXED)}$	Feedback Comparator Threshold Voltages (Fixed Output)	V_{FB} Rising, $V_{PRG1} = \text{SS}$, $V_{PRG2} = 0\text{V}$ V_{FB} Falling, $V_{PRG1} = \text{SS}$, $V_{PRG2} = 0\text{V}$	● 4.940	5.015	5.090	V
			● 4.910	4.985	5.060	V
		V_{FB} Rising, $V_{PRG1} = 0\text{V}$, $V_{PRG2} = \text{SS}$ V_{FB} Falling, $V_{PRG1} = 0\text{V}$, $V_{PRG2} = \text{SS}$	● 3.260	3.310	3.360	V
			● 3.240	3.290	3.340	V
$\Delta V_{LINEREG}$	Feedback Voltage Line Regulation	$V_{IN} = 4\text{V}$ to 76V	● 1.780	1.810	1.840	V
			● 1.770	1.8	1.83	V
				0.001		%/V
Operation						
I_{PEAK}	Peak Current Comparator Threshold	I_{SET} Floating	● 1	1.2	1.4	A
		100k Resistor from I_{SET} to GND	● 0.45	0.6	0.75	A
		I_{SET} Shorted to GND	● 0.09	0.12	0.15	A
R_{ON}	Power Switch On-Resistance Top Switch Bottom Switch	$I_{SW} = -200\text{mA}$		1.00		Ω
		$I_{SW} = 200\text{mA}$		0.53		Ω
I_{LSW}	Switch Pin Leakage Current	RUN = Open, $V_{IN} = 65\text{V}$, SW = 0V		0.1	1	μA
I_{SS}	Soft-Start Pin Pull-Up Current	$V_{SS} < 2.5\text{V}$	3	5	6	μA
$t_{INT(SS)}$	Internal Soft-Start Time	SS Pin Floating		0.8		ms

Note 1: Stresses beyond those listed under Absolute Maximum Ratings may cause permanent damage to the device. Exposure to any Absolute Maximum Rating condition for extended periods may affect device reliability and lifetime.

Note 2: The LTC3630A is tested under pulsed load conditions such that $T_J \approx T_A$. The LTC3630AE is guaranteed to meet performance specifications from 0°C to 85°C . Specifications over the -40°C to 125°C operating junction temperature range are assured by design, characterization and correlation with statistical process controls. The LTC3630AI is guaranteed over the -40°C to 125°C operating junction temperature range, the LTC3630AH is guaranteed over the -40°C to 150°C operating junction temperature range and the LTC3630AMP is tested and guaranteed over the -55°C to 150°C operating junction temperature range.

High junction temperatures degrade operating lifetimes; operating lifetime is derated for junction temperatures greater than 125°C . Note that the maximum ambient temperature consistent with these specifications is determined by specific operating conditions in conjunction with board layout, the rated package thermal impedance and other environmental factors.

Note 3: The junction temperature (T_J , in $^\circ\text{C}$) is calculated from the ambient temperature (T_A , in $^\circ\text{C}$) and power dissipation (P_D , in Watts) according to the formula:

$$T_J = T_A + (P_D \cdot \theta_{JA})$$

where θ_{JA} is $43^\circ\text{C}/\text{W}$ for the DFN or $45^\circ\text{C}/\text{W}$ for the MSOP.

ELECTRICAL CHARACTERISTICS

Note that the maximum ambient temperature consistent with these specifications is determined by specific operating conditions in conjunction with board layout, the rated package thermal impedance and other environmental factors.

Note 4: This IC includes over temperature protection that is intended to protect the device during momentary overload conditions. The maximum rated junction temperature will be exceeded when this protection is active. Continuous operation above the specified absolute maximum operating junction temperature may impair device reliability or permanently damage the device. The overtemperature protection level is not production tested.

Note 5: Dynamic supply current is higher due to the gate charge being delivered at the switching frequency. See Applications Information.

Note 6: For application concerned with pin creepage and clearance distances at high voltages, the MSOP package should be used. See Applications Information.

Note 7: At very high input voltages, the minimum output voltage that can be maintained is limited to $V_{IN} - 65V$ if the load current is less than 5mA. Refer to the High Input Voltage Considerations in the Operation section.

TYPICAL PERFORMANCE CHARACTERISTICS

Soft-Start Waveform

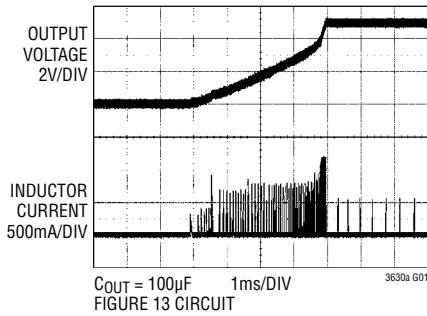

Load Step Transient Response

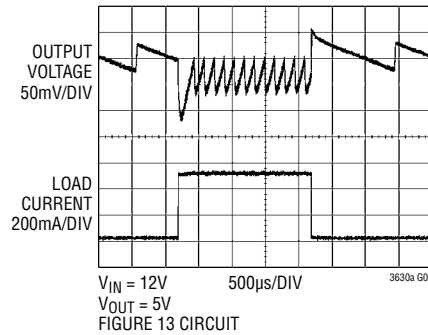

Short-Circuit Response

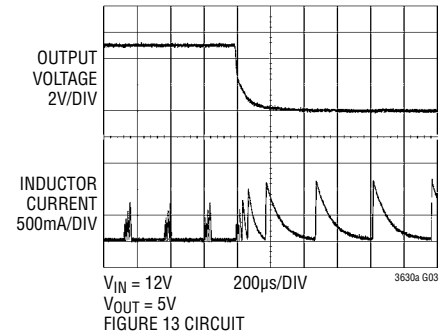

Efficiency and Power Loss vs Load Current, $V_{OUT} = 5V$

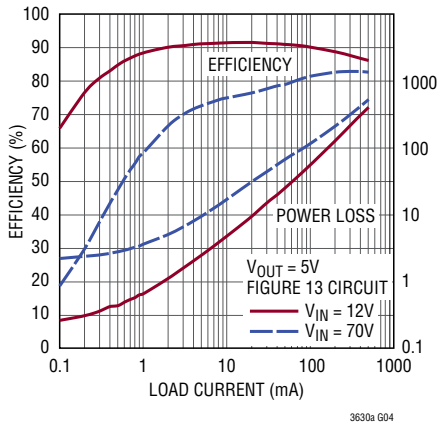

Efficiency and Power Loss vs Load Current, $V_{OUT} = 3.3V$

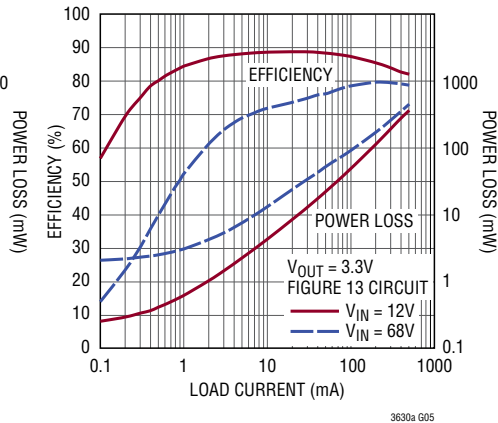

Efficiency and Power Loss vs Load Current, $V_{OUT} = 1.8V$

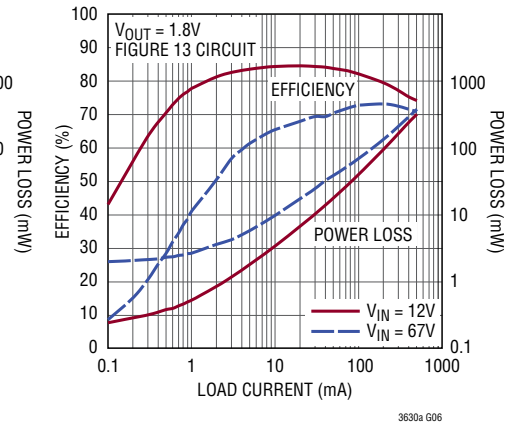

TYPICAL PERFORMANCE CHARACTERISTICS

Efficiency vs Input Voltage

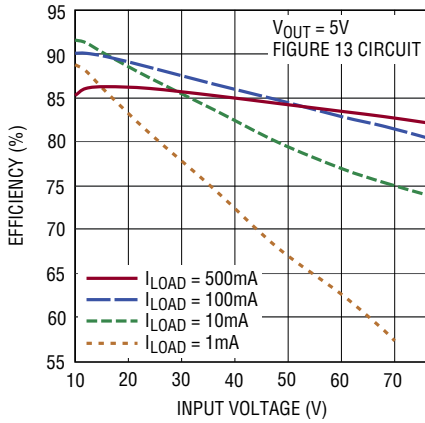

3630a G07

Line Regulation vs Input Voltage

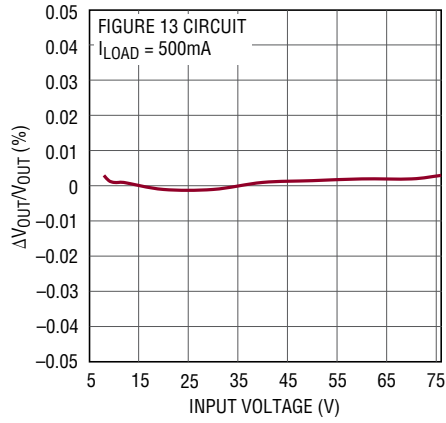

3630a G08

Load Regulation vs Load Current

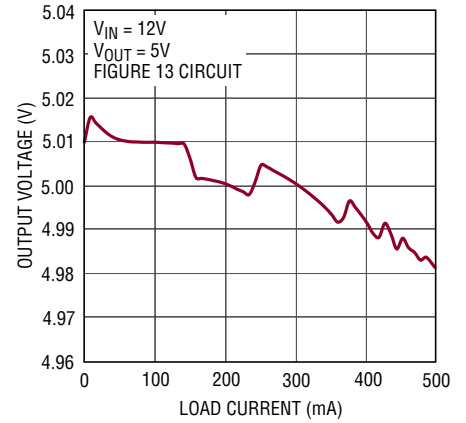

3630a G09

Feedback Comparator Trip Voltage vs Temperature

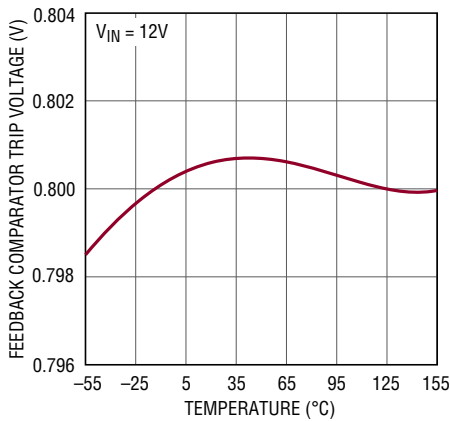

3630a G10

Feedback Comparator Hysteresis vs Temperature

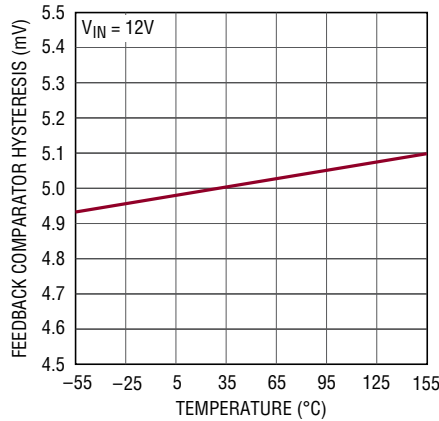

3630a G11

Peak Current Trip Threshold vs Temperature and ISET

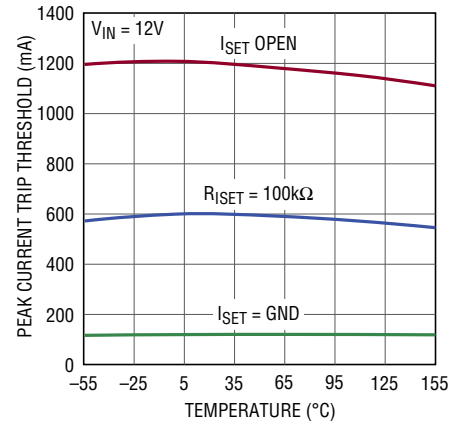

3630a G12

Peak Current Trip Threshold vs RISET

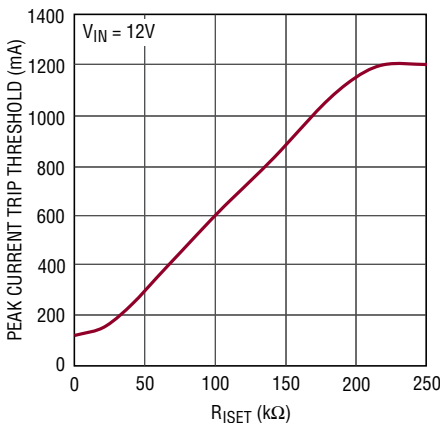

3630a G13

Peak Current Trip Threshold vs Input Voltage

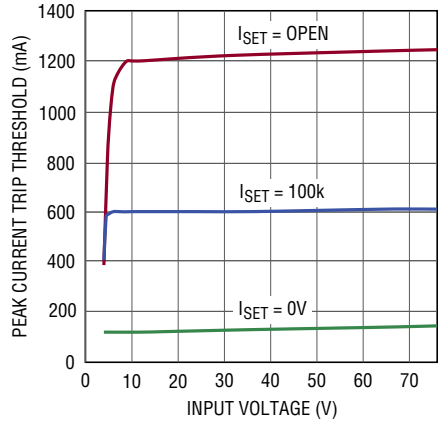

3630a G14

Quiescent VIN Supply Current vs Input Voltage

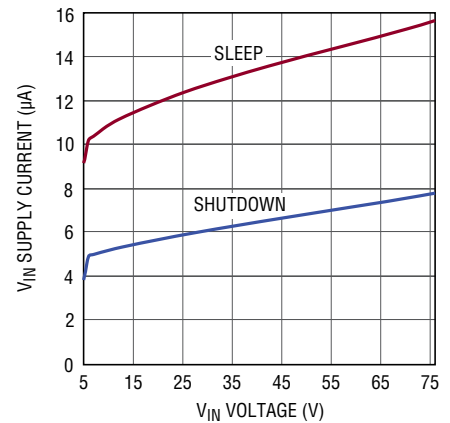

3630a G15

TYPICAL PERFORMANCE CHARACTERISTICS

Quiescent V_{IN} Supply Current vs Temperature

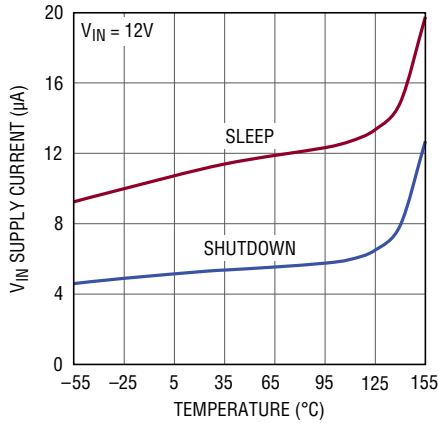

Switch On-Resistance vs Input Voltage

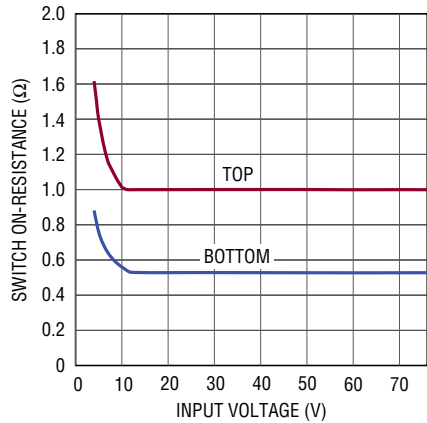

Switch On-Resistance vs Temperature

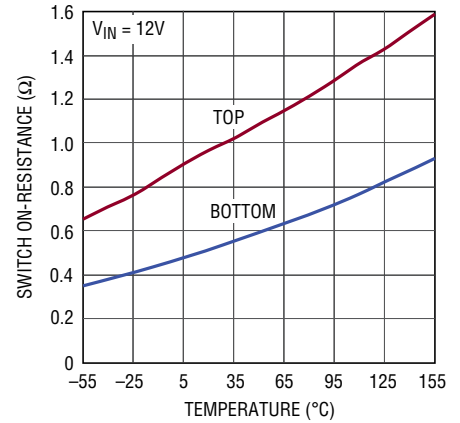

Switch Leakage Current vs Temperature

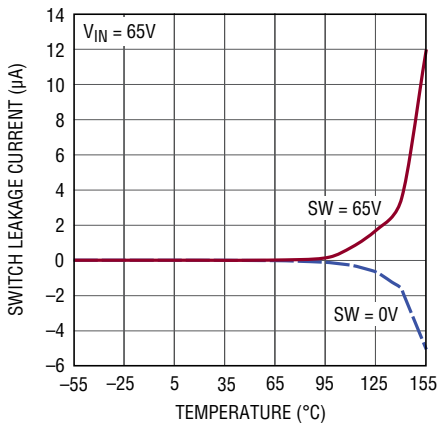

RUN Comparator Threshold Voltage vs Temperature

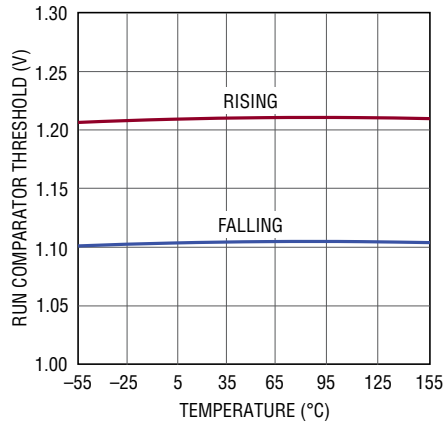

Operating Waveforms

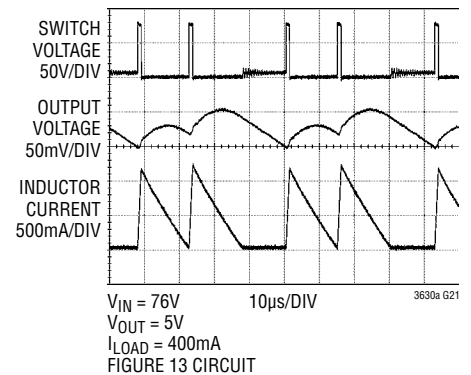

PIN FUNCTIONS

SW (Pin 1): Switch Node Connection to Inductor. This pin connects to the drains of the internal power MOSFET switches.

NC (Pins 2, 4, 13, 15 DHC Package Only): No Internal Connection. Leave these pins open.

V_{IN} (Pin 3): Main Input Supply Pin. A ceramic bypass capacitor should be tied between this pin and GND.

RUN (Pin 5): Run Control Input. A voltage on this pin above 1.21V enables normal operation. Forcing this pin below 0.7V shuts down the LTC3630A, reducing quiescent current to approximately 5 μ A. Optionally, connect to the input supply through a resistor divider to set the under-voltage lockout. An internal 2M resistor and 2 μ A current source pulls this pin up to an internal 5V reference. See Applications Information.

V_{PRG2}, V_{PRG1} (Pins 6, 7): Output Voltage Selection. Short both pins to ground for an external resistive divider programmable output voltage. Short V_{PRG1} to SS and short V_{PRG2} to ground for a 5V output voltage. Short V_{PRG1} to ground and short V_{PRG2} to SS for a 3.3V output voltage. Short both pins to SS for a 1.8V output voltage.

GND (Pins 8, 14, 16, Exposed Pad Pin 17): Ground. The exposed backside pad must be soldered to the PCB ground plane for optimal thermal performance.

V_{FB} (Pin 9): Output Voltage Feedback. When configured for an adjustable output voltage, connect to an external resistive divider to divide the output voltage down for comparison to the 0.8V reference. For the fixed output configuration, directly connect this pin to the output supply.

SS (Pin 10): Soft-Start Control Input. A capacitor to ground at this pin sets the output voltage ramp time. A 50 μ A current initially charges the soft-start capacitor until switching begins, at which time the current is reduced to its nominal value of 5 μ A. The output voltage ramp time from zero to its regulated value is 1ms for every 16.5nF of capacitance from SS to GND. If left floating, the ramp time defaults to an internal 0.8ms soft-start.

I_{SET} (Pin 11): Peak Current Set Input and Voltage Output Ripple Filter. A resistor from this pin to ground sets the peak current comparator threshold. Leave floating for the maximum peak current (1.2A typical) or short to ground for minimum peak current (0.12A typical). The maximum output current is one-half the peak current. The 5 μ A current that is sourced out of this pin when switching, is reduced to 1 μ A in sleep. Optionally, a capacitor can be placed from this pin to GND to trade off efficiency for light load output voltage ripple. See Applications Information.

FBO (Pin 12): Feedback Comparator Output. Connect to the V_{FB} pins of additional LTC3630As to combine the output current. The typical pull-up current is 20 μ A. The typical pull-down impedance is 70 Ω . See Applications Information.

BLOCK DIAGRAM

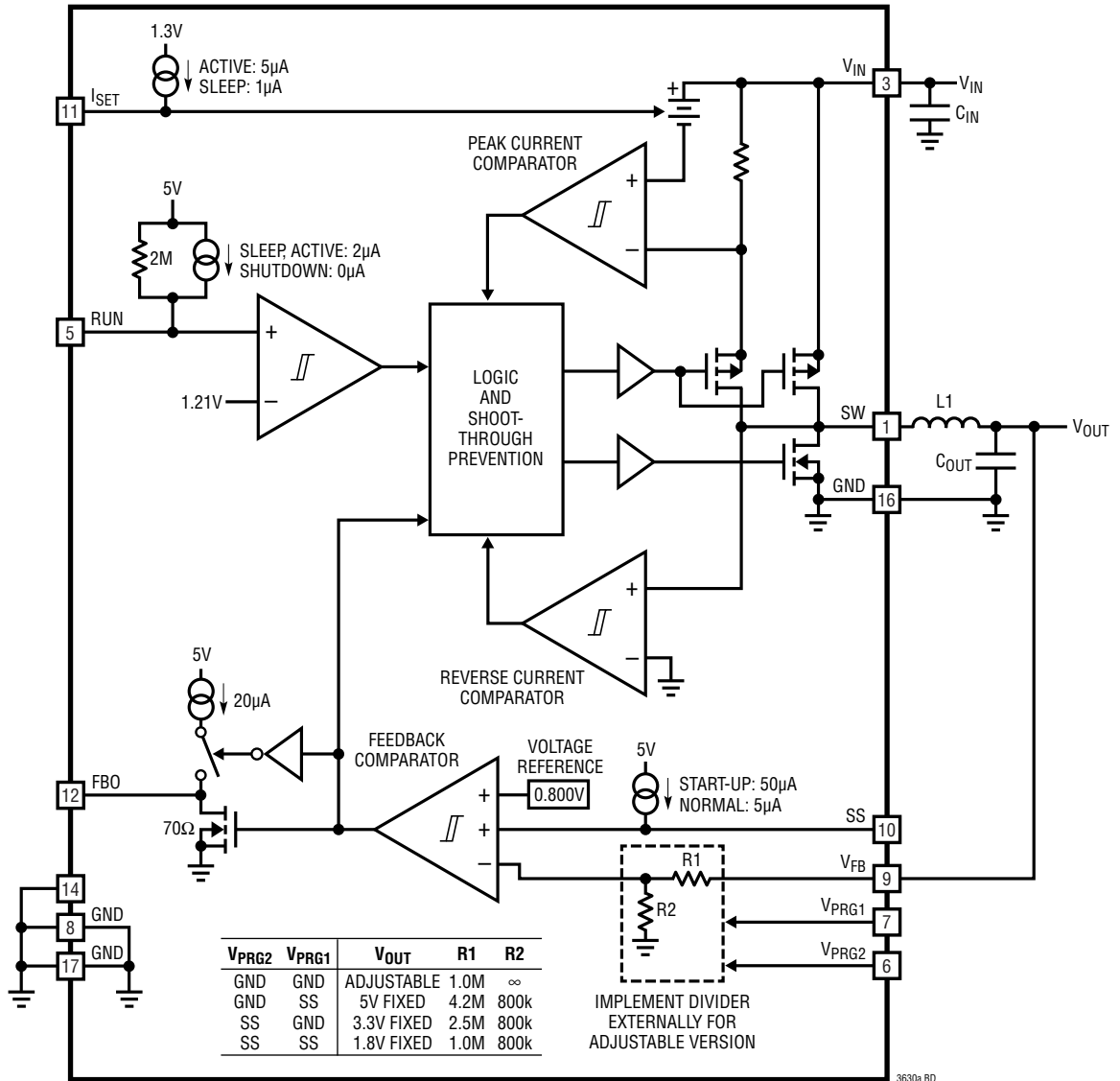

3630a BD

OPERATION (Refer to Block Diagram)

The LTC3630A is a synchronous step-down DC/DC converter with internal power switches that uses Burst Mode control. The low quiescent current and high switching frequency results in high efficiency across a wide range of load currents. Burst Mode operation functions by using short “burst” cycles to switch the inductor current through the internal power MOSFETs, followed by a sleep cycle where the power switches are off and the load current is supplied by the output capacitor. During the sleep cycle, the LTC3630A draws only 12 μ A of supply current. At light loads, the burst cycles are a small percentage of the total cycle time which minimizes the average supply current, greatly improving efficiency. Figure 1 shows an example of Burst Mode operation. The switching frequency and the number of switching cycles during Burst Mode operation are dependent on the inductor value, peak current, load current, input voltage and output voltage.

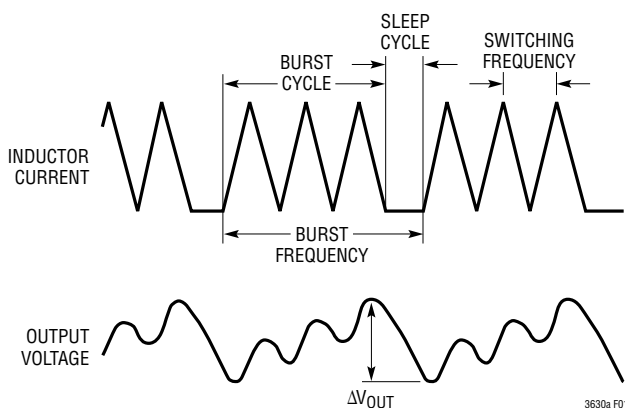

Figure 1. Burst Mode Operation

Main Control Loop

The LTC3630A uses the V_{PRG1} and V_{PRG2} control pins to connect internal feedback resistors to the V_{FB} pin. This enables fixed outputs of 1.8V, 3.3V or 5V without increasing component count, input supply current or exposure to noise on the sensitive input to the feedback comparator. External feedback resistors (adjustable mode) can still be used by connecting both V_{PRG1} and V_{PRG2} to ground.

In adjustable mode the feedback comparator monitors the voltage on the V_{FB} pin and compares it to an internal 800mV reference. If this voltage is greater than the reference, the comparator activates a sleep mode in which the power switches and current comparators are disabled,

reducing the V_{IN} pin supply current to only 12 μ A. As the load current discharges the output capacitor, the voltage on the V_{FB} pin decreases. When this voltage falls 5mV below the 800mV reference, the feedback comparator trips and enables burst cycles.

At the beginning of the burst cycle, the internal high side power switch (P-channel MOSFET) is turned on and the inductor current begins to ramp up. The inductor current increases until either the current exceeds the peak current comparator threshold or the voltage on the V_{FB} pin exceeds 800mV, at which time the high side power switch is turned off and the low side power switch (N-channel MOSFET) turns on. The inductor current ramps down until the reverse current comparator trips, signaling that the current is close to zero. If the voltage on the V_{FB} pin is still less than the 800mV reference, the high side power switch is turned on again and another cycle commences. The average current during a burst cycle will normally be greater than the average load current. For this architecture, the maximum average output current is equal to half of the peak current.

The hysteretic nature of this control architecture results in a switching frequency that is a function of the input voltage, output voltage, and inductor value. This behavior provides inherent short-circuit protection. If the output is shorted to ground, the inductor current will decay very slowly during a single switching cycle. Since the high side switch turns on only when the inductor current is near zero, the LTC3630A inherently switches at a lower frequency during start-up or short-circuit conditions.

Start-Up and Shutdown

If the voltage on the RUN pin is less than 0.7V, the LTC3630A enters a shutdown mode in which all internal circuitry is disabled, reducing the DC supply current to 5 μ A. When the voltage on the RUN pin exceeds 1.21V, normal operation of the main control loop is enabled. The RUN pin comparator has 110mV of internal hysteresis, and therefore must fall below 1.1V to stop switching and disable the main control loop.

An internal 0.8ms soft-start function limits the ramp rate of the output voltage on start-up to prevent excessive input supply droop. If a longer ramp time and consequently less

OPERATION (Refer to Block Diagram)

supply droop is desired, a capacitor can be placed from the SS pin to ground. The $5\mu\text{A}$ current that is sourced out of this pin will create a smooth voltage ramp on the capacitor. If this ramp rate is slower than the internal 0.8ms soft-start, then the output voltage will be limited by the ramp rate on the SS pin instead. The internal and external soft-start functions are reset on start-up and after an undervoltage event on the input supply.

The peak inductor current is not limited by the internal or external soft-start functions; however, placing a capacitor from the I_{SET} pin to ground does provide this capability.

Peak Inductor Current Programming

The peak current comparator nominally limits the peak inductor current to 1.2A. This peak inductor current can be adjusted by placing a resistor from the I_{SET} pin to ground. The $5\mu\text{A}$ current sourced out of this pin through the resistor generates a voltage that adjusts the peak current comparator threshold.

During sleep mode, the current sourced out of the I_{SET} pin is reduced to $1\mu\text{A}$. The I_{SET} current is increased back to $5\mu\text{A}$ on the first switching cycle after exiting sleep mode. The I_{SET} current reduction in sleep mode, along with adding a filtering capacitor, C_{ISET} , from the I_{SET} pin to ground, provides a method of reducing light load output voltage ripple at the expense of lower efficiency and slightly degraded load step transient response.

For applications requiring higher output current, the LTC3630A provides a feedback comparator output pin (FBO) for combining the output current of multiple LTC3630As. By connecting the FBO pin of a “master” LTC3630A to the V_{FB} pin of one or more “slave” LTC3630As, the output currents can be combined to source much more than 500mA.

Dropout Operation

When the input supply decreases toward the output supply, the duty cycle increases to maintain regulation. The P-channel MOSFET top switch in the LTC3630A allows the duty cycle to increase all the way to 100%. At 100% duty cycle, the P-channel MOSFET stays on continuously, providing output current equal to the peak current,

which can be greater than 1A. The power dissipation of the LTC3630A can increase dramatically during dropout operation especially at input voltages less than 10V. The increased power dissipation is due to higher potential output current and increased P-channel MOSFET on-resistance. See the Thermal Considerations section of the Applications Information for a detailed example.

Input Voltage and Overtemperature Protection

When using the LTC3630A, care must be taken not to exceed any of the ratings specified in the Absolute Maximum Ratings section. As an added safeguard, however, the LTC3630A incorporates an overtemperature shutdown feature. If the junction temperature reaches approximately 180°C , the LTC3630A will enter thermal shutdown mode. Both power switches will be turned off and the SW node will become high impedance. After the part has cooled below 160°C , it will restart. The overtemperature level is not production tested.

The LTC3630A can provide a programmable undervoltage lockout which can also serve as a precise input voltage monitor by using a resistive divider from V_{IN} to GND with the tap connected to the RUN pin. Switching is enabled when the RUN pin voltage exceeds 1.21V and is disabled when dropping below 1.1V. Pulling the RUN pin below 700mV forces a low quiescent current shutdown ($5\mu\text{A}$). Furthermore, if the input voltage falls below 3.5V typical (3.7V maximum), an internal undervoltage detector disables switching.

When switching is disabled, the LTC3630A can safely sustain input voltages up to the absolute maximum rating of 80V. Input supply undervoltage events trigger a soft-start reset, which results in a graceful recovery from an input supply transient.

High Input Voltage Considerations

When operating with an input voltage to output voltage differential of more than 65V, a minimum output load current of 5mA is required to maintain a well-regulated output voltage under all operating conditions, including shutdown mode. If this 5mA minimum load is not available, then the minimum output voltage that can be maintained by the LTC3630A is limited to $V_{\text{IN}} - 65\text{V}$.

APPLICATIONS INFORMATION

The basic LTC3630A application circuit is shown on the front page of the data sheet. External component selection is determined by the maximum load current requirement and begins with the selection of the peak current programming resistor, R_{ISET} . The inductor value L can then be determined, followed by capacitors C_{IN} and C_{OUT} .

Peak Current Resistor Selection

The peak current comparator has a guaranteed maximum current limit of 1A (1.2A typical), which guarantees a maximum average current of 500mA. For applications that demand less current, the peak current threshold can be reduced to as little as 100mA (120mA typical). This lower peak current allows the use of lower value, smaller components (input capacitor, output capacitor, and inductor), resulting in lower input supply ripple and a smaller overall DC/DC converter.

The threshold can be easily programmed using a resistor (R_{ISET}) between the I_{SET} pin and ground. The voltage generated on the I_{SET} pin by R_{ISET} and the internal 5 μ A current source sets the peak current. The voltage on the I_{SET} pin is internally limited within the range of 0.1V to 1.0V. The value of resistor for a particular peak current can be selected by using Figure 2 or the following equation:

$$R_{ISET} = I_{PEAK} \cdot 0.2 \cdot 10^6$$

where $100\text{mA} < I_{PEAK} < 1\text{A}$.

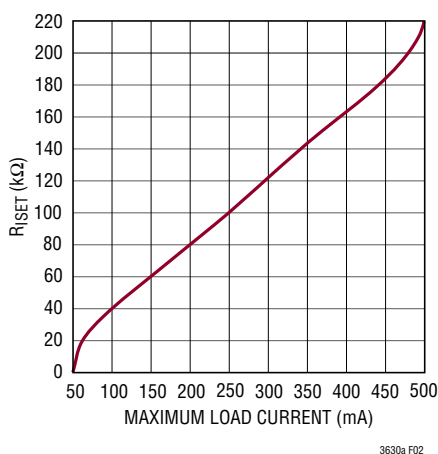

Figure 2. R_{ISET} Selection

The internal 5 μ A current source is reduced to 1 μ A in sleep mode to maximize efficiency and to facilitate a trade-off between efficiency and light load output voltage ripple, as described in the C_{ISET} Selection section of the Applications Information. For maximum efficiency, minimize the capacitance on the I_{SET} pin and place the R_{ISET} resistor as close to the pin as possible.

The typical peak current is internally limited to be within the range of 120mA to 1.2A. Shorting the I_{SET} pin to ground programs the current limit to 120mA, and leaving it float sets the current limit to the maximum value of 1.2A. When selecting this resistor value, be aware that the maximum average output current for this architecture is limited to half of the peak current. Therefore, be sure to select a value that sets the peak current with enough margin to provide adequate load current under all conditions. Selecting the peak current to be 2.2 times greater than the maximum load current is a good starting point for most applications.

Inductor Selection

The inductor, input voltage, output voltage, and peak current determine the switching frequency during a burst cycle of the LTC3630A. For a given input voltage, output voltage, and peak current, the inductor value sets the switching frequency during a burst cycle when the output is in regulation. Generally, switching between 50kHz and 250kHz yields high efficiency, and 200kHz is a good first choice for many applications. The inductor value can be determined by the following equation:

$$L = \left(\frac{V_{OUT}}{f \cdot I_{PEAK}} \right) \cdot \left(1 - \frac{V_{OUT}}{V_{IN}} \right)$$

The variation in switching frequency during a burst cycle with input voltage and inductance is shown in Figure 3. For lower values of I_{PEAK} , multiply the frequency in Figure 3 by $1.2\text{A}/I_{PEAK}$.

An additional constraint on the inductor value is the LTC3630A's 150ns minimum on-time of the high side switch. Therefore, in order to keep the current in the inductor well-controlled, the inductor value must be chosen so that

3630afc

APPLICATIONS INFORMATION

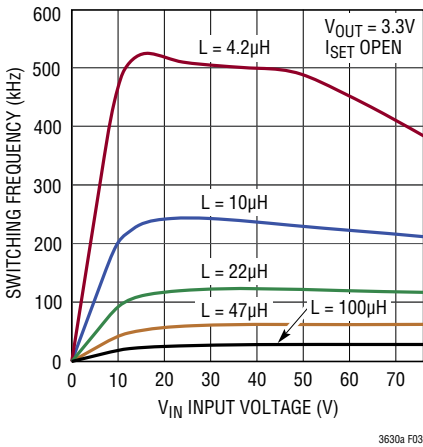

Figure 3. Switching Frequency for $V_{OUT} = 3.3V$

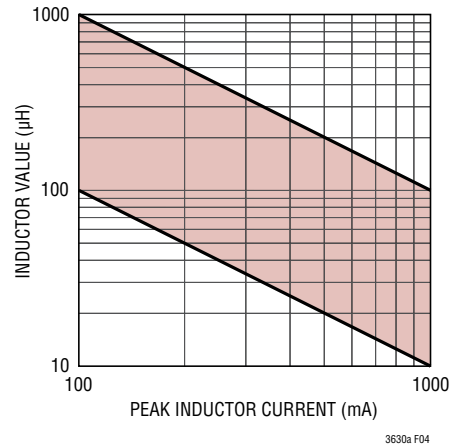

Figure 4. Recommended Inductor Values for Maximum Efficiency

it is larger than a minimum value which can be computed as follows:

$$L > \frac{V_{IN(MAX)} \cdot t_{ON(MIN)}}{I_{PEAK}} \cdot 1.2$$

where $V_{IN(MAX)}$ is the maximum input supply voltage when switching is enabled, $t_{ON(MIN)}$ is 150ns, I_{PEAK} is the peak current, and the factor of 1.2 accounts for typical inductor tolerance and variation over temperature. Inductor values that violate the above equation will cause the peak current to overshoot and permanent damage to the part may occur.

Although the above equation provides the minimum inductor value, higher efficiency is generally achieved with a larger inductor value, which produces a lower switching frequency. The inductor value chosen should also be large enough to keep the inductor current from going very negative which is more of a concern at higher V_{OUT} (>~12V). For a given inductor type, however, as inductance is increased, DC resistance (DCR) also increases. Higher DCR translates into higher copper losses and lower current rating, both of which place an upper limit on the inductance. The recommended range of inductor values for small surface mount inductors as a function of peak current is shown in Figure 4. The values in this range are a good compromise between the trade-offs discussed above. For applications where board area is not a limiting factor, inductors with larger cores can be used, which extends the recommended range of Figure 4 to larger values.

Inductor Core Selection

Once the value for L is known, the type of inductor must be selected. High efficiency converters generally cannot afford the core loss found in low cost powdered iron cores, forcing the use of the more expensive ferrite cores. Actual core loss is independent of core size for a fixed inductor value but is very dependent of the inductance selected. As the inductance increases, core losses decrease. Unfortunately, increased inductance requires more turns of wire and therefore copper losses will increase.

Ferrite designs have very low core losses and are preferred at high switching frequencies, so design goals can concentrate on copper loss and preventing saturation. Ferrite core material saturates “hard,” which means that inductance collapses abruptly when the peak design current is exceeded. This results in an abrupt increase in inductor ripple current and consequently output voltage ripple. Do not allow the core to saturate!

Different core materials and shapes will change the size/current and price/current relationship of an inductor. Toroid or shielded pot cores in ferrite or permalloy materials are small and do not radiate energy but generally cost more than powdered iron core inductors with similar characteristics. The choice of which style inductor to use mainly depends on the price versus size requirements and any radiated field/EMI requirements. New designs for surface mount inductors are available from Coiltronics, Coilcraft, TDK, Toko, and Sumida.

APPLICATIONS INFORMATION

C_{IN} and C_{OUT} Selection

The input capacitor, C_{IN} , is needed to filter the trapezoidal current at the source of the top high side MOSFET. C_{IN} should be sized to provide the energy required to charge the inductor without causing a large decrease in input voltage (ΔV_{IN}). The relationship between C_{IN} and ΔV_{IN} is given by:

$$C_{IN} > \frac{L \cdot I_{PEAK}^2}{2 \cdot V_{IN} \cdot \Delta V_{IN}}$$

It is recommended to use a larger value for C_{IN} than calculated by the above equation since capacitance decreases with applied voltage. In general, a 4.7 μ F X7R ceramic capacitor is a good choice for C_{IN} in most LTC3630A applications.

To minimize large ripple voltage, a low ESR input capacitor sized for the maximum RMS current should be used. RMS current is given by:

$$I_{RMS} = I_{OUT(MAX)} \cdot \frac{V_{OUT}}{V_{IN}} \cdot \sqrt{\frac{V_{IN}}{V_{OUT}} - 1}$$

This formula has a maximum at $V_{IN} = 2V_{OUT}$, where $I_{RMS} = I_{OUT}/2$. This simple worst-case condition is commonly used for design because even significant deviations do not offer much relief. Note that ripple current ratings from capacitor manufacturers are often based only on 2000 hours of life which makes it advisable to further derate the capacitor, or choose a capacitor rated at a higher temperature than required. Several capacitors may also be paralleled to meet size or height requirements in the design.

The output capacitor, C_{OUT} , filters the inductor's ripple current and stores energy to satisfy the load current when the LTC3630A is in sleep. The output ripple has a lower limit of $V_{OUT}/160$ due to the 5mV typical hysteresis of the feedback comparator. The time delay of the comparator adds an additional ripple voltage that is a function of the load current. During this delay time, the LTC3630A continues to switch and supply current to the output. The output ripple can be approximated by:

$$\Delta V_{OUT} \approx \left(\frac{I_{PEAK}}{2} - I_{LOAD} \right) \cdot \frac{4 \cdot 10^{-6}}{C_{OUT}} + \frac{V_{OUT}}{160}$$

The output ripple is a maximum at no load and approaches lower limit of $V_{OUT}/160$ at full load. Choose the output capacitor C_{OUT} to limit the output voltage ripple ΔV_{OUT} using the following equation:

$$C_{OUT} \geq \frac{I_{PEAK} \cdot 2 \cdot 10^{-6}}{\Delta V_{OUT} - \frac{V_{OUT}}{160}}$$

The value of the output capacitor must be large enough to accept the energy stored in the inductor without a large change in output voltage during a single switching cycle.

Setting this voltage step equal to 1% of the output voltage, the output capacitor must be:

$$C_{OUT} > 50 \cdot L \cdot \left(\frac{I_{PEAK}}{V_{OUT}} \right)^2$$

Typically, a capacitor that satisfies the voltage ripple requirement is adequate to filter the inductor ripple. To avoid overheating, the output capacitor must also be sized to handle the ripple current generated by the inductor. The worst-case ripple current in the output capacitor is given by $I_{RMS} = I_{PEAK}/2$. Multiple capacitors placed in parallel may be needed to meet the ESR and RMS current handling requirements.

Dry tantalum, special polymer, aluminum electrolytic, and ceramic capacitors are all available in surface mount packages. Special polymer capacitors offer very low ESR but have lower capacitance density than other types. Tantalum capacitors have the highest capacitance density but it is important only to use types that have been surge tested for use in switching power supplies. Aluminum electrolytic capacitors have significantly higher ESR but can be used in cost-sensitive applications provided that consideration is given to ripple current ratings and long-term reliability. Ceramic capacitors have excellent low ESR characteristics but can have high voltage coefficient and audible piezoelectric effects. The high quality factor (Q) of ceramic capacitors in series with trace inductance can also lead to significant input voltage ringing.

APPLICATIONS INFORMATION

Ceramic Capacitors and Audible Noise

Higher value, lower cost ceramic capacitors are now becoming available in smaller case sizes. Their high ripple current, high voltage rating, and low ESR make them ideal for switching regulator applications. However, care must be taken when these capacitors are used at the input and output. When a ceramic capacitor is used at the input and the power is supplied by a wall adapter through long wires, a load step at the output can induce ringing at the input, V_{IN} . At best, this ringing can couple to the output and be mistaken as loop instability. At worst, a sudden inrush of current through the long wires can potentially cause a voltage spike at V_{IN} large enough to damage the part.

For application with inductive source impedance, such as a long wire, an electrolytic capacitor or a ceramic capacitor with a series resistor may be required in parallel with C_{IN} to dampen the ringing of the input supply. Figure 5 shows this circuit and the typical values required to dampen the ringing.

Ceramic capacitors are also piezoelectric sensitive. The LTC3630A's burst frequency depends on the load current, and in some applications at light load the LTC3630A can excite the ceramic capacitor at audio frequencies, generating audible noise. If the noise is unacceptable, use a high performance tantalum or electrolytic capacitor at the output.

Output Voltage Programming

The LTC3630A has three fixed output voltage modes that can be selected with the V_{PRG1} and V_{PRG2} pins and an adjustable mode. The fixed output modes use an internal feedback divider which enables higher efficiency, higher noise immunity, and lower output voltage ripple for 5V, 3.3V and 1.8V applications. To select the fixed 5V output

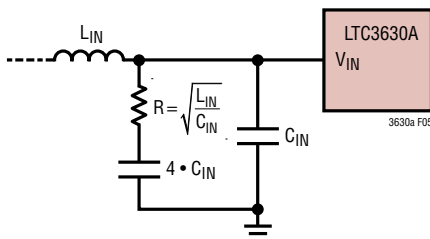

Figure 5. Series RC to Reduce V_{IN} Ringing

voltage, connect V_{PRG1} to SS and V_{PRG2} to GND. For 3.3V, connect V_{PRG1} to GND and V_{PRG2} to SS. For 1.8V, connect both V_{PRG1} and V_{PRG2} to SS. For any of the fixed output voltage options, directly connect the V_{FB} pin to V_{OUT} .

For the adjustable output mode ($V_{PRG1} = 0V$, $V_{PRG2} = 0V$), the output voltage is set by an external resistive divider according to the following equation:

$$V_{OUT} = 0.8V \cdot \left(1 + \frac{R1}{R2} \right)$$

The resistive divider allows the V_{FB} pin to sense a fraction of the output voltage as shown in Figure 6. The output voltage can range from 0.8V to V_{IN} . Be careful to keep the divider resistors very close to the V_{FB} pin to minimize the trace length and noise pick-up on the sensitive V_{FB} signal.

To minimize the no-load supply current, resistor values in the megohm range may be used; however, large resistor values should be used with caution. The feedback divider is the only load current when in shutdown. If PCB leakage current to the output node or switch node exceeds the load current, the output voltage will be pulled up. In normal operation, this is generally a minor concern since the load current is much greater than the leakage.

To avoid excessively large values of R1 in high output voltage applications ($V_{OUT} \geq 10V$), a combination of external and internal resistors can be used to set the output voltage. This has an additional benefit of increasing the noise immunity on the V_{FB} pin. Figure 7 shows the LTC3630A with the V_{FB} pin configured for a 5V fixed output with an external divider to generate a higher output voltage. The internal 5M resistance appears in parallel with R2, and the value of R2 must be adjusted accordingly. R2 should be chosen to be less than 200k to keep the output voltage variation less than 1% due to the tolerance of the LTC3630A's internal resistor.

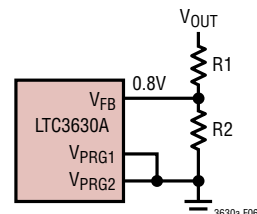

Figure 6. Setting the Output Voltage with External Resistors

APPLICATIONS INFORMATION

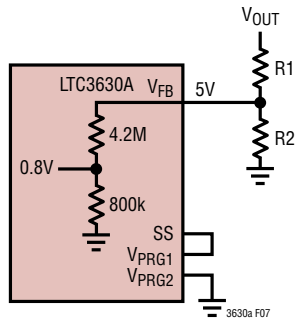

Figure 7. Setting the Output Voltage with External and Internal Resistors

RUN Pin and External Input Undervoltage Lockout

The RUN pin has two different threshold voltage levels. Pulling the RUN pin below 0.7V puts the LTC3630A into a low quiescent current shutdown mode ($I_Q \sim 5\mu\text{A}$). When the RUN pin is greater than 1.21V, the controller is enabled. Figure 8 shows examples of configurations for driving the RUN pin from logic.

The RUN pin can alternatively be configured as a precise undervoltage (UVLO) lockout on the V_{IN} supply with a resistive divider from V_{IN} to ground. A simple resistive divider can be used as shown in Figure 9 to meet specific V_{IN} voltage requirements.

The current that flows through the R3-R4 divider will directly add to the shutdown, sleep, and active current of the LTC3630A, and care should be taken to minimize the impact of this current on the overall efficiency of the

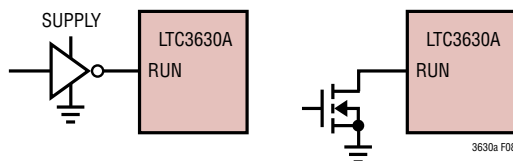

Figure 8. RUN Pin Interface to Logic

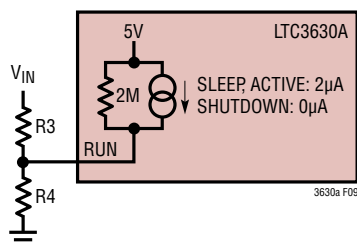

Figure 9. Adjustable UV Lockout

application circuit. To keep the variation of the rising V_{IN} UVLO threshold to less than 5% due to the internal pull-up circuitry, the following equations should be used to calculate R3 and R4:

$$R3 \leq \frac{\text{Rising } V_{IN} \text{ UVLO Threshold}}{40\mu\text{A}}$$

$$R4 = \frac{R3 \cdot 1.21\text{V}}{\text{Rising } V_{IN} \text{ UVLO Threshold} - 1.21\text{V} + R3 \cdot 4\mu\text{A}}$$

The falling UVLO threshold will be about 10% lower than the rising V_{IN} UVLO threshold due to the 110mV hysteresis of the RUN comparator.

For applications that do not require a precise UVLO, the RUN pin can be left floating. In this configuration, the UVLO threshold is limited to the internal V_{IN} UVLO thresholds as shown in the Electrical Characteristics table.

Be aware that the RUN pin cannot be allowed to exceed its absolute maximum rating of 6V. To keep the voltage on the RUN pin from exceeding 6V, the following relation should be satisfied:

$$V_{IN(\text{MAX})} < 4.5 \cdot \text{Rising } V_{IN} \text{ UVLO Threshold}$$

To support a $V_{IN(\text{MAX})}$ greater than 4.5x the external UVLO threshold, an external 4.7V Zener diode should be used in parallel with R4. See Figure 11.

Soft-Start

Soft-start is implemented by ramping the effective reference voltage from 0V to 0.8V. To increase the duration of soft-start, place a capacitor from the SS pin to ground. An internal 5 μA pull-up current will charge this capacitor. The value of the soft-start capacitor can be calculated by the following equation:

$$C_{SS} = \text{Soft-Start Time} \cdot \frac{5\mu\text{A}}{0.35\text{V}}$$

The minimum soft-start time is limited to the internal soft-start timer of 0.8ms. When the LTC3630A detects a fault condition (input supply undervoltage or overtemperature) or when the RUN pin falls below 1.1V, the SS pin is quickly pulled to ground and the internal soft-start timer is reset. This ensures an orderly restart when using an external soft-start capacitor.

APPLICATIONS INFORMATION

Note that the soft-start capacitor may not be the limiting factor in the output voltage ramp. The maximum output current, which is equal to half the peak current, must charge the output capacitor from 0V to its regulated value. For small peak currents or large output capacitors, this ramp time can be significant. Therefore, the output voltage ramp time from 0V to the regulated V_{OUT} value is limited to a minimum of:

$$\text{Ramp Time} \geq \frac{2 \cdot C_{OUT}}{I_{PEAK}} V_{OUT}$$

C_{ISET} Selection

Once the peak current resistor, R_{ISET} , and inductor are selected to meet the load current and frequency requirements, an optional capacitor, C_{ISET} , can be added in parallel with R_{ISET} . This will boost efficiency at mid-loads and reduce the output voltage ripple dependency on load current at the expense of slightly degraded load step transient response.

The peak inductor current is controlled by the voltage on the I_{SET} pin. Current out of the I_{SET} pin is 5 μ A while the LTC3630A is switching and is reduced to 1 μ A during sleep mode. The I_{SET} current will return to 5 μ A on the first cycle after sleep mode. Placing a parallel RC from the I_{SET} pin to ground filters the I_{SET} voltage as the LTC3630A enters and exits sleep mode which in turn will affect the output voltage ripple, efficiency and load step transient performance.

In general, when R_{ISET} is greater than 120k a C_{ISET} capacitor in the 100pF to 200pF range will improve most performance parameters. When R_{ISET} is less than 100k, the capacitance on the I_{SET} pin should be minimized.

Higher Current Applications

For applications that require more than 500mA, the LTC3630A provides a feedback comparator output pin (FBO) for driving additional LTC3630As. When the FBO pin of a “master” LTC3630A is connected to the V_{FB} pin of one or more “slave” LTC3630As, the master controls the burst cycle of the slaves.

Figure 10 shows an example of a 5V, 1A regulator using two LTC3630As. The master is configured for a 5V fixed output with external soft-start and the V_{IN} UVLO level is set by the RUN pin. Since the slaves are directly controlled

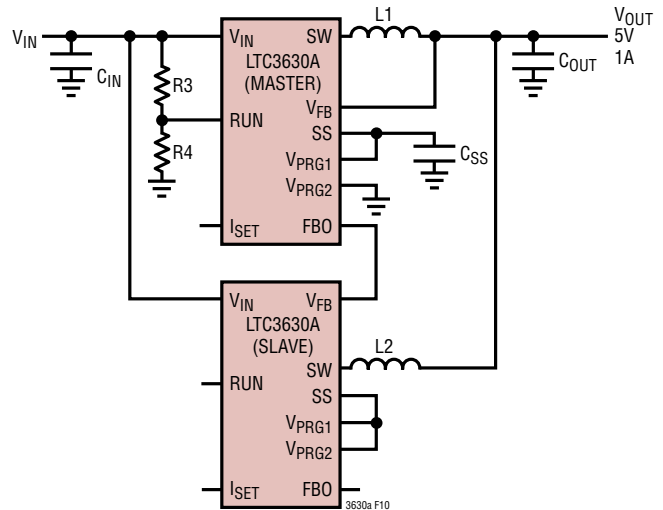

Figure 10. 5V, 1A Regulator

by the master, the SS pin of the slave should have minimal capacitance and the RUN pin of the slave should be floating. Furthermore, slaves should be configured for a 1.8V fixed output ($V_{PRG1} = V_{PRG2} = SS$) to set the V_{FB} pin threshold at 1.8V. The inductors L1 and L2 do not necessarily have to be the same, but should both meet the criteria described above in the Inductor Selection section.

Efficiency Considerations

The efficiency of a switching regulator is equal to the output power divided by the input power times 100%. It is often useful to analyze individual losses to determine what is limiting the efficiency and which change would produce the most improvement. Efficiency can be expressed as:

$$\text{Efficiency} = 100\% - (L1 + L2 + L3 + \dots)$$

where L1, L2, etc. are the individual losses as a percentage of input power.

Although all dissipative elements in the circuit produce losses, two main sources usually account for most of the losses: V_{IN} operating current and I^2R losses. The V_{IN} operating current dominates the efficiency loss at very low load currents whereas the I^2R loss dominates the efficiency loss at medium to high load currents.

1. The V_{IN} operating current comprises two components: The DC supply current as given in the electrical characteristics and the internal MOSFET gate charge currents.

APPLICATIONS INFORMATION

The gate charge current results from switching the gate capacitance of the internal power MOSFET switches. Each time the gate is switched from high to low to high again, a packet of charge, ΔQ , moves from V_{IN} to ground. The resulting $\Delta Q/dt$ is the current out of V_{IN} that is typically larger than the DC bias current.

- I^2R losses are calculated from the resistances of the internal switches, R_{SW} and external inductor R_L . When switching, the average output current flowing through the inductor is “chopped” between the high side PMOS switch and the low side NMOS switch. Thus, the series resistance looking back into the switch pin is a function of the top and bottom switch $R_{DS(ON)}$ values and the duty cycle ($DC = V_{OUT}/V_{IN}$) as follows:

$$R_{SW} = (R_{DS(ON)TOP})DC + (R_{DS(ON)BOT}) \cdot (1 - DC)$$

The $R_{DS(ON)}$ for both the top and bottom MOSFETs can be obtained from the Typical Performance Characteristics curves. Thus, to obtain the I^2R losses, simply add R_{SW} to R_L and multiply the result by the square of the average output current:

$$I^2R \text{ Loss} = I_O^2(R_{SW} + R_L)$$

Other losses, including C_{IN} and C_{OUT} ESR dissipative losses and inductor core losses, generally account for less than 2% of the total power loss.

Thermal Considerations

In most applications, the LTC3630A does not dissipate much heat due to its high efficiency. But, in applications where the LTC3630A is running at high ambient temperature with low supply voltage and high duty cycles, such as dropout, the heat dissipated may exceed the maximum junction temperature of the part.

To prevent the LTC3630A from exceeding the maximum junction temperature, the user will need to do some thermal analysis. The goal of the thermal analysis is to determine whether the power dissipated exceeds the maximum junction temperature of the part. The temperature rise from ambient to junction is given by:

$$T_R = P_D \cdot \theta_{JA}$$

where P_D is the power dissipated by the regulator and θ_{JA} is the thermal resistance from the junction of the die to the ambient temperature.

The junction temperature is given by:

$$T_J = T_A + T_R$$

Generally, the worst-case power dissipation is in dropout at low input voltage. In dropout, the LTC3630A can provide a DC current as high as the full 1.2A peak current to the output. At low input voltage, this current flows through a higher resistance MOSFET, which dissipates more power.

As an example, consider the LTC3630A in dropout at an input voltage of 5V, a load current of 500mA and an ambient temperature of 85°C. From the Typical Performance graphs of Switch On-Resistance, the $R_{DS(ON)}$ of the top switch at $V_{IN} = 5V$ and 100°C is approximately 1.9Ω. Therefore, the power dissipated by the part is:

$$P_D = (I_{LOAD})^2 \cdot R_{DS(ON)} = (500mA)^2 \cdot 1.9\Omega = 0.475W$$

For the MSOP package the θ_{JA} is 45°C/W. Thus, the junction temperature of the regulator is:

$$T_J = 85^\circ C + 0.475W \cdot \frac{45^\circ C}{W} = 106.4^\circ C$$

which is below the maximum junction temperature of 150°C.

Note that while the LTC3630A is in dropout, it can provide output current that is equal to the peak current of the part. This can increase the chip power dissipation dramatically and may cause the internal overtemperature protection circuitry to trigger at 180°C and shut down the LTC3630A.

Design Example

As a design example, consider using the LTC3630A in an application with the following specifications: $V_{IN} = 24V$, $V_{IN(MAX)} = 80V$, $V_{OUT} = 3.3V$, $I_{OUT} = 500mA$, $f = 200kHz$. Furthermore, assume for this example that switching should start when V_{IN} is greater than 12V.

First, calculate the inductor value that gives the required switching frequency:

$$L = \left(\frac{3.3V}{200kHz \cdot 1.2A} \right) \cdot \left(1 - \frac{3.3V}{24V} \right) \cong 10\mu H$$

APPLICATIONS INFORMATION

Next, verify that this value meets the L_{MIN} requirement. For this input voltage and peak current, the minimum inductor value is:

$$L_{MIN} = \frac{24V \cdot 150ns}{1.2A} \cong 3\mu H$$

Therefore, the minimum inductor requirement is satisfied and the 10 μ H inductor value may be used.

Next, C_{IN} and C_{OUT} are selected. For this design, C_{IN} should be sized for a current rating of at least:

$$I_{RMS} = 500mA \cdot \frac{3.3V}{24V} \cdot \sqrt{\frac{24V}{3.3V} - 1} \cong 175mA_{RMS}$$

The value of C_{IN} is selected to keep the input from drooping less than 240mV (1%):

$$C_{IN} > \frac{10\mu H \cdot 1.2A^2}{2 \cdot 24V \cdot 240mV} \cong 2.2\mu F$$

C_{OUT} will be selected based on a value large enough to satisfy the output voltage ripple requirement. For a 50mV output ripple, the value of the output capacitor can be calculated from:

$$C_{OUT} > \frac{10\mu H \cdot 1.2A^2}{2 \cdot 3.3V \cdot 50mV} \cong 47\mu F$$

C_{OUT} also needs an ESR that will satisfy the output voltage ripple requirement. The required ESR can be calculated from:

$$ESR < \frac{50mV}{1.2A} \cong 40m\Omega$$

A 47 μ F ceramic capacitor has significantly less ESR than 40m Ω .

Since an output voltage of 3.3V is one of the standard output configurations, the LTC3630A can be configured by connecting V_{PRG1} to ground and V_{PRG2} to the SS pin.

The undervoltage lockout requirement on V_{IN} can be satisfied with a resistive divider from V_{IN} to the RUN pin (refer to Figure 9). Calculate R3 and R4 as follows:

$$R3 = 200k \text{ which is } \leq \frac{12V}{40\mu A}$$

$$R4 = \frac{200k \cdot 1.21V}{12V - 1.21V + 200k \cdot 4\mu A} = 20.9k$$

Choose standard values for R3 = 200k, R4 = 21k. Note that the V_{IN} falling threshold will be 10% less than the rising threshold or 11V.

Since the maximum V_{IN} is more than 4.5x the UVLO threshold, a 4.7V Zener diode in parallel with R4 is required to keep the maximum voltage on the RUN pin less than the absolute maximum of 6V.

The I_{SET} pin should be left open in this example to select maximum peak current (1.2A typical). Figure 11 shows a complete schematic for this design example.

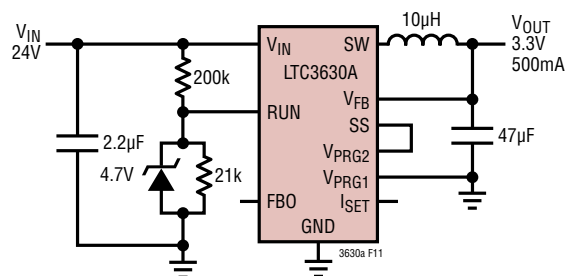

Figure 11. 24V to 3.3V, 500mA Regulator at 200kHz

APPLICATIONS INFORMATION

PC Board Layout Checklist

When laying out the printed circuit board, the following checklist should be used to ensure proper operation of the LTC3630A. Check the following in your layout:

1. Large switched currents flow in the power switches and input capacitor. The loop formed by these components should be as small as possible. A ground plane is recommended to minimize ground impedance.
2. Connect the (+) terminal of the input capacitor, C_{IN} , as close as possible to the V_{IN} pin. This capacitor provides the AC current into the internal power MOSFETs.
3. Keep the switching node, SW, away from all sensitive small signal nodes. The rapid transitions on the switching node can couple to high impedance nodes, in particular V_{FB} , and create increased output ripple.
4. Flood all unused area on all layers with copper except for the area under the inductor. Flooding with copper will reduce the temperature rise of power components. You can connect the copper areas to any DC net (V_{IN} , V_{OUT} , GND, or any other DC rail in your system).

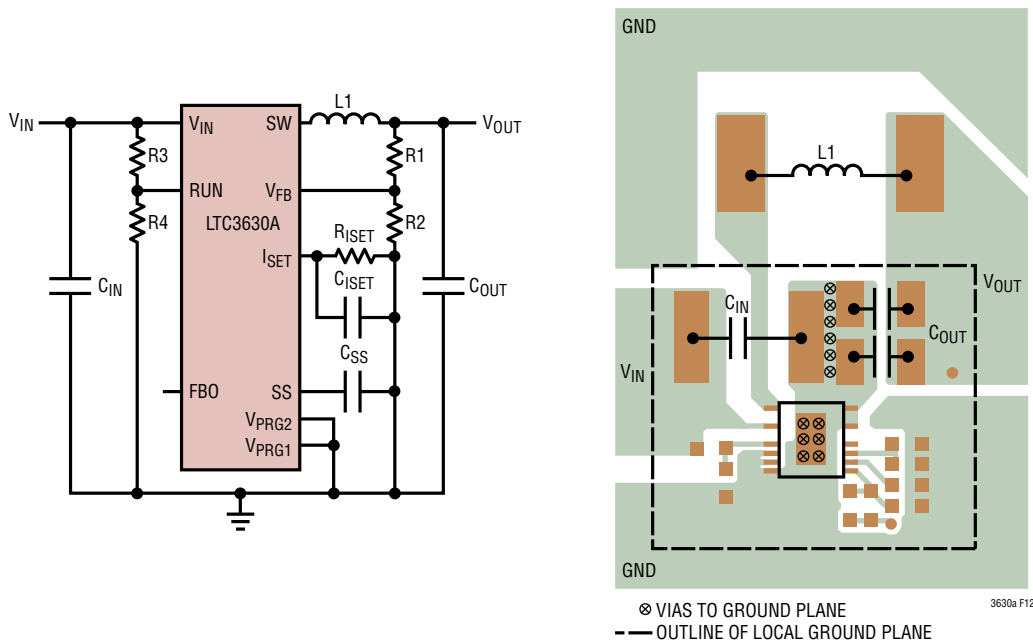

Figure 12. Example PCB Layout

APPLICATIONS INFORMATION

Pin Clearance/Creepage Considerations

The LTC3630A is available in two packages (MSE16 and DHC) both with identical functionality. However, the 0.2mm (minimum space) between pins and paddle on the DHC package may not provide sufficient PC board trace clearance between high and low voltage pins in some higher voltage applications. In applications where clearance is required, the MSE16 package should be used. The MSE16 package has removed pins between all the adjacent high voltage and low voltage pins, providing 0.657mm clearance which will be sufficient for most applications. For more information, refer to the printed circuit board design standards described in IPC-2221 (www.ipc.org).

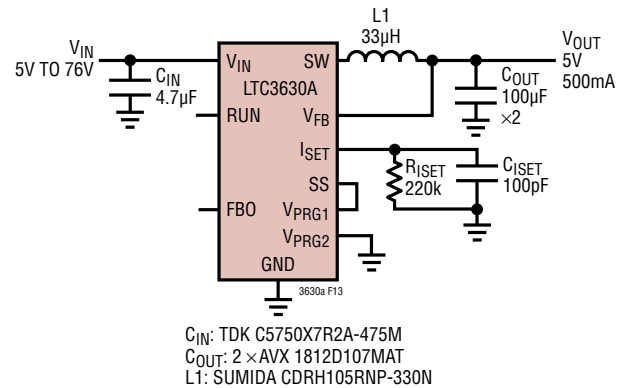
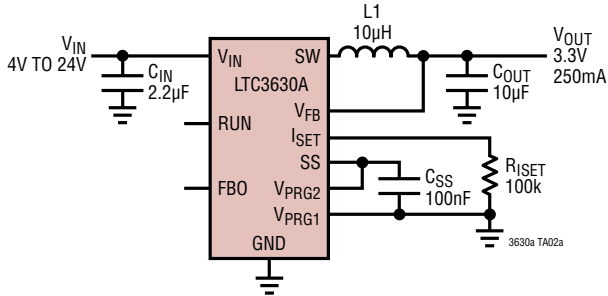

Figure 13. 5V to 76V Input to 5V Output, High Efficiency, 500mA Regulator

TYPICAL APPLICATIONS

**4V to 24V Input to 3.3V Output,
250mA Regulator with External Soft-Start, Small Size**



C_{IN}: MURATA GRM42-2X7R225K25D500
 C_{OUT}: KEMET C1206C206K9PAC
 L1: VISHAY IHLP2020BZ-100M-11

Efficiency and Power Loss vs Load Current

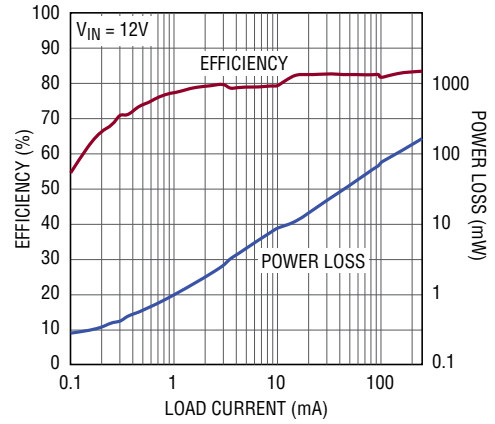

3630a TA02b

4V to 63V Input to -12V Output, Positive-to-Negative Converter

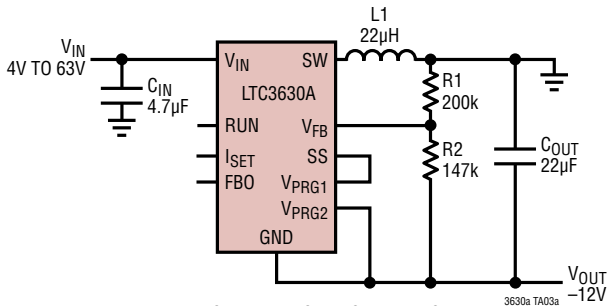

C_{IN}: KEMET C1210C475K5RAC
 C_{OUT}: TDK C4532X7R1C226M
 L1: WÜRTH 744-711-422-0

Maximum Load Current vs Input Voltage

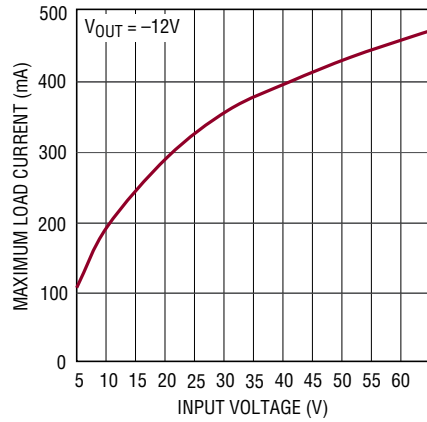

3630a TA03b

TYPICAL APPLICATIONS

5V to 76V Input to 5V Output, 150mA Regulator with 20kHz Minimum Burst Frequency

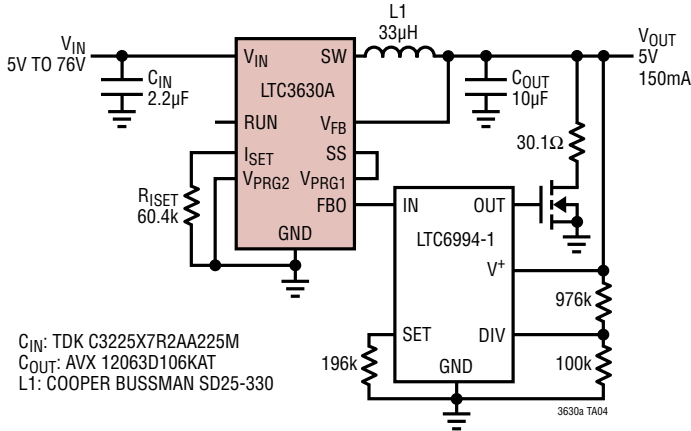

Burst Frequency vs Load Current

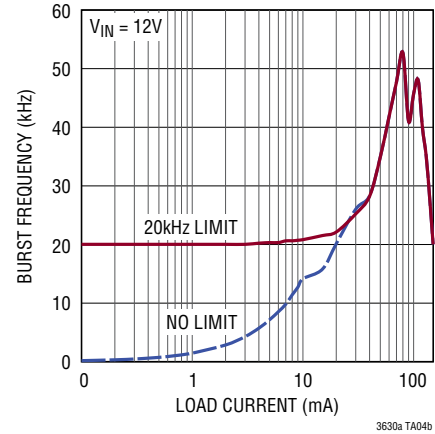

24.5V to 76V Input to 24V Output with 150mA Input Current Limit

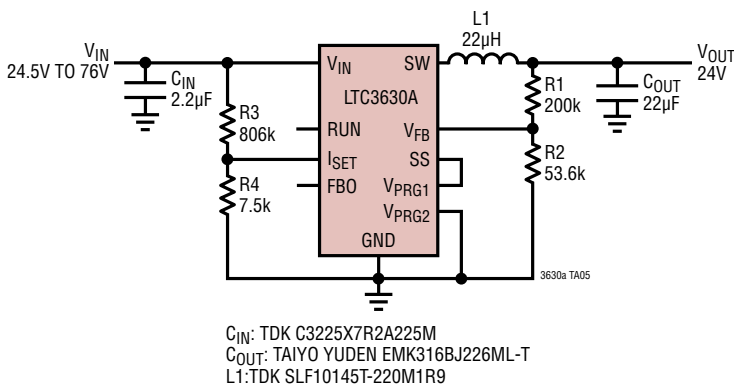

Maximum Input and Load Current vs Input Voltage

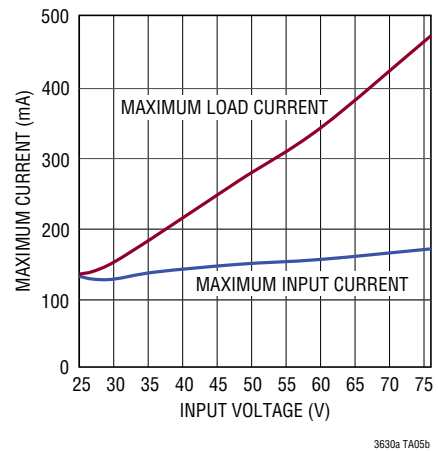

$$\text{INPUT CURRENT LIMIT} \approx \frac{V_{OUT}}{2} \cdot \frac{R4}{R3+R4}$$

$$\text{MAXIMUM LOAD CURRENT} \approx \frac{V_{IN}}{2} \cdot \frac{R4}{R3+R4}$$

PACKAGE DESCRIPTION

Please refer to <http://www.linear.com/designtools/packaging/> for the most recent package drawings.

MSE Package
Variation: MSE16 (12)
16-Lead Plastic MSOP with 4 Pins Removed
Exposed Die Pad
 (Reference LTC DWG # 05-08-1871 Rev D)

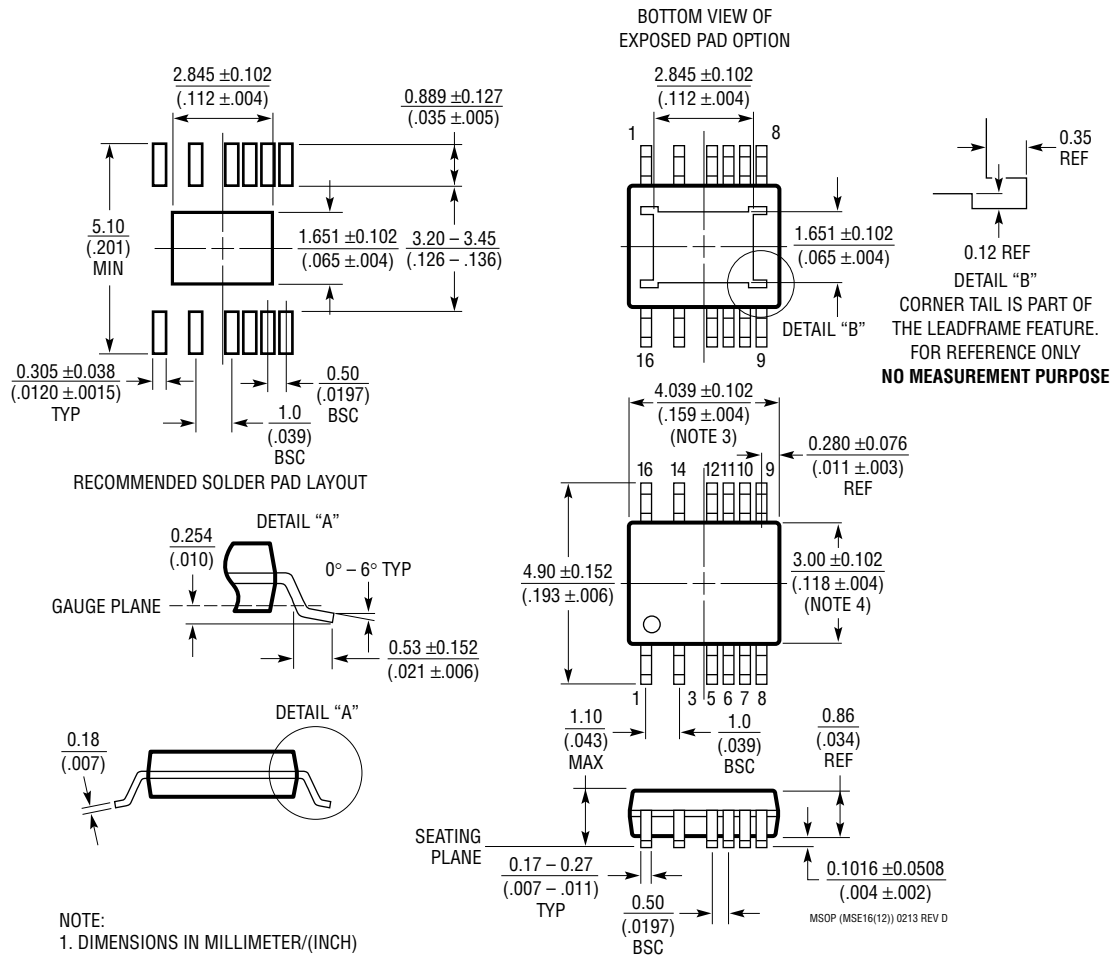

PACKAGE DESCRIPTION

Please refer to <http://www.linear.com/designtools/packaging/> for the most recent package drawings.

DHC Package
16-Lead Plastic DFN (5mm × 3mm)
 (Reference LTC DWG # 05-08-1706 Rev 0)

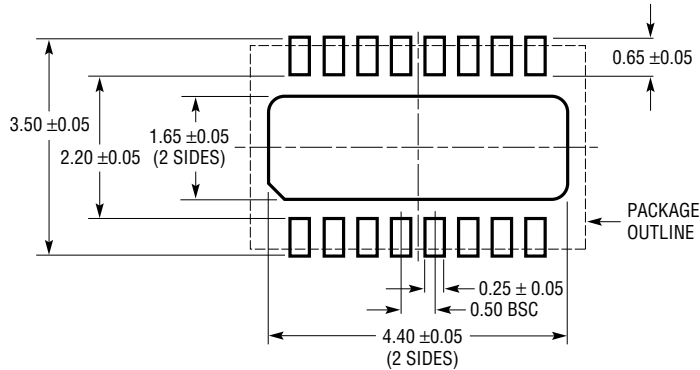

RECOMMENDED SOLDER PAD PITCH AND DIMENSIONS

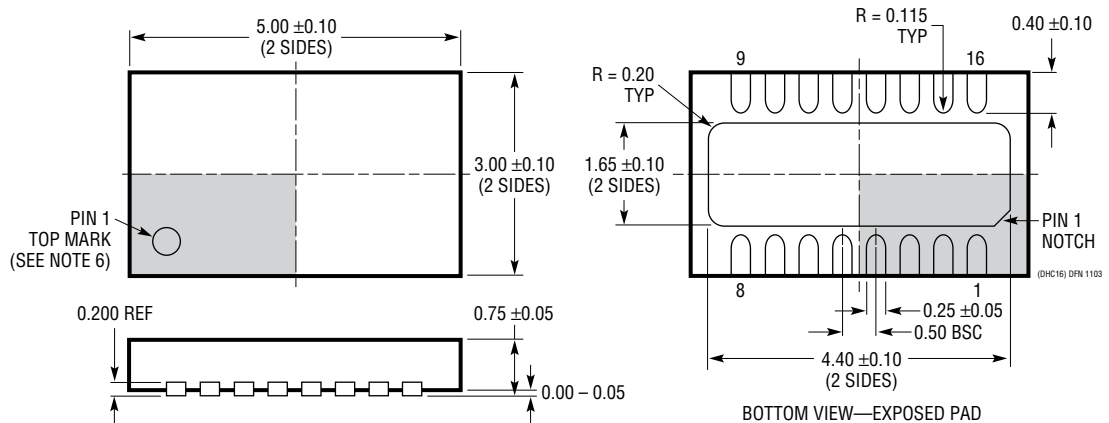

NOTE:

1. DRAWING PROPOSED TO BE MADE VARIATION OF VERSION (WJED-1) IN JEDEC PACKAGE OUTLINE MO-229
2. DRAWING NOT TO SCALE
3. ALL DIMENSIONS ARE IN MILLIMETERS
4. DIMENSIONS OF EXPOSED PAD ON BOTTOM OF PACKAGE DO NOT INCLUDE MOLD FLASH. MOLD FLASH, IF PRESENT, SHALL NOT EXCEED 0.15mm ON ANY SIDE
5. EXPOSED PAD SHALL BE SOLDER PLATED
6. SHADED AREA IS ONLY A REFERENCE FOR PIN 1 LOCATION ON THE TOP AND BOTTOM OF PACKAGE

REVISION HISTORY

REV	DATE	DESCRIPTION	PAGE NUMBER
A	08/13	Removed RUN pin connection from V_{IN} on schematic.	1
B	02/14	Clarified Typical Application	1
C	02/14	Added maximum limits to I_Q specification	3

TYPICAL APPLICATION

4V to 76V Input to 3.3V Output, 500mA Step-Down Converter

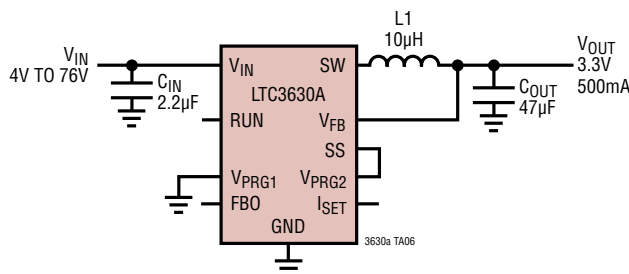

C_{IN}: TDK CGA6N3X7R2A225K
 C_{OUT}: MURATA GCM32ER70J476KE19L
 L1: COILCRAFT MSS1038T-103

RELATED PARTS

PART NUMBER	DESCRIPTION	COMMENTS
LTC3630	65V 500mA Synchronous Step-Down DC/DC Converter	V _{IN} : 4V to 65V, V _{OUT(MIN)} = 0.8V, I _Q = 12µA, I _{SD} = 5µA, 3mm × 5mm DFN-8, MSOP-16E
LTC3642	45V (Transient to 60V) 50mA Synchronous Step-Down DC/DC Converter	V _{IN} : 4.5V to 45V, V _{OUT(MIN)} = 0.8V, I _Q = 12µA, I _{SD} = 3µA, 3mm × 3mm DFN-8, MSOP-8
LTC3631	45V (Transient to 60V) 100mA Synchronous Step-Down DC/DC Converter	V _{IN} : 4.5V to 45V, V _{OUT(MIN)} = 0.8V, I _Q = 12µA, I _{SD} = 3µA, 3mm × 3mm DFN-8, MSOP-8
LTC3632	50V (Transient to 60V) 20mA Synchronous Step-Down DC/DC Converter	V _{IN} : 4.5V to 50V, V _{OUT(MIN)} = 0.8V, I _Q = 12µA, I _{SD} = 3µA, 3mm × 3mm DFN-8, MSOP-8
LTC3103	15V, 300mA Synchronous Step-Down DC/DC Converter with Ultralow Quiescent Current	V _{IN} : 2.5V to 15V, V _{OUT(MIN)} = 0.6V, I _Q = 1.8µA, I _{SD} = 1µA, 3mm × 3mm DFN-10, MSOP-10E
LTC3104	15V, 300mA Synchronous Step-Down DC/DC Converter with Ultralow Quiescent Current and 10mA LDO	V _{IN} : 2.5V to 15V, V _{OUT(MIN)} = 0.6V, I _Q = 2.6µA, I _{SD} = 1µA, 4mm × 3mm DFN-14, MSOP-16E
LT3970	40V, 350mA, 2.2MHz High Efficiency Micropower Step-Down DC/DC Converter with I _Q = 2.5µA	V _{IN} : 4.2V to 40V, V _{OUT(MIN)} = 1.21V, I _Q = 2.5µA, I _{SD} < 1µA, 3mm × 2mm DFN-10, MSOP-10
LT3990	62V, 350mA, 2.2MHz High Efficiency Micropower Step-Down DC/DC Converter with I _Q = 2.5µA	V _{IN} : 4.2V to 62V, V _{OUT(MIN)} = 1.21V, I _Q = 2.5µA, I _{SD} < 1µA, 3mm × 3mm DFN-10, MSOP-16E
LT3971	38V, 1.2A, 2.2MHz High Efficiency Micropower Step-Down DC/DC Converter with I _Q = 2.8µA	V _{IN} : 4.3V to 38V, V _{OUT(MIN)} = 1.19V, I _Q = 2.8µA, I _{SD} < 1µA, 3mm × 3mm DFN-10, MSOP-10E
LT3991	55V, 1.2A, 2.2MHz High Efficiency Micropower Step-Down DC/DC Converter with I _Q = 2.8µA	V _{IN} : 4.3V to 55V, V _{OUT(MIN)} = 1.19V, I _Q = 2.8µA, I _{SD} < 1µA, 3mm × 3mm DFN-10, MSOP-10E
LT3682	36V, 60V _{MAX} , 1A, 2.2MHz High Efficiency Micropower Step-Down DC/DC Converter	V _{IN} : 3.6V to 36V, V _{OUT(MIN)} = 0.8V, I _Q = 75µA, I _{SD} < 1µA, 3mm × 3mm DFN-12
LTC3891	Low I _Q , 60V Synchronous Step-Down Controller	V _{IN} : 4V to 60V, V _{OUT(MIN)} = 0.8V, I _Q = 50µA, I _{SD} = 14µA, 3mm × 4mm QFN-20, TSSOP-20E

Looking for pricing, stock, or lifecycle information?

Click below to explore more details on WIN SOURCE:

 [View LTC3630AEMSE#PBF on WIN SOURCE](#)

 [Linear Technology](#) Information

Optimize Your Supply Chain with WIN SOURCE Solutions

-  Global Sourcing Solution
-  Obsolete Management
-  Cost Control Management
-  Shortage Management
-  Alternative Solution
-  Excess Inventory Management