



THE DATASHEET OF 2SC4131



LOW VCE (sat) 2SC4131

Silicon NPN Epitaxial Planar Transistor

Application : DC-DC Converter, Emergency Lighting Inverter and General Purpose

Absolute maximum ratings (Ta=25°C)

Symbol	Ratings	Unit
V _{CB0}	100	V
V _{CEO}	50	V
V _{EBO}	15	V
I _c	15(Pulse25)	A
I _B	4	A
P _c	60(Tc=25°C)	W
T _j	150	°C
T _{stg}	-55 to +150	°C

Electrical Characteristics (Ta=25°C)

Symbol	Conditions	Ratings	Unit
I _{CB0}	V _{CB} =100V	10max	μA
I _{EBO}	V _{EB} =15V	10max	μA
V _{(BR)CEO}	I _c =25mA	50min	V
h _{FE}	V _{CE} =1V, I _c =5A	60 to 360	
V _{CE(sat)}	I _c =5A, I _B =80mA	0.5max	V
V _{BE(sat)}	I _c =5A, I _B =80mA	1.2max	V
f _r	V _{CE} =12V, I _E =-1A	18typ	MHz
C _{OB}	V _{CB} =10V, f=1MHz	210typ	pF

External Dimensions FM100(TO3PF)

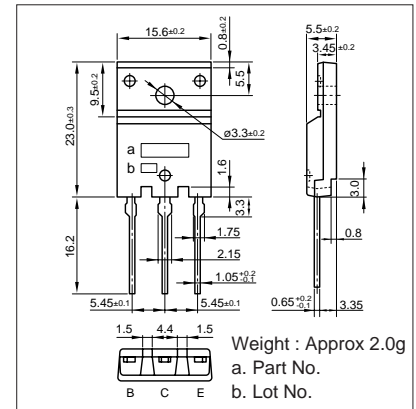

Typical Switching Characteristics (Common Emitter)

V _{CC} (V)	R _L (Ω)	I _c (A)	V _{BB1} (V)	V _{BB2} (V)	I _{B1} (A)	I _{B2} (A)	t _{on} (μs)	t _{stg} (μs)	t _f (μs)
20	4	5	10	-5	0.08	-0.08	0.5typ	2.0typ	0.4typ

I_c-V_{CE} Characteristics (Typical)

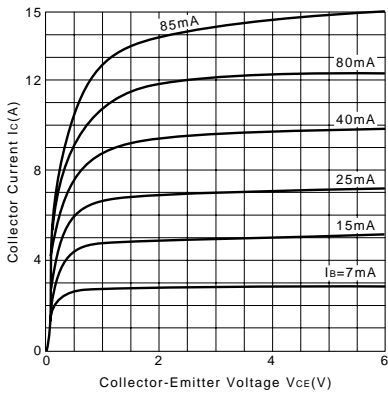

V_{CE(sat)}-I_B Characteristics (Typical)

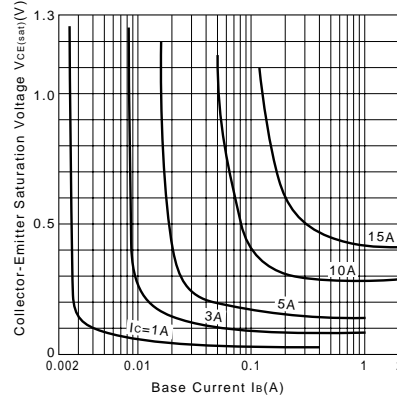

I_c-V_{BE} Temperature Characteristics (Typical)

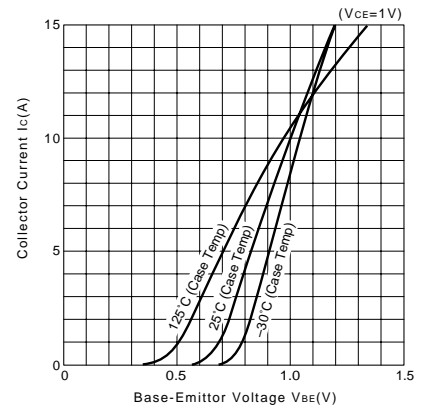

h_{FE}-I_c Characteristics (Typical)

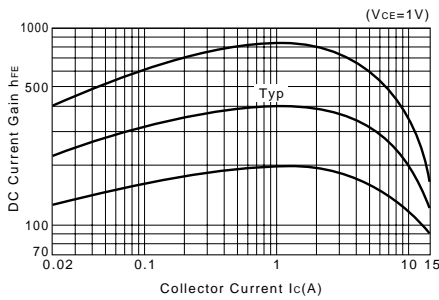

h_{FE}-I_c Temperature Characteristics (Typical)

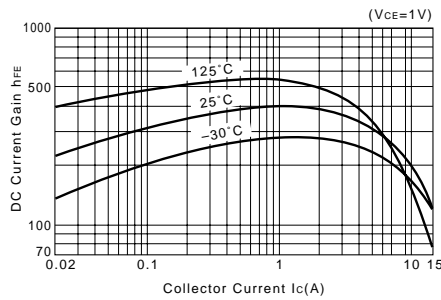

θ_{j-a}-t Characteristics

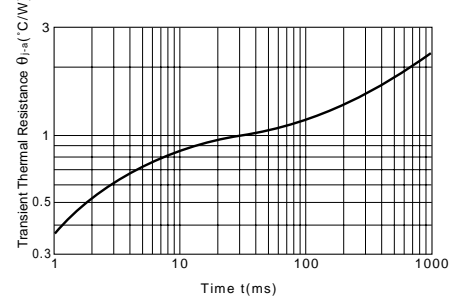

t_{on}•t_{stg}•t_r-I_c Characteristics (Typical)

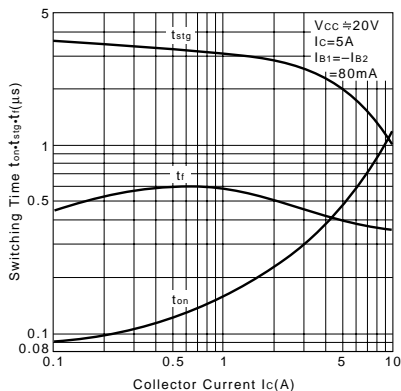

Safe Operating Area (Single Pulse)

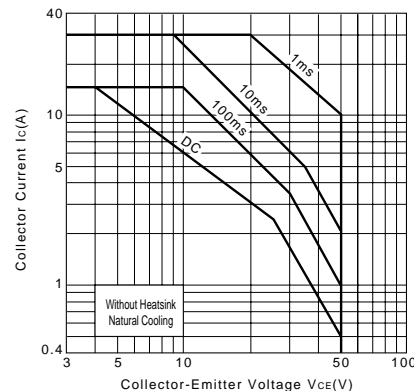

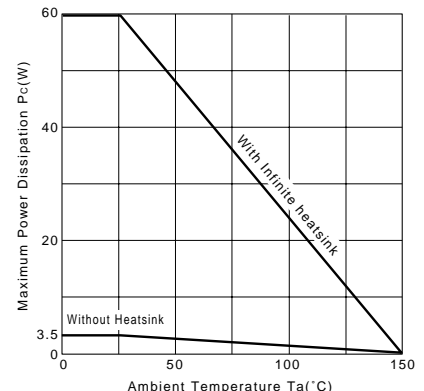

P_c-T_a Derating



Looking for pricing, stock, or lifecycle information?

Click below to explore more details on WIN SOURCE:

-  [View 2SC4131 on WIN SOURCE](#)
-  [Sanken Information](#)

Optimize Your Supply Chain with WIN SOURCE Solutions

-  Global Sourcing Solution
-  Obsolete Management
-  Cost Control Management
-  Shortage Management
-  Alternative Solution
-  Excess Inventory Management