16-Bit Digital Signal Controllers with High-Speed PWM, Op Amps and Advanced Analog Features

Operating Conditions

- 3.0V to 3.6V, -40°C to +85°C, up to 70 MIPS
- 3.0V to 3.6V, -40°C to +125°C, up to 60 MIPS

Core: 16-Bit dsPIC33E CPU

- Code-Efficient (C and Assembly) Architecture
- Two 40-Bit Wide Accumulators
- Single-Cycle (MAC/MPY) with Dual Data Fetch
- Single-Cycle Mixed-Sign MUL plus Hardware Divide
- 32-Bit Multiply Support

Clock Management

- Internal Fast FRC Oscillator with 1% Accuracy
- Programmable PLLs and Oscillator Clock Sources
- Fail-Safe Clock Monitor (FSCM)
- Independent Watchdog Timer (WDT)
- Fast Wake-up and Start-up

Power Management

- Low-Power Management modes (Sleep, Idle, Doze)
- Executing Optimized NOP String with Flash Fetch
- Integrated Power-on Reset and Brown-out Reset
- 0.6 mA/MHz Dynamic Current (typical)
- 30 μ A IPD Current (typical)

High-Speed PWM

- Up to 12 PWM Outputs (six generators)
- Primary Master Time Base Inputs allow Time Base Synchronization from Internal/External Sources
- Dead Time for Rising and Falling Edges
- 7.14 ns PWM Resolution
- PWM Support for:
 - DC/DC, AC/DC, Inverters, PFC, Lighting
 - BLDC, PMSM, ACIM, SRM
- Programmable Fault Inputs
- Flexible Trigger Configurations for ADC Conversions
- Supports PWM Lock, PWM Output Chopping and Dynamic Phase Shifting

Advanced Analog Features

- Two Independent ADC modules:
 - Configurable as 10-bit, 1.1 Msps with four S&H or 12-bit, 500 kpsps with one S&H
 - 11, 13, 18, 30 or 49 analog inputs
- Flexible and Independent ADC Trigger Sources
- Up to Four Op Amp/Comparators with Direct Connection to the ADC module:
 - Additional dedicated comparator
 - Programmable references with 32 voltage points
 - Programmable blanking and filtering
- Charge Time Measurement Unit (CTMU):
 - Supports mTouch™ capacitive touch sensing
 - Provides high-resolution time measurement (1 ns)
 - On-chip temperature measurement

Timers/Output Compare/Input Capture

- 21 General Purpose Timers:
 - Nine 16-bit and up to four 32-bit timers/counters
 - Eight output capture modules configurable as timers/counters
 - PTG module with two configurable timers/counters
 - Two 32-bit Quadrature Encoder Interface (QEI) modules configurable as a timer/counter
- Eight Input Capture modules
- Peripheral Pin Select (PPS) to allow Function Remap
- Peripheral Trigger Generator (PTG) for Scheduling Complex Sequences

Communication Interfaces

- Four Enhanced Addressable UART modules (17.5 Mbps):
 - With support for LIN/J2602 protocols and IrDA®
- Three 3-Wire/4-Wire SPI modules (15 Mbps)
- 25 Mbps Data Rate for Dedicated SPI module (with no PPS)
- Two I²C™ modules (up to 1 Mbps) with SMBus Support
- Two CAN modules (1 Mbps) with CAN 2.0B Support
- Programmable Cyclic Redundancy Check (CRC)
- Codec Interface module (DCI) with I²S Support

Direct Memory Access (DMA)

- 4-Channel DMA with User-Selectable Priority Arbitration
- Peripherals Supported by the DMA Controller include:
 - UART, SPI, ADC, CAN and input capture
 - Output compare and timers

Input/Output

- Sink/Source 15 mA or 10 mA, Pin-Specific for Standard VOH/VOL
- 5V Tolerant Pins
- Selectable Open-Drain, Pull-ups and Pull-Downs
- Up to 5 mA Overvoltage Clamp Current
- Change Notice Interrupts on All I/O Pins
- PPS to allow Function Remap

Qualification and Class B Support

- AEC-Q100 REVG (Grade 1, -40°C to +125°C) Planned
- AEC-Q100 REVG (Grade 0, -40°C to +150°C) Planned
- Class B Safety Library, IEC 60730

Debugger Development Support

- In-Circuit and In-Application Programming
- Three Complex and Five Simple Breakpoints
- IEEE 1149.2 Compatible (JTAG) Boundary Scan
- Trace and Run-Time Watch

dsPIC33EPXXXGM3XX/6XX/7XX

dsPIC33EPXXXGM3XX/6XX/7XX PRODUCT FAMILY

The device names, pin counts, memory sizes and peripheral availability of each device are listed in [Table 1](#). Their pinout diagrams appear on the following pages.

TABLE 1: dsPIC33EPXXXGM3XX/6XX/7XX FAMILY DEVICES

Device	Program Flash Memory (Kbytes)	RAM (Kbytes)	Remappable Peripherals										10-Bit/12-Bit ADC (Channels)	Op Amps/Comparators	CTMU	PTG	PMP	RTCC	I/O Pins	Pins	Packages			
			CAN	16-Bit/32-Bit Timers	Input Capture	Output Compare	Motor Control PWM (Channels)	QEI	UART	SPI ⁽¹⁾	DCI	External Interrupts ⁽²⁾										I ² C™	CRC Generator	ADC
dsPIC33EP128GM304	128	16	0	9/4	8	8	12	2	4	3	1	5	2	1	2	18	4/5	1	Yes	No	No	35	44	TQFP, QFN
dsPIC33EP128GM604			2																					
dsPIC33EP256GM304	256	32	0	9/4	8	8	12	2	4	3	1	5	2	1	2	30	4/5	1	Yes	Yes	Yes	53	64	TQFP, QFN
dsPIC33EP256GM604			2																					
dsPIC33EP512GM304	512	48	0	9/4	8	8	12	2	4	3	1	5	2	1	2	49	4/5	1	Yes	Yes	Yes	85	100/ 121	TQFP, TFBGA
dsPIC33EP512GM604			2																					
dsPIC33EP128GM306	128	16	0	9/4	8	8	12	2	4	3	1	5	2	1	2	30	4/5	1	Yes	Yes	Yes	53	64	TQFP, QFN
dsPIC33EP128GM706			2																					
dsPIC33EP256GM306	256	32	0	9/4	8	8	12	2	4	3	1	5	2	1	2	49	4/5	1	Yes	Yes	Yes	85	100/ 121	TQFP, TFBGA
dsPIC33EP256GM706			2																					
dsPIC33EP512GM306	512	48	0	9/4	8	8	12	2	4	3	1	5	2	1	2	49	4/5	1	Yes	Yes	Yes	85	100/ 121	TQFP, TFBGA
dsPIC33EP512GM706			2																					
dsPIC33EP128GM310	128	16	0	9/4	8	8	12	2	4	3	1	5	2	1	2	49	4/5	1	Yes	Yes	Yes	85	100/ 121	TQFP, TFBGA
dsPIC33EP128GM710			2																					
dsPIC33EP256GM310	256	32	0	9/4	8	8	12	2	4	3	1	5	2	1	2	49	4/5	1	Yes	Yes	Yes	85	100/ 121	TQFP, TFBGA
dsPIC33EP256GM710			2																					
dsPIC33EP512GM310	512	48	0	9/4	8	8	12	2	4	3	1	5	2	1	2	49	4/5	1	Yes	Yes	Yes	85	100/ 121	TQFP, TFBGA
dsPIC33EP512GM710			2																					

Note 1: Only SPI2 and SPI3 are remappable.
2: INT0 is not remappable.

Pin Diagrams

44-Pin TQFP^(1,2)

■ = Pins are up to 5V tolerant

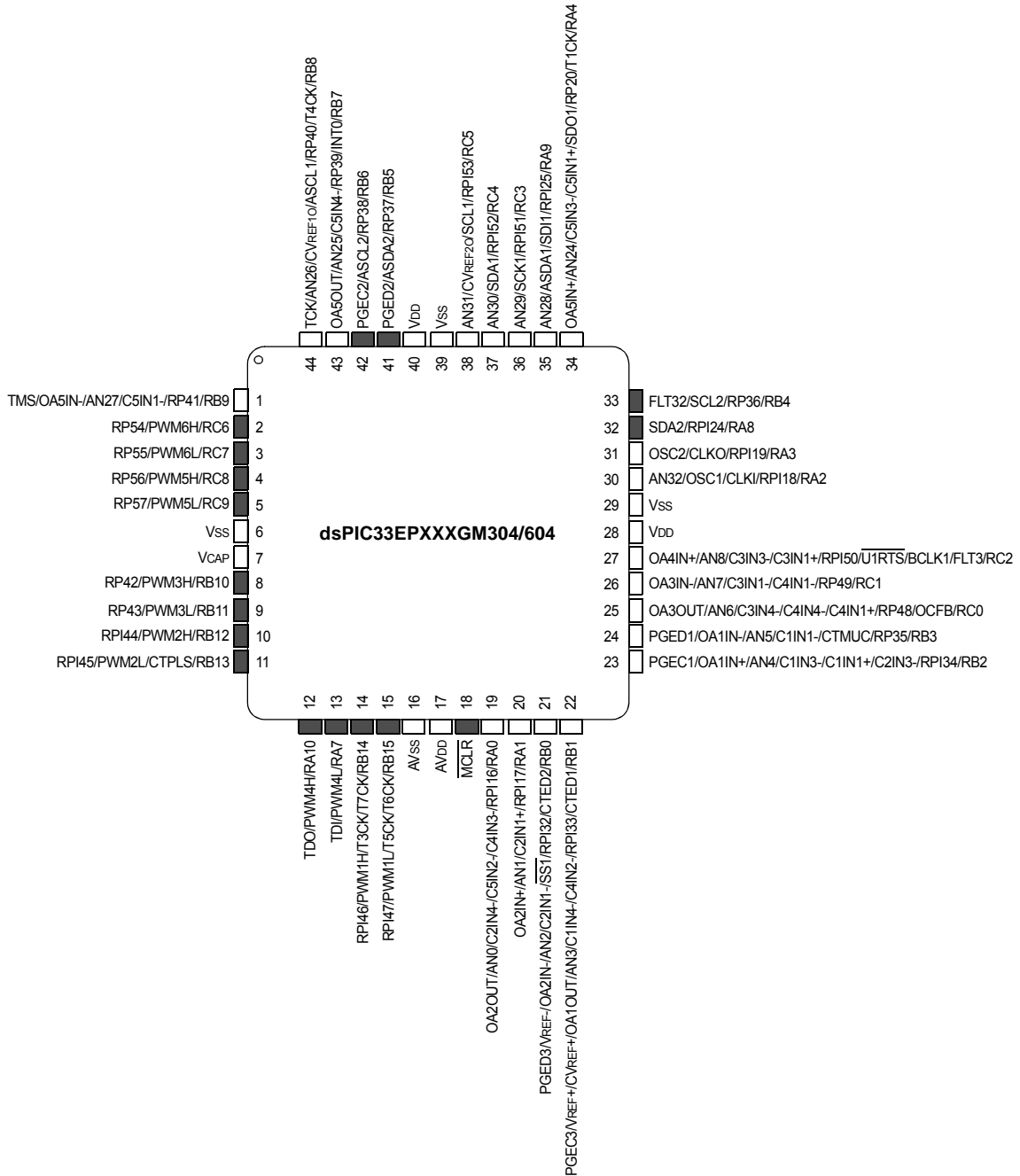

- Note**
- 1: The RPN/RPIn pins can be used by any remappable peripheral with some limitation. See [Section 11.4 "Peripheral Pin Select \(PPS\)"](#) for available peripherals and for information on limitations.
 - 2: Every I/O port pin (RAX-RGx) can be used as a Change Notification pin (CNAX-CNGx). See [Section 11.0 "I/O Ports"](#) for more information.

dsPIC33EPXXXGM3XX/6XX/7XX

Pin Diagrams (Continued)

44-Pin QFN^(1,2,3)

■ = Pins are up to 5V tolerant

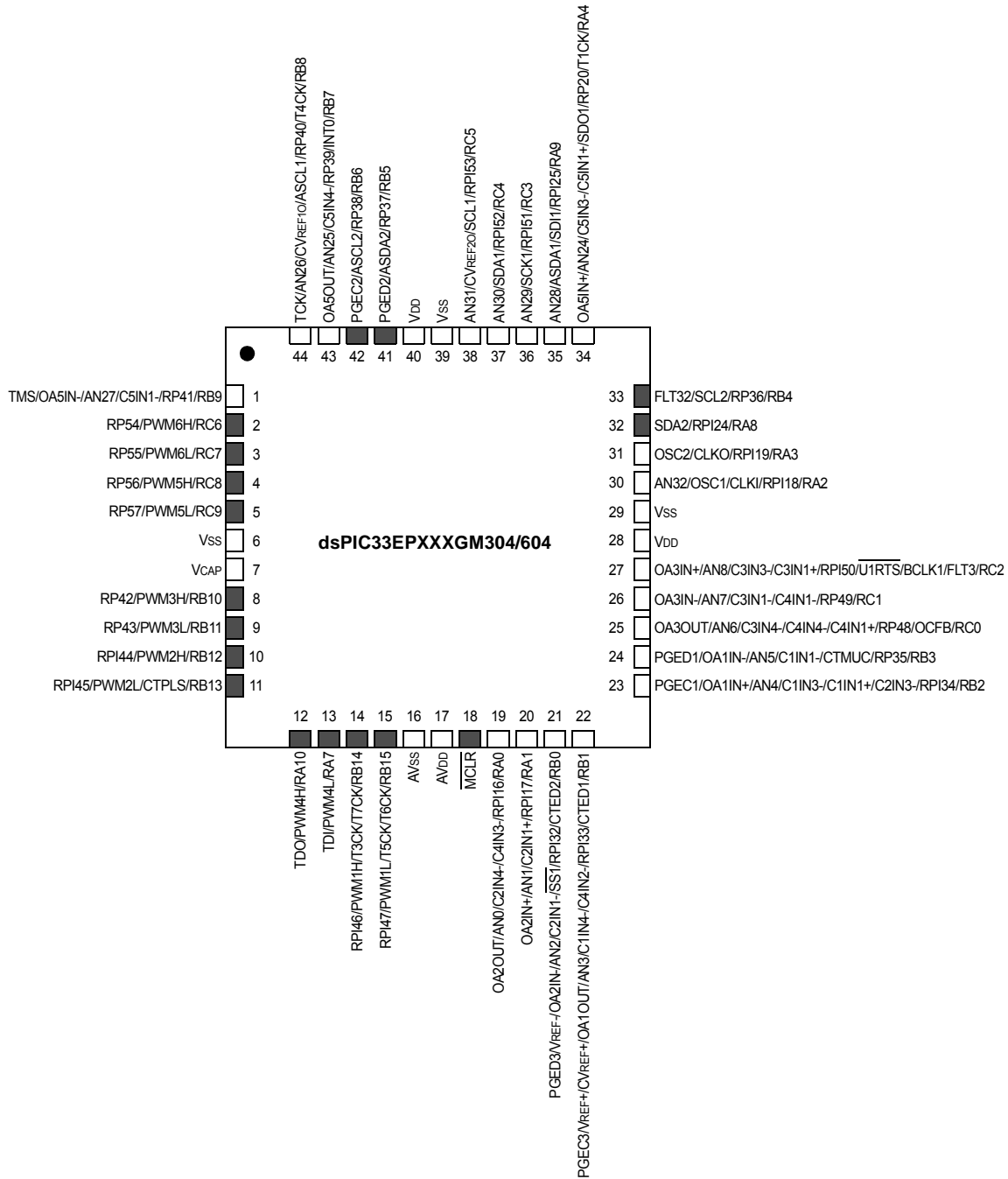

- Note**
- 1: The RPN/RPIN pins can be used by any remappable peripheral with some limitation. See [Section 11.4 “Peripheral Pin Select \(PPS\)”](#) for available peripherals and for information on limitations.
 - 2: Every I/O port pin (RAX-RGX) can be used as a Change Notification pin (CNAX-CNGX). See [Section 11.0 “I/O Ports”](#) for more information.
 - 3: The metal pad at the bottom of the device is not connected to any pins and is recommended to be connected to VSS externally.

dsPIC33EPXXXGM3XX/6XX/7XX

Pin Diagrams (Continued)

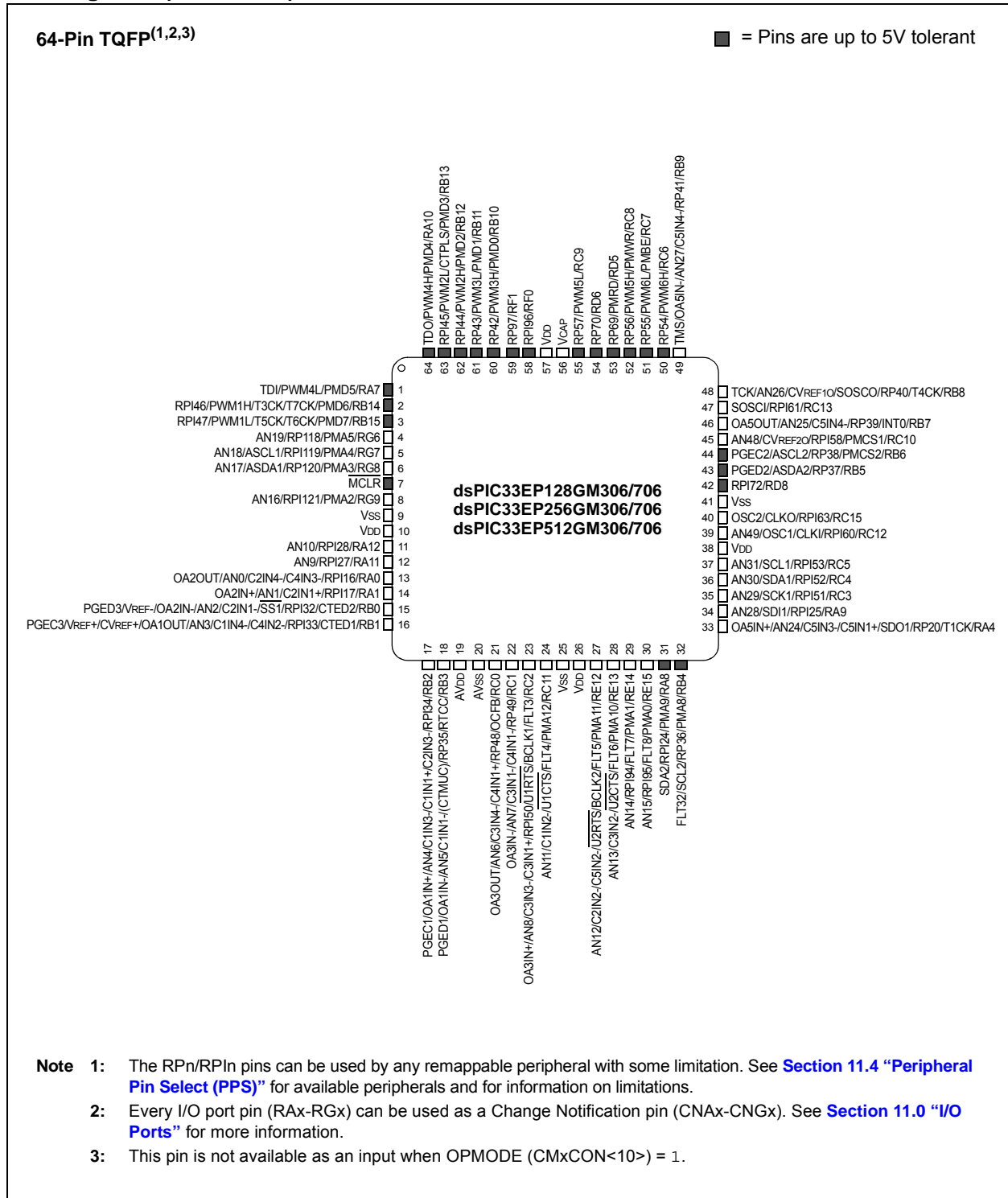

dsPIC33EPXXGM3XX/6XX/7XX

Pin Diagrams (Continued)

64-Pin QFN^(1,2,3,4)

■ = Pins are up to 5V tolerant

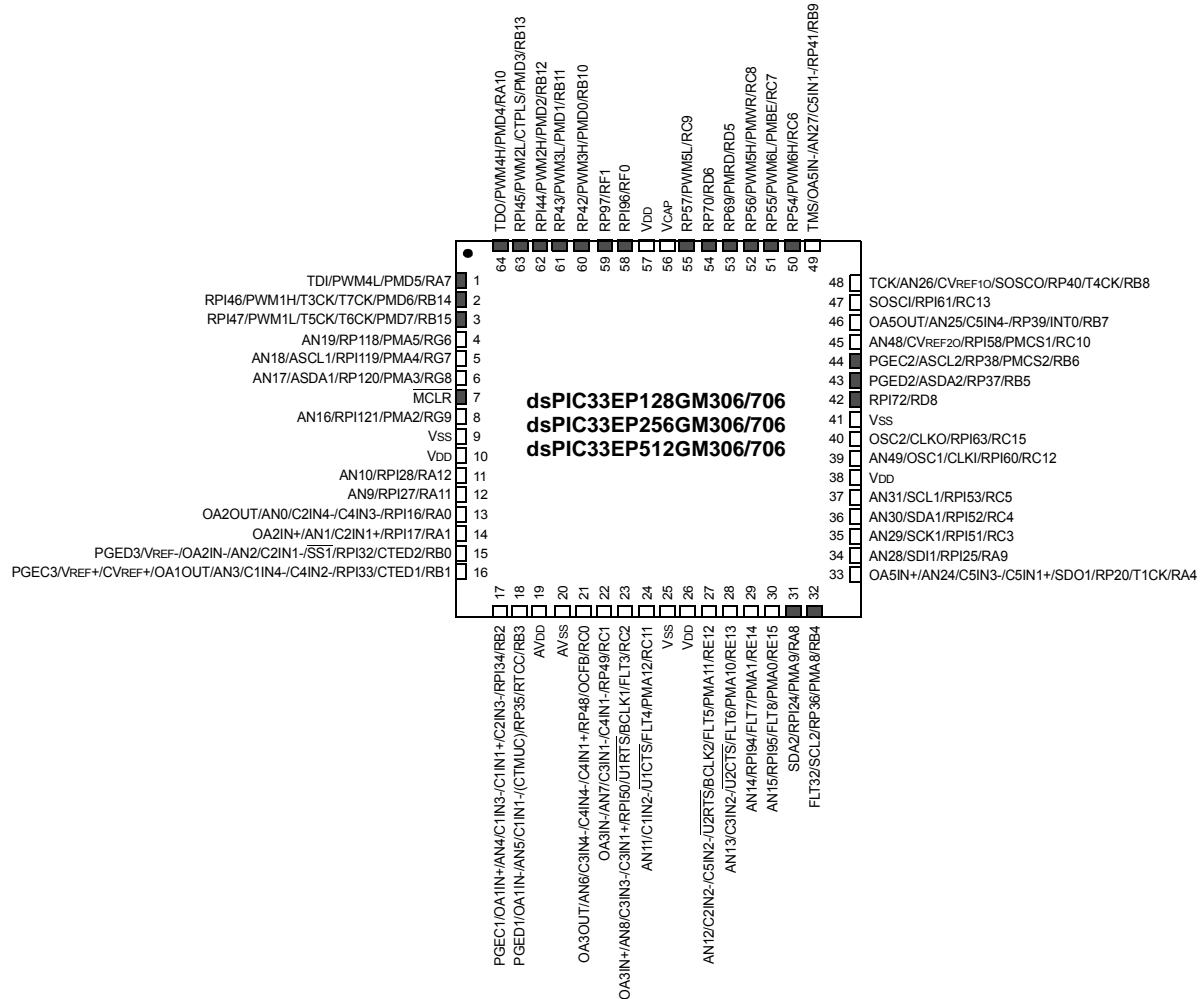

- Note**
- 1: The RPN/RPn pins can be used by any remappable peripheral with some limitation. See [Section 11.4 “Peripheral Pin Select \(PPS\)”](#) for available peripherals and for information on limitations.
 - 2: Every I/O port pin (RAX-RGx) can be used as a Change Notification pin (CNAx-CNGx). See [Section 11.0 “I/O Ports”](#) for more information.
 - 3: This pin is not available as an input when OPMODE (CMxCON<10>) = 1.
 - 4: The metal pad at the bottom of the device is not connected to any pins and is recommended to be connected to Vss externally.

dsPIC33EPXXXGM3XX/6XX/7XX

Pin Diagrams (Continued)

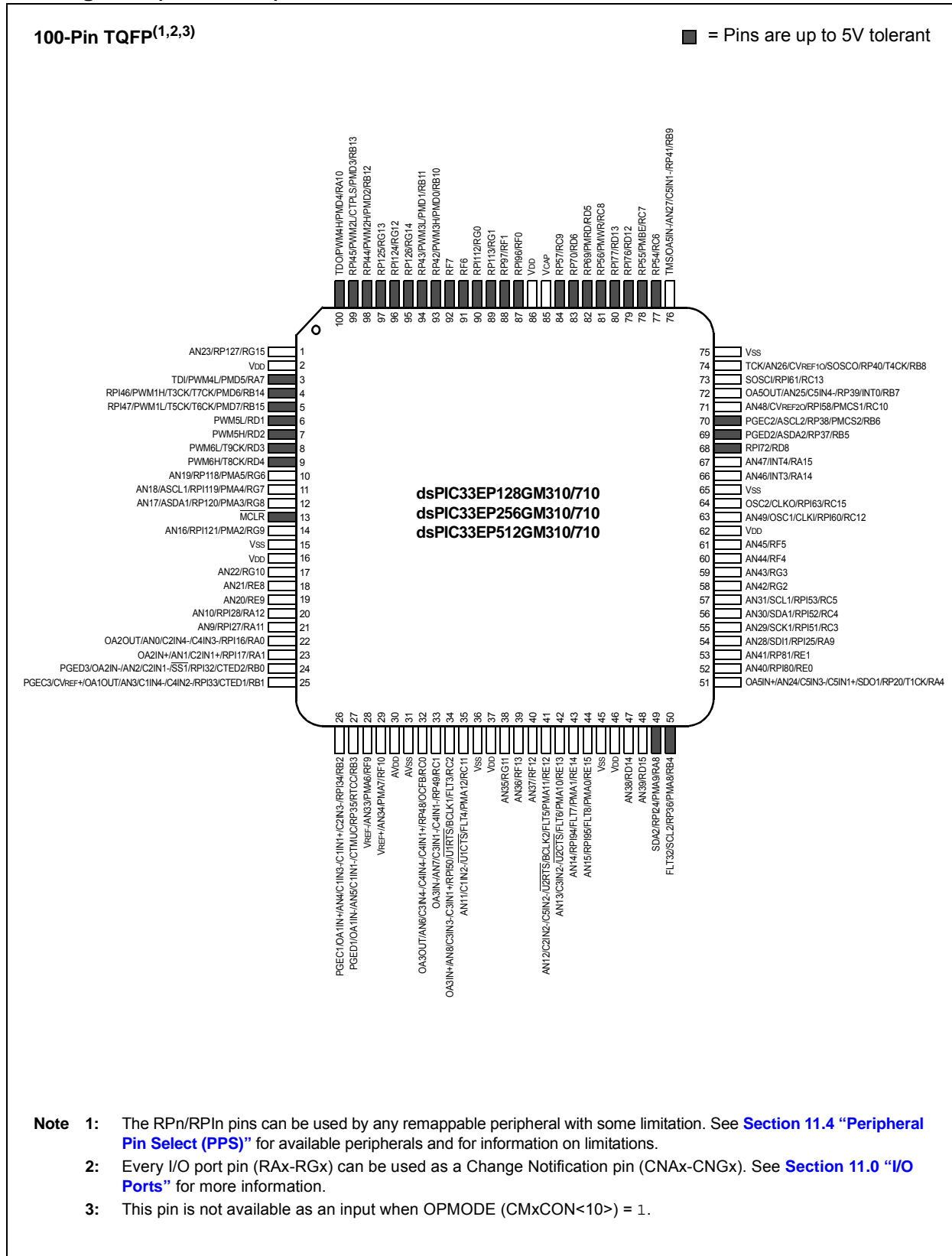

dsPIC33EPXXXGM3XX/6XX/7XX

Pin Diagrams (Continued)

121-Pin TFBGA⁽¹⁾

● = Pins are up to 5V tolerant

dsPIC33EP128GM310/710
dsPIC33EP256GM310/710
dsPIC33EP512GM310/710

	1	2	3	4	5	6	7	8	9	10	11
A	● RA10	● RB13	● RG13	● RB10	● RG0	● RF1	○ VDD	○ NC	● RD12	● RC6	○ RB9
B	○ NC	○ RG15	● RB12	● RB11	● RF7	● RF0	○ V _{CAP}	● RD5	● RC7	○ V _{SS}	○ RB8
C	● RB14	○ VDD	● RG12	● RG14	● RF6	○ NC	● RC9	● RC8	○ NC	○ RC13	○ RC10
D	● RD1	● RB15	● RA7	○ NC	○ NC	○ NC	● RD6	● RD13	○ RB7	○ NC	● RB6
E	● RD4	● RD3	○ RG6	● RD2	○ NC	● RG1	○ NC	○ RA15	● RD8	● RB5	○ RA14
F	● MCLR	○ RG8	○ RG9	○ RG7	○ V _{SS}	○ NC	○ NC	○ VDD	○ RC12	○ V _{SS}	○ RC15
G	○ RE8	○ RE9	○ RG10	○ NC	○ VDD	○ V _{SS}	○ V _{SS}	○ NC	○ RF5	○ RG3	○ RF4
H	○ RA12	○ RA11	○ NC	○ NC	○ NC	○ VDD	○ NC	○ RA9	○ RC3	○ RC5	○ RG2
J	○ RA0	○ RA1	○ RB3	○ AVDD	○ RC11	○ RG11	○ RE12	○ NC	○ NC	○ RE1	○ RC4
K	○ RB0	○ RB1	○ RF10	○ RC0	○ NC	○ RF12	○ RE14	○ VDD	○ RD15	○ RA4	○ RE0
L	○ RB2	○ RF9	○ AV _{SS}	○ RC1	○ RC2	○ RF13	○ RE13	○ RE15	○ RD14	● RA8	● RB4

Note 1: Refer to [Table 2](#) for full pin names.

dsPIC33EPXXXGM3XX/6XX/7XX

TABLE 2: PIN NAMES: dsPIC33EP128/256/512GM310/710 DEVICES^(1,2,3)

Pin #	Full Pin Name	Pin #	Full Pin Name
A1	TDO/PWM4H/PMD4/RA10	E8	AN47/INT4/RA15
A2	RPI45/PWM2L/CTPLS/PMD3/RB13	E9	RPI72/RD8
A3	RP125/RG13	E10	PGED2/ASDA2/RP37/RB5
A4	RP42/PWM3H/PMD0/RB10	E11	AN46/INT3/RA14
A5	RPI112/RG0	F1	MCLR
A6	RP97/RF1	F2	AN17/ASDA1/RP120/PMA3/RG8
A7	VDD	F3	AN16/RPI121/PMA2/RG9
A8	No Connect	F4	AN18/ASCL1/RPI119/PMA4/RG7
A9	RPI76/RD12	F5	Vss
A10	RP54/RC6	F6	No Connect
A11	TMS/OA5IN-/AN27/C5IN1-/RP41/RB9	F7	No Connect
B1	No Connect	F8	VDD
B2	AN23/RP127/RG15	F9	AN49/OSC1/CLKI/RPI60/RC12
B3	RPI44/PWM2H/PMD2/RB12	F10	Vss
B4	RP43/PWM3L/PMD1/RB11	F11	OSC2/CLKO/RPI63/RC15
B5	RF7	G1	AN21/RE8
B6	RPI96/RF0	G2	AN20/RE9
B7	VCAP	G3	AN22/RG10
B8	RP69/PMRD/RD5	G4	No Connect
B9	RP55/PMBE/RC7	G5	VDD
B10	Vss	G6	Vss
B11	TCK/AN26/CVREF10/SOSCO/RP40/T4CK/RB8	G7	Vss
C1	RPI46/PWM1H/T3CK/T7CK/PMD6/RB14	G8	No Connect
C2	VDD	G9	AN45/RF5
C3	RPI124/RG12	G10	AN43/RG3
C4	RP126/RG14	G11	AN44/RF4
C5	RF6	H1	AN10/RPI28/RA12
C6	No Connect	H2	AN9/RPI27/RA11
C7	RP57/RC9	H3	No Connect
C8	RP56/PMWR/RC8	H4	No Connect
C9	No Connect	H5	No Connect
C10	SOSCI/RPI61/RC13	H6	VDD
C11	AN48/CVREF20/RPI58/PMCS1/RC10	H7	No Connect
D1	PWM5L/RD1	H8	AN28/SD11/RPI25/RA9
D2	RPI47/PWM1L/T5CK/T6CK/PMD7/RB15	H9	AN29/SCK1/RPI51/RC3
D3	TDI/PWM4L/PMD5/RA7	H10	AN31/SCL1/RPI53/RC5
D4	No Connect	H11	AN42/RG2
D5	No Connect	J1	OA2OUT/AN0/C2IN4-/C4IN3-/RPI16/RA0
D6	No Connect	J2	OA2IN+/AN1/C2IN3-/C2IN1+/RPI17/RA1
D7	RP70/RD6	J3	PGED1/OA1IN-/AN5/C1IN1-/CTMUC/RP35/RTCC/RB3
D8	RPI77/RD13	J4	AVDD
D9	OA5OUT/AN25/C5IN4-/RP39/INT0/RB7	J5	AN11/C1IN2-/U1CTS/FLT4/PMA12/RC11
D10	No Connect	J6	AN35/RG11
D11	PGEC2/ASCL2/RP38/PMCS2/RB6	J7	AN12/C2IN2-/C5IN2-/U2RTS/BCLK2/FLT5/PMA11/RE12

- Note 1:** The RPN/RPIn pins can be used by any remappable peripheral with some limitation. See [Section 11.4 “Peripheral Pin Select \(PPS\)”](#) for available peripherals and for information on limitations.
- 2:** Every I/O port pin (RAX-RGx) can be used as a Change Notification pin (CNAX-CNGx). See [Section 11.0 “I/O Ports”](#) for more information.
- 3:** The availability of I²C™ interfaces varies by device. Selection (SDAx/SCLx or ASDAx/ASCLx) is made using the device Configuration bits, ALTI2C1 and ALTI2C2 (FPOR<5:4>). See [Section 30.0 “Special Features”](#) for more information.

dsPIC33EPXXXGM3XX/6XX/7XX

TABLE 2: PIN NAMES: dsPIC33EP128/256/512GM310/710 DEVICES^(1,2,3) (CONTINUED)

Pin #	Full Pin Name	Pin #	Full Pin Name
E1	PWM6H/T8CK/RD4	J8	No Connect
E2	PWM6L/T9CK/RD3	J9	No Connect
E3	AN19/RP118/PMA5/RG6	J10	AN41/RP81/RE1
E4	PWM5H/RD2	J11	AN30/SDA1/RPI52/RC4
E5	No Connect	K1	PGED3/OA2IN-/AN2/C2IN1-/SS1/RPI32/CTED2/RB0
E6	RP113/RG1	K2	PGEC3/CVREF+/OA1OUT/AN3/C1IN4-/C4IN2-/RPI33/CTED1/RB1
E7	No Connect	K3	VREF+/AN34/PMA7/RF10
K4	OA3OUT/AN6/C3IN4-/C4IN4-/C4IN1+/RP48/OCFB/RC0	L3	AVSS
K5	No Connect	L4	OA3IN-/AN7/C3IN1-/C4IN1-/RP49/RC1
K6	AN37/RF12	L5	OA3IN+/AN8/C3IN3-/C3IN1+/RPI50/U1RTS/BCLK1/FLT3/PMA13/RC2
K7	AN14/RPI94/FLT7/PMA1/RE14	L6	AN36/RF13
K8	VDD	L7	AN13/C3IN2-/U2CTS/FLT6/PMA10/RE13
K9	AN39/RD15	L8	AN15/RPI95/FLT8/PMA0/RE15
K10	OA5IN+/AN24/C5IN3-/C5IN1+/SDO1/RP20/T1CK/RA4	L9	AN38/RD14
K11	AN40/RPI80/RE0	L10	SDA2/RPI24/PMA9/RA8
L1	PGEC1/OA1IN+/AN4/C1IN3-/C1IN1+/C2IN3-/RPI34/RB2	L11	FLT32/SCL2/RP36/PMA8/RB4
L2	VREF-/AN33/PMA6/RF9		

- Note 1:** The RPN/RPIN pins can be used by any remappable peripheral with some limitation. See [Section 11.4 “Peripheral Pin Select \(PPS\)”](#) for available peripherals and for information on limitations.
- 2:** Every I/O port pin (RAX-RGX) can be used as a Change Notification pin (CNAX-CNGX). See [Section 11.0 “I/O Ports”](#) for more information.
- 3:** The availability of I²C™ interfaces varies by device. Selection (SDAX/SCLX or ASDAX/ASCLX) is made using the device Configuration bits, ALTI2C1 and ALTI2C2 (FPOR<5.4>). See [Section 30.0 “Special Features”](#) for more information.

Table of Contents

dsPIC33EPXXXGM3XX/6XX/7XX Product Family	2
1.0 Device Overview	15
2.0 Guidelines for Getting Started with 16-Bit Digital Signal Controllers	21
3.0 CPU	27
4.0 Memory Organization	37
5.0 Flash Program Memory	103
6.0 Resets	111
7.0 Interrupt Controller	115
8.0 Direct Memory Access (DMA)	129
9.0 Oscillator Configuration	143
10.0 Power-Saving Features	153
11.0 I/O Ports	163
12.0 Timer1	211
13.0 Timer2/3, Timer4/5, Timer6/7 and Timer8/9	213
14.0 Input Capture	219
15.0 Output Compare	223
16.0 High-Speed PWM Module	229
17.0 Quadrature Encoder Interface (QEI) Module	257
18.0 Serial Peripheral Interface (SPI)	273
19.0 Inter-Integrated Circuit™ (I ² C™)	281
20.0 Universal Asynchronous Receiver Transmitter (UART)	289
21.0 Controller Area Network (CAN) Module (dsPIC33EPXXXGM6XX/7XX Devices Only)	295
22.0 Charge Time Measurement Unit (CTMU)	321
23.0 10-Bit/12-Bit Analog-to-Digital Converter (ADC)	327
24.0 Data Converter Interface (DCI) Module	343
25.0 Peripheral Trigger Generator (PTG) Module	349
26.0 Op Amp/Comparator Module	365
27.0 Real-Time Clock and Calendar (RTCC)	383
28.0 Parallel Master Port (PMP)	395
29.0 Programmable Cyclic Redundancy Check (CRC) Generator	405
30.0 Special Features	411
31.0 Instruction Set Summary	419
32.0 Development Support	429
33.0 Electrical Characteristics	433
34.0 High-Temperature Electrical Characteristics	499
35.0 Packaging Information	507
Appendix A: Revision History	527
Index	529
The Microchip Web Site	537
Customer Change Notification Service	537
Customer Support	537
Product Identification System	539

TO OUR VALUED CUSTOMERS

It is our intention to provide our valued customers with the best documentation possible to ensure successful use of your Microchip products. To this end, we will continue to improve our publications to better suit your needs. Our publications will be refined and enhanced as new volumes and updates are introduced.

If you have any questions or comments regarding this publication, please contact the Marketing Communications Department via E-mail at docerrors@microchip.com. We welcome your feedback.

Most Current Data Sheet

To obtain the most up-to-date version of this data sheet, please register at our Worldwide Web site at:

<http://www.microchip.com>

You can determine the version of a data sheet by examining its literature number found on the bottom outside corner of any page. The last character of the literature number is the version number, (e.g., DS30000000A is version A of document DS30000000).

Errata

An errata sheet, describing minor operational differences from the data sheet and recommended workarounds, may exist for current devices. As device/documentation issues become known to us, we will publish an errata sheet. The errata will specify the revision of silicon and revision of document to which it applies.

To determine if an errata sheet exists for a particular device, please check with one of the following:

- Microchip's Worldwide Web site; <http://www.microchip.com>
- Your local Microchip sales office (see last page)

When contacting a sales office, please specify which device, revision of silicon and data sheet (include literature number) you are using.

Customer Notification System

Register on our web site at www.microchip.com to receive the most current information on all of our products.

Referenced Sources

This device data sheet is based on the following individual chapters of the *dsPIC33/PIC24 Family Reference Manual*, which are available from the Microchip web site (www.microchip.com). These documents should be considered as the general reference for the operation of a particular module or device feature.

- **“Introduction”** (DS70573)
- **“CPU”** (DS70359)
- **“Data Memory”** (DS70595)
- **“Program Memory”** (DS70613)
- **“Flash Programming”** (DS70609)
- **“Interrupts”** (DS70000600)
- **“Oscillator”** (DS70580)
- **“Reset”** (DS70602)
- **“Watchdog Timer and Power-Saving Modes”** (DS70615)
- **“I/O Ports”** (DS70000598)
- **“Timers”** (DS70362)
- **“Input Capture”** (DS70000352)
- **“Output Compare”** (DS70005157)
- **“High-Speed PWM”** (DS70645)
- **“Quadrature Encoder Interface (QEI)”** (DS70601)
- **“Analog-to-Digital Converter (ADC)”** (DS70621)
- **“Universal Asynchronous Receiver Transmitter (UART)”** (DS70000582)
- **“Serial Peripheral Interface (SPI)”** (DS70005185)
- **“Inter-Integrated Circuit™ (I²C™)”** (DS70000195)
- **“Data Converter Interface (DCI) Module”** (DS70356)
- **“Enhanced Controller Area Network (ECAN™)”** (DS70353)
- **“Direct Memory Access (DMA)”** (DS70348)
- **“Programming and Diagnostics”** (DS70608)
- **“Op Amp/Comparator”** (DS70000357)
- **“32-Bit Programmable Cyclic Redundancy Check (CRC)”** (DS70346)
- **“Parallel Master Port (PMP)”** (DS70576)
- **“Device Configuration”** (DS70000618)
- **“Peripheral Trigger Generator (PTG)”** (DS70669)
- **“Charge Time Measurement Unit (CTMU)”** (DS70661)

dsPIC33EPXXGM3XX/6XX/7XX

NOTES:

1.0 DEVICE OVERVIEW

Note 1: This data sheet summarizes the features of the dsPIC33EPXXXGM3XX/6XX/7XX family of devices. It is not intended to be a comprehensive resource. To complement the information in this data sheet, refer to the related section of the “dsPIC33/PIC24 Family Reference Manual”, which is available from the Microchip web site (www.microchip.com)

2: Some registers and associated bits described in this section may not be available on all devices. Refer to **Section 4.0 “Memory Organization”** in this data sheet for device-specific register and bit information.

This document contains device-specific information for the dsPIC33EPXXXGM3XX/6XX/7XX Digital Signal Controller (DSC) devices.

dsPIC33EPXXXGM3XX/6XX/7XX devices contain extensive Digital Signal Processor (DSP) functionality with a high-performance, 16-bit MCU architecture.

Figure 1-1 shows a general block diagram of the core and peripheral modules. Table 1-1 lists the functions of the various pins shown in the pinout diagrams.

FIGURE 1-1: dsPIC33EPXXXGM3XX/6XX/7XX BLOCK DIAGRAM

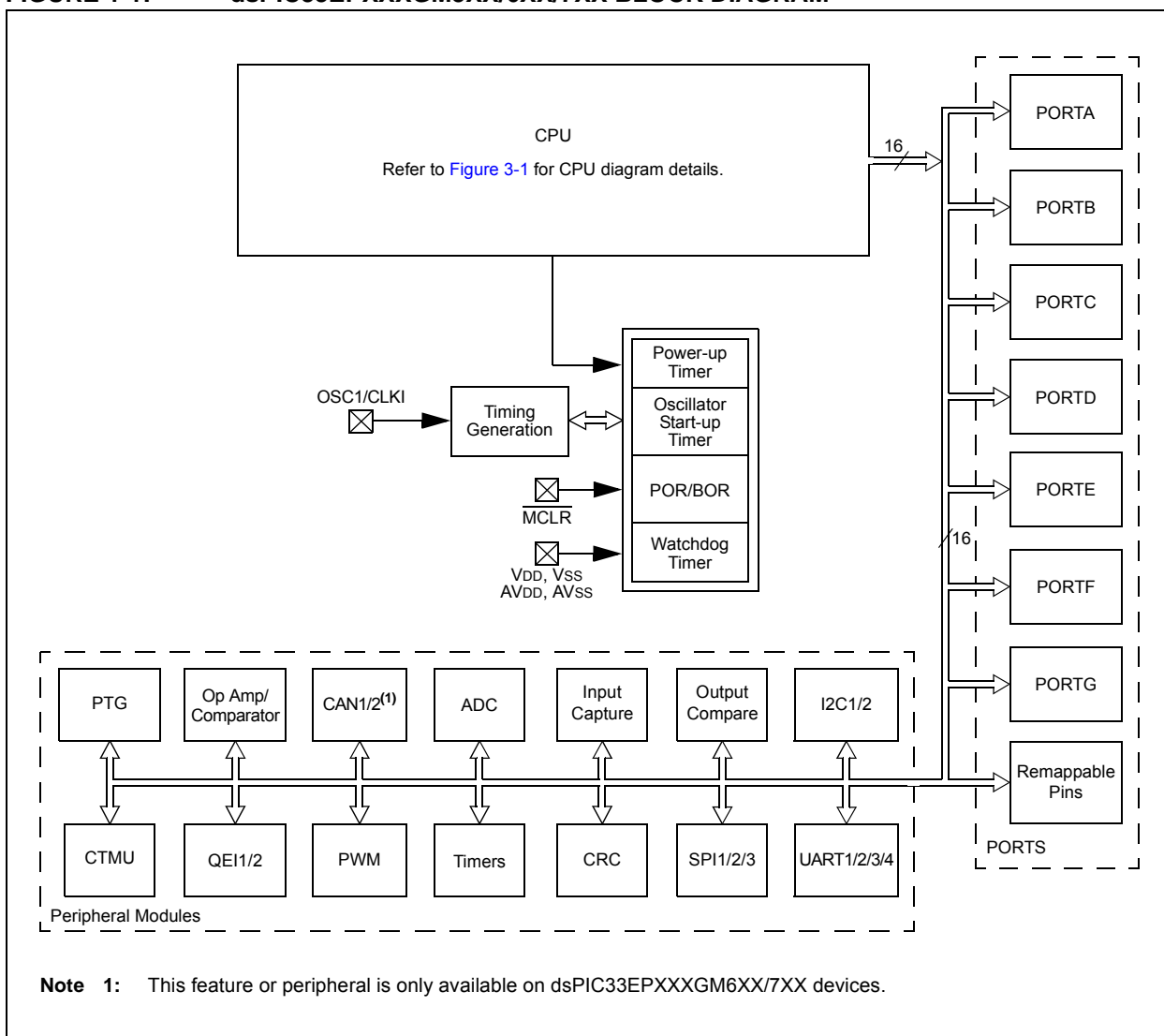

dsPIC33EPXXXGM3XX/6XX/7XX

TABLE 1-1: PINOUT I/O DESCRIPTIONS

Pin Name	Pin Type	Buffer Type	PPS	Description
AN0-AN49	I	Analog	No	Analog Input Channels 0-49.
CLKI	I	ST/ CMOS	No	External clock source input. Always associated with OSC1 pin function.
CLKO	O	—	No	Oscillator crystal output. Connects to crystal or resonator in Crystal Oscillator mode. Optionally functions as CLKO in RC and EC modes. Always associated with OSC2 pin function.
OSC1	I	ST/ CMOS	No	Oscillator crystal input. ST buffer when configured in RC mode; CMOS otherwise.
OSC2	I/O	—	No	Oscillator crystal output. Connects to crystal or resonator in Crystal Oscillator mode. Optionally functions as CLKO in RC and EC modes.
SOSCI	I	ST/ CMOS	No	32.768 kHz low-power oscillator crystal input; CMOS otherwise.
SOSCO	O	—	No	32.768 kHz low-power oscillator crystal output.
IC1-IC8	I	ST	Yes	Input Capture Inputs 1 through 8.
OCFA	I	ST	Yes	Output Compare Fault A input (for compare channels).
OCFB	I	ST	No	Output Compare Fault B input (for compare channels).
OC1-OC8	O	—	Yes	Output Compare 1 through 8.
INT0	I	ST	No	External Interrupt 0.
INT1	I	ST	Yes	External Interrupt 1.
INT2	I	ST	Yes	External Interrupt 2.
INT3	I	ST	No	External Interrupt 3.
INT4	I	ST	No	External Interrupt 4.
RA0-RA4, RA7-RA12, RA14-RA15	I/O	ST	Yes	PORTA is a bidirectional I/O port.
RB0-RB15	I/O	ST	Yes	PORTB is a bidirectional I/O port.
RC0-RC13, RC15	I/O	ST	Yes	PORTC is a bidirectional I/O port.
RD1-RD6, RD8, RD12-RD15	I/O	ST	Yes	PORTD is a bidirectional I/O port.
RE0-RE1, RE8-RE9, RE12-RE15	I/O	ST	Yes	PORTE is a bidirectional I/O port.
RF0-RF1, RF4-RF7, RF9-RF10, RF12-RF13	I/O	ST	No	PORTF is a bidirectional I/O port.
RG0-RG3, RG6-RG15	I/O	ST	Yes	PORTG is a bidirectional I/O port.
T1CK	I	ST	No	Timer1 external clock input.
T2CK	I	ST	Yes	Timer2 external clock input.
T3CK	I	ST	No	Timer3 external clock input.
T4CK	I	ST	No	Timer4 external clock input.
T5CK	I	ST	No	Timer5 external clock input.
T6CK	I	ST	No	Timer6 external clock input.
T7CK	I	ST	No	Timer7 external clock input.
T8CK	I	ST	No	Timer8 external clock input.
T9CK	I	ST	No	Timer9 external clock input.

Legend: CMOS = CMOS compatible input or output Analog = Analog input P = Power
 ST = Schmitt Trigger input with CMOS levels O = Output I = Input
 PPS = Peripheral Pin Select TTL = TTL input buffer

Note 1: This pin is not available on all devices. For more information, see the “Pin Diagrams” section for pin availability.

2: AVDD must be connected at all times.

dsPIC33EPXXXGM3XX/6XX/7XX

TABLE 1-1: PINOUT I/O DESCRIPTIONS (CONTINUED)

Pin Name	Pin Type	Buffer Type	PPS	Description
U1CTS	I	ST	Yes	UART1 Clear-to-Send.
U1RTS	O	—	Yes	UART1 Ready-to-Send.
U1RX	I	ST	Yes	UART1 receive.
U1TX	O	—	Yes	UART1 transmit.
U2CTS	I	ST	Yes	UART2 Clear-to-Send.
U2RTS	O	—	Yes	UART2 Ready-to-Send.
U2RX	I	ST	Yes	UART2 receive.
U2TX	O	—	Yes	UART2 transmit.
U3CTS	I	ST	Yes	UART3 Clear-to-Send.
U3RTS	O	—	Yes	UART3 Ready-to-Send.
U3RX	I	ST	Yes	UART3 receive.
U3TX	O	—	Yes	UART3 transmit.
U4CTS	I	ST	Yes	UART4 Clear-to-Send.
U4RTS	O	—	Yes	UART4 Ready-to-Send.
U4RX	I	ST	Yes	UART4 receive.
U4TX	O	—	Yes	UART4 transmit.
SCK1	I/O	ST	No	Synchronous serial clock input/output for SPI1.
SDI1	I	ST	No	SPI1 data in.
SDO1	O	—	No	SPI1 data out.
SS1	I/O	ST	No	SPI1 slave synchronization or frame pulse I/O.
SCK2	I/O	ST	Yes	Synchronous serial clock input/output for SPI2.
SDI2	I	ST	Yes	SPI2 data in.
SDO2	O	—	Yes	SPI2 data out.
SS2	I/O	ST	Yes	SPI2 slave synchronization or frame pulse I/O.
SCK3	I/O	ST	Yes	Synchronous serial clock input/output for SPI3.
SDI3	I	ST	Yes	SPI3 data in.
SDO3	O	—	Yes	SPI3 data out.
SS3	I/O	ST	Yes	SPI3 slave synchronization or frame pulse I/O.
SCL1	I/O	ST	No	Synchronous serial clock input/output for I2C1.
SDA1	I/O	ST	No	Synchronous serial data input/output for I2C1.
ASCL1	I/O	ST	No	Alternate synchronous serial clock input/output for I2C1.
ASDA1	I/O	ST	No	Alternate synchronous serial data input/output for I2C1.
SCL2	I/O	ST	No	Synchronous serial clock input/output for I2C2.
SDA2	I/O	ST	No	Synchronous serial data input/output for I2C2.
ASCL2	I/O	ST	No	Alternate synchronous serial clock input/output for I2C2.
ASDA2	I/O	ST	No	Alternate synchronous serial data input/output for I2C2.
TMS	I	ST	No	JTAG Test mode select pin.
TCK	I	ST	No	JTAG test clock input pin.
TDI	I	ST	No	JTAG test data input pin.
TDO	O	—	No	JTAG test data output pin.

Legend: CMOS = CMOS compatible input or output Analog = Analog input P = Power
 ST = Schmitt Trigger input with CMOS levels O = Output I = Input
 PPS = Peripheral Pin Select TTL = TTL input buffer

- Note 1:** This pin is not available on all devices. For more information, see the “[Pin Diagrams](#)” section for pin availability.
- 2:** AVDD must be connected at all times.

dsPIC33EPXXXGM3XX/6XX/7XX

TABLE 1-1: PINOUT I/O DESCRIPTIONS (CONTINUED)

Pin Name	Pin Type	Buffer Type	PPS	Description
INDX1 ⁽¹⁾	I	ST	Yes	Quadrature Encoder Index1 pulse input.
HOME1 ⁽¹⁾	I	ST	Yes	Quadrature Encoder Home1 pulse input.
QEA1 ⁽¹⁾	I	ST	Yes	Quadrature Encoder Phase A input in QE11 mode. Auxiliary timer external clock input in Timer mode.
QEB1 ⁽¹⁾	I	ST	Yes	Quadrature Encoder Phase A input in QE11 mode. Auxiliary timer external gate input in Timer mode.
CNTCMP1 ⁽¹⁾	O	—	Yes	Quadrature Encoder Compare Output 1.
INDX2 ⁽¹⁾	I	ST	Yes	Quadrature Encoder Index2 Pulse input.
HOME2 ⁽¹⁾	I	ST	Yes	Quadrature Encoder Home2 Pulse input.
QEA2 ⁽¹⁾	I	ST	Yes	Quadrature Encoder Phase A input in QE12 mode. Auxiliary timer external clock input in Timer mode.
QEB2 ⁽¹⁾	I	ST	Yes	Quadrature Encoder Phase B input in QE12 mode. Auxiliary timer external gate input in Timer mode.
CNTCMP2 ⁽¹⁾	O	—	Yes	Quadrature Encoder Compare Output 2.
COFS	I/O	ST	Yes	Data Converter Interface frame synchronization pin.
CCLK	I/O	ST	Yes	Data Converter Interface serial clock input/output pin.
CSDI	I	ST	Yes	Data Converter Interface serial data input pin.
CSDO	O	—	Yes	Data Converter Interface serial data output pin.
C1RX	I	ST	Yes	CAN1 bus receive pin.
C1TX	O	—	Yes	CAN1 bus transmit pin
C2RX	I	ST	Yes	CAN2 bus receive pin.
C2TX	O	—	Yes	CAN2 bus transmit pin
RTCC	O	—	No	Real-Time Clock and Calendar alarm output.
CVREF	O	Analog	No	Comparator Voltage Reference output.
C1IN1+, C1IN2-, C1IN1-, C1IN3- C1OUT	I O	Analog —	No Yes	Comparator 1 inputs. Comparator 1 output.
C2IN1+, C2IN2-, C2IN1-, C2IN3- C2OUT	I O	Analog —	No Yes	Comparator 2 inputs. Comparator 2 output.
C3IN1+, C3IN2-, C2IN1-, C3IN3- C3OUT	I O	Analog —	No Yes	Comparator 3 inputs. Comparator 3 output.
C4IN1+, C4IN2-, C4IN1-, C4IN3- C4OUT	I O	Analog —	No Yes	Comparator 4 inputs. Comparator 4 output.
C5IN1-, C5IN2-, C5IN3-, C5IN4-, C5IN1+ C5OUT	I O	Analog —	No Yes	Comparator 5 inputs. Comparator 5 output.

Legend: CMOS = CMOS compatible input or output Analog = Analog input P = Power
 ST = Schmitt Trigger input with CMOS levels O = Output I = Input
 PPS = Peripheral Pin Select TTL = TTL input buffer

- Note 1:** This pin is not available on all devices. For more information, see the “Pin Diagrams” section for pin availability.
- 2:** AVDD must be connected at all times.

TABLE 1-1: PINOUT I/O DESCRIPTIONS (CONTINUED)

Pin Name	Pin Type	Buffer Type	PPS	Description
PMA0	I/O	TTL/ST	No	Parallel Master Port Address Bit 0 input (Buffered Slave modes) and output (Master modes).
PMA1	I/O	TTL/ST	No	Parallel Master Port Address Bit 1 input (Buffered Slave modes) and output (Master modes).
PMA2-PMA13	O	—	No	Parallel Master Port Address Bits 2-13 (Demultiplexed Master modes).
PMBE	O	—	No	Parallel Master Port Byte Enable strobe.
PMCS1, PMCS2	O	—	No	Parallel Master Port Chip Select 1 and 2 strobe.
PMD0-PMD7	I/O	TTL/ST	No	Parallel Master Port Data (Demultiplexed Master mode) or Address/Data (Multiplexed Master modes).
PMRD	O	—	No	Parallel Master Port Read strobe.
PMWR	O	—	No	Parallel Master Port Write strobe.
FLT1-FLT2 ⁽¹⁾	I	ST	Yes	PWMx Fault Inputs 1 through 2.
FLT3-FLT8 ⁽¹⁾	I	ST	No	PWMx Fault Inputs 3 through 8
FLT32	I	ST	No	PWMx Fault Input 32
DTCMP1-DTCMP6 ⁽¹⁾	I	ST	Yes	PWMx Dead-Time Compensation Inputs 1 through 6.
PWM1L-PWM6L ⁽¹⁾	O	—	No	PWMx Low Outputs 1 through 7.
PWM1H-PWM6H ⁽¹⁾	O	—	No	PWMx High Outputs 1 through 7.
SYNC1 ⁽¹⁾ , SYNC12 ⁽¹⁾	I	ST	Yes	PWMx Synchronization Input 1.
SYNCO1, SYNCO2 ⁽¹⁾	O	—	Yes	PWMx Synchronization Outputs 1 and 2.
PGED1	I/O	ST	No	Data I/O pin for Programming/Debugging Communication Channel 1.
PGEC1	I	ST	No	Clock input pin for Programming/Debugging Communication Channel 1.
PGED2	I/O	ST	No	Data I/O pin for Programming/Debugging Communication Channel 2.
PGEC2	I	ST	No	Clock input pin for Programming/Debugging Communication Channel 2.
PGED3	I/O	ST	No	Data I/O pin for Programming/Debugging Communication Channel 3.
PGEC3	I	ST	No	Clock input pin for Programming/Debugging Communication Channel 3.
MCLR	I/P	ST	No	Master Clear (Reset) input. This pin is an active-low Reset to the device.
AVDD ⁽²⁾	P	P	No	Positive supply for analog modules. This pin must be connected at all times.
AVSS	P	P	No	Ground reference for analog modules.
VDD	P	—	No	Positive supply for peripheral logic and I/O pins.
VCAP	P	—	No	CPU logic filter capacitor connection.
VSS	P	—	No	Ground reference for logic and I/O pins.
VREF+	I	Analog	No	Analog voltage reference (high) input.
VREF-	I	Analog	No	Analog voltage reference (low) input.

Legend: CMOS = CMOS compatible input or output Analog = Analog input P = Power
 ST = Schmitt Trigger input with CMOS levels O = Output I = Input
 PPS = Peripheral Pin Select TTL = TTL input buffer

Note 1: This pin is not available on all devices. For more information, see the “Pin Diagrams” section for pin availability.

2: AVDD must be connected at all times.

dsPIC33EPXXGM3XX/6XX/7XX

NOTES:

2.0 GUIDELINES FOR GETTING STARTED WITH 16-BIT DIGITAL SIGNAL CONTROLLERS

- Note 1:** This data sheet summarizes the features of the dsPIC33EPXXXGM3XX/6XX/7XX family of devices. It is not intended to be a comprehensive reference source. To complement the information in this data sheet, refer to the related section of the “dsPIC33/PIC24 Family Reference Manual”, which is available from the Microchip web site (www.microchip.com)
- 2:** Some registers and associated bits described in this section may not be available on all devices. Refer to [Section 4.0 “Memory Organization”](#) in this data sheet for device-specific register and bit information.

2.1 Basic Connection Requirements

Getting started with the dsPIC33EPXXXGM3XX/6XX/7XX family requires attention to a minimal set of device pin connections before proceeding with development. The following is a list of pin names, which must always be connected:

- All VDD and VSS pins (see [Section 2.2 “Decoupling Capacitors”](#))
- All AVDD and AVSS pins (regardless if ADC module is not used) (see [Section 2.2 “Decoupling Capacitors”](#))
- VCAP (see [Section 2.3 “CPU Logic Filter Capacitor Connection \(VCAP\)”](#))
- MCLR pin (see [Section 2.4 “Master Clear \(MCLR\) Pin”](#))
- PGECx/PGEDx pins used for In-Circuit Serial Programming™ (ICSP™) and debugging purposes (see [Section 2.5 “ICSP Pins”](#))
- OSC1 and OSC2 pins when external oscillator source is used (see [Section 2.6 “External Oscillator Pins”](#))

Additionally, the following pins may be required:

- VREF+/VREF- pins are used when external voltage reference for ADC module is implemented

Note: The AVDD and AVSS pins must be connected independent of the ADC voltage reference source.

2.2 Decoupling Capacitors

The use of decoupling capacitors on every pair of power supply pins, such as VDD, VSS, AVDD and AVSS is required.

Consider the following criteria when using decoupling capacitors:

- **Value and type of capacitor:** Recommendation of 0.1 μF (100 nF), 10-20V. This capacitor should be a low-ESR and have resonance frequency in the range of 20 MHz and higher. It is recommended to use ceramic capacitors.
- **Placement on the printed circuit board:** The decoupling capacitors should be placed as close to the pins as possible. It is recommended to place the capacitors on the same side of the board as the device. If space is constricted, the capacitor can be placed on another layer on the PCB using a via; however, ensure that the trace length from the pin to the capacitor is within one-quarter inch (6 mm) in length.
- **Handling high-frequency noise:** If the board is experiencing high-frequency noise, above tens of MHz, add a second ceramic-type capacitor in parallel to the above described decoupling capacitor. The value of the second capacitor can be in the range of 0.01 μF to 0.001 μF . Place this second capacitor next to the primary decoupling capacitor. In high-speed circuit designs, consider implementing a decade pair of capacitances as close to the power and ground pins as possible. For example, 0.1 μF in parallel with 0.001 μF .
- **Maximizing performance:** On the board layout from the power supply circuit, run the power and return traces to the decoupling capacitors first, and then to the device pins. This ensures that the decoupling capacitors are first in the power chain. Equally important is to keep the trace length between the capacitor and the power pins to a minimum, thereby reducing PCB track inductance.

dsPIC33EPXXXGM3XX/6XX/7XX

FIGURE 2-1: RECOMMENDED MINIMUM CONNECTION

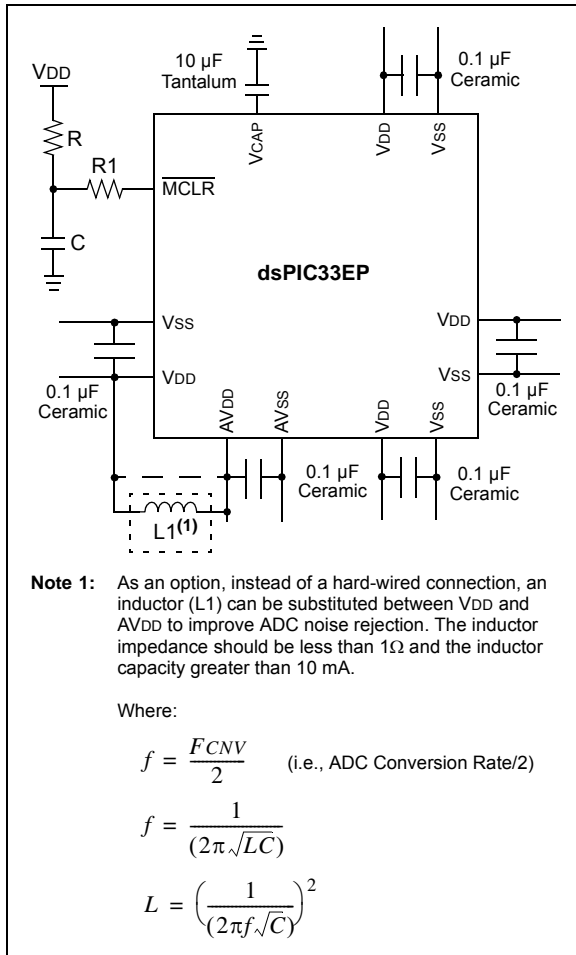

2.2.1 TANK CAPACITORS

On boards with power traces running longer than six inches in length, it is suggested to use a tank capacitor for integrated circuits including DSCs to supply a local power source. The value of the tank capacitor should be determined based on the trace resistance that connects the power supply source to the device, and the maximum current drawn by the device in the application. In other words, select the tank capacitor so that it meets the acceptable voltage sag at the device. Typical values range from 4.7 µF to 47 µF.

2.3 CPU Logic Filter Capacitor Connection (VCAP)

A low-ESR (< 1 Ohms) capacitor is required on the VCAP pin, which is used to stabilize the voltage regulator output voltage. The VCAP pin must not be connected to VDD, and must have a capacitor greater than 4.7 µF (10 µF is recommended), 16V connected to ground. The type can be ceramic or tantalum. See [Section 33.0 “Electrical Characteristics”](#) for additional information.

The placement of this capacitor should be close to the VCAP pin. It is recommended that the trace length not exceeds one-quarter inch (6 mm). See [Section 30.3 “On-Chip Voltage Regulator”](#) for details.

2.4 Master Clear (MCLR) Pin

The MCLR pin provides two specific device functions:

- Device Reset
- Device Programming and Debugging.

During device programming and debugging, the resistance and capacitance that can be added to the pin must be considered. Device programmers and debuggers drive the MCLR pin. Consequently, specific voltage levels (VIH and VIL) and fast signal transitions must not be adversely affected. Therefore, specific values of R and C will need to be adjusted based on the application and PCB requirements.

For example, as shown in [Figure 2-2](#), it is recommended that the capacitor, C, be isolated from the MCLR pin during programming and debugging operations.

Place the components as shown in [Figure 2-2](#) within one-quarter inch (6 mm) from the MCLR pin.

FIGURE 2-2: EXAMPLE OF MCLR PIN CONNECTIONS

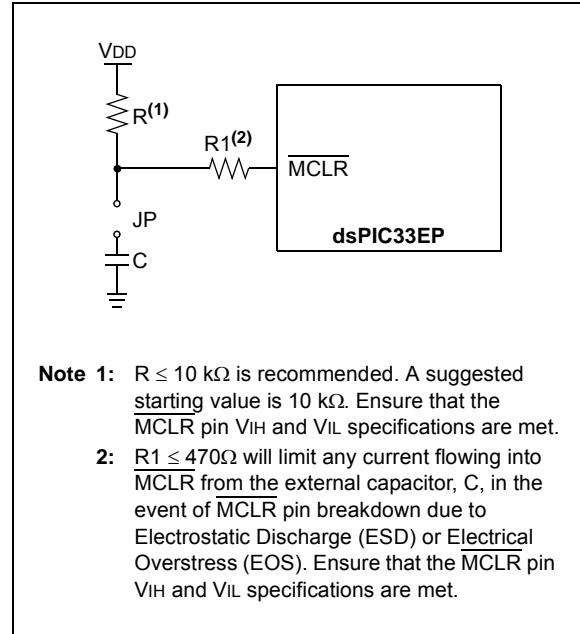

2.5 ICSP Pins

The PGECx and PGEDx pins are used for ICSP and debugging purposes. It is recommended to keep the trace length between the ICSP connector and the ICSP pins on the device as short as possible. If the ICSP connector is expected to experience an ESD event, a series resistor is recommended, with the value in the range of a few tens of Ohms, not to exceed 100 Ohms.

Pull-up resistors, series diodes and capacitors on the PGECx and PGEDx pins are not recommended as they will interfere with the programmer/debugger communications to the device. If such discrete components are an application requirement, they should be removed from the circuit during programming and debugging. Alternatively, refer to the AC/DC characteristics and timing requirements information in the respective device Flash programming specification for information on capacitive loading limits and pin Voltage Input High (VIH) and Voltage Input Low (VIL) requirements.

Ensure that the “Communication Channel Select” (i.e., PGECx/PGEDx pins) programmed into the device matches the physical connections for the ICSP to MPLAB® PICKit™ 3, MPLAB ICD 3, or MPLAB REAL ICE™.

For more information on MPLAB ICD 2, ICD 3 and REAL ICE connection requirements, refer to the following documents that are available on the Microchip web site:

- “Using MPLAB® ICD 3” (poster) DS51765
- “MPLAB® ICD 3 Design Advisory” DS51764
- “MPLAB® REAL ICE™ In-Circuit Emulator User’s Guide” DS51616
- “Using MPLAB® REAL ICE™ In-Circuit Emulator” (poster) DS51749

2.6 External Oscillator Pins

Many DSCs have options for at least two oscillators: a high-frequency primary oscillator and a low-frequency secondary oscillator. For details, see [Section 9.0 “Oscillator Configuration”](#) for details.

The oscillator circuit should be placed on the same side of the board as the device. Also, place the oscillator circuit close to the respective oscillator pins, not exceeding one-half inch (12 mm) distance between them. The load capacitors should be placed next to the oscillator itself, on the same side of the board. Use a grounded copper pour around the oscillator circuit to isolate them from surrounding circuits. The grounded copper pour should be routed directly to the MCU ground. Do not run any signal traces or power traces inside the ground pour. Also, if using a two-sided board, avoid any traces on the other side of the board where the crystal is placed. A suggested layout is shown in [Figure 2-3](#).

FIGURE 2-3: SUGGESTED PLACEMENT OF THE OSCILLATOR CIRCUIT

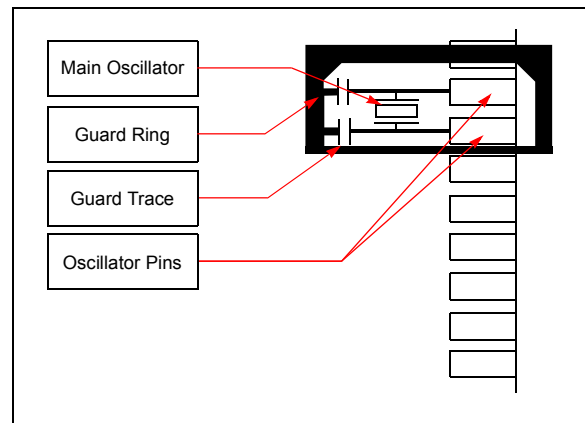

dsPIC33EPXXXGM3XX/6XX/7XX

2.7 Oscillator Value Conditions on Device Start-up

If the PLL of the target device is enabled and configured for the device start-up oscillator, the maximum oscillator source frequency must be limited to $5 \text{ MHz} < F_{IN} < 13.6 \text{ MHz}$ to comply with device PLL start-up conditions. This means that if the external oscillator frequency is outside this range, the application must start up in the FRC mode first. The default PLL settings after a POR with an oscillator frequency outside this range will violate the device operating speed.

Once the device powers up, the application firmware can initialize the PLL SFRs, CLKDIV and PLLDBF to a suitable value, and then perform a clock switch to the Oscillator + PLL clock source. Note that clock switching must be enabled in the device Configuration Word.

2.8 Unused I/Os

Unused I/O pins should be configured as outputs and driven to a logic low state.

Alternatively, connect a 1k to 10k resistor between V_{SS} and unused pins, and drive the output to logic low.

2.9 Application Examples

- Induction heating
- Uninterruptable Power Supplies (UPS)
- DC/AC inverters
- Compressor motor control
- Washing machine 3-phase motor control
- BLDC motor control
- Automotive HVAC, cooling fans, fuel pumps
- Stepper motor control
- Audio and fluid sensor monitoring
- Camera lens focus and stability control
- Speech (playback, hands-free kits, answering machines, VoIP)
- Consumer audio
- Industrial and building control (security systems and access control)
- Barcode reading
- Networking: LAN switches, gateways
- Data storage device management
- Smart cards and smart card readers
- Dual motor control

Examples of typical application connections are shown in [Figure 2-4](#) through [Figure 2-8](#).

FIGURE 2-4: BOOST CONVERTER IMPLEMENTATION

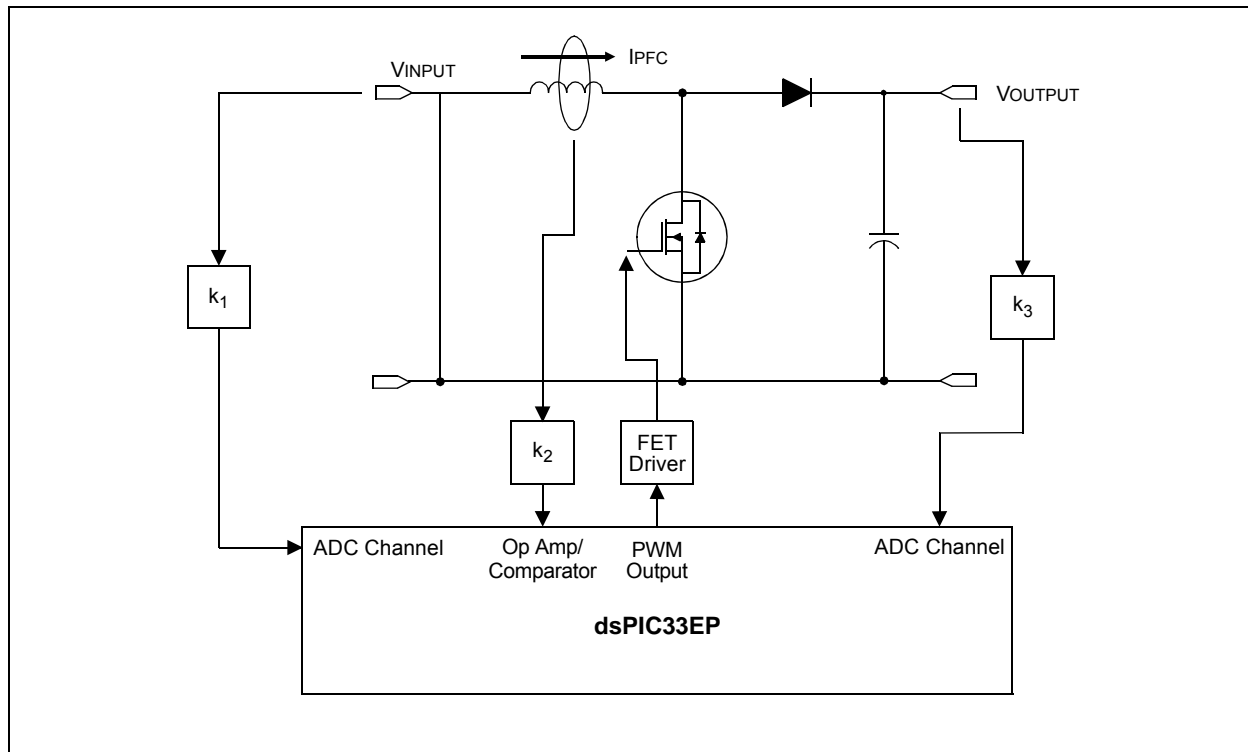

FIGURE 2-5: SINGLE-PHASE SYNCHRONOUS BUCK CONVERTER

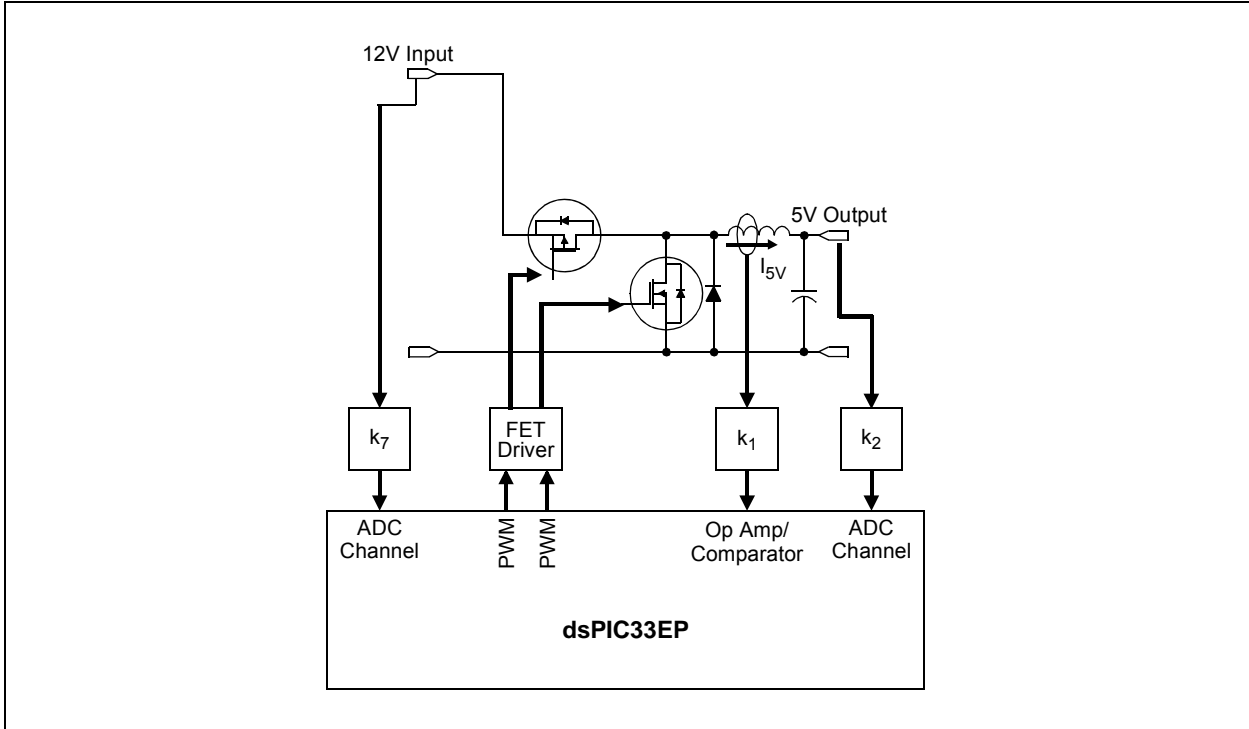
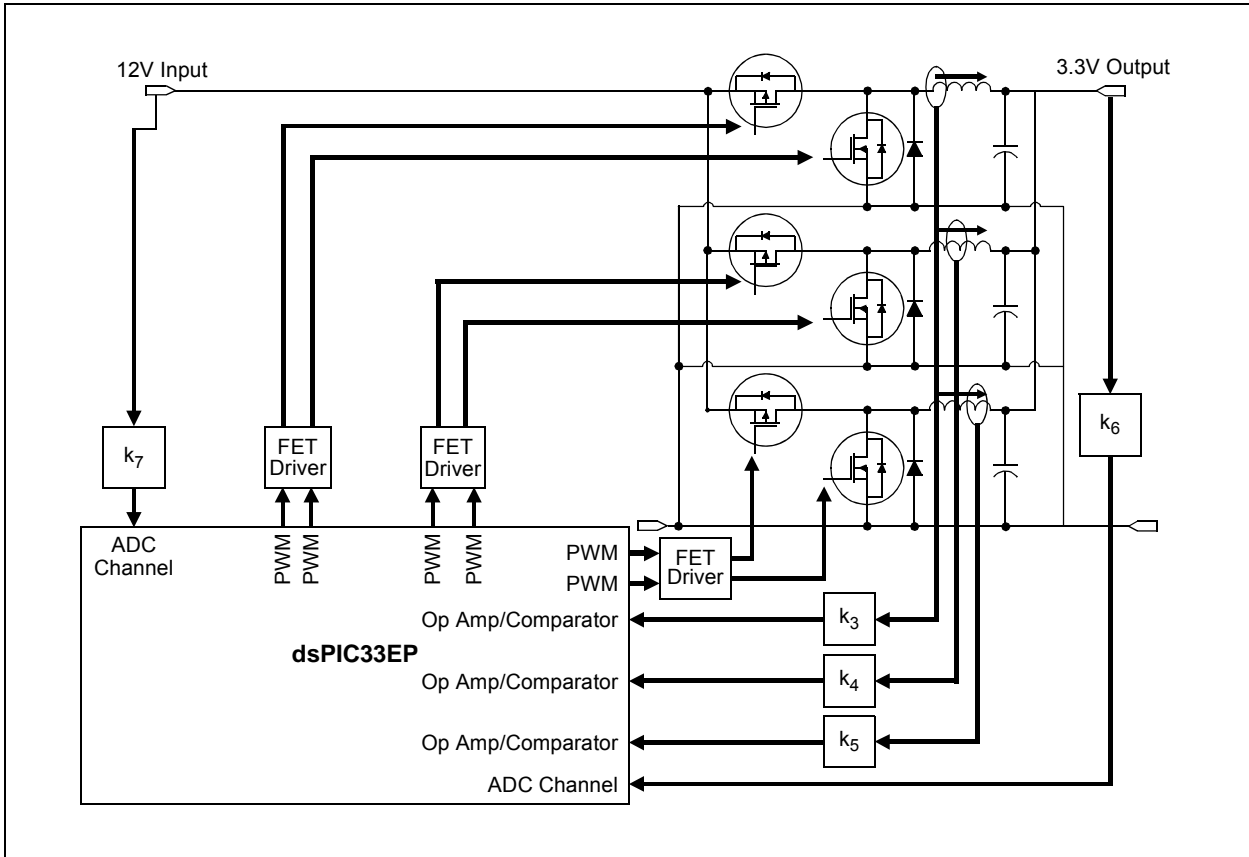

FIGURE 2-6: MULTIPHASE SYNCHRONOUS BUCK CONVERTER



dsPIC33EPXXXGM3XX/6XX/7XX

FIGURE 2-7: INTERLEAVED PFC

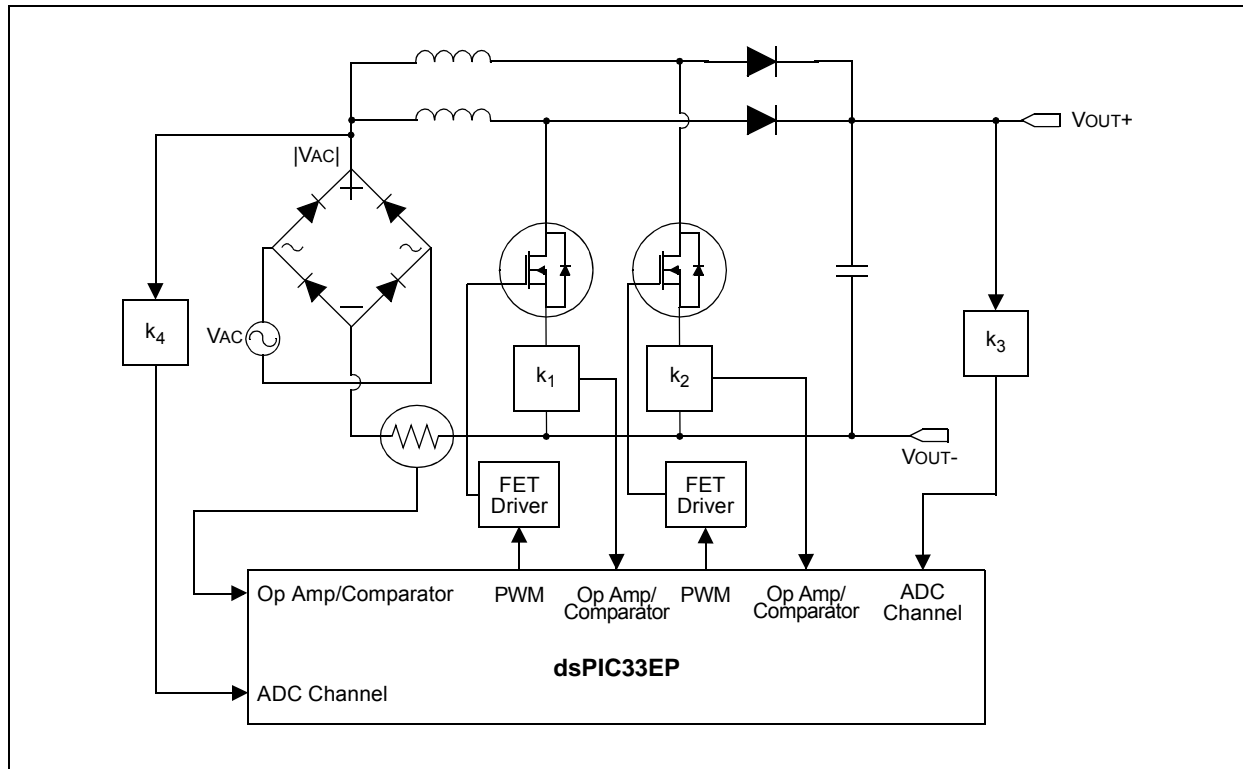
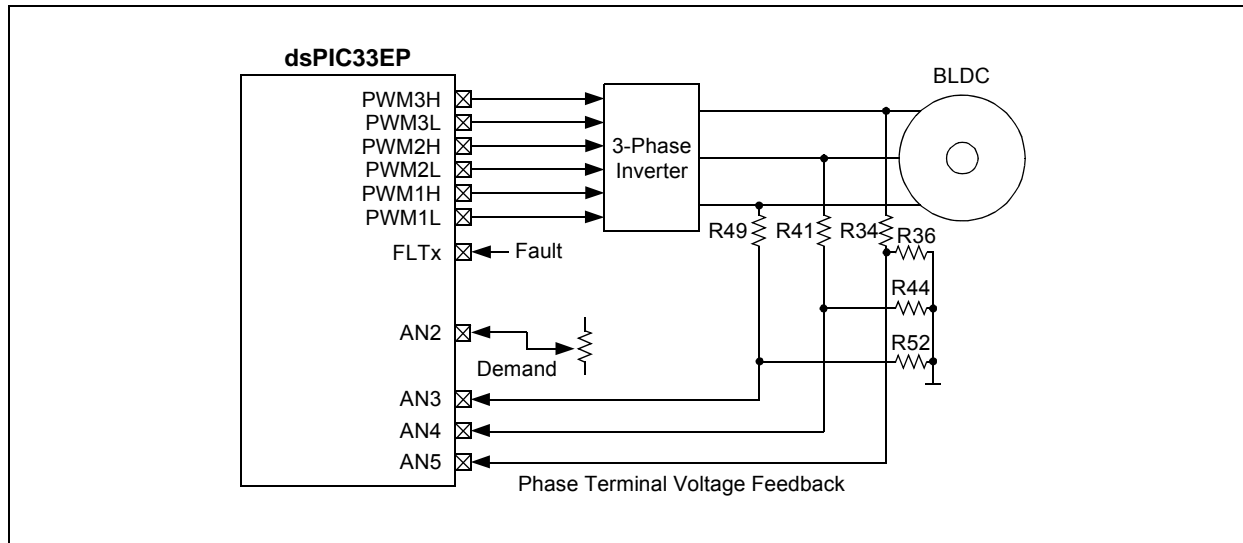

FIGURE 2-8: BEMF VOLTAGE MEASURED USING THE ADC MODULE



3.0 CPU

Note 1: This data sheet summarizes the features of the dsPIC33EPXXXGM3XX/6XX/7XX family of devices. It is not intended to be a comprehensive reference source. To complement the information in this data sheet, refer to the “*dsPIC33/PIC24 Family Reference Manual*”, “**CPU**” (DS70359), which is available from the Microchip web site (www.microchip.com).

2: Some registers and associated bits described in this section may not be available on all devices. Refer to **Section 4.0 “Memory Organization”** in this data sheet for device-specific register and bit information.

The CPU has a 16-bit (data) modified Harvard architecture with an enhanced instruction set, including significant support for digital signal processing. The CPU has a 24-bit instruction word, with a variable length opcode field. The Program Counter (PC) is 23 bits wide and addresses up to 4M x 24 bits of user program memory space.

An instruction prefetch mechanism helps maintain throughput and provides predictable execution. Most instructions execute in a single-cycle, effective execution rate, with the exception of instructions that change the program flow, the double-word move (MOV.D) instruction, PSV accesses and the table instructions. Overhead-free program loop constructs are supported using the DO and REPEAT instructions, both of which are interruptible at any point.

3.1 Registers

The dsPIC33EPXXXGM3XX/6XX/7XX devices have sixteen 16-bit Working registers in the programmer's model. Each of the Working registers can act as a data, address or address offset register. The 16th Working register (W15) operates as a Software Stack Pointer for interrupts and calls.

3.2 Instruction Set

The device instruction set has two classes of instructions: the MCU class of instructions and the DSP class of instructions. These two instruction classes are seamlessly integrated into the architecture and execute from a single execution unit. The instruction set includes many addressing modes and was designed for optimum C compiler efficiency.

3.3 Data Space Addressing

The Base Data Space can be addressed as 4K words or 8 Kbytes and is split into two blocks, referred to as X and Y data memory. Each memory block has its own independent Address Generation Unit (AGU). The MCU class of instructions operate solely through the X memory AGU, which accesses the entire memory map as one linear Data Space. On dsPIC33EP devices, certain DSP instructions operate through the X and Y AGUs to support dual operand reads, which splits the data address space into two parts. The X and Y Data Space boundary is device-specific.

The upper 32 Kbytes of the Data Space memory map can optionally be mapped into Program Space at any 16K program word boundary. The program-to-Data Space mapping feature, known as Program Space Visibility (PSV), lets any instruction access Program Space as if it were Data Space. Moreover, the Base Data Space address is used in conjunction with a Data Space Read or Write Page register (DSRPAG or DSWPAG) to form an Extended Data Space (EDS) address. The EDS can be addressed as 8M words or 16 Mbytes. Refer to “**Data Memory**” (DS70595) and “**Program Memory**” (DS70613) in the “*dsPIC33/PIC24 Family Reference Manual*” for more details on EDS, PSV and table accesses.

On dsPIC33EP devices, overhead-free circular buffers (Modulo Addressing) are supported in both X and Y address spaces. The Modulo Addressing removes the software boundary checking overhead for DSP algorithms. The X AGU circular addressing can be used with any of the MCU class of instructions. The X AGU also supports Bit-Reversed Addressing to greatly simplify input or output data reordering for radix-2 FFT algorithms.

3.4 Addressing Modes

The CPU supports these addressing modes:

- Inherent (no operand)
- Relative
- Literal
- Memory Direct
- Register Direct
- Register Indirect

Each instruction is associated with a predefined addressing mode group, depending upon its functional requirements. As many as six addressing modes are supported for each instruction.

dsPIC33EPXXXGM3XX/6XX/7XX

FIGURE 3-1: dsPIC33EPXXXGM3XX/6XX/7XX CPU BLOCK DIAGRAM

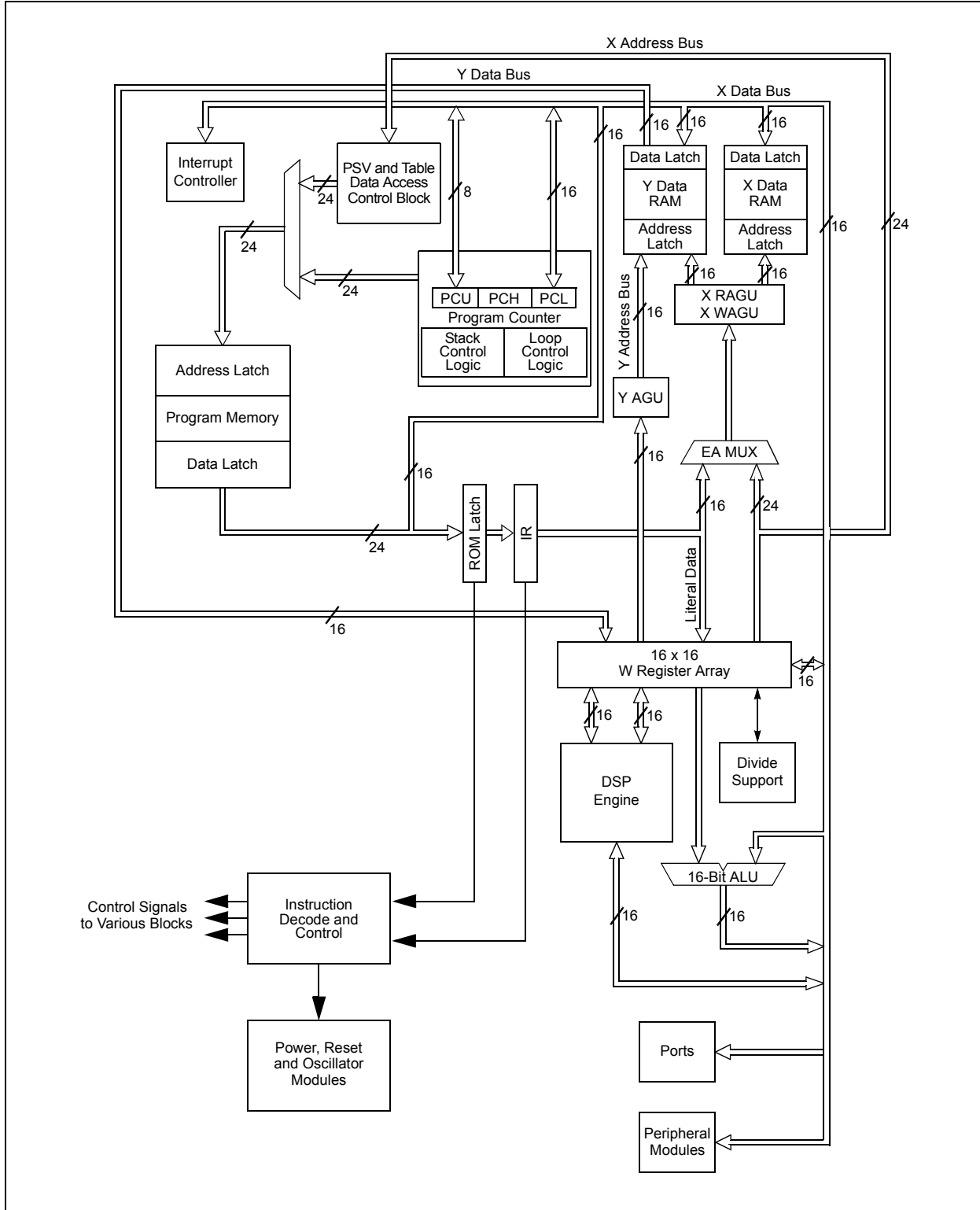

3.5 Programmer's Model

The programmer's model for the dsPIC33EPXXXGM3XX/6XX/7XX devices is shown in [Figure 3-2](#). All registers in the programmer's model are memory-mapped and can be manipulated directly by instructions. [Table 3-1](#) lists a description of each register.

In addition to the registers contained in the programmer's model, the dsPIC33EPXXXGM3XX/6XX/7XX devices contain control registers for Modulo

Addressing and Bit-Reversed Addressing, and interrupts. These registers are described in subsequent sections of this document.

All registers associated with the programmer's model are memory-mapped, as shown in [Table 4-1](#).

TABLE 3-1: PROGRAMMER'S MODEL REGISTER DESCRIPTIONS

Register(s) Name	Description
W0 through W15	Working Register Array
ACCA, ACCB	40-Bit DSP Accumulators
PC	23-Bit Program Counter
SR	ALU and DSP Engine Status register
SPLIM	Stack Pointer Limit Value register
TBLPAG	Table Memory Page Address register
DSRPAG	Extended Data Space (EDS) Read Page register
DSWPAG	Extended Data Space (EDS) Write Page register
RCOUNT	REPEAT Loop Count register
DCOUNT	DO Loop Count register
DOSTARTH ⁽¹⁾ , DOSTARTL ⁽¹⁾	DO Loop Start Address register (High and Low)
DOENDH, DOENDL	DO Loop End Address register (High and Low)
CORCON	Contains DSP Engine, DO Loop Control and Trap Status bits

Note 1: The DOSTARTH and DOSTARTL registers are read-only.

dsPIC33EPXXXGM3XX/6XX/7XX

FIGURE 3-2: PROGRAMMER'S MODEL

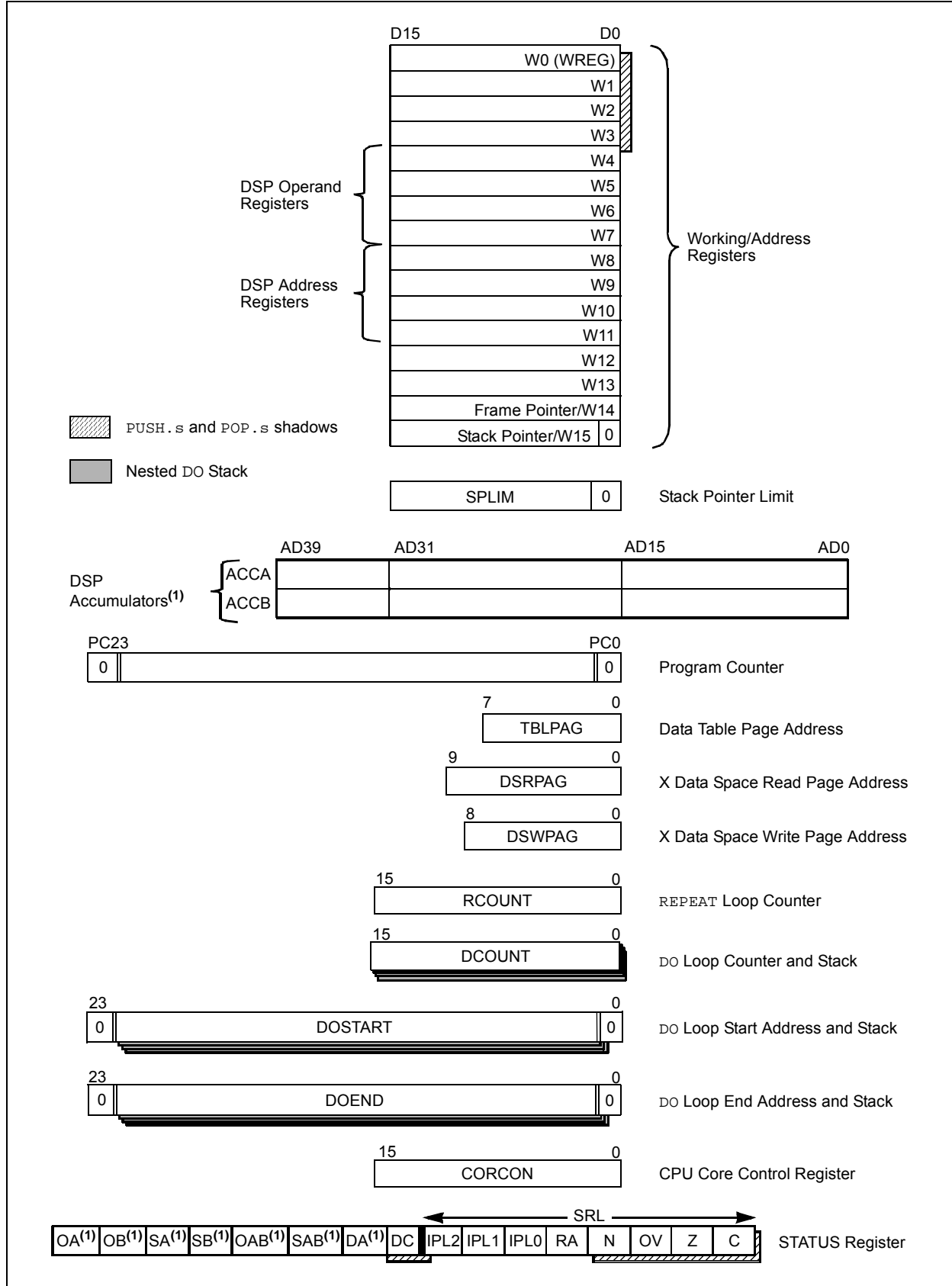

3.6 CPU Control Registers

REGISTER 3-1: SR: CPU STATUS REGISTER

R/W-0	R/W-0	R/W-0	R/W-0	R/C-0	R/C-0	R-0	R/W-0
OA	OB	SA ⁽³⁾	SB ⁽³⁾	OAB	SAB	DA	DC
bit 15							bit 8

R/W-0 ⁽²⁾	R/W-0 ⁽²⁾	R/W-0 ⁽²⁾	R-0	R/W-0	R/W-0	R/W-0	R/W-0
IPL2 ⁽¹⁾	IPL1 ⁽¹⁾	IPL0 ⁽¹⁾	RA	N	OV	Z	C
bit 7							bit 0

Legend:	C = Clearable bit	U = Unimplemented bit, read as '0'
R = Readable bit	W = Writable bit	'0' = Bit is cleared
-n = Value at POR	'1' = Bit is set	x = Bit is unknown

- bit 15 **OA:** Accumulator A Overflow Status bit
 1 = Accumulator A has overflowed
 0 = Accumulator A has not overflowed
- bit 14 **OB:** Accumulator B Overflow Status bit
 1 = Accumulator B has overflowed
 0 = Accumulator B has not overflowed
- bit 13 **SA:** Accumulator A Saturation 'Sticky' Status bit⁽³⁾
 1 = Accumulator A is saturated or has been saturated at some time
 0 = Accumulator A is not saturated
- bit 12 **SB:** Accumulator B Saturation 'Sticky' Status bit⁽³⁾
 1 = Accumulator B is saturated or has been saturated at some time
 0 = Accumulator B is not saturated
- bit 11 **OAB:** OA || OB Combined Accumulator Overflow Status bit
 1 = Accumulator A or B has overflowed
 0 = Neither Accumulator A or B has overflowed
- bit 10 **SAB:** SA || SB Combined Accumulator 'Sticky' Status bit
 1 = Accumulator A or B is saturated or has been saturated at some time
 0 = Neither Accumulator A or B is saturated
- bit 9 **DA:** DO Loop Active bit
 1 = DO loop in progress
 0 = DO loop not in progress
- bit 8 **DC:** MCU ALU Half Carry/Borrow bit
 1 = A carry-out from the 4th low-order bit (for byte-sized data) or 8th low-order bit (for word-sized data) of the result occurred
 0 = No carry-out from the 4th low-order bit (for byte-sized data) or 8th low-order bit (for word-sized data) of the result occurred

- Note 1:** The IPL<2:0> bits are concatenated with the IPL<3> bit (CORCON<3>) to form the CPU Interrupt Priority Level. The value in parentheses indicates the IPL, if IPL<3> = 1. User interrupts are disabled when IPL<3> = 1.
- 2:** The IPL<2:0> Status bits are read-only when the NSTDIS bit (INTCON1<15>) = 1.
- 3:** A data write to the SR register can modify the SA and SB bits by either a data write to SA and SB or by clearing the SAB bit. To avoid a possible SA or SB bit write race condition, the SA and SB bits should not be modified using bit operations.

dsPIC33EPXXXGM3XX/6XX/7XX

REGISTER 3-1: SR: CPU STATUS REGISTER (CONTINUED)

- bit 7-5 **IPL<2:0>**: CPU Interrupt Priority Level Status bits^(1,2)
- 111 = CPU Interrupt Priority Level is 7 (15); user interrupts are disabled
 - 110 = CPU Interrupt Priority Level is 6 (14)
 - 101 = CPU Interrupt Priority Level is 5 (13)
 - 100 = CPU Interrupt Priority Level is 4 (12)
 - 011 = CPU Interrupt Priority Level is 3 (11)
 - 010 = CPU Interrupt Priority Level is 2 (10)
 - 001 = CPU Interrupt Priority Level is 1 (9)
 - 000 = CPU Interrupt Priority Level is 0 (8)
- bit 4 **RA**: REPEAT Loop Active bit
- 1 = REPEAT loop is in progress
 - 0 = REPEAT loop is not in progress
- bit 3 **N**: MCU ALU Negative bit
- 1 = Result was negative
 - 0 = Result was non-negative (zero or positive)
- bit 2 **OV**: MCU ALU Overflow bit
- This bit is used for signed arithmetic (2's complement). It indicates an overflow of the magnitude that causes the sign bit to change state.
- 1 = Overflow occurred for signed arithmetic (in this arithmetic operation)
 - 0 = No overflow occurred
- bit 1 **Z**: MCU ALU Zero bit
- 1 = An operation that affects the Z bit has set it at some time in the past
 - 0 = The most recent operation that affects the Z bit has cleared it (i.e., a non-zero result)
- bit 0 **C**: MCU ALU Carry/Borrow bit
- 1 = A carry-out from the Most Significant bit (MSb) of the result occurred
 - 0 = No carry-out from the Most Significant bit of the result occurred

- Note 1:** The IPL<2:0> bits are concatenated with the IPL<3> bit (CORCON<3>) to form the CPU Interrupt Priority Level. The value in parentheses indicates the IPL, if IPL<3> = 1. User interrupts are disabled when IPL<3> = 1.
- 2:** The IPL<2:0> Status bits are read-only when the NSTDIS bit (INTCON1<15>) = 1.
- 3:** A data write to the SR register can modify the SA and SB bits by either a data write to SA and SB or by clearing the SAB bit. To avoid a possible SA or SB bit write race condition, the SA and SB bits should not be modified using bit operations.

dsPIC33EPXXXGM3XX/6XX/7XX

REGISTER 3-2: CORCON: CORE CONTROL REGISTER⁽³⁾

R/W-0	U-0	R/W-0	R/W-0	R/W-0	R-0	R-0	R-0
VAR	—	US1	US0	EDT ⁽¹⁾	DL2	DL1	DL0
bit 15							bit 8

R/W-0	R/W-0	R/W-1	R/W-0	R/C-0	R-0	R/W-0	R/W-0
SATA	SATB	SATDW	ACCSAT	IPL3 ⁽²⁾	SFA	RND	IF
bit 7							bit 0

Legend:	C = Clearable bit
R = Readable bit	W = Writable bit
-n = Value at POR	'1' = Bit is set
	U = Unimplemented bit, read as '0'
	'0' = Bit is cleared
	x = Bit is unknown

- bit 15 **VAR:** Variable Exception Processing Latency Control bit
 1 = Variable exception processing latency is enabled
 0 = Fixed exception processing latency is enabled
- bit 14 **Unimplemented:** Read as '0'
- bit 13-12 **US<1:0>:** DSP Multiply Unsigned/Signed Control bits
 11 = Reserved
 10 = DSP engine multiplies are mixed-sign
 01 = DSP engine multiplies are unsigned
 00 = DSP engine multiplies are signed
- bit 11 **EDT:** Early DO Loop Termination Control bit⁽¹⁾
 1 = Terminates executing DO loop at end of current loop iteration
 0 = No effect
- bit 10-8 **DL<2:0>:** DO Loop Nesting Level Status bits
 111 = 7 DO loops are active
 •
 •
 •
 001 = 1 DO loop is active
 000 = 0 DO loops are active
- bit 7 **SATA:** ACCA Saturation Enable bit
 1 = Accumulator A saturation is enabled
 0 = Accumulator A saturation is disabled
- bit 6 **SATB:** ACCB Saturation Enable bit
 1 = Accumulator B saturation is enabled
 0 = Accumulator B saturation is disabled
- bit 5 **SATDW:** Data Space Write from DSP Engine Saturation Enable bit
 1 = Data Space write saturation is enabled
 0 = Data Space write saturation is disabled
- bit 4 **ACCSAT:** Accumulator Saturation Mode Select bit
 1 = 9.31 saturation (super saturation)
 0 = 1.31 saturation (normal saturation)

- Note 1:** This bit is always read as '0'.
- 2:** The IPL3 bit is concatenated with the IPL<2:0> bits (SR<7:5>) to form the CPU Interrupt Priority Level.
- 3:** Refer to the “dsPIC33/PIC24 Family Reference Manual”, “CPU” (DS70359) for more detailed information.

dsPIC33EPXXXGM3XX/6XX/7XX

REGISTER 3-2: CORCON: CORE CONTROL REGISTER⁽³⁾ (CONTINUED)

- bit 3 **IPL3**: CPU Interrupt Priority Level Status bit 3⁽²⁾
1 = CPU Interrupt Priority Level is greater than 7
0 = CPU Interrupt Priority Level is 7 or less
- bit 2 **SFA**: Stack Frame Active Status bit
1 = Stack frame is active; W14 and W15 address 0x0000 to 0xFFFF, regardless of DSRPAG and DSWPAG values
0 = Stack frame is not active; W14 and W15 address of EDS or Base Data Space
- bit 1 **RND**: Rounding Mode Select bit
1 = Biased (conventional) rounding is enabled
0 = Unbiased (convergent) rounding is enabled
- bit 0 **IF**: Integer or Fractional Multiplier Mode Select bit
1 = Integer mode is enabled for DSP multiply
0 = Fractional mode is enabled for DSP multiply

- Note 1:** This bit is always read as '0'.
2: The IPL3 bit is concatenated with the IPL<2:0> bits (SR<7:5>) to form the CPU Interrupt Priority Level.
3: Refer to the “*dsPIC33/PIC24 Family Reference Manual*”, “**CPU**” (DS70359) for more detailed information.

3.7 Arithmetic Logic Unit (ALU)

The dsPIC33EPXXXGM3XX/6XX/7XX family ALU is 16 bits wide and is capable of addition, subtraction, bit shifts and logic operations. Unless otherwise mentioned, arithmetic operations are two's complement in nature. Depending on the operation, the ALU can affect the values of the Carry (C), Zero (Z), Negative (N), Overflow (OV) and Digit Carry (DC) Status bits in the SR register. The C and DC Status bits operate as Borrow and Digit Borrow bits, respectively, for subtraction operations.

The ALU can perform 8-bit or 16-bit operations, depending on the mode of the instruction that is used. Data for the ALU operation can come from the W register array or data memory, depending on the addressing mode of the instruction. Likewise, output data from the ALU can be written to the W register array or a data memory location.

Refer to the "16-bit MCU and DSC Programmer's Reference Manual" (DS70157) for information on the SR bits affected by each instruction.

The core CPU incorporates hardware support for both multiplication and division. This includes a dedicated hardware multiplier and support hardware for 16-bit divisor division.

3.7.1 MULTIPLIER

Using the high-speed, 17-bit x 17-bit multiplier, the ALU supports unsigned, signed, or mixed-sign operation in several MCU multiplication modes:

- 16-bit x 16-bit signed
- 16-bit x 16-bit unsigned
- 16-bit signed x 5-bit (literal) unsigned
- 16-bit signed x 16-bit unsigned
- 16-bit unsigned x 5-bit (literal) unsigned
- 16-bit unsigned x 16-bit signed
- 8-bit unsigned x 8-bit unsigned

3.7.2 DIVIDER

The divide block supports 32-bit/16-bit and 16-bit/16-bit signed and unsigned integer divide operations with the following data sizes:

- 32-bit signed/16-bit signed divide
- 32-bit unsigned/16-bit unsigned divide
- 16-bit signed/16-bit signed divide
- 16-bit unsigned/16-bit unsigned divide

The quotient for all divide instructions ends up in W0 and the remainder in W1. 16-bit signed and unsigned DIV instructions can specify any W register for both the 16-bit divisor (Wn) and any W register (aligned) pair (W(m + 1):Wm) for the 32-bit dividend. The divide algorithm takes one cycle per bit of divisor, so both 32-bit/16-bit and 16-bit/16-bit instructions take the same number of cycles to execute.

3.8 DSP Engine

The DSP engine consists of a high-speed, 17-bit x 17-bit multiplier, a 40-bit barrel shifter and a 40-bit adder/subtractor (with two target accumulators, round and saturation logic).

The DSP engine can also perform inherent accumulator-to-accumulator operations that require no additional data. These instructions are ADD, SUB and NEG.

The DSP engine has options selected through bits in the CPU Core Control register (CORCON), as listed below:

- Fractional or integer DSP multiply (IF)
- Signed, unsigned or mixed-sign DSP multiply (US)
- Conventional or convergent rounding (RND)
- Automatic saturation on/off for ACCA (SATA)
- Automatic saturation on/off for ACCB (SATB)
- Automatic saturation on/off for writes to data memory (SATDW)
- Accumulator Saturation mode selection (ACCSAT)

TABLE 3-2: DSP INSTRUCTIONS SUMMARY

Instruction	Algebraic Operation	ACC Write Back
CLR	$A = 0$	Yes
ED	$A = (x - y)^2$	No
EDAC	$A = A + (x - y)^2$	No
MAC	$A = A + (x \cdot y)$	Yes
MAC	$A = A + x^2$	No
MOVSAC	No change in A	Yes
MPY	$A = x \cdot y$	No
MPY.N	$A = -x \cdot y$	No
MSC	$A = A - x \cdot y$	Yes

dsPIC33EPXXGM3XX/6XX/7XX

NOTES:

4.0 MEMORY ORGANIZATION

Note: This data sheet summarizes the features of the dsPIC33EPXXXGM3XX/6XX/7XX family of devices. It is not intended to be a comprehensive reference source. To complement the information in this data sheet, refer to the “dsPIC33/PIC24 Family Reference Manual”, “Program Memory” (DS70613), which is available from the Microchip web site (www.microchip.com).

The dsPIC33EPXXXGM3XX/6XX/7XX family architecture features separate program and data memory spaces and buses. This architecture also allows the direct access of program memory from the Data Space (DS) during code execution.

4.1 Program Address Space

The program address memory space of the dsPIC33EPXXXGM3XX/6XX/7XX devices is 4M instructions. The space is addressable by a 24-bit value derived either from the 23-bit PC during program execution, or from table operation or Data Space remapping, as described in [Section 4.7 “Interfacing Program and Data Memory Spaces”](#).

User application access to the program memory space is restricted to the lower half of the address range (0x000000 to 0x7FFFFFFF). The exception is the use of TBLRD operations, which use TBLPAG<7> to read Device ID sections of the configuration memory space.

The program memory maps, which are presented by device family and memory size, are shown in [Figure 4-1](#) through [Figure 4-3](#).

FIGURE 4-1: PROGRAM MEMORY MAP FOR dsPIC33EP128GM3XX/6XX/7XX DEVICES⁽¹⁾

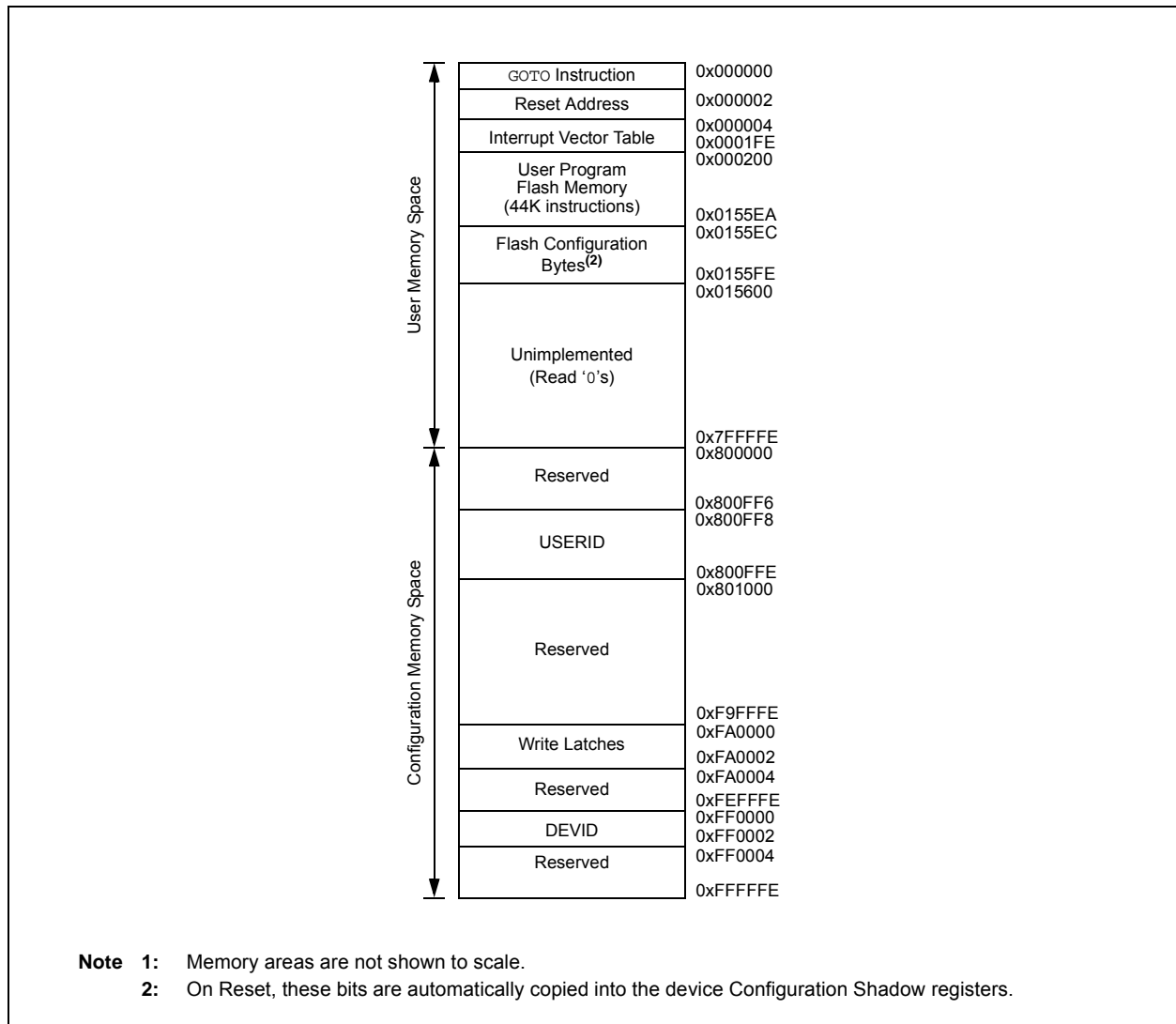

dsPIC33EPXXXGM3XX/6XX/7XX

FIGURE 4-2: PROGRAM MEMORY MAP FOR dsPIC33EP256GM3XX/6XX/7XX DEVICES⁽¹⁾

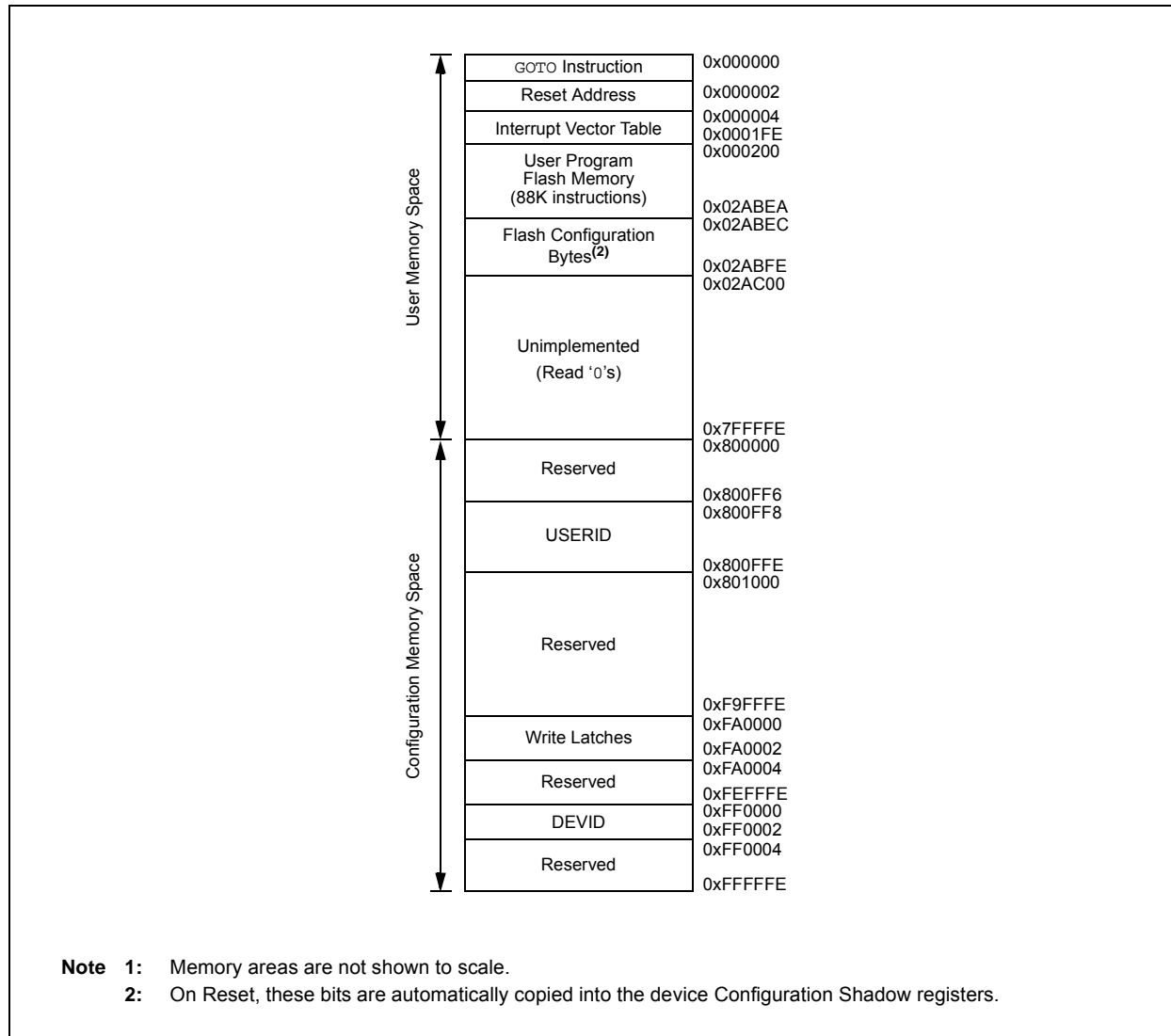

Note 1: Memory areas are not shown to scale.

Note 2: On Reset, these bits are automatically copied into the device Configuration Shadow registers.

dsPIC33EPXXXGM3XX/6XX/7XX

FIGURE 4-3: PROGRAM MEMORY MAP FOR dsPIC33EP512GM3XX/6XX/7XX DEVICES⁽¹⁾

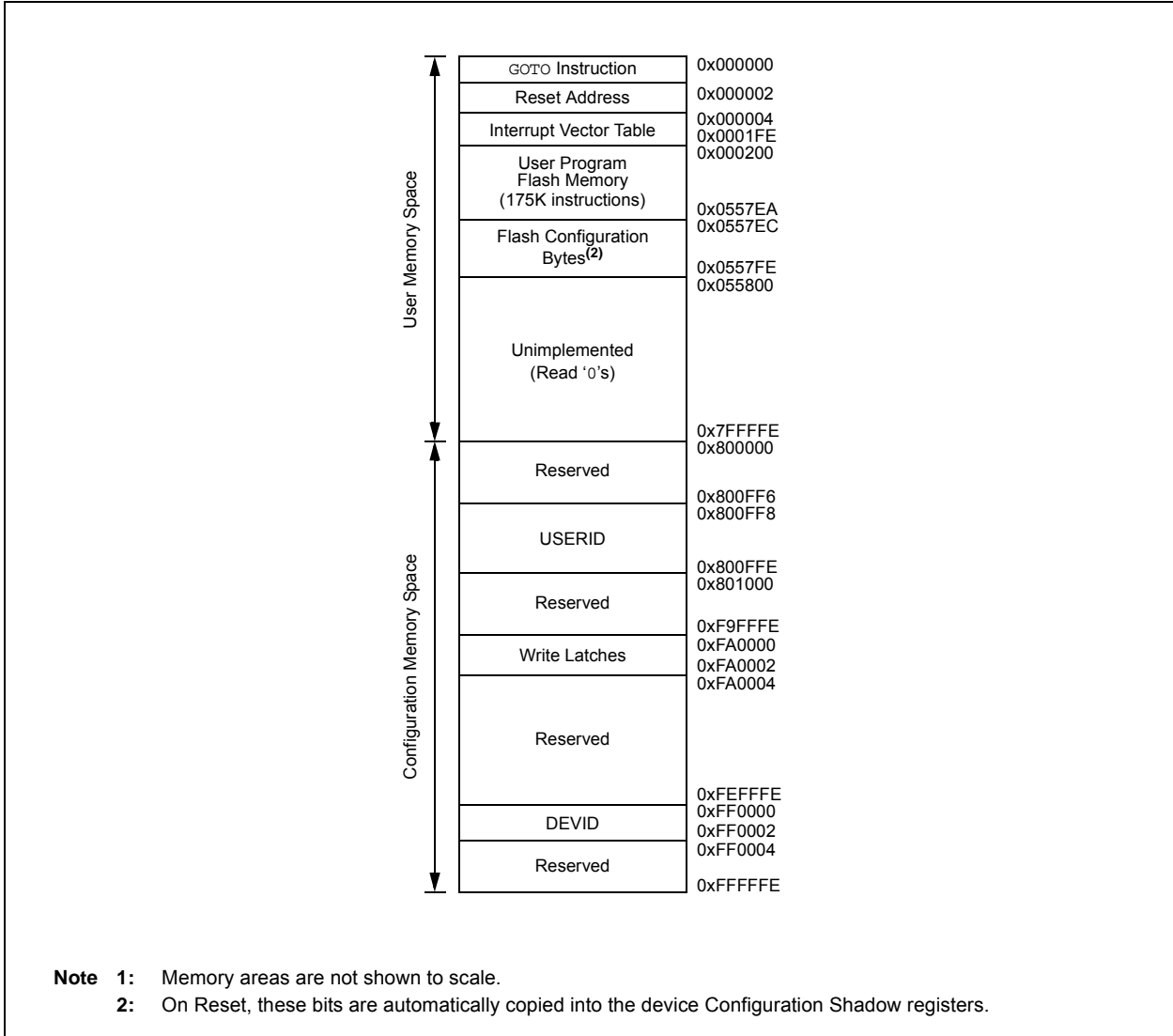

dsPIC33EPXXXGM3XX/6XX/7XX

4.1.1 PROGRAM MEMORY ORGANIZATION

The program memory space is organized in word-addressable blocks. Although it is treated as 24 bits wide, it is more appropriate to think of each address of the program memory as a lower and upper word, with the upper byte of the upper word being unimplemented. The lower word always has an even address, while the upper word has an odd address (Figure 4-4).

Program memory addresses are always word-aligned on the lower word and addresses are incremented or decremented by two during code execution. This arrangement provides compatibility with data memory space addressing and makes data in the program memory space accessible.

4.1.2 INTERRUPT AND TRAP VECTORS

All dsPIC33EPXXXGM3XX/6XX/7XX devices reserve the addresses between 0x000000 and 0x000200 for hard-coded program execution vectors. A hardware Reset vector is provided to redirect code execution from the default value of the PC on device Reset to the actual start of code. A GOTO instruction is programmed by the user application at address, 0x000000 of Flash memory, with the actual address for the start of code at address, 0x000002 of Flash memory.

A more detailed discussion of the interrupt vector tables is provided in Section 7.1 “Interrupt Vector Table”.

FIGURE 4-4: PROGRAM MEMORY ORGANIZATION

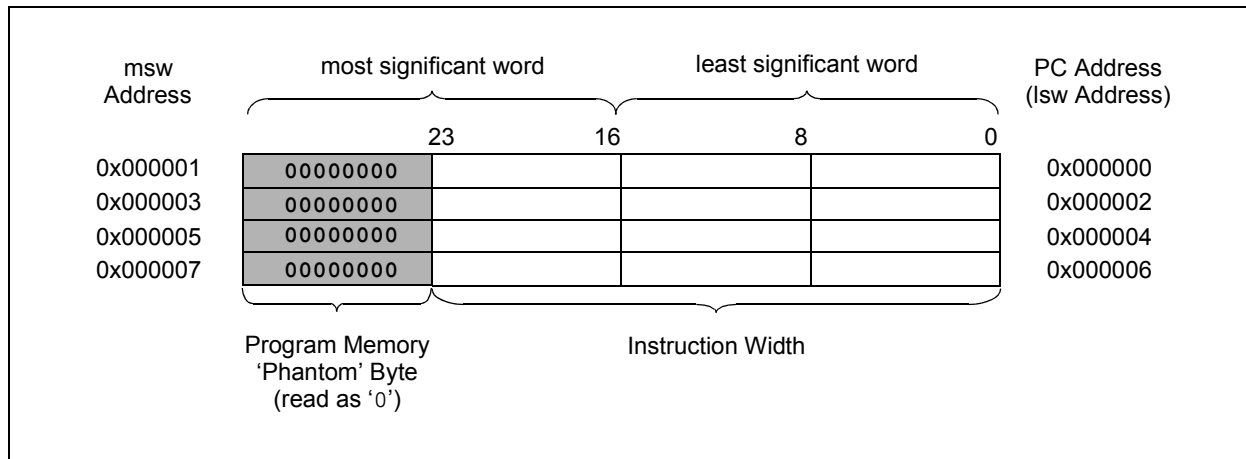

4.2 Data Address Space

The dsPIC33EPXXXGM3XX/6XX/7XX CPU has a separate 16-bit wide data memory space. The Data Space is accessed using separate Address Generation Units (AGUs) for read and write operations. The data memory maps, which are presented by device family and memory size, are shown in Figure 4-5 through Figure 4-7.

All Effective Addresses (EAs) in the data memory space are 16 bits wide and point to bytes within the Data Space. This arrangement gives a Base Data Space address range of 64 Kbytes or 32K words.

The Base Data Space address is used in conjunction with a Data Space Read or Write Page register (DSRPAG or DSWPAG) to form an Extended Data Space, which has a total address range of 16 Mbytes.

dsPIC33EPXXXGM3XX/6XX/7XX devices implement up to 52 Kbytes of data memory (4 Kbytes of data memory for Special Function Registers and up to 48 Kbytes of data memory for RAM). If an EA points to a location outside of this area, an all zero word or byte is returned.

4.2.1 DATA SPACE WIDTH

The data memory space is organized in byte-addressable, 16-bit wide blocks. Data is aligned in data memory and registers as 16-bit words, but all Data Space EAs resolve to bytes. The Least Significant Bytes (LSBs) of each word have even addresses, while the Most Significant Bytes (MSBs) have odd addresses.

4.2.2 DATA MEMORY ORGANIZATION AND ALIGNMENT

To maintain backward compatibility with PIC[®] MCU devices and improve Data Space memory usage efficiency, the dsPIC33EPXXXGM3XX/6XX/7XX instruction set supports both word and byte operations. As a consequence of byte accessibility, all Effective Address calculations are internally scaled to step through word-aligned memory. For example, the core recognizes that Post-Modified Register Indirect Addressing mode [Ws++] results in a value of Ws + 1 for byte operations and Ws + 2 for word operations.

A data byte read, reads the complete word that contains the byte, using the LSb of any EA to determine which byte to select. The selected byte is placed onto the LSB of the data path. That is, data memory and registers are organized as two parallel, byte-wide entities with shared (word) address decode but separate write lines. Data byte writes only write to the corresponding side of the array or register that matches the byte address.

All word accesses must be aligned to an even address. Misaligned word data fetches are not supported, so care must be taken when mixing byte and word operations, or translating from 8-bit MCU code. If a misaligned read or write is attempted, an address error trap is generated. If the error occurred on a read, the instruction underway is completed. If the error occurred on a write, the instruction is executed but the write does not occur. In either case, a trap is then executed, allowing the system and/or user application to examine the machine state prior to execution of the address Fault.

All byte loads into any W register are loaded into the LSB; the MSB is not modified.

A Sign-Extend (SE) instruction is provided to allow user applications to translate 8-bit signed data to 16-bit signed values. Alternatively, for 16-bit unsigned data, user applications can clear the MSB of any W register by executing a Zero-Extend (ZE) instruction on the appropriate address.

4.2.3 SFR SPACE

The first 4 Kbytes of the Near Data Space, from 0x0000 to 0x0FFF, is primarily occupied by Special Function Registers (SFRs). These are used by the dsPIC33EPXXXGM3XX/6XX/7XX core and peripheral modules for controlling the operation of the device.

SFRs are distributed among the modules that they control and are generally grouped together by module. Much of the SFR space contains unused addresses; these are read as '0'.

Note: The actual set of peripheral features and interrupts varies by the device. Refer to the corresponding device tables and pinout diagrams for device-specific information.

4.2.4 NEAR DATA SPACE

The 8-Kbyte area, between 0x0000 and 0x1FFF, is referred to as the Near Data Space. Locations in this space are directly addressable through a 13-bit absolute address field within all memory direct instructions. Additionally, the whole Data Space is addressable using MOV instructions, which support Memory Direct Addressing mode with a 16-bit address field, or by using Indirect Addressing mode using a Working register as an Address Pointer.

dsPIC33EPXXXGM3XX/6XX/7XX

FIGURE 4-5: DATA MEMORY MAP FOR 128-KBYTE DEVICES

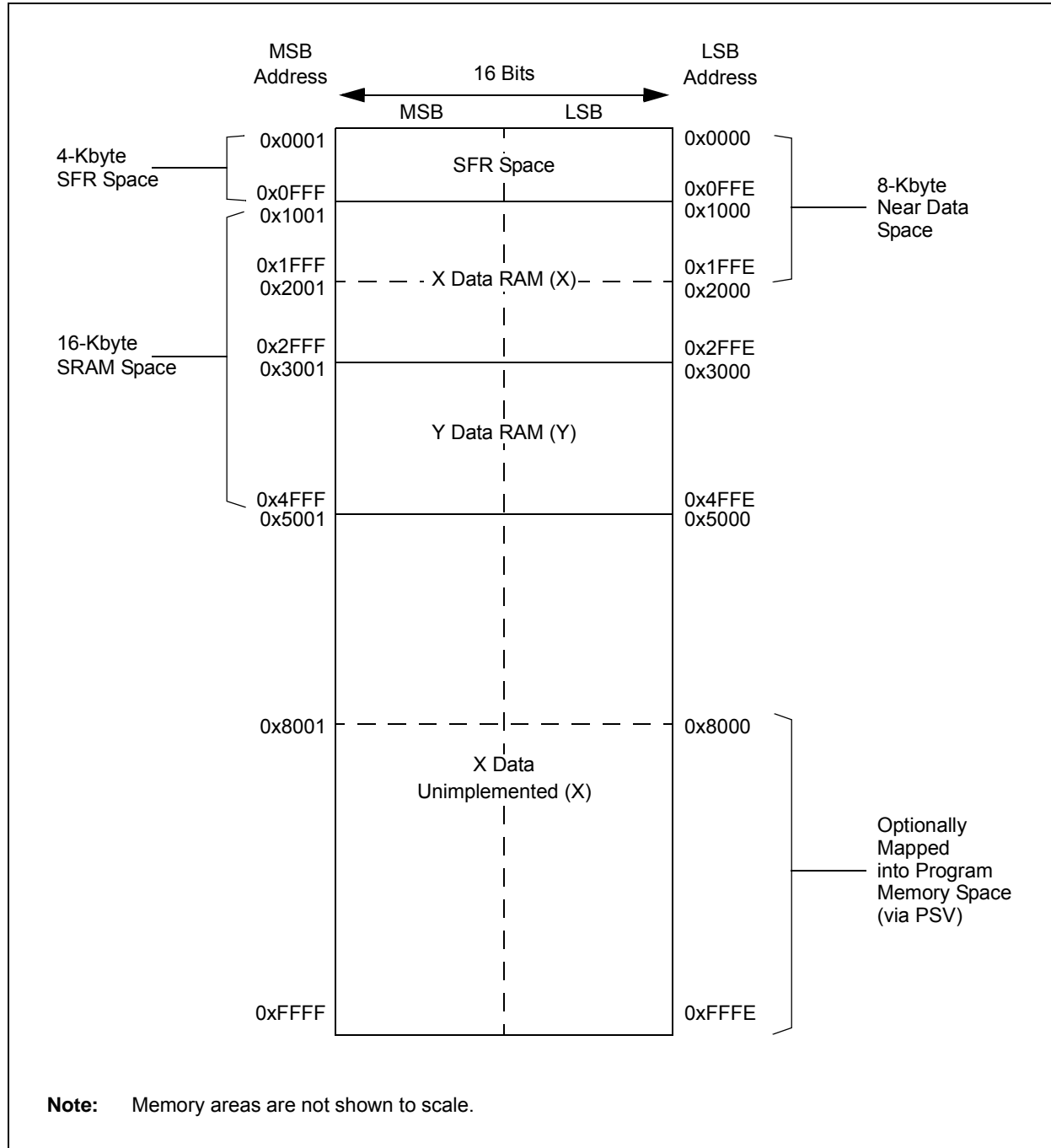
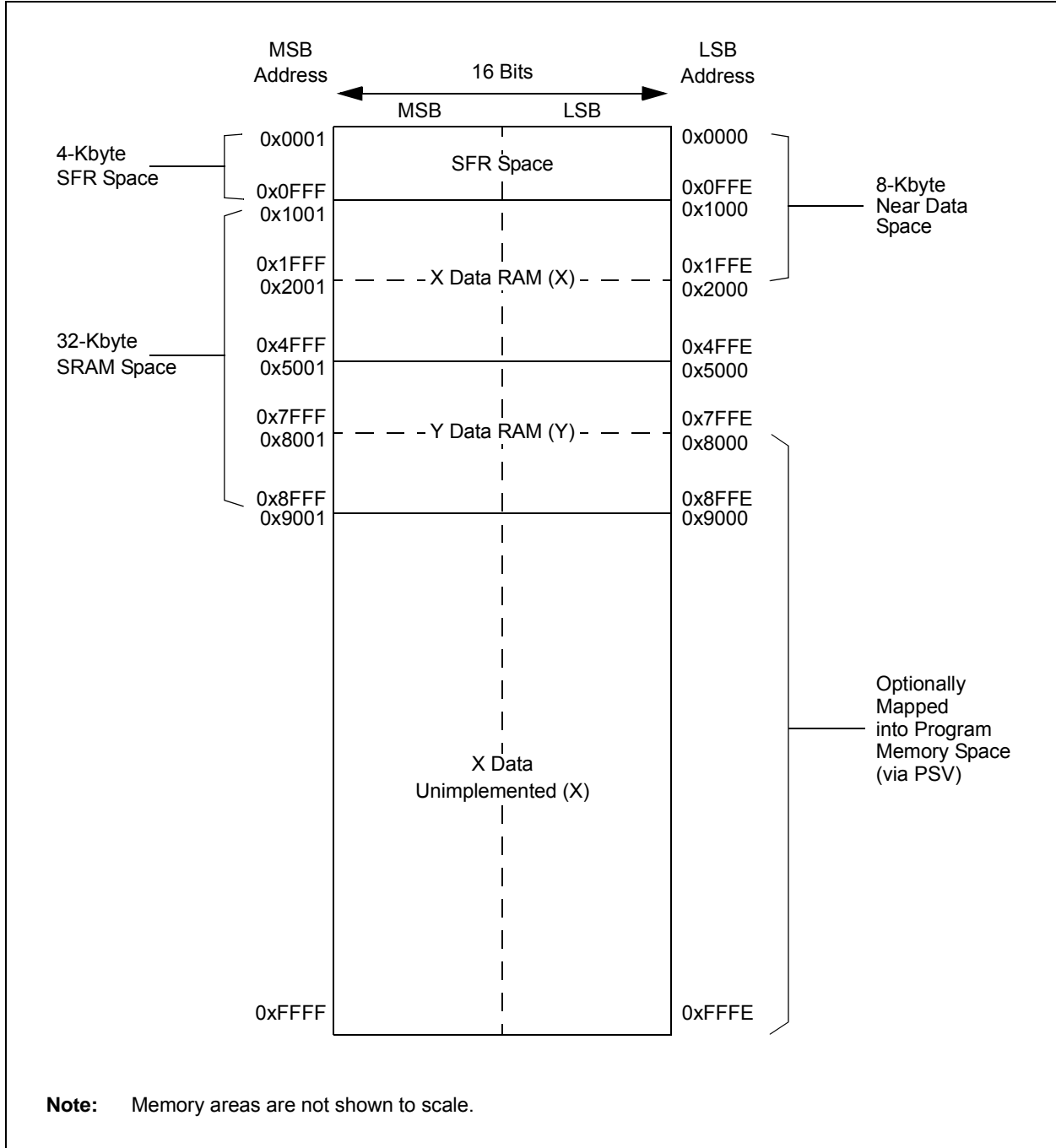
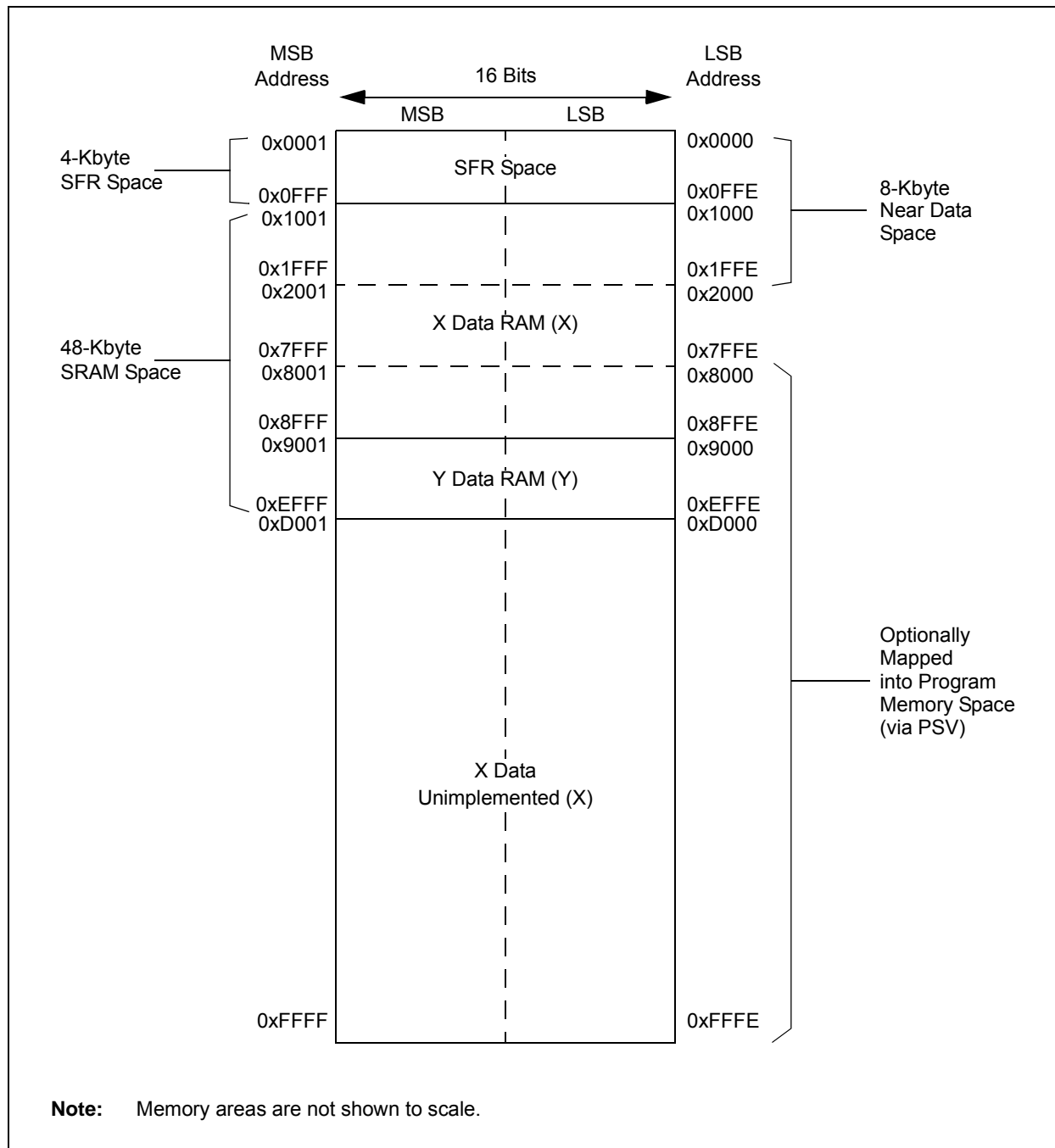

FIGURE 4-6: DATA MEMORY MAP FOR 256-KBYTE DEVICES



dsPIC33EPXXXGM3XX/6XX/7XX

FIGURE 4-7: DATA MEMORY MAP FOR 512-KBYTE DEVICES



4.2.5 X AND Y DATA SPACES

The dsPIC33EP core has two Data Spaces: X and Y. These Data Spaces can be considered either separate (for some DSP instructions) or as one unified linear address range (for MCU instructions). The Data Spaces are accessed using two Address Generation Units (AGUs) and separate data paths. This feature allows certain instructions to concurrently fetch two words from RAM, thereby enabling efficient execution of DSP algorithms, such as Finite Impulse Response (FIR) filtering and Fast Fourier Transform (FFT).

The X Data Space is used by all instructions and supports all addressing modes. The X Data Space has separate read and write data buses. The X read data bus is the read data path for all instructions that view Data Space as combined X and Y address space. It is also the X data prefetch path for the dual operand DSP instructions (MAC class).

The Y Data Space is used in concert with the X Data Space by the MAC class of instructions (CLR, ED, EDAC, MAC, MOV SAC, MPY, MPY.N and MSC) to provide two concurrent data read paths.

Both the X and Y Data Spaces support Modulo Addressing mode for all instructions, subject to addressing mode restrictions. Bit-Reversed Addressing mode is only supported for writes to X Data Space.

All data memory writes, including in DSP instructions, view Data Space as combined X and Y address space. The boundary between the X and Y Data Spaces is device-dependent and is not user-programmable.

4.3 Special Function Register Maps

TABLE 4-1: CPU CORE REGISTER MAP

SFR Name	Addr.	Bit 15	Bit 14	Bit 13	Bit 12	Bit 11	Bit 10	Bit 9	Bit 8	Bit 7	Bit 6	Bit 5	Bit 4	Bit 3	Bit
W0	0000	W0 (WREG)													
W1	0002	W1													
W2	0004	W2													
W3	0006	W3													
W4	0008	W4													
W5	000A	W5													
W6	000C	W6													
W7	000E	W7													
W8	0010	W8													
W9	0012	W9													
W10	0014	W10													
W11	0016	W11													
W12	0018	W12													
W13	001A	W13													
W14	001C	W14													
W15	001E	W15													
SPLIM	0020	SPLIM													
ACCAL	0022	ACCAL													
ACCAH	0024	ACCAH													
ACCAU	0026	Sign Extension of ACCA<39>													
ACCBH	0028	ACCBH													
ACCBU	002A	ACCBH													
ACCBU	002C	Sign Extension of ACCB<39>													
PCL	002E	Program Counter Low Word Register													
PCH	0030	—	—	—	—	—	—	—	—	—	—	—	—	—	Program Counter High Word Register
DSRPAG	0032	—	—	—	—	—	—	—	—	—	—	—	—	—	Data Space Read Page Register
DSWPAG	0034	—	—	—	—	—	—	—	—	—	—	—	—	—	Data Space Write Page Register
RCOUNT	0036	REPEAT Loop Count Register													
DCOUNT	0038	DCOUNT<15:0>													
DOSTARTL	003A	DOSTARTL<15:1>													
DOSTARTH	003C	—	—	—	—	—	—	—	—	—	—	—	—	—	DOSTARTH<5:0>
DOENDL	003E	DOENDL<15:1>													
DOENDH	0040	—	—	—	—	—	—	—	—	—	—	—	—	—	DOENDH<5:0>

Legend: x = unknown value on Reset; — = unimplemented, read as '0'. Reset values are shown in hexadecimal.

TABLE 4-1: CPU CORE REGISTER MAP (CONTINUED)

SFR Name	Addr.	Bit 15	Bit 14	Bit 13	Bit 12	Bit 11	Bit 10	Bit 9	Bit 8	Bit 7	Bit 6	Bit 5	Bit 4	Bit 3	Bit	
SR	0042	OA	OB	SA	SB	OAB	SAB	DA	DC	IDL2	IDL1	IPL0	RA	N	OV	
CORCON	0044	VAR	—	US1	US0	EDT	DL1	DL2	DL0	SATA	SATB	SATDW	ACCSAT	IPL3	SF3	
MODCON	0046	XMODEN	YMODEN	—	—	BWM3	BWM2	BWM1	BWM0	YWM3	YWM2	YWM1	YWM0	XWM3	XWM0	
XMODSRT	0048	XMODSRT<15:0>														
XMODEND	004A	XMODEND<15:0>														
YMODSRT	004C	YMODSRT<15:0>														
YMODEND	004E	YMODEND<15:0>														
XBREV	0050	BREN	XBREV<14:0>													
DISICNT	0052	—	—	DISICNT<13:0>												
TBLPAG	0054	—	—	—	—	—	—	—	—	—	—	—	—	—	TBLPAG<7:0>	
MSTRPR	0058	MSTRPR<15:0>														

Legend: x = unknown value on Reset; — = unimplemented, read as '0'. Reset values are shown in hexadecimal.

TABLE 4-2: INTERRUPT CONTROLLER REGISTER MAP FOR dsPIC33EPXXGM6XXI7XX DEVICES

SFR Name	Addr.	Bit 15	Bit 14	Bit 13	Bit 12	Bit 11	Bit 10	Bit 9	Bit 8	Bit 7	Bit 6	Bit 5	Bit 4	Bit 3	Bit 2
INTCON1	08C0	NSTDIS	OVAERR	OVBERR	COVAERR	COVBERR	OVATE	OVBTE	COVTE	SFTACERR	DIV0ERR	DMACERR	MATHERR	ADDRERR	STKERR
INTCON2	08C2	GIE	DISI	SWTRAP	—	—	—	—	—	—	—	DAE	DOOVR	—	—
INTCON3	08C4	—	—	—	—	—	—	—	—	—	—	—	—	—	—
INTCON4	08C6	—	—	—	—	—	—	—	—	—	—	—	—	—	—
IFS0	0800	—	DMA1IF	AD1IF	U1TXIF	U1RXIF	SP11IF	SP1EIF	T3IF	T2IF	OC2IF	IC2IF	DMA0IF	T1IF	OC1IF
IFS1	0802	U2TXIF	U2RXIF	INT2IF	T5IF	T4IF	OC4IF	OC3IF	DMA2IF	IC8IF	IC7IF	AD2IF	INT1IF	CNIF	CMPIF
IFS2	0804	T6IF	—	PMPIF ⁽¹⁾	OC8IF	OC7IF	OC6IF	OC5IF	IC6IF	IC5IF	IC4IF	IC3IF	DMA3IF	C1IF	C1RXIF
IFS3	0806	FLT1IF	RTCCIF ⁽²⁾	—	DC1IF	DCIEIF	QE11IF	PSEMIF	C2IF	C2RXIF	INT4IF	INT3IF	T9IF	T8IF	M2CCIF
IFS4	0808	—	—	CTMUJIF	FLT4IF	QE2IF	FLT3IF	PSESMIF	—	C2TXIF	C1TXIF	—	—	CRCIF	U2EIF
IFS5	080A	PWM2IF	PWM1IF	—	—	SP3IF	SP3EIF	U4TXIF	U4RXIF	U4EIF	—	—	—	U3TXIF	U3RXIF
IFS6	080C	—	—	—	—	—	—	—	—	—	—	—	—	PWM6IF	PWM5IF
IFS8	0810	JTAGIF	ICDIF	—	—	—	—	—	—	—	—	—	—	—	—
IFS9	0812	—	—	—	—	—	—	—	—	—	—	—	—	—	—
IEC0	0820	—	DMA1IE	AD1IE	U1TXIE	U1RXIE	SP11IE	SP1EIE	T3IE	T2IE	OC2IE	IC2IE	DMA0IE	T1IE	OC1IE
IEC1	0822	U2TXIE	U2RXIE	INT2IE	T5IE	T4IE	OC4IE	OC3IE	DMA2IE	IC8IE	IC7IE	AD2IE	INT1IE	CNIE	CMPIE
IEC2	0824	T6IE	—	PMPIE ⁽¹⁾	OC8IE	OC7IE	OC6IE	OC5IE	IC6IE	IC5IE	IC4IE	IC3IE	DMA3IE	C1IE	C1RXIE
IEC3	0826	FLT1IE	RTCCIE ⁽²⁾	—	DC1IE	DCIEIE	QE11IE	PSEMIIE	C2IE	C2RXIE	INT4IE	INT3IE	T9IE	T8IE	M2CCIE
IEC4	0828	—	—	CTMUJIE	FLT4IE	QE2IE	FLT3IE	PSESMIE	—	C2TXIE	C1TXIE	—	—	CRCIE	U2EIE
IEC5	082A	PWM2IE	PWM1IE	—	—	SP3IE	SP3EIE	U4TXIE	U4RXIE	U4EIE	—	—	—	U3TXIE	U3RXIE
IEC6	082C	—	—	—	—	—	—	—	—	—	—	—	—	PWM6IE	PWM5IE
IEC8	0830	JTAGIE	ICDIE	—	—	—	—	—	—	—	—	—	—	—	—
IEC9	0832	—	—	—	—	—	—	—	—	—	—	—	—	—	—
IPC0	0840	—	T1IP2	T1IP1	T1IP0	—	OC1IP2	OC1IP1	OC1IP0	—	PTG3IE	PTG2IE	PTG1IE	PTG0IE	PTG0MIE
IPC1	0842	—	T2IP2	T2IP1	T2IP0	—	OC2IP2	OC2IP1	OC2IP0	—	IC1IP2	IC1IP1	IC1IP0	—	INT0IF
IPC2	0844	—	U1RXIP2	U1RXIP1	U1RXIP0	—	SP1IP2	SP1IP1	SP1IP0	—	IC2IP2	IC2IP1	IC2IP0	—	DMA0IF
IPC3	0846	—	—	—	—	—	DMA1IP2	DMA1IP1	DMA1IP0	—	SP1IEIP2	SP1IEIP1	SP1IEIP0	—	DMA0IF
IPC4	0848	—	CNIP2	CNIP1	CNIP0	—	CMPIP2	CMPIP1	CMPIP0	—	AD1IP2	AD1IP1	AD1IP0	—	U1TXIF
IPC5	084A	—	IC8IP2	IC8IP1	IC8IP0	—	IC7IP2	IC7IP1	IC7IP0	—	M2C1IP2	M2C1IP1	M2C1IP0	—	S1C2IF
IPC6	084C	—	T4IP2	T4IP1	T4IP0	—	OC4IP2	OC4IP1	OC4IP0	—	AD2IP2	AD2IP1	AD2IP0	—	INT1IF
IPC7	084E	—	U2TXIP2	U2TXIP1	U2TXIP0	—	U2RXIP2	U2RXIP1	U2RXIP0	—	OC3IP2	OC3IP1	OC3IP0	—	DMA2IF
IPC8	0850	—	C1IP2	C1IP1	C1IP0	—	C1RXIP2	C1RXIP1	C1RXIP0	—	INT2IP2	INT2IP1	INT2IP0	—	T5IF
IPC9	0852	—	IC5IP2	IC5IP1	IC5IP0	—	IC4IP2	IC4IP1	IC4IP0	—	SP12IP2	SP12IP1	SP12IP0	—	SP12EIF
IPC10	0854	—	OC7IP2	OC7IP1	OC7IP0	—	OC6IP2	OC6IP1	OC6IP0	—	OC5IP2	OC5IP1	OC5IP0	—	DMA3IF

Legend: — = unimplemented, read as '0'. Reset values are shown in hexadecimal.

Note 1: The PMPIF/PMPIE/PMPIPx flags are not available on 44-pin devices.

2: The RTCCIF/RTCCIE/RTCCIPx flags are not available on 44-pin devices.

TABLE 4-2: INTERRUPT CONTROLLER REGISTER MAP FOR dsPIC33EPXXGM6XX/7XX DEVICES (CONTINUED)

SFR Name	Addr.	Bit 15	Bit 14	Bit 13	Bit 12	Bit 11	Bit 10	Bit 9	Bit 8	Bit 7	Bit 6	Bit 5	Bit 4	Bit 3	Bit
IPC11	0856	—	T6IP2	T6IP1	T6IP0	—	—	—	—	—	PMPIP2 ⁽¹⁾	PMPIP1 ⁽¹⁾	PMPIP0 ⁽¹⁾	—	OC8IF
IPC12	0858	—	T8IP2	T8IP1	T8IP0	—	M12C2IP2	M12C2IP1	M12C2IP0	—	S12C2IP2	S12C2IP1	S12C2IP0	—	T7IP1
IPC13	085A	—	C2RXIP2	C2RXIP1	C2RXIP0	—	INT4IP2	INT4IP1	INT4IP0	—	INT3IP2	INT3IP1	INT3IP0	—	T9IP1
IPC14	085C	—	DCIEIP2	DCIEIP1	DCIEIP0	—	QE1IP2	QE1IP1	QE1IP0	—	PCOEIP2	PCOEIP1	PCOEIP0	—	C2IP1
IPC15	085E	—	FLT1IP2	FLT1IP1	FLT1IP0	—	RTCCIP2 ⁽²⁾	RTCCIP1 ⁽²⁾	RTCCIP0 ⁽²⁾	—	—	—	—	—	DCIIF
IPC16	0860	—	CRCIP2	CRCIP1	CRCIP0	—	U2EIP2	U2EIP1	U2EIP0	—	U1EIP2	U1EIP1	U1EIP0	—	FLT2IIF
IPC17	0862	—	C2TXIP2	C2TXIP1	C2TXIP0	—	C1TXIP2	C1TXIP1	C1TXIP0	—	—	—	—	—	—
IPC18	0864	—	QE2IP2	QE2IP1	QE2IP0	—	FLT3IP2	FLT3IP1	FLT3IP0	—	PCESIP2	PCESIP1	PCESIP0	—	—
IPC19	0866	—	—	—	—	—	—	—	—	—	CTMUJIP2	CTMUJIP1	CTMUJIP0	—	FLT4IIF
IPC20	0868	—	U3TXIP2	U3TXIP1	U3TXIP0	—	U3RXIP2	U3RXIP1	U3RXIP0	—	—	—	—	—	—
IPC21	086A	—	U4EIP2	U4EIP1	U4EIP0	—	—	—	—	—	—	—	—	—	—
IPC22	086C	—	SP13IP2	SP13IP1	SP13IP0	—	SP13EIP2	SP13EIP1	SP13EIP0	—	U4TXIP2	U4TXIP1	U4TXIP0	—	U4RXIIF
IPC23	086E	—	PGC2IP2	PGC2IP1	PGC2IP0	—	PWM1IP2	PWM1IP1	PWM1IP0	—	—	—	—	—	—
IPC24	0870	—	PWM6IP2	PWM6IP1	PWM6IP0	—	PWM5IP2	PWM5IP1	PWM5IP0	—	PWM4IP2	PWM4IP1	PWM4IP0	—	PWM3
IPC35	0886	—	JTAGIP2	JTAGIP1	JTAGIP0	—	ICDIP2	ICDIP1	ICDIP0	—	—	—	—	—	—
IPC36	0888	—	PTG0IP2	PTG0IP1	PTG0IP0	—	PTGWDTIP2	PTGWDTIP1	PTGWDTIP0	—	PTGSTEPIP2	PTGSTEPIP1	PTGSTEPIP0	—	—
IPC37	088A	—	—	—	—	—	PTG3IP2	PTG3IP1	PTG3IP0	—	PTG2IP2	PTG2IP1	PTG2IP0	—	PTG1IIF
INTTREG	08C8	—	—	—	—	ILR3	ILR2	ILR1	ILR0	VECNUM7	VECNUM6	VECNUM5	VECNUM4	VECNUM3	VECNUM

Legend: — = unimplemented, read as '0'. Reset values are shown in hexadecimal.

Note 1: The PMPIE/PMPIE/PMPIE flags are not available on 44-pin devices.

2: The RTCCIF/RTCCIE/RTCCIFx flags are not available on 44-pin devices.

TABLE 4-3: INTERRUPT CONTROLLER REGISTER MAP FOR dsPIC33EPXXGM3XX DEVICES

SFR Name	Addr.	Bit 15	Bit 14	Bit 13	Bit 12	Bit 11	Bit 10	Bit 9	Bit 8	Bit 7	Bit 6	Bit 5	Bit 4	Bit 3	Bit
INTCON1	08C0	NSTDIS	OVAERR	OVBERR	COVAERR	COVBERR	OIVATE	OVBITE	COVTE	SFTACERR	DIVERR	DMACERR	MATHERR	ADDRERR	STKERR
INTCON2	08C2	GIE	DISI	SWTRAP	—	—	—	—	—	—	—	—	—	—	INT2IF
INTCON3	08C4	—	—	—	—	—	—	—	—	—	—	DAE	DOOVR	—	—
INTCON4	08C6	—	—	—	—	—	—	—	—	—	—	—	—	—	—
IFS0	0800	—	DMA1IF	AD1IF	U1TXIF	U1RXIF	SP1IF	SP1EIF	T3IF	T2IF	OC2IF	IC2IF	DMA0IF	T1IF	OC1IF
IFS1	0802	U2TXIF	U2RXIF	INT2IF	T5IF	T4IF	OC4IF	OC3IF	DMA2IF	IC8IF	IC7IF	AD2IF	INT1IF	CNIF	CNIF
IFS2	0804	T6IF	—	PMPIF ⁽¹⁾	OC8IF	OC7IF	OC6IF	OC5IF	IC6IF	IC5IF	IC4IF	IC3IF	DMA3IF	—	—
IFS3	0806	FLT1IF	RTCCIF ⁽²⁾	—	DCIF	DCIEF	QE1IF	PSEMIF	—	—	INT4IF	INT3IF	T9IF	T8IF	M2C
IFS4	0808	—	—	CTMUJIF	FLT4IF	QE2IF	FLT3IF	PSESMIF	—	—	—	—	—	CRCIF	UZE
IFS5	080A	PWM2IF	PWM1IF	—	—	SP3IF	SP3EIF	U4TXIF	U4RXIF	U4EIF	—	—	—	U3TXIF	U3RXIF
IFS6	080C	—	—	—	—	—	—	—	—	—	—	—	—	PWM6IF	PWM
IFS8	0810	JTAGIF	ICDIF	—	—	—	—	—	—	—	—	—	—	—	—
IFS9	0812	—	—	—	—	—	—	—	—	—	PTG3IF	PTG2IF	PTG1IF	PTG0IF	PTGWM
IEC0	0820	—	DMA1IE	AD1IE	U1TXIE	U1RXIE	SP1IE	SP1IEE	T3IE	T2IE	OC2IE	IC2IE	DMA0IE	T1IE	OC1IE
IEC1	0822	U2TXIE	U2RXIE	INT2IE	T5IE	T4IE	OC4IE	OC3IE	DMA2IE	IC8IE	IC7IE	AD2IE	INT1IE	CNIE	CNIF
IEC2	0824	T6IE	—	PMPIE ⁽¹⁾	OC8IE	OC7IE	OC6IE	OC5IE	IC6IE	IC5IE	IC4IE	IC3IE	DMA3IE	—	—
IEC3	0826	FLT1IE	RTCCIE ⁽²⁾	—	DCIE	DCIEE	QE1IE	PSEMIE	—	—	INT4IE	INT3IE	T9IE	T8IE	M2C
IEC4	0828	—	—	CTMUJIE	FLT4IE	QE2IE	FLT3IE	PSESMIE	—	—	—	—	—	CRCIE	UZE
IEC5	082A	PWM2IE	PWM1IE	—	—	SP3IE	SP3EIE	U4TXIE	U4RXIE	U4EIE	—	—	—	U3TXIE	U3RXIE
IEC6	082C	—	—	—	—	—	—	—	—	—	—	—	—	PWM6IE	PWM
IEC8	0830	JTAGIE	ICDIE	—	—	—	—	—	—	—	—	—	—	—	—
IEC9	0832	—	—	—	—	—	—	—	—	—	PTG3IE	PTG2IE	PTG1IE	PTG0IE	PTGWM
IPC0	0840	—	T1IP2	T1IP1	T1IP0	—	OC1IP2	OC1IP1	OC1IP0	—	IC1IP2	IC1IP1	IC1IP0	—	INT0
IPC1	0842	—	T2IP2	T2IP1	T2IP0	—	OC2IP2	OC2IP1	OC2IP0	—	IC2IP2	IC2IP1	IC2IP0	—	DMA0
IPC2	0844	—	U1RXIP2	U1RXIP1	U1RXIP0	—	SP1IP2	SP1IP1	SP1IP0	—	SP1EIF2	SP1EIP1	SP1EIP0	—	T3IF
IPC3	0846	—	—	—	—	—	DMA1IP2	DMA1IP1	DMA1IP0	—	AD1IP2	AD1IP1	AD1IP0	—	U1TX
IPC4	0848	—	CNIP2	CNIP1	CNIP0	—	CMPIP2	CMPIP1	CMPIP0	—	M2C1IP2	M2C1IP1	M2C1IP0	—	S2C
IPC5	084A	—	IC8IP2	IC8IP1	IC8IP0	—	IC7IP2	IC7IP1	IC7IP0	—	AD2IP2	AD2IP1	AD2IP0	—	INT1
IPC6	084C	—	T4IP2	T4IP1	T4IP0	—	OC4IP2	OC4IP1	OC4IP0	—	OC3IP2	OC3IP1	OC3IP0	—	DMA2
IPC7	084E	—	U2TXIP2	U2TXIP1	U2TXIP0	—	U2RXIP2	U2RXIP1	U2RXIP0	—	INT2IP2	INT2IP1	INT2IP0	—	T5IF
IPC8	0850	—	—	—	—	—	—	—	—	—	SP12IP2	SP12IP1	SP12IP0	—	SP12E
IPC9	0852	—	IC5IP2	IC5IP1	IC5IP0	—	IC4IP2	IC4IP1	IC4IP0	—	IC3IP2	IC3IP1	IC3IP0	—	DMA3
IPC10	0854	—	OC7IP2	OC7IP1	OC7IP0	—	OC6IP2	OC6IP1	OC6IP0	—	OC5IP2	OC5IP1	OC5IP0	—	IC6IF

Legend: — = unimplemented, read as '0'. Reset values are shown in hexadecimal.

Note 1: The PMPIF/PMPIE/PMPIPx flags are not available on 44-pin devices.

Note 2: The RTCCIF/RTCCIE/RTCCIFx flags are not available on 44-pin devices.

TABLE 4-3: INTERRUPT CONTROLLER REGISTER MAP FOR dsPIC33EPXXGM3XX DEVICES (CONTINUED)

SFR Name	Addr.	Bit 15	Bit 14	Bit 13	Bit 12	Bit 11	Bit 10	Bit 9	Bit 8	Bit 7	Bit 6	Bit 5	Bit 4	Bit 3	Bit
IPC11	0856	—	T6IP2	T6IP1	T6IP0	—	—	—	—	—	PMPIP2 ⁽¹⁾	PMPIP1 ⁽¹⁾	PMPIP0 ⁽¹⁾	—	OC8
IPC12	0858	—	T8IP2	T8IP1	T8IP0	—	M2C2IP2	M2C2IP1	M2C2IP0	—	S2C2IP2	S2C2IP1	S2C2IP0	—	T7IF
IPC13	085A	—	—	—	—	—	INT4IP2	INT4IP1	INT4IP0	—	INT3IP2	INT3IP1	INT3IP0	—	T9IF
IPC14	085C	—	DCIEIP2	DCIEIP1	DCIEIP0	—	QE1IP2	QE1IP1	QE1IP0	—	PCEIP2	PCEIP1	PCEIP0	—	—
IPC15	085E	—	FLT1IP2	FLT1IP1	FLT1IP0	—	RTCCIP2 ⁽²⁾	RTCCIP1 ⁽²⁾	RTCCIP0 ⁽²⁾	—	—	—	—	—	DCIC
IPC16	0860	—	CRCIP2	CRCIP1	CRCIP0	—	U2EIP2	U2EIP1	U2EIP0	—	U1EIP2	U1EIP1	U1EIP0	—	FLT2
IPC18	0864	—	C2TXIP2	C2TXIP1	C2TXIP0	—	FLT3IP2	FLT3IP1	FLT3IP0	—	PCEIP2	PCEIP1	PCEIP0	—	—
IPC19	0866	—	—	—	—	—	—	—	—	—	CTMUJIP2	CTMUJIP1	CTMUJIP0	—	FLT4
IPC20	0868	—	U3TXIP2	U3TXIP1	U3TXIP0	—	U3RXIP2	U3RXIP1	U3RXIP0	—	U3EIP2	U3EIP1	U3EIP0	—	—
IPC21	086A	—	U4EIP2	U4EIP1	U4EIP0	—	—	—	—	—	—	—	—	—	—
IPC22	086C	—	SPI3IP2	SPI3IP1	SPI3IP0	—	SPI3EIP2	SPI3EIP1	SPI3EIP0	—	U4TXIP2	U4TXIP1	U4TXIP0	—	U4FX
IPC23	086E	—	PGC2IP2	PGC2IP1	PGC2IP0	—	PWM1IP2	PWM1IP1	PWM1IP0	—	—	—	—	—	—
IPC24	0870	—	PWM6IP2	PWM6IP1	PWM6IP0	—	PWM5IP2	PWM5IP1	PWM5IP0	—	PWM4IP2	PWM4IP1	PWM4IP0	—	PWM3
IPC35	0886	—	JTAGIP2	JTAGIP1	JTAGIP0	—	ICDIP2	ICDIP1	ICDIP0	—	—	—	—	—	—
IPC36	0888	—	PTG0IP2	PTG0IP1	PTG0IP0	—	PTGWDTIP2	PTGWDTIP1	PTGWDTIP0	—	PTGSTERIP2	PTGSTERIP1	PTGSTERIP0	—	PTG1
IPC37	088A	—	—	—	—	—	PTG3IP2	PTG3IP1	PTG3IP0	—	PTG2IP2	PTG2IP1	PTG2IP0	—	—
INTTREG	08C8	—	—	—	—	ILR3	ILR2	ILR1	ILR0	VECNUM7	VECNUM6	VECNUM5	VECNUM4	VECNUM3	VECNUM2

Legend: — = unimplemented, read as '0'. Reset values are shown in hexadecimal.

Note 1: The PMPIF/PMPIE/PMPIPx flags are not available on 44-pin devices.

2: The RTCCIF/RTCCIE/RTCCIPx flags are not available on 44-pin devices.

TABLE 4-4: TIMERS REGISTER MAP

SFR Name	Addr.	Bit 15	Bit 14	Bit 13	Bit 12	Bit 11	Bit 10	Bit 9	Bit 8	Bit 7	Bit 6	Bit 5	Bit 4	Bit 3	Bit 2	
TMR1	0100	Timer1 Register														
PR1	0102	Period Register 1														
T1CON	0104	TON	---	TSIDL	---	---	---	---	---	---	TGATE	TCKPS1	TCKPS0	---	TSYNC	
TMR2	0106	Timer2 Register														
TMR3HLD	0108	Timer3 Holding Register (For 32-bit timer operations only)														
TMR3	010A	Timer3 Register														
PR2	010C	Period Register 2														
PR3	010E	Period Register 3														
T2CON	0110	TON	---	TSIDL	---	---	---	---	---	---	TGATE	TCKPS1	TCKPS0	T32	---	
T3CON	0112	TON	---	TSIDL	---	---	---	---	---	---	TGATE	TCKPS1	TCKPS0	---	---	
TMR4	0114	Timer4 Register														
TMR5HLD	0116	Timer5 Holding Register (For 32-bit timer operations only)														
TMR5	0118	Timer5 Register														
PR4	011A	Period Register 4														
PR5	011C	Period Register 5														
T4CON	011E	TON	---	TSIDL	---	---	---	---	---	---	TGATE	TCKPS1	TCKPS0	T32	---	
T5CON	0120	TON	---	TSIDL	---	---	---	---	---	---	TGATE	TCKPS1	TCKPS0	---	---	
TMR6	0122	Timer6 Register														
TMR7HLD	0124	Timer7 Holding Register (For 32-bit timer operations only)														
TMR7	0126	Timer7 Register														
PR6	0128	Period Register 6														
PR7	012A	Period Register 7														
T6CON	012C	TON	---	TSIDL	---	---	---	---	---	---	TGATE	TCKPS1	TCKPS0	T32	---	
T7CON	012E	TON	---	TSIDL	---	---	---	---	---	---	TGATE	TCKPS1	TCKPS0	---	---	
TMR8	0130	Timer8 Register														
TMR9HLD	0132	Timer9 Holding Register (For 32-bit timer operations only)														
TMR9	0134	Timer9 Register														
PR8	0136	Period Register 8														
PR9	0138	Period Register 9														
T8CON	013A	TON	---	TSIDL	---	---	---	---	---	---	TGATE	TCKPS1	TCKPS0	T32	---	
T9CON	013C	TON	---	TSIDL	---	---	---	---	---	---	TGATE	TCKPS1	TCKPS0	---	---	

Legend: x = unknown value on Reset; --- = unimplemented, read as '0'. Reset values are shown in hexadecimal.

TABLE 4-5: INPUT CAPTURE 1 THROUGH INPUT CAPTURE 8 REGISTER MAP

SFR Name	Addr.	Bit 15	Bit 14	Bit 13	Bit 12	Bit 11	Bit 10	Bit 9	Bit 8	Bit 7	Bit 6	Bit 5	Bit 4	Bit 3	Bit 2
IC1CON1	0140	—	—	ICSIDL	ICTSEL2	ICTSEL1	ICTSEL0	—	—	—	IC11	IC10	ICOV	ICBNE	ICM2
IC1CON2	0142	—	—	—	—	—	—	—	IC32	ICTRIG	TRIGSTAT	—	SYNCSEL4	SYNCSEL3	SYNCSEL2
IC1BUF	0144	Input Capture 1 Buffer Register													
IC1TMR	0146	Input Capture 1 Timer Register													
IC2CON1	0148	—	—	ICSIDL	ICTSEL2	ICTSEL1	ICTSEL0	—	—	—	IC11	IC10	ICOV	ICBNE	ICM2
IC2CON2	014A	—	—	—	—	—	—	—	IC32	ICTRIG	TRIGSTAT	—	SYNCSEL4	SYNCSEL3	SYNCSEL2
IC2BUF	014C	Input Capture 2 Buffer Register													
IC2TMR	014E	Input Capture 2 Timer Register													
IC3CON1	0150	—	—	ICSIDL	ICTSEL2	ICTSEL1	ICTSEL0	—	—	—	IC11	IC10	ICOV	ICBNE	ICM2
IC3CON2	0152	—	—	—	—	—	—	—	IC32	ICTRIG	TRIGSTAT	—	SYNCSEL4	SYNCSEL3	SYNCSEL2
IC3BUF	0154	Input Capture 3 Buffer Register													
IC3TMR	0156	Input Capture 3 Timer Register													
IC4CON1	0158	—	—	ICSIDL	ICTSEL2	ICTSEL1	ICTSEL0	—	—	—	IC11	IC10	ICOV	ICBNE	ICM2
IC4CON2	015A	—	—	—	—	—	—	—	IC32	ICTRIG	TRIGSTAT	—	SYNCSEL4	SYNCSEL3	SYNCSEL2
IC4BUF	015C	Input Capture 4 Buffer Register													
IC4TMR	015E	Input Capture 4 Timer Register													
IC5CON1	0160	—	—	ICSIDL	ICTSEL2	ICTSEL1	ICTSEL0	—	—	—	IC11	IC10	ICOV	ICBNE	ICM2
IC5CON2	0162	—	—	—	—	—	—	—	IC32	ICTRIG	TRIGSTAT	—	SYNCSEL4	SYNCSEL3	SYNCSEL2
IC5BUF	0164	Input Capture 5 Buffer Register													
IC5TMR	0166	Input Capture 5 Timer Register													
IC6CON1	0168	—	—	ICSIDL	ICTSEL2	ICTSEL1	ICTSEL0	—	—	—	IC11	IC10	ICOV	ICBNE	ICM2
IC6CON2	016A	—	—	—	—	—	—	—	IC32	ICTRIG	TRIGSTAT	—	SYNCSEL4	SYNCSEL3	SYNCSEL2
IC6BUF	016C	Input Capture 6 Buffer Register													
IC6TMR	016E	Input Capture 6 Timer Register													
IC7CON1	0170	—	—	ICSIDL	ICTSEL2	ICTSEL1	ICTSEL0	—	—	—	IC11	IC10	ICOV	ICBNE	ICM2
IC7CON2	0172	—	—	—	—	—	—	—	IC32	ICTRIG	TRIGSTAT	—	SYNCSEL4	SYNCSEL3	SYNCSEL2
IC7BUF	0174	Input Capture 7 Buffer Register													
IC7TMR	0176	Input Capture 7 Timer Register													
IC8CON1	0178	—	—	ICSIDL	ICTSEL2	ICTSEL1	ICTSEL0	—	—	—	IC11	IC10	ICOV	ICBNE	ICM2
IC8CON2	017A	—	—	—	—	—	—	—	IC32	ICTRIG	TRIGSTAT	—	SYNCSEL4	SYNCSEL3	SYNCSEL2
IC8BUF	017C	Input Capture 8 Buffer Register													
IC8TMR	017E	Input Capture 8 Timer Register													

Legend: x = unknown value on Reset; — = unimplemented, read as '0'. Reset values are shown in hexadecimal.

TABLE 4-6: OUTPUT COMPARE REGISTER MAP

SFR Name	Addr.	Bit 15	Bit 14	Bit 13	Bit 12	Bit 11	Bit 10	Bit 9	Bit 8	Bit 7	Bit 6	Bit 5	Bit 4	Bit 3	Bit 2
OC1CON1	0900	—	—	OCSIDL	OCTSEL2	OCTSEL1	OCTSEL0	—	ENFLTB	ENFLTA	—	OCFLTB	OCFLTA	TRIGMODE	OCM2
OC1CON2	0902	FLTMD	FLTOUT	FLTTRIEI	OCINV	—	—	—	OC32	OC2TRIG	TRIGSTAT	OC2TRIS	SYNCSEL4	SYNCSEL3	SYNCSEL2
OC1RS	0904	Output Compare 1 Secondary Register													
OC1R	0906	Output Compare 1 Register													
OC1TMR	0908	Output Compare 1 Timer Value Register													
OC2CON1	090A	—	—	OCSIDL	OCTSEL2	OCTSEL1	OCTSEL0	—	ENFLTB	ENFLTA	—	OCFLTB	OCFLTA	TRIGMODE	OCM2
OC2CON2	090C	FLTMD	FLTOUT	FLTTRIEI	OCINV	—	—	—	OC32	OC2TRIG	TRIGSTAT	OC2TRIS	SYNCSEL4	SYNCSEL3	SYNCSEL2
OC2RS	090E	Output Compare 2 Secondary Register													
OC2R	0910	Output Compare 2 Register													
OC2TMR	0912	Output Compare 2 Timer Value Register													
OC3CON1	0914	—	—	OCSIDL	OCTSEL2	OCTSEL1	OCTSEL0	—	ENFLTB	ENFLTA	—	OCFLTB	OCFLTA	TRIGMODE	OCM2
OC3CON2	0916	FLTMD	FLTOUT	FLTTRIEI	OCINV	—	—	—	OC32	OC3TRIG	TRIGSTAT	OC3TRIS	SYNCSEL4	SYNCSEL3	SYNCSEL2
OC3RS	0918	Output Compare 3 Secondary Register													
OC3R	091A	Output Compare 3 Register													
OC3TMR	091C	Output Compare 3 Timer Value Register													
OC4CON1	091E	—	—	OCSIDL	OCTSEL2	OCTSEL1	OCTSEL0	—	ENFLTB	ENFLTA	—	OCFLTB	OCFLTA	TRIGMODE	OCM2
OC4CON2	0920	FLTMD	FLTOUT	FLTTRIEI	OCINV	—	—	—	OC32	OC4TRIG	TRIGSTAT	OC4TRIS	SYNCSEL4	SYNCSEL3	SYNCSEL2
OC4RS	0922	Output Compare 4 Secondary Register													
OC4R	0924	Output Compare 4 Register													
OC4TMR	0926	Output Compare 4 Timer Value Register													
OC5CON1	0928	—	—	OCSIDL	OCTSEL2	OCTSEL1	OCTSEL0	—	ENFLTB	ENFLTA	—	OCFLTB	OCFLTA	TRIGMODE	OCM2
OC5CON2	092A	FLTMD	FLTOUT	FLTTRIEI	OCINV	—	—	—	OC32	OC5TRIG	TRIGSTAT	OC5TRIS	SYNCSEL4	SYNCSEL3	SYNCSEL2
OC5RS	092C	Output Compare 5 Secondary Register													
OC5R	092E	Output Compare 5 Register													
OC5TMR	0930	Output Compare 5 Timer Value Register													
OC6CON1	0932	—	—	OCSIDL	OCTSEL2	OCTSEL1	OCTSEL0	—	ENFLTB	ENFLTA	—	OCFLTB	OCFLTA	TRIGMODE	OCM2
OC6CON2	0934	FLTMD	FLTOUT	FLTTRIEI	OCINV	—	—	—	OC32	OC6TRIG	TRIGSTAT	OC6TRIS	SYNCSEL4	SYNCSEL3	SYNCSEL2
OC6RS	0936	Output Compare 6 Secondary Register													
OC6R	0938	Output Compare 6 Register													
OC6TMR	093A	Output Compare 6 Timer Value Register													

Legend: x = unknown value on Reset; — = unimplemented; read as '0'. Reset values are shown in hexadecimal.

TABLE 4-6: OUTPUT COMPARE REGISTER MAP (CONTINUED)

SFR Name	Addr.	Bit 15	Bit 14	Bit 13	Bit 12	Bit 11	Bit 10	Bit 9	Bit 8	Bit 7	Bit 6	Bit 5	Bit 4	Bit 3	Bit 2
OC7CON1	093C	—	—	OCSIDL	OCTSEL2	OCTSEL1	OCTSEL0	—	ENFLTB	ENFLTA	—	OCFLTB	OCFLTA	TRIGMODE	OCM2
OC7CON2	093E	FLTMD	FLTOUT	FLTTRIEN	OCINV	—	—	—	OC32	OCTRIG	TRIGSTAT	OCTRIS	SYNCSEL4	SYNCSEL3	SYNCSEL2
OC7RS	0940	Output Compare 7 Secondary Register													
OC7R	0942	Output Compare 7 Register													
OC7TMR	0944	Output Compare 7 Timer Value Register													
OC8CON1	0946	—	—	OCSIDL	OCTSEL2	OCTSEL1	OCTSEL0	—	ENFLTB	ENFLTA	—	OCFLTB	OCFLTA	TRIGMODE	OCM2
OC8CON2	0948	FLTMD	FLTOUT	FLTTRIEN	OCINV	—	—	—	OC32	OCTRIG	TRIGSTAT	OCTRIS	SYNCSEL4	SYNCSEL3	SYNCSEL2
OC8RS	094A	Output Compare 8 Secondary Register													
OC8R	094C	Output Compare 8 Register													
OC8TMR	094E	Output Compare 8 Timer Value Register													

Legend: x = unknown value on Reset; — = unimplemented, read as '0'. Reset values are shown in hexadecimal.

TABLE 4-7: PTG REGISTER MAP

SFR Name	Addr.	Bit 15	Bit 14	Bit 13	Bit 12	Bit 11	Bit 10	Bit 9	Bit 8	Bit 7	Bit 6	Bit 5	Bit 4	Bit 3	Bit 2
PTGCST	0AC0	PTGEN	—	PTGSDIL	PTGTOGL	—	PTGSWT	PTGSSEN	PTGIVS	PTGSSTR	PTGWDTO	—	—	—	—
PTGCON	0AC2	PTGCLK2	PTGCLK1	PTGCLK0	PTGDIV4	PTGDIV3	PTGDIV2	PTGDIV1	PTGDIV0	PTGPWD3	PTGPWD2	PTGPWD1	PTGPWD0	—	PTGWDTO
PTGBTE	0AC4	ADCTS4	ADCTS3	ADCTS2	ADCTS1	IC4TSS	IC3TSS	IC2TSS	IC1TSS	OC4CS	OC3CS	OC2CS	OC1CS	OC4TSS	OC3TSS
PTGHOLD	0AC6	PTGHOLD<15:0>													
PTGTOLIM	0AC8	PTGTOLIM<15:0>													
PTGT1LIM	0ACA	PTGT1LIM<15:0>													
PTGSDLIM	0ACC	PTGSDLIM<15:0>													
PTGCOLIM	0ACE	PTGCOLIM<15:0>													
PTGC1LIM	0AD0	PTGC1LIM<15:0>													
PTGADJ	0AD2	PTGADJ<15:0>													
PTGLO	0AD4	PTGLO<15:0>													
PTGQPTR	0AD6	—	—	—	—	—	—	—	—	—	—	—	—	—	PTGQPTR
PTGQOE0	0AD8	STEP1<7:0>													
PTGQOE1	0ADA	STEP3<7:0>													
PTGQOE2	0ADC	STEP5<7:0>													
PTGQOE3	0ADE	STEP7<7:0>													
PTGQOE4	0AE0	STEP9<7:0>													
PTGQOE5	0AE2	STEP11<7:0>													
PTGQOE6	0AE4	STEP13<7:0>													
PTGQOE7	0AE6	STEP15<7:0>													
PTGQOE8	0xAE8	STEP17<7:0>													
PTGQOE9	0xAEA	STEP19<7:0>													
PTGQOE10	0xAEC	STEP21<7:0>													
PTGQOE11	0xAEE	STEP23<7:0>													
PTGQOE12	0xAF0	STEP25<7:0>													
PTGQOE13	0xAF2	STEP27<7:0>													
PTGQOE14	0xAF4	STEP29<7:0>													
PTGQOE15	0xAF6	STEP31<7:0>													
		STEP0<7:0>													
		STEP2<7:0>													
		STEP4<7:0>													
		STEP6<7:0>													
		STEP8<7:0>													
		STEP10<7:0>													
		STEP12<7:0>													
		STEP14<7:0>													
		STEP16<7:0>													
		STEP18<7:0>													
		STEP20<7:0>													
		STEP22<7:0>													
		STEP24<7:0>													
		STEP26<7:0>													
		STEP28<7:0>													
		STEP30<7:0>													

Legend: x = unknown value on Reset; — = unimplemented, read as '0'. Reset values are shown in hexadecimal.

TABLE 4-8: PWM REGISTER MAP

SFR Name	Addr.	Bit 15	Bit 14	Bit 13	Bit 12	Bit 11	Bit 10	Bit 9	Bit 8	Bit 7	Bit 6	Bit 5	Bit 4	Bit 3	Bit 2
PTCON	0C00	PTEN	—	PTSIDL	SESTAT	SEIEN	EIPU	SYNCPOL	SYNCOEN	SYNGEN	SYNCSRC2	SYNCSRC1	SYNCSRC0	SEVTPS3	SEVTPS2
PTCON2	0C02	—	—	—	—	—	—	—	—	—	—	—	—	—	P
PTPER	0C04	—	—	—	—	—	—	—	—	PTPER<15:0>					
SEVTCMP	0C06	—	—	—	—	—	—	—	—	SEVTCMP<15:0>					
MDC	0C0A	—	—	—	—	—	—	—	—	MDC<15:0>					
STCON	0C0E	—	—	—	SESTAT	SEIEN	EIPU	SYNCPOL	SYNCOEN	SYNGEN	SYNCSRC2	SYNCSRC1	SYNCSRC0	SEVTPS3	SEVTPS2
STCON2	0C10	—	—	—	—	—	—	—	—	—	—	—	—	—	P
STPER	0C12	—	—	—	—	—	—	—	—	STPER<15:0>					
SSEVTCMP	0C14	—	—	—	—	—	—	—	—	SSEVTCMP<15:0>					
CHOP	0C1A	CHPCLKEN	—	—	—	—	—	CHOPCLK9	CHOPCLK8	CHOPCLK7	CHOPCLK6	CHOPCLK5	CHOPCLK4	CHOPCLK3	CHOPCLK2
PWMKEY	0C1E	—	—	—	—	—	—	—	—	PWMKEY<15:0>					

Legend: — = unimplemented, read as '0'. Reset values are shown in hexadecimal.

TABLE 4-9: PWM GENERATOR 1 REGISTER MAP

SFR Name	Addr.	Bit 15	Bit 14	Bit 13	Bit 12	Bit 11	Bit 10	Bit 9	Bit 8	Bit 7	Bit 6	Bit 5	Bit 4	Bit 3	Bit 2
PWMCON1	0C20	FLTSTAT	CLSTAT	TRGSTAT	FLTEN	CLIEN	TRGIEN	ITB	MDCS	DTC1	DTC0	DTCP	—	MTBS	CAM
IOCON1	0C22	PENH	PENL	POLH	POLL	PMOD1	PMOD0	OVRENH	OVRENL	OVRDAT1	OVRDAT0	FLTDAT1	FLTDAT0	CLDAT1	CLDAT0
FCLCON1	0C24	IFLTMOD	CLSRC4	CLSRC3	CLSRC2	CLSRC1	CLSRC0	CLPOL	CLMOD	FLTSRC4	FLTSRC3	FLTSRC2	FLTSRC1	FLTSRC0	FLTPO
PDC1	0C26	—	—	—	—	—	—	—	—	PDC1<15:0>					
PHASE1	0C28	—	—	—	—	—	—	—	—	PHASE1<15:0>					
DTR1	0C2A	—	—	—	—	—	—	—	—	DTR1<13:0>					
ALTDTR1	0C2C	—	—	—	—	—	—	—	—	ALTDTR1<13:0>					
SDC1	0C2E	—	—	—	—	—	—	—	—	SDC1<15:0>					
SPHASE1	0C30	—	—	—	—	—	—	—	—	SPHASE1<15:0>					
TRIG1	0C32	—	—	—	—	—	—	—	—	TRGCMPI<15:0>					
TRGCON1	0C34	TRGDIV3	TRGDIV2	TRGDIV1	TRGDIV0	—	—	—	—	—	—	TRGSTRT5	TRGSTRT4	TRGSTRT3	TRGSTRT2
PWMCAP1	0C38	—	—	—	—	—	—	—	—	PWMCAP1<15:0>					
LEBCON1	0C3A	PHR	PHF	PLR	PLF	FLTLBEN	CLLEBEN	—	—	—	—	BCH	BCL	BPHH	BPHL
LEBDLY1	0C3C	—	—	—	—	—	—	—	—	LEB<11:0>					
AUXCON1	0C3E	—	—	—	—	BLANKSEL3	BLANKSEL2	BLANKSEL1	BLANKSEL0	—	—	CHOPSEL3	CHOPSEL2	CHOPSEL1	CHOPSEL0

Legend: — = unimplemented, read as '0'. Reset values are shown in hexadecimal.

TABLE 4-10: PWM GENERATOR 2 REGISTER MAP

SFR Name	Addr.	Bit 15	Bit 14	Bit 13	Bit 12	Bit 11	Bit 10	Bit 9	Bit 8	Bit 7	Bit 6	Bit 5	Bit 4	Bit 3	Bit 2
PWMCON2	0C40	FLTSTAT	CLSTAT	TRGSTAT	FLTIEN	CLIEN	TRGIEN	ITB	MDCS	DTC1	DTC0	DTCP	—	MTBS	CAM
IOCON2	0C42	PENH	PENL	POLH	POLL	PMOD1	PMOD0	OVRRENH	OVRRENL	OVRDAT1	OVRDAT0	FLTDAT1	FLTDAT0	CLDAT1	CLDAT0
FCLCON2	0C44	IFLTMOD	CLSRC4	CLSRC3	CLSRC2	CLSRC1	CLSRC0	CLPOL	CLMOD	FLTSRC4	FLTSRC3	FLTSRC2	FLTSRC1	FLTSRC0	FLTPO
PDC2	0C46	PDC2<15:0>													
PHASE2	0C48	PHASE2<15:0>													
DTR2	0C4A	DTR2<13:0>													
ALTDTR2	0C4C	ALTDTR2<13:0>													
SDC2	0C4E	SDC2<15:0>													
SPHASE2	0C50	SPHASE2<15:0>													
TRIG2	0C52	TRGCMPL<15:0>													
TRGCON2	0C54	TRGDIV3	TRGDIV2	TRGDIV1	TRGDIV0	—	—	—	—	—	—	TRGSTRT5	TRGSTRT4	TRGSTRT3	TRGSTRT2
PWMCAP2	0C78	PWMCAP2<15:0>													
LEBCON2	0C5A	PHR	PHF	PLR	PLF	FLTLBEN	CLLBEN	—	—	—	—	BCH	BCL	BPHH	BPHL
LEBDLY2	0C5C	—	—	—	—	—	—	—	—	—	—	—	—	—	—
AUXCON2	0C5E	—	—	—	—	BLANKSEL3	BLANKSEL2	BLANKSEL1	BLANKSEL0	—	—	CHOPSEL3	CHOPSEL2	CHOPSEL1	CHOPSEL0

Legend: — = unimplemented, read as '0'. Reset values are shown in hexadecimal.

TABLE 4-11: PWM GENERATOR 3 REGISTER MAP

SFR Name	Addr.	Bit 15	Bit 14	Bit 13	Bit 12	Bit 11	Bit 10	Bit 9	Bit 8	Bit 7	Bit 6	Bit 5	Bit 4	Bit 3	Bit 2
PWMCON3	0C60	FLTSTAT	CLSTAT	TRGSTAT	FLTIEN	CLIEN	TRGIEN	ITB	MDCS	DTC1	DTC0	DTCP	—	MTBS	CAM
IOCON3	0C62	PENH	PENL	POLH	POLL	PMOD1	PMOD0	OVRRENH	OVRRENL	OVRDAT1	OVRDAT0	FLTDAT1	FLTDAT0	CLDAT1	CLDAT0
FCLCON3	0C64	IFLTMOD	CLSRC4	CLSRC3	CLSRC2	CLSRC1	CLSRC0	CLPOL	CLMOD	FLTSRC4	FLTSRC3	FLTSRC2	FLTSRC1	FLTSRC0	FLTPO
PDC3	0C66	PDC3<15:0>													
PHASE3	0C68	PHASE3<15:0>													
DTR3	0C6A	DTR3<13:0>													
ALTDTR3	0C6C	ALTDTR3<13:0>													
SDC3	0C6E	SDC3<15:0>													
SPHASE3	0C70	SPHASE3<15:0>													
TRIG3	0C72	TRGCMPL<15:0>													
TRGCON3	0C74	TRGDIV3	TRGDIV2	TRGDIV1	TRGDIV0	—	—	—	—	—	—	TRGSTRT5	TRGSTRT4	TRGSTRT3	TRGSTRT2
PWMCAP3	0C78	PWMCAP3<15:0>													
LEBCON3	0C7A	PHR	PHF	PLR	PLF	FLTLBEN	CLLBEN	—	—	—	—	BCH	BCL	BPHH	BPHL
LEBDLY3	0C7C	—	—	—	—	—	—	—	—	—	—	—	—	—	—
AUXCON3	0C7E	—	—	—	—	BLANKSEL3	BLANKSEL2	BLANKSEL1	BLANKSEL0	—	—	CHOPSEL3	CHOPSEL2	CHOPSEL1	CHOPSEL0

Legend: — = unimplemented, read as '0'. Reset values are shown in hexadecimal.

TABLE 4-12: PWM GENERATOR 4 REGISTER MAP

SFR Name	Addr.	Bit 15	Bit 14	Bit 13	Bit 12	Bit 11	Bit 10	Bit 9	Bit 8	Bit 7	Bit 6	Bit 5	Bit 4	Bit 3	Bit 2
PWMCON4	0C80	FLTSTAT	CLSTAT	TRGSTAT	FLTIEN	CLIEN	TRGIEN	ITB	MDCS	DTC1	DTC0	DTCP	—	MTBS	CAM
IOCON4	0C82	PENH	PENL	POLH	POLL	PMOD1	PMOD0	OVRENH	OVRENL	OVRDAT1	OVRDAT0	FLTDAT1	FLTDAT0	CLDAT1	CLDAT0
FOLCON4	0C84	IFLTMOD	CLSRC4	CLSRC3	CLSRC2	CLSRC1	CLSRC0	CLPOL	CLMOD	FLTSRC4	FLTSRC3	FLTSRC2	FLTSRC1	FLTSRC0	FLTPO
PDC4	0C86	PDC3<15:0>													
PHASE4	0C88	PHASE3<15:0>													
DTR4	0C8A	DTR3<13:0>													
ALTDTR4	0C8C	ALTDTR3<13:0>													
SDC4	0C8E	SDC4<15:0>													
SPHASE4	0C90	SPHASE4<15:0>													
TRIG4	0C92	TRGOMP<15:0>													
TRGCON4	0C94	TRGDIV3	TRGDIV2	TRGDIV1	TRGDIV0	—	—	—	—	—	—	TRGSTR15	TRGSTR14	TRGSTR13	TRGSTR
PWMCAP4	0C98	PWMCAP4<15:0>													
LEBCON4	0C9A	PHR	PHF	PLR	PLF	FLTLBEN	CLLBEN	—	—	—	—	BCH	BCL	BPHH	BPHL
LEBDLY4	0C9C	LEB<11:0>													
AUXCON4	0C9E	—	—	—	—	BLANKSEL3	BLANKSEL2	BLANKSEL1	BLANKSEL0	—	—	CHOPSEL3	CHOPSEL2	CHOPSEL1	CHOPSEL0

Legend: — = unimplemented, read as '0'. Reset values are shown in hexadecimal.

TABLE 4-13: PWM GENERATOR 5 REGISTER MAP

SFR Name	Addr.	Bit 15	Bit 14	Bit 13	Bit 12	Bit 11	Bit 10	Bit 9	Bit 8	Bit 7	Bit 6	Bit 5	Bit 4	Bit 3	Bit 2
PWMCON5	0CA0	FLTSTAT	CLSTAT	TRGSTAT	FLTIEN	CLIEN	TRGIEN	ITB	MDCS	DTC1	DTC0	DTCP	—	MTBS	CAM
IOCON5	0CA5	PENH	PENL	POLH	POLL	PMOD1	PMOD0	OVRENH	OVRENL	OVRDAT1	OVRDAT0	FLTDAT1	FLTDAT0	CLDAT1	CLDAT0
FOLCON5	0CA4	IFLTMOD	CLSRC4	CLSRC3	CLSRC2	CLSRC1	CLSRC0	CLPOL	CLMOD	FLTSRC4	FLTSRC3	FLTSRC2	FLTSRC1	FLTSRC0	FLTPO
PDC5	0CA6	PDC5<15:0>													
PHASE5	0CA8	PHASE5<15:0>													
DTR5	0CAA	DTR5<13:0>													
ALTDTR5	0CAC	ALTDTR5<13:0>													
SDC5	0CAE	SDC5<15:0>													
SPHASE5	0CB0	SPHASE5<15:0>													
TRIG5	0CB2	TRGOMP<15:0>													
TRGCON5	0CB4	TRGDIV3	TRGDIV2	TRGDIV1	TRGDIV0	—	—	—	—	—	—	TRGSTR15	TRGSTR14	TRGSTR13	TRGSTR12
PWMCAP5	0CB8	PWMCAP5<15:0>													
LEBCON5	0CBA	PHR	PHF	PLR	PLF	FLTLBEN	CLLBEN	—	—	—	—	BCH	BCL	BPHH	BPHL
LEBDLY5	0CBC	LEB<11:0>													
AUXCON5	0CBE	—	—	—	—	BLANKSEL3	BLANKSEL2	BLANKSEL1	BLANKSEL0	—	—	CHOPSEL3	CHOPSEL2	CHOPSEL1	CHOPSEL0

Legend: — = unimplemented, read as '0'. Reset values are shown in hexadecimal.

TABLE 4-14: PWM GENERATOR 6 REGISTER MAP

SFR Name	Addr.	Bit 15	Bit 14	Bit 13	Bit 12	Bit 11	Bit 10	Bit 9	Bit 8	Bit 7	Bit 6	Bit 5	Bit 4	Bit 3	Bit 2
PWMCON6	0CC0	FLTSTAT	CLSTAT	TRGSTAT	FLTREN	CLREN	TRGIEN	ITB	MDCS	DTC1	DTC0	DTCP	—	MTBS	CAM
IOCON6	0CC2	PENH	PENL	POLH	POLL	PMOD1	PMOD0	OVRENH	OVRENL	OVRDAT1	OVRDAT0	FLTDAT1	FLTDAT0	CLDAT1	CLDAT0
FOLCON6	0CC4	IFLTMOD	CLSRC4	CLSRC3	CLSRC2	CLSRC1	CLSRC0	CLPOL	CLMOD	FLTSRC4	FLTSRC3	FLTSRC2	FLTSRC1	FLTSRC0	FLTPOL
PDC6	0CC6	PDC6<15:0>													
PHASE6	0CC8	PHASE6<15:0>													
DTR6	0CCA	DTR6<13:0>													
ALDTR6	0CCC	ALDTR6<13:0>													
SDC6	0CCE	SDC6<15:0>													
SPHASE6	0CD0	SPHASE6<15:0>													
TRIG6	0CD2	TRIG6<15:0>													
TRGCON6	0CD4	TRGDIV3	TRGDIV2	TRGDIV1	TRGDIV0	—	—	—	—	—	—	TRGSTR15	TRGSTR14	TRGSTR13	TRGSTR12
PWMICAP6	0CD8	PWMICAP6<15:0>													
LEBCON6	0CDA	PHR	PHF	PLR	PLF	FLTLBEN	CLLBEN	—	—	—	—	BCH	BCL	BPHH	BPHL
LEBDLY6	0CDC	—	—	—	—	—	—	—	—	—	—	LEB<11:0>			
AUXCON6	0CDE	—	—	—	—	BLANKSEL3	BLANKSEL2	BLANKSEL1	BLANKSEL0	—	—	CHOPSEL3	CHOPSEL2	CHOPSEL1	CHOPSEL0

Legend: — = unimplemented, read as '0'. Reset values are shown in hexadecimal.

TABLE 4-15: QE1 REGISTER MAP

SFR Name	Addr:	Bit 15	Bit 14	Bit 13	Bit 12	Bit 11	Bit 10	Bit 9	Bit 8	Bit 7	Bit 6	Bit 5	Bit 4	Bit 3
QE1CON	01C0	QE1EN	—	QE1SIDL	PIMOD2	PIMOD1	PIMOD0	IMV1	IMV0	—	INTDIV2	INTDIV1	INTDIV0	CNTPOL
QE1IOC	01C2	QCAPEN	FLTREN	QFDIV2	QFDIV1	QFDIV0	OUTFNC1	OUTFNC0	SWPAB	HOMPOL	IDXPOL	QEBPOL	QEAPOL	HOME
QE1STAT	01C4	—	—	PCHEQ1RQ	PCHEQ1EN	PCLEQ1RQ	PCLEQ1EN	POSOV1RQ	POSOV1EN	PCI1RQ	PC11EN	VELOV1RQ	VELOV1EN	HOM1RQ
POS1CNTL	01C6	POSCNT<15:0>												
POS1CNTH	01C8	POSCNT<31:16>												
POS1HLD	01CA	POSHLD<15:0>												
VEL1CNT	01CC	VELCNT<15:0>												
INT1TMR	01CE	INTTMR<15:0>												
INT1TMRH	01D0	INTTMR<31:16>												
INT1HLDL	01D2	INTHLD<15:0>												
INT1HLDH	01D4	INTHLD<31:16>												
INDX1CNTL	01D6	INDXCNT<15:0>												
INDX1CNTH	01D8	INDXCNT<31:16>												
INDX1HLD	01DA	INDXHLD<15:0>												
QE1GEC	01DC	QE1GEC<15:0>												
QE1ICL	01DC	QE1IC<15:0>												
QE1GEC	01DE	QE1GEC<31:16>												
QE1ICH	01DE	QE1IC<31:16>												
QE1LECL	01E0	QE1LEC<15:0>												
QE1LECH	01E2	QE1LEC<31:16>												

Legend: x = unknown value on Reset; — = unimplemented, read as '0'. Reset values are shown in hexadecimal.

TABLE 4-16: QE12 REGISTER MAP

SFR Name	Addr.	Bit 15	Bit 14	Bit 13	Bit 12	Bit 11	Bit 10	Bit 9	Bit 8	Bit 7	Bit 6	Bit 5	Bit 4	Bit 3
QE12CON	05C0	QE1EN	—	QE1SIDL	P1MOD2	P1MOD1	P1MOD0	IMV1	IMV0	—	INTDIV2	INTDIV1	INTDIV0	CNTPOL
QE12IOC	05C2	QCAPEN	FLTREN	QFDIV2	QFDIV1	QFDIV0	OUTFNC1	OUTFNC0	SWPAB	HOMPOL	IDXPOL	QEBPOL	QEAPOL	HOME
QE12STAT	05C4	—	—	PCHEQ1RQ	PCHEQ1EN	PCLEQ1RQ	PCLEQ1EN	POSOV1RQ	POSOV1EN	PC1IRQ	PC1IEN	VELOV1RQ	VELOV1EN	HOM1RQ
POS2CNTL	05C6	POSCNT<15:0>												
POS2CNTH	05C8	POSCNT<31:16>												
POS2HLD	05CA	POSHLD<15:0>												
VEL2CNT	05CC	VELCNT<15:0>												
INT2TMR	05CE	INTTMR<15:0>												
INT2TMRH	05D0	INTTMR<31:16>												
INT2HLDL	05D2	INTHLD<15:0>												
INT2HLDH	05D4	INTHLD<31:16>												
INDX2CNTL	05D6	INDXCNT<15:0>												
INDX2CNTH	05D8	INDXCNT<31:16>												
INDX2HLD	05DA	INDXHLD<15:0>												
QE12GECL	05DC	QE1GEC<15:0>												
QE12ICL	05DE	QE1IC<15:0>												
QE12GECH	05DE	QE1GEC<31:16>												
QE12ICH	05DE	QE1IC<31:16>												
QE12LECL	05E0	QE1LEC<15:0>												
QE12LECH	05E2	QE1LEC<31:16>												

Legend: x = unknown value on Reset; — = unimplemented, read as '0'. Reset values are shown in hexadecimal.

TABLE 4-17: I2C1 AND I2C2 REGISTER MAP

SFR Name	Addr.	Bit 15	Bit 14	Bit 13	Bit 12	Bit 11	Bit 10	Bit 9	Bit 8	Bit 7	Bit 6	Bit 5	Bit 4	Bit 3	Bit 2
I2C1RCV	0200	—	—	—	—	—	—	—	—	—	—	—	—	—	—
I2C1TRN	0202	—	—	—	—	—	—	—	—	—	—	—	—	—	—
I2C1BRG	0204	Baud Rate Generator Register													
I2C1CON	0206	I2CEN	—	I2CSIDL	SCLREL	IPMIEN	A10M	DISSLW	SMEN	GCEN	STREN	ACKDT	ACKEN	RCEN	PEN
I2C1STAT	0208	ACKSTAT	TRSTAT	—	—	—	BCL	GCSTAT	ADD10	IWCOL	I2COV	D_A	P	S	R_W
I2C1ADD	020A	—	—	—	—	—	—	I2C1 Address Register							
I2C1MSK	020C	—	—	—	—	—	—	I2C1 Address Mask Register							
I2C2RCV	0210	—	—	—	—	—	—	—	—	—	—	—	—	—	—
I2C2TRN	0212	—	—	—	—	—	—	—	—	—	—	—	—	—	—
I2C2BRG	0214	Baud Rate Generator Register													
I2C2CON	0216	I2CEN	—	I2CSIDL	SCLREL	IPMIEN	A10M	DISSLW	SMEN	GCEN	STREN	ACKDT	ACKEN	RCEN	PEN
I2C2STAT	0218	ACKSTAT	TRSTAT	—	—	—	BCL	GCSTAT	ADD10	IWCOL	I2COV	D_A	P	S	R_W
I2C2ADD	021A	—	—	—	—	—	—	I2C2 Address Register							
I2C2MSK	021C	—	—	—	—	—	—	I2C2 Address Mask Register							

Legend: — = unimplemented, read as '0'. Reset values are shown in hexadecimal.

TABLE 4-18: UART1 AND UART2 REGISTER MAP

SFR Name	Addr.	Bit 15	Bit 14	Bit 13	Bit 12	Bit 11	Bit 10	Bit 9	Bit 8	Bit 7	Bit 6	Bit 5	Bit 4	Bit 3	Bit 2
U1MODE	0220	UARTEN	—	—	—	—	—	—	—	—	—	—	—	—	—
U1STA	0222	UTXISEL1	UTXINV	USIDL	IREN	RTSMD	UTXEN	UTXBF	UEN0	WAKE	LPBACK	ABAUD	URXINV	BRGH	PSEL
U1TXREG	0224	—	—	—	—	—	—	—	—	—	—	—	—	—	FERR
U1RXREG	0226	—	—	—	—	—	—	—	—	—	—	—	—	—	FERR
U1BRG	0228	Baud Rate Generator Prescaler													
U2MODE	0230	UARTEN	—	USIDL	IREN	RTSMD	UTXEN	UTXBF	UEN0	WAKE	LPBACK	ABAUD	URXINV	BRGH	PSEL
U2STA	0232	UTXISEL1	UTXINV	UTXISEL0	—	—	—	—	—	—	—	—	—	—	FERR
U2TXREG	0234	—	—	—	—	—	—	—	—	—	—	—	—	—	FERR
U2RXREG	0236	—	—	—	—	—	—	—	—	—	—	—	—	—	FERR
U2BRG	0238	Baud Rate Generator Prescaler													

Legend: x = unknown value on Reset; — = unimplemented, read as '0'. Reset values are shown in hexadecimal.

TABLE 4-19: UART3 AND UART4 REGISTER MAP

SFR Name	Addr.	Bit 15	Bit 14	Bit 13	Bit 12	Bit 11	Bit 10	Bit 9	Bit 8	Bit 7	Bit 6	Bit 5	Bit 4	Bit 3	Bit 2
U3MODE	0250	UARTEN	—	USIDL	IREN	RTSMO	—	UEN1	UENO	WAKE	LPBACK	ABAUD	URXINV	BRGH	PDSE
U3STA	0252	UTXISEL1	UTXINV	UTXISEL0	—	UTXBRK	UTXEN	UTXBF	TRMT	URXISEL1	URXISEL0	ADDEN	RIDLE	PERR	FERR
U3TXREG	0254	—	—	—	—	—	—	—	—	—	—	—	—	—	—
U3RXREG	0256	—	—	—	—	—	—	—	—	—	—	—	—	—	—
U3BRG	0258	Baud Rate Generator Prescaler													
U4MODE	02B0	UARTEN	—	USIDL	IREN	RTSMO	—	UEN1	UENO	WAKE	LPBACK	ABAUD	URXINV	BRGH	PDSE
U4STA	02B2	UTXISEL1	UTXINV	UTXISEL0	—	UTXBRK	UTXEN	UTXBF	TRMT	URXISEL1	URXISEL0	ADDEN	RIDLE	PERR	FERR
U4TXREG	02B4	—	—	—	—	—	—	—	—	—	—	—	—	—	—
U4RXREG	02B6	—	—	—	—	—	—	—	—	—	—	—	—	—	—
U4BRG	02B8	Baud Rate Generator Prescaler													

Legend: x = unknown value on Reset; — = unimplemented, read as '0'. Reset values are shown in hexadecimal.

TABLE 4-20: SPI1, SPI2 AND SPI3 REGISTER MAP

SFR Name	Addr.	Bit 15	Bit 14	Bit 13	Bit 12	Bit 11	Bit 10	Bit 9	Bit 8	Bit 7	Bit 6	Bit 5	Bit 4	Bit 3	Bit 2
SPI1STAT	0240	SPIEN	—	SPIIDL	—	—	SPIBEC2	SPIBEC1	SPIBEC0	SRMPT	SPIROV	SRXMPT	SISEL2	SISEL1	SISEL0
SPI1CON1	0242	—	—	—	DISSCK	DISSDO	MODE16	SMP	CKE	SSEN	CKP	MSTEN	SPRE2	SPRE1	SPRE0
SPI1CON2	0244	FRMEN	SPIFSD	FRMPOL	—	—	—	—	—	—	—	—	—	—	—
SPI1BUF	0248	SPI1 Transmit and Receive Buffer Register													
SPI2STAT	0260	SPIEN	—	SPIIDL	—	—	SPIBEC2	SPIBEC1	SPIBEC0	SRMPT	SPIROV	SRXMPT	SISEL2	SISEL1	SISEL0
SPI2CON1	0262	—	—	—	DISSCK	DISSDO	MODE16	SMP	CKE	SSEN	CKP	MSTEN	SPRE2	SPRE1	SPRE0
SPI2CON2	0264	FRMEN	SPIFSD	FRMPOL	—	—	—	—	—	—	—	—	—	—	—
SPI2BUF	0268	SPI2 Transmit and Receive Buffer Register													
SPI3STAT	02A0	SPIEN	—	SPIIDL	—	—	SPIBEC2	SPIBEC1	SPIBEC0	SRMPT	SPIROV	SRXMPT	SISEL2	SISEL1	SISEL0
SPI3CON1	02A2	—	—	—	DISSCK	DISSDO	MODE16	SMP	CKE	SSEN	CKP	MSTEN	SPRE2	SPRE1	SPRE0
SPI3CON2	02A4	FRMEN	SPIFSD	FRMPOL	—	—	—	—	—	—	—	—	—	—	—
SPI3BUF	02A8	SPI3 Transmit and Receive Buffer Register													

Legend: — = unimplemented, read as '0'. Reset values are shown in hexadecimal.

TABLE 4-21: DCI REGISTER MAP

SFR Name	Addr.	Bit 15	Bit 14	Bit 13	Bit 12	Bit 11	Bit 10	Bit 9	Bit 8	Bit 7	Bit 6	Bit 5	Bit 4	Bit 3	Bit 2
DCICON1	0280	DCIEN	r	DCISIDL	r	DLOOP	CCKD	CCKE	COFSD	UNFM	CSDOM	DJUST	r	r	r
DCICON2	0282	r	r	r	r	BLEN1	BLEN0	r	COFSG3	COFSG2	COFSG1	COFSG0	r	WS3	WS2
DCICON3	0284	r	r	r	r										
DCISTAT	0286	r	r	r	r	SLOT3	SLOT2	SLOT1	SLOT0	r	r	r	r	ROV	RFUL
TSCON	0288	TSE<15:0>													
RSCON	028C	RSE<15:0>													
RXBUF0	0290	Receive 0 Data Register													
RXBUF1	0292	Receive 1 Data Register													
RXBUF2	0294	Receive 2 Data Register													
RXBUF3	0296	Receive 3 Data Register													
TXBUF0	0298	Transmit 0 Data Register													
TXBUF1	029A	Transmit 1 Data Register													
TXBUF2	029C	Transmit 2 Data Register													
TXBUF3	029E	Transmit 3 Data Register													

Legend: u = unchanged; r = reserved; — = unimplemented, read as '0'. Reset values are shown in hexadecimal.

TABLE 4-22: ADC1 AND ADC2 REGISTER MAP

SFR Name	Addr.	Bit 15	Bit 14	Bit 13	Bit 12	Bit 11	Bit 10	Bit 9	Bit 8	Bit 7	Bit 6	Bit 5	Bit 4	Bit 3	Bit 2
ADC1BUF0	0300	ADC1 Data Buffer 0													
ADC1BUF1	0302	ADC1 Data Buffer 1													
ADC1BUF2	0304	ADC1 Data Buffer 2													
ADC1BUF3	0306	ADC1 Data Buffer 3													
ADC1BUF4	0308	ADC1 Data Buffer 4													
ADC1BUF5	030A	ADC1 Data Buffer 5													
ADC1BUF6	030C	ADC1 Data Buffer 6													
ADC1BUF7	030E	ADC1 Data Buffer 7													
ADC1BUF8	0310	ADC1 Data Buffer 8													
ADC1BUF9	0312	ADC1 Data Buffer 9													
ADC1BUFA	0314	ADC1 Data Buffer 10													
ADC1BUFB	0316	ADC1 Data Buffer 11													
ADC1BUFC	0318	ADC1 Data Buffer 12													
ADC1BUFD	031A	ADC1 Data Buffer 13													
ADC1BUFE	031C	ADC1 Data Buffer 14													
ADC1BUFF	031E	ADC1 Data Buffer 15													
AD1CON1	0320	ADON	—	ADSIDL	ADDMABM	—	AD12B	FORM1	FORM0	SSRC2	SSRC1	SSRC0	SSRCG	SIMSAM	ASAM
AD1CON2	0322	VCFG2	VCFG1	VCFG0	OFFCAL	—	CSCNA	CHPS1	CHPS0	BUFS	SMP14	SMP13	SMP12	SMP11	SMP10
AD1CON3	0324	ADRC	—	—	SAMC4	SAMC3	SAMC2	SAMC1	SAMC0	ADCS7	ADCS6	ADCS5	ADCS4	ADCS3	ADCS2
AD1CHS123	0326	—	—	—	CH123SB2	CH123SB1	CH123NB1	CH123NB0	CH123SB0	—	—	—	CH123SA2	CH123SA1	CH123NA
AD1CHS0	0328	CH0NB	—	CH0SB5	CH0SB4	CH0SB3	CH0SB2	CH0SB1	CH0SB0	CH0NA	—	CH0SA5	CH0SA4	CH0SA3	CH0SA2
AD1CSSH	032E	CSS<31:16>													
AD1CSSL	0330	CSS<15:0>													
AD1CON4	0332	—	—	—	—	—	—	—	ADDMAEN	—	—	—	—	—	DMABL2
ADC2BUF0	0340	ADC2 Data Buffer 0													
ADC2BUF1	0342	ADC2 Data Buffer 1													
ADC2BUF2	0344	ADC2 Data Buffer 2													
ADC2BUF3	0346	ADC2 Data Buffer 3													
ADC2BUF4	0348	ADC2 Data Buffer 4													
ADC2BUF5	034A	ADC2 Data Buffer 5													
ADC2BUF6	034C	ADC2 Data Buffer 6													
ADC2BUF7	034E	ADC2 Data Buffer 7													
ADC2BUF8	0350	ADC2 Data Buffer 8													

Legend: x = unknown value on Reset; — = unimplemented, read as '0'. Reset values are shown in hexadecimal.

Note 1: Bits 13 and bit 5 are reserved in the AD2CHS0 register, unlike the AD1CHS0 register.

TABLE 4-22: ADC1 AND ADC2 REGISTER MAP (CONTINUED)

SFR Name	Addr.	Bit 15	Bit 14	Bit 13	Bit 12	Bit 11	Bit 10	Bit 9	Bit 8	Bit 7	Bit 6	Bit 5	Bit 4	Bit 3	Bit 2
ADC2BUF9	0352	ADC2 Data Buffer 9													
ADC2BUFA	0354	ADC2 Data Buffer 10													
ADC2BUFB	0356	ADC2 Data Buffer 11													
ADC2BUFC	0358	ADC2 Data Buffer 12													
ADC2BUFD	035A	ADC2 Data Buffer 13													
ADC2BUFE	035C	ADC2 Data Buffer 14													
ADC2BUFF	035E	ADC2 Data Buffer 15													
AD2CON1	0360	ADON	—	ADSIDL	ADDMABM	—	AD12B	FORM1	FORM0	SSRC2	SSRC1	SSRC0	SSRCG	SIMSAM	ASAM
AD2CON2	0362	VCFG2	VCFG1	VCFG0	OFFCAL	—	CSCNA	CHPS1	CHPS0	BUFS	SMP14	SMP13	SMP12	SMP11	SMP10
AD2CON3	0364	ADRC	—	—	SAMC4	SAMC3	SAMC2	SAMC1	SAMC0	ADCS7	ADCS6	ADCS5	ADCS4	ADCS3	ADCS2
AD2CHS123	0366	—	—	—	CH123SB2	CH123SB1	CH123NB1	CH123NB0	CH123SB0	—	—	—	CH123SA2	CH123SA1	CH123NA
AD2CHS0	0368	CH0NB	—	CH0SB5 ⁽¹⁾	CH0SB4	CH0SB3	CH0SB2	CH0SB1	CH0SB0	CH0NA	—	CH0SA5 ⁽¹⁾	CH0SA4	CH0SA3	CH0SA2
AD2CSSH	036E	CSS<31:16>													
AD2CSSL	0370	CSS<15:0>													
AD2CON4	0372	—	—	—	—	—	—	—	ADDMAEN	—	—	—	—	—	DMABL2

Legend: x = unknown value on Reset; — = unimplemented, read as '0'. Reset values are shown in hexadecimal.

Note 1: Bits 13 and bit 5 are reserved in the AD2CHS0 register, unlike the AD1CHS0 register.

TABLE 4-23: CAN1 REGISTER MAP WHEN WIN (C1CTRL<0>) = 0 OR 1 FOR dsPIC33EPXXXGM60X77XX DEVICES(1)

SFR Name	Addr.	Bit 15	Bit 14	Bit 13	Bit 12	Bit 11	Bit 10	Bit 9	Bit 8	Bit 7	Bit 6	Bit 5	Bit 4	Bit 3	Bit 2
C1CTRL1	0400	—	—	CSIDL	ABAT	CANCKS	REGOP2	REGOP1	REGOP0	OPMODE2	OPMODE1	OPMODE0	—	CANCAP	—
C1CTRL2	0402	—	—	—	—	—	—	—	—	—	—	—	—	—	DNCONT
C1VEC	0404	—	—	—	FILHIT4	FILHIT3	FILHIT2	FILHIT1	FILHIT0	—	ICODE6	ICODE5	ICODE4	ICODE3	ICODE1
C1FCTRL	0406	DMABS2	DMABS1	DMABS0	—	—	—	—	—	—	—	—	FSA4	FSA3	FSA2
C1FIFO	0408	—	—	FBP5	FBP4	FBP3	FBP2	FBP1	FBP0	—	—	FNRB5	FNRB4	FNRB3	FNRB2
C1INTF	040A	—	—	TXBO	TXBP	RXPB	TXWAR	RXPWAR	EWARN	IVRIF	WAKIF	ERRIF	—	FIFOIF	RBOVF
C1INTE	040C	—	—	—	—	—	—	—	—	IVRIE	WAKIE	ERRIE	—	FIFOIE	RBOVIE
C1IEC	040E	TERRCNT7	TERRCNT6	TERRCNT5	TERRCNT4	TERRCNT3	TERRCNT2	TERRCNT1	TERRCNT0	RERRCNT7	RERRCNT6	RERRCNT5	RERRCNT4	RERRCNT3	RERRCNT2
C1CFG1	0410	—	—	—	—	—	—	—	—	—	—	—	—	—	—
C1CFG2	0412	—	—	—	—	—	—	—	—	—	—	—	—	—	—
C1FEN1	0414	—	—	—	—	—	—	—	—	—	—	—	—	—	—
C1FMSKSEL1	0418	F7MSK1	F7MSK0	F6MSK1	F6MSK0	F5MSK1	F5MSK0	F4MSK1	F4MSK0	F3MSK1	F3MSK0	F2MSK1	F2MSK0	F1MSK1	F1MSK0
C1FMSKSEL2	041A	F15MSK1	F15MSK0	F14MSK1	F14MSK0	F13MSK1	F13MSK0	F12MSK1	F12MSK0	F11MSK1	F11MSK0	F10MSK1	F10MSK0	F9MSK1	F9MSK0

Legend: — = unimplemented, read as '0'. Reset values are shown in hexadecimal.

Note 1: These registers are not present on dsPIC33EPXXXGM3XX devices.

TABLE 4-24: CAN1 REGISTER MAP WHEN WIN (C1CTRL<0>) = 0 FOR dsPIC33EPXXXGM60X77XX DEVICES(1)

SFR Name	Addr.	Bit 15	Bit 14	Bit 13	Bit 12	Bit 11	Bit 10	Bit 9	Bit 8	Bit 7	Bit 6	Bit 5	Bit 4	Bit 3	Bit 2
C1RXFUL1	0400-041E	See definition when WIN = x													
C1RXFUL2	0420	RXFUL<15:0>													
C1RXOVF1	0422	RXFUL<31:16>													
C1RXOVF2	0428	RXOVF<15:0>													
C1TR01CON	0430	TXEN1	TXABT1	TXLARB1	TXERR1	TXREQ1	RTREN1	TX1PRI1	TX1PRI0	TXEN0	TXABAT0	TXLARB0	TXERR0	TXREQ0	RTREN0
C1TR23CON	0432	TXEN3	TXABT3	TXLARB3	TXERR3	TXREQ3	RTREN3	TX3PRI1	TX3PRI0	TXEN2	TXABAT2	TXLARB2	TXERR2	TXREQ2	RTREN2
C1TR45CON	0434	TXEN5	TXABT5	TXLARB5	TXERR5	TXREQ5	RTREN5	TX5PRI1	TX5PRI0	TXEN4	TXABAT4	TXLARB4	TXERR4	TXREQ4	RTREN4
C1TR67CON	0436	TXEN7	TXABT7	TXLARB7	TXERR7	TXREQ7	RTREN7	TX7PRI1	TX7PRI0	TXEN6	TXABAT6	TXLARB6	TXERR6	TXREQ6	RTREN6
C1RXD	0440	CAN1 Receive Data Word													
C1TXD	0442	CAN1 Transmit Data Word													

Legend: x = unknown value on Reset; — = unimplemented, read as '0'. Reset values are shown in hexadecimal.

Note 1: These registers are not present on dsPIC33EPXXXGM3XX devices.

TABLE 4-25: CAN1 REGISTER MAP WHEN WIN (C1CTRL<0>) = 1 FOR dsPIC33EPXXGM60X/7XX DEVICES⁽¹⁾

SFR Name	Addr.	Bit 15	Bit 14	Bit 13	Bit 12	Bit 11	Bit 10	Bit 9	Bit 8	Bit 7	Bit 6	Bit 5	Bit 4	Bit 3	Bit 2
	0400-041E	See definition when WIN = x													
C1BUFPNT1	0420	F3BP3	F3BP2	F3BP1	F3BP0	F2BP3	F2BP2	F2BP1	F2BP0	F1BP3	F1BP2	F1BP1	F1BP0	F0BP3	F0BP1
C1BUFPNT2	0422	F7BP3	F7BP2	F7BP1	F7BP0	F6BP3	F6BP2	F6BP1	F6BP0	F5BP3	F5BP2	F5BP1	F5BP0	F4BP3	F4BP1
C1BUFPNT3	0424	F11BP3	F11BP2	F11BP1	F11BP0	F10BP3	F10BP2	F10BP1	F10BP0	F9BP3	F9BP2	F9BP1	F9BP0	F8BP3	F8BP1
C1BUFPNT4	0426	F15BP3	F15BP2	F15BP1	F15BP0	F14BP3	F14BP2	F14BP1	F14BP0	F13BP3	F13BP2	F13BP1	F13BP0	F12BP3	F12BP1
C1RXM0SID	0430	SID10	SID9	SID8	SID7	SID6	SID5	SID4	SID3	SID2	SID1	SID0	—	MIDE	—
C1RXM0EID	0432	EID<15:0>													
C1RXM1SID	0434	SID10	SID9	SID8	SID7	SID6	SID5	SID4	SID3	SID2	SID1	SID0	—	MIDE	—
C1RXM1EID	0436	EID<15:0>													
C1RXM2SID	0438	SID10	SID9	SID8	SID7	SID6	SID5	SID4	SID3	SID2	SID1	SID0	—	MIDE	—
C1RXM2EID	043A	EID<15:0>													
C1RXF0SID	0440	SID10	SID9	SID8	SID7	SID6	SID5	SID4	SID3	SID2	SID1	SID0	—	EXIDE	—
C1RXF0EID	0442	EID<15:0>													
C1RXF1SID	0444	SID10	SID9	SID8	SID7	SID6	SID5	SID4	SID3	SID2	SID1	SID0	—	EXIDE	—
C1RXF1EID	0446	EID<15:0>													
C1RXF2SID	0448	SID10	SID9	SID8	SID7	SID6	SID5	SID4	SID3	SID2	SID1	SID0	—	EXIDE	—
C1RXF2EID	044A	EID<15:0>													
C1RXF3SID	044C	SID10	SID9	SID8	SID7	SID6	SID5	SID4	SID3	SID2	SID1	SID0	—	EXIDE	—
C1RXF3EID	044E	EID<15:0>													
C1RXF4SID	0450	SID10	SID9	SID8	SID7	SID6	SID5	SID4	SID3	SID2	SID1	SID0	—	EXIDE	—
C1RXF4EID	0452	EID<15:0>													
C1RXF5SID	0454	SID10	SID9	SID8	SID7	SID6	SID5	SID4	SID3	SID2	SID1	SID0	—	EXIDE	—
C1RXF5EID	0456	EID<15:0>													
C1RXF6SID	0458	SID10	SID9	SID8	SID7	SID6	SID5	SID4	SID3	SID2	SID1	SID0	—	EXIDE	—
C1RXF6EID	045A	EID<15:0>													
C1RXF7SID	045C	SID10	SID9	SID8	SID7	SID6	SID5	SID4	SID3	SID2	SID1	SID0	—	EXIDE	—
C1RXF7EID	045E	EID<15:0>													
C1RXF8SID	0460	SID10	SID9	SID8	SID7	SID6	SID5	SID4	SID3	SID2	SID1	SID0	—	EXIDE	—
C1RXF8EID	0462	EID<15:0>													
C1RXF9SID	0464	SID10	SID9	SID8	SID7	SID6	SID5	SID4	SID3	SID2	SID1	SID0	—	EXIDE	—
C1RXF9EID	0466	EID<15:0>													
C1RXF10SID	0468	SID10	SID9	SID8	SID7	SID6	SID5	SID4	SID3	SID2	SID1	SID0	—	EXIDE	—
C1RXF10EID	046A	EID<15:0>													

Legend: x = unknown value on Reset; — = unimplemented, read as '0'. Reset values are shown in hexadecimal.

Note 1: These registers are not present on dsPIC33EPXXGM3XX devices.

TABLE 4-25: CAN1 REGISTER MAP WHEN WIN (C1CTRL<0>) = 1 FOR dsPIC33EPXXXGM60X7XX DEVICES⁽¹⁾ (CO

SFR Name	Addr.	Bit 15	Bit 14	Bit 13	Bit 12	Bit 11	Bit 10	Bit 9	Bit 8	Bit 7	Bit 6	Bit 5	Bit 4	Bit 3	Bit 2
C1RXF11SID	046C	SID10	SID9	SID8	SID7	SID6	SID5	SID4	SID3	SID2	SID1	SID0	—	EXIDE	—
C1RXF11EID	046E	EID<15:0>													
C1RXF12SID	0470	SID10	SID9	SID8	SID7	SID6	SID5	SID4	SID3	SID2	SID1	SID0	—	EXIDE	—
C1RXF12EID	0472	EID<15:0>													
C1RXF13SID	0474	SID10	SID9	SID8	SID7	SID6	SID5	SID4	SID3	SID2	SID1	SID0	—	EXIDE	—
C1RXF13EID	0476	EID<15:0>													
C1RXF14SID	0478	SID10	SID9	SID8	SID7	SID6	SID5	SID4	SID3	SID2	SID1	SID0	—	EXIDE	—
C1RXF14EID	047A	EID<15:0>													
C1RXF15SID	047C	SID10	SID9	SID8	SID7	SID6	SID5	SID4	SID3	SID2	SID1	SID0	—	EXIDE	—
C1RXF15EID	047E	EID<15:0>													

Legend: x = unknown value on Reset; — = unimplemented, read as '0'. Reset values are shown in hexadecimal.

Note 1: These registers are not present on dsPIC33EPXXXGM3XX devices.

TABLE 4-26: CAN2 REGISTER MAP WHEN WIN (C1CTRL<0>) = 0 OR 1 FOR dsPIC33EPXXXGM60X7XX DEVICES⁽¹⁾

SFR Name	Addr.	Bit 15	Bit 14	Bit 13	Bit 12	Bit 11	Bit 10	Bit 9	Bit 8	Bit 7	Bit 6	Bit 5	Bit 4	Bit 3	Bit 2
C2CTRL1	0500	—	—	CSIDL	ABAT	CANCKS	REOOP2	REOOP1	REOOP0	OPMODE2	OPMODE1	OPMODE0	—	CANCAP	—
C2CTRL2	0502	—	—	—	—	—	—	—	—	—	—	—	—	—	DNCNT<->
C2VEC	0504	—	—	—	FILHIT4	FILHIT3	FILHIT2	FILHIT1	FILHIT0	—	ICODE6	ICODE5	ICODE4	ICODE3	ICODE
C2FCTRL	0506	DMABS2	DMABS1	DMABS0	—	—	—	—	—	—	—	—	FSA4	FSA3	FSA2
C2FIFO	0508	—	—	FBP5	FBP4	FBP3	FBP2	FBP1	FBP0	—	—	FNRB5	FNRB4	FNRB3	FNRB2
C2INTF	050A	—	—	TXBO	TXBP	RXBP	TXWAR	RXWAR	EWARN	IVRIF	WAKIF	ERRIF	—	FIFOIF	RBOVI
C2INTE	050C	—	—	—	—	—	—	—	—	IVRIE	WAKIE	ERRIE	—	FIFOIE	RBOVI
C2EC	050E	TERRCNT7	TERRCNT6	TERRCNT5	TERRCNT4	TERRCNT3	TERRCNT2	TERRCNT1	TERRCNT0	RERRCNT7	RERRCNT6	RERRCNT5	RERRCNT4	RERRCNT3	RERRCNT2
C2CFG1	0510	—	—	—	—	—	—	—	—	SJW1	SJW0	BRP5	BRP4	BRP3	BRP2
C2CFG2	0512	—	WAKFIL	—	—	—	SEG2PH2	SEG2PH1	SEG2PH0	SEG2PHTS	SAM	SEG1PH2	SEG1PH1	SEG1PH0	PRSEC
C2FEN1	0514	FLTEN<15:0>													
C2FMSKSEL1	0518	F7MSK1	F7MSK0	F6MSK1	F6MSK0	F5MSK1	F5MSK0	F4MSK1	F4MSK0	F3MSK1	F3MSK0	F2MSK1	F2MSK0	F1MSK1	F1MSK0
C2FMSKSEL2	051A	F15MSK1	F15MSK0	F14MSK1	F14MSK0	F13MSK1	F13MSK0	F12MSK1	F12MSK0	F11MSK1	F11MSK0	F10MSK1	F10MSK0	F9MSK1	F9MSK0

Legend: — = unimplemented, read as '0'. Reset values are shown in hexadecimal.

Note 1: These registers are not present on dsPIC33EPXXXGM3XX devices.

TABLE 4-27: CAN2 REGISTER MAP WHEN WIN (C1CTRL<0>) = 0 FOR dsPIC33EPXXXGM60X/7XX DEVICES⁽¹⁾

SFR Name	Addr.	Bit 15	Bit 14	Bit 13	Bit 12	Bit 11	Bit 10	Bit 9	Bit 8	Bit 7	Bit 6	Bit 5	Bit 4	Bit 3	Bit
	0500-051E	See definition when WIN = x.													
C2RXFUL1	0520	RXFUL<15:0>													
C2RXFUL2	0522	RXFUL<31:16>													
C2RXOVF1	0528	RXOVF<15:0>													
C2RXOVF2	052A	RXOVF<31:16>													
C2TR01CON	0530	TXEN1	TXABT1	TXLARB1	TXERR1	TXREQ1	RTREN1	TX1PRI1	TX1PRI0	TXEN0	TXABAT0	TXLARB0	TXERR0	TXREQ0	RTRE
C2TR23CON	0532	TXEN3	TXABT3	TXLARB3	TXERR3	TXREQ3	RTREN3	TX3PRI1	TX3PRI0	TXEN2	TXABAT2	TXLARB2	TXERR2	TXREQ2	RTRE
C2TR45CON	0534	TXEN5	TXABT5	TXLARB5	TXERR5	TXREQ5	RTREN5	TX5PRI1	TX5PRI0	TXEN4	TXABAT4	TXLARB4	TXERR4	TXREQ4	RTRE
C2TR67CON	0536	TXEN7	TXABT7	TXLARB7	TXERR7	TXREQ7	RTREN7	TX7PRI1	TX7PRI0	TXEN6	TXABAT6	TXLARB6	TXERR6	TXREQ6	RTRE
C2RXD	0540	CAN2 Receive Data Word Register													
C2TXD	0542	CAN2 Transmit Data Word Register													

Legend: x = unknown value on Reset; — = unimplemented; read as '0'. Reset values are shown in hexadecimal.

Note 1: These registers are not present on dsPIC33EPXXXGM3XX devices.

TABLE 4-28: CAN2 REGISTER MAP WHEN WIN (C1CTRL<0>) = 1 FOR dsPIC33EPXXXGM60X/7XX DEVICES⁽¹⁾

SFR Name	Addr.	Bit 15	Bit 14	Bit 13	Bit 12	Bit 11	Bit 10	Bit 9	Bit 8	Bit 7	Bit 6	Bit 5	Bit 4	Bit 3	Bit 2
	0500-051E	See definition when WIN = x													
C2RUFNPT1	0520	F3BP3	F3BP2	F3BP1	F3BP0	F2BP3	F2BP2	F2BP1	F2BP0	F1BP3	F1BP2	F1BP1	F1BP0	F0BP3	F0BP0
C2RUFNPT2	0522	F7BP3	F7BP2	F7BP1	F7BP0	F6BP3	F6BP2	F6BP1	F6BP0	F5BP3	F5BP2	F5BP1	F5BP0	F4BP3	F4BP0
C2RUFNPT3	0524	F11BP3	F11BP2	F11BP1	F11BP0	F10BP3	F10BP2	F10BP1	F10BP0	F9BP3	F9BP2	F9BP1	F9BP0	F8BP3	F8BP0
C2RUFNPT4	0526	F15BP3	F15BP2	F15BP1	F15BP0	F14BP3	F14BP2	F14BP1	F14BP0	F13BP3	F13BP2	F13BP1	F13BP0	F12BP3	F12BP0
C2RXM0SID	0530	SID10	SID9	SID8	SID7	SID6	SID5	SID4	SID3	SID2	SID1	SID0	—	MIDE	—
C2RXM0EID	0532	EID<15:0>													
C2RXM1SID	0534	SID10	SID9	SID8	SID7	SID6	SID5	SID4	SID3	SID2	SID1	SID0	—	MIDE	—
C2RXM1EID	0536	EID<15:0>													
C2RXM2SID	0538	SID10	SID9	SID8	SID7	SID6	SID5	SID4	SID3	SID2	SID1	SID0	—	MIDE	—
C2RXM2EID	053A	EID<15:0>													
C2RXF0SID	0540	SID10	SID9	SID8	SID7	SID6	SID5	SID4	SID3	SID2	SID1	SID0	—	MIDE	—
C2RXF0EID	0542	EID<15:0>													
C2RXF1SID	0544	SID10	SID9	SID8	SID7	SID6	SID5	SID4	SID3	SID2	SID1	SID0	—	MIDE	—
C2RXF1EID	0546	EID<15:0>													
C2RXF2SID	0548	SID10	SID9	SID8	SID7	SID6	SID5	SID4	SID3	SID2	SID1	SID0	—	MIDE	—
C2RXF2EID	054A	EID<15:0>													
C2RXF3SID	054C	SID10	SID9	SID8	SID7	SID6	SID5	SID4	SID3	SID2	SID1	SID0	—	MIDE	—
C2RXF3EID	054E	EID<15:0>													
C2RXF4SID	0550	SID10	SID9	SID8	SID7	SID6	SID5	SID4	SID3	SID2	SID1	SID0	—	MIDE	—
C2RXF4EID	0552	EID<15:0>													
C2RXF5SID	0554	SID10	SID9	SID8	SID7	SID6	SID5	SID4	SID3	SID2	SID1	SID0	—	MIDE	—
C2RXF5EID	0556	EID<15:0>													
C2RXF6SID	0558	SID10	SID9	SID8	SID7	SID6	SID5	SID4	SID3	SID2	SID1	SID0	—	MIDE	—
C2RXF6EID	055A	EID<15:0>													
C2RXF7SID	055C	SID10	SID9	SID8	SID7	SID6	SID5	SID4	SID3	SID2	SID1	SID0	—	MIDE	—
C2RXF7EID	055E	EID<15:0>													
C2RXF8SID	0560	SID10	SID9	SID8	SID7	SID6	SID5	SID4	SID3	SID2	SID1	SID0	—	MIDE	—
C2RXF8EID	0562	EID<15:0>													
C2RXF9SID	0564	SID10	SID9	SID8	SID7	SID6	SID5	SID4	SID3	SID2	SID1	SID0	—	MIDE	—
C2RXF9EID	0566	EID<15:0>													
C2RXF10SID	0568	SID10	SID9	SID8	SID7	SID6	SID5	SID4	SID3	SID2	SID1	SID0	—	MIDE	—
C2RXF10EID	056A	EID<15:0>													

Legend: x = unknown value on Reset; — = unimplemented, read as '0'. Reset values are shown in hexadecimal.

Note 1: These registers are not present on dsPIC33EPXXXGM3XX devices.

TABLE 4-28: CAN2 REGISTER MAP WHEN WIN (C1CTRL<0>) = 1 FOR dsPIC33EPXXXGM60X/7XX DEVICES⁽¹⁾ (CO

SFR Name	Addr.	Bit 15	Bit 14	Bit 13	Bit 12	Bit 11	Bit 10	Bit 9	Bit 8	Bit 7	Bit 6	Bit 5	Bit 4	Bit 3	Bit 2
C2RXF11SID	056C	SID10	SID9	SID8	SID7	SID6	SID5	SID4	SID3	SID2	SID1	SID0	—	EXIDE	—
C2RXF11EID	056E	EID<15:0>													
C2RXF12SID	0570	SID10	SID9	SID8	SID7	SID6	SID5	SID4	SID3	SID2	SID1	SID0	—	MIDE	—
C2RXF12EID	0572	EID<15:0>													
C2RXF13SID	0574	SID10	SID9	SID8	SID7	SID6	SID5	SID4	SID3	SID2	SID1	SID0	—	MIDE	—
C2RXF13EID	0576	EID<15:0>													
C2RXF14SID	0578	SID10	SID9	SID8	SID7	SID6	SID5	SID4	SID3	SID2	SID1	SID0	—	MIDE	—
C2RXF14EID	057A	EID<15:0>													
C2RXF15SID	057C	SID10	SID9	SID8	SID7	SID6	SID5	SID4	SID3	SID2	SID1	SID0	—	MIDE	—
C2RXF15EID	057E	EID<15:0>													

Legend: x = unknown value on Reset; — = unimplemented, read as '0'. Reset values are shown in hexadecimal.

Note 1: These registers are not present on dsPIC33EPXXXGM3XX devices.

TABLE 4-29: PROGRAMMABLE CRC REGISTER MAP

SFR Name	Addr.	Bit 15	Bit 14	Bit 13	Bit 12	Bit 11	Bit 10	Bit 9	Bit 8	Bit 7	Bit 6	Bit 5	Bit 4	Bit 3	Bit
CRCCON1	0640	CRCE	—	CSIDL	VWORD4	VWORD3	VWORD2	VWORD1	VWORD0	CRCFUL	CRCMPT	CRCISEL	CRCGO	LEN4IAN	PLE
CRCCON2	0642	—	—	DWIDTH4	DWIDTH3	DWIDTH2	DWIDTH1	DWIDTH0	—	—	—	—	PLEN4	PLEN3	PLE
CRCXORL	0644	X<15:1>													
CRCXORH	0646	X<31:16>													
CRCDATL	0648	CRC Data Input Low Word Register													
CRCDATH	064A	CRC Data Input High Word Register													
CRCDATL	064C	CRC Result Low Word Register													
CRCDATH	064E	CRC Result High Word Register													

Legend: — = unimplemented, read as '0'. Shaded bits are not used in the operation of the programmable CRC module.

TABLE 4-30: PERIPHERAL PIN SELECT OUTPUT REGISTER MAP FOR dsPIC33EPXXXGM304/604 DEVICES

SFR Name	Addr.	Bit 15	Bit 14	Bit 13	Bit 12	Bit 11	Bit 10	Bit 9	Bit 8	Bit 7	Bit 6	Bit 5	Bit 4	Bit 3	Bit 2
RPOR0	0680	—	—	—	—	RP35R<5:0>	—	—	—	—	—	—	—	RP20R<5:0>	RP36R<5:0>
RPOR1	0682	—	—	—	—	RP37R<5:0>	—	—	—	—	—	—	—	RP38R<5:0>	RP40R<5:0>
RPOR2	0684	—	—	—	—	RP39R<5:0>	—	—	—	—	—	—	—	RP42R<5:0>	RP48R<5:0>
RPOR3	0686	—	—	—	—	RP41R<5:0>	—	—	—	—	—	—	—	RP44R<5:0>	RP50R<5:0>
RPOR4	0688	—	—	—	—	RP43R<5:0>	—	—	—	—	—	—	—	RP46R<5:0>	RP52R<5:0>
RPOR5	068A	—	—	—	—	RP45R<5:0>	—	—	—	—	—	—	—	RP48R<5:0>	RP54R<5:0>
RPOR6	068C	—	—	—	—	RP47R<5:0>	—	—	—	—	—	—	—	RP50R<5:0>	RP56R<5:0>
RPOR7	068E	—	—	—	—	RP49R<5:0>	—	—	—	—	—	—	—	RP52R<5:0>	RP58R<5:0>

Legend: — = unimplemented, read as '0'. Reset values are shown in hexadecimal.

TABLE 4-31: PERIPHERAL PIN SELECT OUTPUT REGISTER MAP FOR dsPIC33EPXXXGM306/706 DEVICES

SFR Name	Addr.	Bit 15	Bit 14	Bit 13	Bit 12	Bit 11	Bit 10	Bit 9	Bit 8	Bit 7	Bit 6	Bit 5	Bit 4	Bit 3	Bit 2
RPOR0	0680	—	—	—	—	RP35R<5:0>	—	—	—	—	—	—	—	RP20R<5:0>	RP36R<5:0>
RPOR1	0682	—	—	—	—	RP37R<5:0>	—	—	—	—	—	—	—	RP38R<5:0>	RP40R<5:0>
RPOR2	0684	—	—	—	—	RP39R<5:0>	—	—	—	—	—	—	—	RP42R<5:0>	RP48R<5:0>
RPOR3	0686	—	—	—	—	RP41R<5:0>	—	—	—	—	—	—	—	RP44R<5:0>	RP50R<5:0>
RPOR4	0688	—	—	—	—	RP43R<5:0>	—	—	—	—	—	—	—	RP46R<5:0>	RP52R<5:0>
RPOR5	068A	—	—	—	—	RP45R<5:0>	—	—	—	—	—	—	—	RP48R<5:0>	RP54R<5:0>
RPOR6	068C	—	—	—	—	RP47R<5:0>	—	—	—	—	—	—	—	RP50R<5:0>	RP56R<5:0>
RPOR7	068E	—	—	—	—	RP49R<5:0>	—	—	—	—	—	—	—	RP52R<5:0>	RP58R<5:0>
RPOR8	0690	—	—	—	—	RP70R<5:0>	—	—	—	—	—	—	—	RP69R<5:0>	—
RPOR9	0692	—	—	—	—	RP97R<5:0>	—	—	—	—	—	—	—	—	—

Legend: — = unimplemented, read as '0'. Reset values are shown in hexadecimal.

TABLE 4-32: PERIPHERAL PIN SELECT OUTPUT REGISTER MAP FOR dsPIC33EPXXGM310/710 DEVICES

SFR Name	Addr.	Bit 15	Bit 14	Bit 13	Bit 12	Bit 11	Bit 10	Bit 9	Bit 8	Bit 7	Bit 6	Bit 5	Bit 4	Bit 3	Bit 2
RPOR0	0680	—	—	—	—	RP35R<5:0>	—	—	—	—	—	—	—	RP20R<5:0>	RP36R<5:0>
RPOR1	0682	—	—	—	—	RP37R<5:0>	—	—	—	—	—	—	—	RP38R<5:0>	RP40R<5:0>
RPOR2	0684	—	—	—	—	RP39R<5:0>	—	—	—	—	—	—	—	RP42R<5:0>	RP48R<5:0>
RPOR3	0686	—	—	—	—	RP41R<5:0>	—	—	—	—	—	—	—	RP44R<5:0>	RP54R<5:0>
RPOR4	0688	—	—	—	—	RP43R<5:0>	—	—	—	—	—	—	—	RP46R<5:0>	RP56R<5:0>
RPOR5	068A	—	—	—	—	RP49R<5:0>	—	—	—	—	—	—	—	RP69R<5:0>	RP81R<5:0>
RPOR6	068C	—	—	—	—	RP55R<5:0>	—	—	—	—	—	—	—	RP113R<5:0>	RPR120R<5:0>
RPOR7	068E	—	—	—	—	RP57R<5:0>	—	—	—	—	—	—	—	RPR126R<5:0>	—
RPOR8	0690	—	—	—	—	RP70R<5:0>	—	—	—	—	—	—	—	—	—
RPOR9	0692	—	—	—	—	RP97R<5:0>	—	—	—	—	—	—	—	—	—
RPOR10	0694	—	—	—	—	RP118R<5:0>	—	—	—	—	—	—	—	—	—
RPOR11	0696	—	—	—	—	RPR125R<5:0>	—	—	—	—	—	—	—	—	—
RPOR12	0698	—	—	—	—	RPR127R<5:0>	—	—	—	—	—	—	—	—	—

Legend: — = unimplemented, read as '0'. Reset values are shown in hexadecimal.

TABLE 4-33: PERIPHERAL PIN SELECT INPUT REGISTER MAP FOR dsPIC33EPXXGM60X/7XX DEVICES

SFR Name	Addr.	Bit 15	Bit 14	Bit 13	Bit 12	Bit 11	Bit 10	Bit 9	Bit 8	Bit 7	Bit 6	Bit 5	Bit 4	Bit 3	Bit 2
RPINR0	06A0	—	—	—	INT1R<6:0>	—	—	—	—	—	—	—	—	—	—
RPINR1	06A2	—	—	—	—	—	—	—	—	—	—	—	—	INT2R<6:0>	—
RPINR3	06A6	—	—	—	—	—	—	—	—	—	—	—	—	T2CKR<6:0>	—
RPINR7	06AE	—	—	—	IC2R<6:0>	—	—	—	—	—	—	—	—	IC1R<6:0>	—
RPINR8	06B0	—	—	—	IC4R<6:0>	—	—	—	—	—	—	—	—	IC3R<6:0>	—
RPINR9	06B2	—	—	—	IC6R<6:0>	—	—	—	—	—	—	—	—	IC5R<6:0>	—
RPINR10	06B4	—	—	—	IC8R<6:0>	—	—	—	—	—	—	—	—	IC7R<6:0>	—
RPINR11	06B6	—	—	—	—	—	—	—	—	—	—	—	—	OCFAR<6:0>	—
RPINR12	06B8	—	—	—	FLT2R<6:0>	—	—	—	—	—	—	—	—	FLT1R<6:0>	—
RPINR14	06BC	—	—	—	QEB1R<6:0>	—	—	—	—	—	—	—	—	QEA1R<6:0>	—
RPINR15	06BE	—	—	—	HOME1R<6:0>	—	—	—	—	—	—	—	—	INDX1R<6:0>	—
RPINR16	06C0	—	—	—	QEB2R<6:0>	—	—	—	—	—	—	—	—	QEA2R<6:0>	—
RPINR17	06C2	—	—	—	HOME2R<6:0>	—	—	—	—	—	—	—	—	INDX2R<6:0>	—
RPINR18	06C4	—	—	—	—	—	—	—	—	—	—	—	—	U1RXR<6:0>	—
RPINR19	06C6	—	—	—	—	—	—	—	—	—	—	—	—	U2RXR<6:0>	—
RPINR22	06CC	—	—	—	SCK2R<6:0>	—	—	—	—	—	—	—	—	SDI2R<6:0>	—
RPINR23	06CE	—	—	—	—	—	—	—	—	—	—	—	—	SS2R<6:0>	—
RPINR24	06D0	—	—	—	CCKR<6:0>	—	—	—	—	—	—	—	—	CSDIR<6:0>	—
RPINR25	06D2	—	—	—	—	—	—	—	—	—	—	—	—	COFSR<6:0>	—
RPINR26	06D4	—	—	—	C2RXR<6:0>	—	—	—	—	—	—	—	—	C1RXR<6:0>	—
RPINR27	06D6	—	—	—	U3CTSR<6:0>	—	—	—	—	—	—	—	—	U3RXR<6:0>	—
RPINR28	06D8	—	—	—	U4CTSR<6:0>	—	—	—	—	—	—	—	—	U4RXR<6:0>	—
RPINR29	06DA	—	—	—	SCK3R<6:0>	—	—	—	—	—	—	—	—	SDI3R<6:0>	—
RPINR30	06DC	—	—	—	—	—	—	—	—	—	—	—	—	SS3R<6:0>	—
RPINR37	06EA	—	—	—	SYNC11R<6:0>	—	—	—	—	—	—	—	—	—	—
RPINR38	06EC	—	—	—	DTCMP1R<6:0>	—	—	—	—	—	—	—	—	—	—
RPINR39	06EE	—	—	—	DTCMP3R<6:0>	—	—	—	—	—	—	—	—	DTCMP2R<6:0>	—
RPINR40	06F0	—	—	—	DTCMP5R<6:0>	—	—	—	—	—	—	—	—	DTCMP4R<6:0>	—
RPINR41	06F2	—	—	—	—	—	—	—	—	—	—	—	—	DTCMP6R<6:0>	—

Legend: — = unimplemented, read as '0'. Reset values are shown in hexadecimal.

TABLE 4-34: PERIPHERAL PIN SELECT INPUT REGISTER MAP FOR dsPIC33EPXXGM3XX DEVICES

SFR Name	Addr.	Bit 15	Bit 14	Bit 13	Bit 12	Bit 11	Bit 10	Bit 9	Bit 8	Bit 7	Bit 6	Bit 5	Bit 4	Bit 3	Bit 2
RPINR0	06A0	—	—	—	INT1R<6:0>	—	—	—	—	—	—	—	—	—	—
RPINR1	06A2	—	—	—	—	—	—	—	—	—	—	—	—	INT2R<6:0>	—
RPINR3	06A6	—	—	—	—	—	—	—	—	—	—	—	—	T2CKR<6:0>	—
RPINR7	06AE	—	—	—	IC2R<6:0>	—	—	—	—	—	—	—	—	IC1R<6:0>	—
RPINR8	06B0	—	—	—	IC4R<6:0>	—	—	—	—	—	—	—	—	IC3R<6:0>	—
RPINR9	06B2	—	—	—	IC6R<6:0>	—	—	—	—	—	—	—	—	IC5R<6:0>	—
RPINR10	06B4	—	—	—	IC8R<6:0>	—	—	—	—	—	—	—	—	IC7R<6:0>	—
RPINR11	06B6	—	—	—	—	—	—	—	—	—	—	—	—	OCFAR<6:0>	—
RPINR12	06B8	—	—	—	FLT2R<6:0>	—	—	—	—	—	—	—	—	FLT1R<6:0>	—
RPINR14	06BC	—	—	—	QEB1R<6:0>	—	—	—	—	—	—	—	—	QEA1R<6:0>	—
RPINR15	06BE	—	—	—	HOME1R<6:0>	—	—	—	—	—	—	—	—	INDX1R<6:0>	—
RPINR16	06C0	—	—	—	QEB2R<6:0>	—	—	—	—	—	—	—	—	QEA2R<6:0>	—
RPINR17	06C2	—	—	—	HOME2R<6:0>	—	—	—	—	—	—	—	—	INDX2R<6:0>	—
RPINR18	06C4	—	—	—	—	—	—	—	—	—	—	—	—	U1RXR<6:0>	—
RPINR19	06C6	—	—	—	—	—	—	—	—	—	—	—	—	U2RXR<6:0>	—
RPINR22	06CC	—	—	—	SCK2R<6:0>	—	—	—	—	—	—	—	—	SDI2R<6:0>	—
RPINR23	06CE	—	—	—	—	—	—	—	—	—	—	—	—	SS2R<6:0>	—
RPINR24	06D0	—	—	—	CCKR<6:0>	—	—	—	—	—	—	—	—	CSDJR<6:0>	—
RPINR25	06D2	—	—	—	—	—	—	—	—	—	—	—	—	COFSR<6:0>	—
RPINR27	06D6	—	—	—	U3CTSR<6:0>	—	—	—	—	—	—	—	—	U3RXR<6:0>	—
RPINR28	06D8	—	—	—	U4CTSR<6:0>	—	—	—	—	—	—	—	—	U4RXR<6:0>	—
RPINR29	06DA	—	—	—	SCK3R<6:0>	—	—	—	—	—	—	—	—	SDI3R<6:0>	—
RPINR30	06DC	—	—	—	—	—	—	—	—	—	—	—	—	SS3R<6:0>	—
RPINR37	06EA	—	—	—	SYNCI1R<6:0>	—	—	—	—	—	—	—	—	—	—
RPINR38	06EC	—	—	—	DTCMP1R<6:0>	—	—	—	—	—	—	—	—	—	—
RPINR39	06EE	—	—	—	DTCMP3R<6:0>	—	—	—	—	—	—	—	—	—	—
RPINR40	06F0	—	—	—	DTCMP9R<6:0>	—	—	—	—	—	—	—	—	—	—
RPINR41	06F2	—	—	—	—	—	—	—	—	—	—	—	—	—	—

Legend: — = unimplemented, read as '0'. Reset values are shown in hexadecimal.

TABLE 4-35: NVM REGISTER MAP

SFR Name	Addr.	Bit 15	Bit 14	Bit 13	Bit 12	Bit 11	Bit 10	Bit 9	Bit 8	Bit 7	Bit 6	Bit 5	Bit 4	Bit 3	Bit 2	Bit 1
NVMCON	0728	WR	WREN	WRERR	NVMSIDL	—	—	RPDF	URERR	—	—	—	—	NVMOP3	NVMOP2	NVMOP1
NVMADR	072A	NVMADR<15:0>														
NVMADRU	072C	—	—	—	—	—	—	—	—	—	—	—	—	—	—	NVMADRU<23:16>
NVMKEY	072E	—	—	—	—	—	—	—	—	—	—	—	—	—	—	NVMKEY<7:0>
NVMSRCADR1	0730	NVMSRCADR<15:1>														
NVMSRCADRH	0732	—	—	—	—	—	—	—	—	—	—	—	—	—	—	NVMSRCADRH<23:16>

Legend: — = unimplemented, read as '0'. Reset values are shown in hexadecimal.

TABLE 4-36: SYSTEM CONTROL REGISTER MAP

SFR Name	Addr.	Bit 15	Bit 14	Bit 13	Bit 12	Bit 11	Bit 10	Bit 9	Bit 8	Bit 7	Bit 6	Bit 5	Bit 4	Bit 3	Bit 2	Bit 1
RCON	0740	TRAPR	IOPUWR	—	—	VREGSF	—	CM	VREGS	EXTR	SWR	SWDTEN	WDTO	SLEEP	IDLE	—
OSCCON	0742	—	COSC2	COSC1	COSC0	—	NOOSC2	NOOSC1	NOOSC0	CLKLOCK	IOLOCK	LOCK	—	CF	—	—
CLKDIV	0744	ROI	DOZE2	DOZE1	DOZE0	DOZEN	FRCDIV2	FRCDIV1	FRCDIV0	PLLPOST1	PLLPOST0	—	PLLPRE4	PLLPRE3	PLLPRE2	PLLPRE1
PLLFBD	0746	—	—	—	—	—	—	—	—	—	—	—	—	—	—	—
OSCTUN	0748	—	—	—	—	—	—	—	—	—	—	—	—	—	—	—
PLL DIV<8:0>																
TUN<5:0>																

Legend: — = unimplemented, read as '0'. Reset values are shown in hexadecimal.

Note 1: RCON register Reset values are dependent on the type of Reset.

2: OSCCON register Reset values are dependent on the configuration fuses.

TABLE 4-37: REFERENCE CLOCK REGISTER MAP

SFR Name	Addr.	Bit 15	Bit 14	Bit 13	Bit 12	Bit 11	Bit 10	Bit 9	Bit 8	Bit 7	Bit 6	Bit 5	Bit 4	Bit 3	Bit 2	Bit 1
REFOCON	074E	ROON	—	ROSSLP	ROSEL	RODIV3	RODIV2	RODIV1	RODIV0	—	—	—	—	—	—	—

Legend: — = unimplemented, read as '0'. Reset values are shown in hexadecimal.

TABLE 4-38: PARALLEL MASTER/SLAVE PORT REGISTER MAP⁽²⁾

SFR Name	Addr.	Bit 15	Bit 14	Bit 13	Bit 12	Bit 11	Bit 10	Bit 9	Bit 8	Bit 7	Bit 6	Bit 5	Bit 4	Bit 3	Bit 2
PMCON	0600	PMPEN	—	PSIDL	ADRMUX1	ADRMUX0	PTBEEN	PTWREN	PTRDEN	CSF1	CSF0	ALP	CS2P	CS1P	BE1
PMMODE	0602	BUSY	IRQM1	IRQM0	INCM1	INCM0	MODE16	MODE1	MODE0	WAITB1	WAITB0	WAITM3	WAITM2	WAITM1	WAIT
PMADDR ⁽¹⁾	0604	CS2	CS1	Parallel Port Address Register (ADDR<13:0>)											
PMDOU ⁽¹⁾	0604	Parallel Port Data Out Register 1 (Buffer Levels 0 and 1)													
PMDOU2	0606	Parallel Port Data Out Register 2 (Buffer Levels 2 and 3)													
PM ⁽¹⁾ DIN1	0608	Parallel Port Data In Register 1 (Buffer Levels 0 and 1)													
PM ⁽¹⁾ DIN2	060A	Parallel Port Data In Register 2 (Buffer Levels 2 and 3)													
PMAEN	060C	PTEN<15:0>													
PMSTAT	060E	IBF	IBOV	—	—	IB3F	IB2F	IB1F	IB0F	OBE	OBUF	—	—	OB3E	OB2

Legend: — = unimplemented, read as '0'. Shaded bits are not used in the operation of the PMP module.

Note 1: PMADDR and PMDOU⁽¹⁾ are the same physical register, but are defined differently depending on the module's operating mode.

2: PMP is not present on 44-pin devices.

TABLE 4-39: PMD REGISTER MAP FOR dsPIC33EPXXXGM6XX/7XX DEVICES

SFR Name	Addr.	Bit 15	Bit 14	Bit 13	Bit 12	Bit 11	Bit 10	Bit 9	Bit 8	Bit 7	Bit 6	Bit 5	Bit 4	Bit 3	Bit 2
PMD1	0760	T5MD	T4MD	T3MD	T2MD	T1MD	QEIMD	PWMMD	DCIMD	I2C1MD	U2MD	U1MD	SP12MD	SP11MD	C2MD
PMD2	0762	IC8MD	IC7MD	IC6MD	IC5MD	IC4MD	IC3MD	IC2MD	IC1MD	OC8MD	OC7MD	OC6MD	OC5MD	OC4MD	OC3MD
PMD3	0764	T9MD	T8MD	T7MD	T6MD	—	CMPMD	RTCCMD ⁽¹⁾	PMPMD	CRCMD	DACMD	QE12MD	PWM2MD	U3MD	I2C3MD
PMD4	0766	—	—	—	—	—	—	—	—	—	—	U4MD	—	REFOMD	CTMUN
PMD6	076A	—	—	PWM6MD	PWM5MD	PWM4MD	PWM3MD	PWM2MD	PWM1MD	—	—	—	—	—	—
PMD7	076C	—	—	—	—	—	—	—	—	—	—	—	DMA0MD	PTGMD	—
													DMA1MD		
													DMA2MD		
													DMA3MD		

Legend: — = unimplemented, read as '0'. Reset values are shown in hexadecimal.

Note 1: The RTCCMD bit is not available on 44-pin devices.

TABLE 4-40: PMD REGISTER MAP FOR dsPIC33EPXXXGM3XX DEVICES

SFR Name	Addr.	Bit 15	Bit 14	Bit 13	Bit 12	Bit 11	Bit 10	Bit 9	Bit 8	Bit 7	Bit 6	Bit 5	Bit 4	Bit 3	Bit 2
PMD1	0760	T5MD	T4MD	T3MD	T2MD	T1MD	QE11MD	PWMMD	DC1MD	I2C1MD	U2MD	U1MD	SPI2MD	SF11MD	—
PMD2	0762	IC8MD	IC7MD	IC6MD	IC5MD	IC4MD	IC3MD	IC2MD	IC1MD	OC8MD	OC7MD	OC6MD	OC5MD	OC4MD	OC3MD
PMD3	0764	T9MD	T8MD	T7MD	T6MD	—	CMPMD	RTCCMD ⁽¹⁾	PMPMD	CRCMD	—	QE12MD	—	U3MD	—
PMD4	0766	—	—	—	—	—	—	—	—	—	—	U4MD	—	REFOMD	CTMUN
PMD6	076A	—	—	PWM6MD	PWM5MD	PWM4MD	PWM3MD	PWM2MD	PWM1MD	—	—	—	DMA0MD	—	—
PMD7	076C	—	—	—	—	—	—	—	—	—	—	—	DMA1MD	PTGMD	—
													DMA2MD		
													DMA3MD		

Legend: — = unimplemented, read as '0'. Reset values are shown in hexadecimal.

Note 1: The RTCCMD bit is not available on 44-pin devices.

TABLE 4-41: OP AMP/COMPARATOR REGISTER MAP

SFR Name	Addr.	Bit 15	Bit 14	Bit 13	Bit 12	Bit 11	Bit 10	Bit 9	Bit 8	Bit 7	Bit 6	Bit 5	Bit 4	Bit 3	Bit 2
CM5STAT	0A80	PSIDL	—	—	C5EVT	C4EVT	C3EVT	C2EVT	C1EVT	—	—	—	C5OUT	C4OUT	C3OUT
CVR1CON	0A82	—	—	—	—	CVRR1	VREFSEL	—	—	CVREN	CVROE	CVRR0	CVRSS	CVR3	CVR2
CM1CON	0A84	CON	COE	CPOL	—	—	OPMODE	CEVT	COUT	VPOL1	VPOL0	—	CREF	—	—
CM1MSKSR	0A86	—	—	—	—	SELSRCC3	SELSRCC2	SELSRCC1	SELSRCC0	SELSRCC3	SELSRCC2	SELSRCC1	SELSRCC0	SELSRCA3	SELSRCA2
CM1MSKCON	0A88	HLMS	—	OCEN	OCNEN	OBEN	OBNEN	OAEN	OANEN	NAGS	PAGS	ACEN	ACNEN	ABEN	ABNEN
CM1FLTR	0A8A	—	—	—	—	—	—	—	—	—	CFSEL2	CFSEL1	CFSEL0	CFLTREN	CFDW2
CM2CON	0A8C	CON	COE	CPOL	—	—	OPMODE	CEVT	COUT	VPOL1	VPOL0	—	CREF	—	—
CM2MSKSR	0A8E	—	—	—	—	SELSRCC3	SELSRCC2	SELSRCC1	SELSRCC0	SELSRCC3	SELSRCC2	SELSRCC1	SELSRCC0	SELSRCA3	SELSRCA2
CM2MSKCON	0A90	HLMS	—	OCEN	OCNEN	OBEN	OBNEN	OAEN	OANEN	NAGS	PAGS	ACEN	ACNEN	ABEN	ABNEN
CM2FLTR	0A92	—	—	—	—	—	—	—	—	—	CFSEL2	CFSEL1	CFSEL0	CFLTREN	CFDW2
CM3CON	0A94	CON	COE	CPOL	—	—	OPMODE	CEVT	COUT	VPOL1	VPOL0	—	CREF	—	—
CM3MSKSR	0A96	—	—	—	—	SELSRCC3	SELSRCC2	SELSRCC1	SELSRCC0	SELSRCC3	SELSRCC2	SELSRCC1	SELSRCC0	SELSRCA3	SELSRCA2
CM3MSKCON	0A98	HLMS	—	OCEN	OCNEN	OBEN	OBNEN	OAEN	OANEN	NAGS	PAGS	ACEN	ACNEN	ABEN	ABNEN
CM3FLTR	0A9A	—	—	—	—	—	—	—	—	—	CFSEL2	CFSEL1	CFSEL0	CFLTREN	CFDW2
CM4CON	0A9C	CON	COE	CPOL	—	—	—	—	COUT	VPOL1	VPOL0	—	CREF	—	—
CM4MSKSR	0A9E	—	—	—	—	SELSRCC3	SELSRCC2	SELSRCC1	SELSRCC0	SELSRCC3	SELSRCC2	SELSRCC1	SELSRCC0	SELSRCA3	SELSRCA2
CM4MSKCON	0AA0	HLMS	—	OCEN	OCNEN	OBEN	OBNEN	OAEN	OANEN	NAGS	PAGS	ACEN	ACNEN	ABEN	ABNEN
CM4FLTR	0AA2	—	—	—	—	—	—	—	—	—	CFSEL2	CFSEL1	CFSEL0	CFLTREN	CFDW2
CM5CON	0AA4	CON	COE	CPOL	—	—	OPMODE	CEVT	COUT	VPOL1	VPOL0	—	CREF	—	—
CM5MSKSR	0AA6	—	—	—	—	SELSRCC3	SELSRCC2	SELSRCC1	SELSRCC0	SELSRCC3	SELSRCC2	SELSRCC1	SELSRCC0	SELSRCA3	SELSRCA2
CM5MSKCON	0AA8	HLMS	—	OCEN	OCNEN	OBEN	OBNEN	OAEN	OANEN	NAGS	PAGS	ACEN	ACNEN	ABEN	ABNEN
CM5FLTR	0AAA	—	—	—	—	—	—	—	—	—	CFSEL2	CFSEL1	CFSEL0	CFLTREN	CFDW2
CVR2CON	0AB4	—	—	—	—	CVRR1	VREFSEL	—	—	CVREN	CVROE	CVRR0	CVRSS	CVR3	CVR2

Legend: — = unimplemented, read as '0'. Reset values are shown in hexadecimal.

TABLE 4-42: CTMU REGISTER MAP

SFR Name	Addr.	Bit 15	Bit 14	Bit 13	Bit 12	Bit 11	Bit 10	Bit 9	Bit 8	Bit 7	Bit 6	Bit 5	Bit 4	Bit 3
CTMUICON1	033A	CTMUEN	—	CTMUSIDL	TGEN	EDGEN	EDGSEQEN	IDISSEN	CTTRIG	—	—	—	—	—
CTMUICON2	033C	EDG1MOD	EDG1POL	EDG1SEL3	EDG1SEL2	EDG1SEL1	EDG1SEL0	EDG2STAT	EDG1STAT	EDG2MOD	EDG2POL	EDG2SEL3	EDG2SEL2	EDG2SEL
CTMUICON	033E	ITRIM5	ITRIM4	ITRIM3	ITRIM2	ITRIM1	ITRIM0	IRNG1	IRNG0	—	—	—	—	—

Legend: — = unimplemented, read as '0'. Reset values are shown in hexadecimal.

TABLE 4-43: JTAG INTERFACE REGISTER MAP

SFR Name	Addr.	Bit 15	Bit 14	Bit 13	Bit 12	Bit 11	Bit 10	Bit 9	Bit 8	Bit 7	Bit 6	Bit 5	Bit 4	Bit 3	Bit 2
JDATAH	0FF0	—	—	—	—	—	—	—	—	—	—	—	—	—	—
JDATAJ	0FF2	—	—	—	—	—	—	—	—	—	—	—	—	—	—

JDATAH<27:16>

JDATAJ<15:0>

Legend: x = unknown value on Reset; — = unimplemented, read as '0'. Reset values are shown in hexadecimal.

TABLE 4-44: REAL-TIME CLOCK AND CALENDAR REGISTER MAP

File Name	Addr.	Bit 15	Bit 14	Bit 13	Bit 12	Bit 11	Bit 10	Bit 9	Bit 8	Bit 7	Bit 6	Bit 5	Bit 4	Bit 3	Bit 2	
ALRMVAL	0620	Alarm Value Register Window Based on ALRMPTR<1:0>														
ALCFGRPT	0622	ALRMEN	CHIME	AMASK3	AMASK2	AMASK1	AMASK0	ALRMPTR1	ALRMPTR0	ARPT7	ARPT6	ARPT5	ARPT4	ARPT3	ARPT2	
RTCVAL	0624	RTCC Value Register Window Based on RTCPTR<1:0>														
RCFGCAL	0626	RTCEN	—	RTCWREN	RTCSYNC	HALFSEC	RTCOE	RTCPTR1	RTCPTR0	CAL7	CAL6	CAL5	CAL4	CAL3	CAL2	

Legend: x = unknown value on Reset; — = unimplemented, read as '0'. Reset values are shown in hexadecimal.

TABLE 4-45: DMA CONTROLLER REGISTER MAP

SFR Name	Addr.	Bit 15	Bit 14	Bit 13	Bit 12	Bit 11	Bit 10	Bit 9	Bit 8	Bit 7	Bit 6	Bit 5	Bit 4	Bit 3	Bit
DMA0CON	0B00	CHEN	SIZE	DIR	HALF	NULLW	—	—	—	—	—	—	—	—	—
DMA0REQ	0B02	FORCE	—	—	—	—	—	—	—	IRQSEL7	IRQSEL6	IRQSEL5	AMODE0	IRQSEL3	IRQS
DMA0STAL	0B04	—	—	—	—	—	—	—	—	—	—	—	—	—	—
DMA0STAH	0B06	—	—	—	—	—	—	—	—	—	—	—	—	—	—
DMA0STBL	0B08	—	—	—	—	—	—	—	—	—	—	—	—	—	—
DMA0STBH	0B0A	—	—	—	—	—	—	—	—	—	—	—	—	—	—
DMA0PAD	0B0C	—	—	—	—	—	—	—	—	—	—	—	—	—	—
DMA0CNT	0B0E	—	—	—	—	—	—	—	—	—	—	—	—	—	—
DMA1CON	0B10	CHEN	SIZE	DIR	HALF	NULLW	—	—	—	—	—	—	—	—	—
DMA1REQ	0B12	FORCE	—	—	—	—	—	—	—	IRQSEL7	IRQSEL6	IRQSEL5	AMODE0	IRQSEL3	IRQS
DMA1STAL	0B14	—	—	—	—	—	—	—	—	—	—	—	—	—	—
DMA1STAH	0B16	—	—	—	—	—	—	—	—	—	—	—	—	—	—
DMA1STBL	0B18	—	—	—	—	—	—	—	—	—	—	—	—	—	—
DMA1STBH	0B1A	—	—	—	—	—	—	—	—	—	—	—	—	—	—
DMA1PAD	0B1C	—	—	—	—	—	—	—	—	—	—	—	—	—	—
DMA1CNT	0B1E	—	—	—	—	—	—	—	—	—	—	—	—	—	—
DMA2CON	0B20	CHEN	SIZE	DIR	HALF	NULLW	—	—	—	—	—	—	—	—	—
DMA2REQ	0B22	FORCE	—	—	—	—	—	—	—	IRQSEL7	IRQSEL6	IRQSEL5	AMODE0	IRQSEL3	IRQS
DMA2STAL	0B24	—	—	—	—	—	—	—	—	—	—	—	—	—	—
DMA2STAH	0B26	—	—	—	—	—	—	—	—	—	—	—	—	—	—
DMA2STBL	0B28	—	—	—	—	—	—	—	—	—	—	—	—	—	—
DMA2STBH	0B2A	—	—	—	—	—	—	—	—	—	—	—	—	—	—
DMA2PAD	0B2C	—	—	—	—	—	—	—	—	—	—	—	—	—	—
DMA2CNT	0B2E	—	—	—	—	—	—	—	—	—	—	—	—	—	—
DMA3CON	0B30	CHEN	SIZE	DIR	HALF	NULLW	—	—	—	—	—	—	—	—	—
DMA3REQ	0B32	FORCE	—	—	—	—	—	—	—	IRQSEL7	IRQSEL6	IRQSEL5	AMODE0	IRQSEL3	IRQS
DMA3STAL	0B34	—	—	—	—	—	—	—	—	—	—	—	—	—	—
DMA3STAH	0B36	—	—	—	—	—	—	—	—	—	—	—	—	—	—
DMA3STBL	0B38	—	—	—	—	—	—	—	—	—	—	—	—	—	—
DMA3STBH	0B3A	—	—	—	—	—	—	—	—	—	—	—	—	—	—
DMA3PAD	0B3C	—	—	—	—	—	—	—	—	—	—	—	—	—	—
DMA3CNT	0B3E	—	—	—	—	—	—	—	—	—	—	—	—	—	—
DMA3WC	0BF0	—	—	—	—	—	—	—	—	—	—	—	—	PWCOL3	PWC
DMA3RQC	0BF2	—	—	—	—	—	—	—	—	—	—	—	—	RQCOL3	RQC
DMA3PPS	0BF4	—	—	—	—	—	—	—	—	—	—	—	—	PPST3	PPS
DMA3LCA	0BF6	—	—	—	—	—	—	—	—	—	—	—	—	L3	LS
DSADR1	0BF8	—	—	—	—	—	—	—	—	—	—	—	—	—	—
DSADRH	0BFA	—	—	—	—	—	—	—	—	—	—	—	—	—	—

Legend: — = unimplemented, read as '0'. Reset values are shown in hexadecimal.

TABLE 4-46: PORTA REGISTER MAP FOR dsPIC33EPXXXGM310/710 DEVICES

SFR Name	Addr.	Bit 15	Bit 14	Bit 13	Bit 12	Bit 11	Bit 10	Bit 9	Bit 8	Bit 7	Bit 6	Bit 5	Bit 4	Bit 3	Bit 2
TRISA	0E00	TRISA<15:14>	—	—	—	—	TRISA<12:7>	—	—	—	—	—	TRISA4	—	—
PORTA	0E02	RA<15:14>	—	—	—	—	RA<12:7>	—	—	—	—	—	RA4	—	—
LATA	0E04	LATA<15:14>	—	—	—	—	LATA<12:7>	—	—	—	—	—	LATA4	—	—
ODCA	0E06	ODCA<15:14>	—	—	—	—	ODCA<12:7>	—	—	—	—	—	ODCA4	—	—
CNENA	0E08	CNIEA<15:14>	—	—	—	—	CNIEA<12:7>	—	—	—	—	—	CNIEA4	—	—
CNPUA	0E0A	CNPJA<15:14>	—	—	—	—	CNPJA<12:7>	—	—	—	—	—	CNPJA4	—	—
CNPDA	0E0C	CNPDA<15:14>	—	—	—	—	CNPDA<12:7>	—	—	—	—	—	CNPDA4	—	—
ANSELA	0E0E	ANSA<15:14>	—	—	—	—	ANSA9	—	—	—	—	—	ANSA4	—	—

Legend: — = unimplemented, read as '0'. Reset values are shown in hexadecimal.

TABLE 4-47: PORTA REGISTER MAP FOR dsPIC33EPXXXGM306/706 DEVICES

SFR Name	Addr.	Bit 15	Bit 14	Bit 13	Bit 12	Bit 11	Bit 10	Bit 9	Bit 8	Bit 7	Bit 6	Bit 5	Bit 4	Bit 3	Bit 2
TRISA	0E00	—	—	—	—	—	TRISA<12:7>	—	—	—	—	—	TRISA4	—	—
PORTA	0E02	—	—	—	—	—	RA<12:7>	—	—	—	—	—	RA4	—	—
LATA	0E04	—	—	—	—	—	LATA<12:7>	—	—	—	—	—	LATA4	—	—
ODCA	0E06	—	—	—	—	—	ODCA<12:7>	—	—	—	—	—	ODCA4	—	—
CNENA	0E08	—	—	—	—	—	CNIEA<12:7>	—	—	—	—	—	CNIEA4	—	—
CNPUA	0E0A	—	—	—	—	—	CNPJA<12:7>	—	—	—	—	—	CNPJA4	—	—
CNPDA	0E0C	—	—	—	—	—	CNPDA<12:7>	—	—	—	—	—	CNPDA4	—	—
ANSELA	0E0E	—	—	—	—	—	ANSA<12:11>	—	—	—	—	—	ANSA4	—	—

Legend: — = unimplemented, read as '0'. Reset values are shown in hexadecimal.

TABLE 4-48: PORTA REGISTER MAP FOR dsPIC33EPXXXGM304/604 DEVICES

SFR Name	Addr.	Bit 15	Bit 14	Bit 13	Bit 12	Bit 11	Bit 10	Bit 9	Bit 8	Bit 7	Bit 6	Bit 5	Bit 4	Bit 3	Bit 2
TRISA	0E00	—	—	—	—	—	TRISA<10:7>	TRISA<10:7>	—	—	—	—	TRISA<4>	—	TRISA<2>
PORTA	0E02	—	—	—	—	—	RA<10:7>	RA<10:7>	—	—	—	—	RA<4>	—	RA<2>
LATA	0E04	—	—	—	—	—	LATA<10:7>	LATA<10:7>	—	—	—	—	LATA<4>	—	LATA<2>
ODCA	0E06	—	—	—	—	—	ODCA<10:7>	ODCA<10:7>	—	—	—	—	ODCA<4>	—	ODCA<2>
CNENA	0E08	—	—	—	—	—	CNIEA<10:7>	CNIEA<10:7>	—	—	—	—	CNIEA<4>	—	CNIEA<2>
CNPUA	0E0A	—	—	—	—	—	CNPJA<10:7>	CNPJA<10:7>	—	—	—	—	CNPJA<4>	—	CNPJA<2>
CNPDA	0E0C	—	—	—	—	—	CNPDA<10:7>	CNPDA<10:7>	—	—	—	—	CNPDA<4>	—	CNPDA<2>
ANSELA	0E0E	—	—	—	—	—	ANSA9	ANSA9	—	—	—	—	ANSA4	—	ANSA2

Legend: — = unimplemented, read as '0'. Reset values are shown in hexadecimal.

TABLE 4-49: PORTB REGISTER MAP FOR dsPIC33EPXXGM310/710 DEVICES

SFR Name	Addr.	Bit 15	Bit 14	Bit 13	Bit 12	Bit 11	Bit 10	Bit 9	Bit 8	Bit 7	Bit 6	Bit 5	Bit 4	Bit 3	Bit 2	
TRISB	0E10	TRISB<15:0>														
PORTB	0E12	RB<15:0>														
LATB	0E14	LATB<15:0>														
ODCB	0E16	ODCB<15:0>														
CNENB	0E18	CNIEB<15:0>														
CNPUB	0E1A	CNPUB<15:0>														
CNPDB	0E1C	CNPDB<15:0>														
ANSELB	0E1E	—	—	—	—	—	—	—	—	—	—	—	—	—	AN	

Legend: x = unknown value on Reset; — = unimplemented, read as '0'. Reset values are shown in hexadecimal.

TABLE 4-50: PORTB REGISTER MAP FOR dsPIC33EPXXGM306/706 DEVICES

SFR Name	Addr.	Bit 15	Bit 14	Bit 13	Bit 12	Bit 11	Bit 10	Bit 9	Bit 8	Bit 7	Bit 6	Bit 5	Bit 4	Bit 3	Bit 2	
TRISB	0E10	TRISB<15:0>														
PORTB	0E12	RB<15:0>														
LATB	0E14	LATB<15:0>														
ODCB	0E16	ODCB<15:0>														
CNENB	0E18	CNIEB<15:0>														
CNPUB	0E1A	CNPUB<15:0>														
CNPDB	0E1C	CNPDB<15:0>														
ANSELB	0E1E	—	—	—	—	—	—	—	—	—	—	—	—	—	AN	

Legend: x = unknown value on Reset; — = unimplemented, read as '0'. Reset values are shown in hexadecimal.

TABLE 4-51: PORTB REGISTER MAP FOR dsPIC33EPXXGM304/604 DEVICES

SFR Name	Addr.	Bit 15	Bit 14	Bit 13	Bit 12	Bit 11	Bit 10	Bit 9	Bit 8	Bit 7	Bit 6	Bit 5	Bit 4	Bit 3	Bit 2	
TRISB	0E10	TRISB<15:0>														
PORTB	0E12	RB<15:0>														
LATB	0E14	LATB<15:0>														
ODCB	0E16	ODCB<15:0>														
CNENB	0E18	CNIEB<15:0>														
CNPUB	0E1A	CNPUB<15:0>														
CNPDB	0E1C	CNPDB<15:0>														
ANSELB	0E1E	—	—	—	—	—	—	—	—	—	—	—	—	—	AN	

Legend: x = unknown value on Reset; — = unimplemented, read as '0'. Reset values are shown in hexadecimal.

TABLE 4-52: PORTC REGISTER MAP FOR dsPIC33EPXXXGM310/710 DEVICES

SFR Name	Addr.	Bit 15	Bit 14	Bit 13	Bit 12	Bit 11	Bit 10	Bit 9	Bit 8	Bit 7	Bit 6	Bit 5	Bit 4	Bit 3	Bit 2
TRISC	0E20	TRISC15	—	—	—	—	—	—	—	—	—	—	—	—	—
PORTC	0E22	RC15	—	—	—	—	—	—	—	—	—	—	—	—	—
LATC	0E24	LATC15	—	—	—	—	—	—	—	—	—	—	—	—	—
ODCC	0E26	ODCC15	—	—	—	—	—	—	—	—	—	—	—	—	—
CNENC	0E28	CNIEC15	—	—	—	—	—	—	—	—	—	—	—	—	—
CNPUC	0E2A	CNPUC15	—	—	—	—	—	—	—	—	—	—	—	—	—
CNPDC	0E2C	CNPDC15	—	—	—	—	—	—	—	—	—	—	—	—	—
ANSEL	0E2E	—	—	—	—	ANSC<12:10>	—	—	—	—	—	—	—	—	ANSC<5:0>

Legend: x = unknown value on Reset; — = unimplemented, read as '0'. Reset values are shown in hexadecimal.

TABLE 4-53: PORTC REGISTER MAP FOR dsPIC33EPXXXGM306/706 DEVICES

SFR Name	Addr.	Bit 15	Bit 14	Bit 13	Bit 12	Bit 11	Bit 10	Bit 9	Bit 8	Bit 7	Bit 6	Bit 5	Bit 4	Bit 3	Bit 2
TRISC	0E20	TRISC15	—	—	—	—	—	—	—	—	—	—	—	—	—
PORTC	0E22	RC15	—	—	—	—	—	—	—	—	—	—	—	—	—
LATC	0E24	LATC15	—	—	—	—	—	—	—	—	—	—	—	—	—
ODCC	0E26	ODCC15	—	—	—	—	—	—	—	—	—	—	—	—	—
CNENC	0E28	CNIEC15	—	—	—	—	—	—	—	—	—	—	—	—	—
CNPUC	0E2A	CNPUC15	—	—	—	—	—	—	—	—	—	—	—	—	—
CNPDC	0E2C	CNPDC15	—	—	—	—	—	—	—	—	—	—	—	—	—
ANSEL	0E2E	—	—	—	—	—	—	—	—	—	—	—	—	—	ANSC<5:0>

Legend: x = unknown value on Reset; — = unimplemented, read as '0'. Reset values are shown in hexadecimal.

TABLE 4-54: PORTC REGISTER MAP FOR dsPIC33EPXXXGM304/604 DEVICES

SFR Name	Addr.	Bit 15	Bit 14	Bit 13	Bit 12	Bit 11	Bit 10	Bit 9	Bit 8	Bit 7	Bit 6	Bit 5	Bit 4	Bit 3	Bit 2
TRISC	0E20	—	—	—	—	—	—	—	—	—	—	—	—	—	—
PORTC	0E22	—	—	—	—	—	—	—	—	—	—	—	—	—	—
LATC	0E24	—	—	—	—	—	—	—	—	—	—	—	—	—	—
ODCC	0E26	—	—	—	—	—	—	—	—	—	—	—	—	—	—
CNENC	0E28	—	—	—	—	—	—	—	—	—	—	—	—	—	—
CNPUC	0E2A	—	—	—	—	—	—	—	—	—	—	—	—	—	—
CNPDC	0E2C	—	—	—	—	—	—	—	—	—	—	—	—	—	—
ANSEL	0E2E	—	—	—	—	—	—	—	—	—	—	—	—	—	ANSC<5:0>

Legend: x = unknown value on Reset; — = unimplemented, read as '0'. Reset values are shown in hexadecimal.

TABLE 4-55: PORTD REGISTER MAP FOR dsPIC33EPXXXGM310/710 DEVICES

SFR Name	Addr.	Bit 15	Bit 14	Bit 13	Bit 12	Bit 11	Bit 10	Bit 9	Bit 8	Bit 7	Bit 6	Bit 5	Bit 4	Bit 3	Bit 2
TRISD	0E30	TRISD<15:12>							TRISD8		TRISD<6:1>				
PORTD	0E32	RD<15:12>							RD8		RD<6:1>				
LATD	0E34	LATD<15:12>							LATD8		LATD<6:1>				
ODCD	0E36	ODCD<15:12>							ODCD8		ODCD<6:1>				
CNIEND	0E38	CNIEND<15:12>							CNIED8		CNIED<6:1>				
CNPUD	0E3A	CNPUD<15:12>							CNPUD8		CNPUD<6:1>				
CNPDD	0E3C	CNPDD<15:12>							CNPDD8		CNPDD<6:1>				
ANSELD	0E3E	ANSD<15:14>													

Legend: x = unknown value on Reset; — = unimplemented, read as '0'. Reset values are shown in hexadecimal.

TABLE 4-56: PORTD REGISTER MAP FOR dsPIC33EPXXXGM306/706 DEVICES

SFR Name	Addr.	Bit 15	Bit 14	Bit 13	Bit 12	Bit 11	Bit 10	Bit 9	Bit 8	Bit 7	Bit 6	Bit 5	Bit 4	Bit 3	Bit 2
TRISD	0E30								TRISD8		TRISD<6:5>				
PORTD	0E32								RD8		RD<6:5>				
LATD	0E34								LATD8		LATD<6:5>				
ODCD	0E36								ODCD8		ODCD<6:5>				
CNIEND	0E38								CNIED8		CNIED<6:5>				
CNPUD	0E3A								CNPUD8		CNPUD<6:5>				
CNPDD	0E3C														

Legend: x = unknown value on Reset; — = unimplemented, read as '0'. Reset values are shown in hexadecimal.

TABLE 4-57: PORTE REGISTER MAP FOR dsPIC33EPXXXGM310/710 DEVICES

SFR Name	Addr.	Bit 15	Bit 14	Bit 13	Bit 12	Bit 11	Bit 10	Bit 9	Bit 8	Bit 7	Bit 6	Bit 5	Bit 4	Bit 3	Bit 2
TRISE	0E40	TRISE<15:12>							TRISE<9:8>						
PORTE	0E42	RE<15:12>							RE<9:8>						
LATE	0E44	LATE<15:12>							LATE<9:8>						
ODCE	0E46	ODCE<15:12>							ODCE<9:8>						
CNIENE	0E48	CNIEE<15:12>							CNIEE<9:8>						
CNPUE	0E4A	CNPUE<15:12>							CNPUE<9:8>						
CNPDE	0E4C	CNPDE<15:12>							CNPDE<9:8>						
ANSELE	0E4E	ANSE<15:12>							ANSE<9:8>						

Legend: x = unknown value on Reset; — = unimplemented, read as '0'. Reset values are shown in hexadecimal.

TABLE 4-58: PORTE REGISTER MAP FOR dsPIC33EPXXXGM306/706 DEVICES

SFR Name	Addr.	Bit 15	Bit 14	Bit 13	Bit 12	Bit 11	Bit 10	Bit 9	Bit 8	Bit 7	Bit 6	Bit 5	Bit 4	Bit 3	Bit 2
TRISE	0E40	TRISE<15:12>													
PORTE	0E42	RE<15:12>													
LATE	0E44	LATE<15:12>													
ODCE	0E46	ODCE<15:12>													
CNENE	0E48	CNIEE<15:12>													
CNPUE	0E4A	CNPUE<15:12>													
CNPDE	0E4C	CNPDE<15:12>													
ANSELE	0E4E	ANSE<15:12>													

Legend: x = unknown value on Reset; — = unimplemented, read as '0'. Reset values are shown in hexadecimal.

TABLE 4-59: PORTF REGISTER MAP FOR dsPIC33EPXXXGM310/710 DEVICES

SFR Name	Addr.	Bit 15	Bit 14	Bit 13	Bit 12	Bit 11	Bit 10	Bit 9	Bit 8	Bit 7	Bit 6	Bit 5	Bit 4	Bit 3	Bit 2
TRISF	0E50	—	—	TRISF<13:12>		—	TRISF<10:9>		—	TRISF<7:4>		—	—	—	—
PORTF	0E52	—	—	RF<13:12>		—	RF<10:9>		—	RF<7:4>		—	—	—	—
LATF	0E54	—	—	LATF<13:12>		—	LATF<10:9>		—	LATF<7:4>		—	—	—	—
ODCF	0E56	—	—	ODCF<13:12>		—	ODCF<10:9>		—	ODCF<7:4>		—	—	—	—
CNENF	0E58	—	—	CNIEF<13:12>		—	CNIEF<10:9>		—	CNIEF<7:4>		—	—	—	—
CNPUF	0E5A	—	—	CNPUF<13:12>		—	CNPUF<10:9>		—	CNPUF<7:4>		—	—	—	—
CNPDF	0E5C	—	—	CNPDF<13:12>		—	CNPDF<10:9>		—	CNPDF<7:4>		—	—	—	—
ANSELF	0E4E	—	—	ANSF<13:12>		—	ANSF<10:9>		—	ANSF<5:4>		—	—	—	—

Legend: x = unknown value on Reset; — = unimplemented, read as '0'. Reset values are shown in hexadecimal.

TABLE 4-60: PORTF REGISTER MAP FOR dsPIC33EPXXXGM306/706 DEVICES

SFR Name	Addr.	Bit 15	Bit 14	Bit 13	Bit 12	Bit 11	Bit 10	Bit 9	Bit 8	Bit 7	Bit 6	Bit 5	Bit 4	Bit 3	Bit 2
TRISF	0E50	—	—	—	—	—	—	—	—	—	—	—	—	—	—
PORTF	0E52	—	—	—	—	—	—	—	—	—	—	—	—	—	—
LATF	0E54	—	—	—	—	—	—	—	—	—	—	—	—	—	—
ODCF	0E56	—	—	—	—	—	—	—	—	—	—	—	—	—	—
CNENF	0E58	—	—	—	—	—	—	—	—	—	—	—	—	—	—
CNPUF	0E5A	—	—	—	—	—	—	—	—	—	—	—	—	—	—
CNPDF	0E5C	—	—	—	—	—	—	—	—	—	—	—	—	—	—

Legend: x = unknown value on Reset; — = unimplemented, read as '0'. Reset values are shown in hexadecimal.

TABLE 4-61: PORTG REGISTER MAP FOR dsPIC33EPXXGM310/710 DEVICES

SFR Name	Addr.	Bit 15	Bit 14	Bit 13	Bit 12	Bit 11	Bit 10	Bit 9	Bit 8	Bit 7	Bit 6	Bit 5	Bit 4	Bit 3	Bit
TRISG	0E60	TRISG<15:6>													
PORTG	0E62	RG<15:6>													
LATG	0E64	LATG<15:6>													
ODCG	0E66	ODCG<15:6>													
CNENG	0E68	CNIEG<15:6>													
CNPUG	0E6A	CNPUG<15:6>													
CNPDG	0E6C	CNPDG<15:6>													
ANSELG	0E6E	ANSG15	—	—	—	—	—	—	—	—	—	—	—	—	ANSG<3:2>

Legend: x = unknown value on Reset, — = unimplemented, read as '0'. Reset values are shown in hexadecimal.

TABLE 4-62: PORTG REGISTER MAP FOR dsPIC33EPXXGM306/706 DEVICES

SFR Name	Addr.	Bit 15	Bit 14	Bit 13	Bit 12	Bit 11	Bit 10	Bit 9	Bit 8	Bit 7	Bit 6	Bit 5	Bit 4	Bit 3	Bit
TRISG	0E60	—	—	—	—	—	—	—	—	TRISG<9:6>	—	—	—	—	—
PORTG	0E62	—	—	—	—	—	—	—	—	RG<9:6>	—	—	—	—	—
LATG	0E64	—	—	—	—	—	—	—	—	LATG<9:6>	—	—	—	—	—
ODCG	0E66	—	—	—	—	—	—	—	—	ODCG<9:6>	—	—	—	—	—
CNENG	0E68	—	—	—	—	—	—	—	—	CNIEG<9:6>	—	—	—	—	—
CNPUG	0E6A	—	—	—	—	—	—	—	—	CNPUG<9:6>	—	—	—	—	—
CNPDG	0E6C	—	—	—	—	—	—	—	—	CNPDG<9:6>	—	—	—	—	—
ANSELG	0E6E	—	—	—	—	—	—	—	—	ANSG<9:6>	—	—	—	—	—

Legend: x = unknown value on Reset, — = unimplemented, read as '0'. Reset values are shown in hexadecimal.

TABLE 4-63: PAD CONFIGURATION REGISTER MAP

File Name	Addr.	Bit 15	Bit 14	Bit 13	Bit 12	Bit 11	Bit 10	Bit 9	Bit 8	Bit 7	Bit 6	Bit 5	Bit 4	Bit 3	Bit 2
PADCFG1	0EFE	—	—	—	—	—	—	—	—	—	—	—	—	—	—

Legend: — = unimplemented, read as '0'. Reset values are shown in hexadecimal.

dsPIC33EPXXXGM3XX/6XX/7XX

4.3.1 PAGED MEMORY SCHEME

The dsPIC33EPXXXGM3XX/6XX/7XX architecture extends the available Data Space through a paging scheme, which allows the available Data Space to be accessed using MOV instructions in a linear fashion for pre- and post-modified Effective Addresses (EA). The upper half of the Base Data Space address is used in conjunction with the Data Space Page registers, the 10-bit Data Space Read Page register (DSRPAG) or the 9-bit Data Space Write Page register (DSWPAG), to form an Extended Data Space (EDS) address, or Program Space Visibility (PSV) address. The Data Space Page registers are located in the SFR space.

Construction of the EDS address is shown in Figure 4-8. When DSRPAG<9> = 0 and the base address bit, EA<15> = 1, the DSRPAG<8:0> bits are concatenated onto EA<14:0> to form the 24-bit EDS read address. Similarly, when the base address bit, EA<15> = 1, the DSWPAG<8:0> bits are concatenated onto EA<14:0> to form the 24-bit EDS write address.

FIGURE 4-8: EXTENDED DATA SPACE (EDS) READ ADDRESS GENERATION

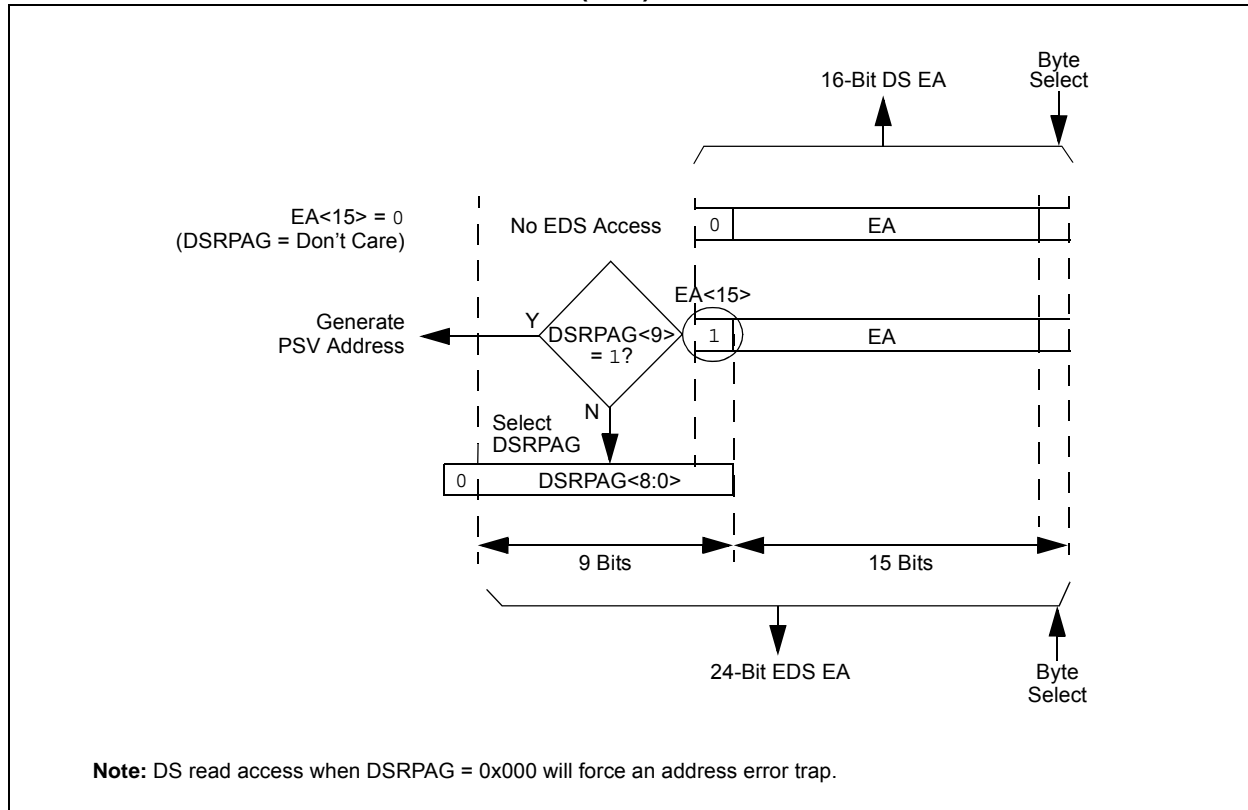
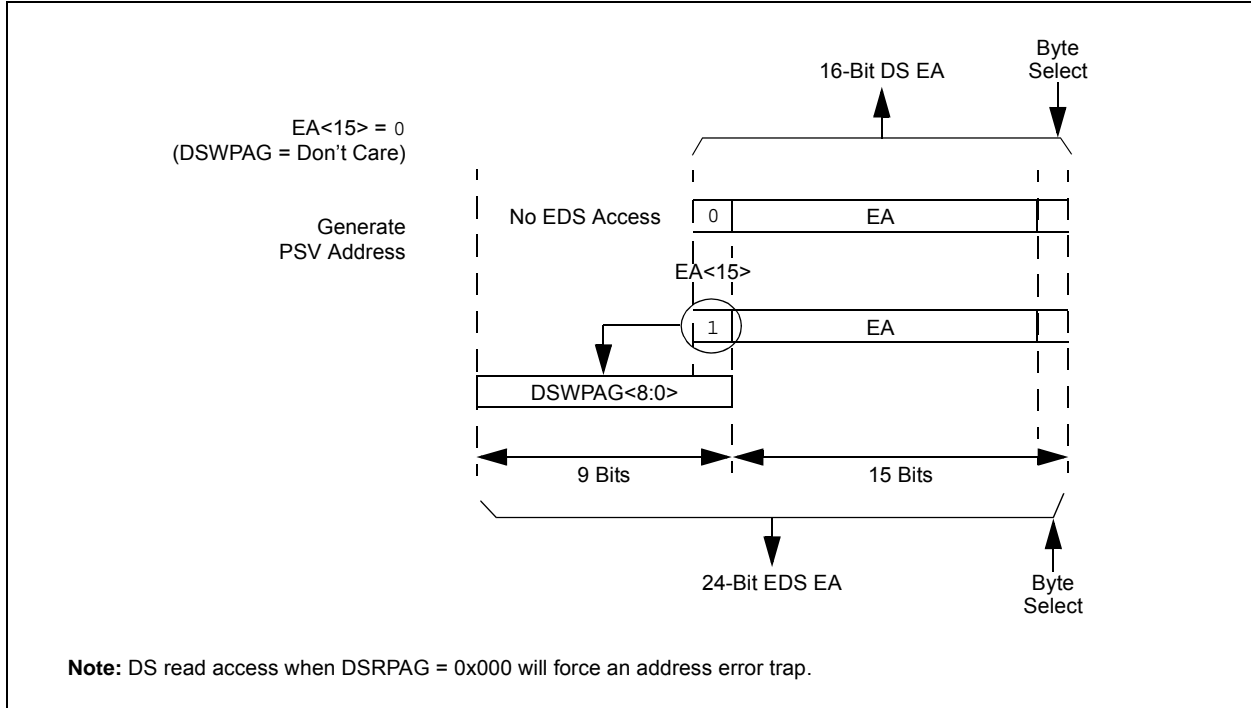

FIGURE 4-9: EXTENDED DATA SPACE (EDS) WRITE ADDRESS GENERATION



The paged memory scheme provides access to multiple 32-Kbyte windows in the EDS and PSV memory. The Data Space Page registers, DSxPAG, in combination with the upper half of the Data Space address, can provide up to 16 Mbytes of additional address space in the EDS and 8 Mbytes (DSRPAG only) of PSV address space. The paged data memory space is shown in [Figure 4-10](#).

The Program Space (PS) can be accessed with a DSRPAG of 0x200 or greater. Only reads from PS are supported using the DSRPAG. Writes to PS are not supported, so DSWPAG is dedicated to DS, including EDS only. The Data Space and EDS can be read from, and written to, using DSRPAG and DSWPAG, respectively.

FIGURE 4-10: PAGED DATA MEMORY SPACE

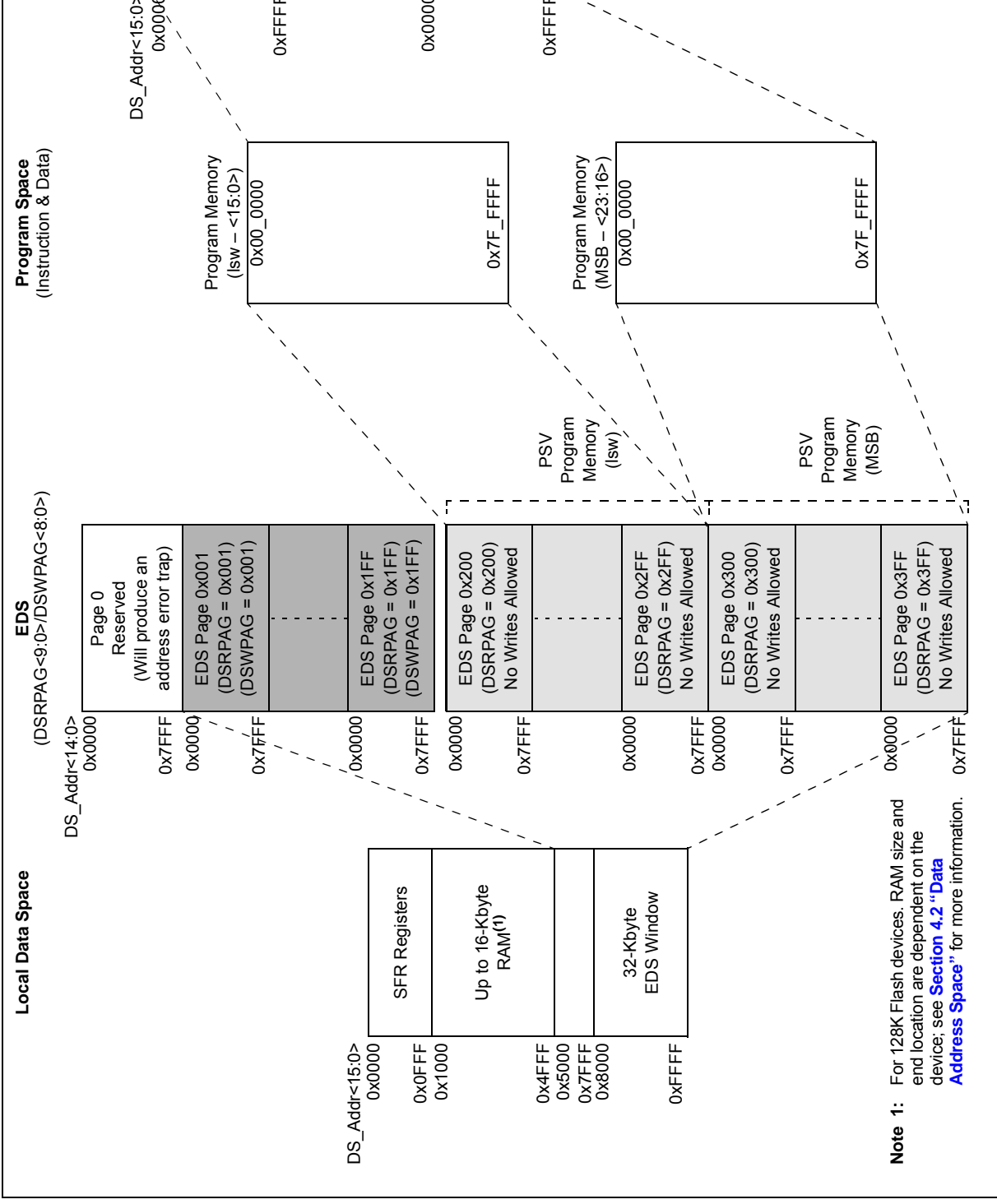

dsPIC33EPXXXGM3XX/6XX/7XX

Allocating different Page registers for read and write access allows the architecture to support data movement between different pages in data memory. This is accomplished by setting the DSRPAG register value to the page from which you want to read and configuring the DSWPAG register to the page to which it needs to be written. Data can also be moved from different PSV to EDS pages by configuring the DSRPAG and DSWPAG registers to address PSV and EDS space, respectively. The data can be moved between pages by a single instruction.

When an EDS or PSV page overflow or underflow occurs, EA<15> is cleared as a result of the register indirect EA calculation. An overflow or underflow of the EA in the EDS or PSV pages can occur at the page boundaries when:

- The initial address, prior to modification, addresses an EDS or PSV page
- The EA calculation uses Pre- or Post-Modified Register Indirect Addressing. However, this does not include Register Offset Addressing

In general, when an overflow is detected, the DSxPAG register is incremented and the EA<15> bit is set to keep the base address within the EDS or PSV window. When an underflow is detected, the DSxPAG register is decremented and the EA<15> bit is set to keep the base address within the EDS or PSV window. This creates a linear EDS and PSV address space, but only when using Register Indirect Addressing modes.

Exceptions to the operation described above arise when entering and exiting the boundaries of Page 0, EDS and PSV spaces. [Table 4-64](#) lists the effects of overflow and underflow scenarios at different boundaries.

In the following cases, when overflow or underflow occurs, the EA<15> bit is set and the DSxPAG is not modified; therefore, the EA will wrap to the beginning of the current page:

- Register Indirect with Register Offset Addressing
- Modulo Addressing
- Bit-Reversed Addressing

TABLE 4-64: OVERFLOW AND UNDERFLOW SCENARIOS AT PAGE 0, EDS AND PSV SPACE BOUNDARIES^(2,3,4)

O/U, R/W	Operation	Before			After		
		DSxPAG	DS EA<15>	Page Description	DSxPAG	DS EA<15>	Page Description
O, Read	[++Wn] or [Wn++]	DSRPAG = 0x1FF	1	EDS: Last Page	DSRPAG = 0x1FF	0	See Note 1
O, Read		DSRPAG = 0x2FF	1	PSV: Last lsw Page	DSRPAG = 0x300	1	PSV: First MSB Page
O, Read		DSRPAG = 0x3FF	1	PSV: Last MSB Page	DSRPAG = 0x3FF	0	See Note 1
O, Write		DSWPAG = 0x1FF	1	EDS: Last Page	DSWPAG = 0x1FF	0	See Note 1
U, Read	[--Wn] or [Wn--]	DSRPAG = 0x001	1	PSV Page	DSRPAG = 0x001	0	See Note 1
U, Read		DSRPAG = 0x200	1	PSV: First lsw Page	DSRPAG = 0x200	0	See Note 1
U, Read		DSRPAG = 0x300	1	PSV: First MSB Page	DSRPAG = 0x2FF	1	PSV: Last lsw Page

Legend: O = Overflow, U = Underflow, R = Read, W = Write

- Note 1:** The Register Indirect Addressing now addresses a location in the Base Data Space (0x0000-0x8000).
- 2:** An EDS access with DSxPAG = 0x000 will generate an address error trap.
- 3:** Only reads from PS are supported using DSRPAG. An attempt to write to PS using DSWPAG will generate an address error trap.
- 4:** Pseudo Linear Addressing is not supported for large offsets.

dsPIC33EPXXXGM3XX/6XX/7XX

4.3.2 EXTENDED X DATA SPACE

The lower portion of the base address space range, between 0x0000 and 0x7FFF, is always accessible regardless of the contents of the Data Space Page registers. It is indirectly addressable through the register indirect instructions. It can be regarded as being located in the default EDS Page 0 (i.e., EDS address range of 0x000000 to 0x007FFF with the base address bit, EA<15> = 0, for this address range). However, Page 0 cannot be accessed through the upper 32 Kbytes, 0x8000 to 0xFFFF, of Base Data Space, in combination with DSRPAG = 0x000 or DSWPAG = 0x000. Consequently, DSRPAG and DSWPAG are initialized to 0x001 at Reset.

Note 1: DSxPAG should not be used to access Page 0. An EDS access with DSxPAG set to 0x000 will generate an address error trap.

2: Clearing the DSxPAG in software has no effect.

The remaining pages, including both EDS and PSV pages, are only accessible using the DSRPAG or DSWPAG register, in combination with the upper 32 Kbytes, 0x8000 to 0xFFFF, of the base address, where the base address bit, EA<15> = 1.

For example, when DSRPAG = 0x001 or DSWPAG = 0x001, accesses to the upper 32 Kbytes, 0x8000 to 0xFFFF, of the Data Space will map to the EDS address range of 0x008000 to 0x00FFFF. When DSRPAG = 0x002 or DSWPAG = 0x002, accesses to the upper 32 Kbytes of the Data Space will map to the EDS address range of 0x010000 to 0x017FFF and so on, as shown in the EDS memory map in [Figure 4-11](#).

For more information on the PSV page access, using Data Space Page registers, refer to the “**Program Space Visibility from Data Space**” section in “**Program Memory**” (DS70613) of the “*dsPIC33/PIC24 Family Reference Manual*”.

FIGURE 4-11: EDS MEMORY MAP

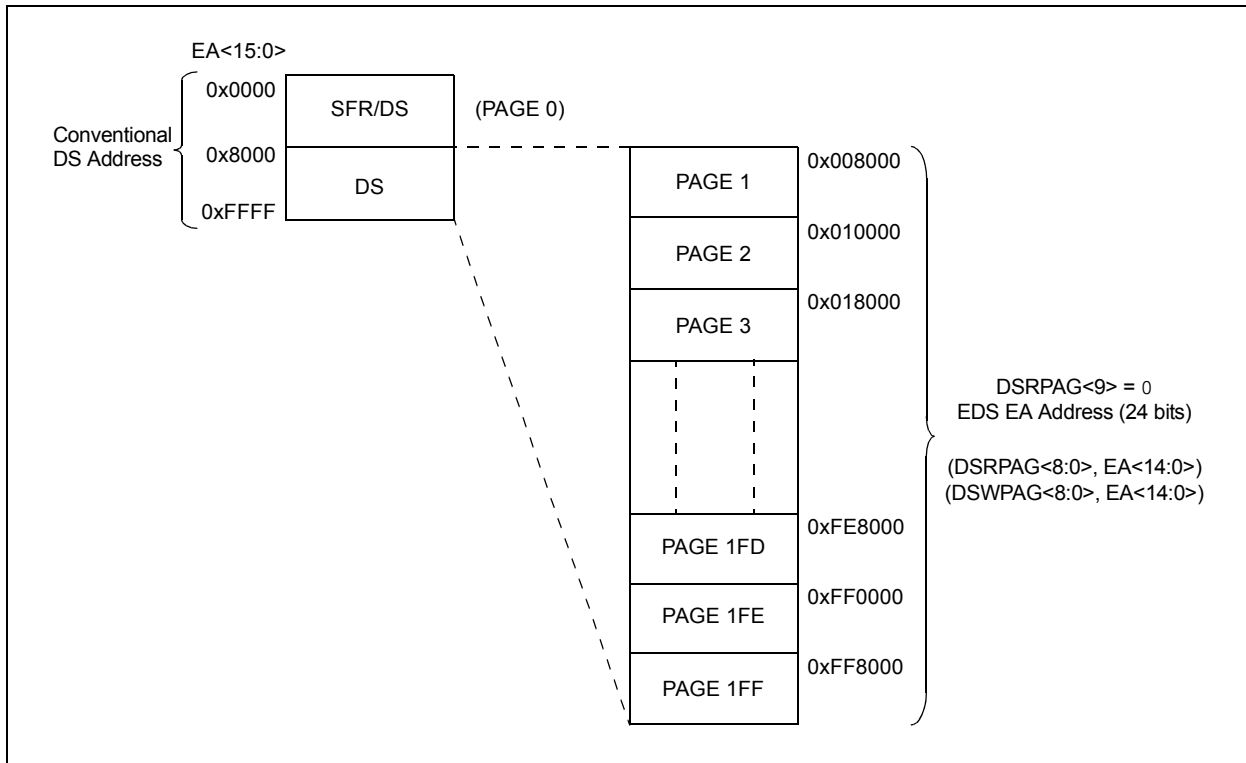

4.3.3 DATA MEMORY ARBITRATION AND BUS MASTER PRIORITY

EDS accesses from bus masters in the system are arbitrated.

The arbiter for data memory (including EDS) arbitrates between the CPU, the DMA and the ICD module. In the event of coincidental access to a bus by the bus masters, the arbiter determines which bus master access has the highest priority. The other bus masters are suspended and processed after the access of the bus by the bus master with the highest priority.

By default, the CPU is Bus Master 0 (M0) with the highest priority and the ICD is Bus Master 4 (M4) with the lowest priority. The remaining bus master (DMA Controller) is allocated to M3 (M1 and M2 are reserved and cannot be used). The user application may raise or lower the priority of the DMA Controller to be above that of the CPU by setting the appropriate bits in the EDS Bus Master Priority Control (MSTRPR) register. All bus masters with raised priorities will maintain the same priority relationship relative to each other (i.e., M1 being highest and M3 being lowest with M2 in between). Also, all the bus masters with priorities below

that of the CPU maintain the same priority relationship relative to each other. The priority schemes for bus masters with different MSTRPR values are tabulated in [Table 4-65](#).

This bus master priority control allows the user application to manipulate the real-time response of the system, either statically during initialization or dynamically in response to real-time events.

TABLE 4-65: DATA MEMORY BUS ARBITER PRIORITY

Priority	MSTRPR<15:0> Bit Setting ⁽¹⁾	
	0x0000	0x0020
M0 (highest)	CPU	DMA
M1	Reserved	CPU
M2	Reserved	Reserved
M3	DMA	Reserved
M4 (lowest)	ICD	ICD

Note 1: All other values of MSTRPR<15:0> are reserved.

FIGURE 4-12: ARBITER ARCHITECTURE

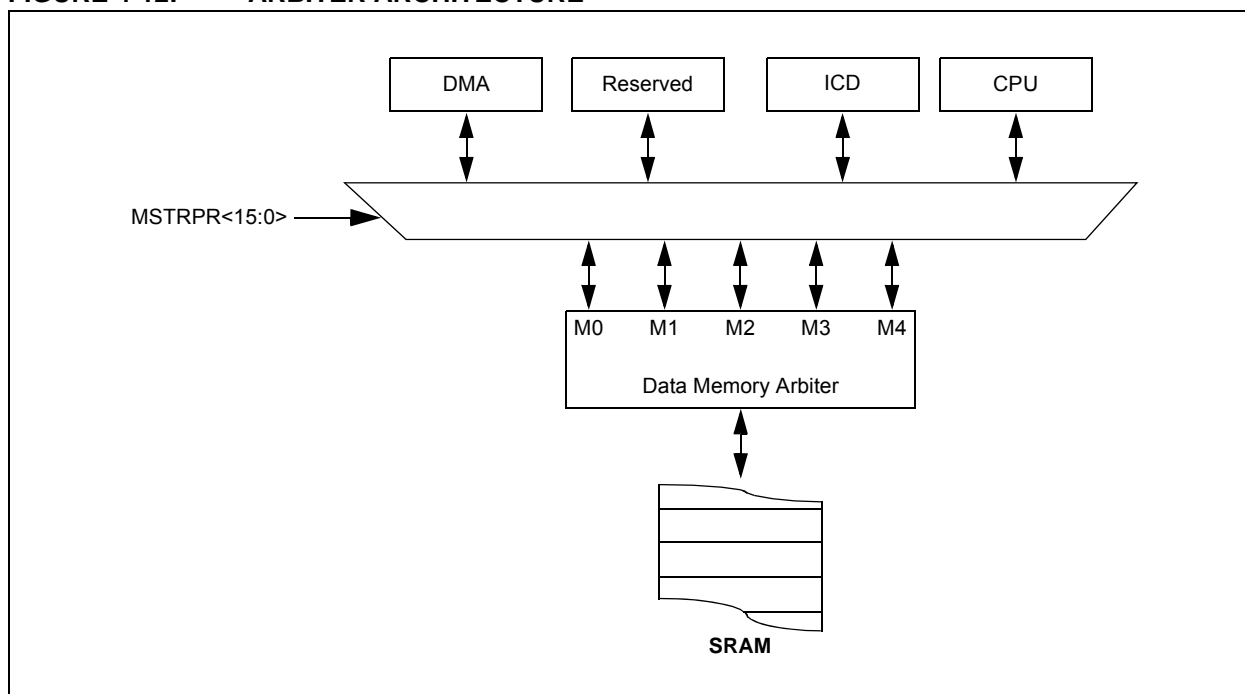

4.3.4 SOFTWARE STACK

The W15 register serves as a dedicated Software Stack Pointer (SSP) and is automatically modified by exception processing, subroutine calls and returns; however, W15 can be referenced by any instruction in the same manner as all other W registers. This simplifies reading, writing and manipulating of the Stack Pointer (for example, creating stack frames).

Note: To protect against misaligned stack accesses, W15<0> is fixed to '0' by the hardware.

W15 is initialized to 0x1000 during all Resets. This address ensures that the SSP points to valid RAM in all dsPIC33EPXXGM3XX/6XX/7XX devices and permits stack availability for non-maskable trap exceptions. These can occur before the SSP is initialized by the user software. You can reprogram the SSP during initialization to any location within Data Space.

The Software Stack Pointer always points to the first available free word and fills the software stack, working from lower toward higher addresses. Figure 4-13 illustrates how it pre-decrements for a stack pop (read) and post-increments for a stack push (writes).

When the PC is pushed onto the stack, PC<15:0> are pushed onto the first available stack word, then PC<22:16> are pushed into the second available stack location. For a PC push during any CALL instruction, the MSB of the PC is zero-extended before the push, as shown in Figure 4-13. During exception processing, the MSB of the PC is concatenated with the lower 8 bits of the CPU STATUS Register, SR. This allows the contents of SRL to be preserved automatically during interrupt processing.

Note 1: To maintain the Software Stack Pointer (W15) coherency, W15 is never subject to (EDS) paging, and is therefore, restricted to an address range of 0x0000 to 0xFFFF. The same applies to the W14 when used as a Stack Frame Pointer (SFA = 1).

2: As the stack can be placed in, and can access X and Y spaces, care must be taken regarding its use, particularly with regard to local automatic variables in a 'C' development environment

FIGURE 4-13: CALL STACK FRAME

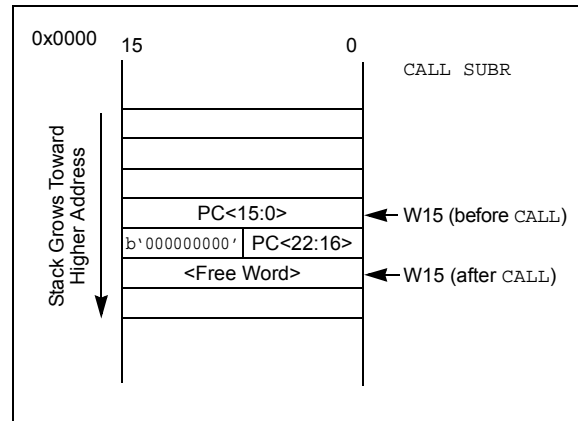

4.4 Instruction Addressing Modes

The addressing modes shown in Table 4-66 form the basis of the addressing modes optimized to support the specific features of the individual instructions. The addressing modes provided in the MAC class of instructions differ from those in the other instruction types.

4.4.1 FILE REGISTER INSTRUCTIONS

Most file register instructions use a 13-bit address field (f) to directly address data present in the first 8192 bytes of data memory (Near Data Space). Most file register instructions employ a Working register, W0, which is denoted as WREG in these instructions. The destination is typically either the same file register or WREG (with the exception of the MUL instruction), which writes the result to a register or register pair. The MOV instruction allows additional flexibility and can access the entire Data Space.

4.4.2 MCU INSTRUCTIONS

The three-operand MCU instructions are of the form:

Operand 3 = Operand 1 <function> Operand 2

where Operand 1 is always a Working register (that is, the addressing mode can only be Register Direct), which is referred to as Wb. Operand 2 can be a W register fetched from data memory or a 5-bit literal. The result location can be either a W register or a data memory location. The following addressing modes are supported by MCU instructions:

- Register Direct
- Register Indirect
- Register Indirect Post-Modified
- Register Indirect Pre-Modified
- 5-Bit or 10-Bit Literal

Note: Not all instructions support all of the addressing modes given above. Individual instructions can support different subsets of these addressing modes.

TABLE 4-66: FUNDAMENTAL ADDRESSING MODES SUPPORTED

Addressing Mode	Description
File Register Direct	The address of the file register is specified explicitly.
Register Direct	The contents of a register are accessed directly.
Register Indirect	The contents of Wn form the Effective Address (EA).
Register Indirect Post-Modified	The contents of Wn form the EA. Wn is post-modified (incremented or decremented) by a constant value.
Register Indirect Pre-Modified	Wn is pre-modified (incremented or decremented) by a signed constant value to form the EA.
Register Indirect with Register Offset (Register Indexed)	The sum of Wn and Wb forms the EA.
Register Indirect with Literal Offset	The sum of Wn and a literal forms the EA.

4.4.3 MOVE AND ACCUMULATOR INSTRUCTIONS

Move instructions and the DSP accumulator class of instructions provide a greater degree of addressing flexibility than other instructions. In addition to the addressing modes supported by most MCU instructions, move and accumulator instructions also support Register Indirect with Register Offset Addressing mode, also referred to as Register Indexed mode.

Note: For the `MOV` instructions, the addressing mode specified in the instruction can differ for the source and destination EA. However, the 4-bit Wb (Register Offset) field is shared by both source and destination (but typically only used by one).

In summary, the following addressing modes are supported by move and accumulator instructions:

- Register Direct
- Register Indirect
- Register Indirect Post-modified
- Register Indirect Pre-modified
- Register Indirect with Register Offset (Indexed)
- Register Indirect with Literal Offset
- 8-Bit Literal
- 16-Bit Literal

Note: Not all instructions support all the addressing modes given above. Individual instructions may support different subsets of these addressing modes.

4.4.4 MAC INSTRUCTIONS

The dual source operand DSP instructions (`CLR`, `ED`, `EDAC`, `MAC`, `MPY`, `MPY.N`, `MOVSAC` and `MSC`), also referred to as `MAC` instructions, use a simplified set of addressing modes to allow the user application to effectively manipulate the Data Pointers through register indirect tables.

The two-source operand prefetch registers must be members of the set {W8, W9, W10, W11}. For data reads, W8 and W9 are always directed to the X RAGU, and W10 and W11 are always directed to the Y AGU. The Effective Addresses generated (before and after modification) must, therefore, be valid addresses within X Data Space for W8 and W9, and Y Data Space for W10 and W11.

Note: Register Indirect with Register Offset Addressing mode is available only for W9 (in X space) and W11 (in Y space).

In summary, the following addressing modes are supported by the `MAC` class of instructions:

- Register Indirect
- Register Indirect Post-Modified by 2
- Register Indirect Post-Modified by 4
- Register Indirect Post-Modified by 6
- Register Indirect with Register Offset (Indexed)

4.4.5 OTHER INSTRUCTIONS

Besides the addressing modes outlined previously, some instructions use literal constants of various sizes. For example, `BRA` (branch) instructions use 16-bit signed literals to specify the branch destination directly, whereas the `DISI` instruction uses a 14-bit unsigned literal field. In some instructions, such as `ULNK`, the source of an operand or result is implied by the opcode itself. Certain operations, such as `NOP`, do not have any operands.

4.5 Modulo Addressing

Modulo Addressing mode is a method of providing an automated means to support circular data buffers using hardware. The objective is to remove the need for software to perform data address boundary checks when executing tightly looped code, as is typical in many DSP algorithms.

Modulo Addressing can operate in either Data or Program Space (since the Data Pointer mechanism is essentially the same for both). One circular buffer can be supported in each of the X (which also provides the pointers into Program Space) and Y Data Spaces. Modulo Addressing can operate on any W Register Pointer. However, it is not advisable to use W14 or W15 for Modulo Addressing since these two registers are used as the Stack Frame Pointer and Stack Pointer, respectively.

In general, any particular circular buffer can be configured to operate in only one direction, as there are certain restrictions on the buffer start address (for incrementing buffers) or end address (for decrementing buffers), based upon the direction of the buffer.

The only exception to the usage restrictions is for buffers that have a power-of-two length. As these buffers satisfy the start and end address criteria, they can operate in a Bidirectional mode (that is, address boundary checks are performed on both the lower and upper address boundaries).

4.5.1 START AND END ADDRESS

The Modulo Addressing scheme requires that a starting and ending address be specified and loaded into the 16-bit Modulo Buffer Address registers: XMODSRT, XMODEND, YMODSRT and YMODEND (see Table 4-1).

Note: Y space Modulo Addressing EA calculations assume word-sized data (LSb of every EA is always clear).

The length of a circular buffer is not directly specified. It is determined by the difference between the corresponding start and end addresses. The maximum possible length of the circular buffer is 32K words (64 Kbytes).

4.5.2 W ADDRESS REGISTER SELECTION

The Modulo and Bit-Reversed Addressing Control register bits, MODCON<15:0>, contain enable flags as well as a W register field to specify the W Address registers. The XWM and YWM fields select the registers that operate with Modulo Addressing:

- If XWM = 1111, X RAGU and X WAGU Modulo Addressing is disabled
- If YWM = 1111, Y AGU Modulo Addressing is disabled

The X Address Space Pointer W register (XWM) to which Modulo Addressing is to be applied is stored in MODCON<3:0> (see Table 4-1). Modulo Addressing is enabled for X Data Space when XWM is set to any value other than '1111' and the XMODEN bit is set (MODCON<15>).

The Y Address Space Pointer W register (YWM) to which Modulo Addressing is to be applied is stored in MODCON<7:4>. Modulo Addressing is enabled for Y Data Space when YWM is set to any value other than '1111' and the YMODEN bit is set (MODCON<14>).

FIGURE 4-14: MODULO ADDRESSING OPERATION EXAMPLE

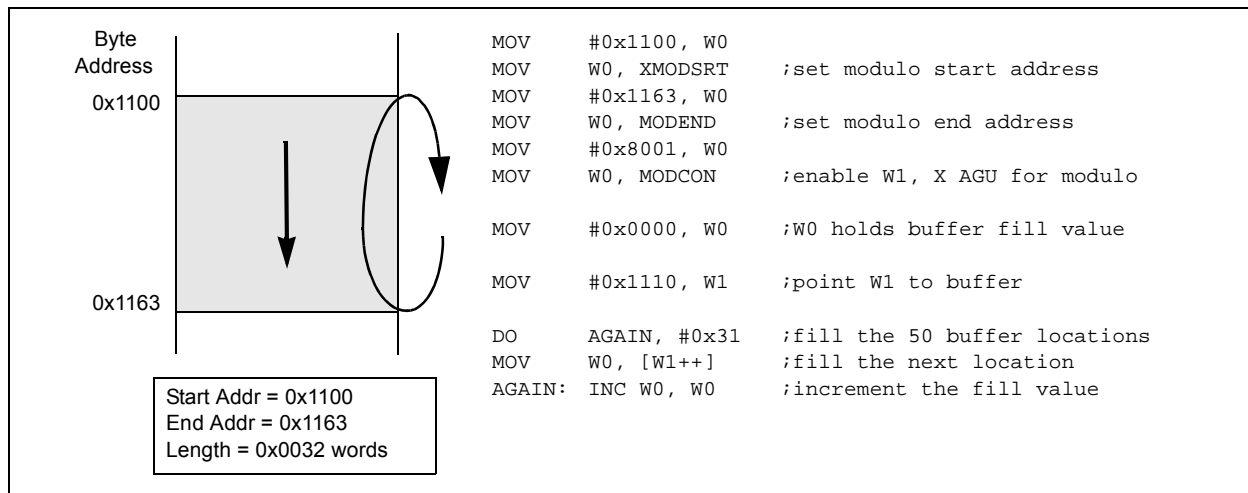

4.5.3 MODULO ADDRESSING APPLICABILITY

Modulo Addressing can be applied to the Effective Address (EA) calculation associated with any W register. Address boundaries check for addresses equal to:

- The upper boundary addresses for incrementing buffers
- The lower boundary addresses for decrementing buffers

It is important to realize that the address boundaries check for addresses less than or greater than the upper (for incrementing buffers) and lower (for decrementing buffers) boundary addresses (not just equal to). Address changes can, therefore, jump beyond boundaries and still be adjusted correctly.

Note: The modulo corrected Effective Address is written back to the register only when Pre-Modify or Post-Modify Addressing mode is used to compute the Effective Address. When an address offset (such as [W7 + W2]) is used, Modulo Addressing correction is performed, but the contents of the register remain unchanged.

4.6 Bit-Reversed Addressing

Bit-Reversed Addressing mode is intended to simplify data reordering for radix-2 FFT algorithms; it is supported by the X AGU for data writes only.

The modifier, which can be a constant value or register contents, is regarded as having its bit order reversed. The address source and destination are kept in normal order. Thus, the only operand requiring reversal is the modifier.

4.6.1 BIT-REVERSED ADDRESSING IMPLEMENTATION

Bit-Reversed Addressing mode is enabled when all of these conditions are met:

- BWM bits (W register selection) in the MODCON register are any value other than '1111' (the stack cannot be accessed using Bit-Reversed Addressing)
- The BREN bit is set in the XBREV register
- The addressing mode used is Register Indirect with Pre-Increment or Post-Increment

If the length of a bit-reversed buffer is $M = 2^N$ bytes, the last 'N' bits of the data buffer start address must be zeros.

$XB<14:0>$ is the Bit-Reversed Addressing modifier, or 'pivot point', which is typically a constant. In the case of an FFT computation, its value is equal to half of the FFT data buffer size.

Note: All bit-reversed EA calculations assume word-sized data (LSb of every EA is always clear). The XB value is scaled accordingly to generate compatible (byte) addresses.

When enabled, Bit-Reversed Addressing is executed only for Register Indirect with Pre-Increment or Post-Increment Addressing and word-sized data writes. It does not function for any other addressing mode or for byte-sized data and normal addresses are generated instead. When Bit-Reversed Addressing is active, the W Address Pointer is always added to the address modifier (XB) and the offset associated with the Register Indirect Addressing mode is ignored. In addition, as word-sized data is a requirement, the LSB of the EA is ignored (and always clear).

Note: Modulo Addressing and Bit-Reversed Addressing can be enabled simultaneously using the same W register, but Bit-Reversed Addressing operation will always take precedence for data writes when enabled.

If Bit-Reversed Addressing has already been enabled by setting the BREN (XBREV<15>) bit, a write to the XBREV register should not be immediately followed by an indirect read operation using the W register that has been designated as the Bit-Reversed Pointer.

dsPIC33EPXXXGM3XX/6XX/7XX

FIGURE 4-15: BIT-REVERSED ADDRESSING EXAMPLE

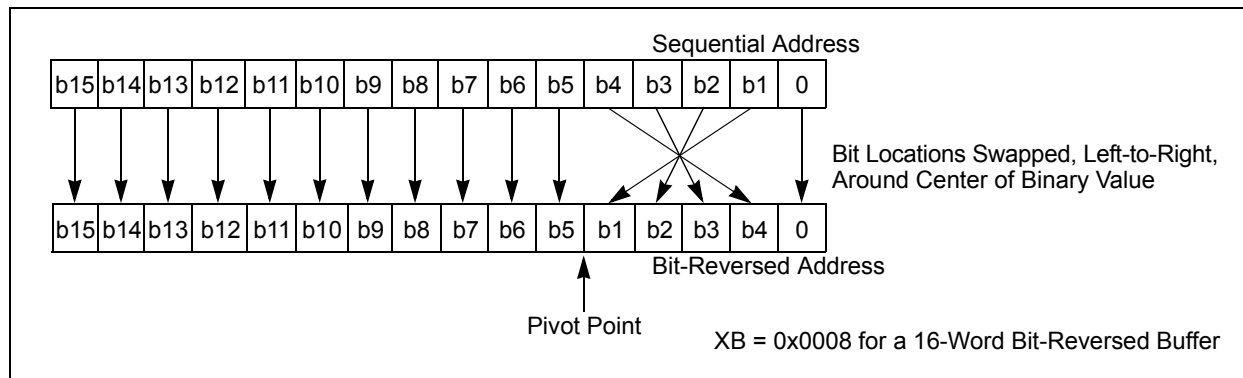

TABLE 4-67: BIT-REVERSED ADDRESSING SEQUENCE (16-ENTRY)

Normal Address					Bit-Reversed Address				
A3	A2	A1	A0	Decimal	A3	A2	A1	A0	Decimal
0	0	0	0	0	0	0	0	0	0
0	0	0	1	1	1	0	0	0	8
0	0	1	0	2	0	1	0	0	4
0	0	1	1	3	1	1	0	0	12
0	1	0	0	4	0	0	1	0	2
0	1	0	1	5	1	0	1	0	10
0	1	1	0	6	0	1	1	0	6
0	1	1	1	7	1	1	1	0	14
1	0	0	0	8	0	0	0	1	1
1	0	0	1	9	1	0	0	1	9
1	0	1	0	10	0	1	0	1	5
1	0	1	1	11	1	1	0	1	13
1	1	0	0	12	0	0	1	1	3
1	1	0	1	13	1	0	1	1	11
1	1	1	0	14	0	1	1	1	7
1	1	1	1	15	1	1	1	1	15

4.7 Interfacing Program and Data Memory Spaces

The dsPIC33EPXXXGM3XX/6XX/7XX architecture uses a 24-bit-wide Program Space and a 16-bit-wide Data Space. The architecture is also a modified Harvard scheme, meaning that data can also be present in the Program Space. To use this data successfully, it must be accessed in a way that preserves the alignment of information in both spaces.

Aside from normal execution, the architecture of the dsPIC33EPXXXGM3XX/6XX/7XX devices provides two methods by which Program Space can be accessed during operation:

- Using table instructions to access individual bytes or words anywhere in the Program Space
- Remapping a portion of the Program Space into the Data Space (Program Space Visibility)

Table instructions allow an application to read or write to small areas of the program memory. This capability makes the method ideal for accessing data tables that need to be updated periodically. It also allows access to all bytes of the program word. The remapping method allows an application to access a large block of data on a read-only basis, which is ideal for look-ups from a large table of static data. The application can only access the least significant word of the program word.

TABLE 4-68: PROGRAM SPACE ADDRESS CONSTRUCTION

Access Type	Access Space	Program Space Address				
		<23>	<22:16>	<15>	<14:1>	<0>
Instruction Access (Code Execution)	User	0	PC<22:1>			0
		0xx xxxx xxxxx xxxxx xxxxx xxx0				
TBLRD/TBLWT (Byte/Word Read/Write)	User	TBLPAG<7:0>		Data EA<15:0>		
		0xxx xxxxx		xxxx xxxxx xxxxx xxxxx		
	Configuration	TBLPAG<7:0>		Data EA<15:0>		
		1xxx xxxxx		xxxx xxxxx xxxxx xxxxx		

FIGURE 4-16: DATA ACCESS FROM PROGRAM SPACE ADDRESS GENERATION

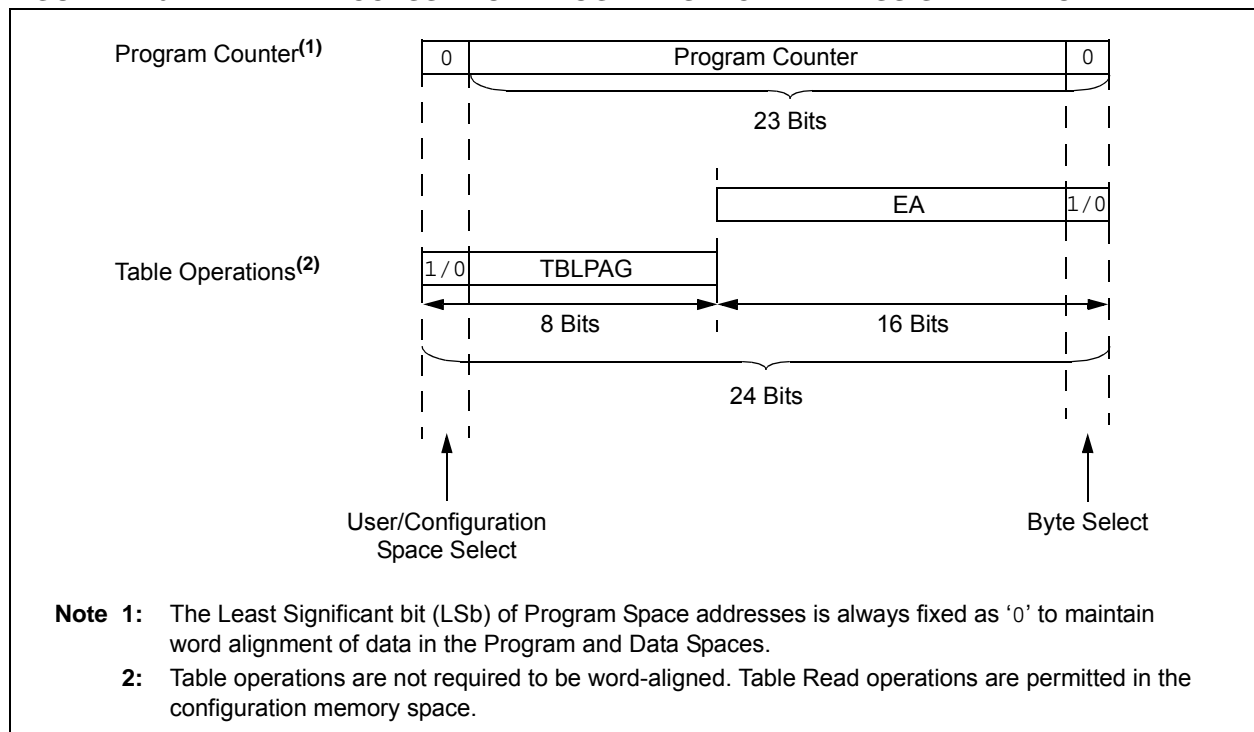

4.7.1 DATA ACCESS FROM PROGRAM MEMORY USING TABLE INSTRUCTIONS

The `TBLRDL` and `TBLWTL` instructions offer a direct method of reading or writing the lower word of any address within the Program Space without going through Data Space. The `TBLRDH` and `TBLWTH` instructions are the only method to read or write the upper 8 bits of a Program Space word as data.

The PC is incremented by two for each successive 24-bit program word. This allows program memory addresses to directly map to Data Space addresses. Program memory can thus be regarded as two 16-bit-wide word address spaces, residing side by side, each with the same address range. `TBLRDL` and `TBLWTL` access the space that contains the least significant data word. `TBLRDH` and `TBLWTH` access the space that contains the upper data byte.

Two table instructions are provided to move byte or word-sized (16-bit) data to and from Program Space. Both function as either byte or word operations.

- `TBLRDL` (Table Read Low):
 - In Word mode, this instruction maps the lower word of the Program Space location ($P<15:0>$) to a data address ($D<15:0>$)

- In Byte mode, either the upper or lower byte of the lower program word is mapped to the lower byte of a data address. The upper byte is selected when Byte Select is '1'; the lower byte is selected when it is '0'.

- `TBLRDH` (Table Read High):
 - In Word mode, this instruction maps the entire upper word of a program address ($P<23:16>$) to a data address. The 'phantom' byte ($D<15:8>$) is always '0'.
 - In Byte mode, this instruction maps the upper or lower byte of the program word to $D<7:0>$ of the data address in the `TBLRDL` instruction. The data is always '0' when the upper 'phantom' byte is selected (Byte Select = 1).

In a similar fashion, two table instructions, `TBLWTH` and `TBLWTL`, are used to write individual bytes or words to a Program Space address. The details of their operation are explained in [Section 5.0 "Flash Program Memory"](#).

For all table operations, the area of program memory space to be accessed is determined by the Table Page register (`TBLPAG`). `TBLPAG` covers the entire program memory space of the device, including user application and configuration spaces. When `TBLPAG<7> = 0`, the table page is located in the user memory space. When `TBLPAG<7> = 1`, the page is located in configuration space.

FIGURE 4-17: ACCESSING PROGRAM MEMORY WITH TABLE INSTRUCTIONS

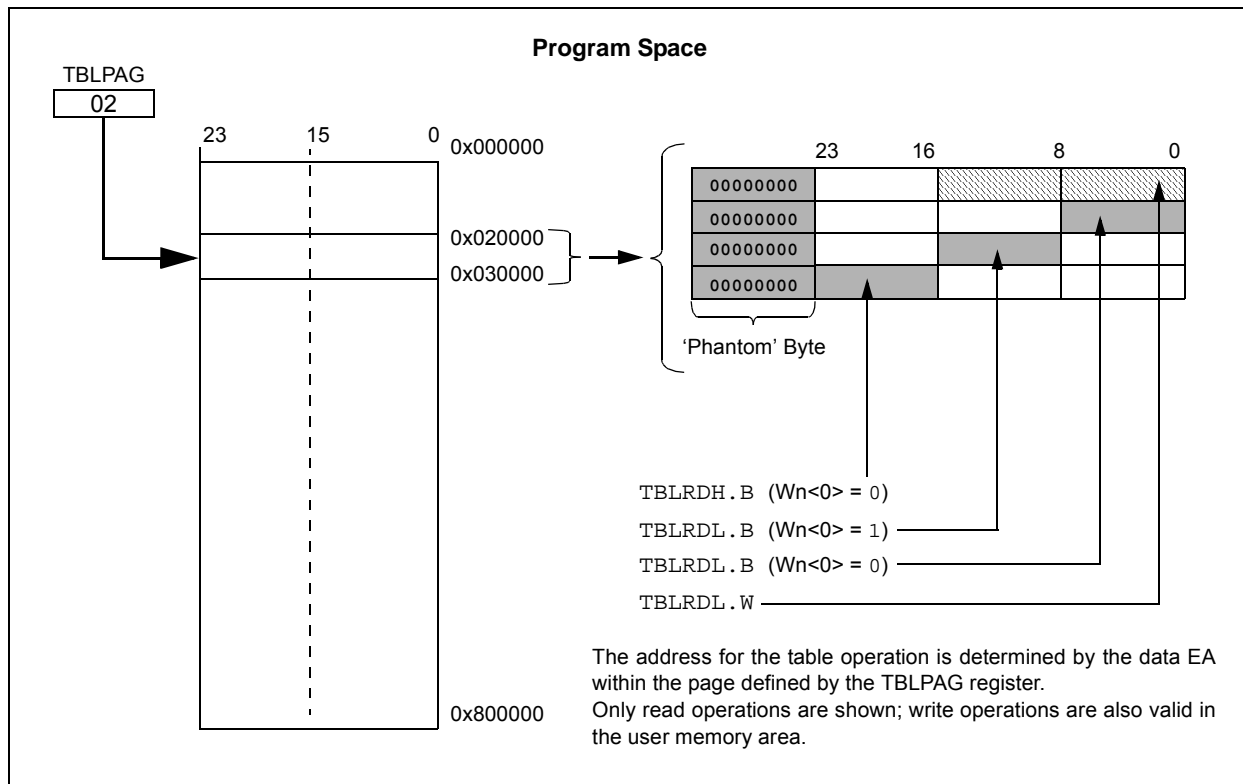

5.0 FLASH PROGRAM MEMORY

Note 1: This data sheet summarizes the features of the dsPIC33EPXXXGM3XX/6XX/7XX family of devices. It is not intended to be a comprehensive reference source. To complement the information in this data sheet, refer to the “dsPIC33/PIC24 Family Reference Manual”, “Flash Programming” (DS70609), which is available from the Microchip web site (www.microchip.com).

2: Some registers and associated bits described in this section may not be available on all devices. Refer to **Section 4.0 “Memory Organization”** in this data sheet for device-specific register and bit information.

The dsPIC33EPXXXGM3XX/6XX/7XX devices contain internal Flash program memory for storing and executing application code. The memory is readable, writable and erasable during normal operation, over the entire VDD range.

Flash memory can be programmed in two ways:

- In-Circuit Serial Programming™ (ICSP™)
- Run-Time Self-Programming (RTSP)

ICSP allows for a dsPIC33EPXXXGM3XX/6XX/7XX device to be serially programmed while in the end application circuit. This is done with two lines for programming clock and programming data (one of the alternate programming pin pairs: PGECx/PGEDx), and three other lines for power (VDD), ground (VSS) and

Master Clear ($\overline{\text{MCLR}}$). This allows customers to manufacture boards with unprogrammed devices and then program the device just before shipping the product. This also allows the most recent firmware or a custom firmware to be programmed.

RTSP is accomplished using TBLRD (Table Read) and TBLWT (Table Write) instructions. With RTSP, the user application can write program memory data as a double program memory word, a row of 64 instructions (192 bytes), and erase program memory in blocks of 512 instruction words (1536 bytes) at a time.

5.1 Table Instructions and Flash Programming

The Flash memory read and the double-word programming operations make use of the TBLRD and TBLWT instructions, respectively. These allow direct read and write access to the program memory space from the data memory while the device is in normal operating mode. The 24-bit target address in the program memory is formed using the TBLPAG<7:0> bits and the Effective Address (EA) from a W register, specified in the table instruction, as shown in **Figure 5-1**.

The TBLRDL and the TBLWTL instructions are used to read or write to bits<15:0> of program memory. TBLRDL and TBLWTL can access program memory in both Word and Byte modes.

The TBLRDH and TBLWTH instructions are used to read or write to bits<23:16> of program memory. TBLRDH and TBLWTH can also access program memory in Word or Byte mode.

FIGURE 5-1: ADDRESSING FOR TABLE REGISTERS

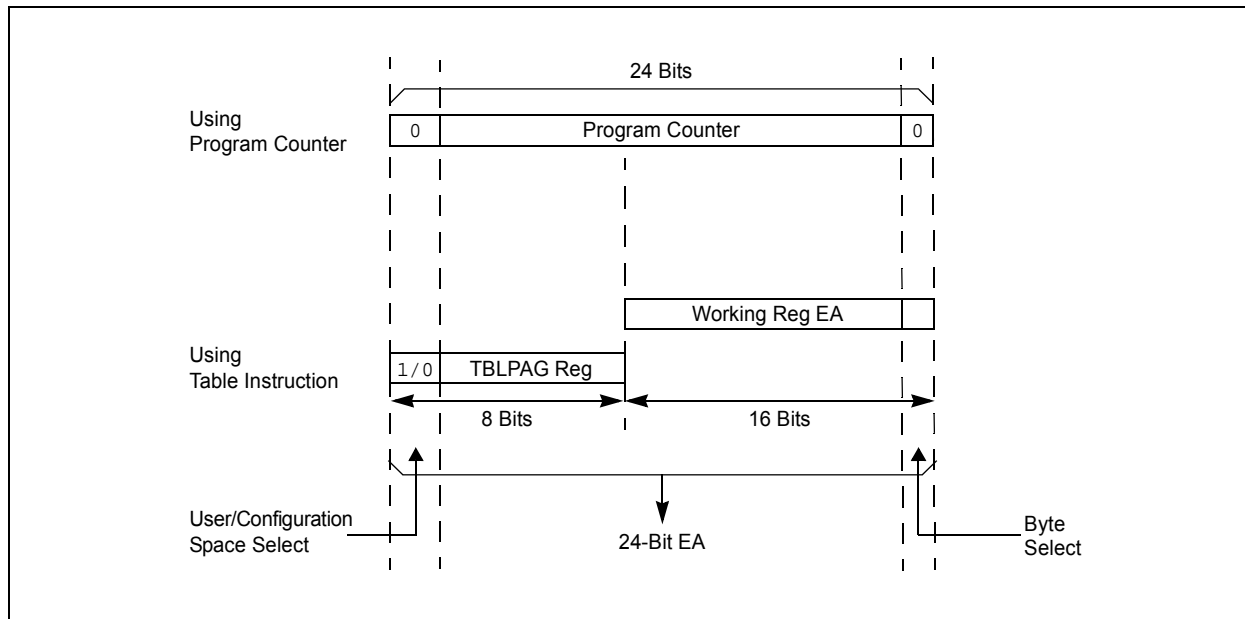

5.2 RTSP Operation

RTSP allows the user application to erase a single page of memory, program a row and to program two instruction words at a time. See [Table 1](#) in the “[dsPIC33EPXXGM3XX/6XX/7XX Product Family](#)” section for the page sizes of each device.

The Flash program memory array is organized into rows of 64 instructions or 192 bytes. RTSP allows the user application to erase a page of program memory, which consists of eight rows (512 instructions) at a time, and to program one row or two adjacent words at a time. The 8-row erase pages and single row write rows are edge-aligned, from the beginning of program memory, on boundaries of 1536 bytes and 192 bytes, respectively.

For more information on erasing and programming Flash memory, refer to the “[dsPIC33/PIC24 Family Reference Manual](#)”, “[Flash Programming](#)” (DS70609).

5.3 Programming Operations

A complete programming sequence is necessary for programming or erasing the internal Flash in RTSP mode. The processor stalls (waits) until the programming operation is finished.

For erase and program times, refer to Parameters [D137a](#) and [D137b](#) (Page Erase Time), and [D138a](#) and [D138b](#) (Word Write Cycle Time), in [Table 33-13](#).

Setting the WR bit (NVMCON<15>) starts the operation and the WR bit is automatically cleared when the operation is finished.

5.3.1 PROGRAMMING ALGORITHM FOR FLASH PROGRAM MEMORY

Programmers can program two adjacent words (24 bits x 2) of program Flash memory at a time on every other word address boundary (0x000002, 0x000006, 0x00000A, etc.). To do this, it is necessary to erase the page that contains the desired address of the location the user wants to change. Programmers can also program a row of data (64 instruction words/192 bytes) at a time using the row programming feature present in these devices. For row programming, the source data is fetched directly from the data memory (RAM) on these devices. Two new registers have been provided to point to the RAM location where the source data resides. The page that has the row to be programmed must first be erased before the programming operation.

For protection against accidental operations, the write initiate sequence for NVMKEY must be used to allow any erase or program operation to proceed. After the programming command has been executed, the user application must wait for the programming time until programming is complete. The two instructions following the start of the programming sequence should be NOPS.

Refer to the “[dsPIC33/PIC24 Family Reference Manual](#)”, “[Flash Programming](#)” (DS70609) for details and code examples on programming using RTSP.

5.4 Control Registers

Six SFRs are used to read and write the program Flash memory: NVMCON, NVMKEY, NVMADR, NVMADRU, NVMSRCADRL and NVMSRCADRH.

The NVMCON register ([Register 5-1](#)) controls which blocks are to be erased, which memory type is to be programmed and the start of the programming cycle.

NVMKEY ([Register 5-4](#)) is a write-only register that is used for write protection. To start a programming or erase sequence, the user application must consecutively write 0x55 and 0xAA to the NVMKEY register.

There are two NVM Address registers: NVMADRU and NVMADR. These two registers, when concatenated, form the 24-bit Effective Address (EA) of the selected word for programming operations, or the selected page for erase operations.

The NVMADRU register is used to hold the upper 8 bits of the EA, while the NVMADR register is used to hold the lower 16 bits of the EA.

The NVMSRCADRH and NVMSRCADRL registers are used to hold the source address of the data in the data memory that needs to be written to Flash memory.

dsPIC33EPXXXGM3XX/6XX/7XX

REGISTER 5-1: NVMCON: NONVOLATILE MEMORY (NVM) CONTROL REGISTER

R/SO-0 ⁽¹⁾	R/W-0 ⁽¹⁾	R/W-0 ⁽¹⁾	R/W-0	U-0	U-0	R/W-0	R/W-0
WR	WREN	WRERR	NVMSIDL ⁽²⁾	—	—	RPDF	URERR ⁽⁶⁾
bit 15							bit 8

U-0	U-0	U-0	U-0	R/W-0 ⁽¹⁾	R/W-0 ⁽¹⁾	R/W-0 ⁽¹⁾	R/W-0 ⁽¹⁾
—	—	—	—	NVMOP3 ^(3,4)	NVMOP2 ^(3,4)	NVMOP1 ^(3,4)	NVMOP0 ^(3,4)
bit 7							bit 0

Legend:	SO = Settable Only bit
R = Readable bit	W = Writable bit
-n = Value at POR	'1' = Bit is set
	U = Unimplemented bit, read as '0'
	'0' = Bit is cleared
	x = Bit is unknown

- bit 15 **WR:** NVM Write Control bit⁽¹⁾
 1 = Initiates a Flash memory program or erase operation; the operation is self-timed and the bit is cleared by hardware once the operation is complete
 0 = Program or erase operation is complete and inactive
- bit 14 **WREN:** NVM Write Enable bit⁽¹⁾
 1 = Enables Flash program/erase operations
 0 = Inhibits Flash program/erase operations
- bit 13 **WRERR:** NVM Write Sequence Error Flag bit⁽¹⁾
 1 = An improper program or erase sequence attempt, or termination has occurred (bit is set automatically on any set attempt of the WR bit)
 0 = The program or erase operation completed normally
- bit 12 **NVMSIDL:** NVM Stop in Idle Control bit⁽²⁾
 1 = Flash voltage regulator goes into Standby mode during Idle mode
 0 = Flash voltage regulator is active during Idle mode
- bit 11-10 **Unimplemented:** Read as '0'
- bit 9 **RPDF:** Bus Mastered Row Programming Data Format Control bit
 1 = Row data to be stored in RAM in compressed format
 0 = Row data to be stored in RAM in uncompressed format
- bit 8 **URERR:** Bus Mastered Row Programming Data Underrun Error Flag bit⁽⁶⁾
 1 = Indicates that a bus mastered row programming operation has been termination due to a data underrun error
 0 = Indicates no data underrun error is detected
- bit 7-4 **Unimplemented:** Read as '0'

- Note 1:** These bits can only be reset on POR.
- 2:** If this bit is set, there will be minimal power savings (IDLE), and upon exiting Idle mode, there is a delay (TVREG) before Flash memory becomes operational.
- 3:** All other combinations of NVMOP<3:0> are unimplemented.
- 4:** Execution of the PWRSAV instruction is ignored while any of the NVM operations are in progress.
- 5:** Two adjacent words on a 4-word boundary are programmed during execution of this operation.
- 6:** When URERR is set, the bus mastered row programming operation will terminate with the WRERR bit still set.

dsPIC33EPXXXGM3XX/6XX/7XX

REGISTER 5-1: NVMCON: NONVOLATILE MEMORY (NVM) CONTROL REGISTER (CONTINUED)

bit 3-0 **NVMOP<3:0>**: NVM Operation Select bits^(1,3,4)

- 1111 = Reserved
- 1110 = Reserved
- 1101 = Bulk erase primary program Flash memory
- 1100 = Reserved
- 1011 = Reserved
- 1010 = Reserved
- 0011 = Memory page erase operation
- 0010 = Memory row program operation with source data from RAM
- 0001 = Memory double-word program operation⁽⁵⁾
- 0000 = Reserved

Note 1: These bits can only be reset on POR.

2: If this bit is set, there will be minimal power savings (IDLE), and upon exiting Idle mode, there is a delay (TVREG) before Flash memory becomes operational.

3: All other combinations of NVMOP<3:0> are unimplemented.

4: Execution of the PWRSAV instruction is ignored while any of the NVM operations are in progress.

5: Two adjacent words on a 4-word boundary are programmed during execution of this operation.

6: When URERR is set, the bus mastered row programming operation will terminate with the WRERR bit still set.

REGISTER 5-2: NVMADRU: NONVOLATILE MEMORY UPPER ADDRESS REGISTER

U-0	U-0	U-0	U-0	U-0	U-0	U-0	U-0
—	—	—	—	—	—	—	—
bit 15							bit 8

R/W-x	R/W-x	R/W-x	R/W-x	R/W-x	R/W-x	R/W-x	R/W-x
NVMADRU<23:16>							
bit 7							bit 0

Legend:			
R = Readable bit	W = Writable bit	U = Unimplemented bit, read as '0'	
-n = Value at POR	'1' = Bit is set	'0' = Bit is cleared	x = Bit is unknown

bit 15-8 **Unimplemented:** Read as '0'

bit 7-0 **NVMADRU<23:16>:** Nonvolatile Memory Upper Write Address bits
 Selects the upper 8 bits of the location to program or erase in program Flash memory. This register may be read or written to by the user application.

REGISTER 5-3: NVMADR: NONVOLATILE MEMORY LOWER ADDRESS REGISTER

R/W-x	R/W-x	R/W-x	R/W-x	R/W-x	R/W-x	R/W-x	R/W-x
NVMADR<15:8>							
bit 15							bit 8

R/W-x	R/W-x	R/W-x	R/W-x	R/W-x	R/W-x	R/W-x	R/W-x
NVMADR<7:0>							
bit 7							bit 0

Legend:			
R = Readable bit	W = Writable bit	U = Unimplemented bit, read as '0'	
-n = Value at POR	'1' = Bit is set	'0' = Bit is cleared	x = Bit is unknown

bit 15-0 **NVMADR<15:0>:** Nonvolatile Memory Lower Write Address bits
 Selects the lower 16 bits of the location to program or erase in program Flash memory. This register may be read or written to by the user application.

dsPIC33EPXXXGM3XX/6XX/7XX

REGISTER 5-4: NVMKEY: NONVOLATILE MEMORY KEY REGISTER

U-0	U-0	U-0	U-0	U-0	U-0	U-0	U-0
—	—	—	—	—	—	—	—
bit 15							bit 8

W-0	W-0	W-0	W-0	W-0	W-0	W-0	W-0
NVMKEY<7:0>							
bit 7							bit 0

Legend:

R = Readable bit W = Writable bit U = Unimplemented bit, read as '0'
 -n = Value at POR '1' = Bit is set '0' = Bit is cleared x = Bit is unknown

bit 15-8 **Unimplemented:** Read as '0'
 bit 7-0 **NVMKEY<7:0>:** NVM Key Register (write-only) bits

REGISTER 5-5: NVMSRCADRH: NONVOLATILE DATA MEMORY UPPER ADDRESS REGISTER

U-0	U-0	U-0	U-0	U-0	U-0	U-0	U-0
—	—	—	—	—	—	—	—
bit 15							bit 8

R/W-x	R/W-x	R/W-x	R/W-x	R/W-x	R/W-x	R/W-x	R/W-x
NVMSRCADRH<23:16>							
bit 7							bit 0

Legend:

R = Readable bit W = Writable bit U = Unimplemented bit, read as '0'
 -n = Value at POR '1' = Bit is set '0' = Bit is cleared x = Bit is unknown

bit 15-8 **Unimplemented:** Read as '0'
 bit 7-0 **NVMSRCADRH<23:16>:** Nonvolatile Data Memory Upper Address bits

dsPIC33EPXXXGM3XX/6XX/7XX

REGISTER 5-6: NVMSRCADRL: NONVOLATILE DATA MEMORY LOWER ADDRESS REGISTER

R/W-x	R/W-x	R/W-x	R/W-x	R/W-x	R/W-x	R/W-x	R/W-x
NVMSRCADRL<15:8>							
bit 15							bit 8

R/W-x	R/W-x	R/W-x	R/W-x	R/W-x	R/W-x	R/W-x	r-0
NVMSRCADRL<7:1>							0
bit 7							bit 0

Legend:	r = Reserved bit	U = Unimplemented bit, read as '0'
R = Readable bit	W = Writable bit	'0' = Bit is cleared
-n = Value at POR	'1' = Bit is set	x = Bit is unknown

bit 15-1 **NVMSRCADRL<15:1>**: Nonvolatile Data Memory Lower Address bits

bit 0 **Reserved:** Maintain as '0'

dsPIC33EPXXGM3XX/6XX/7XX

NOTES:

6.0 RESETS

Note 1: This data sheet summarizes the features of the dsPIC33EPXXXGM3XX/6XX/7XX family of devices. It is not intended to be a comprehensive reference source. To complement the information in this data sheet, refer to the “dsPIC33/PIC24 Family Reference Manual”, “Reset” (DS70602), which is available from the Microchip web site (www.microchip.com).

2: Some registers and associated bits described in this section may not be available on all devices. Refer to **Section 4.0 “Memory Organization”** in this data sheet for device-specific register and bit information.

The Reset module combines all Reset sources and controls the device Master Reset Signal, $\overline{\text{SYSRST}}$. The following is a list of device Reset sources:

- POR: Power-on Reset
- BOR: Brown-out Reset
- MCLR: Master Clear Pin Reset
- SWR: RESET Instruction
- WDTO: Watchdog Timer Time-out Reset
- CM: Configuration Mismatch Reset
- TRAPR: Trap Conflict Reset
- IOPUWR: Illegal Condition Device Reset
 - Illegal Opcode Reset
 - Illegal Address Mode Reset
 - Uninitialized W Register Reset
 - Security Reset

A simplified block diagram of the Reset module is shown in **Figure 6-1**.

Any active source of Reset will make the $\overline{\text{SYSRST}}$ signal active. On system Reset, some of the registers associated with the CPU and peripherals are forced to a known Reset state and some are unaffected.

Note: Refer to the specific peripheral section or **Section 4.0 “Memory Organization”** of this manual for register Reset states.

All types of device Reset set a corresponding status bit in the RCON register to indicate the type of Reset (see **Register 6-1**).

A POR clears all the bits, except for the POR and BOR bits (RCON<1:0>) that are set. The user application can set or clear any bit at any time during code execution. The RCON bits only serve as status bits. Setting a particular Reset status bit in software does not cause a device Reset to occur.

The RCON register also has other bits associated with the Watchdog Timer and device power-saving states. The function of these bits is discussed in other sections of this manual.

Note: The status bits in the RCON register should be cleared after they are read so that the next RCON register value after a device Reset is meaningful.

Note: In all types of Resets, to select the device clock source, the contents of OSCCON are initialized from the FNOSCx Configuration bits in the FOSCSEL Configuration register.

FIGURE 6-1: RESET SYSTEM BLOCK DIAGRAM

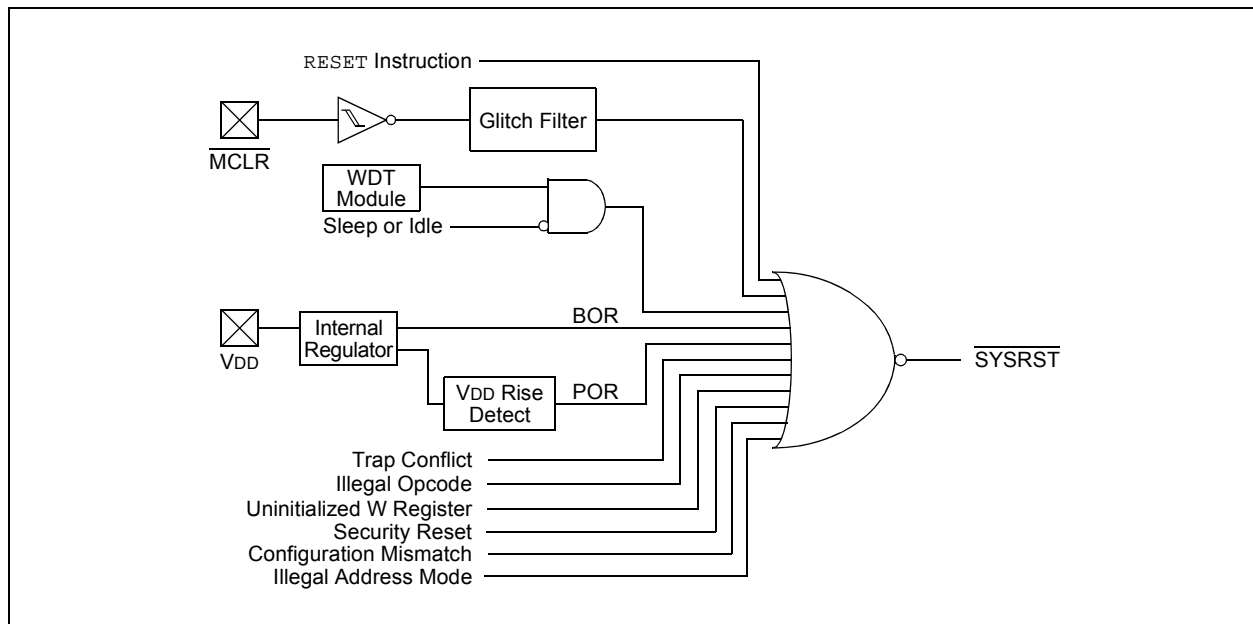

dsPIC33EPXXXGM3XX/6XX/7XX

REGISTER 6-1: RCON: RESET CONTROL REGISTER⁽¹⁾

R/W-0	R/W-0	U-0	U-0	R/W-0	U-0	R/W-0	R/W-0
TRAPR	IOPUWR	—	—	VREGSF	—	CM	VREGS
bit 15							bit 8

R/W-0	R/W-0	R/W-0	R/W-0	R/W-0	R/W-0	R/W-1	R/W-1
EXTR	SWR	SWDTEN ⁽²⁾	WDTO	SLEEP	IDLE	BOR	POR
bit 7							bit 0

Legend:

R = Readable bit W = Writable bit U = Unimplemented bit, read as '0'
 -n = Value at POR '1' = Bit is set '0' = Bit is cleared x = Bit is unknown

- bit 15 **TRAPR:** Trap Reset Flag bit
 1 = A Trap Conflict Reset has occurred
 0 = A Trap Conflict Reset has not occurred
- bit 14 **IOPUWR:** Illegal Opcode or Uninitialized W Access Reset Flag bit
 1 = An illegal opcode detection, an illegal address mode or Uninitialized W register used as an Address Pointer caused a Reset
 0 = An illegal opcode or Uninitialized W Register Reset has not occurred
- bit 13-12 **Unimplemented:** Read as '0'
- bit 11 **VREGSF:** Flash Voltage Regulator Standby During Sleep bit
 1 = Flash Voltage regulator is active during Sleep
 0 = Flash Voltage regulator goes into Standby mode during Sleep
- bit 10 **Unimplemented:** Read as '0'
- bit 9 **CM:** Configuration Mismatch Flag bit
 1 = A Configuration Mismatch Reset has occurred.
 0 = A Configuration Mismatch Reset has NOT occurred
- bit 8 **VREGS:** Voltage Regulator Standby During Sleep bit
 1 = Voltage regulator is active during Sleep
 0 = Voltage regulator goes into Standby mode during Sleep
- bit 7 **EXTR:** External Reset (\overline{MCLR}) Pin bit
 1 = A Master Clear (pin) Reset has occurred
 0 = A Master Clear (pin) Reset has not occurred
- bit 6 **SWR:** Software RESET (Instruction) Flag bit
 1 = A RESET instruction has been executed
 0 = A RESET instruction has not been executed
- bit 5 **SWDTEN:** Software Enable/Disable of WDT bit⁽²⁾
 1 = WDT is enabled
 0 = WDT is disabled
- bit 4 **WDTO:** Watchdog Timer Time-out Flag bit
 1 = WDT time-out has occurred
 0 = WDT time-out has not occurred

Note 1: All of the Reset status bits can be set or cleared in software. Setting one of these bits in software does not cause a device Reset.

2: If the FWDTEN Configuration bit is '1' (unprogrammed), the WDT is always enabled, regardless of the SWDTEN bit setting.

REGISTER 6-1: RCON: RESET CONTROL REGISTER⁽¹⁾ (CONTINUED)

bit 3	SLEEP: Wake-up from Sleep Flag bit 1 = Device was in Sleep mode 0 = Device was not in Sleep mode
bit 2	IDLE: Wake-up from Idle Flag bit 1 = Device was in Idle mode 0 = Device was not in Idle mode
bit 1	BOR: Brown-out Reset Flag bit 1 = A Brown-out Reset has occurred 0 = A Brown-out Reset has not occurred
bit 0	POR: Power-on Reset Flag bit 1 = A Power-on Reset has occurred 0 = A Power-on Reset has not occurred

- Note 1:** All of the Reset status bits can be set or cleared in software. Setting one of these bits in software does not cause a device Reset.
- 2:** If the FWDTEN Configuration bit is '1' (unprogrammed), the WDT is always enabled, regardless of the SWDTEN bit setting.

dsPIC33EPXXGM3XX/6XX/7XX

NOTES:

7.0 INTERRUPT CONTROLLER

Note 1: This data sheet summarizes the features of the dsPIC33EPXXXGM3XX/6XX/7XX family of devices. It is not intended to be a comprehensive reference source. To complement the information in this data sheet, refer to the “*dsPIC33/PIC24 Family Reference Manual*”, “**Interrupts**” (DS70000600), which is available from the Microchip web site (www.microchip.com).

2: Some registers and associated bits described in this section may not be available on all devices. Refer to [Section 4.0 “Memory Organization”](#) in this data sheet for device-specific register and bit information.

The dsPIC33EPXXXGM3XX/6XX/7XX interrupt controller reduces the numerous peripheral interrupt request signals to a single interrupt request signal to the dsPIC33EPXXXGM3XX/6XX/7XX CPU.

The interrupt controller has the following features:

- Up to eight processor exceptions and software traps
- Eight user-selectable priority levels
- Interrupt Vector Table (IVT) with a unique vector for each interrupt or exception source
- Fixed priority within a specified user priority level
- Fixed interrupt entry and return latencies

7.1 Interrupt Vector Table

The dsPIC33EPXXXGM3XX/6XX/7XX Interrupt Vector Table (IVT), shown in [Figure 7-1](#), resides in program memory, starting at location, 000004h. The IVT contains seven non-maskable trap vectors and up to 151 sources of interrupt. In general, each interrupt source has its own vector. Each interrupt vector contains a 24-bit-wide address. The value programmed into each interrupt vector location is the starting address of the associated Interrupt Service Routine (ISR).

Interrupt vectors are prioritized in terms of their natural priority. This priority is linked to their position in the vector table. Lower addresses generally have a higher natural priority. For example, the interrupt associated with Vector 0 takes priority over interrupts at any other vector address.

7.2 Reset Sequence

A device Reset is not a true exception because the interrupt controller is not involved in the Reset process. The dsPIC33EPXXXGM3XX/6XX/7XX devices clear their registers in response to a Reset, which forces the PC to zero. The device then begins program execution at location, 0x000000. A `GOTO` instruction at the Reset address can redirect program execution to the appropriate start-up routine.

Note: Any unimplemented or unused vector locations in the IVT should be programmed with the address of a default interrupt handler routine that contains a `RESET` instruction.

dsPIC33EPXXXGM3XX/6XX/7XX

FIGURE 7-1: dsPIC33EPXXXGM3XX/6XX/7XX INTERRUPT VECTOR TABLE

Reset – GOTO Instruction	0x000000
Reset – GOTO Address	0x000002
Oscillator Fail Trap Vector	0x000004
Address Error Trap Vector	0x000006
Generic Hard Trap Vector	0x000008
Stack Error Trap Vector	0x00000A
Math Error Trap Vector	0x00000C
DMA Controller Error Trap Vector	0x00000E
Generic Soft Trap Vector	0x000010
Reserved	0x000012
Interrupt Vector 0	0x000014
Interrupt Vector 1	0x000016
:	:
:	:
:	:
Interrupt Vector 52	0x00007C
Interrupt Vector 53	0x00007E
Interrupt Vector 54	0x000080
:	:
:	:
:	:
Interrupt Vector 116	0x0000FC
Interrupt Vector 117	0x0000FE
Interrupt Vector 118	0x000100
Interrupt Vector 119	0x000102
Interrupt Vector 120	0x000104
:	:
:	:
:	:
Interrupt Vector 244	0x0001FC
Interrupt Vector 245	0x0001FE
START OF CODE	0x000200

See Table 7-1 for Interrupt Vector Details

TABLE 7-1: INTERRUPT VECTOR DETAILS

Interrupt Source	Vector #	IRQ #	IVT Address	Interrupt Bit Location		
				Flag	Enable	Priority
Highest Natural Order Priority						
INT0 – External Interrupt 0	8	0	0x000014	IFS0<0>	IEC0<0>	IPC0<2:0>
IC1 – Input Capture 1	9	1	0x000016	IFS0<1>	IEC0<1>	IPC0<6:4>
OC1 – Output Compare 1	10	2	0x000018	IFS0<2>	IEC0<2>	IPC0<10:8>
T1 – Timer1	11	3	0x00001A	IFS0<3>	IEC0<3>	IPC0<14:12>
DMA0 – DMA Channel 0	12	4	0x00001C	IFS0<4>	IEC0<4>	IPC1<2:0>
IC2 – Input Capture 2	13	5	0x00001E	IFS0<5>	IEC0<5>	IPC1<6:4>
OC2 – Output Compare 2	14	6	0x000020	IFS0<6>	IEC0<6>	IPC1<10:8>
T2 – Timer2	15	7	0x000022	IFS0<7>	IEC0<7>	IPC1<14:12>
T3 – Timer3	16	8	0x000024	IFS0<8>	IEC0<8>	IPC2<2:0>
SPI1E – SPI1 Error	17	9	0x000026	IFS0<9>	IEC0<9>	IPC2<6:4>
SPI1 – SPI1 Transfer Done	18	10	0x000028	IFS0<10>	IEC0<10>	IPC2<10:8>
U1RX – UART1 Receiver	19	11	0x00002A	IFS0<11>	IEC0<11>	IPC2<14:12>
U1TX – UART1 Transmitter	20	12	0x00002C	IFS0<12>	IEC0<12>	IPC3<2:0>
AD1 – ADC1 Convert Done	21	13	0x00002E	IFS0<13>	IEC0<13>	IPC3<6:4>
DMA1 – DMA Channel 1	22	14	0x000030	IFS0<14>	IEC0<14>	IPC3<10:8>
Reserved	23	15	0x000032	—	—	—
SI2C1 – I2C1 Slave Event	24	16	0x000034	IFS1<0>	IEC1<0>	IPC4<2:0>
MI2C1 – I2C1 Master Event	25	17	0x000036	IFS1<1>	IEC1<1>	IPC4<6:4>
CMP1 – Comparator Combined Event	26	18	0x000038	IFS1<2>	IEC1<2>	IPC4<10:8>
CN – Input Change Interrupt	27	19	0x00003A	IFS1<3>	IEC1<3>	IPC4<14:12>
INT1 – External Interrupt 1	28	20	0x00003C	IFS1<4>	IEC1<4>	IPC5<2:0>
AD2 – ADC2 Convert Done	29	21	0x00003E	IFS1<5>	IEC1<5>	IPC5<6:4>
IC7 – Input Capture 7	30	22	0x000040	IFS1<6>	IEC1<6>	IPC5<10:8>
IC8 – Input Capture 8	31	23	0x000042	IFS1<7>	IEC1<7>	IPC5<14:12>
DMA2 – DMA Channel 2	32	24	0x000044	IFS1<8>	IEC1<8>	IPC6<2:0>
OC3 – Output Compare 3	33	25	0x000046	IFS1<9>	IEC1<9>	IPC6<6:4>
OC4 – Output Compare 4	34	26	0x000048	IFS1<10>	IEC1<10>	IPC6<10:8>
T4 – Timer4	35	27	0x00004A	IFS1<11>	IEC1<11>	IPC6<14:12>
T5 – Timer5	36	28	0x00004C	IFS1<12>	IEC1<12>	IPC7<2:0>
INT2 – External Interrupt 2	37	29	0x00004E	IFS1<13>	IEC1<13>	IPC7<6:4>
U2RX – UART2 Receiver	38	30	0x000050	IFS1<14>	IEC1<14>	IPC7<10:8>
U2TX – UART2 Transmitter	39	31	0x000052	IFS1<15>	IEC1<15>	IPC7<14:12>
SPI2E – SPI2 Error	40	32	0x000054	IFS2<0>	IEC2<0>	IPC8<2:0>
SPI2 – SPI2 Transfer Done	41	33	0x000056	IFS2<1>	IEC2<1>	IPC8<6:4>
C1RX – CAN1 RX Data Ready ⁽¹⁾	42	34	0x000058	IFS2<2>	IEC2<2>	IPC8<10:8>
C1 – CAN1 Event ⁽¹⁾	43	35	0x00005A	IFS2<3>	IEC2<3>	IPC8<14:12>
DMA3 – DMA Channel 3	44	36	0x00005C	IFS2<4>	IEC2<4>	IPC9<2:0>
IC3 – Input Capture 3	45	37	0x00005E	IFS2<5>	IEC2<5>	IPC9<6:4>
IC4 – Input Capture 4	46	38	0x000060	IFS2<6>	IEC2<6>	IPC9<10:8>
IC5 – Input Capture 5	47	39	0x000062	IFS2<7>	IEC2<7>	IPC9<14:12>
IC6 – Input Capture 6	48	40	0x000064	IFS2<8>	IEC2<8>	IPC10<2:0>

Note 1: This interrupt source is available on dsPIC33EPXXXGM6XX/7XX devices only.

2: This interrupt source is not available on 44-pin devices.

dsPIC33EPXXXGM3XX/6XX/7XX

TABLE 7-1: INTERRUPT VECTOR DETAILS (CONTINUED)

Interrupt Source	Vector #	IRQ #	IVT Address	Interrupt Bit Location		
				Flag	Enable	Priority
OC5 – Output Compare 5	49	41	0x000066	IFS2<9>	IEC2<9>	IPC10<6:4>
OC6 – Output Compare 6	50	42	0x000068	IFS2<10>	IEC2<10>	IPC10<10:8>
OC7 – Output Compare 7	51	43	0x00006A	IFS2<11>	IEC2<11>	IPC10<14:12>
OC8 – Output Compare 8	52	44	0x00006C	IFS2<12>	IEC2<12>	IPC11<2:0>
PMP – Parallel Master Port ⁽²⁾	53	45	0x00006E	IFS2<13>	IEC2<13>	IPC11<6:4>
Reserved	54	46	0x000070	—	—	—
T6 – Timer6	55	47	0x000072	IFS2<15>	IEC2<15>	IPC11<14:12>
T7 – Timer7	56	48	0x000074	IFS3<0>	IEC3<0>	IPC12<2:0>
SI2C2 – I2C2 Slave Event	57	49	0x000076	IFS3<1>	IEC3<1>	IPC12<6:4>
MI2C2 – I2C2 Master Event	58	50	0x000078	IFS3<2>	IEC3<2>	IPC12<10:8>
T8 – Timer8	59	51	0x00007A	IFS3<3>	IEC3<3>	IPC12<14:12>
T9 – Timer9	60	52	0x00007C	IFS3<4>	IEC3<4>	IPC13<2:0>
INT3 – External Interrupt 3	61	53	0x00007E	IFS3<5>	IEC3<5>	IPC13<6:4>
INT4 – External Interrupt 4	62	54	0x000080	IFS3<6>	IEC3<6>	IPC13<10:8>
C2RX – CAN2 RX Data Ready ⁽¹⁾	63	55	0x000082	IFS3<7>	IEC3<7>	IPC13<14:12>
C2 – CAN2 Event ⁽¹⁾	64	56	0x000084	IFS3<8>	IEC3<8>	IPC14<2:0>
PSEM – PCPWM Primary Event	65	57	0x000086	IFS3<9>	IEC3<9>	IPC14<6:4>
QE11 – QE11 Position Counter Compare	66	58	0x000088	IFS3<10>	IEC3<10>	IPC14<10:8>
DCIE – DCI Fault Interrupt	67	59	0x00008A	IFS3<11>	IEC3<11>	IPC14<14:12>
DCI – DCI Transfer Done	68	60	0x00008C	IFS3<12>	IEC3<12>	IPC15<2:0>
Reserved	69	61	0x00008E	—	—	—
RTCC – Real-Time Clock and Calendar ⁽²⁾	70	62	0x000090	IFS3<14>	IEC3<14>	IPC15<10:8>
Reserved	71-72	63-64	0x000092-0x000094	—	—	—
U1E – UART1 Error Interrupt	73	65	0x000096	IFS4<1>	IEC4<1>	IPC16<6:4>
U2E – UART2 Error Interrupt	74	66	0x000098	IFS4<2>	IEC4<2>	IPC16<10:8>
CRC – CRC Generator Interrupt	75	67	0x00009A	IFS4<3>	IEC4<3>	IPC16<14:12>
Reserved	76-77	68-69	0x00009C-0x00009E	—	—	—
C1TX – CAN1 TX Data Request ⁽¹⁾	78	70	0x0000A0	IFS4<6>	IEC4<6>	IPC17<10:8>
C2TX – CAN2 TX Data Request ⁽¹⁾	79	71	0x0000A2	IFS4<7>	IEC4<7>	IPC17<14:12>
Reserved	80	72	0x0000A4	—	—	—
PSSEM – PCPWM Secondary Event	81	73	0x0000A6	IFS4<9>	IEC4<9>	IPC18<6:4>
Reserved	82	74	0x0000A8	—	—	—
QE12 – QE12 Position Counter Compare	83	75	0x0000AA	IFS4<11>	IEC4<11>	IPC18<14:12>
Reserved	84	76	0x0000AC	—	—	—
CTMU – CTMU Interrupt	85	77	0x0000AE	IFS4<13>	IEC4<13>	IPC19<6:4>
Reserved	86-88	78-80	0x0000B0-0x0000B4	—	—	—
U3E – UART3 Error Interrupt	89	81	0x0000B6	IFS5<1>	IEC5<1>	IPC20<6:4>
U3RX – UART3 Receiver	90	82	0x0000B8	IFS5<2>	IEC5<2>	IPC20<10:8>
U3TX – UART3 Transmitter	91	83	0x0000BA	IFS5<3>	IEC5<3>	IPC20<14:12>
Reserved	92-94	84-86	0x0000BC-0x0000C0	—	—	—
U4E – UART4 Error Interrupt	95	87	0x0000C2	IFS5<7>	IEC5<7>	IPC21<14:12>
U4RX – UART4 Receiver	96	88	0x0000C4	IFS5<8>	IEC5<8>	IPC22<2:0>
U4TX – UART4 Transmitter	97	89	0x0000C6	IFS5<9>	IEC5<9>	IPC22<6:4>

Note 1: This interrupt source is available on dsPIC33EPXXXGM6XX/7XX devices only.

2: This interrupt source is not available on 44-pin devices.

dsPIC33EPXXXGM3XX/6XX/7XX

TABLE 7-1: INTERRUPT VECTOR DETAILS (CONTINUED)

Interrupt Source	Vector #	IRQ #	IVT Address	Interrupt Bit Location		
				Flag	Enable	Priority
SPI3E – SPI3 Error	98	90	0x0000C8	IFS5<10>	IEC5<10>	IPC22<10:8>
SPI3 – SPI3 Transfer Done	99	91	0x0000CA	IFS5<11>	IEC5<11>	IPC22<14:12>
Reserved	100-101	92-93	0x0000CC-0x0000CE	—	—	—
PWM1 – PWM Generator 1	102	94	0x0000D0	IFS5<14>	IEC5<14>	IPC23<10:8>
PWM2 – PWM Generator 2	103	95	0x0000D2	IFS5<15>	IEC5<15>	IPC23<14:12>
PWM3 – PWM Generator 3	104	96	0x0000D4	IFS6<0>	IEC6<0>	IPC24<2:0>
PWM4 – PWM Generator 4	105	97	0x0000D6	IFS6<1>	IEC6<1>	IPC24<6:4>
PWM5 – PWM Generator 5	106	98	0x0000D8	IFS6<2>	IEC6<2>	IPC24<10:8>
PWM6 – PWM Generator 6	107	99	0x0000DA	IFS6<3>	IEC6<3>	IPC24<14:12>
Reserved	108-149	100-141	0x0000DC-0x00012E	—	—	—
ICD – ICD Application	150	142	0x000142	IFS8<14>	IEC8<14>	IPC35<10:8>
JTAG – JTAG Programming	151	143	0x000130	IFS8<15>	IEC8<15>	IPC35<14:12>
Reserved	152	144	0x000134	—	—	—
PTGSTEP – PTG Step	153	145	0x000136	IFS9<1>	IEC9<1>	IPC36<6:4>
PTGWDT – PTG Watchdog Time-out	154	146	0x000138	IFS9<2>	IEC9<2>	IPC36<10:8>
PTG0 – PTG Interrupt 0	155	147	0x00013A	IFS9<3>	IEC9<3>	IPC36<14:12>
PTG1 – PTG Interrupt 1	156	148	0x00013C	IFS9<4>	IEC9<4>	IPC37<2:0>
PTG2 – PTG Interrupt 2	157	149	0x00013E	IFS9<5>	IEC9<5>	IPC37<6:4>
PTG3 – PTG Interrupt 3	158	150	0x000140	IFS9<6>	IEC9<6>	IPC37<10:8>
Reserved	159-245	151-245	0x000142-0x0001FE	—	—	—
Lowest Natural Order Priority						

Note 1: This interrupt source is available on dsPIC33EPXXXGM6XX/7XX devices only.

Note 2: This interrupt source is not available on 44-pin devices.

7.3 Interrupt Control and Status Registers

dsPIC33EPXXXGM3XX/6XX/7XX devices implement the following registers for the interrupt controller:

- INTCON1
- INTCON2
- INTCON3
- INTCON4
- IFSx
- IECx
- IPCx
- INTTREG

7.3.1 INTCON1 THROUGH INTCON4

Global interrupt control functions are controlled from INTCON1, INTCON2, INTCON3 and INTCON4.

INTCON1 contains the Interrupt Nesting Disable bit (NSTDIS) as well as the control and status flags for the processor trap sources.

The INTCON2 register controls external interrupt request signal behavior and also contains the Global Interrupt Enable bit (GIE).

INTCON3 contains the status flags for the DMA and DO stack overflow status trap sources.

The INTCON4 register contains the Software Generated Hard Trap (SGHT) status bit.

7.3.2 IFSx

The IFSx registers maintain all of the interrupt request flags. Each source of interrupt has a status bit, which is set by the respective peripherals or external signal and is cleared via software.

7.3.3 IECx

The IECx registers maintain all of the interrupt enable bits. These control bits are used to individually enable interrupts from the peripherals or external signals.

7.3.4 IPCx

The IPCx registers are used to set the Interrupt Priority Level (IPL) for each source of interrupt. Each user interrupt source can be assigned to one of eight priority levels.

7.3.5 INTTREG

The INTTREG register contains the associated interrupt vector number and the new CPU Interrupt Priority Level, which are latched into Vector Number (VECNUM<7:0>) and Interrupt Level (ILR<3:0>) bit fields in the INTTREG register. The new Interrupt Priority Level is the priority of the pending interrupt.

The interrupt sources are assigned to the IFSx, IECx and IPCx registers in the same sequence as they are listed in [Table 7-1](#). For example, the INT0 (External Interrupt 0) is shown as having Vector Number 8 and a natural order priority of 0. Thus, the INTOIF bit is found in IFS0<0>, the INTOIE bit in IEC0<0> and the INTOIP bits in the first position of IPC0 (IPC0<2:0>).

7.3.6 STATUS/CONTROL REGISTERS

Although these registers are not specifically part of the interrupt control hardware, two of the CPU Control registers contain bits that control interrupt functionality. For more information on these registers, refer to the “*dsPIC33/PIC24 Family Reference Manual*”, “**CPU**” (DS70359).

- The CPU STATUS Register, SR, contains the IPL<2:0> bits (SR<7:5>). These bits indicate the current CPU Interrupt Priority Level. The user software can change the current CPU Interrupt Priority Level by writing to the IPLx bits.
- The CORCON register contains the IPL3 bit, which together with IPL<2:0>, also indicates the current CPU Interrupt Priority Level. IPL3 is a read-only bit so that trap events cannot be masked by the user software.

All Interrupt registers are described in [Register 7-3](#) through [Register 7-7](#) in the following pages.

REGISTER 7-1: SR: CPU STATUS REGISTER⁽¹⁾

R/W-0	R/W-0	R/W-0	R/W-0	R/C-0	R/C-0	R-0	R/W-0
OA	OB	SA	SB	OAB	SAB	DA	DC
bit 15							bit 8

R/W-0 ⁽³⁾	R/W-0 ⁽³⁾	R/W-0 ⁽³⁾	R-0	R/W-0	R/W-0	R/W-0	R/W-0
IPL2 ⁽²⁾	IPL1 ⁽²⁾	IPL0 ⁽²⁾	RA	N	OV	Z	C
bit 7							bit 0

Legend:	C = Clearable bit	U = Unimplemented bit, read as '0'
R = Readable bit	W = Writable bit	'0' = Bit is cleared
-n = Value at POR	'1' = Bit is set	x = Bit is unknown

- bit 7-5 **IPL<2:0>**: CPU Interrupt Priority Level Status bits^(2,3)
- 111 = CPU Interrupt Priority Level is 7 (15); user interrupts are disabled
 - 110 = CPU Interrupt Priority Level is 6 (14)
 - 101 = CPU Interrupt Priority Level is 5 (13)
 - 100 = CPU Interrupt Priority Level is 4 (12)
 - 011 = CPU Interrupt Priority Level is 3 (11)
 - 010 = CPU Interrupt Priority Level is 2 (10)
 - 001 = CPU Interrupt Priority Level is 1 (9)
 - 000 = CPU Interrupt Priority Level is 0 (8)

- Note 1:** For complete register details, see [Register 3-1](#).
- 2:** The IPL<2:0> bits are concatenated with the IPL<3> bit (CORCON<3>) to form the CPU Interrupt Priority Level. The value in parentheses indicates the IPL if IPL<3> = 1. User interrupts are disabled when IPL<3> = 1.
- 3:** The IPL<2:0> Status bits are read-only when the NSTDIS bit (INTCON1<15>) = 1.

dsPIC33EPXXXGM3XX/6XX/7XX

REGISTER 7-2: CORCON: CORE CONTROL REGISTER⁽¹⁾

R/W-0	U-0	R/W-0	R/W-0	R/W-0	R-0	R-0	R-0
VAR	—	US1	US0	EDT	DL2	DL1	DL0
bit 15							bit 8

R/W-0	R/W-0	R/W-1	R/W-0	R/C-0	R-0	R/W-0	R/W-0
SATA	SATB	SATDW	ACCSAT	IPL3⁽²⁾	SFA	RND	IF
bit 7							bit 0

Legend:

R = Readable bit W = Writable bit U = Unimplemented bit, read as '0'
 -n = Value at POR '1' = Bit is set '0' = Bit is cleared x = Bit is unknown

bit 15 **VAR:** Variable Exception Processing Latency Control bit
 1 = Variable exception processing latency is enabled
 0 = Fixed exception processing latency is enabled

bit 3 **IPL3:** CPU Interrupt Priority Level Status bit 3⁽²⁾
 1 = CPU Interrupt Priority Level is greater than 7
 0 = CPU Interrupt Priority Level is 7 or less

Note 1: For complete register details, see [Register 3-2](#).

2: The IPL3 bit is concatenated with the IPL<2:0> bits (SR<7:5>) to form the CPU Interrupt Priority Level.

dsPIC33EPXXXGM3XX/6XX/7XX

REGISTER 7-3: INTCON1: INTERRUPT CONTROL REGISTER 1

R/W-0	R/W-0	R/W-0	R/W-0	R/W-0	R/W-0	R/W-0	R/W-0
NSTDIS	OVAERR	OVBERR	COVAERR	COVBERR	OVATE	OVBTE	COVTE
bit 15							bit 8

R/W-0	R/W-0	R/W-0	R/W-0	R/W-0	R/W-0	R/W-0	U-0
SFTACERR	DIV0ERR	DMACERR	MATHERR	ADDRERR	STKERR	OSCFAIL	—
bit 7							bit 0

Legend:

R = Readable bit	W = Writable bit	U = Unimplemented bit, read as '0'
-n = Value at POR	'1' = Bit is set	'0' = Bit is cleared
		x = Bit is unknown

- bit 15 **NSTDIS:** Interrupt Nesting Disable bit
1 = Interrupt nesting is disabled
0 = Interrupt nesting is enabled
- bit 14 **OVAERR:** Accumulator A Overflow Trap Flag bit
1 = Trap was caused by overflow of Accumulator A
0 = Trap was not caused by overflow of Accumulator A
- bit 13 **OVBERR:** Accumulator B Overflow Trap Flag bit
1 = Trap was caused by overflow of Accumulator B
0 = Trap was not caused by overflow of Accumulator B
- bit 12 **COVAERR:** Accumulator A Catastrophic Overflow Trap Flag bit
1 = Trap was caused by catastrophic overflow of Accumulator A
0 = Trap was not caused by catastrophic overflow of Accumulator A
- bit 11 **COVBERR:** Accumulator B Catastrophic Overflow Trap Flag bit
1 = Trap was caused by catastrophic overflow of Accumulator B
0 = Trap was not caused by catastrophic overflow of Accumulator B
- bit 10 **OVATE:** Accumulator A Overflow Trap Enable bit
1 = Trap overflow of Accumulator A
0 = Trap is disabled
- bit 9 **OVBTE:** Accumulator B Overflow Trap Enable bit
1 = Trap overflow of Accumulator B
0 = Trap is disabled
- bit 8 **COVTE:** Catastrophic Overflow Trap Enable bit
1 = Trap on catastrophic overflow of Accumulator A or B is enabled
0 = Trap is disabled
- bit 7 **SFTACERR:** Shift Accumulator Error Status bit
1 = Math error trap was caused by an invalid accumulator shift
0 = Math error trap was not caused by an invalid accumulator shift
- bit 6 **DIV0ERR:** Divide-by-Zero Error Status bit
1 = Math error trap was caused by a divide-by-zero
0 = Math error trap was not caused by a divide-by-zero
- bit 5 **DMACERR:** DMA Controller Trap Flag bit
1 = DMA Controller trap has occurred
0 = DMA Controller trap has not occurred
- bit 4 **MATHERR:** Math Error Status bit
1 = Math error trap has occurred
0 = Math error trap has not occurred

REGISTER 7-3: INTCON1: INTERRUPT CONTROL REGISTER 1 (CONTINUED)

- bit 3 **ADDRERR:** Address Error Trap Status bit
 1 = Address error trap has occurred
 0 = Address error trap has not occurred
- bit 2 **STKERR:** Stack Error Trap Status bit
 1 = Stack error trap has occurred
 0 = Stack error trap has not occurred
- bit 1 **OSCFAIL:** Oscillator Failure Trap Status bit
 1 = Oscillator failure trap has occurred
 0 = Oscillator failure trap has not occurred
- bit 0 **Unimplemented:** Read as '0'

REGISTER 7-4: INTCON2: INTERRUPT CONTROL REGISTER 2

R/W-1	R/W-0	R/W-0	U-0	U-0	U-0	U-0	U-0
GIE	DISI	SWTRAP	—	—	—	—	—
bit 15							bit 8

U-0	U-0	U-0	U-0	U-0	R/W-0	R/W-0	R/W-0
—	—	—	—	—	INT2EP	INT1EP	INT0EP
bit 7							bit 0

Legend:

R = Readable bit	W = Writable bit	U = Unimplemented bit, read as '0'
-n = Value at POR	'1' = Bit is set	'0' = Bit is cleared
		x = Bit is unknown

- bit 15 **GIE:** Global Interrupt Enable bit
 1 = Interrupts and associated IECx bits are enabled
 0 = Interrupts are disabled, but traps are still enabled
- bit 14 **DISI:** DISI Instruction Status bit
 1 = DISI instruction is active
 0 = DISI instruction is not active
- bit 13 **SWTRAP:** Software Trap Status bit
 1 = Software trap is enabled
 0 = Software trap is disabled
- bit 12-3 **Unimplemented:** Read as '0'
- bit 2 **INT2EP:** External Interrupt 2 Edge Detect Polarity Select bit
 1 = Interrupt on negative edge
 0 = Interrupt on positive edge
- bit 1 **INT1EP:** External Interrupt 1 Edge Detect Polarity Select bit
 1 = Interrupt on negative edge
 0 = Interrupt on positive edge
- bit 0 **INT0EP:** External Interrupt 0 Edge Detect Polarity Select bit
 1 = Interrupt on negative edge
 0 = Interrupt on positive edge

dsPIC33EPXXXGM3XX/6XX/7XX

REGISTER 7-5: INTCON3: INTERRUPT CONTROL REGISTER 3

U-0	U-0	U-0	U-0	U-0	U-0	U-0	U-0
—	—	—	—	—	—	—	—
bit 15							bit 8

U-0	U-0	R/W-0	R/W-0	U-0	U-0	U-0	U-0
—	—	DAE	DOOVR	—	—	—	—
bit 7							bit 0

Legend:

R = Readable bit W = Writable bit U = Unimplemented bit, read as '0'
 -n = Value at POR '1' = Bit is set '0' = Bit is cleared x = Bit is unknown

- bit 15-6 **Unimplemented:** Read as '0'
- bit 5 **DAE:** DMA Address Error Soft Trap Status bit
 1 = DMA address error soft trap has occurred
 0 = DMA address error soft trap has not occurred
- bit 4 **DOOVR:** DO Stack Overflow Soft Trap Status bit
 1 = DO stack overflow soft trap has occurred
 0 = DO stack overflow soft trap has not occurred
- bit 3-0 **Unimplemented:** Read as '0'

REGISTER 7-6: INTCON4: INTERRUPT CONTROL REGISTER 4

U-0	U-0	U-0	U-0	U-0	U-0	U-0	U-0
—	—	—	—	—	—	—	—
bit 15							bit 8

U-0	U-0	U-0	U-0	U-0	U-0	U-0	R/W-0
—	—	—	—	—	—	—	SGHT
bit 7							bit 0

Legend:

R = Readable bit W = Writable bit U = Unimplemented bit, read as '0'
 -n = Value at POR '1' = Bit is set '0' = Bit is cleared x = Bit is unknown

- bit 15-1 **Unimplemented:** Read as '0'
- bit 0 **SGHT:** Software Generated Hard Trap Status bit
 1 = Software generated hard trap has occurred
 0 = Software generated hard trap has not occurred

dsPIC33EPXXXGM3XX/6XX/7XX

REGISTER 7-7: INTTREG: INTERRUPT CONTROL AND STATUS REGISTER

U-0	U-0	U-0	U-0	R-0	R-0	R-0	R-0
—	—	—	—	ILR3	ILR2	ILR1	ILR0
bit 15				bit 8			

R-0	R-0	R-0	R-0	R-0	R-0	R-0	R-0
VECNUM7	VECNUM6	VECNUM5	VECNUM4	VECNUM3	VECNUM2	VECNUM1	VECNUM0
bit 7							bit 0

Legend:			
R = Readable bit	W = Writable bit	U = Unimplemented bit, read as '0'	
-n = Value at POR	'1' = Bit is set	'0' = Bit is cleared	x = Bit is unknown

- bit 15-12 **Unimplemented:** Read as '0'
- bit 11-8 **ILR<3:0>:** New CPU Interrupt Priority Level bits
 - 1111 = CPU Interrupt Priority Level is 15
 -
 -
 -
 - 0001 = CPU Interrupt Priority Level is 1
 - 0000 = CPU Interrupt Priority Level is 0
- bit 7-0 **VECNUM<7:0>:** Vector Number of Pending Interrupt bits
 - 11111111 = 255, Reserved; do not use
 -
 -
 -
 - 00001001 = 9, IC1 – Input Capture 1
 - 00001000 = 8, INTO – External Interrupt 0
 - 00000111 = 7, Reserved; do not use
 - 00000110 = 6, Generic soft error trap
 - 00000101 = 5, DMA Controller error trap
 - 00000100 = 4, Math error trap
 - 00000011 = 3, Stack error trap
 - 00000010 = 2, Generic hard trap
 - 00000001 = 1, Address error trap
 - 00000000 = 0, Oscillator fail trap

dsPIC33EPXXGM3XX/6XX/7XX

NOTES:

8.0 DIRECT MEMORY ACCESS (DMA)

Note 1: This data sheet summarizes the features of the dsPIC33EPXXXGM3XX/6XX/7XX family of devices. It is not intended to be a comprehensive reference source. To complement the information in this data sheet, refer to the “dsPIC33/PIC24 Family Reference Manual”, “**Direct Memory Access (DMA)**” (DS70348), which is available from the Microchip web site (www.microchip.com).

2: Some registers and associated bits described in this section may not be available on all devices. Refer to [Section 4.0 “Memory Organization”](#) in this data sheet for device-specific register and bit information.

The DMA Controller transfers data between Peripheral Data registers and Data Space SRAM

In addition, DMA can access the entire data memory space. The data memory bus arbiter is utilized when either the CPU or DMA attempts to access SRAM, resulting in potential DMA or CPU stalls.

The DMA Controller supports 4 independent channels. Each channel can be configured for transfers to or from selected peripherals. The peripherals supported by the DMA Controller include:

- CAN
- Analog-to-Digital Converter (ADC)
- Serial Peripheral Interface (SPI)
- UART
- Input Capture
- Output Compare
- DCI
- PMP
- Timers

Refer to [Table 8-1](#) for a complete list of supported peripherals.

FIGURE 8-1: PERIPHERAL TO DMA CONTROLLER

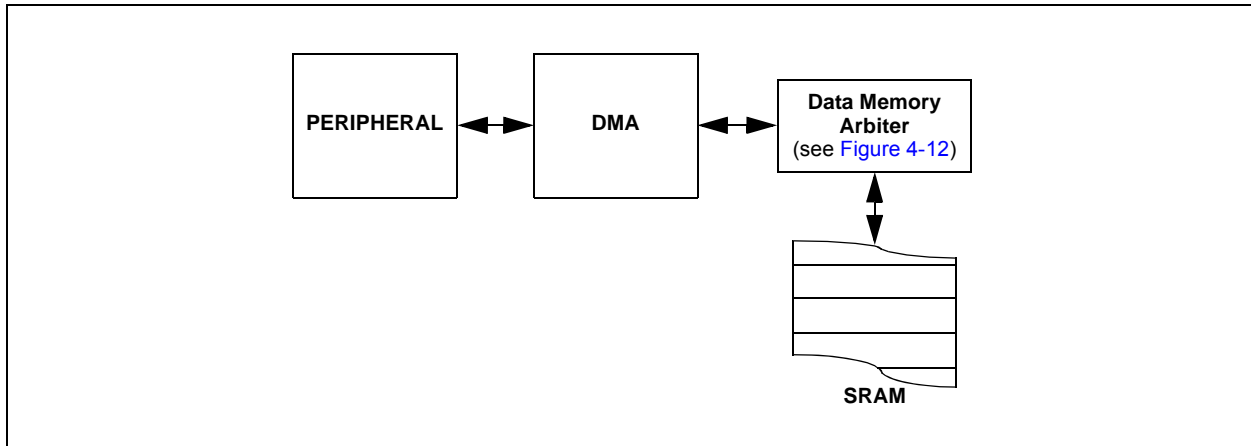

dsPIC33EPXXXGM3XX/6XX/7XX

In addition, DMA transfers can be triggered by timers as well as external interrupts. Each DMA channel is unidirectional. Two DMA channels must be allocated to read and write to a peripheral. If more than one channel receives a request to transfer data, a simple fixed priority scheme, based on channel number, dictates which channel completes the transfer and which channel, or channels, are left pending. Each DMA channel moves a block of data, after which, it generates an interrupt to the CPU to indicate that the block is available for processing.

The DMA Controller provides these functional capabilities:

- Four DMA channels
- Register Indirect with Post-increment Addressing mode
- Register Indirect without Post-increment Addressing mode

- Peripheral Indirect Addressing mode (peripheral generates destination address)
- CPU interrupt after half or full block transfer complete
- Byte or word transfers
- Fixed priority channel arbitration
- Manual (software) or automatic (peripheral DMA requests) transfer initiation
- One-Shot or Auto-Repeat Block Transfer modes
- Ping-Pong mode (automatic switch between two SRAM Start addresses after each block transfer complete)
- DMA request for each channel can be selected from any supported interrupt source
- Debug support features

The peripherals that can utilize DMA are listed in [Table 8-1](#).

TABLE 8-1: DMA CHANNEL TO PERIPHERAL ASSOCIATIONS

Peripheral to DMA Association	DMAxREQ Register IRQSEL<7:0> Bits	DMAxPAD Register (Values to Read from Peripheral)	DMAxPAD Register (Values to Write to Peripheral)
INT0 – External Interrupt 0	00000000	—	—
IC1 – Input Capture 1	00000001	0x0144 (IC1BUF)	—
IC2 – Input Capture 2	00000101	0x014C (IC2BUF)	—
IC3 – Input Capture 3	00100101	0x0154 (IC3BUF)	—
IC4 – Input Capture 4	00100110	0x015C (IC4BUF)	—
OC1 – Output Compare 1	00000010	—	0x0906 (OC1R) 0x0904 (OC1RS)
OC2 – Output Compare 2	00000110	—	0x0910 (OC2R) 0x090E (OC2RS)
OC3 – Output Compare 3	00011001	—	0x091A (OC3R) 0x0918 (OC3RS)
OC4 – Output Compare 4	00011010	—	0x0924 (OC4R) 0x0922 (OC4RS)
TMR2 – Timer2	00000111	—	—
TMR3 – Timer3	00001000	—	—
TMR4 – Timer4	00011011	—	—
TMR5 – Timer5	00011100	—	—
SPI1 Transfer Done	00001010	0x0248 (SPI1BUF)	0x0248 (SPI1BUF)
SPI2 Transfer Done	00100001	0x0268 (SPI2BUF)	0x0268 (SPI2BUF)
SPI3 Transfer Done	01011011	0x02A8(SPI3BUF)	0x02A8(SPI3BUF)
UART1RX – UART1 Receiver	00001011	0x0226 (U1RXREG)	—
UART1TX – UART1 Transmitter	00001100	—	0x0224 (U1TXREG)
UART2RX – UART2 Receiver	00011110	0x0236 (U2RXREG)	—
UART2TX – UART2 Transmitter	00011111	—	0x0234 (U2TXREG)
UART3RX – UART3 Receiver	01010010	0X0256(U3RXREG)	—
UART3TX – UART3 Transmitter	01010011	—	0X0254(U3TXREG)
UART4RX – UART4 Receiver	01011000	0X02B6(U4RXREG)	—
UART4TX – UART4 Transmitter	01011001	—	0X02B4(U4TXREG)

TABLE 8-1: DMA CHANNEL TO PERIPHERAL ASSOCIATIONS (CONTINUED)

Peripheral to DMA Association	DMAxREQ Register IRQSEL<7:0> Bits	DMAxPAD Register (Values to Read from Peripheral)	DMAxPAD Register (Values to Write to Peripheral)
CAN1 – RX Data Ready	00100010	0x0440 (C1RXD)	—
CAN1 – TX Data Request	01000110	—	0x0442 (C1TXD)
CAN2 – RX Data Ready	00110111	0X0540(C2RXD)	—
CAN2 – TX Data Request	01000111	—	0X0542(C2TXD)
DCI – Codec Transfer Done	00111100	0X0290(RXBUF0)	0X0298(TXBUF0)
ADC1 – ADC1 Convert Done	00001101	0x0300 (ADC1BUF0)	—
ADC2 – ADC2 Convert Done	00010101	0X0340(ADC2BUF0)	—
PMP – PMP Data Move	00101101	0X0608(PMPDAT1)	0X0608(PMPDAT1)

FIGURE 8-2: DMA CONTROLLER BLOCK DIAGRAM

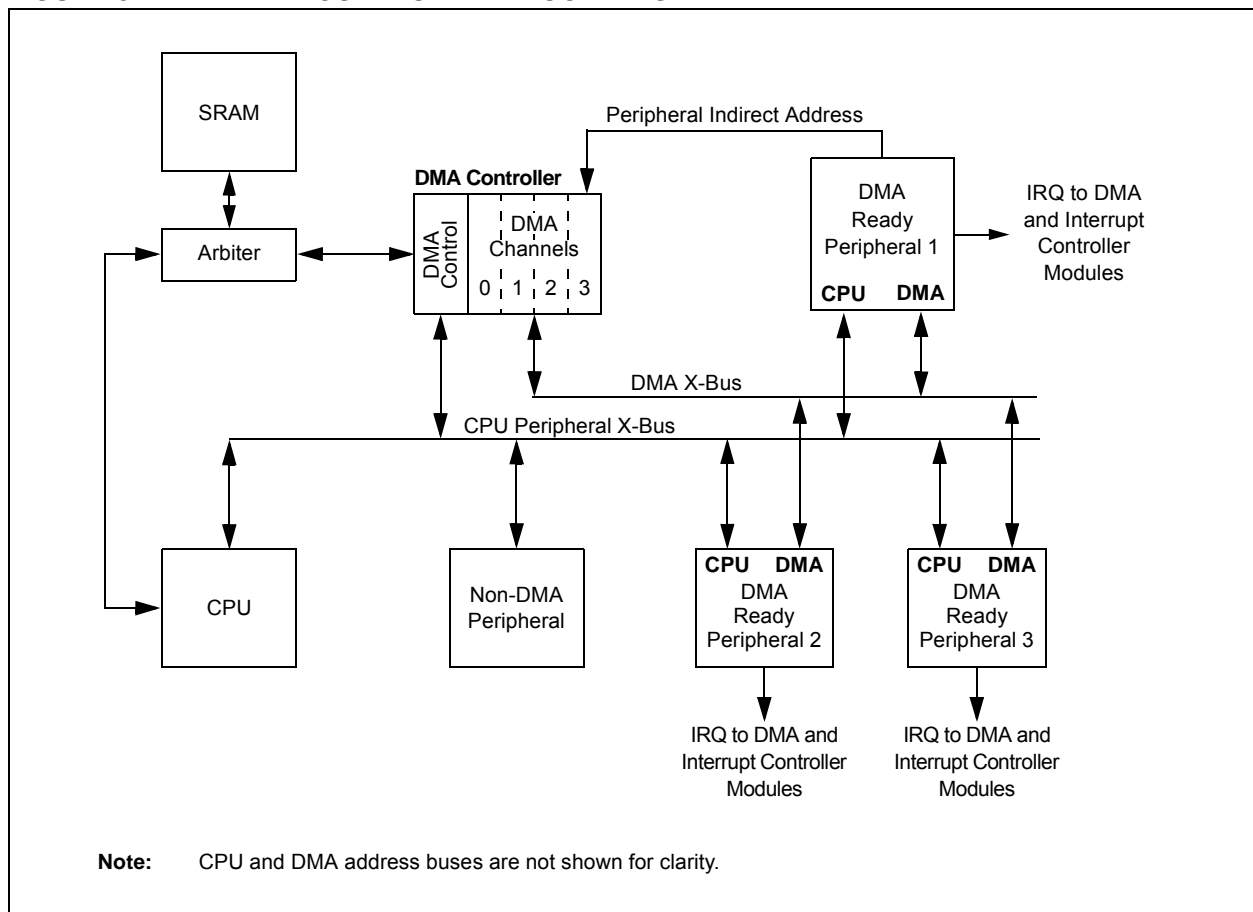

dsPIC33EPXXXGM3XX/6XX/7XX

8.1 DMA Controller Registers

Each DMA Controller Channel x (where x = 0 through 3) contains the following registers:

- 16-bit DMA Channel x Control Register (DMAxCON)
- 16-bit DMA Channel x IRQ Select Register (DMAxREQ)
- 32-bit DMA Channel x Start Address Register A (DMAxSTAL/H)
- 32-bit DMA Channel x Start Address Register B (DMAxSTBL/H)
- 16-bit DMA Channel x Peripheral Address Register (DMAxPAD)
- 14-bit DMA Channel x Transfer Count Register (DMAxCNT)

Additional status registers (DMAPWC, DMARQC, DMAPPS, DMALCA and DSADRL/H) are common to all DMA Controller channels. These status registers provide information on write and request collisions, as well as on last address and channel access information.

The interrupt flags (DMAxIF) are located in an IFSx register in the interrupt controller. The corresponding interrupt enable control bits (DMAxIE) are located in an IECx register in the interrupt controller and the corresponding interrupt priority control bits (DMAxIP) are located in an IPCx register in the interrupt controller.

REGISTER 8-1: DMAxCON: DMA CHANNEL x CONTROL REGISTER

R/W-0	R/W-0	R/W-0	R/W-0	R/W-0	U-0	U-0	U-0
CHEN	SIZE	DIR	HALF	NULLW	—	—	—
bit 15					bit 8		
U-0	U-0	R/W-0	R/W-0	U-0	U-0	R/W-0	R/W-0
—	—	AMODE1	AMODE0	—	—	MODE1	MODE0
bit 7					bit 0		

Legend:

R = Readable bit W = Writable bit U = Unimplemented bit, read as '0'
 -n = Value at POR '1' = Bit is set '0' = Bit is cleared x = Bit is unknown

- bit 15 **CHEN:** Channel Enable bit
 1 = Channel is enabled
 0 = Channel is disabled
- bit 14 **SIZE:** Data Transfer Size bit
 1 = Byte
 0 = Word
- bit 13 **DIR:** Transfer Direction bit (source/destination bus select)
 1 = Reads from RAM address, writes to peripheral address
 0 = Reads from peripheral address, writes to RAM address
- bit 12 **HALF:** Block Transfer Interrupt Select bit
 1 = Initiates interrupt when half of the data has been moved
 0 = Initiates interrupt when all of the data has been moved
- bit 11 **NULLW:** Null Data Peripheral Write Mode Select bit
 1 = Null data write to peripheral in addition to RAM write (DIR bit must also be clear)
 0 = Normal operation
- bit 10-6 **Unimplemented:** Read as '0'
- bit 5-4 **AMODE<1:0>:** DMA Channel Addressing Mode Select bits
 11 = Reserved
 10 = Peripheral Indirect mode
 01 = Register Indirect without Post-Increment mode
 00 = Register Indirect with Post-Increment mode
- bit 3-2 **Unimplemented:** Read as '0'
- bit 1-0 **MODE<1:0>:** DMA Channel Operating Mode Select bits
 11 = One-Shot, Ping-Pong modes are enabled (one block transfer from/to each DMA buffer)
 10 = Continuous, Ping-Pong modes are enabled
 01 = One-Shot, Ping-Pong modes are disabled
 00 = Continuous, Ping-Pong modes are disabled

dsPIC33EPXXXGM3XX/6XX/7XX

REGISTER 8-2: DMAxREQ: DMA CHANNEL x IRQ SELECT REGISTER

R/S-0	U-0	U-0	U-0	U-0	U-0	U-0	U-0
FORCE ⁽¹⁾	—	—	—	—	—	—	—
bit 15							bit 8

R/W-0	R/W-0	R/W-0	R/W-0	R/W-0	R/W-0	R/W-0	R/W-0
IRQSEL7	IRQSEL6	IRQSEL5	IRQSEL4	IRQSEL3	IRQSEL2	IRQSEL1	IRQSEL0
bit 7							bit 0

Legend:	S = Settable bit
R = Readable bit	W = Writable bit
-n = Value at POR	'1' = Bit is set
	U = Unimplemented bit, read as '0'
	'0' = Bit is cleared
	x = Bit is unknown

- bit 15 **FORCE:** Force DMA Transfer bit⁽¹⁾
 1 = Forces a single DMA transfer (Manual mode)
 0 = Automatic DMA transfer initiation by DMA request
- bit 14-8 **Unimplemented:** Read as '0'
- bit 7-0 **IRQSEL<7:0>:** DMA Peripheral IRQ Number Select bits
- 01011011 = SPI3 – Transfer done
 - 01011001 = UART4TX – UART4 transmitter
 - 01011000 = UART4RX – UART4 receiver
 - 01010011 = UART3TX – UART3 transmitter
 - 01010010 = UART3RX – UART3 receiver
 - 01000111 = CAN2 – TX data request
 - 01000110 = CAN1 – TX data request
 - 00111100 = DCI – Codec transfer done
 - 00110111 = CAN2 – RX data ready
 - 00101101 = PMP – PMP data move
 - 00100110 = IC4 – Input Capture 4
 - 00100101 = IC3 – Input Capture 3
 - 00100010 = CAN1 – RX data ready
 - 00100001 = SPI2 – SPI2 transfer done
 - 00011111 = UART2TX – UART2 transmitter
 - 00011110 = UART2RX – UART2 receiver
 - 00011100 = TMR5 – Timer5
 - 00011011 = TMR4 – Timer4
 - 00011010 = OC4 – Output Compare 4
 - 00011001 = OC3 – Output Compare 3
 - 00010101 = ADC2 – ADC2 convert done
 - 00001101 = ADC1 – ADC1 convert done
 - 00001100 = UART1TX – UART1 transmitter
 - 00001011 = UART1RX – UART1 receiver
 - 00001010 = SPI1 – SPI1 transfer done
 - 00001000 = TMR3 – Timer3
 - 00000111 = TMR2 – Timer2
 - 00000110 = OC2 – Output Compare 2
 - 00000101 = IC2 – Input Capture 2
 - 00000010 = OC1 – Output Compare 1
 - 00000001 = IC1 – Input Capture 1
 - 00000000 = INT0 – External Interrupt 0

Note 1: The FORCE bit cannot be cleared by user software. The FORCE bit is cleared by hardware when the forced DMA transfer is complete or the channel is disabled (CHEN = 0).

dsPIC33EPXXXGM3XX/6XX/7XX

REGISTER 8-3: DMAxSTAH: DMA CHANNEL x START ADDRESS REGISTER A (HIGH)

U-0	U-0	U-0	U-0	U-0	U-0	U-0	U-0
—	—	—	—	—	—	—	—
bit 15							bit 8

R/W-0	R/W-0	R/W-0	R/W-0	R/W-0	R/W-0	R/W-0	R/W-0
STA<23:16>							
bit 7							bit 0

Legend:

R = Readable bit W = Writable bit U = Unimplemented bit, read as '0'
 -n = Value at POR '1' = Bit is set '0' = Bit is cleared x = Bit is unknown

bit 15-8 **Unimplemented:** Read as '0'
 bit 7-0 **STA<23:16>:** DMA Primary Start Address bits (source or destination)

REGISTER 8-4: DMAxSTAL: DMA CHANNEL x START ADDRESS REGISTER A (LOW)

R/W-0	R/W-0	R/W-0	R/W-0	R/W-0	R/W-0	R/W-0	R/W-0
STA<15:8>							
bit 15							bit 8

R/W-0	R/W-0	R/W-0	R/W-0	R/W-0	R/W-0	R/W-0	R/W-0
STA<7:0>							
bit 7							bit 0

Legend:

R = Readable bit W = Writable bit U = Unimplemented bit, read as '0'
 -n = Value at POR '1' = Bit is set '0' = Bit is cleared x = Bit is unknown

bit 15-0 **STA<15:0>:** DMA Primary Start Address bits (source or destination)

dsPIC33EPXXXGM3XX/6XX/7XX

REGISTER 8-5: DMAxSTBH: DMA CHANNEL x START ADDRESS REGISTER B (HIGH)

U-0	U-0	U-0	U-0	R/W-0	U-0	U-0	U-0
—	—	—	—	—	—	—	—
bit 15							bit 8

R/W-0	R/W-0	R/W-0	R/W-0	R/W-0	R/W-0	R/W-0	R/W-0
STB<23:16>							
bit 7							bit 0

Legend:

R = Readable bit

W = Writable bit

U = Unimplemented bit, read as '0'

-n = Value at POR

'1' = Bit is set

'0' = Bit is cleared

x = Bit is unknown

bit 15-8 **Unimplemented:** Read as '0'

bit 7-0 **STB<23:16>:** DMA Secondary Start Address bits (source or destination)

REGISTER 8-6: DMAxSTBL: DMA CHANNEL x START ADDRESS REGISTER B (LOW)

R/W-0	R/W-0	R/W-0	R/W-0	R/W-0	R/W-0	R/W-0	R/W-0
STB<15:8>							
bit 15							bit 8

R/W-0	R/W-0	R/W-0	R/W-0	R/W-0	R/W-0	R/W-0	R/W-0
STB<7:0>							
bit 7							bit 0

Legend:

R = Readable bit

W = Writable bit

U = Unimplemented bit, read as '0'

-n = Value at POR

'1' = Bit is set

'0' = Bit is cleared

x = Bit is unknown

bit 15-0 **STB<15:0>:** DMA Secondary Start Address bits (source or destination)

dsPIC33EPXXXGM3XX/6XX/7XX

REGISTER 8-7: DMAxPAD: DMA CHANNEL x PERIPHERAL ADDRESS REGISTER⁽¹⁾

R/W-0	R/W-0	R/W-0	R/W-0	R/W-0	R/W-0	R/W-0	R/W-0
PAD<15:8>							
bit 15							bit 8

R/W-0	R/W-0	R/W-0	R/W-0	R/W-0	R/W-0	R/W-0	R/W-0
PAD<7:0>							
bit 7							bit 0

Legend:

R = Readable bit W = Writable bit U = Unimplemented bit, read as '0'
 -n = Value at POR '1' = Bit is set '0' = Bit is cleared x = Bit is unknown

bit 15-0 **PAD<15:0>**: DMA Peripheral Address Register bits

Note 1: If the channel is enabled (i.e., active), writes to this register may result in unpredictable behavior of the DMA channel and should be avoided.

REGISTER 8-8: DMAxCNT: DMA CHANNEL x TRANSFER COUNT REGISTER⁽¹⁾

U-0	U-0	R/W-0	R/W-0	R/W-0	R/W-0	R/W-0	R/W-0
—	—	CNT<13:8> ⁽²⁾					
bit 15							bit 8

R/W-0	R/W-0	R/W-0	R/W-0	R/W-0	R/W-0	R/W-0	R/W-0
CNT<7:0> ⁽²⁾							
bit 7							bit 0

Legend:

R = Readable bit W = Writable bit U = Unimplemented bit, read as '0'
 -n = Value at POR '1' = Bit is set '0' = Bit is cleared x = Bit is unknown

bit 15-14 **Unimplemented:** Read as '0'

bit 13-0 **CNT<13:0>**: DMA Transfer Count Register bits⁽²⁾

Note 1: If the channel is enabled (i.e., active), writes to this register may result in unpredictable behavior of the DMA channel and should be avoided.

2: The number of DMA transfers = CNT<13:0> + 1.

dsPIC33EPXXXGM3XX/6XX/7XX

REGISTER 8-9: DSADRH: DMA MOST RECENT RAM HIGH ADDRESS REGISTER

U-0	U-0	U-0	U-0	U-0	U-0	U-0	U-0
—	—	—	—	—	—	—	—
bit 15							bit 8

R-0	R-0	R-0	R-0	R-0	R-0	R-0	R-0
DSADR<23:16>							
bit 7							bit 0

Legend:

R = Readable bit W = Writable bit U = Unimplemented bit, read as '0'
 -n = Value at POR '1' = Bit is set '0' = Bit is cleared x = Bit is unknown

bit 15-8 **Unimplemented:** Read as '0'
 bit 7-0 **DSADR<23:16>:** Most Recent DMA Address Accessed by DMA bits

REGISTER 8-10: DSADRL: DMA MOST RECENT RAM LOW ADDRESS REGISTER

R-0	R-0	R-0	R-0	R-0	R-0	R-0	R-0
DSADR<15:8>							
bit 15							bit 8

R-0	R-0	R-0	R-0	R-0	R-0	R-0	R-0
DSADR<7:0>							
bit 7							bit 0

Legend:

R = Readable bit W = Writable bit U = Unimplemented bit, read as '0'
 -n = Value at POR '1' = Bit is set '0' = Bit is cleared x = Bit is unknown

bit 15-0 **DSADR<15:0>:** Most Recent DMA Address Accessed by DMA bits

dsPIC33EPXXXGM3XX/6XX/7XX

REGISTER 8-11: DMAPWC: DMA PERIPHERAL WRITE COLLISION STATUS REGISTER

U-0	U-0	U-0	U-0	U-0	U-0	U-0	U-0
—	—	—	—	—	—	—	—
bit 15							bit 8

U-0	U-0	U-0	U-0	R-0	R-0	R-0	R-0
—	—	—	—	PWCOL3	PWCOL2	PWCOL1	PWCOL0
bit 7							bit 0

Legend:

R = Readable bit W = Writable bit U = Unimplemented bit, read as '0'
 -n = Value at POR '1' = Bit is set '0' = Bit is cleared x = Bit is unknown

- bit 15-4 **Unimplemented:** Read as '0'
- bit 3 **PWCOL3:** Channel 3 Peripheral Write Collision Flag bit
 - 1 = Write collision is detected
 - 0 = No write collision is detected
- bit 2 **PWCOL2:** Channel 2 Peripheral Write Collision Flag bit
 - 1 = Write collision is detected
 - 0 = No write collision is detected
- bit 1 **PWCOL1:** Channel 1 Peripheral Write Collision Flag bit
 - 1 = Write collision is detected
 - 0 = No write collision is detected
- bit 0 **PWCOL0:** Channel 0 Peripheral Write Collision Flag bit
 - 1 = Write collision is detected
 - 0 = No write collision is detected

REGISTER 8-12: DMARQC: DMA REQUEST COLLISION STATUS REGISTER

U-0	U-0	U-0	U-0	U-0	U-0	U-0	U-0
—	—	—	—	—	—	—	—
bit 15							bit 8

U-0	U-0	U-0	U-0	R-0	R-0	R-0	R-0
—	—	—	—	RQCOL3	RQCOL2	RQCOL1	RQCOL0
bit 7							bit 0

Legend:			
R = Readable bit	W = Writable bit	U = Unimplemented bit, read as '0'	
-n = Value at POR	'1' = Bit is set	'0' = Bit is cleared	x = Bit is unknown

- bit 15-4 **Unimplemented:** Read as '0'
- bit 3 **RQCOL3:** Channel 3 Transfer Request Collision Flag bit
 1 = User FORCE and interrupt-based request collision are detected
 0 = No request collision is detected
- bit 2 **RQCOL2:** Channel 2 Transfer Request Collision Flag bit
 1 = User FORCE and interrupt-based request collision are detected
 0 = No request collision is detected
- bit 1 **RQCOL1:** Channel 1 Transfer Request Collision Flag bit
 1 = User FORCE and interrupt-based request collision are detected
 0 = No request collision is detected
- bit 0 **RQCOL0:** Channel 0 Transfer Request Collision Flag bit
 1 = User FORCE and interrupt-based request collision are detected
 0 = No request collision is detected

dsPIC33EPXXXGM3XX/6XX/7XX

REGISTER 8-13: DMALCA: DMA LAST CHANNEL ACTIVE STATUS REGISTER

U-0	U-0	U-0	U-0	U-0	U-0	U-0	U-0
—	—	—	—	—	—	—	—
bit 15						bit 8	

U-0	U-0	U-0	U-0	R-1	R-1	R-1	R-1
—	—	—	—	LSTCH<3:0>			
bit 7				bit 0			

Legend:

R = Readable bit	W = Writable bit	U = Unimplemented bit, read as '0'
-n = Value at POR	'1' = Bit is set	'0' = Bit is cleared
		x = Bit is unknown

bit 15-4 **Unimplemented:** Read as '0'

bit 3-0 **LSTCH<3:0>:** Last DMA Controller Channel Active Status bits

1111 = No DMA transfer has occurred since system Reset

1110 = Reserved

•

•

•

0100 = Reserved

0011 = Last data transfer was handled by Channel 3

0010 = Last data transfer was handled by Channel 2

0001 = Last data transfer was handled by Channel 1

0000 = Last data transfer was handled by Channel 0

REGISTER 8-14: DMAPPS: DMA PING-PONG STATUS REGISTER

U-0	U-0	U-0	U-0	U-0	U-0	U-0	U-0
—	—	—	—	—	—	—	—
bit 15							bit 8

U-0	U-0	U-0	U-0	R-0	R-0	R-0	R-0
—	—	—	—	PPST3	PPST2	PPST1	PPST0
bit 7							bit 0

Legend:			
R = Readable bit	W = Writable bit	U = Unimplemented bit, read as '0'	
-n = Value at POR	'1' = Bit is set	'0' = Bit is cleared	x = Bit is unknown

- bit 15-4 **Unimplemented:** Read as '0'
- bit 3 **PPST3:** Channel 3 Ping-Pong Mode Status Flag bit
 - 1 = DMA3STB register is selected
 - 0 = DMA3STA register is selected
- bit 2 **PPST2:** Channel 2 Ping-Pong Mode Status Flag bit
 - 1 = DMA2STB register is selected
 - 0 = DMA2STA register is selected
- bit 1 **PPST1:** Channel 1 Ping-Pong Mode Status Flag bit
 - 1 = DMA1STB register is selected
 - 0 = DMA1STA register is selected
- bit 0 **PPST0:** Channel 0 Ping-Pong Mode Status Flag bit
 - 1 = DMA0STB register is selected
 - 0 = DMA0STA register is selected

dsPIC33EPXXGM3XX/6XX/7XX

NOTES:

9.0 OSCILLATOR CONFIGURATION

Note 1: This data sheet summarizes the features of the dsPIC33EPXXXGM3XX/6XX/7XX family of devices. It is not intended to be a comprehensive reference source. To complement the information in this data sheet, refer to the “dsPIC33/PIC24 Family Reference Manual”, “Oscillator” (DS70580), which is available from the Microchip web site (www.microchip.com).

2: Some registers and associated bits described in this section may not be available on all devices. Refer to **Section 4.0 “Memory Organization”** in this data sheet for device-specific register and bit information.

The dsPIC33EPXXXGM3XX/6XX/7XX oscillator system provides:

- On-chip Phase-Locked Loop (PLL) to boost internal operating frequency on select internal and external oscillator sources
- On-the-fly clock switching between various clock sources
- Doze mode for system power savings
- Fail-Safe Clock Monitor (FSCM) that detects clock failure and permits safe application recovery or shutdown
- Configuration bits for clock source selection

A simplified diagram of the oscillator system is shown in **Figure 9-1**.

FIGURE 9-1: OSCILLATOR SYSTEM DIAGRAM

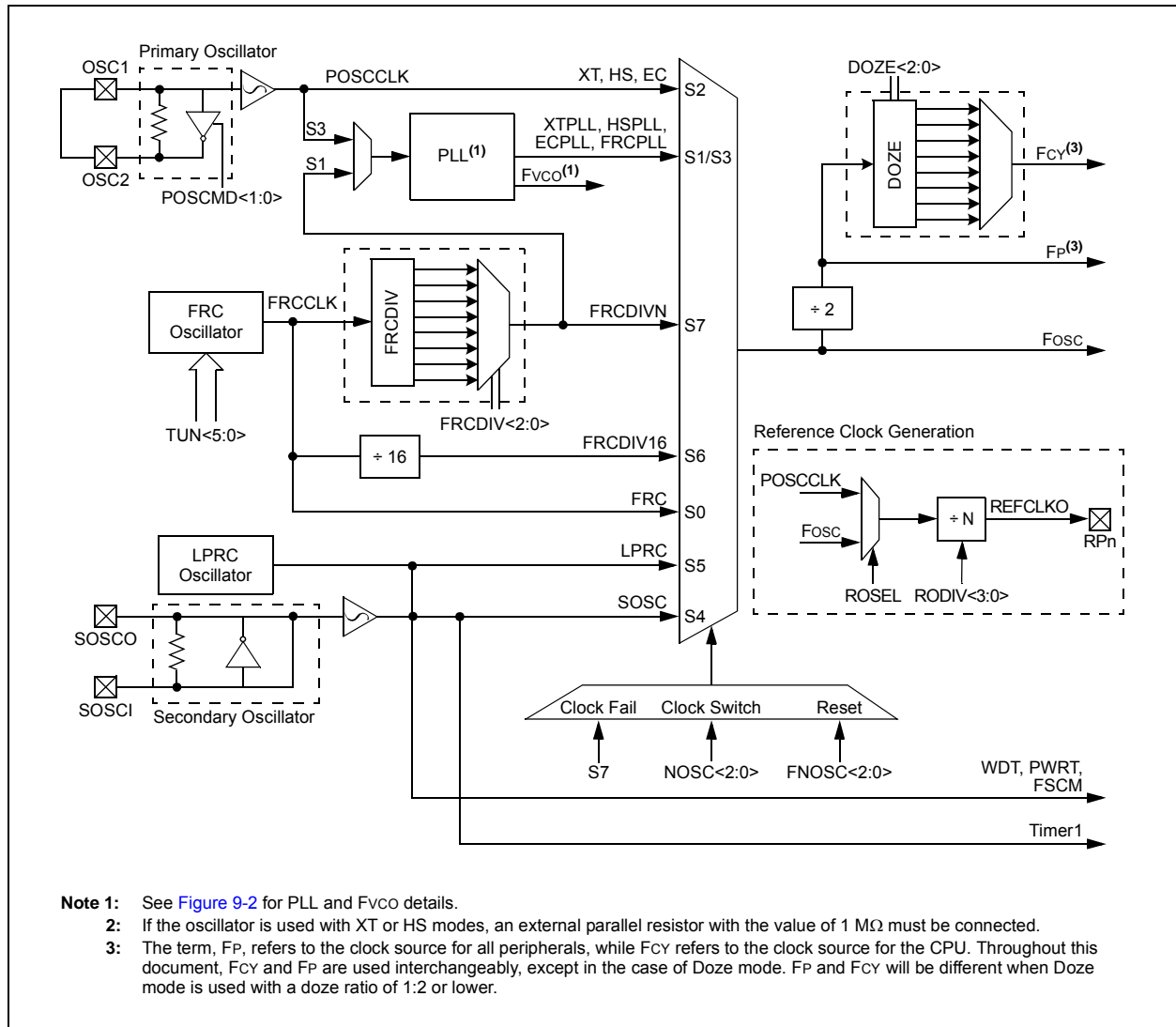

dsPIC33EPXXXGM3XX/6XX/7XX

9.1 CPU Clocking System

The dsPIC33EPXXXGM3XX/6XX/7XX family of devices provides seven system clock options:

- Fast RC (FRC) Oscillator
- FRC Oscillator with Phase-Locked Loop (PLL)
- FRC Oscillator with Postscaler
- Primary (XT, HS or EC) Oscillator
- Primary Oscillator with PLL
- Low-Power RC (LPRC) Oscillator
- Secondary (LP) Oscillator

Instruction execution speed or device operating frequency, F_{CY} , is given by [Equation 9-1](#).

EQUATION 9-1: DEVICE OPERATING FREQUENCY

$$F_{CY} = F_{OSC}/2$$

[Figure 9-2](#) is a block diagram of the PLL module.

[Equation 9-2](#) provides the relationship between input frequency (F_{IN}) and output frequency (F_{OSC}).

[Equation 9-3](#) provides the relationship between input frequency (F_{IN}) and VCO frequency (F_{SYS}).

FIGURE 9-2: PLL BLOCK DIAGRAM

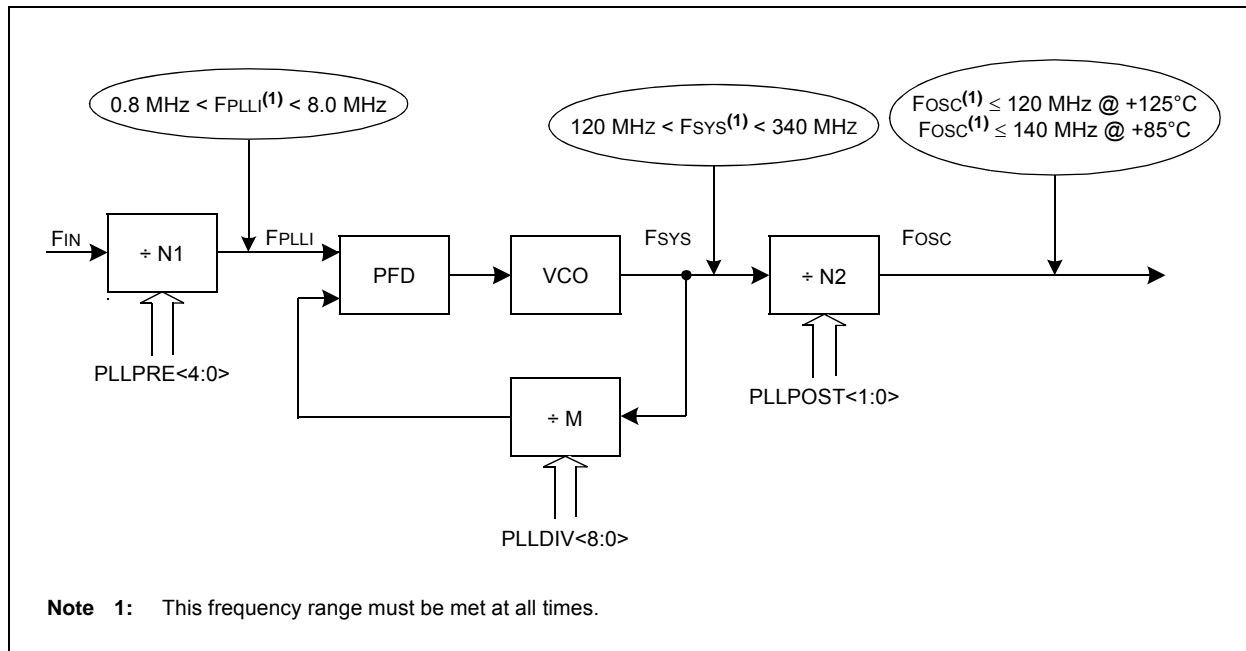

EQUATION 9-2: Fosc CALCULATION

$$F_{OSC} = F_{IN} \times \left(\frac{M}{N1 \times N2} \right) = F_{IN} \times \left(\frac{(PLLDIV<8:0> + 2)}{((PLLPRE<4:0> + 2) \times 2(PLLPOST<1:0> + 1))} \right)$$

Where:

$$N1 = PLLPRE<4:0> + 2$$

$$N2 = 2 \times (PLLPOST<1:0> + 1)$$

$$M = PLLDIV<8:0> + 2$$

EQUATION 9-3: Fvco CALCULATION

$$F_{SYS} = F_{IN} \times \left(\frac{M}{N1} \right) = F_{IN} \times \left(\frac{(PLLDIV<8:0> + 2)}{(PLLPRE<4:0> + 2)} \right)$$

TABLE 9-1: CONFIGURATION BIT VALUES FOR CLOCK SELECTION

Oscillator Mode	Oscillator Source	POSCMD<1:0>	FNOSC<2:0>	See Notes
Fast RC Oscillator with Divide-by-N (FRCDIVN)	Internal	xx	111	1, 2
Fast RC Oscillator with Divide-by-16 (FRCDIV16)	Internal	xx	110	1
Low-Power RC Oscillator (LPRC)	Internal	xx	101	1
Secondary (Timer1) Oscillator (SOSC)	Secondary	xx	100	1
Primary Oscillator (HS) with PLL (HSPLL)	Primary	10	011	
Primary Oscillator (XT) with PLL (XTPLL)	Primary	01	011	
Primary Oscillator (EC) with PLL (ECPLL)	Primary	00	011	1
Primary Oscillator (HS)	Primary	10	010	
Primary Oscillator (XT)	Primary	01	010	
Primary Oscillator (EC)	Primary	00	010	1
Fast RC Oscillator (FRC) with Divide-by-N and PLL (FRCPLL)	Internal	xx	001	1
Fast RC Oscillator (FRC)	Internal	xx	000	1

- Note 1:** OSC2 pin function is determined by the OSCIOFNC Configuration bit.
Note 2: This is the default oscillator mode for an unprogrammed (erased) device.

dsPIC33EPXXXGM3XX/6XX/7XX

REGISTER 9-1: OSCCON: OSCILLATOR CONTROL REGISTER^(1,3)

U-0	R-0	R-0	R-0	U-0	R/W-y	R/W-y	R/W-y
—	COSC2	COSC1	COSC0	—	NOSC2 ⁽²⁾	NOSC1 ⁽²⁾	NOSC0 ⁽²⁾
bit 15							bit 8

R/W-0	R/W-0	R-0	U-0	R/W-0	U-0	R/W-0	R/W-0
CLKLOCK	IOLOCK	LOCK	—	CF ⁽⁵⁾	—	LPOSCEN	OSWEN
bit 7							bit 0

Legend:	y = Value set from Configuration bits on POR		
R = Readable bit	W = Writable bit	U = Unimplemented bit, read as '0'	
-n = Value at POR	'1' = Bit is set	'0' = Bit is cleared	x = Bit is unknown

bit 15 **Unimplemented:** Read as '0'

bit 14-12 **COSC<2:0>:** Current Oscillator Selection bits (read-only)

- 111 = Fast RC Oscillator (FRC) with Divide-by-N
- 110 = Fast RC Oscillator (FRC) with Divide-by-16
- 101 = Low-Power RC Oscillator (LPRC)
- 100 = Secondary Oscillator (SOSC)⁽⁴⁾
- 011 = Primary Oscillator (MS, HS, EC) with PLL
- 010 = Primary Oscillator (MS, HS, EC)
- 001 = Fast RC Oscillator (FRC) Divided by N and PLL
- 000 = Fast RC Oscillator (FRC)

bit 11 **Unimplemented:** Read as '0'

bit 10-8 **NOSC<2:0>:** New Oscillator Selection bits⁽²⁾

- 111 = Fast RC Oscillator (FRC) with Divide-by-N
- 110 = Fast RC Oscillator (FRC) with Divide-by-16
- 101 = Low-Power RC Oscillator (LPRC)
- 100 = Secondary Oscillator (SOSC)⁽⁴⁾
- 011 = Primary Oscillator (MS, HS, EC) with PLL
- 010 = Primary Oscillator (MS, HS, EC)
- 001 = Fast RC Oscillator (FRC) Divided by N and PLL
- 000 = Fast RC Oscillator (FRC)

bit 7 **CLKLOCK:** Clock Lock Enable bit

- 1 = If FCKSM0 = 1, then clock and PLL configurations are locked; if FCKSM0 = 0, then clock and PLL configurations may be modified
- 0 = Clock and PLL selections are not locked, configurations may be modified

bit 6 **IOLOCK:** I/O Lock Enable bit

- 1 = I/O lock is active
- 0 = I/O lock is not active

- Note 1:** Writes to this register require an unlock sequence. Refer to the “dsPIC33/PIC24 Family Reference Manual”, “Oscillator” (DS70580), available from the Microchip web site for details.
- 2:** Direct clock switches between any primary oscillator mode with PLL and FRCPLL mode are not permitted. This applies to clock switches in either direction. In these instances, the application must switch to FRC mode as a transitional clock source between the two PLL modes.
- 3:** This register resets only on a Power-on Reset (POR).
- 4:** Secondary Oscillator (SOSC) selection is valid on 64-pin and 100-pin devices, and defaults to FRC/N on 44-pin devices.
- 5:** Only '0' should be written to the CF bit in order to clear it. If a '1' is written to CF, it will have the same effect as a detected clock failure, including an oscillator fail trap.

REGISTER 9-1: OSCCON: OSCILLATOR CONTROL REGISTER^(1,3) (CONTINUED)

bit 5	LOCK: PLL Lock Status bit (read-only) 1 = Indicates that PLL is in lock or PLL start-up timer is satisfied 0 = Indicates that PLL is out of lock, start-up timer is in progress or PLL is disabled
bit 4	Unimplemented: Read as '0'
bit 3	CF: Clock Fail Detect bit (read/clear by application) ⁽⁵⁾ 1 = FSCM has detected clock failure 0 = FSCM has not detected clock failure
bit 2	Unimplemented: Read as '0'
bit 1	LPOSCEN: Secondary (LP) Oscillator Enable bit 1 = Enables Secondary Oscillator (SOSC) 0 = Disables Secondary Oscillator
bit 0	OSWEN: Oscillator Switch Enable bit 1 = Requests oscillator switch to selection specified by the NOSC<2:0> bits 0 = Oscillator switch is complete

- Note 1:** Writes to this register require an unlock sequence. Refer to the “*dsPIC33/PIC24 Family Reference Manual*”, “**Oscillator**” (DS70580), available from the Microchip web site for details.
- 2:** Direct clock switches between any primary oscillator mode with PLL and FRCPLL mode are not permitted. This applies to clock switches in either direction. In these instances, the application must switch to FRC mode as a transitional clock source between the two PLL modes.
- 3:** This register resets only on a Power-on Reset (POR).
- 4:** Secondary Oscillator (SOSC) selection is valid on 64-pin and 100-pin devices, and defaults to FRC/N on 44-pin devices.
- 5:** Only '0' should be written to the CF bit in order to clear it. If a '1' is written to CF, it will have the same effect as a detected clock failure, including an oscillator fail trap.

dsPIC33EPXXXGM3XX/6XX/7XX

REGISTER 9-2: CLKDIV: CLOCK DIVISOR REGISTER⁽²⁾

R/W-0	R/W-0	R/W-1	R/W-1	R/W-0	R/W-0	R/W-0	R/W-0
ROI	DOZE2 ⁽³⁾	DOZE1 ⁽³⁾	DOZE0 ⁽³⁾	DOZEN ^(1,4)	FRCDIV2	FRCDIV1	FRCDIV0
bit 15							bit 8

R/W-0	R/W-1	U-0	R/W-0	R/W-0	R/W-0	R/W-0	R/W-0
PLLPOST1	PLLPOST0	—	PLLPRE4	PLLPRE3	PLLPRE2	PLLPRE1	PLLPRE0
bit 7							bit 0

Legend:

R = Readable bit W = Writable bit U = Unimplemented bit, read as '0'
 -n = Value at POR '1' = Bit is set '0' = Bit is cleared x = Bit is unknown

- bit 15 **ROI:** Recover on Interrupt bit
 1 = Interrupts will clear the DOZEN bit
 0 = Interrupts will have no effect on the DOZEN bit
- bit 14-12 **DOZE<2:0>:** Processor Clock Reduction Select bits⁽³⁾
 111 = Fcy divided by 128
 110 = Fcy divided by 64
 101 = Fcy divided by 32
 100 = Fcy divided by 16
 011 = Fcy divided by 8 (default)
 010 = Fcy divided by 4
 001 = Fcy divided by 2
 000 = Fcy divided by 1
- bit 11 **DOZEN:** Doze Mode Enable bit^(1,4)
 1 = DOZE<2:0> field specifies the ratio between the peripheral clocks and the processor clocks
 0 = Processor clock and peripheral clock ratio are forced to 1:1
- bit 10-8 **FRCDIV<2:0>:** Internal Fast RC Oscillator Postscaler bits
 111 = FRC divided by 256
 110 = FRC divided by 64
 101 = FRC divided by 32
 100 = FRC divided by 16
 011 = FRC divided by 8
 010 = FRC divided by 4
 001 = FRC divided by 2
 000 = FRC divided by 1 (default)
- bit 7-6 **PLLPOST<1:0>:** PLL VCO Output Divider Select bits (also denoted as 'N2', PLL postscaler)
 11 = Output divided by 8
 10 = Reserved
 01 = Output divided by 4 (default)
 00 = Output divided by 2
- bit 5 **Unimplemented:** Read as '0'

- Note 1:** This bit is cleared when the ROI bit is set and an interrupt occurs.
Note 2: This register resets only on a Power-on Reset (POR).
Note 3: The DOZE<2:0> bits can only be written to when the DOZEN bit is clear. If DOZEN = 1, any writes to DOZE<2:0> are ignored.
Note 4: The DOZEN bit cannot be set if DOZE<2:0> = 000. If DOZE<2:0> = 000, any attempt by user software to set the DOZEN bit is ignored.

REGISTER 9-2: CLKDIV: CLOCK DIVISOR REGISTER⁽²⁾ (CONTINUED)

bit 4-0 **PLLPRE<4:0>**: PLL Phase Detector Input Divider Select bits (also denoted as 'N1', PLL prescaler)

- 11111 = Input divided by 33
-
-
-
- 00001 = Input divided by 3
- 00000 = Input divided by 2 (default)

- Note 1:** This bit is cleared when the ROI bit is set and an interrupt occurs.
- Note 2:** This register resets only on a Power-on Reset (POR).
- Note 3:** The DOZE<2:0> bits can only be written to when the DOZEN bit is clear. If DOZEN = 1, any writes to DOZE<2:0> are ignored.
- Note 4:** The DOZEN bit cannot be set if DOZE<2:0> = 000. If DOZE<2:0> = 000, any attempt by user software to set the DOZEN bit is ignored.

dsPIC33EPXXXGM3XX/6XX/7XX

REGISTER 9-3: PLLFBD: PLL FEEDBACK DIVISOR REGISTER⁽¹⁾

U-0	U-0	U-0	U-0	U-0	U-0	U-0	R/W-0
—	—	—	—	—	—	—	PLLDIV<8>
bit 15							bit 8

R/W-0	R/W-0	R/W-1	R/W-1	R/W-0	R/W-0	R/W-0	R/W-0
PLLDIV<7:0>							
bit 7							bit 0

Legend:

R = Readable bit	W = Writable bit	U = Unimplemented bit, read as '0'
-n = Value at POR	'1' = Bit is set	'0' = Bit is cleared
		x = Bit is unknown

bit 15-9 **Unimplemented:** Read as '0'

bit 8-0 **PLLDIV<8:0>:** PLL Feedback Divisor bits (also denoted as 'M', PLL multiplier)

111111111 = 513

•

•

•

000110000 = 50 (default)

•

•

•

000000010 = 4

000000001 = 3

000000000 = 2

Note 1: This register is reset only on a Power-on Reset (POR).

dsPIC33EPXXXGM3XX/6XX/7XX

REGISTER 9-4: OSCTUN: FRC OSCILLATOR TUNING REGISTER⁽¹⁾

U-0	U-0	U-0	U-0	U-0	U-0	U-0	U-0
—	—	—	—	—	—	—	—
bit 15							bit 8

U-0	U-0	R/W-0	R/W-0	R/W-0	R/W-0	R/W-0	R/W-0
—	—	TUN<5:0>					
bit 7							bit 0

Legend:

R = Readable bit

W = Writable bit

U = Unimplemented bit, read as '0'

-n = Value at POR

'1' = Bit is set

'0' = Bit is cleared

x = Bit is unknown

bit 15-6

Unimplemented: Read as '0'

bit 5-0

TUN<5:0>: FRC Oscillator Tuning bits

111111 = Center frequency – 0.047%

•

•

•

100001 = Center frequency – 1.453%

100000 = Center frequency – 1.5% (7.355 MHz)

011111 = Center frequency + 1.5% (7.385 MHz)

011110 = Center frequency + 1.453%

•

•

•

000001 = Center frequency + 0.047%

000000 = Center frequency (7.3728 MHz nominal)

Note 1: This register resets only on a Power-on Reset (POR).

dsPIC33EPXXXGM3XX/6XX/7XX

REGISTER 9-5: REFOCON: REFERENCE OSCILLATOR CONTROL REGISTER

R/W-0	U-0	R/W-0	R/W-0	R/W-0	R/W-0	R/W-0	R/W-0
ROON	—	ROSSLP	ROSEL	RODIV3 ⁽¹⁾	RODIV2 ⁽¹⁾	RODIV1 ⁽¹⁾	RODIV0 ⁽¹⁾
bit 15							bit 8

U-0	U-0	U-0	U-0	U-0	U-0	U-0	U-0
—	—	—	—	—	—	—	—
bit 7							bit 0

Legend:

R = Readable bit W = Writable bit U = Unimplemented bit, read as '0'
 -n = Value at POR '1' = Bit is set '0' = Bit is cleared x = Bit is unknown

- bit 15 **ROON:** Reference Oscillator Output Enable bit
 1 = Reference oscillator output is enabled on the REFCLK pin⁽²⁾
 0 = Reference oscillator output is disabled
- bit 14 **Unimplemented:** Read as '0'
- bit 13 **ROSSLP:** Reference Oscillator Run in Sleep bit
 1 = Reference oscillator output continues to run in Sleep
 0 = Reference oscillator output is disabled in Sleep
- bit 12 **ROSEL:** Reference Oscillator Source Select bit
 1 = Oscillator crystal is used as the reference clock
 0 = System clock is used as the reference clock
- bit 11-8 **RODIV<3:0>:** Reference Oscillator Divider bits⁽¹⁾
 1111 = Reference clock divided by 32,768
 1110 = Reference clock divided by 16,384
 1101 = Reference clock divided by 8,192
 1100 = Reference clock divided by 4,096
 1011 = Reference clock divided by 2,048
 1010 = Reference clock divided by 1,024
 1001 = Reference clock divided by 512
 1000 = Reference clock divided by 256
 0111 = Reference clock divided by 128
 0110 = Reference clock divided by 64
 0101 = Reference clock divided by 32
 0100 = Reference clock divided by 16
 0011 = Reference clock divided by 8
 0010 = Reference clock divided by 4
 0001 = Reference clock divided by 2
 0000 = Reference clock
- bit 7-0 **Unimplemented:** Read as '0'

Note 1: The reference oscillator output must be disabled (ROON = 0) before writing to these bits.
Note 2: This pin is remappable. See **Section 11.4 “Peripheral Pin Select (PPS)”** for more information.

10.0 POWER-SAVING FEATURES

Note 1: This data sheet summarizes the features of the dsPIC33EPXXXGM3XX/6XX/7XX family of devices. It is not intended to be a comprehensive reference source. To complement the information in this data sheet, refer to the “*dsPIC33/PIC24 Family Reference Manual*”, “**Watchdog Timer and Power-Saving Modes**” (DS70615), which is available from the Microchip web site (www.microchip.com).

2: Some registers and associated bits described in this section may not be available on all devices. Refer to [Section 4.0 “Memory Organization”](#) in this data sheet for device-specific register and bit information.

The dsPIC33EPXXXGM3XX/6XX/7XX devices provide the ability to manage power consumption by selectively managing clocking to the CPU and the peripherals. In general, a lower clock frequency and a reduction in the number of peripherals being clocked constitutes lower consumed power.

The dsPIC33EPXXXGM3XX/6XX/7XX devices can manage power consumption in four ways:

- Clock Frequency
- Instruction-Based Sleep and Idle modes
- Software-Controlled Doze mode
- Selective Peripheral Control in Software

Combinations of these methods can be used to selectively tailor an application’s power consumption while still maintaining critical application features, such as timing-sensitive communications.

EXAMPLE 10-1: PWRSAV INSTRUCTION SYNTAX

```
PWRSAV #SLEEP_MODE    ; Put the device into Sleep mode
PWRSAV #IDLE_MODE     ; Put the device into Idle mode
```

10.1 Clock Frequency and Clock Switching

The dsPIC33EPXXXGM3XX/6XX/7XX devices allow a wide range of clock frequencies to be selected under application control. If the system clock configuration is not locked, users can choose low-power or high-precision oscillators by simply changing the NOSCx bits (OSCCON<10:8>). The process of changing a system clock during operation, as well as limitations to the process, are discussed in more detail in [Section 9.0 “Oscillator Configuration”](#).

10.2 Instruction-Based Power-Saving Modes

The dsPIC33EPXXXGM3XX/6XX/7XX devices have two special power-saving modes that are entered through the execution of a special PWRSAV instruction. Sleep mode stops clock operation and halts all code execution. Idle mode halts the CPU and code execution, but allows peripheral modules to continue operation. The assembler syntax of the PWRSAV instruction is shown in [Example 10-1](#).

Note: SLEEP_MODE and IDLE_MODE are constants defined in the Assembler Include file for the selected device.

Sleep and Idle modes can be exited as a result of an enabled interrupt, WDT time-out or a device Reset. When the device exits these modes, it is said to “wake-up”.

10.2.1 SLEEP MODE

The following occurs in Sleep mode:

- The system clock source is shut down. If an on-chip oscillator is used, it is turned off.
- The device current consumption is reduced to a minimum, provided that no I/O pin is sourcing current
- The Fail-Safe Clock Monitor does not operate, since the system clock source is disabled
- The LPRC clock continues to run in Sleep mode if the WDT is enabled
- The WDT, if enabled, is automatically cleared prior to entering Sleep mode
- Some device features or peripherals can continue to operate. This includes items such as the Input Change Notification (ICN) on the I/O ports or peripherals that use an external clock input.
- Any peripheral that requires the system clock source for its operation is disabled

The device wakes up from Sleep mode on any of the these events:

- Any interrupt source that is individually enabled
- Any form of device Reset
- A WDT time-out

On wake-up from Sleep mode, the processor restarts with the same clock source that was active when Sleep mode was entered.

For optimal power savings, the internal regulator and the Flash regulator can be configured to go into Standby mode when Sleep mode is entered by clearing the VREGS (RCON<8>) and VREGSF (RCON<11>) bits (default configuration).

If the application requires a faster wake-up time, and can accept higher current requirements, the VREGS (RCON<8>) and VREGSF (RCON<11>) bits can be set to keep the internal regulator and the Flash regulator active during Sleep mode.

10.2.2 IDLE MODE

The following occurs in Idle mode:

- The CPU stops executing instructions
- The WDT is automatically cleared
- The system clock source remains active. By default, all peripheral modules continue to operate normally from the system clock source, but can also be selectively disabled (see [Section 10.4 “Peripheral Module Disable”](#)).
- If the WDT or FSCM is enabled, the LPRC also remains active.

The device wakes from Idle mode on any of these events:

- Any interrupt that is individually enabled
- Any device Reset
- A WDT time-out

On wake-up from Idle mode, the clock is reapplied to the CPU and instruction execution will begin (2-4 clock cycles later), starting with the instruction following the `PWRSVAV` instruction or the first instruction in the Interrupt Service Routine (ISR).

All peripherals also have the option to discontinue operation when Idle mode is entered to allow for increased power savings. This option is selectable in the control register of each peripheral; for example, the TSIDL bit in the Timer1 Control register (T1CON<13>).

10.2.3 INTERRUPTS COINCIDENT WITH POWER SAVE INSTRUCTIONS

Any interrupt that coincides with the execution of a `PWRSVAV` instruction is held off until entry into Sleep or Idle mode has completed. The device then wakes up from Sleep or Idle mode.

10.3 Doze Mode

The preferred strategies for reducing power consumption are changing clock speed and invoking one of the power-saving modes. In some circumstances, this cannot be practical. For example, it may be necessary for an application to maintain uninterrupted synchronous communication, even while it is doing nothing else. Reducing system clock speed can introduce communication errors, while using a power-saving mode can stop communications completely.

Doze mode is a simple and effective alternative method to reduce power consumption while the device is still executing code. In this mode, the system clock continues to operate from the same source and at the same speed. Peripheral modules continue to be clocked at the same speed, while the CPU clock speed is reduced. Synchronization between the two clock domains is maintained, allowing the peripherals to access the SFRs while the CPU executes code at a slower rate.

Doze mode is enabled by setting the DOZEN bit (CLKDIV<11>). The ratio between peripheral and core clock speed is determined by the DOZE<2:0> bits (CLKDIV<14:12>). There are eight possible configurations, from 1:1 to 1:128, with 1:1 being the default setting.

Programs can use Doze mode to selectively reduce power consumption in event-driven applications. This allows clock-sensitive functions, such as synchronous communications, to continue without interruption while the CPU idles, waiting for something to invoke an interrupt routine. An automatic return to full-speed CPU operation on interrupts can be enabled by setting the ROI bit (CLKDIV<15>). By default, interrupt events have no effect on Doze mode operation.

For example, suppose the device is operating at 20 MIPS and the CAN module has been configured for 500 kbps based on this device operating speed. If the device is placed in Doze mode with a clock frequency ratio of 1:4, the CAN module continues to communicate at the required bit rate of 500 kbps, but the CPU now starts executing instructions at a frequency of 5 MIPS.

10.4 Peripheral Module Disable

The Peripheral Module Disable (PMD) registers provide a method to disable a peripheral module by stopping all clock sources supplied to that module. When a peripheral is disabled, using the appropriate PMD control bit, the peripheral is in a minimum power consumption state. The control and status registers associated with the peripheral are also disabled, so writes to those registers do not have effect and read values are invalid.

A peripheral module is enabled only if both the associated bit in the PMD register is cleared and the peripheral is supported by the specific dsPIC® DSC variant. If the peripheral is present in the device, it is enabled in the PMD register by default.

Note: If a PMD bit is set, the corresponding module is disabled after a delay of one instruction cycle. Similarly, if a PMD bit is cleared, the corresponding module is enabled after a delay of one instruction cycle (assuming the module control registers are already configured to enable module operation).
--

dsPIC33EPXXXGM3XX/6XX/7XX

REGISTER 10-1: PMD1: PERIPHERAL MODULE DISABLE CONTROL REGISTER 1

R/W-0	R/W-0	R/W-0	R/W-0	R/W-0	R/W-0	R/W-0	R/W-0
T5MD	T4MD	T3MD	T2MD	T1MD	QE11MD	PWMMD	DCIMD
bit 15						bit 8	

R/W-0	R/W-0	R/W-0	R/W-0	R/W-0	R/W-0	R/W-0	R/W-0
I2C1MD	U2MD	U1MD	SPI2MD	SPI1MD	C2MD ⁽¹⁾	C1MD ⁽¹⁾	AD1MD
bit 7						bit 0	

Legend:

R = Readable bit

W = Writable bit

U = Unimplemented bit, read as '0'

-n = Value at POR

'1' = Bit is set

'0' = Bit is cleared

x = Bit is unknown

bit 15 **T5MD:** Timer5 Module Disable bit

1 = Timer5 module is disabled

0 = Timer5 module is enabled

bit 14 **T4MD:** Timer4 Module Disable bit

1 = Timer4 module is disabled

0 = Timer4 module is enabled

bit 13 **T3MD:** Timer3 Module Disable bit

1 = Timer3 module is disabled

0 = Timer3 module is enabled

bit 12 **T2MD:** Timer2 Module Disable bit

1 = Timer2 module is disabled

0 = Timer2 module is enabled

bit 11 **T1MD:** Timer1 Module Disable bit

1 = Timer1 module is disabled

0 = Timer1 module is enabled

bit 10 **QE11MD:** QE11 Module Disable bit

1 = QE11 module is disabled

0 = QE11 module is enabled

bit 9 **PWMMD:** PWM Module Disable bit

1 = PWM module is disabled

0 = PWM module is enabled

bit 8 **DCIMD:** DCI Module Disable bit

1 = DCI module is disabled

0 = DCI module is enabled

bit 7 **I2C1MD:** I2C1 Module Disable bit

1 = I2C1 module is disabled

0 = I2C1 module is enabled

bit 6 **U2MD:** UART2 Module Disable bit

1 = UART2 module is disabled

0 = UART2 module is enabled

bit 5 **U1MD:** UART1 Module Disable bit

1 = UART1 module is disabled

0 = UART1 module is enabled

Note 1: These bits are available on dsPIC33EPXXXGM6XX/7XX devices only.

REGISTER 10-1: PMD1: PERIPHERAL MODULE DISABLE CONTROL REGISTER 1 (CONTINUED)

bit 4	SPI2MD: SPI2 Module Disable bit 1 = SPI2 module is disabled 0 = SPI2 module is enabled
bit 3	SPI1MD: SPI1 Module Disable bit 1 = SPI1 module is disabled 0 = SPI1 module is enabled
bit 2	C2MD: CAN2 Module Disable bit ⁽¹⁾ 1 = CAN2 module is disabled 0 = CAN2 module is enabled
bit 1	C1MD: CAN1 Module Disable bit ⁽¹⁾ 1 = CAN1 module is disabled 0 = CAN1 module is enabled
bit 0	AD1MD: ADC1 Module Disable bit 1 = ADC1 module is disabled 0 = ADC1 module is enabled

Note 1: These bits are available on dsPIC33EPXXXGM6XX/7XX devices only.

dsPIC33EPXXXGM3XX/6XX/7XX

REGISTER 10-2: PMD2: PERIPHERAL MODULE DISABLE CONTROL REGISTER 2

R/W-0	R/W-0	R/W-0	R/W-0	R/W-0	R/W-0	R/W-0	R/W-0
IC8MD	IC7MD	IC6MD	IC5MD	IC4MD	IC3MD	IC2MD	IC1MD
bit 15							bit 8

R/W-0	R/W-0	R/W-0	R/W-0	R/W-0	R/W-0	R/W-0	R/W-0
OC8MD	OC7MD	OC6MD	OC5MD	OC4MD	OC3MD	OC2MD	OC1MD
bit 7							bit 0

Legend:

R = Readable bit

W = Writable bit

U = Unimplemented bit, read as '0'

-n = Value at POR

'1' = Bit is set

'0' = Bit is cleared

x = Bit is unknown

bit 15-8 **IC8MD:IC1MD:** Input Capture x (x = 1-8) Module Disable bits

1 = Input Capture x module is disabled

0 = Input Capture x module is enabled

bit 7-0 **OC8MD:OC1MD:** Output Compare x (x = 1-8) Module Disable bits

1 = Output Compare x module is disabled

0 = Output Compare x module is enabled

REGISTER 10-3: PMD3: PERIPHERAL MODULE DISABLE CONTROL REGISTER 3

R/W-0	R/W-0	R/W-0	R/W-0	U-0	R/W-0	R/W-0	R/W-0
T9MD	T8MD	T7MD	T6MD	—	CMPMD	RTCCMD ⁽¹⁾	PMPMD
bit 15							bit 8

R/W-0	R/W-0	R/W-0	R/W-0	R/W-0	R/W-0	R/W-0	R/W-0
CRCMD	DACMD	QEI2MD	PWM2MD	U3MD	I2C3MD	I2C2MD	ADC2MD
bit 7							bit 0

Legend:

R = Readable bit	W = Writable bit	U = Unimplemented bit, read as '0'
-n = Value at POR	'1' = Bit is set	'0' = Bit is cleared
		x = Bit is unknown

- bit 15 **T9MD:** Timer9 Module Disable bit
1 = Timer9 module is disabled
0 = Timer9 module is enabled
- bit 13 **T8MD:** Timer8 Module Disable bit
1 = Timer8 module is disabled
0 = Timer8 module is enabled
- bit 14 **T7MD:** Timer7 Module Disable bit
1 = Timer7 module is disabled
0 = Timer7 module is enabled
- bit 12 **T6MD:** Timer6 Module Disable bit
1 = Timer6 module is disabled
0 = Timer6 module is enabled
- bit 11 **Unimplemented:** Read as '0'
- bit 10 **CMPMD:** Comparator Module Disable bit
1 = Comparator module is disabled
0 = Comparator module is enabled
- bit 9 **RTCCMD:** RTCC Module Disable bit⁽¹⁾
1 = RTCC module is disabled
0 = RTCC module is enabled
- bit 8 **PMPMD:** PMP Module Disable bit
1 = PMP module is disabled
0 = PMP module is enabled
- bit 7 **CRCMD:** CRC Module Disable bit
1 = CRC module is disabled
0 = CRC module is enabled
- bit 6 **DACMD:** DAC Module Disable bit
1 = DAC module is disabled
0 = DAC module is enabled
- bit 5 **QEI2MD:** QEI2 Module Disable bit
1 = QEI2 module is disabled
0 = QEI2 module is enabled
- bit 4 **PWM2MD:** PWM2 Module Disable bit
1 = PWM2 module is disabled
0 = PWM2 module is enabled

Note 1: The RTCCMD bit is not available on 44-pin devices.

dsPIC33EPXXXGM3XX/6XX/7XX

REGISTER 10-3: PMD3: PERIPHERAL MODULE DISABLE CONTROL REGISTER 3

- bit 3 **U3MD:** UART3 Module Disable bit
 1 = UART3 module is disabled
 0 = UART3 module is enabled
- bit 2 **I2C3MD:** I2C3 Module Disable bit
 1 = I2C3 module is disabled
 0 = I2C3 module is enabled
- bit 1 **I2C2MD:** I2C2 Module Disable bit
 1 = I2C2 module is disabled
 0 = I2C2 module is enabled
- bit 0 **ADC2MD:** ADC2 Module Disable bit
 1 = ADC2 module is disabled
 0 = ADC2 module is enabled

Note 1: The RTCCMD bit is not available on 44-pin devices.

REGISTER 10-4: PMD4: PERIPHERAL MODULE DISABLE CONTROL REGISTER 4

U-0	U-0	U-0	U-0	U-0	U-0	U-0	U-0
—	—	—	—	—	—	—	—
bit 15							bit 8

U-0	U-0	R/W-0	U-0	R/W-0	R/W-0	U-0	U-0
—	—	U4MD	—	REFOMD	CTMUMD	—	—
bit 7							bit 0

Legend:

R = Readable bit	W = Writable bit	U = Unimplemented bit, read as '0'
-n = Value at POR	'1' = Bit is set	'0' = Bit is cleared
		x = Bit is unknown

- bit 15-6 **Unimplemented:** Read as '0'
- bit 5 **U4MD:** UART4 Module Disable bit
 1 = UART4 module is disabled
 0 = UART4 module is enabled
- bit 4 **Unimplemented:** Read as '0'
- bit 3 **REFOMD:** Reference Clock Module Disable bit
 1 = Reference clock module is disabled
 0 = Reference clock module is enabled
- bit 2 **CTMUMD:** CTMU Module Disable bit
 1 = CTMU module is disabled
 0 = CTMU module is enabled
- bit 1-0 **Unimplemented:** Read as '0'

REGISTER 10-5: PMD6: PERIPHERAL MODULE DISABLE CONTROL REGISTER 6

U-0	U-0	R/W-0	R/W-0	R/W-0	R/W-0	R/W-0	R/W-0
—	—	PWM6MD	PWM5MD	PWM4MD	PWM3MD	PWM2MD	PWM1MD
bit 15							bit 8

U-0	U-0	U-0	U-0	U-0	U-0	U-0	R/W-0
—	—	—	—	—	—	—	SPI3MD
bit 7							bit 0

Legend:

R = Readable bit	W = Writable bit	U = Unimplemented bit, read as '0'
-n = Value at POR	'1' = Bit is set	'0' = Bit is cleared
		x = Bit is unknown

- bit 15-14 **Unimplemented:** Read as '0'
- bit 13-8 **PWM6MD:PWM1MD:** PWMx (x = 1-6) Module Disable bit
 1 = PWMx module is disabled
 0 = PWMx module is enabled
- bit 7-1 **Unimplemented:** Read as '0'
- bit 0 **SPI3MD:** SPI3 Module Disable bit
 1 = SPI3 module is disabled
 0 = SPI3 module is enabled

dsPIC33EPXXXGM3XX/6XX/7XX

REGISTER 10-6: PMD7: PERIPHERAL MODULE DISABLE CONTROL REGISTER 7

U-0	U-0	U-0	U-0	U-0	U-0	U-0	U-0
—	—	—	—	—	—	—	—
bit 15							bit 8

U-0	U-0	U-0	R/W-0	R/W-0	U-0	U-0	U-0
—	—	—	DMA0MD ⁽¹⁾	PTGMD	—	—	—
			DMA1MD ⁽¹⁾				
			DMA2MD ⁽¹⁾				
			DMA3MD ⁽¹⁾				
bit 7							bit 0

Legend:

R = Readable bit W = Writable bit U = Unimplemented bit, read as '0'
 -n = Value at POR '1' = Bit is set '0' = Bit is cleared x = Bit is unknown

- bit 15-5 **Unimplemented:** Read as '0'
- bit 4 **DMA0MD:** DMA0 Module Disable bit⁽¹⁾
 1 = DMA0 module is disabled
 0 = DMA0 module is enabled
- DMA1MD:** DMA1 Module Disable bit⁽¹⁾
 1 = DMA1 module is disabled
 0 = DMA1 module is enabled
- DMA2MD:** DMA2 Module Disable bit⁽¹⁾
 1 = DMA2 module is disabled
 0 = DMA2 module is enabled
- DMA3MD:** DMA3 Module Disable bit⁽¹⁾
 1 = DMA3 module is disabled
 0 = DMA3 module is enabled
- bit 3 **PTGMD:** PTG Module Disable bit
 1 = PTG module is disabled
 0 = PTG module is enabled
- bit 2-0 **Unimplemented:** Read as '0'

Note 1: This single bit enables and disables all four DMA channels.

11.0 I/O PORTS

Note 1: This data sheet summarizes the features of the dsPIC33EPXXXGM3XX/6XX/7XX family of devices. It is not intended to be a comprehensive reference source. To complement the information in this data sheet, refer to the “dsPIC33/PIC24 Family Reference Manual”, “I/O Ports” (DS70000598) which is available from the Microchip web site (www.microchip.com).

2: Some registers and associated bits described in this section may not be available on all devices. Refer to [Section 4.0 “Memory Organization”](#) in this data sheet for device-specific register and bit information.

Many of the device pins are shared among the peripherals and the Parallel I/O ports. All I/O input ports feature Schmitt Trigger inputs for improved noise immunity.

11.1 Parallel I/O (PIO) Ports

Generally, a Parallel I/O port that shares a pin with a peripheral is subservient to the peripheral. The peripheral’s output buffer data and control signals are provided to a pair of multiplexers. The multiplexers select whether the peripheral or the associated port has ownership of the output data and control signals of

the I/O pin. The logic also prevents “loop through”, in which a port’s digital output can drive the input of a peripheral that shares the same pin. [Figure 11-1](#) illustrates how ports are shared with other peripherals and the associated I/O pin to which they are connected.

When a peripheral is enabled and the peripheral is actively driving an associated pin, the use of the pin as a general purpose output pin is disabled. The I/O pin can be read, but the output driver for the parallel port bit is disabled. If a peripheral is enabled, but the peripheral is not actively driving a pin, that pin can be driven by a port.

All port pins have eight registers directly associated with their operation as digital I/O. The Data Direction register (TRISx) determines whether the pin is an input or an output. If the Data Direction register bit is a ‘1’, then the pin is an input. All port pins are defined as inputs after a Reset. Reads from the latch (LATx) read the latch. Writes to the latch write the latch. Reads from the port (PORTx) read the port pins, while writes to the port pins write the latch.

Any bit and its associated data and control registers that are not valid for a particular device are disabled. This means the corresponding LATx and TRISx registers, and the port pin are read as zeros.

When a pin is shared with another peripheral or function that is defined as an input only, it is nevertheless regarded as a dedicated port because there is no other competing source of outputs.

FIGURE 11-1: BLOCK DIAGRAM OF A TYPICAL SHARED PORT STRUCTURE

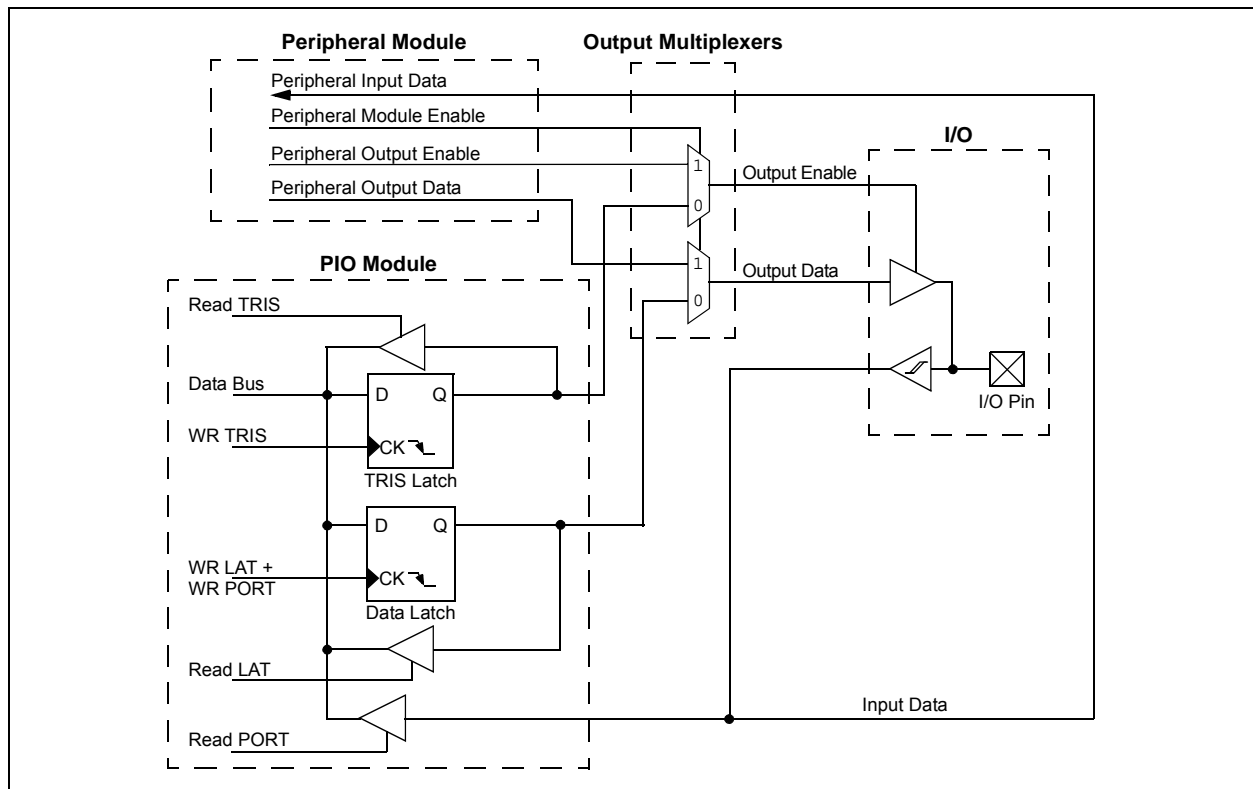

11.1.1 OPEN-DRAIN CONFIGURATION

In addition to the PORTx, LATx and TRISx registers for data control, port pins can also be individually configured for either digital or open-drain output. This is controlled by the Open-Drain Control x register, ODCx, associated with each port. Setting any of the bits configures the corresponding pin to act as an open-drain output.

The open-drain feature allows the generation of outputs other than VDD by using external pull-up resistors. The maximum open-drain voltage allowed on any pin is the same as the maximum VIH specification for that particular pin.

See the “Pin Diagrams” section for the available 5V tolerant pins and Table 33-10 for the maximum VIH specification for each pin.

11.2 Configuring Analog and Digital Port Pins

The ANSELx registers control the operation of the analog port pins. The port pins that are to function as analog inputs or outputs must have their corresponding ANSELx and TRISx bits set. In order to use port pins for I/O functionality with digital modules, such as timers, UARTs, etc., the corresponding ANSELx bit must be cleared.

The ANSELx register has a default value of 0xFFFF; therefore, all pins that share analog functions are analog (not digital) by default.

Pins with analog functions affected by the ANSELx registers are listed with a buffer type of analog in the Pinout I/O Descriptions (see Table 1-1 in Section 1.0 “Device Overview”).

If the TRISx bit is cleared (output) while the ANSELx bit is set, the digital output level (VOH or VOL) is converted by an analog peripheral, such as the ADCx module or comparator module.

When the PORTx register is read, all pins configured as analog input channels are read as cleared (a low level).

Pins configured as digital inputs do not convert an analog input. Analog levels on any pin defined as a digital input (including the ANx pins) can cause the input buffer to consume current that exceeds the device specifications.

11.2.1 I/O PORT WRITE/READ TIMING

One instruction cycle is required between a port direction change or port write operation and a read operation of the same port. Typically this instruction would be a NOP, as shown in Example 11-1.

11.3 Input Change Notification (ICN)

The Input Change Notification function of the I/O ports allows devices to generate interrupt requests to the processor in response to a Change-of-State (COS) on selected input pins. This feature can detect input Change-of-States (COS), even in Sleep mode when the clocks are disabled. Every I/O port pin can be selected (enabled) for generating an interrupt request on a Change-of-State.

Three control registers are associated with the ICN functionality of each I/O port. The CNENx registers contain the ICN interrupt enable control bits for each of the input pins. Setting any of these bits enables an ICN interrupt for the corresponding pins.

Each I/O pin also has a weak pull-up and a weak pull-down connected to it. The pull-ups and pull-downs act as a current source or sink source connected to the pin, and eliminate the need for external resistors when pushbutton or keypad devices are connected. The pull-ups and pull-downs are enabled separately using the CNPUx and the CNPDx registers, which contain the control bits for each of the pins. Setting any of the control bits enables the weak pull-ups and/or pull-downs for the corresponding pins.

Note: Pull-ups and pull-downs on Input Change Notification pins should always be disabled when the port pin is configured as a digital output.

EXAMPLE 11-1: PORTB WRITE/READ EXAMPLE

```
MOV    0xFF00, W0    ; Configure PORTB<15:8>
                        ; as inputs
MOV    W0, TRISB     ; and PORTB<7:0>
                        ; as outputs
NOP                                ; Delay 1 cycle
BTSS   PORTB, #13    ; Next Instruction
```

11.4 Peripheral Pin Select (PPS)

A major challenge in general purpose devices is providing the largest possible set of peripheral features while minimizing the conflict of features on I/O pins. The challenge is even greater on low pin count devices. In an application where more than one peripheral needs to be assigned to a single pin, inconvenient work arounds in application code or a complete redesign may be the only option.

Peripheral Pin Select configuration provides an alternative to these choices by enabling peripheral set selection and their placement on a wide range of I/O pins. By increasing the pinout options available on a particular device, users can better tailor the device to their entire application, rather than trimming the application to fit the device.

The Peripheral Pin Select configuration feature operates over a fixed subset of digital I/O pins. Users may independently map the input and/or output of most digital peripherals to any one of these I/O pins. Hardware safeguards are included that prevent accidental or spurious changes to the peripheral mapping once it has been established.

11.4.1 AVAILABLE PINS

The number of available pins is dependent on the particular device and its pin count. Pins that support the Peripheral Pin Select feature include the designation, “RPn” or “RPIn”, in their full pin designation, where “n” is the remappable pin number. “RP” is used to designate pins that support both remappable input and output functions, while “RPI” indicates pins that support remappable input functions only.

11.4.2 AVAILABLE PERIPHERALS

The peripherals managed by the Peripheral Pin Select are all digital only peripherals. These include general serial communications (UART and SPI), general purpose timer clock inputs, timer-related peripherals (input capture and output compare) and interrupt-on-change inputs.

In comparison, some digital only peripheral modules are never included in the Peripheral Pin Select feature. This is because the peripheral’s function requires special I/O circuitry on a specific port and cannot be easily connected to multiple pins. These modules include I²C™ and the PWM. A similar requirement excludes all modules with analog inputs, such as the A/D Converter.

A key difference between remappable and non-remappable peripherals is that remappable peripherals are not associated with a default I/O pin. The peripheral must always be assigned to a specific I/O pin before it can be used. In contrast, non-remappable peripherals are always available on a default pin, assuming that the peripheral is active and not conflicting with another peripheral.

When a remappable peripheral is active on a given I/O pin, it takes priority over all other digital I/O and digital communication peripherals associated with the pin. Priority is given regardless of the type of peripheral that is mapped. Remappable peripherals never take priority over any analog functions associated with the pin.

11.4.3 CONTROLLING PERIPHERAL PIN SELECT

Peripheral Pin Select features are controlled through two sets of SFRs: one to map peripheral inputs and one to map outputs. Because they are separately controlled, a particular peripheral’s input and output (if the peripheral has both) can be placed on any selectable function pin without constraint.

The association of a peripheral to a peripheral-selectable pin is handled in two different ways, depending on whether an input or output is being mapped.

dsPIC33EPXXXGM3XX/6XX/7XX

11.4.4 INPUT MAPPING

The inputs of the Peripheral Pin Select options are mapped on the basis of the peripheral. That is, a control register associated with a peripheral dictates the pin it will be mapped to. The RPINR_x registers are used to configure peripheral input mapping (see Register 11-1 through Register 11-29). Each register contains sets of 7-bit fields, with each set associated with one of the remappable peripherals. Programming a given peripheral's bit field with an appropriate 7-bit value maps the RP_n pin with the corresponding value to that peripheral. For any given device, the valid range of values for any bit field corresponds to the maximum number of Peripheral Pin Selections supported by the device.

For example, Figure 11-2 illustrates remappable pin selection for the U1RX input.

FIGURE 11-2: REMAPPABLE INPUT FOR U1RX

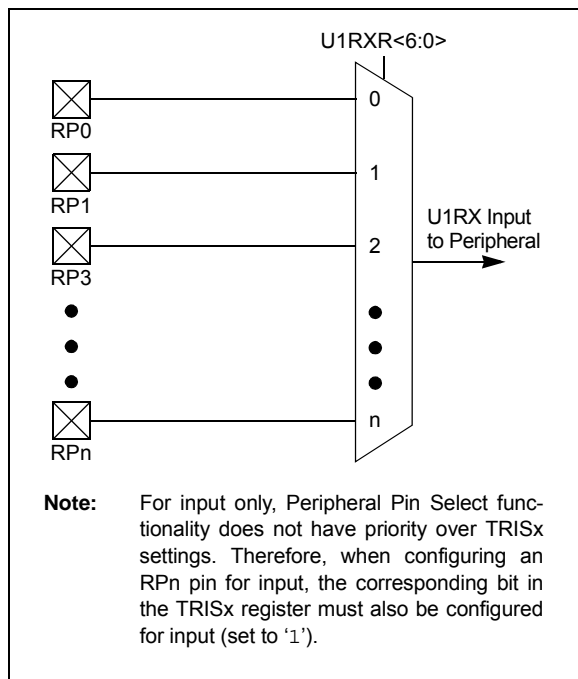

11.4.4.1 Virtual Connections

dsPIC33EPXXXGM3XX/6XX/7XX devices support virtual (internal) connections to the output of the op amp/comparator module (see Figure 26-1 in Section 26.0 “Op Amp/Comparator Module”) and the PTG module (see Section 25.0 “Peripheral Trigger Generator (PTG) Module”).

In addition, dsPIC33EPXXXGM3XX/6XX/7XX devices support virtual connections to the filtered QE_{Ix} module inputs: FINDX1, FHOME1, FINDX2 and FHOME2 (see Figure 17-1 in Section 17.0 “Quadrature Encoder Interface (QEI) Module”).

Virtual connections provide a simple way of inter-peripheral connection without utilizing a physical pin. For example, by setting the FLT1R<6:0> bits of the RPINR12 register to the value of `\b0000001`, the output of the analog comparator, C1OUT, will be connected to the PWM Fault 1 input, which allows the analog comparator to trigger PWM Faults without the use of an actual physical pin on the device.

Virtual connection to the QE_{Ix} module allows peripherals to be connected to the QE_{Ix} digital filter input. To utilize this filter, the QE_{Ix} module must be enabled and its inputs must be connected to a physical RP_n pin. Example 11-2 illustrates how the input capture module can be connected to the QE_{Ix} digital filter.

EXAMPLE 11-2: CONNECTING IC1 TO THE HOME1 QE1 DIGITAL FILTER INPUT ON PIN 43

```
RPINR15 = 0x2500;    /* Connect the QE1 HOME1 input to RP37 (pin 43) */
RPINR7  = 0x009;    /* Connect the IC1 input to the digital filter on the FHOME1 input */

QE1IOC = 0x4000;    /* Enable the QE1 digital filter */
QE1CON = 0x8000;    /* Enable the QE1 module */
```

TABLE 11-1: SELECTABLE INPUT SOURCES (MAPS INPUT TO FUNCTION)

Input Name ⁽¹⁾	Function Name	Register	Configuration Bits
External Interrupt 1	INT1	RPINR0	INT1R<6:0>
External Interrupt 2	INT2	RPINR1	INT2R<6:0>
Timer2 External Clock	T2CK	RPINR3	T2CKR<6:0>
Input Capture 1	IC1	RPINR7	IC1R<6:0>
Input Capture 2	IC2	RPINR7	IC2R<6:0>
Input Capture 3	IC3	RPINR8	IC3R<6:0>
Input Capture 4	IC4	RPINR8	IC4R<6:0>
Input Capture 5	IC5	RPINR9	IC5R<6:0>
Input Capture 6	IC6	RPINR9	IC6R<6:0>
Input Capture 7	IC7	RPINR10	IC7R<6:0>
Input Capture 8	IC8	RPINR10	IC8R<6:0>
Output Compare Fault A	OCFA	RPINR11	OCFAR<6:0>
PWM Fault 1	FLT1	RPINR12	FLT1R<6:0>
PWM Fault 2	FLT2	RPINR12	FLT2R<6:0>
QE1 Phase A	QEA1	RPINR14	QEA1R<6:0>
QE1 Phase B	QEB1	RPINR14	QEB1R<6:0>
QE1 Index	INDX1	RPINR 15	INDX1R<6:0>
QE1 Home	HOME1	RPINR15	HOM1R<6:0>
QE2 Phase A	QEA2	RPINR16	QEA2R<6:0>
QE2 Phase B	QEB2	RPINR16	QEB2R<6:0>
QE2 Index	INDX2	RPINR17	INDX2R<6:0>
QE2 Home	HOME2	RPINR17	HOM2R<6:0>
UART1 Receive	U1RX	RPINR18	U1RXR<6:0>
UART2 Receive	U2RX	RPINR19	U2RXR<6:0>
SPI2 Data Input	SDI2	RPINR22	SDI2R<6:0>
SPI2 Clock Input	SCK2	RPINR22	SCK2R<6:0>
SPI2 Slave Select	$\overline{SS2}$	RPINR23	SS2R<6:0>
DCI Data Input	CSDI	RPINR24	CSDIR>6:0>
DCI Clock Input	CCK	RPINR24	CCKR<6:0>
DCI Frame Synchronization Input	COFS	RPINR25	COFSR<6:0>
CAN1 Receive ⁽²⁾	C1RX	RPINR26	C1RXR<6:0>
CAN2 Receive ⁽²⁾	C2RX	RPINR26	C2RXR<6:0>
UART3 Receive	U3RX	RPINR27	U3RXR<6:0>
UART3 Clear-to-Send	$\overline{U3CTS}$	RPINR27	U3CTSR<6:0>
UART4 Receive	U4RX	RPINR28	U4RXR<6:0>
UART4 Clear-to-Send	$\overline{U4CTS}$	RPINR28	U4CTSR<6:0>
SPI3 Data Input	SDI3	RPINR29	SDI3R<6:0>
SPI3 Clock Input	SCK3	RPINR29	SCK3R<6:0>
SPI3 Slave Select	$\overline{SS3}$	RPINR 30	SS3R<6:0>

Note 1: Unless otherwise noted, all inputs use the Schmitt Trigger input buffers.

2: This input is available on dsPIC33EPXXXGM6XX/7XX devices only.

dsPIC33EPXXXGM3XX/6XX/7XX

TABLE 11-1: SELECTABLE INPUT SOURCES (MAPS INPUT TO FUNCTION) (CONTINUED)

Input Name ⁽¹⁾	Function Name	Register	Configuration Bits
PWM Sync Input 1	SYNCI1	RPINR37	SYNCI1R<6:0>
PWM Dead-Time Compensation 1	DTCMP1	RPINR38	DTCMP1R<6:0>
PWM Dead-Time Compensation 2	DTCMP2	RPINR39	DTCMP2R<6:0>
PWM Dead-Time Compensation 3	DTCMP3	RPINR39	DTCMP3R<6:0>
PWM Dead-Time Compensation 4	DTCMP4	RPINR40	DTCMP4R<6:0>
PWM Dead-Time Compensation 5	DTCMP5	RPINR40	DTCMP5R<6:0>
PWM Dead-Time Compensation 6	DTCMP6	RPINR41	DTCMP6R<6:0>

Note 1: Unless otherwise noted, all inputs use the Schmitt Trigger input buffers.

2: This input is available on dsPIC33EPXXXGM6XX/7XX devices only.

TABLE 11-2: INPUT PIN SELECTION FOR SELECTABLE INPUT SOURCES

Peripheral Pin Select Input Register Value	Input/Output	Pin Assignment	Peripheral Pin Select Input Register Value	Input/Output	Pin Assignment
000 0000	I	Vss	010 1100	I	RPI44
000 0001	I	CMP1 ⁽¹⁾	010 1101	I	RPI45
000 0010	I	CMP2 ⁽¹⁾	010 1110	I	RPI46
000 0011	I	CMP3 ⁽¹⁾	010 1111	I	RPI47
000 0100	I	CMP4 ⁽¹⁾	011 0000	I/O	RP48
000 0101	—	—	011 0001	I/O	RP49
000 0110	I	PTGO30 ⁽¹⁾	011 0010	I	RPI50
000 0111	I	PTGO31 ⁽¹⁾	011 0011	I	RPI51
000 1000	I	INDX1 ⁽¹⁾	011 0100	I	RPI52
000 1001	I	HOME1 ⁽¹⁾	011 0101	I	RPI53
000 1010	I	INDX2 ⁽¹⁾	011 0110	I/O	RP54
000 1011	I	HOME2 ⁽¹⁾	011 0111	I/O	RP55
000 1100	I	CMP5 ⁽¹⁾	011 1000	I/O	RP56
000 1101	—	—	011 1001	I/O	RP57
000 1110	—	—	011 1010	I	RPI58
000 1111	—	—	011 1011	—	—
001 0000	I	RPI16	011 1100	I	RPI60
001 0001	I	RPI17	011 1101	I	RPI61
001 0010	I	RPI18	011 1110	—	—
001 0011	I	RPI19	011 1111	I	RPI 63
001 0100	I/O	RP20	100 0000	—	—
001 0101	—	—	100 0001	—	—
001 0110	—	—	100 0010	—	—
001 0111	—	—	100 0011	—	—
001 1000	I	RPI24	100 0100	—	—
001 1001	I	RPI25	100 0101	I/O	RP69
001 1010	—	—	100 0110	I/O	RP70
001 1011	I	RPI27	100 0111	—	—
001 1100	I	RPI28	100 1000	I	RPI72
001 1101	—	—	100 1001	—	—
001 1110	—	—	100 1010	—	—
001 1111	—	—	100 1011	—	—
010 0000	I	RPI32	100 1100	I	RPI76
010 0001	I	RPI33	100 1101	I	RPI77
010 0010	I	RPI34	100 1110	—	—
010 0011	I/O	RP35	100 1111	—	—
010 0100	I/O	RP36	101 0000	I	RPI80
010 0101	I/O	RP37	101 0001	I/O	RP81
010 0110	I/O	RP38	101 0010	—	—
010 0111	I/O	RP39	101 0011	—	—
010 1000	I/O	RP40	101 0100	—	—

Legend: Shaded rows indicate PPS Input register values that are unimplemented.

Note 1: See [Section 11.4.4.1 “Virtual Connections”](#) for more information on selecting this pin assignment.

dsPIC33EPXXXGM3XX/6XX/7XX

TABLE 11-2: INPUT PIN SELECTION FOR SELECTABLE INPUT SOURCES (CONTINUED)

Peripheral Pin Select Input Register Value	Input/Output	Pin Assignment	Peripheral Pin Select Input Register Value	Input/Output	Pin Assignment
010 1001	I/O	RP41	101 0101	—	—
010 1010	I/O	RP42	101 0110	—	—
010 1011	I/O	RP43	101 0111	—	—
101 1000	—	—	110 1100	—	—
101 1001	—	—	110 1101	—	—
101 1010	—	—	110 1110	—	—
101 1011	—	—	110 1111	—	—
101 1100	—	—	111 0000	I	RPI112
101 1101	—	—	111 0001	I/O	RP113
101 1110	I	RPI94	111 0010	—	—
101 1111	I	RPI95	111 0011	—	—
110 0000	I	RPI96	111 0100	—	—
110 0001	I/O	RP97	111 0101	—	—
110 0010	—	—	111 0110	I/O	RP118
110 0011	—	—	111 0111	I	RPI119
110 0100	—	—	111 1000	I/O	RP120
110 0101	—	—	111 1001	I	RPI121
110 0110	—	—	111 1010	—	—
110 0111	—	—	111 1011	—	—
110 1000	—	—	111 1100	I	RPI124
110 1001	—	—	111 1101	I/O	RP125
110 1010	—	—	111 1110	I/O	RP126
110 1011	—	—	111 1111	I/O	RP127

Legend: Shaded rows indicate PPS Input register values that are unimplemented.

Note 1: See [Section 11.4.4.1 “Virtual Connections”](#) for more information on selecting this pin assignment.

11.4.5 OUTPUT MAPPING

In contrast to inputs, the outputs of the Peripheral Pin Select options are mapped on the basis of the pin. In this case, a control register associated with a particular pin dictates the peripheral output to be mapped. The RPORx registers are used to control output mapping. Like the RPINRx registers, each register contains sets of 6-bit fields, with each set associated with one RPn pin (see [Register 11-30](#) through [Register 11-42](#)). The value of the bit field corresponds to one of the peripherals and that peripheral's output is mapped to the pin (see [Table 11-3](#) and [Figure 11-3](#)).

A null output is associated with the output register Reset value of '0'. This is done to ensure that remappable outputs remain disconnected from all output pins by default.

FIGURE 11-3: MULTIPLEXING REMAPPABLE OUTPUT FOR RPn

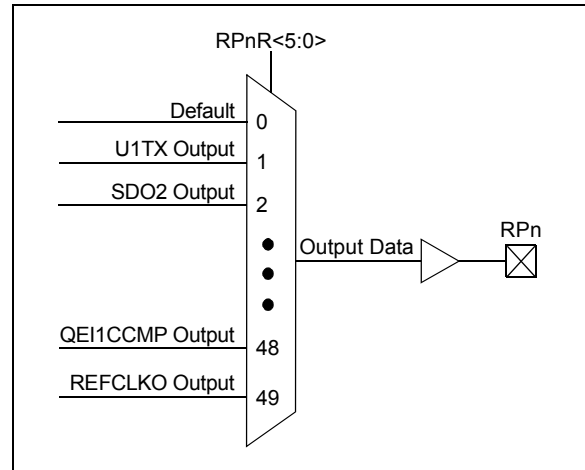

11.4.5.1 Mapping Limitations

The control schema of the peripheral select pins is not limited to a small range of fixed peripheral configurations. There are no mutual or hardware-enforced lockouts between any of the peripheral mapping SFRs. Literally any combination of peripheral mappings across any or all of the RPn pins is possible. This includes both many-to-one and one-to-many mappings of peripheral inputs and outputs to pins. While such mappings may be technically possible from a configuration point of view, they may not be supportable from an electrical point of view.

dsPIC33EPXXXGM3XX/6XX/7XX

TABLE 11-3: OUTPUT SELECTION FOR REMAPPABLE PINS (RPn)

Function	RPnR<5:0>	Output Name
Default Port	000000	RPn tied to Default Pin
U1TX	000001	RPn tied to UART1 Transmit
U2TX	000011	RPn tied to UART2 Transmit
SDO2	001000	RPn tied to SPI2 Data Output
SCK2	001001	RPn tied to SPI2 Clock Output
$\overline{SS2}$	001010	RPn tied to SPI2 Slave Select
CSDO	001011	RPn tied to DCI Data Output
CCLK	001100	RPn tied to DCI Clock Output
COFS	001101	RPn tied to DCI Frame Sync
C1TX	001110	RPn tied to CAN1 Transmit
C2TX	001111	RPn tied to CAN2 Transmit
OC1	010000	RPn tied to Output Compare 1 Output
OC2	010001	RPn tied to Output Compare 2 Output
OC3	010010	RPn tied to Output Compare 3 Output
OC4	010011	RPn tied to Output Compare 4 Output
OC5	010100	RPn tied to Output Compare 5 Output
OC6	010101	RPn tied to Output Compare 6 Output
OC7	010110	RPn tied to Output Compare 7 Output
OC8	010111	RPn tied to Output Compare 8 Output
C1OUT	011000	RPn tied to Comparator Output 1
C2OUT	011001	RPn tied to Comparator Output 2
C3OUT	011010	RPn tied to Comparator Output 3
U3TX	011011	RPn tied to UART3 Transmit
$\overline{U3RTS}$	011100	RPn tied to UART3 Ready-to-Send
U4TX	011101	RPn tied to UART4 Transmit
$\overline{U4RTS}$	011110	RPn tied to UART4 Ready-to-Send
SDO3	011111	RPn tied to SPI3 Slave Output
SCK3	100000	RPn tied to SPI3 Clock Output
$\overline{SS3}$	100001	RPn tied to SPI3 Slave Select
SYNCO1	101101	RPn tied to PWM Primary Time Base Sync Output
SYNCO2	101110	RPn tied to PWM Secondary Time Base Sync Output
QE1CCMP	101111	RPn tied to QE1 Counter Comparator Output
QE2CCMP	110000	RPn tied to QE2 Counter Comparator Output
REFCLKO	110001	RPn tied to Reference Clock Output
C4OUT	110010	RPn tied to Comparator Output 4
C5OUT	110011	RPn tied to Comparator Output 5

11.5 High-Voltage Detect

The dsPIC33EPXXXGM3XX/6XX/7XX devices contain High-Voltage Detection (HVD) which monitors the VCAP voltage. The HVD is used to monitor the VCAP supply voltage to ensure that an external connection does not raise the value above a safe level (~2.4V). If high core voltage is detected, all I/Os are disabled and put in a tri-state condition. The device remains in this I/O tri-state condition as long as the high-voltage condition is present.

11.6 I/O Helpful Tips

1. In some cases, certain pins, as defined in [Table 33-10](#) under “Injection Current”, have internal protection diodes to VDD and VSS. The term, “Injection Current”, is also referred to as “Clamp Current”. On designated pins with sufficient external current-limiting precautions by the user, I/O pin input voltages are allowed to be greater or less than the data sheet absolute maximum ratings, with respect to the VSS and VDD supplies. Note that when the user application forward biases either of the high or low side internal input clamp diodes, that the resulting current being injected into the device that is clamped internally by the VDD and VSS power rails, may affect the ADC accuracy by four to six counts.
2. I/O pins that are shared with any analog input pin (i.e., ANx) are always analog pins by default after any Reset. Consequently, configuring a pin as an analog input pin automatically disables the digital input pin buffer and any attempt to read the digital input level by reading PORTx or LATx will always return a ‘0’, regardless of the digital logic level on the pin. To use a pin as a digital I/O pin on a shared ANx pin, the user application needs to configure the Analog Pin Configuration registers in the I/O ports module (i.e., ANSELx) by setting the appropriate bit that corresponds to that I/O port pin to a ‘0’.

Note: Although it is not possible to use a digital input pin when its analog function is enabled, it is possible to use the digital I/O output function, TRISx = 0x0, while the analog function is also enabled. However, this is not recommended, particularly if the analog input is connected to an external analog voltage source, which would create signal contention between the analog signal and the output pin driver.

3. Most I/O pins have multiple functions. Referring to the device pin diagrams in this data sheet, the priorities of the functions allocated to any pins are indicated by reading the pin name from left-to-right. The left most function name takes precedence over any function to its right in the naming convention. For example: AN16/T2CK/T7CK/RC1. This indicates that AN16 is the highest priority in this example and will supersede all other functions to its right in the list. Those other functions to its right, even if enabled, would not work as long as any other function to its left was enabled. This rule applies to all of the functions listed for a given pin.
4. Each pin has an internal weak pull-up resistor and pull-down resistor that can be configured using the CNPUs and CNPDx registers, respectively. These resistors eliminate the need for external resistors in certain applications. The internal pull-up is up to $\sim(V_{DD} - 0.8)$, not VDD. This value is still above the minimum V_{IH} of CMOS and TTL devices.
5. When driving LEDs directly, the I/O pin can source or sink more current than what is specified in the V_{OH}/I_{OH} and V_{OL}/I_{OL} DC characteristic specifications. The respective I_{OH} and I_{OL} current rating only applies to maintaining the corresponding output at or above the V_{OH} and at or below the V_{OL} levels. However, for LEDs, unlike digital inputs of an externally connected device, they are not governed by the same minimum V_{IH}/V_{IL} levels. An I/O pin output can safely sink or source any current less than that listed in the absolute maximum rating section of this data sheet. For example:

$$V_{OH} = 2.4V @ I_{OH} = -8 \text{ mA and } V_{DD} = 3.3V$$

The maximum output current sourced by any 8 mA I/O pin = 12 mA.

LED source current < 12 mA is technically permitted. Refer to the V_{OH}/I_{OH} graphs in [Section 33.0 “Electrical Characteristics”](#) for additional information.

6. The Peripheral Pin Select (PPS) pin mapping rules are as follows:
- a) Only one “output” function can be active on a given pin at any time, regardless if it is a dedicated or remappable function (one pin, one output).
 - b) It is possible to assign a “remappable output” function to multiple pins and externally short or tie them together for increased current drive.
 - c) If any “dedicated output” function is enabled on a pin, it will take precedence over any remappable “output” function.
 - d) If any “dedicated digital” (input or output) function is enabled on a pin, any number of “input” remappable functions can be mapped to the same pin.
 - e) If any “dedicated analog” function(s) are enabled on a given pin, “digital input(s)” of any kind will all be disabled, although a single “digital output”, at the user’s cautionary discretion, can be enabled and active as long as there is no signal contention with an external analog input signal. For example, it is possible for the ADCx to convert the digital output logic level or to toggle a digital output on a comparator or ADCx input provided there is no external analog input, such as for a built-in self-test.
 - f) Any number of “input” remappable functions can be mapped to the same pin(s) at the same time, including to any pin with a single output from either a dedicated or remappable “output”.
 - g) The TRIS registers control *only* the digital I/O output buffer. Any other dedicated or remappable active “output” will automatically override the TRIS setting. The TRIS register *does not* control the digital logic “input” buffer. Remappable digital “inputs” do not automatically override TRIS settings, which means that the TRIS bit must be set to input for pins with only remappable input function(s) assigned.
 - h) All analog pins are enabled by default after any Reset and the corresponding digital input buffer on the pin is disabled. Only the Analog Pin Select registers control the digital input buffer, *not* the TRIS register. The user must disable the analog function on a pin using the Analog Pin Select registers in order to use any “digital input(s)” on a corresponding pin, no exceptions.

11.7 Peripheral Pin Select Registers

REGISTER 11-1: RPINR0: PERIPHERAL PIN SELECT INPUT REGISTER 0

U-0	R/W-0	R/W-0	R/W-0	R/W-0	R/W-0	R/W-0	R/W-0	
—	INT1R<6:0>							
bit 15								bit 8

U-0	U-0	U-0	U-0	U-0	U-0	U-0	U-0
—	—	—	—	—	—	—	—
bit 7							bit 0

Legend:			
R = Readable bit	W = Writable bit	U = Unimplemented bit, read as '0'	
-n = Value at POR	'1' = Bit is set	'0' = Bit is cleared	x = Bit is unknown

- bit 15 **Unimplemented:** Read as '0'
- bit 14-8 **INT1R<6:0>:** Assign External Interrupt 1 (INT1) to the Corresponding RPn Pin bits
 (see [Table 11-2](#) for input pin selection numbers)
 1111100 = Input tied to RPI124
 •
 •
 •
 0000001 = Input tied to CMP1
 0000000 = Input tied to Vss
- bit 7-0 **Unimplemented:** Read as '0'

dsPIC33EPXXXGM3XX/6XX/7XX

REGISTER 11-2: RPINR1: PERIPHERAL PIN SELECT INPUT REGISTER 1

U-0	U-0	U-0	U-0	U-0	U-0	U-0	U-0
—	—	—	—	—	—	—	—
bit 15							bit 8

U-0	R/W-0	R/W-0	R/W-0	R/W-0	R/W-0	R/W-0	R/W-0
—	INT2R<6:0>						
bit 7							bit 0

Legend:

R = Readable bit	W = Writable bit	U = Unimplemented bit, read as '0'
-n = Value at POR	'1' = Bit is set	'0' = Bit is cleared x = Bit is unknown

bit 15-7

Unimplemented: Read as '0'

bit 6-0

INT2R<6:0>: Assign External Interrupt 2 (INT2) to the Corresponding RPn Pin bits (see [Table 11-2](#) for input pin selection numbers)

1111100 = Input tied to RPI124

-
-
-

0000001 = Input tied to CMP1

0000000 = Input tied to Vss

REGISTER 11-3: RPINR3: PERIPHERAL PIN SELECT INPUT REGISTER 3

U-0	U-0	U-0	U-0	U-0	U-0	U-0	U-0
—	—	—	—	—	—	—	—
bit 15							bit 8

U-0	R/W-0	R/W-0	R/W-0	R/W-0	R/W-0	R/W-0	R/W-0
—	T2CKR<6:0>						
bit 7							bit 0

Legend:			
R = Readable bit	W = Writable bit	U = Unimplemented bit, read as '0'	
-n = Value at POR	'1' = Bit is set	'0' = Bit is cleared	x = Bit is unknown

- bit 15-7 **Unimplemented:** Read as '0'
- bit 6-0 **T2CKR<6:0>:** Assign Timer2 External Clock (T2CK) to the Corresponding RPn pin bits
 (see [Table 11-2](#) for input pin selection numbers)
 - 1111100 = Input tied to RPI124
 -
 -
 -
 - 0000001 = Input tied to CMP1
 - 0000000 = Input tied to Vss

dsPIC33EPXXXGM3XX/6XX/7XX

REGISTER 11-4: RPINR7: PERIPHERAL PIN SELECT INPUT REGISTER 7

U-0	R/W-0	R/W-0	R/W-0	R/W-0	R/W-0	R/W-0	R/W-0
—	IC2R<6:0>						
bit 15							bit 8

U-0	R/W-0	R/W-0	R/W-0	R/W-0	R/W-0	R/W-0	R/W-0
—	IC1R<6:0>						
bit 7							bit 0

Legend:

R = Readable bit W = Writable bit U = Unimplemented bit, read as '0'
 -n = Value at POR '1' = Bit is set '0' = Bit is cleared x = Bit is unknown

bit 15 **Unimplemented:** Read as '0'

bit 14-8 **IC2R<6:0>:** Assign Input Capture 2 (IC2) to the Corresponding RPn Pin bits (see [Table 11-2](#) for input pin selection numbers)

1111100 = Input tied to RPI124

•
•
•

0000001 = Input tied to CMP1

0000000 = Input tied to Vss

bit 7 **Unimplemented:** Read as '0'

bit 6-0 **IC1R<6:0>:** Assign Input Capture 1 (IC1) to the Corresponding RPn Pin bits (see [Table 11-2](#) for input pin selection numbers)

1111100 = Input tied to RPI124

•
•
•

0000001 = Input tied to CMP1

0000000 = Input tied to Vss

REGISTER 11-5: RPINR8: PERIPHERAL PIN SELECT INPUT REGISTER 8

U-0	R/W-0	R/W-0	R/W-0	R/W-0	R/W-0	R/W-0	R/W-0	
—	IC4R<6:0>							
bit 15								bit 8

U-0	R/W-0	R/W-0	R/W-0	R/W-0	R/W-0	R/W-0	R/W-0	
—	IC3R<6:0>							
bit 7								bit 0

Legend:			
R = Readable bit	W = Writable bit	U = Unimplemented bit, read as '0'	
-n = Value at POR	'1' = Bit is set	'0' = Bit is cleared	x = Bit is unknown

- bit 15 **Unimplemented:** Read as '0'
- bit 14-8 **IC4R<6:0>:** Assign Input Capture 4 (IC4) to the Corresponding RPn Pin bits
(see [Table 11-2](#) for input pin selection numbers)
 - 1111100 = Input tied to RPI124
 -
 -
 -
 - 0000001 = Input tied to CMP1
 - 0000000 = Input tied to Vss
- bit 7 **Unimplemented:** Read as '0'
- bit 6-0 **IC3R<6:0>:** Assign Input Capture 3 (IC3) to the Corresponding RPn Pin bits
(see [Table 11-2](#) for input pin selection numbers)
 - 1111100 = Input tied to RPI124
 -
 -
 -
 - 0000001 = Input tied to CMP1
 - 0000000 = Input tied to Vss

dsPIC33EPXXXGM3XX/6XX/7XX

REGISTER 11-6: RPINR9: PERIPHERAL PIN SELECT INPUT REGISTER 9

U-0	R/W-0	R/W-0	R/W-0	R/W-0	R/W-0	R/W-0	R/W-0
—	IC6R<6:0>						
bit 15							bit 8

U-0	R/W-0	R/W-0	R/W-0	R/W-0	R/W-0	R/W-0	R/W-0
—	IC5R<6:0>						
bit 7							bit 0

Legend:

R = Readable bit	W = Writable bit	U = Unimplemented bit, read as '0'
-n = Value at POR	'1' = Bit is set	'0' = Bit is cleared x = Bit is unknown

bit 15 **Unimplemented:** Read as '0'

bit 14-8 **IC6R<6:0>:** Assign Input Capture 6 (IC6) to the Corresponding RPn Pin bits
(see [Table 11-2](#) for input pin selection numbers)

1111100 = Input tied to RPI124

•
•
•

0000001 = Input tied to CMP1

0000000 = Input tied to Vss

bit 7 **Unimplemented:** Read as '0'

bit 6-0 **IC5R<6:0>:** Assign Input Capture 5 (IC5) to the Corresponding RPn Pin bits
(see [Table 11-2](#) for input pin selection numbers)

1111100 = Input tied to RPI124

•
•
•

0000001 = Input tied to CMP1

0000000 = Input tied to Vss

REGISTER 11-7: RPINR10: PERIPHERAL PIN SELECT INPUT REGISTER 10

U-0	R/W-0	R/W-0	R/W-0	R/W-0	R/W-0	R/W-0	R/W-0
—	IC8R<6:0>						
bit 15							bit 8

U-0	R/W-0	R/W-0	R/W-0	R/W-0	R/W-0	R/W-0	R/W-0
—	IC7R<6:0>						
bit 7							bit 0

Legend:			
R = Readable bit	W = Writable bit	U = Unimplemented bit, read as '0'	
-n = Value at POR	'1' = Bit is set	'0' = Bit is cleared	x = Bit is unknown

- bit 15 **Unimplemented:** Read as '0'
- bit 14-8 **IC8R<6:0>:** Assign Input Capture 8 (IC8) to the Corresponding RPn Pin bits
(see [Table 11-2](#) for input pin selection numbers)
 - 1111100 = Input tied to RPI124
 -
 -
 -
 - 0000001 = Input tied to CMP1
 - 0000000 = Input tied to Vss
- bit 7 **Unimplemented:** Read as '0'
- bit 6-0 **IC7R<6:0>:** Assign Input Capture 7 (IC7) to the Corresponding RPn Pin bits
(see [Table 11-2](#) for input pin selection numbers)
 - 1111100 = Input tied to RPI124
 -
 -
 -
 - 0000001 = Input tied to CMP1
 - 0000000 = Input tied to Vss

dsPIC33EPXXXGM3XX/6XX/7XX

REGISTER 11-8: RPINR11: PERIPHERAL PIN SELECT INPUT REGISTER 11

U-0	U-0	U-0	U-0	U-0	U-0	U-0	U-0
—	—	—	—	—	—	—	—
bit 15							bit 8

U-0	R/W-0	R/W-0	R/W-0	R/W-0	R/W-0	R/W-0	R/W-0
—	OCFAR<6:0>						
bit 7							bit 0

Legend:

R = Readable bit	W = Writable bit	U = Unimplemented bit, read as '0'
-n = Value at POR	'1' = Bit is set	'0' = Bit is cleared x = Bit is unknown

bit 15-7 **Unimplemented:** Read as '0'

bit 6-0 **OCFAR<6:0>:** Assign Output Compare Fault A (OCFA) to the Corresponding RPn Pin bits
 (see [Table 11-2](#) for input pin selection numbers)

1111100 = Input tied to RPI124

-
-
-

0000001 = Input tied to CMP1

0000000 = Input tied to Vss

REGISTER 11-9: RPINR12: PERIPHERAL PIN SELECT INPUT REGISTER 12

U-0	R/W-0	R/W-0	R/W-0	R/W-0	R/W-0	R/W-0	R/W-0
—	FLT2R<6:0>						
bit 15							bit 8

U-0	R/W-0	R/W-0	R/W-0	R/W-0	R/W-0	R/W-0	R/W-0
—	FLT1R<6:0>						
bit 7							bit 0

Legend:			
R = Readable bit	W = Writable bit	U = Unimplemented bit, read as '0'	
-n = Value at POR	'1' = Bit is set	'0' = Bit is cleared	x = Bit is unknown

- bit 15 **Unimplemented:** Read as '0'
- bit 14-8 **FLT2R<6:0>:** Assign PWM Fault 2 (FLT2) to the Corresponding RPn Pin bits
(see [Table 11-2](#) for input pin selection numbers)
- 1111100 = Input tied to RPI124
-
-
-
- 0000001 = Input tied to CMP1
- 0000000 = Input tied to Vss
- bit 7 **Unimplemented:** Read as '0'
- bit 6-0 **FLT1R<6:0>:** Assign PWM Fault 1 (FLT1) to the Corresponding RPn Pin bits
(see [Table 11-2](#) for input pin selection numbers)
- 1111100 = Input tied to RPI124
-
-
-
- 0000001 = Input tied to CMP1
- 0000000 = Input tied to Vss

dsPIC33EPXXXGM3XX/6XX/7XX

REGISTER 11-10: RPINR14: PERIPHERAL PIN SELECT INPUT REGISTER 14

U-0	R/W-0	R/W-0	R/W-0	R/W-0	R/W-0	R/W-0	R/W-0
—	QEB1R<6:0>						
bit 15							bit 8

U-0	R/W-0	R/W-0	R/W-0	R/W-0	R/W-0	R/W-0	R/W-0
—	QEA1R<6:0>						
bit 7							bit 0

Legend:

R = Readable bit	W = Writable bit	U = Unimplemented bit, read as '0'
-n = Value at POR	'1' = Bit is set	'0' = Bit is cleared x = Bit is unknown

bit 15 **Unimplemented:** Read as '0'

bit 14-8 **QEB1R<6:0>:** Assign QE11 Phase B (QEB1) to the Corresponding RPn Pin bits
(see Table 11-2 for input pin selection numbers)
 1111100 = Input tied to RPI124
 •
 •
 •
 0000001 = Input tied to CMP1
 0000000 = Input tied to Vss

bit 7 **Unimplemented:** Read as '0'

bit 6-0 **QEA1R<6:0>:** Assign QE11 Phase A (QEA1) to the Corresponding RPn Pin bits
(see Table 11-2 for input pin selection numbers)
 1111100 = Input tied to RPI124
 •
 •
 •
 0000001 = Input tied to CMP1
 0000000 = Input tied to Vss

REGISTER 11-11: RPINR15: PERIPHERAL PIN SELECT INPUT REGISTER 15

U-0	R/W-0	R/W-0	R/W-0	R/W-0	R/W-0	R/W-0	R/W-0
—	HOME1R<6:0>						
bit 15							bit 8

U-0	R/W-0	R/W-0	R/W-0	R/W-0	R/W-0	R/W-0	R/W-0
—	INDX1R<6:0>						
bit 7							bit 0

Legend:			
R = Readable bit	W = Writable bit	U = Unimplemented bit, read as '0'	
-n = Value at POR	'1' = Bit is set	'0' = Bit is cleared	x = Bit is unknown

- bit 15 **Unimplemented:** Read as '0'
- bit 14-8 **HOME1R<6:0>:** Assign QE11 HOME (HOME1) to the Corresponding RPn Pin bits
 (see [Table 11-2](#) for input pin selection numbers)
 1111100 = Input tied to RPI124
 •
 •
 •
 0000001 = Input tied to CMP1
 0000000 = Input tied to Vss
- bit 7 **Unimplemented:** Read as '0'
- bit 6-0 **IND1XR<6:0>:** Assign QE11 INDEX (INDX1) to the Corresponding RPn Pin bits
 (see [Table 11-2](#) for input pin selection numbers)
 1111100 = Input tied to RPI124
 •
 •
 •
 0000001 = Input tied to CMP1
 0000000 = Input tied to Vss

dsPIC33EPXXXGM3XX/6XX/7XX

REGISTER 11-12: RPINR16: PERIPHERAL PIN SELECT INPUT REGISTER 16

U-0	R/W-0	R/W-0	R/W-0	R/W-0	R/W-0	R/W-0	R/W-0
—	QEB2R<6:0>						
bit 15	bit 8						

U-0	R/W-0	R/W-0	R/W-0	R/W-0	R/W-0	R/W-0	R/W-0
—	QEA2R<6:0>						
bit 7	bit 0						

Legend:

R = Readable bit	W = Writable bit	U = Unimplemented bit, read as '0'
-n = Value at POR	'1' = Bit is set	'0' = Bit is cleared x = Bit is unknown

bit 15 **Unimplemented:** Read as '0'

bit 14-8 **QEB2R<6:0>:** Assign QEI2 Phase B (QEB2) to the Corresponding RPn/RPIn Pin bits
(see [Table 11-2](#) for input pin selection numbers)

1111111 = Input tied to RP127

•
•
•

0000001 = Input tied to CMP1

0000000 = Input tied to Vss

bit 7 **Unimplemented:** Read as '0'

bit 6-0 **QEA2R<6:0>:** Assign A QEI2 Phase A (QEA2) to the Corresponding RPn/RPIn Pin bits
(see [Table 11-2](#) for input pin selection numbers)

1111111 = Input tied to RP127

•
•
•

0000001 = Input tied to CMP1

0000000 = Input tied to Vss

REGISTER 11-13: RPINR17: PERIPHERAL PIN SELECT INPUT REGISTER 17

U-0	R/W-0	R/W-0	R/W-0	R/W-0	R/W-0	R/W-0	R/W-0
—	HOME2R<6:0>						
bit 15							bit 8

U-0	R/W-0	R/W-0	R/W-0	R/W-0	R/W-0	R/W-0	R/W-0
—	INDX2R<6:0>						
bit 7							bit 0

Legend:			
R = Readable bit	W = Writable bit	U = Unimplemented bit, read as '0'	
-n = Value at POR	'1' = Bit is set	'0' = Bit is cleared	x = Bit is unknown

- bit 15 **Unimplemented:** Read as '0'
- bit 14-8 **HOME2R<6:0>:** Assign QEI2 HOME (HOME2) to the Corresponding RPn Pin bits
(see [Table 11-2](#) for input pin selection numbers)
 - 1111100 = Input tied to RPI124
 -
 -
 -
 - 0000001 = Input tied to CMP1
 - 0000000 = Input tied to Vss
- bit 7 **Unimplemented:** Read as '0'
- bit 6-0 **IND2XR<6:0>:** Assign QEI2 INDEX (INDX2) to the Corresponding RPn Pin bits
(see [Table 11-2](#) for input pin selection numbers)
 - 1111100 = Input tied to RPI124
 -
 -
 -
 - 0000001 = Input tied to CMP1
 - 0000000 = Input tied to Vss

dsPIC33EPXXXGM3XX/6XX/7XX

REGISTER 11-14: RPINR18: PERIPHERAL PIN SELECT INPUT REGISTER 18

U-0	U-0	U-0	U-0	U-0	U-0	U-0	U-0
—	—	—	—	—	—	—	—
bit 15							bit 8

U-0	R/W-0	R/W-0	R/W-0	R/W-0	R/W-0	R/W-0	R/W-0
—	U1RXR<6:0>						
bit 7							bit 0

Legend:

R = Readable bit W = Writable bit U = Unimplemented bit, read as '0'
 -n = Value at POR '1' = Bit is set '0' = Bit is cleared x = Bit is unknown

bit 15-7 **Unimplemented:** Read as '0'
 bit 6-0 **U1RXR<6:0>:** Assign UART1 Receive (U1RX) to the Corresponding RPn Pin bits
 (see [Table 11-2](#) for input pin selection numbers)
 1111100 = Input tied to RPI124
 •
 •
 •
 0000001 = Input tied to CMP1
 0000000 = Input tied to Vss

REGISTER 11-15: RPINR19: PERIPHERAL PIN SELECT INPUT REGISTER 19

U-0	U-0	U-0	U-0	U-0	U-0	U-0	U-0
—	—	—	—	—	—	—	—
bit 15							bit 8

U-0	R/W-0	R/W-0	R/W-0	R/W-0	R/W-0	R/W-0	R/W-0
—	U2RXR<6:0>						
bit 7							bit 0

Legend:

R = Readable bit W = Writable bit U = Unimplemented bit, read as '0'
 -n = Value at POR '1' = Bit is set '0' = Bit is cleared x = Bit is unknown

bit 15-7 **Unimplemented:** Read as '0'
 bit 6-0 **U2RXR<6:0>:** Assign UART2 Receive (U2RX) to the Corresponding RPn Pin bits
 (see [Table 11-2](#) for input pin selection numbers)
 1111100 = Input tied to RPI124
 •
 •
 •
 0000001 = Input tied to CMP1
 0000000 = Input tied to Vss

REGISTER 11-16: RPINR22: PERIPHERAL PIN SELECT INPUT REGISTER 22

U-0	R/W-0	R/W-0	R/W-0	R/W-0	R/W-0	R/W-0	R/W-0
—	SCK2R<6:0>						
bit 15							bit 8

U-0	R/W-0	R/W-0	R/W-0	R/W-0	R/W-0	R/W-0	R/W-0
—	SDI2R<6:0>						
bit 7							bit 0

Legend:

R = Readable bit	W = Writable bit	U = Unimplemented bit, read as '0'
-n = Value at POR	'1' = Bit is set	'0' = Bit is cleared x = Bit is unknown

- bit 15 **Unimplemented:** Read as '0'
- bit 14-8 **SCK2R<6:0>:** Assign SPI2 Clock Input (SCK2) to the Corresponding RPN Pin bits
(see [Table 11-2](#) for input pin selection numbers)
 - 1111100 = Input tied to RPI124
 -
 -
 -
 - 0000001 = Input tied to CMP1
 - 0000000 = Input tied to Vss
- bit 7 **Unimplemented:** Read as '0'
- bit 6-0 **SDI2R<6:0>:** Assign SPI2 Data Input (SDI2) to the Corresponding RPN Pin bits
(see [Table 11-2](#) for input pin selection numbers)
 - 1111100 = Input tied to RPI124
 -
 -
 -
 - 0000001 = Input tied to CMP1
 - 0000000 = Input tied to Vss

dsPIC33EPXXXGM3XX/6XX/7XX

REGISTER 11-17: RPINR23: PERIPHERAL PIN SELECT INPUT REGISTER 23

U-0	U-0	U-0	U-0	U-0	U-0	U-0	U-0
—	—	—	—	—	—	—	—
bit 15						bit 8	

U-0	R/W-0	R/W-0	R/W-0	R/W-0	R/W-0	R/W-0	R/W-0
—	SS2R<6:0>						—
bit 7						bit 0	

Legend:

R = Readable bit	W = Writable bit	U = Unimplemented bit, read as '0'
-n = Value at POR	'1' = Bit is set	'0' = Bit is cleared
		x = Bit is unknown

bit 15-7

Unimplemented: Read as '0'

bit 6-0

SS2R<6:0>: Assign SPI2 Slave Select ($\overline{SS2}$) to the Corresponding RPn Pin bits (see [Table 11-2](#) for input pin selection numbers)

1111100 = Input tied to RPI124

-
-
-

0000001 = Input tied to CMP1

0000000 = Input tied to Vss

REGISTER 11-18: RPINR24: PERIPHERAL PIN SELECT INPUT REGISTER 24

U-0	R/W-0	R/W-0	R/W-0	R/W-0	R/W-0	R/W-0	R/W-0
—	C _{SCK2R} <6:0>						
bit 15							bit 8

U-0	R/W-0	R/W-0	R/W-0	R/W-0	R/W-0	R/W-0	R/W-0
—	C _{SDIR} <6:0>						
bit 7							bit 0

Legend:			
R = Readable bit	W = Writable bit	U = Unimplemented bit, read as '0'	
-n = Value at POR	'1' = Bit is set	'0' = Bit is cleared	x = Bit is unknown

- bit 15 **Unimplemented:** Read as '0'
- bit 14-8 **C_{SCK2R}<6:0>**: Assign DCI Clock Input (C_{SCK}) to the Corresponding RPn Pin bits
(see [Table 11-2](#) for input pin selection numbers)
 - 1111100 = Input tied to RPI124
 -
 -
 -
 - 0000001 = Input tied to CMP1
 - 0000000 = Input tied to V_{SS}
- bit 7 **Unimplemented:** Read as '0'
- bit 6-0 **C_{SDIR}<6:0>**: Assign DCI Data Input (C_{SDI}) to the Corresponding RPn Pin bits
(see [Table 11-2](#) for input pin selection numbers)
 - 1111100 = Input tied to RPI124
 -
 -
 -
 - 0000001 = Input tied to CMP1
 - 0000000 = Input tied to V_{SS}

dsPIC33EPXXXGM3XX/6XX/7XX

REGISTER 11-19: RPINR25: PERIPHERAL PIN SELECT INPUT REGISTER 25

U-0	U-0	U-0	U-0	U-0	U-0	U-0	U-0
—	—	—	—	—	—	—	—
bit 15						bit 8	

U-0	R/W-0	R/W-0	R/W-0	R/W-0	R/W-0	R/W-0	R/W-0
—	COFSR<6:0>						
bit 7						bit 0	

Legend:

R = Readable bit	W = Writable bit	U = Unimplemented bit, read as '0'
-n = Value at POR	'1' = Bit is set	'0' = Bit is cleared
		x = Bit is unknown

bit 15-7 **Unimplemented:** Read as '0'

bit 6-0 **COFSR<6:0>:** Assign DCI Frame Sync Input (COFS) to the Corresponding RPn Pin bits
 (see [Table 11-2](#) for input pin selection numbers)

1111100 = Input tied to RPI124

-
-
-

0000001 = Input tied to CMP1

0000000 = Input tied to Vss

REGISTER 11-20: RPINR26: PERIPHERAL PIN SELECT INPUT REGISTER 26⁽¹⁾

U-0	R/W-0	R/W-0	R/W-0	R/W-0	R/W-0	R/W-0	R/W-0
—	C2RXR<6:0>						
bit 15							bit 8

U-0	R/W-0	R/W-0	R/W-0	R/W-0	R/W-0	R/W-0	R/W-0
—	C1RXR<6:0>						
bit 7							bit 0

Legend:			
R = Readable bit	W = Writable bit	U = Unimplemented bit, read as '0'	
-n = Value at POR	'1' = Bit is set	'0' = Bit is cleared	x = Bit is unknown

- bit 15 **Unimplemented:** Read as '0'
- bit 14-8 **C2RXR<6:0>:** Assign CAN2 RX Input (C2RX) to the Corresponding RPn Pin bits
(see [Table 11-2](#) for input pin selection numbers)
 1111100 = Input tied to RPI124
 •
 •
 •
 0000001 = Input tied to CMP1
 0000000 = Input tied to Vss
- bit 7 **Unimplemented:** Read as '0'
- bit 6-0 **C1RXR<6:0>:** Assign CAN1 RX Input (C1RX) to the Corresponding RPn Pin bits
(see [Table 11-2](#) for input pin selection numbers)
 1111100 = Input tied to RPI124
 •
 •
 •
 0000001 = Input tied to CMP1
 0000000 = Input tied to Vss

Note 1: This register is not available on dsPIC33EPXXXGM3XX devices.

dsPIC33EPXXXGM3XX/6XX/7XX

REGISTER 11-21: RPINR27: PERIPHERAL PIN SELECT INPUT REGISTER 27

U-0	R/W-0	R/W-0	R/W-0	R/W-0	R/W-0	R/W-0	R/W-0
—	U3CTSR<6:0>						
bit 15							bit 8

U-0	R/W-0	R/W-0	R/W-0	R/W-0	R/W-0	R/W-0	R/W-0
—	U3RXR<6:0>						
bit 7							bit 0

Legend:

R = Readable bit	W = Writable bit	U = Unimplemented bit, read as '0'
-n = Value at POR	'1' = Bit is set	'0' = Bit is cleared x = Bit is unknown

bit 15 **Unimplemented:** Read as '0'

bit 14-8 **U3CTSR<6:0>:** Assign UART3 Clear-to-Send (U3CTS) to the Corresponding RPn/RPIn Pin bits (see [Table 11-2](#) for input pin selection numbers)

 1111111 = Input tied to RP124

 •

 •

 •

 0000001 = Input tied to CMP1

 0000000 = Input tied to Vss

bit 7 **Unimplemented:** Read as '0'

bit 6-0 **U3RXR<6:0>:** Assign UART3 Receive (U3RX) to the Corresponding RPn/RPIn Pin bits (see [Table 11-2](#) for input pin selection numbers)

 1111111 = Input tied to RP124

 •

 •

 •

 0000001 = Input tied to CMP1

 0000000 = Input tied to Vss

REGISTER 11-22: RPINR28: PERIPHERAL PIN SELECT INPUT REGISTER 28

U-0	R/W-0	R/W-0	R/W-0	R/W-0	R/W-0	R/W-0	R/W-0
—	U4CTSR<6:0>						
bit 15							bit 8

U-0	R/W-0	R/W-0	R/W-0	R/W-0	R/W-0	R/W-0	R/W-0
—	U4RXR<6:0>						
bit 7							bit 0

Legend:

R = Readable bit	W = Writable bit	U = Unimplemented bit, read as '0'
-n = Value at POR	'1' = Bit is set	'0' = Bit is cleared x = Bit is unknown

- bit 15 **Unimplemented:** Read as '0'
- bit 14-8 **U4CTSR<6:0>:** Assign UART4 Clear-to-Send (U4CTS) to the Corresponding RPn/RPIn Pin bits (see [Table 11-2](#) for input pin selection numbers)
 - 1111111 = Input tied to RP124
 -
 -
 -
 - 0000001 = Input tied to CMP1
 - 0000000 = Input tied to Vss
- bit 7 **Unimplemented:** Read as '0'
- bit 6-0 **U4RXR<6:0>:** Assign UART4 Receive (U4RX) to the Corresponding RPn/RPIn Pin bits (see [Table 11-2](#) for input pin selection numbers)
 - 1111111 = Input tied to RP124
 -
 -
 -
 - 0000001 = Input tied to CMP1
 - 0000000 = Input tied to Vss

dsPIC33EPXXXGM3XX/6XX/7XX

REGISTER 11-23: RPINR29: PERIPHERAL PIN SELECT INPUT REGISTER 29

U-0	R/W-0	R/W-0	R/W-0	R/W-0	R/W-0	R/W-0	R/W-0
—	SCK3R<6:0>						
bit 15							bit 8

U-0	R/W-0	R/W-0	R/W-0	R/W-0	R/W-0	R/W-0	R/W-0
—	SDI3R<6:0>						
bit 7							bit 0

Legend:

R = Readable bit	W = Writable bit	U = Unimplemented bit, read as '0'
-n = Value at POR	'1' = Bit is set	'0' = Bit is cleared x = Bit is unknown

- bit 15 **Unimplemented:** Read as '0'
- bit 14-8 **SCK3R<6:0>:** Assign SPI3 Clock Input (SCK3) to the Corresponding RPn/RPIn Pin bits
(see [Table 11-2](#) for input pin selection numbers)
- 1111111 = Input tied to RP124
-
-
-
- 0000001 = Input tied to CMP1
- 0000000 = Input tied to Vss
- bit 7 **Unimplemented:** Read as '0'
- bit 6-0 **SDI3R<6:0>:** Assign SPI3 Data Input (SDI3) to the Corresponding RPn/RPIn Pin bits
(see [Table 11-2](#) for input pin selection numbers)
- 1111111 = Input tied to RP124
-
-
-
- 0000001 = Input tied to CMP1
- 0000000 = Input tied to Vss

REGISTER 11-24: RPINR30: PERIPHERAL PIN SELECT INPUT REGISTER 30

U-0	U-0	U-0	U-0	U-0	U-0	U-0	U-0
—	—	—	—	—	—	—	—
bit 15							bit 8

U-0	R/W-0	R/W-0	R/W-0	R/W-0	R/W-0	R/W-0	R/W-0
—	SS3R<6:0>						
bit 7							bit 0

Legend:

R = Readable bit	W = Writable bit	U = Unimplemented bit, read as '0'
-n = Value at POR	'1' = Bit is set	'0' = Bit is cleared x = Bit is unknown

bit 15-7 **Unimplemented:** Read as '0'

bit 6-0 **SS3R<6:0>:** Assign SPI3 Slave Select Input ($\overline{SS3}$) to the Corresponding RPn/RPIn Pin bits
 (see [Table 11-2](#) for input pin selection numbers)

1111111 = Input tied to RP124

-
-
-

0000001 = Input tied to CMP1

0000000 = Input tied to Vss

dsPIC33EPXXXGM3XX/6XX/7XX

REGISTER 11-25: RPINR37: PERIPHERAL PIN SELECT INPUT REGISTER 37

U-0	R/W-0	R/W-0	R/W-0	R/W-0	R/W-0	R/W-0	R/W-0
—	SYNC1R<6:0>						
bit 15							bit 8

U-0	U-0	U-0	U-0	U-0	U-0	U-0	U-0
—	—	—	—	—	—	—	—
bit 7							bit 0

Legend:

R = Readable bit	W = Writable bit	U = Unimplemented bit, read as '0'
-n = Value at POR	'1' = Bit is set	'0' = Bit is cleared x = Bit is unknown

bit 15 **Unimplemented:** Read as '0'

bit 14-8 **SYNC1R<6:0>:** Assign PWM Synchronization Input 1 to the Corresponding RPn Pin bits
(see [Table 11-2](#) for input pin selection numbers)

 1111100 = Input tied to RPI124

 •

 •

 •

 0000001 = Input tied to CMP1

 0000000 = Input tied to Vss

bit 7-0 **Unimplemented:** Read as '0'

dsPIC33EPXXXGM3XX/6XX/7XX

REGISTER 11-26: RPINR38: PERIPHERAL PIN SELECT INPUT REGISTER 38

U-0	R/W-0	R/W-0	R/W-0	R/W-0	R/W-0	R/W-0	R/W-0	
—	DTCMP1R<6:0>							
bit 15								bit 8

U-0	U-0	U-0	U-0	U-0	U-0	U-0	U-0
—	—	—	—	—	—	—	—
bit 7							bit 0

Legend:			
R = Readable bit	W = Writable bit	U = Unimplemented bit, read as '0'	
-n = Value at POR	'1' = Bit is set	'0' = Bit is cleared	x = Bit is unknown

- bit 15 **Unimplemented:** Read as '0'
- bit 14-8 **DTCMP1R<6:0>:** Assign PWM Dead-Time Compensation Input 1 to the Corresponding RPn Pin bits (see [Table 11-2](#) for input pin selection numbers)
 - 1111100 = Input tied to RPI124
 -
 -
 -
 - 0000001 = Input tied to CMP1
 - 0000000 = Input tied to Vss
- bit 7-0 **Unimplemented:** Read as '0'

dsPIC33EPXXXGM3XX/6XX/7XX

REGISTER 11-27: RPINR39: PERIPHERAL PIN SELECT INPUT REGISTER 39

U-0	R/W-0	R/W-0	R/W-0	R/W-0	R/W-0	R/W-0	R/W-0
—	DTCMP3R<6:0>						
bit 15	bit 8						

U-0	R/W-0	R/W-0	R/W-0	R/W-0	R/W-0	R/W-0	R/W-0
—	DTCMP2R<6:0>						
bit 7	bit 0						

Legend:

R = Readable bit	W = Writable bit	U = Unimplemented bit, read as '0'
-n = Value at POR	'1' = Bit is set	'0' = Bit is cleared x = Bit is unknown

- bit 15 **Unimplemented:** Read as '0'
- bit 14-8 **DTCMP3R<6:0>:** Assign PWM Dead-Time Compensation Input 3 to the Corresponding RPn Pin bits (see [Table 11-2](#) for input pin selection numbers)
 - 1111100 = Input tied to RPI124
 -
 -
 -
 - 0000001 = Input tied to CMP1
 - 0000000 = Input tied to Vss
- bit 7 **Unimplemented:** Read as '0'
- bit 6-0 **DTCMP2R<6:0>:** Assign PWM Dead-Time Compensation Input 2 to the Corresponding RPn Pin bits (see [Table 11-2](#) for input pin selection numbers)
 - 1111100 = Input tied to RPI124
 -
 -
 -
 - 0000001 = Input tied to CMP1
 - 0000000 = Input tied to Vss

REGISTER 11-28: RPINR40: PERIPHERAL PIN SELECT INPUT REGISTER 40

U-0	R/W-0	R/W-0	R/W-0	R/W-0	R/W-0	R/W-0	R/W-0	
—	DTCMP5R<6:0>							
bit 15								bit 8

U-0	R/W-0	R/W-0	R/W-0	R/W-0	R/W-0	R/W-0	R/W-0	
—	DTCMP4R<6:0>							
bit 7								bit 0

Legend:			
R = Readable bit	W = Writable bit	U = Unimplemented bit, read as '0'	
-n = Value at POR	'1' = Bit is set	'0' = Bit is cleared	x = Bit is unknown

- bit 15 **Unimplemented:** Read as '0'
- bit 14-8 **DTCMP5R<6:0>:** Assign PWM Dead-Time Compensation Input 5 to the Corresponding RPn Pin bits (see [Table 11-2](#) for input pin selection numbers)
 - 1111100 = Input tied to RPI124
 -
 -
 -
 - 0000001 = Input tied to CMP1
 - 0000000 = Input tied to Vss
- bit 7 **Unimplemented:** Read as '0'
- bit 6-0 **DTCMP4R<6:0>:** Assign PWM Dead-Time Compensation Input 4 to the Corresponding RPn Pin bits (see [Table 11-2](#) for input pin selection numbers)
 - 1111100 = Input tied to RPI124
 -
 -
 -
 - 0000001 = Input tied to CMP1
 - 0000000 = Input tied to Vss

dsPIC33EPXXXGM3XX/6XX/7XX

REGISTER 11-29: RPINR41: PERIPHERAL PIN SELECT INPUT REGISTER 41

U-0	U-0	U-0	U-0	U-0	U-0	U-0	U-0
—	—	—	—	—	—	—	—
bit 15							bit 8

U-0	R/W-0	R/W-0	R/W-0	R/W-0	R/W-0	R/W-0	R/W-0
—	DTCMP6R<6:0>						—
bit 7							bit 0

Legend:

R = Readable bit	W = Writable bit	U = Unimplemented bit, read as '0'
-n = Value at POR	'1' = Bit is set	'0' = Bit is cleared
		x = Bit is unknown

bit 15-7 **Unimplemented:** Read as '0'

bit 6-0 **DTCMP6R<6:0>:** Assign PWM Dead-Time Compensation Input 6 to the Corresponding RPn Pin bits (see [Table 11-2](#) for input pin selection numbers)

1111100 = Input tied to RPI124

-
-
-

0000001 = Input tied to CMP1

0000000 = Input tied to Vss

dsPIC33EPXXXGM3XX/6XX/7XX

REGISTER 11-30: RPOR0: PERIPHERAL PIN SELECT OUTPUT REGISTER 0

U-0	U-0	R/W-0	R/W-0	R/W-0	R/W-0	R/W-0	R/W-0
—	—	RP35R<5:0>					
bit 15							bit 8

U-0	U-0	R/W-0	R/W-0	R/W-0	R/W-0	R/W-0	R/W-0
—	—	RP20R<5:0>					
bit 7							bit 0

Legend:

R = Readable bit W = Writable bit U = Unimplemented bit, read as '0'
 -n = Value at POR '1' = Bit is set '0' = Bit is cleared x = Bit is unknown

- bit 15-14 **Unimplemented:** Read as '0'
- bit 13-8 **RP35R<5:0>:** Peripheral Output Function is Assigned to RP35 Output Pin bits
 (see [Table 11-3](#) for peripheral function numbers)
- bit 7-6 **Unimplemented:** Read as '0'
- bit 5-0 **RP20R<5:0>:** Peripheral Output Function is Assigned to RP20 Output Pin bits
 (see [Table 11-3](#) for peripheral function numbers)

REGISTER 11-31: RPOR1: PERIPHERAL PIN SELECT OUTPUT REGISTER 1

U-0	U-0	R/W-0	R/W-0	R/W-0	R/W-0	R/W-0	R/W-0
—	—	RP37R<5:0>					
bit 15							bit 8

U-0	U-0	R/W-0	R/W-0	R/W-0	R/W-0	R/W-0	R/W-0
—	—	RP36R<5:0>					
bit 7							bit 0

Legend:

R = Readable bit W = Writable bit U = Unimplemented bit, read as '0'
 -n = Value at POR '1' = Bit is set '0' = Bit is cleared x = Bit is unknown

- bit 15-14 **Unimplemented:** Read as '0'
- bit 13-8 **RP37R<5:0>:** Peripheral Output Function is Assigned to RP37 Output Pin bits
 (see [Table 11-3](#) for peripheral function numbers)
- bit 7-6 **Unimplemented:** Read as '0'
- bit 5-0 **RP36R<5:0>:** Peripheral Output Function is Assigned to RP36 Output Pin bits
 (see [Table 11-3](#) for peripheral function numbers)

dsPIC33EPXXXGM3XX/6XX/7XX

REGISTER 11-32: RPOR2: PERIPHERAL PIN SELECT OUTPUT REGISTER 2

U-0	U-0	R/W-0	R/W-0	R/W-0	R/W-0	R/W-0	R/W-0
—	—	RP39R<5:0>					
bit 15							bit 8

U-0	U-0	R/W-0	R/W-0	R/W-0	R/W-0	R/W-0	R/W-0
—	—	RP38R<5:0>					
bit 7							bit 0

Legend:

R = Readable bit W = Writable bit U = Unimplemented bit, read as '0'
 -n = Value at POR '1' = Bit is set '0' = Bit is cleared x = Bit is unknown

- bit 15-14 **Unimplemented:** Read as '0'
- bit 13-8 **RP39R<5:0>:** Peripheral Output Function is Assigned to RP39 Output Pin bits
 (see [Table 11-3](#) for peripheral function numbers)
- bit 7-6 **Unimplemented:** Read as '0'
- bit 5-0 **RP38R<5:0>:** Peripheral Output Function is Assigned to RP38 Output Pin bits
 (see [Table 11-3](#) for peripheral function numbers)

REGISTER 11-33: RPOR3: PERIPHERAL PIN SELECT OUTPUT REGISTER 3

U-0	U-0	R/W-0	R/W-0	R/W-0	R/W-0	R/W-0	R/W-0
—	—	RP41R<5:0>					
bit 15							bit 8

U-0	U-0	R/W-0	R/W-0	R/W-0	R/W-0	R/W-0	R/W-0
—	—	RP40R<5:0>					
bit 7							bit 0

Legend:

R = Readable bit W = Writable bit U = Unimplemented bit, read as '0'
 -n = Value at POR '1' = Bit is set '0' = Bit is cleared x = Bit is unknown

- bit 15-14 **Unimplemented:** Read as '0'
- bit 13-8 **RP41R<5:0>:** Peripheral Output Function is Assigned to RP41 Output Pin bits
 (see [Table 11-3](#) for peripheral function numbers)
- bit 7-6 **Unimplemented:** Read as '0'
- bit 5-0 **RP40R<5:0>:** Peripheral Output Function is Assigned to RP40 Output Pin bits
 (see [Table 11-3](#) for peripheral function numbers)

REGISTER 11-34: RPOR4: PERIPHERAL PIN SELECT OUTPUT REGISTER 4

U-0	U-0	R/W-0	R/W-0	R/W-0	R/W-0	R/W-0	R/W-0
—	—	RP43R<5:0>					
bit 15							bit 8

U-0	U-0	R/W-0	R/W-0	R/W-0	R/W-0	R/W-0	R/W-0
—	—	RP42R<5:0>					
bit 7							bit 0

Legend:			
R = Readable bit	W = Writable bit	U = Unimplemented bit, read as '0'	
-n = Value at POR	'1' = Bit is set	'0' = Bit is cleared	x = Bit is unknown

- bit 15-14 **Unimplemented:** Read as '0'
- bit 13-8 **RP43R<5:0>:** Peripheral Output Function is Assigned to RP43 Output Pin bits
(see [Table 11-3](#) for peripheral function numbers)
- bit 7-6 **Unimplemented:** Read as '0'
- bit 5-0 **RP42R<5:0>:** Peripheral Output Function is Assigned to RP42 Output Pin bits
(see [Table 11-3](#) for peripheral function numbers)

REGISTER 11-35: RPOR5: PERIPHERAL PIN SELECT OUTPUT REGISTER 5

U-0	U-0	R/W-0	R/W-0	R/W-0	R/W-0	R/W-0	R/W-0
—	—	RP49R<5:0>					
bit 15							bit 8

U-0	U-0	R/W-0	R/W-0	R/W-0	R/W-0	R/W-0	R/W-0
—	—	RP48R<5:0>					
bit 7							bit 0

Legend:			
R = Readable bit	W = Writable bit	U = Unimplemented bit, read as '0'	
-n = Value at POR	'1' = Bit is set	'0' = Bit is cleared	x = Bit is unknown

- bit 15-14 **Unimplemented:** Read as '0'
- bit 13-8 **RP49R<5:0>:** Peripheral Output Function is Assigned to RP49 Output Pin bits
(see [Table 11-3](#) for peripheral function numbers)
- bit 7-6 **Unimplemented:** Read as '0'
- bit 5-0 **RP48R<5:0>:** Peripheral Output Function is Assigned to RP48 Output Pin bits
(see [Table 11-3](#) for peripheral function numbers)

dsPIC33EPXXXGM3XX/6XX/7XX

REGISTER 11-36: RPOR6: PERIPHERAL PIN SELECT OUTPUT REGISTER 6

U-0	U-0	R/W-0	R/W-0	R/W-0	R/W-0	R/W-0	R/W-0
—	—	RP55R<5:0>					
bit 15							bit 8

U-0	U-0	R/W-0	R/W-0	R/W-0	R/W-0	R/W-0	R/W-0
—	—	RP54R<5:0>					
bit 7							bit 0

Legend:

R = Readable bit W = Writable bit U = Unimplemented bit, read as '0'
 -n = Value at POR '1' = Bit is set '0' = Bit is cleared x = Bit is unknown

- bit 15-14 **Unimplemented:** Read as '0'
- bit 13-8 **RP55R<5:0>:** Peripheral Output Function is Assigned to RP55 Output Pin bits
 (see [Table 11-3](#) for peripheral function numbers)
- bit 7-6 **Unimplemented:** Read as '0'
- bit 5-0 **RP54R<5:0>:** Peripheral Output Function is Assigned to RP54 Output Pin bits
 (see [Table 11-3](#) for peripheral function numbers)

REGISTER 11-37: RPOR7: PERIPHERAL PIN SELECT OUTPUT REGISTER 7

U-0	U-0	R/W-0	R/W-0	R/W-0	R/W-0	R/W-0	R/W-0
—	—	RP57R<5:0>					
bit 15							bit 8

U-0	U-0	R/W-0	R/W-0	R/W-0	R/W-0	R/W-0	R/W-0
—	—	RP56R<5:0>					
bit 7							bit 0

Legend:

R = Readable bit W = Writable bit U = Unimplemented bit, read as '0'
 -n = Value at POR '1' = Bit is set '0' = Bit is cleared x = Bit is unknown

- bit 15-14 **Unimplemented:** Read as '0'
- bit 13-8 **RP57R<5:0>:** Peripheral Output Function is Assigned to RP57 Output Pin bits
 (see [Table 11-3](#) for peripheral function numbers)
- bit 7-6 **Unimplemented:** Read as '0'
- bit 5-0 **RP56R<5:0>:** Peripheral Output Function is Assigned to RP56 Output Pin bits
 (see [Table 11-3](#) for peripheral function numbers)

dsPIC33EPXXXGM3XX/6XX/7XX

REGISTER 11-38: RPOR8: PERIPHERAL PIN SELECT OUTPUT REGISTER 8⁽¹⁾

U-0	U-0	R/W-0	R/W-0	R/W-0	R/W-0	R/W-0	R/W-0
—	—	RP70R<5:0>					
bit 15							bit 8

U-0	U-0	R/W-0	R/W-0	R/W-0	R/W-0	R/W-0	R/W-0
—	—	RP69R<5:0>					
bit 7							bit 0

Legend:

R = Readable bit W = Writable bit U = Unimplemented bit, read as '0'
 -n = Value at POR '1' = Bit is set '0' = Bit is cleared x = Bit is unknown

- bit 15-14 **Unimplemented:** Read as '0'
- bit 13-8 **RP70R<5:0>:** Peripheral Output Function is Assigned to RP70 Output Pin bits
 (see [Table 11-3](#) for peripheral function numbers)
- bit 7-6 **Unimplemented:** Read as '0'
- bit 5-0 **RP69R<5:0>:** Peripheral Output Function is Assigned to RP69 Output Pin bits
 (see [Table 11-3](#) for peripheral function numbers)

Note 1: This register is not available on dsPIC33EPXXXGM304/604 devices.

REGISTER 11-39: RPOR9: PERIPHERAL PIN SELECT OUTPUT REGISTER 9⁽¹⁾

U-0	U-0	R/W-0	R/W-0	R/W-0	R/W-0	R/W-0	R/W-0
—	—	RP97R<5:0>					
bit 15							bit 8

U-0	U-0	R/W-0	R/W-0	R/W-0	R/W-0	R/W-0	R/W-0
—	—	RP81R<5:0> ⁽²⁾					
bit 7							bit 0

Legend:

R = Readable bit W = Writable bit U = Unimplemented bit, read as '0'
 -n = Value at POR '1' = Bit is set '0' = Bit is cleared x = Bit is unknown

- bit 15-14 **Unimplemented:** Read as '0'
- bit 13-8 **RP97R<5:0>:** Peripheral Output Function is Assigned to RP97 Output Pin bits
 (see [Table 11-3](#) for peripheral function numbers)
- bit 7-6 **Unimplemented:** Read as '0'
- bit 5-0 **RP81R<5:0>:** Peripheral Output Function is Assigned to RP81 Output Pin bits⁽²⁾
 (see [Table 11-3](#) for peripheral function numbers)

Note 1: This register is not available on dsPIC33EPXXXGM304/604 devices.

2: These bits are not available on dsPIC33EPXXXGM306/706 devices.

dsPIC33EPXXXGM3XX/6XX/7XX

REGISTER 11-40: RPOR10: PERIPHERAL PIN SELECT OUTPUT REGISTER 10⁽¹⁾

U-0	U-0	R/W-0	R/W-0	R/W-0	R/W-0	R/W-0	R/W-0
—	—	RP118R<5:0>					
bit 15							bit 8

U-0	U-0	R/W-0	R/W-0	R/W-0	R/W-0	R/W-0	R/W-0
—	—	RP113R<5:0>					
bit 7							bit 0

Legend:

R = Readable bit

W = Writable bit

U = Unimplemented bit, read as '0'

-n = Value at POR

'1' = Bit is set

'0' = Bit is cleared

x = Bit is unknown

bit 15-14 **Unimplemented:** Read as '0'

bit 13-8 **RP118R<5:0>:** Peripheral Output Function is Assigned to RP118 Output Pin bits
(see [Table 11-3](#) for peripheral function numbers)

bit 7-6 **Unimplemented:** Read as '0'

bit 5-0 **RP113R<5:0>:** Peripheral Output Function is Assigned to RP113 Output Pin bits
(see [Table 11-3](#) for peripheral function numbers)

Note 1: This register is not available on dsPIC33EPXXXGM30X/604/706 devices.

REGISTER 11-41: RPOR11: PERIPHERAL PIN SELECT OUTPUT REGISTER 11⁽¹⁾

U-0	U-0	R/W-0	R/W-0	R/W-0	R/W-0	R/W-0	R/W-0
—	—	RP125R<5:0>					
bit 15							bit 8

U-0	U-0	R/W-0	R/W-0	R/W-0	R/W-0	R/W-0	R/W-0
—	—	RP120R<5:0>					
bit 7							bit 0

Legend:

R = Readable bit

W = Writable bit

U = Unimplemented bit, read as '0'

-n = Value at POR

'1' = Bit is set

'0' = Bit is cleared

x = Bit is unknown

bit 15-14 **Unimplemented:** Read as '0'

bit 13-8 **RP125R<5:0>:** Peripheral Output Function is Assigned to RP125 Output Pin bits
(see [Table 11-3](#) for peripheral function numbers)

bit 7-6 **Unimplemented:** Read as '0'

bit 5-0 **RP120R<5:0>:** Peripheral Output Function is Assigned to RP120 Output Pin bits
(see [Table 11-3](#) for peripheral function numbers)

Note 1: This register is not available on dsPIC33EPXXXGM30X/604/706 devices.

dsPIC33EPXXXGM3XX/6XX/7XX

REGISTER 11-42: RPOR12: PERIPHERAL PIN SELECT OUTPUT REGISTER 12⁽¹⁾

U-0	U-0	R/W-0	R/W-0	R/W-0	R/W-0	R/W-0	R/W-0
—	—	RP127R<5:0>					
bit 15							bit 8

U-0	U-0	R/W-0	R/W-0	R/W-0	R/W-0	R/W-0	R/W-0
—	—	RP126R<5:0>					
bit 7							bit 0

Legend:

R = Readable bit

W = Writable bit

U = Unimplemented bit, read as '0'

-n = Value at POR

'1' = Bit is set

'0' = Bit is cleared

x = Bit is unknown

bit 15-14 **Unimplemented:** Read as '0'

bit 13-8 **RP127R<5:0>:** Peripheral Output Function is Assigned to RP127 Output Pin bits
(see [Table 11-3](#) for peripheral function numbers)

bit 7-6 **Unimplemented:** Read as '0'

bit 5-0 **RP126R<5:0>:** Peripheral Output Function is Assigned to RP126 Output Pin bits
(see [Table 11-3](#) for peripheral function numbers)

Note 1: This register is not available on dsPIC33EPXXXGM30X/604/706 devices.

dsPIC33EPXXGM3XX/6XX/7XX

NOTES:

12.0 TIMER1

Note 1: This data sheet summarizes the features of the dsPIC33EPXXXGM3XX/6XX/7XX family of devices. It is not intended to be a comprehensive reference source. To complement the information in this data sheet, refer to the “dsPIC33/PIC24 Family Reference Manual”, “Timers” (DS70362), which is available from the Microchip web site (www.microchip.com).

2: Some registers and associated bits described in this section may not be available on all devices. Refer to [Section 4.0 “Memory Organization”](#) in this data sheet for device-specific register and bit information.

The Timer1 module is a 16-bit timer that can operate as a free-running, interval timer/counter.

The Timer1 module has the following unique features over other timers:

- Can be operated in Asynchronous Counter mode from an external clock source
- The external clock input (T1CK) can optionally be synchronized to the internal device clock and the clock synchronization is performed after the prescaler

A block diagram of Timer1 is shown in [Figure 12-1](#).

The Timer1 module can operate in one of the following modes:

- Timer mode
- Gated Timer mode
- Synchronous Counter mode
- Asynchronous Counter mode

In Timer and Gated Timer modes, the input clock is derived from the internal instruction cycle clock (FCY). In Synchronous and Asynchronous Counter modes, the input clock is derived from the external clock input at the T1CK pin.

The Timer modes are determined by the following bits:

- Timer Clock Source Control bit (TCS): T1CON<1>
- Timer Synchronization Control bit (TSYNC): T1CON<2>
- Timer Gate Control bit (TGATE): T1CON<6>

Timer control bit settings for different operating modes are given in the [Table 12-1](#).

TABLE 12-1: TIMER MODE SETTINGS

Mode	TCS	TGATE	TSYNC
Timer	0	0	x
Gated Timer	0	1	x
Synchronous Counter	1	x	1
Asynchronous Counter	1	x	0

FIGURE 12-1: 16-BIT TIMER1 MODULE BLOCK DIAGRAM

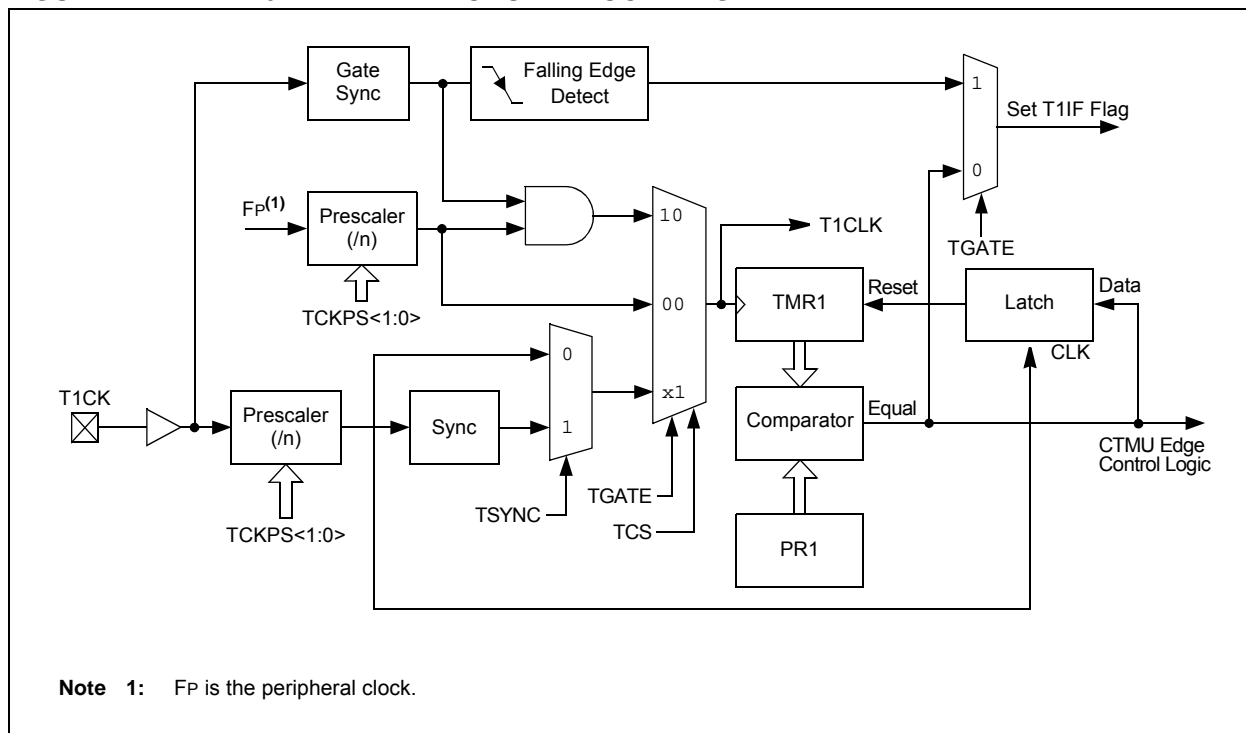

dsPIC33EPXXXGM3XX/6XX/7XX

12.1 Timer1 Control Register

REGISTER 12-1: T1CON: TIMER1 CONTROL REGISTER

R/W-0	U-0	R/W-0	U-0	U-0	U-0	U-0	U-0
TON ⁽¹⁾	—	TSIDL	—	—	—	—	—
bit 15							bit 8

U-0	R/W-0	R/W-0	R/W-0	U-0	R/W-0	R/W-0	U-0
—	TGATE	TCKPS1	TCKPS1	—	TSYNC ⁽¹⁾	TCS ⁽¹⁾	—
bit 7							bit 0

Legend:

R = Readable bit W = Writable bit U = Unimplemented bit, read as '0'
 -n = Value at POR '1' = Bit is set '0' = Bit is cleared x = Bit is unknown

- bit 15 **TON:** Timer1 On bit⁽¹⁾
 1 = Starts 16-bit Timer1
 0 = Stops 16-bit Timer1
- bit 14 **Unimplemented:** Read as '0'
- bit 13 **TSIDL:** Timer1 Stop in Idle Mode bit
 1 = Discontinues module operation when device enters Idle mode
 0 = Continues module operation in Idle mode
- bit 12-7 **Unimplemented:** Read as '0'
- bit 6 **TGATE:** Timer1 Gated Time Accumulation Enable bit
 When TCS = 1:
 This bit is ignored.
 When TCS = 0:
 1 = Gated time accumulation is enabled
 0 = Gated time accumulation is disabled
- bit 5-4 **TCKPS<1:0>:** Timer1 Input Clock Prescale Select bits
 11 = 1:256
 10 = 1:64
 01 = 1:8
 00 = 1:1
- bit 3 **Unimplemented:** Read as '0'
- bit 2 **TSYNC:** Timer1 External Clock Input Synchronization Select bit⁽¹⁾
 When TCS = 1:
 1 = Synchronizes external clock input
 0 = Does not synchronize external clock input
 When TCS = 0:
 This bit is ignored.
- bit 1 **TCS:** Timer1 Clock Source Select bit⁽¹⁾
 1 = External clock is from pin, T1CK (on the rising edge)
 0 = Internal clock (FP)
- bit 0 **Unimplemented:** Read as '0'

Note 1: When Timer1 is enabled in External Synchronous Counter mode (TCS = 1, TSYNC = 1, TON = 1), any attempts by user software to write to the TMR1 register are ignored.

13.0 TIMER2/3, TIMER4/5, TIMER6/7 AND TIMER8/9

Note 1: This data sheet summarizes the features of the dsPIC33EPXXXGM3XX/6XX/7XX family of devices. It is not intended to be a comprehensive reference source. To complement the information in this data sheet, refer to the “dsPIC33/PIC24 Family Reference Manual”, “Timers” (DS70362), which is available from the Microchip web site (www.microchip.com).

2: Some registers and associated bits described in this section may not be available on all devices. Refer to [Section 4.0 “Memory Organization”](#) in this data sheet for device-specific register and bit information.

The Timer2/3, Timer4/5, Timer6/7 and Timer8/9 modules are 32-bit timers, which can also be configured as eight independent 16-bit timers with selectable operating modes.

As a 32-bit timer, Timer2/3, Timer4/5, Timer6/7 and Timer8/9 operate in three modes:

- Two Independent 16-Bit Timers (e.g., Timer2 and Timer3) with All 16-Bit Operating modes (except Asynchronous Counter mode)
- Single 32-Bit Timer
- Single 32-Bit Synchronous Counter

They also support these features:

- Timer Gate Operation
- Selectable Prescaler Settings
- Timer Operation during Idle and Sleep modes
- Interrupt on a 32-Bit Period Register Match
- Time Base for Input Capture and Output Compare modules
- ADC1 Event Trigger (Timer2/3 only)

Individually, all eight of the 16-bit timers can function as synchronous timers or counters. They also offer the features listed previously, except for the event trigger; this is implemented only with Timer2/3. The operating modes and enabled features are determined by setting the appropriate bit(s) in the T2CON, T3CON, T4CON, T5CON, T6CON, T7CON, T8CON and T9CON registers. T2CON, T4CON, T6CON and T8CON are shown in generic form in [Register 13-1](#). T3CON, T5CON, T7CON and T9CON are shown in [Register 13-2](#).

For 32-bit timer/counter operation, Timer2, Timer4, Timer6 and Timer8 are the least significant word (lsw); Timer3, Timer5, Timer7 and Timer9 are the most significant word (msw) of the 32-bit timers.

Note: For 32-bit operation, T3CON, T5CON, T7CON and T9CON register control bits are ignored. Only T2CON, T4CON, T6CON and T8CON register control bits are used for setup and control. Timer2, Timer4, Timer6 and Timer8 clock and gate inputs are utilized for the 32-bit timer modules, but an interrupt is generated with the Timer3, Timer5, Timer7 and Timer9 interrupt flags.

A block diagram for an example of a 32-bit timer pair (Timer2/3 and Timer4/5) is shown in [Figure 13-3](#).

Note: Only Timer2, 3, 4 and 5 can trigger a DMA data transfer.

dsPIC33EPXXGM3XX/6XX/7XX

FIGURE 13-1: TYPE B TIMER BLOCK DIAGRAM (x = 2, 4, 6 AND 8)

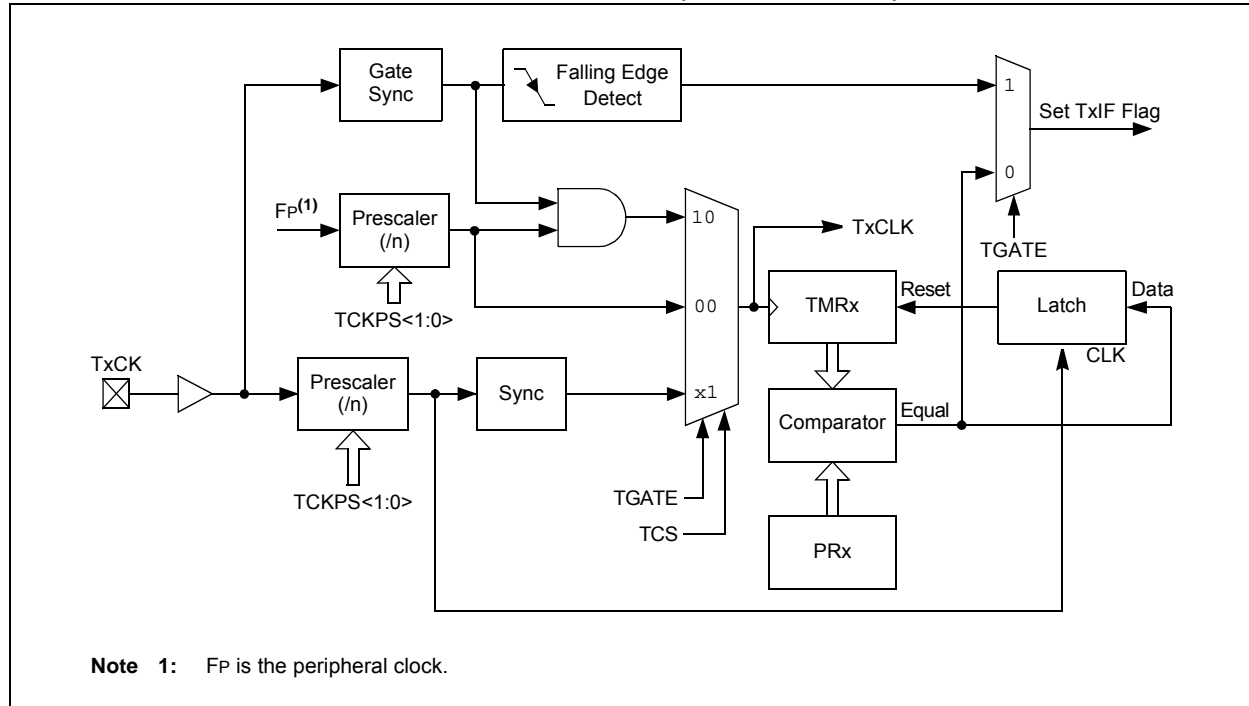

FIGURE 13-2: TYPE C TIMER BLOCK DIAGRAM (x = 3, 5, 7 AND 9)

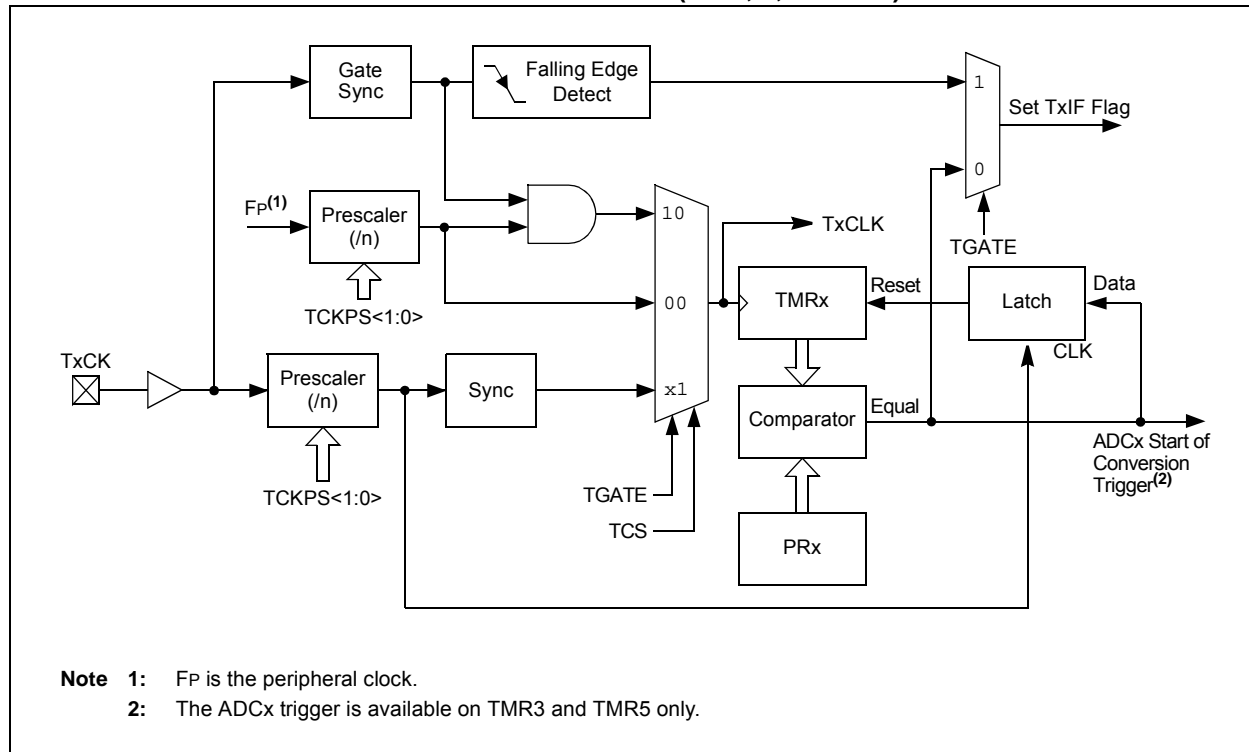
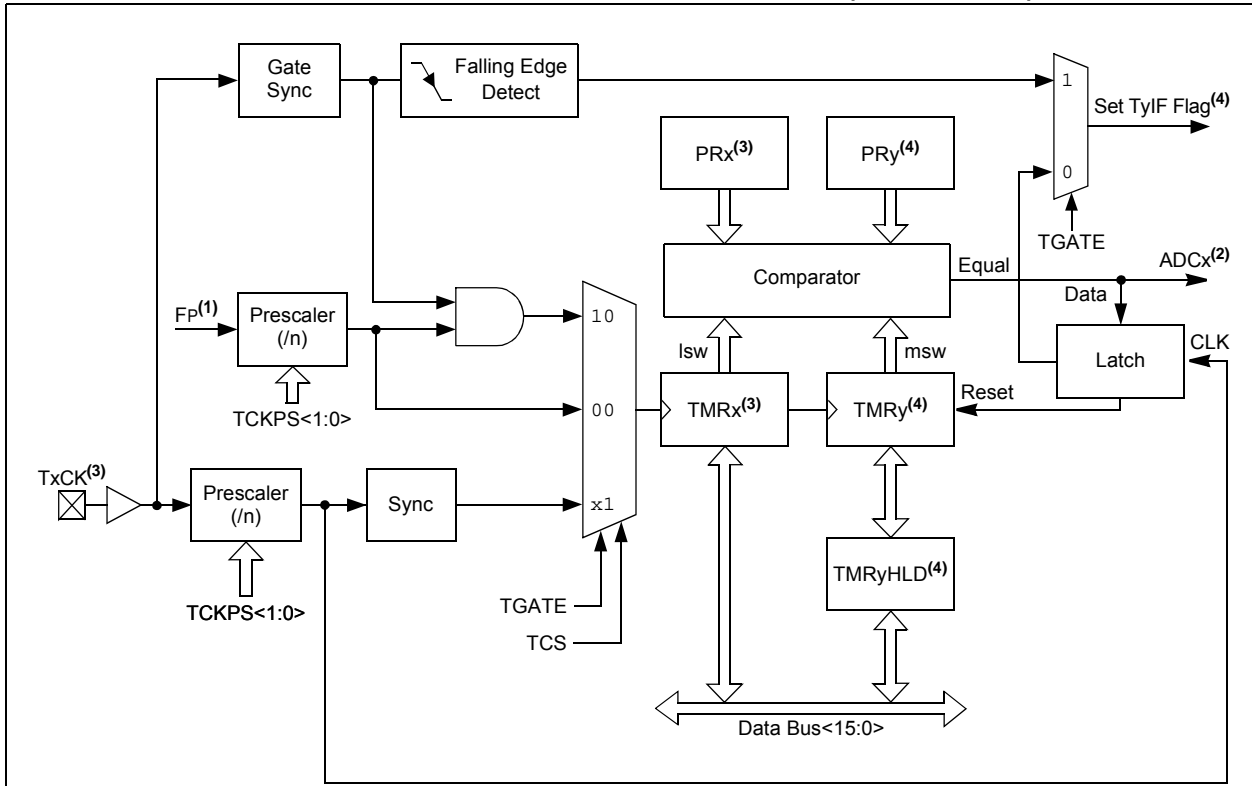

FIGURE 13-3: TYPE B/TIME C TIMER PAIR BLOCK DIAGRAM (32-BIT TIMER)



- Note**
- 1: Fp is the peripheral clock.
 - 2: The ADCx trigger is available only on the TMR3:TMR2 and TMR5:TMR4 32-bit timer pairs.
 - 3: Timerx is a Type B timer (x = 2 and 4).
 - 4: Timery is a Type C timer (x = 3 and 5).

dsPIC33EPXXXGM3XX/6XX/7XX

13.1 Timer Control Registers

REGISTER 13-1: TxCON (T2CON, T4CON, T6CON AND T8CON) CONTROL REGISTER

R/W-0	U-0	R/W-0	U-0	U-0	U-0	U-0	U-0
TON	—	TSIDL	—	—	—	—	—
bit 15							bit 8

U-0	R/W-0	R/W-0	R/W-0	R/W-0	U-0	R/W-0	U-0
—	TGATE	TCKPS1	TCKPS0	T32	—	TCS ⁽¹⁾	—
bit 7							bit 0

Legend:

R = Readable bit W = Writable bit U = Unimplemented bit, read as '0'
 -n = Value at POR '1' = Bit is set '0' = Bit is cleared x = Bit is unknown

- bit 15 **TON:** Timerx On bit
 When T32 = 1:
 1 = Starts 32-bit Timerx/y
 0 = Stops 32-bit Timerx/y
 When T32 = 0:
 1 = Starts 16-bit Timerx
 0 = Stops 16-bit Timerx
- bit 14 **Unimplemented:** Read as '0'
- bit 13 **TSIDL:** Timerx Stop in Idle Mode bit
 1 = Discontinues module operation when device enters Idle mode
 0 = Continues module operation in Idle mode
- bit 12-7 **Unimplemented:** Read as '0'
- bit 6 **TGATE:** Timerx Gated Time Accumulation Enable bit
 When TCS = 1:
 This bit is ignored.
 When TCS = 0:
 1 = Gated time accumulation is enabled
 0 = Gated time accumulation is disabled
- bit 5-4 **TCKPS<1:0>:** Timerx Input Clock Prescale Select bits
 11 = 1:256
 10 = 1:64
 01 = 1:8
 00 = 1:1
- bit 3 **T32:** 32-Bit Timer Mode Select bit
 1 = Timerx and Timery form a single 32-bit timer
 0 = Timerx and Timery act as two 16-bit timers
- bit 2 **Unimplemented:** Read as '0'
- bit 1 **TCS:** Timerx Clock Source Select bit⁽¹⁾
 1 = External clock is from pin, TxCK (on the rising edge)
 0 = Internal clock (FP)
- bit 0 **Unimplemented:** Read as '0'

Note 1: The TxCK pin is not available on all timers. Refer to the “Pin Diagrams” section for the available pins.

REGISTER 13-2: TyCON (T3CON, T5CON, T7CON AND T9CON) CONTROL REGISTER

R/W-0	U-0	R/W-0	U-0	U-0	U-0	U-0	U-0
TON ⁽¹⁾	—	TSIDL ⁽²⁾	—	—	—	—	—
bit 15							bit 8

U-0	R/W-0	R/W-0	R/W-0	U-0	U-0	R/W-0	U-0
—	TGATE ⁽¹⁾	TCKPS1 ⁽¹⁾	TCKPS0 ⁽¹⁾	—	—	TCS ^(1,3)	—
bit 7							bit 0

Legend:			
R = Readable bit	W = Writable bit	U = Unimplemented bit, read as '0'	
-n = Value at POR	'1' = Bit is set	'0' = Bit is cleared	x = Bit is unknown

- bit 15 **TON:** Timery On bit⁽¹⁾
 1 = Starts 16-bit Timery
 0 = Stops 16-bit Timery
- bit 14 **Unimplemented:** Read as '0'
- bit 13 **TSIDL:** Timery Stop in Idle Mode bit⁽²⁾
 1 = Discontinues module operation when device enters Idle mode
 0 = Continues module operation in Idle mode
- bit 12-7 **Unimplemented:** Read as '0'
- bit 6 **TGATE:** Timery Gated Time Accumulation Enable bit⁽¹⁾
 When TCS = 1:
 This bit is ignored.
 When TCS = 0:
 1 = Gated time accumulation is enabled
 0 = Gated time accumulation is disabled
- bit 5-4 **TCKPS<1:0>:** Timery Input Clock Prescale Select bits⁽¹⁾
 11 = 1:256
 10 = 1:64
 01 = 1:8
 00 = 1:1
- bit 3-2 **Unimplemented:** Read as '0'
- bit 1 **TCS:** Timery Clock Source Select bit^(1,3)
 1 = External clock from pin, TyCK (on the rising edge)
 0 = Internal clock (FP)
- bit 0 **Unimplemented:** Read as '0'

- Note 1:** When 32-bit operation is enabled (T2CON<3> = 1), these bits have no effect on Timery operation; all timer functions are set through TxCON.
- 2:** When 32-bit timer operation is enabled (T32 = 1) in the Timerx Control register (TxCON<3>), the TSIDL bit must be cleared to operate the 32-bit timer in Idle mode.
- 3:** The TyCK pin is not available on all timers. See the “[Pin Diagrams](#)” section for the available pins.

dsPIC33EPXXGM3XX/6XX/7XX

NOTES:

14.0 INPUT CAPTURE

Note 1: This data sheet summarizes the features of the dsPIC33EPXXXGM3XX/6XX/7XX family of devices. It is not intended to be a comprehensive reference source. To complement the information in this data sheet, refer to the “dsPIC33/PIC24 Family Reference Manual”, “Input Capture” (DS70000352), which is available from the Microchip web site (www.microchip.com).

2: Some registers and associated bits described in this section may not be available on all devices. Refer to **Section 4.0 “Memory Organization”** in this data sheet for device-specific register and bit information.

The input capture module is useful in applications requiring frequency (period) and pulse measurement. The dsPIC33EPXXXGM3XX/6XX/7XX devices support up to eight input capture channels.

Key features of the input capture module include:

- Hardware configurable for 32-bit operation in all modes by cascading two adjacent modules
- Synchronous and Trigger modes of output compare operation, with up to 31 user-selectable Trigger/Sync sources available
- A 4-level FIFO buffer for capturing and holding timer values for several events
- Configurable interrupt generation
- Up to six clock sources available for each module, driving a separate internal 16-bit counter

FIGURE 14-1: INPUT CAPTURE x MODULE BLOCK DIAGRAM

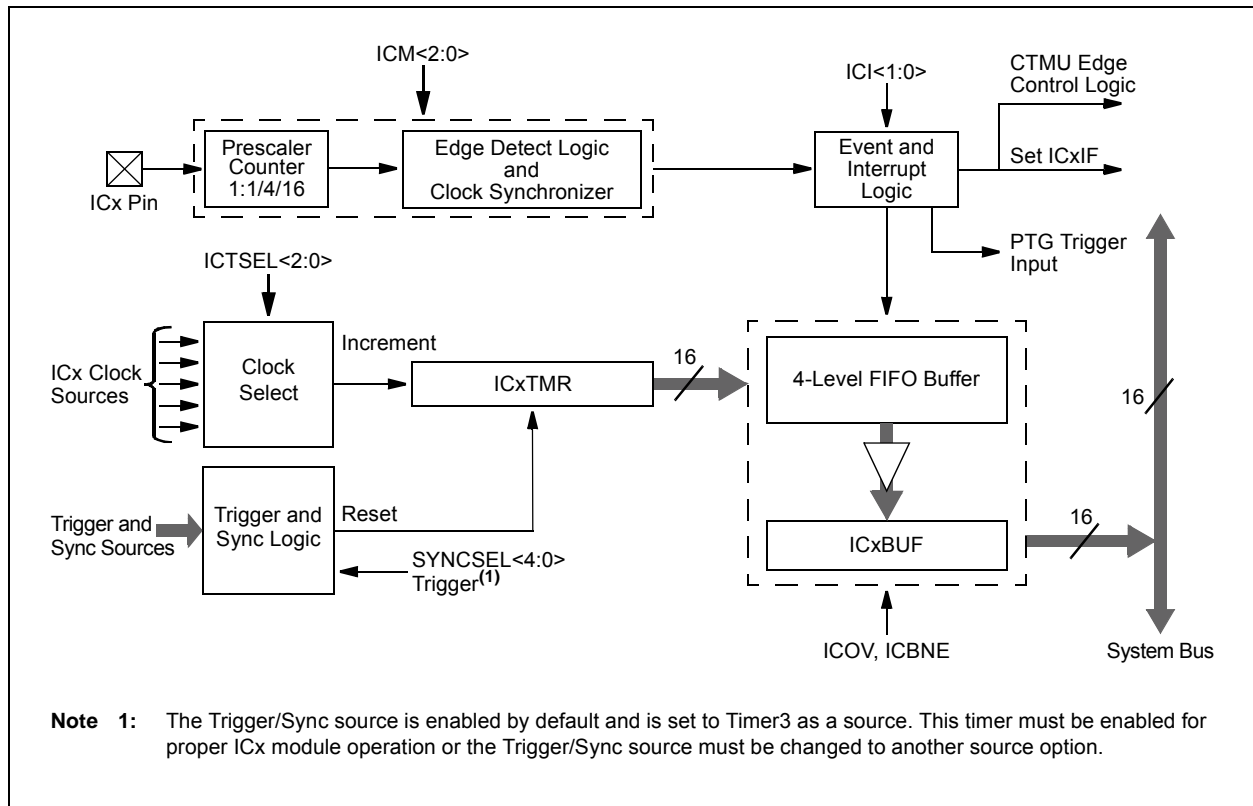

dsPIC33EPXXXGM3XX/6XX/7XX

14.1 Input Capture Control Registers

REGISTER 14-1: ICxCON1: INPUT CAPTURE x CONTROL REGISTER 1

U-0	U-0	R/W-0	R/W-0	R/W-0	R/W-0	U-0	U-0
—	—	ICSIDL	ICTSEL2	ICTSEL1	ICTSEL0	—	—
bit 15						bit 8	

U-0	R/W-0	R/W-0	R/HC/HS-0	R/HC/HS-0	R/W-0	R/W-0	R/W-0
—	ICI1	ICI0	ICOV	ICBNE	ICM2	ICM1	ICM0
bit 7							bit 0

Legend:	HC = Hardware Clearable bit	HS = Hardware Settable bit
R = Readable bit	W = Writable bit	U = Unimplemented bit, read as '0'
-n = Value at POR	'1' = Bit is set	'0' = Bit is cleared
		x = Bit is unknown

bit 15-14 **Unimplemented:** Read as '0'

bit 13 **ICSIDL:** Input Capture x Stop in Idle Mode Control bit
 1 = Input Capture x halts in CPU Idle mode
 0 = Input Capture x continues to operate in CPU Idle mode

bit 12-10 **ICTSEL<2:0>:** Input Capture x Timer Select bits
 111 = Peripheral clock (FP) is the clock source of ICx
 110 = Reserved
 101 = Reserved
 100 = T1CLK is the clock source of ICx (only the synchronous clock is supported)
 011 = T5CLK is the clock source of ICx
 010 = T4CLK is the clock source of ICx
 001 = T2CLK is the clock source of ICx
 000 = T3CLK is the clock source of ICx

bit 9-7 **Unimplemented:** Read as '0'

bit 6-5 **ICI<1:0>:** Number of Captures per Interrupt Select bits
 (this field is not used if ICM<2:0> = 001 or 111)
 11 = Interrupts on every fourth capture event
 10 = Interrupts on every third capture event
 01 = Interrupts on every second capture event
 00 = Interrupts on every capture event

bit 4 **ICOV:** Input Capture x Overflow Status Flag bit (read-only)
 1 = Input Capture x buffer overflow occurred
 0 = No Input Capture x buffer overflow occurred

bit 3 **ICBNE:** Input Capture x Buffer Not Empty Status bit (read-only)
 1 = Input Capture x buffer is not empty, at least one more capture value can be read
 0 = Input Capture x buffer is empty

bit 2-0 **ICM<2:0>:** Input Capture x Mode Select bits
 111 = Input Capture x functions as an interrupt pin only in CPU Sleep and Idle modes (rising edge detect only, all other control bits are not applicable)
 110 = Unused (module disabled)
 101 = Capture mode, every 16th rising edge (Prescaler Capture mode)
 100 = Capture mode, every 4th rising edge (Prescaler Capture mode)
 011 = Capture mode, every rising edge (Simple Capture mode)
 010 = Capture mode, every falling edge (Simple Capture mode)
 001 = Capture mode, every edge, rising and falling (Edge Detect mode, ICI<1:0>), is not used in this mode)
 000 = Input Capture x module is turned off

REGISTER 14-2: ICxCON2: INPUT CAPTURE x CONTROL REGISTER 2

U-0	U-0	U-0	U-0	U-0	U-0	U-0	R/W-0
—	—	—	—	—	—	—	IC32 ⁽¹⁾
bit 15							bit 8

R/W-0	R/W/HS-0	U-0	R/W-0	R/W-1	R/W-1	R/W-0	R/W-1
ICTRIG ⁽²⁾	TRIGSTAT ⁽³⁾	—	SYNCSEL4 ⁽⁴⁾	SYNCSEL3 ⁽⁴⁾	SYNCSEL2 ⁽⁴⁾	SYNCSEL1 ⁽⁴⁾	SYNCSEL0 ⁽⁴⁾
bit 7							bit 0

Legend:	HS = Hardware Settable bit
R = Readable bit	W = Writable bit
-n = Value at POR	'1' = Bit is set
	U = Unimplemented bit, read as '0'
	'0' = Bit is cleared
	x = Bit is unknown

- bit 15-9 **Unimplemented:** Read as '0'
- bit 8 **IC32:** Input Capture x 32-Bit Timer Mode Select bit (Cascade mode)⁽¹⁾
 - 1 = Odd ICx and Even ICx form a single 32-bit input capture module
 - 0 = Cascade module operation is disabled
- bit 7 **ICTRIG:** Input Capture x Trigger Operation Select bit⁽²⁾
 - 1 = Input source is used to trigger the input capture timer (Trigger mode)
 - 0 = Input source is used to synchronize the input capture timer to the timer of another module (Synchronization mode)
- bit 6 **TRIGSTAT:** Timer Trigger Status bit⁽³⁾
 - 1 = ICxTMR has been triggered and is running
 - 0 = ICxTMR has not been triggered and is being held clear
- bit 5 **Unimplemented:** Read as '0'

- Note 1:** The IC32 bit in both the Odd and Even ICx must be set to enable Cascade mode.
- Note 2:** The input source is selected by the SYNCSEL<4:0> bits of the ICxCON2 register.
- Note 3:** This bit is set by the selected input source (selected by SYNCSEL<4:0> bits); it can be read, set and cleared in software.
- Note 4:** Do not use the ICx module as its own Sync or Trigger source.
- Note 5:** This option should only be selected as a trigger source and not as a synchronization source.
- Note 6:** Each Input Capture x module (ICx) has one PTG input source. See [Section 25.0 “Peripheral Trigger Generator \(PTG\) Module”](#) for more information.
- PTGO8 = IC1, IC5
 - PTGO9 = IC2, IC6
 - PTGO10 = IC3, IC7
 - PTGO11 = IC4, IC8

REGISTER 14-2: ICxCON2: INPUT CAPTURE x CONTROL REGISTER 2 (CONTINUED)

bit 4-0 **SYNCSEL<4:0>**: Input Source Select for Synchronization and Trigger Operation bits⁽⁴⁾

11111 = Capture timer is unsynchronized
11110 = Capture timer is unsynchronized
11101 = Capture timer is unsynchronized
11100 = CTMU trigger is the source for the capture timer synchronization
11011 = ADC1 interrupt is the source for the capture timer synchronization⁽⁵⁾
11010 = Analog Comparator 3 is the source for the capture timer synchronization⁽⁵⁾
11001 = Analog Comparator 2 is the source for the capture timer synchronization⁽⁵⁾
11000 = Analog Comparator 1 is the source for the capture timer synchronization⁽⁵⁾
10111 = Input Capture 8 interrupt is the source for the capture timer synchronization
10110 = Input Capture 7 interrupt is the source for the capture timer synchronization
10101 = Input Capture 6 interrupt is the source for the capture timer synchronization
10100 = Input Capture 5 interrupt is the source for the capture timer synchronization
10011 = Input Capture 4 interrupt is the source for the capture timer synchronization
10010 = Input Capture 3 interrupt is the source for the capture timer synchronization
10001 = Input Capture 2 interrupt is the source for the capture timer synchronization
10000 = Input Capture 1 interrupt is the source for the capture timer synchronization
01111 = GP Timer5 is the source for the capture timer synchronization
01110 = GP Timer4 is the source for the capture timer synchronization
01101 = GP Timer3 is the source for the capture timer synchronization
01100 = GP Timer2 is the source for the capture timer synchronization
01011 = GP Timer1 is the source for the capture timer synchronization
01010 = PTGx trigger is the source for the capture timer synchronization⁽⁶⁾
01001 = Capture timer is unsynchronized
01000 = Output Compare 8 is the source for the capture timer synchronization
00111 = Output Compare 7 is the source for the capture timer synchronization
00110 = Output Compare 6 is the source for the capture timer synchronization
00101 = Output Compare 5 is the source for the capture timer synchronization
00100 = Output Compare 4 is the source for the capture timer synchronization
00011 = Output Compare 3 is the source for the capture timer synchronization
00010 = Output Compare 2 is the source for the capture timer synchronization
00001 = Output Compare 1 is the source for the capture timer synchronization
00000 = Capture timer is unsynchronized

- Note 1:** The IC32 bit in both the Odd and Even ICx must be set to enable Cascade mode.
2: The input source is selected by the SYNCSEL<4:0> bits of the ICxCON2 register.
3: This bit is set by the selected input source (selected by SYNCSEL<4:0> bits); it can be read, set and cleared in software.
4: Do not use the ICx module as its own Sync or Trigger source.
5: This option should only be selected as a trigger source and not as a synchronization source.
6: Each Input Capture x module (ICx) has one PTG input source. See [Section 25.0 “Peripheral Trigger Generator \(PTG\) Module”](#) for more information.
PTGO8 = IC1, IC5
PTGO9 = IC2, IC6
PTGO10 = IC3, IC7
PTGO11 = IC4, IC8

15.0 OUTPUT COMPARE

Note 1: This data sheet summarizes the features of the dsPIC33EPXXXGM3XX/6XX/7XX family of devices. It is not intended to be a comprehensive reference source. To complement the information in this data sheet, refer to the “dsPIC33/PIC24E Family Reference Manual”, “**Output Compare**” (DS70005157), which is available from the Microchip web site (www.microchip.com).

2: Some registers and associated bits described in this section may not be available on all devices. Refer to **Section 4.0 “Memory Organization”** in this data sheet for device-specific register and bit information.

The output compare module can select one of eight available clock sources for its time base. The module compares the value of the timer with the value of one or two Compare registers depending on the operating mode selected. The state of the output pin changes when the timer value matches the Compare register value. The output compare module generates either a single output pulse, or a sequence of output pulses, by changing the state of the output pin on the compare match events. The output compare module can also generate interrupts on compare match events and trigger DMA data transfers.

Note: See the “dsPIC33/PIC24 Family Reference Manual”, “**Output Compare**” (DS70005157) for OCxR and OCxRS register restrictions.

FIGURE 15-1: OUTPUT COMPARE x MODULE BLOCK DIAGRAM

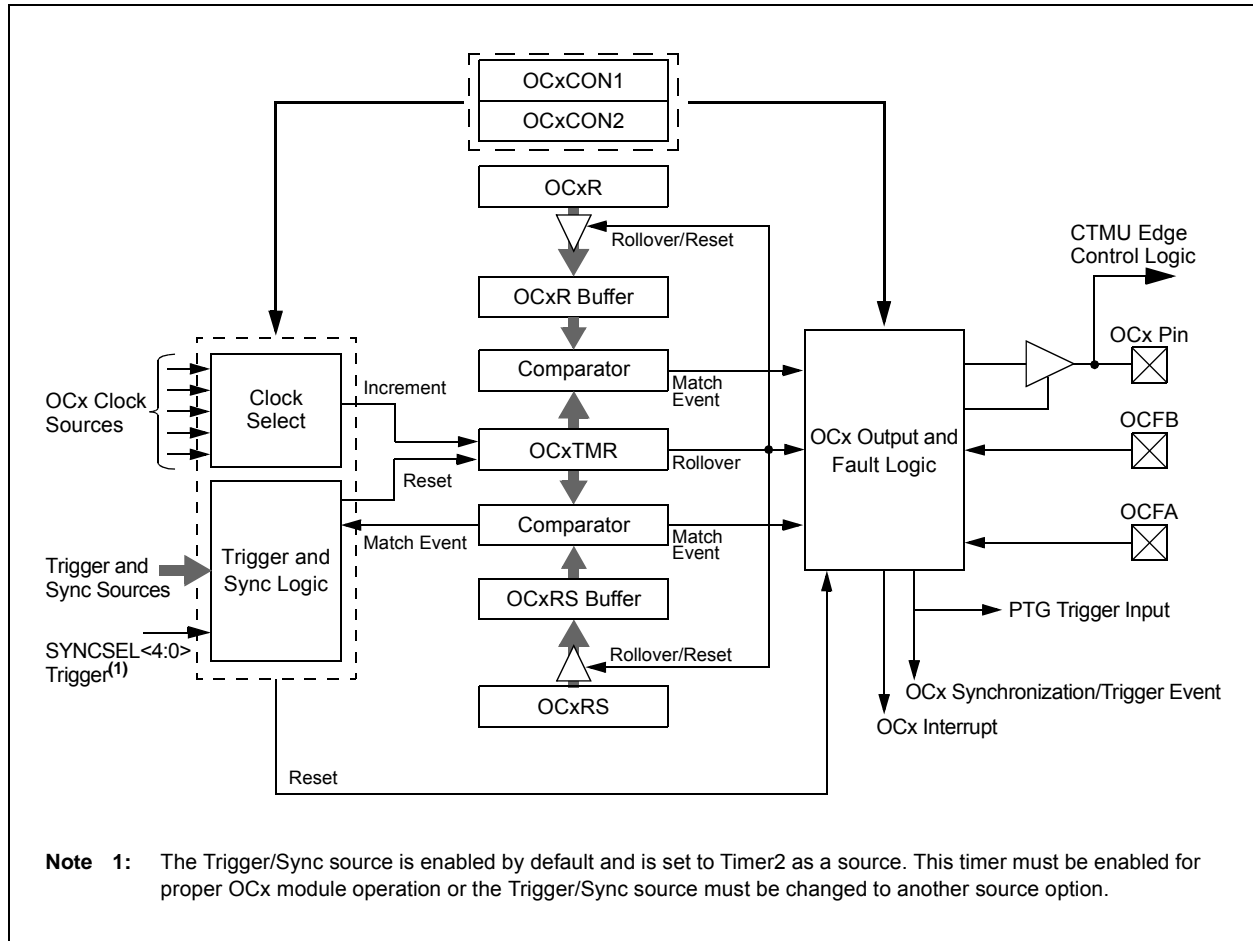

dsPIC33EPXXXGM3XX/6XX/7XX

15.1 Output Compare Control Registers

REGISTER 15-1: OCxCON1: OUTPUT COMPARE x CONTROL REGISTER 1

U-0	U-0	R/W-0	R/W-0	R/W-0	R/W-0	U-0	R/W-0
—	—	OCSIDL	OCTSEL2	OCTSEL1	OCTSEL0	—	ENFLT B
bit 15							bit 8

R/W-0	U-0	R/W-0, HSC	R/W-0, HSC	R/W-0	R/W-0	R/W-0	R/W-0
ENFLTA	—	OCFLTB	OCFLTA	TRIGMODE	OCM2	OCM1	OCM0
bit 7							bit 0

Legend:	HSC = Hardware Settable/Clearable bit		
R = Readable bit	W = Writable bit	U = Unimplemented bit, read as '0'	
-n = Value at POR	'1' = Bit is set	'0' = Bit is cleared	x = Bit is unknown

- bit 15-14 **Unimplemented:** Read as '0'
- bit 13 **OCSIDL:** Output Compare x Stop in Idle Mode Control bit
 - 1 = Output Compare x halts in CPU Idle mode
 - 0 = Output Compare x continues to operate in CPU Idle mode
- bit 12-10 **OCTSEL<2:0>:** Output Compare x Clock Select bits
 - 111 = Peripheral clock (FP)
 - 110 = Reserved
 - 101 = PTGOx clock⁽²⁾
 - 100 = T1CLK is the clock source of OCx (only the synchronous clock is supported)
 - 011 = T5CLK is the clock source of OCx
 - 010 = T4CLK is the clock source of OCx
 - 001 = T3CLK is the clock source of OCx
 - 000 = T2CLK is the clock source of OCx
- bit 9 **Unimplemented:** Read as '0'
- bit 8 **ENFLT B:** Fault B Input Enable bit
 - 1 = Output Compare x Fault B input (OCFB) is enabled
 - 0 = Output Compare x Fault B input (OCFB) is disabled
- bit 7 **ENFLTA:** Fault A Input Enable bit
 - 1 = Output Compare x Fault A input (OCFA) is enabled
 - 0 = Output Compare x Fault A input (OCFA) is disabled
- bit 6 **Unimplemented:** Read as '0'
- bit 5 **OCFLTB:** PWM Fault B Condition Status bit
 - 1 = PWM Fault B condition on OCFB pin has occurred
 - 0 = No PWM Fault B condition on OCFB pin has occurred
- bit 4 **OCFLTA:** PWM Fault A Condition Status bit
 - 1 = PWM Fault A condition on OCFA pin has occurred
 - 0 = No PWM Fault A condition on OCFA pin has occurred

- Note 1:** OCxR and OCxRS are double-buffered in PWM mode only.
- Note 2:** Each Output Compare x module (OCx) has one PTG clock source. See [Section 25.0 “Peripheral Trigger Generator \(PTG\) Module”](#) for more information.
- PTGO4 = OC1, OC5
 - PTGO5 = OC2, OC6
 - PTGO6 = OC3, OC7
 - PTGO7 = OC4, OC8

REGISTER 15-1: OCxCON1: OUTPUT COMPARE x CONTROL REGISTER 1 (CONTINUED)

- bit 3 **TRIGMODE**: Trigger Status Mode Select bit
1 = TRIGSTAT (OCxCON2<6>) is cleared when OCxRS = OCxTMR or in software
0 = TRIGSTAT is cleared only by software
- bit 2-0 **OCM<2:0>**: Output Compare x Mode Select bits
111 = Center-Aligned PWM mode: Output sets high when OCxTMR = OCxR and sets low when OCxTMR = OCxRS⁽¹⁾
110 = Edge-Aligned PWM mode: Output sets high when OCxTMR = 0 and sets low when OCxTMR = OCxR⁽¹⁾
101 = Double Compare Continuous Pulse mode: Initializes OCx pin low, toggles OCx state continuously on alternate matches of OCxR and OCxRS
100 = Double Compare Single-Shot mode: Initializes OCx pin low, toggles OCx state on matches of OCxR and OCxRS for one cycle
011 = Single Compare mode: Compare event with OCxR, continuously toggles OCx pin
010 = Single Compare Single-Shot mode: Initializes OCx pin high, compare event with OCxR, forces OCx pin low
001 = Single Compare Single-Shot mode: Initializes OCx pin low, compare event with OCxR, forces OCx pin high
000 = Output compare channel is disabled

Note 1: OCxR and OCxRS are double-buffered in PWM mode only.

2: Each Output Compare x module (OCx) has one PTG clock source. See [Section 25.0 “Peripheral Trigger Generator \(PTG\) Module”](#) for more information.

PTGO4 = OC1, OC5

PTGO5 = OC2, OC6

PTGO6 = OC3, OC7

PTGO7 = OC4, OC8

dsPIC33EPXXXGM3XX/6XX/7XX

REGISTER 15-2: OCxCON2: OUTPUT COMPARE x CONTROL REGISTER 2

R/W-0	R/W-0	R/W-0	R/W-0	U-0	U-0	U-0	R/W-0
FLTMD	FLTOUT	FLTRIEN	OCINV	—	—	—	OC32
bit 15							bit 8

R/W-0	R/W-0, HS	R/W-0	R/W-0	R/W-1	R/W-1	R/W-0	R/W-0
OCTRIG	TRIGSTAT	OCTRIS	SYNCSEL4	SYNCSEL3	SYNCSEL2	SYNCSEL1	SYNCSEL0
bit 7							bit 0

Legend:	HS = Hardware Settable bit		
R = Readable bit	W = Writable bit	U = Unimplemented bit, read as '0'	
-n = Value at POR	'1' = Bit is set	'0' = Bit is cleared	x = Bit is unknown

- bit 15 **FLTMD:** Fault Mode Select bit
 1 = Fault mode is maintained until the Fault source is removed; the corresponding OCFLTx bit is cleared in software and a new PWM period starts
 0 = Fault mode is maintained until the Fault source is removed and a new PWM period starts
- bit 14 **FLTOUT:** Fault Out bit
 1 = PWM output is driven high on a Fault
 0 = PWM output is driven low on a Fault
- bit 13 **FLTRIEN:** Fault Output State Select bit
 1 = OCx pin is tri-stated on a Fault condition
 0 = OCx pin I/O state is defined by the FLTOUT bit on a Fault condition
- bit 12 **OCINV:** OCx Invert bit
 1 = OCx output is inverted
 0 = OCx output is not inverted
- bit 11-9 **Unimplemented:** Read as '0'
- bit 8 **OC32:** Cascade Two OCx Modules Enable bit (32-bit operation)
 1 = Cascade module operation is enabled
 0 = Cascade module operation is disabled
- bit 7 **OCTRIG:** OCx Trigger/Sync Select bit
 1 = Triggers OCx from source designated by the SYNCSELx bits
 0 = Synchronizes OCx with source designated by the SYNCSELx bits
- bit 6 **TRIGSTAT:** Timer Trigger Status bit
 1 = Timer source has been triggered and is running
 0 = Timer source has not been triggered and is being held clear
- bit 5 **OCTRIS:** OCx Output Pin Direction Select bit
 1 = Output Compare x is tri-stated
 0 = Output Compare x module drives the OCx pin

- Note 1:** Do not use the OCx module as its own synchronization or trigger source.
- Note 2:** When the OCy module is turned off, it sends a trigger out signal. If the OCx module uses the OCy module as a trigger source, the OCy module must be unselected as a trigger source prior to disabling it.
- Note 3:** Each Output Compare x module (OCx) has one PTG Trigger/Sync source. See [Section 25.0 "Peripheral Trigger Generator \(PTG\) Module"](#) for more information.
 PTGO4 = OC1, OC5
 PTGO5 = OC2, OC6
 PTGO6 = OC3, OC7
 PTGO7 = OC4, OC8

REGISTER 15-2: OCxCON2: OUTPUT COMPARE x CONTROL REGISTER 2 (CONTINUED)

bit 4-0 **SYNCSEL<4:0>**: Trigger/Synchronization Source Selection bits

- 11111 = OCxRS compare event is used for synchronization
- 11110 = INT2 is the source for compare timer synchronization
- 11101 = INT1 is the source for compare timer synchronization
- 11100 = CTMU trigger is the source for compare timer synchronization
- 11011 = ADC1 interrupt is the source for compare timer synchronization
- 11010 = Analog Comparator 3 is the source for compare timer synchronization
- 11001 = Analog Comparator 2 is the source for compare timer synchronization
- 11000 = Analog Comparator 1 is the source for compare timer synchronization
- 10111 = Input Capture 8 interrupt is the source for compare timer synchronization
- 10110 = Input Capture 7 interrupt is the source for compare timer synchronization
- 10101 = Input Capture 6 interrupt is the source for compare timer synchronization
- 10100 = Input Capture 5 interrupt is the source for compare timer synchronization
- 10011 = Input Capture 4 interrupt is the source for compare timer synchronization
- 10010 = Input Capture 3 interrupt is the source for compare timer synchronization
- 10001 = Input Capture 2 interrupt is the source for compare timer synchronization
- 10000 = Input Capture 1 interrupt is the source for compare timer synchronization
- 01111 = GP Timer5 is the source for compare timer synchronization
- 01110 = GP Timer4 is the source for compare timer synchronization
- 01101 = GP Timer3 is the source for compare timer synchronization
- 01100 = GP Timer2 is the source for compare timer synchronization
- 01011 = GP Timer1 is the source for compare timer synchronization
- 01010 = PTGx trigger is the source for compare timer synchronization⁽³⁾
- 01001 = Compare timer is unsynchronized
- 01000 = Output Compare 8 is the source for compare timer synchronization^(1,2)
- 00111 = Output Compare 7 is the source for compare timer synchronization^(1,2)
- 00110 = Output Compare 6 is the source for compare timer synchronization^(1,2)
- 00101 = Output Compare 5 is the source for compare timer synchronization^(1,2)
- 00100 = Output Compare 4 is the source for compare timer synchronization^(1,2)
- 00011 = Output Compare 3 is the source for compare timer synchronization^(1,2)
- 00010 = Output Compare 2 is the source for compare timer synchronization^(1,2)
- 00001 = Output Compare 1 is the source for compare timer synchronization^(1,2)
- 00000 = Compare timer is unsynchronized

- Note 1:** Do not use the OCx module as its own synchronization or trigger source.
- 2:** When the OCy module is turned off, it sends a trigger out signal. If the OCx module uses the OCy module as a trigger source, the OCy module must be unselected as a trigger source prior to disabling it.
- 3:** Each Output Compare x module (OCx) has one PTG Trigger/Sync source. See [Section 25.0 “Peripheral Trigger Generator \(PTG\) Module”](#) for more information.
- PTGO4 = OC1, OC5
 - PTGO5 = OC2, OC6
 - PTGO6 = OC3, OC7
 - PTGO7 = OC4, OC8

dsPIC33EPXXGM3XX/6XX/7XX

NOTES:

16.0 HIGH-SPEED PWM MODULE

Note 1: This data sheet summarizes the features of the dsPIC33EPXXXGM3XX/6XX/7XX family of devices. It is not intended to be a comprehensive reference source. To complement the information in this data sheet, refer to the “dsPIC33/PIC24 Family Reference Manual”, “High-Speed PWM” (DS70645), which is available from the Microchip web site (www.microchip.com).

2: Some registers and associated bits described in this section may not be available on all devices. Refer to [Section 4.0 “Memory Organization”](#) in this data sheet for device-specific register and bit information.

The dsPIC33EPXXXGM3XX/6XX/7XX devices support a dedicated Pulse-Width Modulation (PWM) module with up to 12 outputs.

The high-speed PWMx module consists of the following major features:

- Six PWM generators
- Two PWM outputs per PWM generator
- Individual period and duty cycle for each PWM pair
- Duty cycle, dead time, phase shift and a frequency resolution of 7.14 ns
- Independent Fault and current-limit inputs for six PWM outputs
- Redundant output
- Center-Aligned PWM mode
- Output override control
- Chop mode (also known as Gated mode)
- Special Event Trigger
- Prescaler for input clock
- PWMxL and PWMxH output pin swapping
- Independent PWM frequency, duty cycle and phase-shift changes for each PWM generator
- Dead-time compensation
- Enhanced Leading-Edge Blanking (LEB) functionality
- Frequency resolution enhancement
- PWM capture functionality

Note: In Edge-Aligned PWM mode, the duty cycle, dead time, phase shift and frequency resolution are 7.14 ns.

The high-speed PWMx module contains up to six PWM generators. Each PWMx generator provides two PWM outputs: PWMxH and PWMxL. The master time base generator provides a synchronous signal as a common time base to synchronize the various PWM outputs. The individual PWM outputs are available on the output pins of the device. The input Fault signals and current-limit signals, when enabled, can monitor and protect the system by placing the PWM outputs into a known “safe” state.

Each PWMx can generate a trigger to the ADCx module to sample the analog signal at a specific instance during the PWM period. In addition, the high-speed PWMx module also generates a Special Event Trigger to the ADCx module, based on either of the two master time bases.

The high-speed PWMx module can synchronize itself with an external signal or can act as a synchronizing source to any external device. The SYNC11 and SYNC12 input pins that utilize PPS, can synchronize the high-speed PWMx module with an external signal. The SYNCO1 and SYNCO2 pins are output pins that provides a synchronous signal to an external device.

[Figure 16-1](#) illustrates an architectural overview of the high-speed PWMx module and its interconnection with the CPU and other peripherals.

16.1 PWM Faults

The PWMx module incorporates multiple external Fault inputs, which include FLT1 and FLT2. The inputs are remappable using the PPS feature. FLT3 is available on 44-pin, 64-pin and 100-pin packages; FLT4 through FLT8 are available on specific pins on 64-pin and 100-pin packages, and FLT32, which has been implemented with Class B safety features, and is available on a fixed pin on all devices.

These Faults provide a safe and reliable way to safely shut down the PWM outputs when the Fault input is asserted.

16.1.1 PWM FAULTS AT RESET

During any Reset event, the PWMx module maintains ownership of the Class B Fault, FLT32. At Reset, this Fault is enabled in Latched mode to ensure the fail-safe power-up of the application. The application software must clear the PWM Fault before enabling the high-speed motor control PWMx module. To clear the Fault condition, the FLT32 pin must first be pulled high externally or the internal pull-up resistor in the CNPULX register can be enabled.

Note: The Fault mode may be changed using the FLTMOD<1:0> bits (FCLCONx<1:0>), regardless of the state of FLT32.

dsPIC33EPXXXGM3XX/6XX/7XX

16.1.2 WRITE-PROTECTED REGISTERS

On dsPIC33EPXXXGM3XX/6XX/7XX devices, write protection is implemented for the IOCONx and FCLCONx registers. The write protection feature prevents any inadvertent writes to these registers. This protection feature can be controlled by the PWMLOCK Configuration bit (FOSCSEL<6>). The default state of the write protection feature is enabled (PWMLOCK = 1). The write protection feature can be disabled by configuring: PWMLOCK = 0.

To gain write access to these locked registers, the user application must write two consecutive values of 0xABCD and 0x4321 to the PWMKEY register to perform the unlock operation. The write access to the IOCONx or FCLCONx registers must be the next SFR access following the unlock process. There can be no other SFR accesses during the unlock process and subsequent write access. To write to both the IOCONx and FCLCONx registers requires two unlock operations.

The correct unlocking sequence is described in [Example 16-1](#).

EXAMPLE 16-1: PWM1 WRITE-PROTECTED REGISTER UNLOCK SEQUENCE

```
; FLT32 pin must be pulled high externally in order to clear and disable the fault
; Writing to FCLCON1 register requires unlock sequence

mov #0xabcd, w10           ; Load first unlock key to w10 register
mov #0x4321, w11           ; Load second unlock key to w11 register
mov #0x0000, w0            ; Load desired value of FCLCON1 register in w0
mov w10, PWMKEY           ; Write first unlock key to PWMKEY register
mov w11, PWMKEY           ; Write second unlock key to PWMKEY register
mov w0, FCLCON1           ; Write desired value to FCLCON1 register

; Set PWM ownership and polarity using the IOCON1 register
; Writing to IOCON1 register requires unlock sequence

mov #0xabcd, w10           ; Load first unlock key to w10 register
mov #0x4321, w11           ; Load second unlock key to w11 register
mov #0xF000, w0            ; Load desired value of IOCON1 register in w0
mov w10, PWMKEY           ; Write first unlock key to PWMKEY register
mov w11, PWMKEY           ; Write second unlock key to PWMKEY register
mov w0, IOCON1            ; Write desired value to IOCON1 register
```

FIGURE 16-1: HIGH-SPEED PWMx MODULE ARCHITECTURAL OVERVIEW

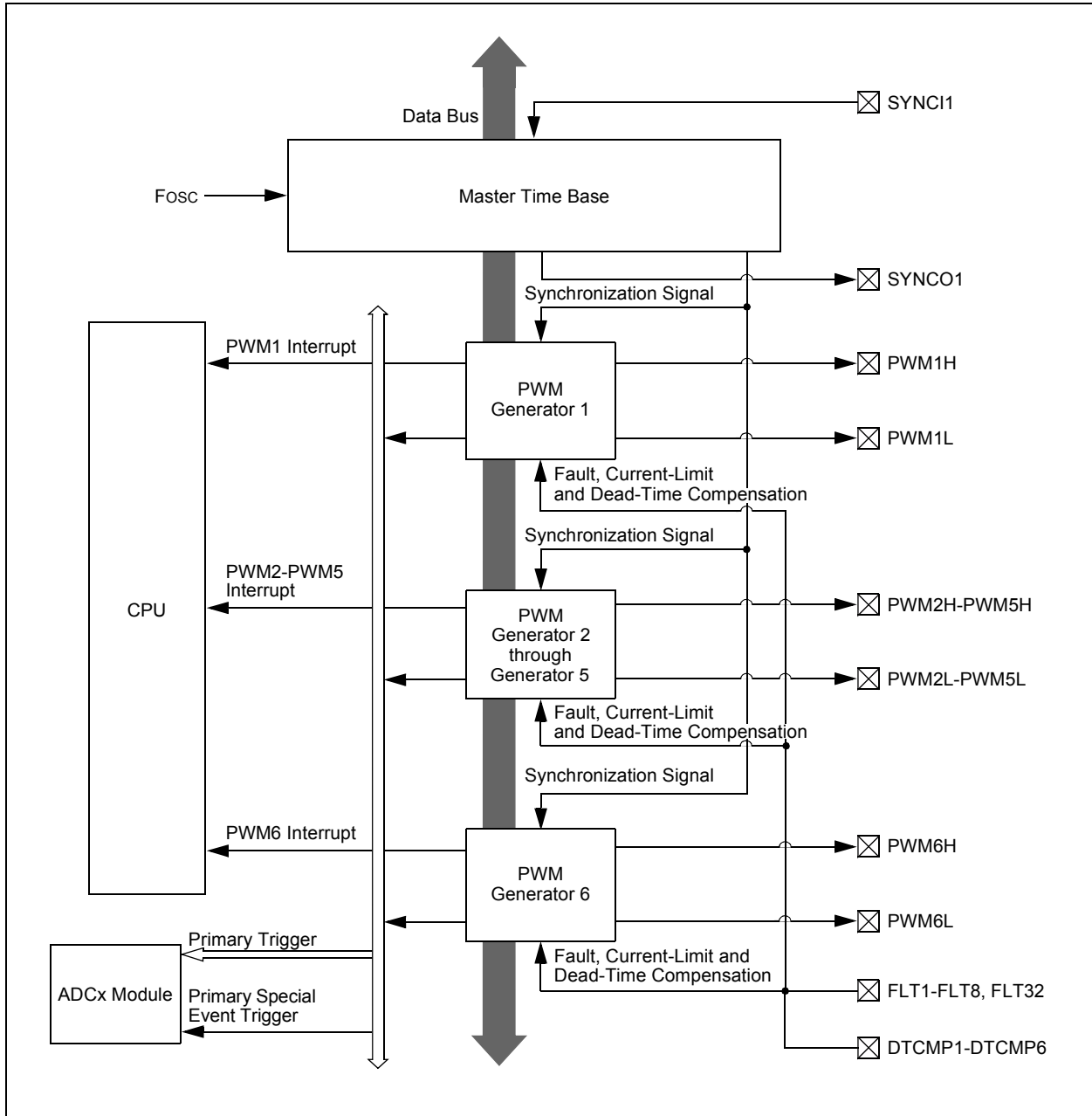
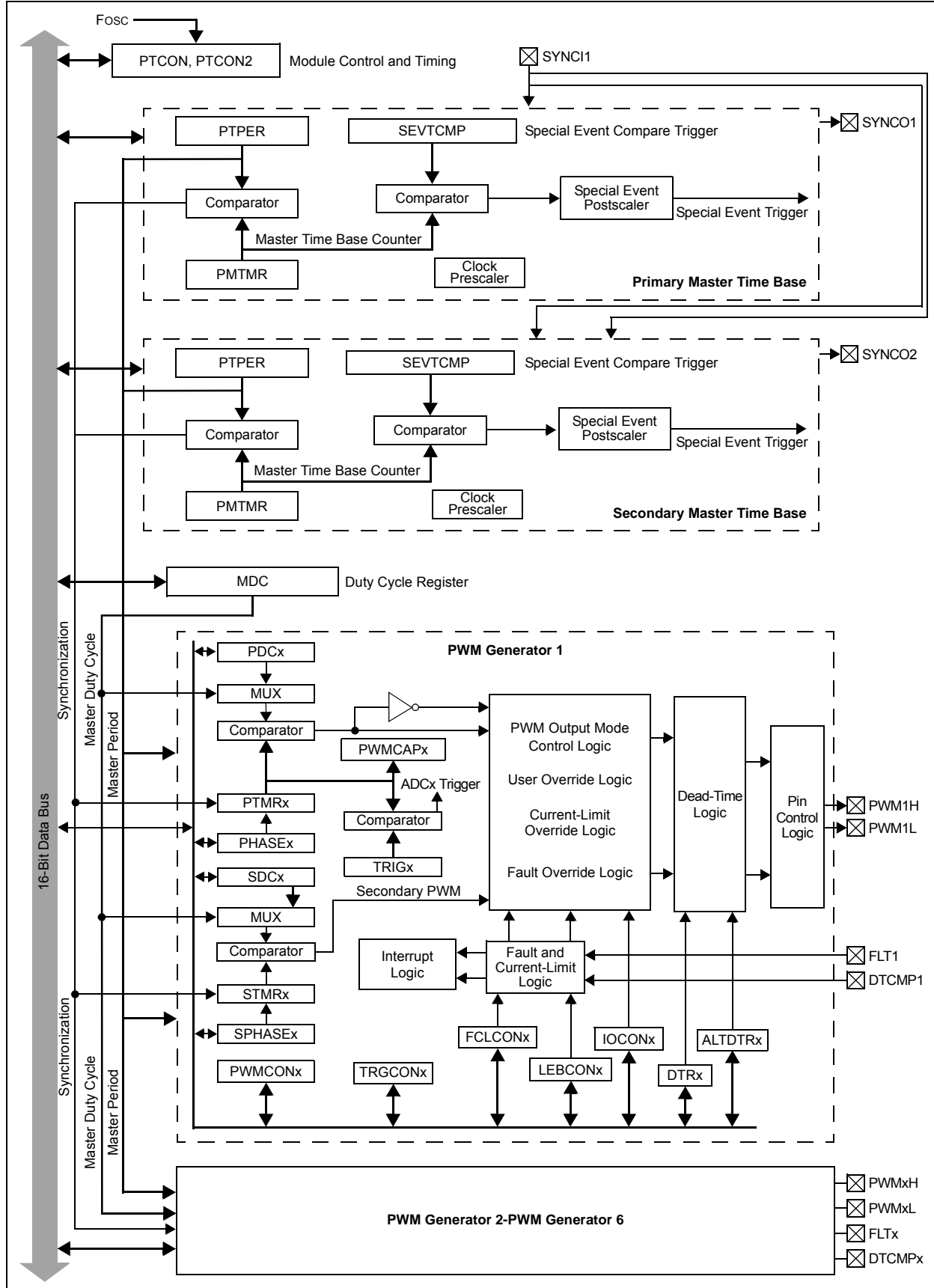

FIGURE 16-2: HIGH-SPEED PWMx MODULE REGISTER INTERCONNECTION DIAGRAM



16.2 PWMx Control Registers

REGISTER 16-1: PTCON: PWMx TIME BASE CONTROL REGISTER

R/W-0	U-0	R/W-0	HS/HC-0	R/W-0	R/W-0	R/W-0	R/W-0
PTEN	—	PTSIDL	SESTAT	SEIEN	EIPU ⁽¹⁾	SYNCPOL ⁽¹⁾	SYNCOEN ⁽¹⁾
bit 15							bit 8

R/W-0	R/W-0	R/W-0	R/W-0	R/W-0	R/W-0	R/W-0	R/W-0
SYNCEN ⁽¹⁾	SYNCSRC2 ⁽¹⁾	SYNCSRC1 ⁽¹⁾	SYNCSRC0 ⁽¹⁾	SEVTPS3 ⁽¹⁾	SEVTPS2 ⁽¹⁾	SEVTPS1 ⁽¹⁾	SEVTPS0 ⁽¹⁾
bit 7							bit 0

Legend:	HC = Hardware Clearable bit	HS = Hardware Settable bit
R = Readable bit	W = Writable bit	U = Unimplemented bit, read as '0'
-n = Value at POR	'1' = Bit is set	'0' = Bit is cleared x = Bit is unknown

- bit 15 **PTEN:** PWMx Module Enable bit
1 = PWMx module is enabled
0 = PWMx module is disabled
- bit 14 **Unimplemented:** Read as '0'
- bit 13 **PTSIDL:** PWMx Time Base Stop in Idle Mode bit
1 = PWMx time base halts in CPU Idle mode
0 = PWMx time base runs in CPU Idle mode
- bit 12 **SESTAT:** Special Event Interrupt Status bit
1 = Special event interrupt is pending
0 = Special event interrupt is not pending
- bit 11 **SEIEN:** Special Event Interrupt Enable bit
1 = Special event interrupt is enabled
0 = Special event interrupt is disabled
- bit 10 **EIPU:** Enable Immediate Period Updates bit⁽¹⁾
1 = Active Period register is updated immediately
0 = Active Period register updates occur on PWMx cycle boundaries
- bit 9 **SYNCPOL:** Synchronize Input and Output Polarity bit⁽¹⁾
1 = SYNCI1/SYNCO1 polarity is inverted (active-low)
0 = SYNCI1/SYNCO1 is active-high
- bit 8 **SYNCOEN:** Primary Time Base Sync Enable bit⁽¹⁾
1 = SYNCO1 output is enabled
0 = SYNCO1 output is disabled
- bit 7 **SYNCEN:** External Time Base Synchronization Enable bit⁽¹⁾
1 = External synchronization of primary time base is enabled
0 = External synchronization of primary time base is disabled

- Note 1:** These bits should be changed only when PTEN = 0. In addition, when using the SYNCI1 feature, the user application must program the Period register with a value that is slightly larger than the expected period of the external synchronization input signal.
- 2:** See [Section 25.0 “Peripheral Trigger Generator \(PTG\) Module”](#) for information on this selection.

REGISTER 16-1: PTCON: PWMx TIME BASE CONTROL REGISTER (CONTINUED)

bit 6-4 **SYNCSRC<2:0>**: Synchronous Source Selection bits⁽¹⁾

111 = Reserved

•
•
•

100 = Reserved

011 = PTGO17⁽²⁾

010 = PTGO16⁽²⁾

001 = Reserved

000 = SYNCI1

bit 3-0 **SEVTPS<3:0>**: PWMx Special Event Trigger Output Postscaler Select bits⁽¹⁾

1111 = 1:16 Postscaler generates Special Event Trigger on every sixteenth compare match event

•
•
•

0001 = 1:2 Postscaler generates Special Event Trigger on every second compare match event

0000 = 1:1 Postscaler generates Special Event Trigger on every compare match event

Note 1: These bits should be changed only when PTEN = 0. In addition, when using the SYNCI1 feature, the user application must program the Period register with a value that is slightly larger than the expected period of the external synchronization input signal.

2: See [Section 25.0 “Peripheral Trigger Generator \(PTG\) Module”](#) for information on this selection.

REGISTER 16-2: PTCON2: PWMx PRIMARY MASTER CLOCK DIVIDER SELECT REGISTER 2

U-0	U-0	U-0	U-0	U-0	U-0	U-0	U-0
—	—	—	—	—	—	—	—
bit 15							bit 8

U-0	U-0	U-0	U-0	U-0	R/W-0	R/W-0	R/W-0
—	—	—	—	—	PCLKDIV<2:0> ⁽¹⁾		
bit 7					bit 0		

Legend:			
R = Readable bit	W = Writable bit	U = Unimplemented bit, read as '0'	
-n = Value at POR	'1' = Bit is set	'0' = Bit is cleared	x = Bit is unknown

- bit 15-3 **Unimplemented:** Read as '0'
- bit 2-0 **PCLKDIV<2:0>:** PWMx Input Clock Prescaler (Divider) Select bits⁽¹⁾
 - 111 = Reserved
 - 110 = Divide-by-64
 - 101 = Divide-by-32
 - 100 = Divide-by-16
 - 011 = Divide-by-8
 - 010 = Divide-by-4
 - 001 = Divide-by-2
 - 000 = Divide-by-1, maximum PWMx timing resolution (power-on default)

Note 1: These bits should be changed only when PTEN = 0. Changing the clock selection during operation will yield unpredictable results.

dsPIC33EPXXXGM3XX/6XX/7XX

REGISTER 16-3: PTPER: PWMx PRIMARY MASTER TIME BASE PERIOD REGISTER

R/W-1	R/W-1	R/W-1	R/W-1	R/W-1	R/W-1	R/W-1	R/W-1
PTPER<15:8>							
bit 15				bit 8			

R/W-1	R/W-1	R/W-1	R/W-1	R/W-1	R/W-0	R/W-0	R/W-0
PTPER<7:0>							
bit 7				bit 0			

Legend:

R = Readable bit W = Writable bit U = Unimplemented bit, read as '0'
-n = Value at POR '1' = Bit is set '0' = Bit is cleared x = Bit is unknown

bit 15-0 **PTPER<15:0>**: Primary Master Time Base (PMTMR) Period Value bits

REGISTER 16-4: SEVTCMP: PWMx PRIMARY SPECIAL EVENT COMPARE REGISTER

R/W-0	R/W-0	R/W-0	R/W-0	R/W-0	R/W-0	R/W-0	R/W-0
SEVTCMP<15:8>							
bit 15				bit 8			

R/W-0	R/W-0	R/W-0	R/W-0	R/W-0	R/W-0	R/W-0	R/W-0
SEVTCMP<7:0>							
bit 7				bit 0			

Legend:

R = Readable bit W = Writable bit U = Unimplemented bit, read as '0'
-n = Value at POR '1' = Bit is set '0' = Bit is cleared x = Bit is unknown

bit 15-0 **SEVTCMP<15:0>**: Special Event Compare Count Value bits

REGISTER 16-5: STCON: PWMx SECONDARY TIME BASE CONTROL REGISTER

U-0	U-0	U-0	HS/HC-0	R/W-0	R/W-0	R/W-0	R/W-0
—	—	—	SESTAT	SEIEN	EIPU ⁽¹⁾	SYNCPOL ⁽¹⁾	SYNCOEN ⁽¹⁾
bit 15							bit 8

R/W-0	R/W-0	R/W-0	R/W-0	R/W-0	R/W-0	R/W-0	R/W-0
SYNCEN ⁽¹⁾	SYNCSRC2 ⁽¹⁾	SYNCSRC1 ⁽¹⁾	SYNCSRC0 ⁽¹⁾	SEVTPS3 ⁽¹⁾	SEVTPS2 ⁽¹⁾	SEVTPS1 ⁽¹⁾	SEVTPS0 ⁽¹⁾
bit 7							bit 0

Legend:	HC = Hardware Clearable bit	HS = Hardware Settable bit
R = Readable bit	W = Writable bit	U = Unimplemented bit, read as '0'
-n = Value at POR	'1' = Bit is set	'0' = Bit is cleared x = Bit is unknown

- bit 15-13 **Unimplemented:** Read as '0'
- bit 12 **SESTAT:** Special Event Interrupt Status bit
 - 1 = Special event interrupt is pending
 - 0 = Special event interrupt is not pending
- bit 11 **SEIEN:** Special Event Interrupt Enable bit
 - 1 = Special event interrupt is enabled
 - 0 = Special event interrupt is disabled
- bit 10 **EIPU:** Enable Immediate Period Updates bit⁽¹⁾
 - 1 = Active Period register is updated immediately
 - 0 = Active Period register updates occur on PWM cycle boundaries
- bit 9 **SYNCPOL:** Synchronize Input and Output Polarity bit⁽¹⁾
 - 1 = SYNCI2/SYNCO2 polarity is inverted (active-low)
 - 0 = SYNCI2/SYNCO2 is active-high
- bit 8 **SYNCOEN:** Primary Time Base Sync Enable bit⁽¹⁾
 - 1 = SYNCO2 output is enabled
 - 0 = SYNCO2 output is disabled
- bit 7 **SYNCEN:** External Time Base Synchronization Enable bit⁽¹⁾
 - 1 = External synchronization of primary time base is enabled
 - 0 = External synchronization of primary time base is disabled
- bit 6-4 **SYNCSRC<2:0>:** Synchronous Source Selection bits⁽¹⁾
 - 111 = Reserved
 -
 -
 -
 - 100 = Reserved
 - 011 = PTGO17⁽²⁾
 - 010 = PTGO16⁽²⁾
 - 001 = Reserved
 - 000 = SYNCI1

- Note 1:** These bits should be changed only when PTEN = 0. In addition, when using the SYNCI1 feature, the user application must program the Period register with a value that is slightly larger than the expected period of the external synchronization input signal.
- 2:** See [Section 25.0 “Peripheral Trigger Generator \(PTG\) Module”](#) for information on this selection.

REGISTER 16-5: STCON: PWMx SECONDARY TIME BASE CONTROL REGISTER (CONTINUED)

bit 3-0 **SEVTPS<3:0>**: PWMx Special Event Trigger Output Postscaler Select bits⁽¹⁾

- 1111 = 1:16 Postscaler generates the Special Event Trigger on every sixteenth compare match event
-
-
- 0001 = 1:2 Postscaler generates the Special Event Trigger on every second compare match event
- 0000 = 1:1 Postscaler generates the Special Event Trigger on every compare match event

Note 1: These bits should be changed only when PTEN = 0. In addition, when using the SYNC11 feature, the user application must program the Period register with a value that is slightly larger than the expected period of the external synchronization input signal.

2: See [Section 25.0 “Peripheral Trigger Generator \(PTG\) Module”](#) for information on this selection.

dsPIC33EPXXXGM3XX/6XX/7XX

REGISTER 16-6: STCON2: PWMx SECONDARY MASTER CLOCK DIVIDER SELECT REGISTER 2

U-0	U-0	U-0	U-0	U-0	U-0	U-0	U-0
—	—	—	—	—	—	—	—
bit 15							bit 8

U-0	U-0	U-0	U-0	U-0	R/W-0	R/W-0	R/W-0
—	—	—	—	—	PCLKDIV<2:0> ⁽¹⁾		
bit 7					bit 0		

Legend:

R = Readable bit

W = Writable bit

U = Unimplemented bit, read as '0'

-n = Value at POR

'1' = Bit is set

'0' = Bit is cleared

x = Bit is unknown

bit 15-3 **Unimplemented:** Read as '0'

bit 2-0 **PCLKDIV<2:0>:** PWMx Input Clock Prescaler (Divider) Select bits⁽¹⁾

111 = Reserved

110 = Divide-by-64

101 = Divide-by-32

100 = Divide-by-16

011 = Divide-by-8

010 = Divide-by-4

001 = Divide-by-2

000 = Divide-by-1, maximum PWMx timing resolution (power-on default)

Note 1: These bits should be changed only when PTEN = 0. Changing the clock selection during operation will yield unpredictable results.

dsPIC33EPXXXGM3XX/6XX/7XX

REGISTER 16-7: STPER: PWMx SECONDARY MASTER TIME BASE PERIOD REGISTER

R/W-1	R/W-1	R/W-1	R/W-1	R/W-1	R/W-1	R/W-1	R/W-1
STPER<15:8>							
bit 15							bit 8

R/W-1	R/W-1	R/W-1	R/W-1	R/W-1	R/W-0	R/W-0	R/W-0
STPER<7:0>							
bit 7							bit 0

Legend:

R = Readable bit W = Writable bit U = Unimplemented bit, read as '0'
-n = Value at POR '1' = Bit is set '0' = Bit is cleared x = Bit is unknown

bit 15-0 **STPER<15:0>**: PWMx Secondary Master Time Base (PMTMR) Period Value bits

REGISTER 16-8: SSEVTCMP: PWMx SECONDARY SPECIAL EVENT COMPARE REGISTER

R/W-0	R/W-0	R/W-0	R/W-0	R/W-0	R/W-0	R/W-0	R/W-0
SSEVTCMP<15:8>							
bit 15							bit 8

R/W-0	R/W-0	R/W-0	R/W-0	R/W-0	R/W-0	R/W-0	R/W-0
SSEVTCMP<7:0>							
bit 7							bit 0

Legend:

R = Readable bit W = Writable bit U = Unimplemented bit, read as '0'
-n = Value at POR '1' = Bit is set '0' = Bit is cleared x = Bit is unknown

bit 15-0 **SSEVTCMP<15:0>**: PWMx Secondary Special Event Compare Count Value bits

REGISTER 16-9: CHOP: PWMx CHOP CLOCK GENERATOR REGISTER

R/W-0	U-0	U-0	U-0	U-0	U-0	R/W-0	R/W-0
CHPCLKEN	—	—	—	—	—	CHOPCLK9	CHOPCLK8
bit 15						bit 8	

R/W-0	R/W-0	R/W-0	R/W-0	R/W-0	R/W-0	R/W-0	R/W-0
CHOPCLK7	CHOPCLK6	CHOPCLK5	CHOPCLK4	CHOPCLK3	CHOPCLK2	CHOPCLK1	CHOPCLK0
bit 7						bit 0	

Legend:

R = Readable bit	W = Writable bit	U = Unimplemented bit, read as '0'
-n = Value at POR	'1' = Bit is set	'0' = Bit is cleared x = Bit is unknown

- bit 15 **CHPCLKEN:** Enable Chop Clock Generator bit
 1 = Chop clock generator is enabled
 0 = Chop clock generator is disabled
- bit 14-10 **Unimplemented:** Read as '0'
- bit 9-0 **CHOPCLK<9:0>:** Chop Clock Divider bits
 The frequency of the chop clock signal is given by the following expression:
 Chop Frequency = (FP/PCLKDIV<2:0>)/(CHOP<9:0> + 1)

REGISTER 16-10: MDC: PWMx MASTER DUTY CYCLE REGISTER

R/W-0	R/W-0	R/W-0	R/W-0	R/W-0	R/W-0	R/W-0	R/W-0
MDC<15:8>							
bit 15						bit 8	

R/W-0	R/W-0	R/W-0	R/W-0	R/W-0	R/W-0	R/W-0	R/W-0
MDC<7:0>							
bit 7						bit 0	

Legend:

R = Readable bit	W = Writable bit	U = Unimplemented bit, read as '0'
-n = Value at POR	'1' = Bit is set	'0' = Bit is cleared x = Bit is unknown

- bit 15-0 **MDC<15:0>:** PWMx Master Duty Cycle Value bits

dsPIC33EPXXXGM3XX/6XX/7XX

REGISTER 16-11: PWMCONx: PWMx CONTROL REGISTER

HS/HC-0	HS/HC-0	HS/HC-0	R/W-0	R/W-0	R/W-0	R/W-0	R/W-0
FLTSTAT ⁽¹⁾	CLSTAT ⁽¹⁾	TRGSTAT	FLTIEN	CLIEN	TRGIEN	ITB ⁽²⁾	MDCS ⁽²⁾
bit 15						bit 8	

R/W-0	R/W-0	R/W-0	U-0	R/W-0	R/W-0	R/W-0	R/W-0
DTC1	DTC0	DTCP ⁽³⁾	—	MTBS	CAM ^(2,4)	XPRES ⁽⁵⁾	IUE ⁽²⁾
bit 7						bit 0	

Legend:	HC = Hardware Clearable bit	HS = Hardware Settable bit
R = Readable bit	W = Writable bit	U = Unimplemented bit, read as '0'
-n = Value at POR	'1' = Bit is set	'0' = Bit is cleared x = Bit is unknown

- bit 15 **FLTSTAT:** Fault Interrupt Status bit⁽¹⁾
 1 = Fault interrupt is pending
 0 = No Fault interrupt is pending
 This bit is cleared by setting: FLTIEN = 0.
- bit 14 **CLSTAT:** Current-Limit Interrupt Status bit⁽¹⁾
 1 = Current-limit interrupt is pending
 0 = No current-limit interrupt is pending
 This bit is cleared by setting: CLIEN = 0.
- bit 13 **TRGSTAT:** Trigger Interrupt Status bit
 1 = Trigger interrupt is pending
 0 = No trigger interrupt is pending
 This bit is cleared by setting: TRGIEN = 0.
- bit 12 **FLTIEN:** Fault Interrupt Enable bit
 1 = Fault interrupt is enabled
 0 = Fault interrupt is disabled and the FLTSTAT bit is cleared
- bit 11 **CLIEN:** Current-Limit Interrupt Enable bit
 1 = Current-limit interrupt is enabled
 0 = Current-limit interrupt is disabled and the CLSTAT bit is cleared
- bit 10 **TRGIEN:** Trigger Interrupt Enable bit
 1 = A trigger event generates an interrupt request
 0 = Trigger event interrupts are disabled and the TRGSTAT bit is cleared
- bit 9 **ITB:** Independent Time Base Mode bit⁽²⁾
 1 = PHASEx register provides the time base period for this PWMx generator
 0 = PTPER register provides timing for this PWMx generator
- bit 8 **MDCS:** Master Duty Cycle Register Select bit⁽²⁾
 1 = MDC register provides duty cycle information for this PWMx generator
 0 = PDCx register provides duty cycle information for this PWMx generator

- Note 1:** Software must clear the interrupt status here and in the corresponding IFSx bit in the interrupt controller.
- Note 2:** These bits should not be changed after the PWMx is enabled (PTEN = 1).
- Note 3:** DTC<1:0> = 11 for DTCP to be effective; otherwise, DTCP is ignored.
- Note 4:** The Independent Time Base (ITB = 1) mode must be enabled to use Center-Aligned mode. If ITB = 0, the CAM bit is ignored.
- Note 5:** To operate in External Period Reset mode, the ITB bit must be '1' and the CLMOD bit in the FCLCONx register must be '0'.

REGISTER 16-11: PWMCONx: PWMx CONTROL REGISTER (CONTINUED)

bit 7-6	DTC<1:0> : Dead-Time Control bits 11 = Dead-Time Compensation mode 10 = Dead-time function is disabled 01 = Negative dead time is actively applied for Complementary Output mode 00 = Positive dead time is actively applied for all Output modes
bit 5	DTCP : Dead-Time Compensation Polarity bit ⁽³⁾ <u>When Set to '1'</u> : If DTCMPx = 0, PWMxL is shortened and PWMxH is lengthened. If DTCMPx = 1, PWMxH is shortened and PWMxL is lengthened. <u>When Set to '0'</u> : If DTCMPx = 0, PWMxH is shortened and PWMxL is lengthened. If DTCMPx = 1, PWMxL is shortened and PWMxH is lengthened.
bit 4	Unimplemented : Read as '0'
bit 3	MTBS : Master Time Base Select bit 1 = PWMx generator uses the secondary master time base for synchronization and as the clock source for the PWMx generation logic (if secondary time base is available) 0 = PWMx generator uses the primary master time base for synchronization and as the clock source for the PWMx generation logic
bit 2	CAM : Center-Aligned Mode Enable bit ^(2,4) 1 = Center-Aligned mode is enabled 0 = Edge-Aligned mode is enabled
bit 1	XPRES : External PWMx Reset Control bit ⁽⁵⁾ 1 = Current-limit source resets the time base for this PWMx generator if it is in Independent Time Base mode 0 = External pins do not affect the PWMx time base
bit 0	IUE : Immediate Update Enable bit ⁽²⁾ 1 = Updates to the active MDC/PDCx/DTRx/ALTDTRx/PHASEx registers are immediate 0 = Updates to the active MDC/PDCx/DTRx/ALTDTRx/PHASEx registers are synchronized to the PWMx period boundary

- Note**
- 1: Software must clear the interrupt status here and in the corresponding IFSx bit in the interrupt controller.
 - 2: These bits should not be changed after the PWMx is enabled (PTEN = 1).
 - 3: DTC<1:0> = 11 for DTCP to be effective; otherwise, DTCP is ignored.
 - 4: The Independent Time Base (ITB = 1) mode must be enabled to use Center-Aligned mode. If ITB = 0, the CAM bit is ignored.
 - 5: To operate in External Period Reset mode, the ITB bit must be '1' and the CLMOD bit in the FCLCONx register must be '0'.

dsPIC33EPXXXGM3XX/6XX/7XX

REGISTER 16-12: PDCx: PWMx GENERATOR DUTY CYCLE REGISTER

R/W-0	R/W-0	R/W-0	R/W-0	R/W-0	R/W-0	R/W-0	R/W-0
PDCx<15:8>							
bit 15				bit 8			

R/W-0	R/W-0	R/W-0	R/W-0	R/W-0	R/W-0	R/W-0	R/W-0
PDCx<7:0>							
bit 7				bit 0			

Legend:

R = Readable bit W = Writable bit U = Unimplemented bit, read as '0'
 -n = Value at POR '1' = Bit is set '0' = Bit is cleared x = Bit is unknown

bit 15-0 **PDCx<15:0>**: PWMx Generator # Duty Cycle Value bits

REGISTER 16-13: SDCx: PWMx SECONDARY DUTY CYCLE REGISTER⁽¹⁾

R/W-0	R/W-0	R/W-0	R/W-0	R/W-0	R/W-0	R/W-0	R/W-0
SDCx<15:8>							
bit 15				bit 8			

R/W-0	R/W-0	R/W-0	R/W-0	R/W-0	R/W-0	R/W-0	R/W-0
SDCx<7:0>							
bit 7				bit 0			

Legend:

R = Readable bit W = Writable bit U = Unimplemented bit, read as '0'
 -n = Value at POR '1' = Bit is set '0' = Bit is cleared x = Bit is unknown

bit 15-0 **SDCx<15:0>**: Secondary Duty Cycle bits for PWMxL Output Pin bits

Note 1: The SDCx register is used in Independent PWM mode only. When used in Independent PWM mode, the SDCx register controls the PWMxL duty cycle.

REGISTER 16-14: PHASE_x: PWM_x PRIMARY PHASE-SHIFT REGISTER

R/W-0	R/W-0	R/W-0	R/W-0	R/W-0	R/W-0	R/W-0	R/W-0
PHASE _x <15:8>							
bit 15							bit 8

R/W-0	R/W-0	R/W-0	R/W-0	R/W-0	R/W-0	R/W-0	R/W-0
PHASE _x <7:0>							
bit 7							bit 0

Legend:			
R = Readable bit	W = Writable bit	U = Unimplemented bit, read as '0'	
-n = Value at POR	'1' = Bit is set	'0' = Bit is cleared	x = Bit is unknown

bit 15-0 **PHASE_x<15:0>**: Phase-Shift Value or Independent Time Base Period for the PWM_x Generator bits

Note 1: If ITB (PWMCON_x<9>) = 0, the following applies based on the mode of operation:
 Complementary, Redundant and Push-Pull Output mode (PMOD<1:0> (IOCON_x<11:10>) = 00, 01 or 10),
 PHASE_x<15:0> = Phase-shift value for PWM_xH and PWM_xL outputs.

2: If ITB (PWMCON_x<9>) = 1, the following applies based on the mode of operation:
 Complementary, Redundant and Push-Pull Output mode (PMOD<1:0> (IOCON_x<11:10>) = 00, 01 or 10),
 PHASE_x<15:0> = Independent Time Base Period Value for PWM_xH and PWM_xL.

REGISTER 16-15: SPHASE_x: PWM_x SECONDARY PHASE-SHIFT REGISTER^(1,2)

R/W-0	R/W-0	R/W-0	R/W-0	R/W-0	R/W-0	R/W-0	R/W-0
SPHASE _x <15:8>							
bit 15							bit 8

R/W-0	R/W-0	R/W-0	R/W-0	R/W-0	R/W-0	R/W-0	R/W-0
SPHASE _x <7:0>							
bit 7							bit 0

Legend:			
R = Readable bit	W = Writable bit	U = Unimplemented bit, read as '0'	
-n = Value at POR	'1' = Bit is set	'0' = Bit is cleared	x = Bit is unknown

bit 15-0 **SPHASE_x<15:0>**: Secondary Phase Offset for PWM_xL Output Pin bits
 (used in Independent PWM mode only)

Note 1: If ITB (PWMCON_x<9>) = 0, the following applies based on the mode of operation:

- Complementary, Redundant and Push-Pull Output mode (PMOD<1:0> (IOCON_x<11:10>) = 00, 01 or 10), SPHASE_x<15:0> = Not used.
- True Independent Output mode (PMOD<1:0> (IOCON_x<11:10>) = 11), SPHASE_x<15:0> = Phase-Shift Value for PWM_xL only.

2: If ITB (PWMCON_x<9>) = 1, the following applies based on the mode of operation:

- Complementary, Redundant and Push-Pull Output mode (PMOD<1:0> (IOCON_x<11:10>) = 00, 01 or 10), SPHASE_x<15:0> = Not used.
- True Independent Output mode (PMOD<1:0> (IOCON_x<11:10>) = 11), SPHASE_x<15:0> = Independent Time Base Period Value for PWM_xL only.

dsPIC33EPXXXGM3XX/6XX/7XX

REGISTER 16-16: DTRx: PWMx DEAD-TIME REGISTER

U-0	U-0	R/W-0	R/W-0	R/W-0	R/W-0	R/W-0	R/W-0
—	—	DTRx<13:8>					
bit 15							bit 8

R/W-0	R/W-0	R/W-0	R/W-0	R/W-0	R/W-0	R/W-0	R/W-0
DTRx<7:0>							
bit 7							bit 0

Legend:

R = Readable bit W = Writable bit U = Unimplemented bit, read as '0'
 -n = Value at POR '1' = Bit is set '0' = Bit is cleared x = Bit is unknown

bit 15-14 **Unimplemented:** Read as '0'
 bit 13-0 **DTRx<13:0>:** Unsigned 14-Bit Dead-Time Value for PWMx Dead-Time Unit bits

REGISTER 16-17: ALTDTRx: PWMx ALTERNATE DEAD-TIME REGISTER

U-0	U-0	R/W-0	R/W-0	R/W-0	R/W-0	R/W-0	R/W-0
—	—	ALTDTRx<13:8>					
bit 15							bit 8

R/W-0	R/W-0	R/W-0	R/W-0	R/W-0	R/W-0	R/W-0	R/W-0
ALTDTRx<7:0>							
bit 7							bit 0

Legend:

R = Readable bit W = Writable bit U = Unimplemented bit, read as '0'
 -n = Value at POR '1' = Bit is set '0' = Bit is cleared x = Bit is unknown

bit 15-14 **Unimplemented:** Read as '0'
 bit 13-0 **ALTDTRx<13:0>:** Unsigned 14-Bit Dead-Time Value for PWMx Dead-Time Unit bits

REGISTER 16-18: TRGCONx: PWMx TRIGGER CONTROL REGISTER

R/W-0	R/W-0	R/W-0	R/W-0	U-0	U-0	U-0	U-0
TRGDIV3	TRGDIV2	TRGDIV1	TRGDIV0	—	—	—	—
bit 15							bit 8

U-0	U-0	R/W-0	R/W-0	R/W-0	R/W-0	R/W-0	R/W-0
—	—	TRGSTR5 ⁽¹⁾	TRGSTR5 ⁽¹⁾	TRGSTR5 ⁽¹⁾	TRGSTR5 ⁽¹⁾	TRGSTR5 ⁽¹⁾	TRGSTR5 ⁽¹⁾
bit 7							bit 0

Legend:

R = Readable bit	W = Writable bit	U = Unimplemented bit, read as '0'
-n = Value at POR	'1' = Bit is set	'0' = Bit is cleared x = Bit is unknown

bit 15-12 **TRGDIV<3:0>**: Trigger # Output Divider bits

1111 = Trigger output for every 16th trigger event
 1110 = Trigger output for every 15th trigger event
 1101 = Trigger output for every 14th trigger event
 1100 = Trigger output for every 13th trigger event
 1011 = Trigger output for every 12th trigger event
 1010 = Trigger output for every 11th trigger event
 1001 = Trigger output for every 10th trigger event
 1000 = Trigger output for every 9th trigger event
 0111 = Trigger output for every 8th trigger event
 0110 = Trigger output for every 7th trigger event
 0101 = Trigger output for every 6th trigger event
 0100 = Trigger output for every 5th trigger event
 0011 = Trigger output for every 4th trigger event
 0010 = Trigger output for every 3rd trigger event
 0001 = Trigger output for every 2nd trigger event
 0000 = Trigger output for every trigger event

bit 11-6 **Unimplemented**: Read as '0'

bit 5-0 **TRGSTR<5:0>**: Trigger Postscaler Start Enable Select bits⁽¹⁾

111111 = Wait 63 PWM cycles before generating the first trigger event after the module is enabled
 •
 •
 •
 000010 = Wait 2 PWM cycles before generating the first trigger event after the module is enabled
 000001 = Wait 1 PWM cycle before generating the first trigger event after the module is enabled
 000000 = Wait 0 PWM cycles before generating the first trigger event after the module is enabled

Note 1: The secondary PWM generator cannot generate PWM trigger interrupts.

dsPIC33EPXXXGM3XX/6XX/7XX

REGISTER 16-19: IOCONx: PWMx I/O CONTROL REGISTER⁽²⁾

R/W-1	R/W-1	R/W-0	R/W-0	R/W-0	R/W-0	R/W-0	R/W-0
PENH	PENL	POLH	POLL	PMOD1 ⁽¹⁾	PMOD0 ⁽¹⁾	OVRENH	OVRENL
bit 15							bit 8

R/W-0	R/W-0	R/W-0	R/W-0	R/W-0	R/W-0	R/W-0	R/W-0
OVRDAT1	OVRDAT0	FLTDAT1	FLTDAT0	CLDAT1	CLDAT0	SWAP	OSYNC
bit 7							bit 0

Legend:

R = Readable bit	W = Writable bit	U = Unimplemented bit, read as '0'
-n = Value at POR	'1' = Bit is set	'0' = Bit is cleared
		x = Bit is unknown

- bit 15 **PENH:** PWMxH Output Pin Ownership bit
 1 = PWMx module controls the PWMxH pin
 0 = GPIO module controls the PWMxH pin
- bit 14 **PENL:** PWMxL Output Pin Ownership bit
 1 = PWMx module controls the PWMxL pin
 0 = GPIO module controls the PWMxL pin
- bit 13 **POLH:** PWMxH Output Pin Polarity bit
 1 = PWMxH pin is active-low
 0 = PWMxH pin is active-high
- bit 12 **POLL:** PWMxL Output Pin Polarity bit
 1 = PWMxL pin is active-low
 0 = PWMxL pin is active-high
- bit 11-10 **PMOD<1:0>:** PWMx # I/O Pin Mode bits⁽¹⁾
 11 = PWMx I/O pin pair is in the True Independent Output mode
 10 = PWMx I/O pin pair is in Push-Pull Output mode
 01 = PWMx I/O pin pair is in Redundant Output mode
 00 = PWMx I/O pin pair is in Complementary Output mode
- bit 9 **OVRENH:** Override Enable for PWMxH Pin bit
 1 = OVRDAT<1> controls the output on the PWMxH pin
 0 = PWMx generator controls the PWMxH pin
- bit 8 **OVRENL:** Override Enable for PWMxL Pin bit
 1 = OVRDAT<0> controls the output on the PWMxL pin
 0 = PWMx generator controls the PWMxL pin
- bit 7-6 **OVRDAT<1:0>:** Data for PWMxH, PWMxL Pins if Override is Enabled bits
 If OVERENH = 1, PWMxH is driven to the state specified by OVRDAT<1>.
 If OVERENL = 1, PWMxL is driven to the state specified by OVRDAT<0>.
- bit 5-4 **FLTDAT<1:0>:** Data for PWMxH and PWMxL Pins if FLTMOD is Enabled bits
 If Fault is active, PWMxH is driven to the state specified by FLTDAT<1>.
 If Fault is active, PWMxL is driven to the state specified by FLTDAT<0>.
- bit 3-2 **CLDAT<1:0>:** Data for PWMxH and PWMxL Pins if CLMOD is Enabled bits
 If current limit is active, PWMxH is driven to the state specified by CLDAT<1>.
 If current limit is active, PWMxL is driven to the state specified by CLDAT<0>.

Note 1: These bits should not be changed after the PWMx module is enabled (PTEN = 1).

Note 2: If the PWMLOCK Configuration bit (FOSCSEL<6>) is a '1', the IOCONx register can only be written after the unlock sequence has been executed.

REGISTER 16-19: IOCONx: PWMx I/O CONTROL REGISTER⁽²⁾ (CONTINUED)

- bit 1 **SWAP:** SWAP PWMxH and PWMxL Pins bit
 1 = PWMxH output signal is connected to the PWMxL pins; PWMxL output signal is connected to the PWMxH pins
 0 = PWMxH and PWMxL pins are mapped to their respective pins
- bit 0 **OSYNC:** Output Override Synchronization bit
 1 = Output overrides via the OVRDAT<1:0> bits are synchronized to the PWM time base
 0 = Output overrides via the OVDDAT<1:0> bits occur on the next CPU clock boundary

- Note 1:** These bits should not be changed after the PWMx module is enabled (PTEN = 1).
Note 2: If the PWMLOCK Configuration bit (FOSCSEL<6>) is a '1', the IOCONx register can only be written after the unlock sequence has been executed.

REGISTER 16-20: TRIGx: PWMx PRIMARY TRIGGER COMPARE VALUE REGISTER

R/W-0	R/W-0	R/W-0	R/W-0	R/W-0	R/W-0	R/W-0	R/W-0
TRGCMP<15:8>							
bit 15							bit 8

R/W-0	R/W-0	R/W-0	R/W-0	R/W-0	R/W-0	R/W-0	R/W-0
TRGCMP<7:0>							
bit 7							bit 0

Legend:			
R = Readable bit	W = Writable bit	U = Unimplemented bit, read as '0'	
-n = Value at POR	'1' = Bit is set	'0' = Bit is cleared	x = Bit is unknown

- bit 15-0 **TRGCMP<15:0>:** Trigger Control Value bits
 When the primary PWMx functions in the local time base, this register contains the compare values that can trigger the ADCx module.

dsPIC33EPXXXGM3XX/6XX/7XX

REGISTER 16-21: FCLCONx: PWMx FAULT CURRENT-LIMIT CONTROL REGISTER

R/W-0	R/W-0	R/W-0	R/W-0	R/W-0	R/W-0	R/W-0	R/W-0
IFLTMOD	CLSRC4	CLSRC3	CLSRC2	CLSRC1	CLSRC0	CLPOL ⁽¹⁾	CLMOD
bit 15						bit 8	

R/W-1	R/W-1	R/W-1	R/W-1	R/W-1	R/W-0	R/W-0	R/W-0
FLTSRC4	FLTSRC3	FLTSRC2	FLTSRC1	FLTSRC0	FLTPOL ⁽¹⁾	FLTMOD1	FLTMOD0
bit 7						bit 0	

Legend:

R = Readable bit W = Writable bit U = Unimplemented bit, read as '0'
 -n = Value at POR '1' = Bit is set '0' = Bit is cleared x = Bit is unknown

- bit 15 **IFLTMOD:** Independent Fault Mode Enable bit
 1 = Independent Fault mode is enabled
 0 = Independent Fault mode is disabled
- bit 14-10 **CLSRC<4:0>:** Current-Limit Control Signal Source Select for the PWMx Generator # bits
 11111 = Fault 32
 11110 = Reserved
 •
 •
 •
 01100 = Op Amp/Comparator 5
 01011 = Comparator 4
 01010 = Op Amp/Comparator 3
 01001 = Op Amp/Comparator 2
 01000 = Op Amp/Comparator 1
 00111 = Fault 8
 00110 = Fault 7
 00101 = Fault 6
 00100 = Fault 5
 00011 = Fault 4
 00010 = Fault 3
 00001 = Fault 2
 00000 = Fault 1
- bit 9 **CLPOL:** Current-Limit Polarity for PWMx Generator # bit⁽¹⁾
 1 = The selected current-limit source is active-low
 0 = The selected current-limit source is active-high
- bit 8 **CLMOD:** Current-Limit Mode Enable for PWMx Generator # bit
 1 = Current-Limit mode is enabled
 0 = Current-Limit mode is disabled

Note 1: These bits should be changed only when PTEN = 0. Changing the clock selection during operation will yield unpredictable results.

REGISTER 16-21: FCLCONx: PWMx FAULT CURRENT-LIMIT CONTROL REGISTER (CONTINUED)

bit 7-3	FLTSRC<4:0> : Fault Control Signal Source Select for PWMx Generator # bits 11111 = Fault 32 (default) 11110 = Reserved • • • 01100 = Op Amp/Comparator 5 01011 = Comparator 4 01010 = Op Amp/Comparator 3 01001 = Op Amp/Comparator 2 01000 = Op Amp/Comparator 1 00111 = Fault 8 00110 = Fault 7 00101 = Fault 6 00100 = Fault 5 00011 = Fault 4 00010 = Fault 3 00001 = Fault 2 00000 = Fault 1
bit 2	FLTPOL : Fault Polarity for PWMx Generator # bit ⁽¹⁾ 1 = The selected Fault source is active-low 0 = The selected Fault source is active-high
bit 1-0	FLTMOD<1:0> : Fault Mode for PWMx Generator # bits 11 = Fault input is disabled 10 = Reserved 01 = The selected Fault source forces the PWMxH, PWMxL pins to FLTDATx values (cycle) 00 = The selected Fault source forces the PWMxH, PWMxL pins to FLTDATx values (latched condition)

Note 1: These bits should be changed only when PTEN = 0. Changing the clock selection during operation will yield unpredictable results.

dsPIC33EPXXXGM3XX/6XX/7XX

REGISTER 16-22: LEBCONx: LEADING-EDGE BLANKING CONTROL REGISTER x

R/W-0	R/W-0	R/W-0	R/W-0	R/W-0	R/W-0	U-0	U-0
PHR	PHF	PLR	PLF	FLTLEBEN	CLLEBEN	—	—
bit 15						bit 8	

U-0	U-0	R/W-0	R/W-0	R/W-0	R/W-0	R/W-0	R/W-0
—	—	BCH ⁽¹⁾	BCL ⁽¹⁾	BPHH	BPHL	BPLH	BPLL
bit 7						bit 0	

Legend:

R = Readable bit W = Writable bit U = Unimplemented bit, read as '0'
 -n = Value at POR '1' = Bit is set '0' = Bit is cleared x = Bit is unknown

- bit 15 **PHR:** PWMxH Rising Edge Trigger Enable bit
 1 = Rising edge of PWMxH will trigger the Leading-Edge Blanking counter
 0 = Leading-Edge Blanking ignores the rising edge of PWMxH
- bit 14 **PHF:** PWMxH Falling Edge Trigger Enable bit
 1 = Falling edge of PWMxH will trigger the Leading-Edge Blanking counter
 0 = Leading-Edge Blanking ignores the falling edge of PWMxH
- bit 13 **PLR:** PWMxL Rising Edge Trigger Enable bit
 1 = Rising edge of PWMxL will trigger the Leading-Edge Blanking counter
 0 = Leading-Edge Blanking ignores the rising edge of PWMxL
- bit 12 **PLF:** PWMxL Falling Edge Trigger Enable bit
 1 = Falling edge of PWMxL will trigger the Leading-Edge Blanking counter
 0 = Leading-Edge Blanking ignores the falling edge of PWMxL
- bit 11 **FLTLEBEN:** Fault Input Leading-Edge Blanking Enable bit
 1 = Leading-Edge Blanking is applied to the selected Fault input
 0 = Leading-Edge Blanking is not applied to the selected Fault input
- bit 10 **CLLEBEN:** Current-Limit Leading-Edge Blanking Enable bit
 1 = Leading-Edge Blanking is applied to the selected current-limit input
 0 = Leading-Edge Blanking is not applied to the selected current-limit input
- bit 9-6 **Unimplemented:** Read as '0'
- bit 5 **BCH:** Blanking in Selected Blanking Signal High Enable bit⁽¹⁾
 1 = State blanking (of current-limit and/or Fault input signals) when selected blanking signal is high
 0 = No blanking when selected blanking signal is high
- bit 4 **BCL:** Blanking in Selected Blanking Signal Low Enable bit⁽¹⁾
 1 = State blanking (of current-limit and/or Fault input signals) when selected blanking signal is low
 0 = No blanking when selected blanking signal is low
- bit 3 **BPHH:** Blanking in PWMxH High Enable bit
 1 = State blanking (of current-limit and/or Fault input signals) when PWMxH output is high
 0 = No blanking when PWMxH output is high
- bit 2 **BPHL:** Blanking in PWMxH Low Enable bit
 1 = State blanking (of current-limit and/or Fault input signals) when PWMxH output is low
 0 = No blanking when PWMxH output is low
- bit 1 **BPLH:** Blanking in PWMxL High Enable bit
 1 = State blanking (of current-limit and/or Fault input signals) when PWMxL output is high
 0 = No blanking when PWMxL output is high
- bit 0 **BPLL:** Blanking in PWMxL Low Enable bit
 1 = State blanking (of current-limit and/or Fault input signals) when PWMxL output is low
 0 = No blanking when PWMxL output is low

Note 1: The blanking signal is selected via the BLANKSELx bits in the AUXCONx register.

dsPIC33EPXXXGM3XX/6XX/7XX

REGISTER 16-23: LEBDLYx: LEADING-EDGE BLANKING DELAY REGISTER x

U-0	U-0	U-0	U-0	R/W-0	R/W-0	R/W-0	R/W-0
—	—	—	—	LEB<11:8>			
bit 15				bit 8			

R/W-0	R/W-0	R/W-0	R/W-0	R/W-0	R/W-0	R/W-0	R/W-0
LEB<7:0>							
bit 7				bit 0			

Legend:

R = Readable bit

W = Writable bit

U = Unimplemented bit, read as '0'

-n = Value at POR

'1' = Bit is set

'0' = Bit is cleared

x = Bit is unknown

bit 15-12 **Unimplemented:** Read as '0'

bit 11-0 **LEB<11:0>:** Leading-Edge Blanking Delay for Current-Limit and Fault Inputs bits

dsPIC33EPXXXGM3XX/6XX/7XX

REGISTER 16-24: AUXCONx: PWMx AUXILIARY CONTROL REGISTER

U-0	U-0	U-0	U-0	R/W-0	R/W-0	R/W-0	R/W-0
—	—	—	—	BLANKSEL3	BLANKSEL2	BLANKSEL1	BLANKSEL0
bit 15				bit 8			

U-0	U-0	R/W-0	R/W-0	R/W-0	R/W-0	R/W-0	R/W-0
—	—	CHOPSEL3	CHOPSEL2	CHOPSEL1	CHOPSEL0	CHOPHEN	CHOPLEN
bit 7		bit 0					

Legend:

R = Readable bit W = Writable bit U = Unimplemented bit, read as '0'
 -n = Value at POR '1' = Bit is set '0' = Bit is cleared x = Bit is unknown

- bit 15-12 **Unimplemented:** Read as '0'
- bit 11-8 **BLANKSEL<3:0>:** PWMx State Blank Source Select bits
 The selected state blank signal will block the current-limit and/or Fault input signals (if enabled via the BCH and BCL bits in the LEBCONx register).
 1001 = Reserved
 •
 •
 •
 0110 = PWM6H is selected as state blank source
 0101 = PWM5H is selected as state blank source
 0100 = PWM4H is selected as state blank source
 0011 = PWM3H is selected as state blank source
 0010 = PWM2H is selected as state blank source
 0001 = PWM1H is selected as state blank source
 0000 = No state blanking
- bit 7-6 **Unimplemented:** Read as '0'
- bit 5-2 **CHOPSEL<3:0>:** PWMx Chop Clock Source Select bits
 The selected signal will enable and disable (CHOP) the selected PWMx outputs.
 1001 = Reserved
 •
 •
 •
 0110 = PWM6H is selected as state blank source
 0101 = PWM5H is selected as state blank source
 0100 = PWM4H is selected as state blank source
 0011 = PWM3H is selected as CHOP clock source
 0010 = PWM2H is selected as CHOP clock source
 0001 = PWM1H is selected as CHOP clock source
 0000 = Chop clock generator is selected as CHOP clock source
- bit 1 **CHOPHEN:** PWMxH Output Chopping Enable bit
 1 = PWMxH chopping function is enabled
 0 = PWMxH chopping function is disabled
- bit 0 **CHOPLEN:** PWMxL Output Chopping Enable bit
 1 = PWMxL chopping function is enabled
 0 = PWMxL chopping function is disabled

REGISTER 16-25: PWMCAPx: PWMx PRIMARY TIME BASE CAPTURE REGISTER

R-0	R-0	R-0	R-0	R-0	R-0	R-0	R-0
PWMCAPx<15:8> ^(1,2)							
bit 15				bit 8			

R-0	R-0	R-0	R-0	R-0	R-0	R-0	R-0
PWMCAPx<7:0> ^(1,2)							
bit 7				bit 0			

Legend:			
R = Readable bit	W = Writable bit	U = Unimplemented bit, read as '0'	
-n = Value at POR	'1' = Bit is set	'0' = Bit is cleared	x = Bit is unknown

bit 15-0 **PWMCAPx<15:0>**: PWMx Captured Time Base Value bits^(1,2)
 The value in this register represents the captured PWMx time base value when a leading edge is detected on the current-limit input.

- Note 1:** The capture feature is only available on a primary output (PWMxH).
2: This feature is active only after LEB processing on the current-limit input signal is complete.

dsPIC33EPXXGM3XX/6XX/7XX

NOTES:

17.0 QUADRATURE ENCODER INTERFACE (QEI) MODULE

Note 1: This data sheet summarizes the features of the dsPIC33EPXXXGM3XX/6XX/7XX family of devices. It is not intended to be a comprehensive reference source. To complement the information in this data sheet, refer to the “*dsPIC33/PIC24 Family Reference Manual*”, “**Quadrature Encoder Interface (QEI)**” (DS70601) which is available from the Microchip web site (www.microchip.com).

2: Some registers and associated bits described in this section may not be available on all devices. Refer to **Section 4.0 “Memory Organization”** in this data sheet for device-specific register and bit information.

This chapter describes the Quadrature Encoder Interface (QEI) module and associated operational modes. The QEI module provides the interface to incremental encoders for obtaining mechanical position data.

The operational features of the QEI module include:

- 32-Bit Position Counter
- 32-Bit Index Pulse Counter
- 32-Bit Interval Timer
- 16-Bit Velocity Counter
- 32-Bit Position Initialization/Capture/Compare High Register
- 32-Bit Position Compare Low Register
- x4 Quadrature Count mode
- External Up/Down Count mode
- External Gated Count mode
- External Gated Timer mode
- Internal Timer mode

[Figure 17-1](#) illustrates the QEIx block diagram.

FIGURE 17-1: QEix BLOCK DIAGRAM

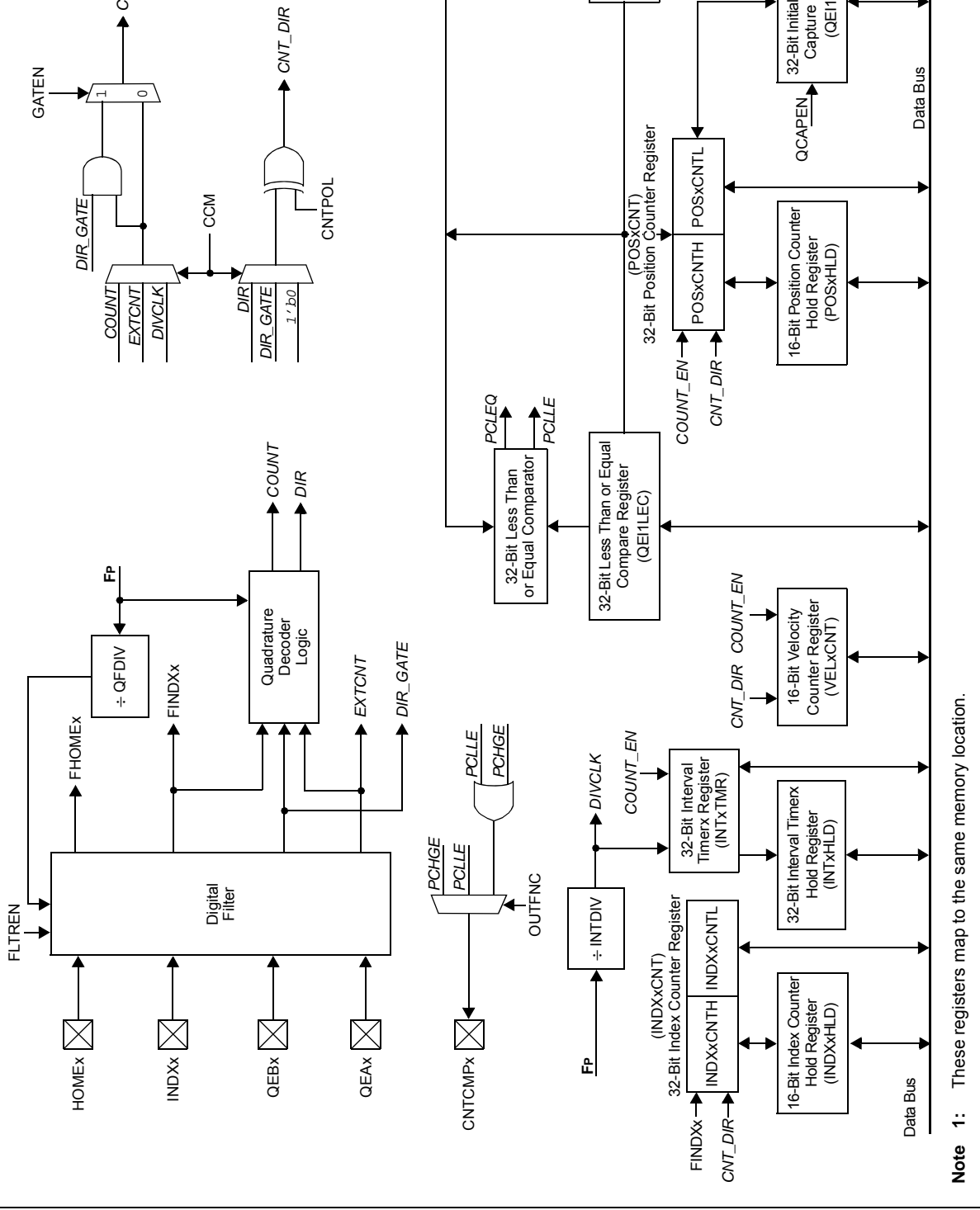

Note 1: These registers map to the same memory location.

17.1 QEI Control Registers

REGISTER 17-1: QEIXCON: QEIX CONTROL REGISTER

R/W-0	U-0	R/W-0	R/W-0	R/W-0	R/W-0	R/W-0	R/W-0
QEIEN	—	QEISIDL	PIMOD2 ⁽¹⁾	PIMOD1 ⁽¹⁾	PIMOD0 ⁽¹⁾	IMV1 ^(2,4)	IMV0 ^(2,4)
bit 15							bit 8

U-0	R/W-0	R/W-0	R/W-0	R/W-0	R/W-0	R/W-0	R/W-0
—	INTDIV2 ⁽³⁾	INTDIV1 ⁽³⁾	INTDIV0 ⁽³⁾	CNTPOL	GATEN	CCM1	CCM0
bit 7							bit 0

Legend:

R = Readable bit	W = Writable bit	U = Unimplemented bit, read as '0'
-n = Value at POR	'1' = Bit is set	'0' = Bit is cleared x = Bit is unknown

- bit 15 **QEIEN:** QEIX Module Counter Enable bit
 1 = Module counters are enabled
 0 = Module counters are disabled, but SFRs can be read or written to
- bit 14 **Unimplemented:** Read as '0'
- bit 13 **QEISIDL:** QEIX Stop in Idle Mode bit
 1 = Discontinues module operation when device enters Idle mode
 0 = Continues module operation in Idle mode
- bit 12-10 **PIMOD<2:0>:** Position Counter Initialization Mode Select bits⁽¹⁾
 111 = Reserved
 110 = Modulo Count mode for position counter
 101 = Resets the position counter when the position counter equals the QEIXGEC register
 100 = Second index event after home event initializes the position counter with contents of the QEIXIC register
 011 = First index event after home event initializes the position counter with contents of the QEIXIC register
 010 = Next index input event initializes the position counter with contents of the QEIXIC register
 001 = Every index input event resets the position counter
 000 = Index input event does not affect position counter
- bit 9-8 **IMV<1:0>:** Index Match Value bits^(2,4)
 1 = Required state of Phase B input signal for match on index pulse
 0 = Required state of Phase A input signal for match on index pulse
- bit 7 **Unimplemented:** Read as '0'

- Note 1:** When CCM<1:0> = 10 or CCM<1:0> = 11, all of the QEI counters operate as timers and the PIMOD<2:0> bits are ignored.
- 2:** When CCM<1:0> = 00, and QEAX and QEBX values match the Index Match Value (IMV), the POSCNTNTH and POSCNTL registers are reset.
- 3:** The selected clock rate should be at least twice the expected maximum quadrature count rate.
- 4:** The match value applies to the A and B inputs after the swap and polarity bits have been applied.

dsPIC33EPXXXGM3XX/6XX/7XX

REGISTER 17-1: QEIXCON: QEIX CONTROL REGISTER (CONTINUED)

- bit 6-4 **INTDIV<2:0>**: Timer Input Clock Prescale Select bits (interval timer, main timer (position counter), velocity counter and index counter internal clock divider select)⁽³⁾
- 111 = 1:128 prescale value
 - 110 = 1:64 prescale value
 - 101 = 1:32 prescale value
 - 100 = 1:16 prescale value
 - 011 = 1:8 prescale value
 - 010 = 1:4 prescale value
 - 001 = 1:2 prescale value
 - 000 = 1:1 prescale value
- bit 3 **CNTPOL**: Position and Index Counter/Timer Direction Select bit
- 1 = Counter direction is negative unless modified by external up/down signal
 - 0 = Counter direction is positive unless modified by external up/down signal
- bit 2 **GATEN**: External Count Gate Enable bit
- 1 = External gate signal controls position counter operation
 - 0 = External gate signal does not affect position counter/timer operation
- bit 1-0 **CCM<1:0>**: Counter Control Mode Selection bits
- 11 = Internal Timer mode with optional external count is selected
 - 10 = External clock count with optional external count is selected
 - 01 = External clock count with external up/down direction is selected
 - 00 = Quadrature Encoder Interface (x4 mode) Count mode is selected

- Note 1:** When CCM<1:0> = 10 or CCM<1:0> = 11, all of the QEI counters operate as timers and the PIMOD<2:0> bits are ignored.
- 2:** When CCM<1:0> = 00, and QEAX and QEBX values match the Index Match Value (IMV), the POSCNTNTH and POSCNTL registers are reset.
- 3:** The selected clock rate should be at least twice the expected maximum quadrature count rate.
- 4:** The match value applies to the A and B inputs after the swap and polarity bits have been applied.

dsPIC33EPXXXGM3XX/6XX/7XX

REGISTER 17-2: QEIXIOC: QEIX I/O CONTROL REGISTER

R/W-0	R/W-0	R/W-0	R/W-0	R/W-0	R/W-0	R/W-0	R/W-0
QCAPEN	FLTREN	QFDIV2	QFDIV1	QFDIV0	OUTFNC1	OUTFNC0	SWPAB
bit 15							bit 8

R/W-0	R/W-0	R/W-0	R/W-0	R-x	R-x	R-x	R-x
HOMPOL	IDXPOL	QEBPOL	QEAPOL	HOME	INDEX	QEB	QEA
bit 7							bit 0

Legend:

R = Readable bit W = Writable bit U = Unimplemented bit, read as '0'
 -n = Value at POR '1' = Bit is set '0' = Bit is cleared x = Bit is unknown

- bit 15 **QCAPEN:** QEIX Position Counter Input Capture Enable bit
 1 = Index match event of home input triggers a position capture event
 0 = Index match event (positive edge) does not trigger a position capture event
- bit 14 **FLTREN:** QEAX/QEBX/INDXx/HOMEx Digital Filter Enable bit
 1 = Input pin digital filter is enabled
 0 = Input pin digital filter is disabled (bypassed)
- bit 13-11 **QFDIV<2:0>:** QEAX/QEBX/INDXx/HOMEx Digital Input Filter Clock Divide Select bits
 111 = 1:128 clock divide
 110 = 1:64 clock divide
 101 = 1:32 clock divide
 100 = 1:16 clock divide
 011 = 1:8 clock divide
 010 = 1:4 clock divide
 001 = 1:2 clock divide
 000 = 1:1 clock divide
- bit 10-9 **OUTFNC<1:0>:** QEIX Module Output Function Mode Select bits
 11 = The CNTCMPx pin goes high when $QEIXLEC \geq POSxCNT \geq QEIXGEC$
 10 = The CNTCMPx pin goes high when $POSxCNT \leq QEIXLEC$
 01 = The CNTCMPx pin goes high when $POSxCNT \geq QEIXGEC$
 00 = Output is disabled
- bit 8 **SWPAB:** Swap QEAX and QEBX Inputs bit
 1 = QEAX and QEBX are swapped prior to quadrature decoder logic
 0 = QEAX and QEBX are not swapped
- bit 7 **HOMPOL:** HOMEx Input Polarity Select bit
 1 = Input is inverted
 0 = Input is not inverted
- bit 6 **IDXPOL:** INDXx Input Polarity Select bit
 1 = Input is inverted
 0 = Input is not inverted
- bit 5 **QEBPOL:** QEBx Input Polarity Select bit
 1 = Input is inverted
 0 = Input is not inverted
- bit 4 **QEAPOL:** QEAX Input Polarity Select bit
 1 = Input is inverted
 0 = Input is not inverted
- bit 3 **HOME:** Status of HOMEx Input Pin After Polarity Control bit
 1 = Pin is at logic '1'
 0 = Pin is at logic '0'

REGISTER 17-2: QEIXIOC: QEIX I/O CONTROL REGISTER (CONTINUED)

- bit 2 **INDEX:** Status of INDXx Input Pin After Polarity Control bit
 1 = Pin is at logic '1'
 0 = Pin is at logic '0'
- bit 1 **QEB:** Status of QEBx Input Pin After Polarity Control and SWPAB Pin Swapping bit
 1 = Pin is at logic '1'
 0 = Pin is at logic '0'
- bit 0 **QEA:** Status of QEAx Input Pin After Polarity Control and SWPAB Pin Swapping bit
 1 = Pin is at logic '1'
 0 = Pin is at logic '0'

REGISTER 17-3: QEIXSTAT: QEIX STATUS REGISTER

U-0	U-0	HS, R/C-0	R/W-0	HS, R/C-0	R/W-0	HS, R/C-0	R/W-0
—	—	PCHEQIRQ	PCHEQIEN	PCLEQIRQ	PCLEQIEN	POSOVIRQ	POSOVIEN
bit 15							bit 8

HS, R/C-0	R/W-0	HS, R/C-0	R/W-0	HS, R/C-0	R/W-0	HS, R/C-0	R/W-0
PCIIIRQ ⁽¹⁾	PCIIEN	VELOVIRQ	VELOVIEN	HOMIRQ	HOMIEN	IDXIRQ	IDXIEN
bit 7							bit 0

Legend:	HS = Hardware Settable bit	C = Clearable bit
R = Readable bit	W = Writable bit	U = Unimplemented bit, read as '0'
-n = Value at POR	'1' = Bit is set	'0' = Bit is cleared
		x = Bit is unknown

- bit 15-14 **Unimplemented:** Read as '0'
- bit 13 **PCHEQIRQ:** Position Counter Greater Than or Equal Compare Status bit
 1 = POSxCNT ≥ QEIXGEC
 0 = POSxCNT < QEIXGEC
- bit 12 **PCHEQIEN:** Position Counter Greater Than or Equal Compare Interrupt Enable bit
 1 = Interrupt is enabled
 0 = Interrupt is disabled
- bit 11 **PCLEQIRQ:** Position Counter Less Than or Equal Compare Status bit
 1 = POSxCNT ≤ QEIXLEC
 0 = POSxCNT > QEIXLEC
- bit 10 **PCLEQIEN:** Position Counter Less Than or Equal Compare Interrupt Enable bit
 1 = Interrupt is enabled
 0 = Interrupt is disabled
- bit 9 **POSOVIRQ:** Position Counter Overflow Status bit
 1 = Overflow has occurred
 0 = No overflow has occurred
- bit 8 **POSOVIEN:** Position Counter Overflow Interrupt Enable bit
 1 = Interrupt is enabled
 0 = Interrupt is disabled
- bit 7 **PCIIIRQ:** Position Counter (Homing) Initialization Process Complete Status bit⁽¹⁾
 1 = POSxCNT was reinitialized
 0 = POSxCNT was not reinitialized
- bit 6 **PCIIEN:** Position Counter (Homing) Initialization Process Complete interrupt Enable bit
 1 = Interrupt is enabled
 0 = Interrupt is disabled
- bit 5 **VELOVIRQ:** Velocity Counter Overflow Status bit
 1 = Overflow has occurred
 0 = No overflow has occurred
- bit 4 **VELOVIEN:** Velocity Counter Overflow Interrupt Enable bit
 1 = Interrupt is enabled
 0 = Interrupt is disabled
- bit 3 **HOMIRQ:** Status Flag for Home Event Status bit
 1 = Home event has occurred
 0 = No home event has occurred

Note 1: This status bit is only applicable to PIMOD<2:0> = 011 and 100 modes.

dsPIC33EPXXXGM3XX/6XX/7XX

REGISTER 17-3: QEIxSTAT: QEIx STATUS REGISTER (CONTINUED)

- bit 2 **HOMIEN:** Home Input Event Interrupt Enable bit
 1 = Interrupt is enabled
 0 = Interrupt is disabled
- bit 1 **IDXIRQ:** Status Flag for Index Event Status bit
 1 = Index event has occurred
 0 = No index event has occurred
- bit 0 **IDXIEN:** Index Input Event Interrupt Enable bit
 1 = Interrupt is enabled
 0 = Interrupt is disabled

Note 1: This status bit is only applicable to PIMOD<2:0> = 011 and 100 modes.

dsPIC33EPXXXGM3XX/6XX/7XX

REGISTER 17-4: POSxCNTH: POSITION COUNTER x HIGH WORD REGISTER

R/W-0	R/W-0	R/W-0	R/W-0	R/W-0	R/W-0	R/W-0	R/W-0
POSCNT<31:24>							
bit 15							bit 8

R/W-0	R/W-0	R/W-0	R/W-0	R/W-0	R/W-0	R/W-0	R/W-0
POSCNT<23:16>							
bit 7							bit 0

Legend:

R = Readable bit	W = Writable bit	U = Unimplemented bit, read as '0'
-n = Value at POR	'1' = Bit is set	'0' = Bit is cleared x = Bit is unknown

bit 15-0 **POSCNT<31:16>**: High Word Used to Form 32-Bit Position Counter x Register (POSxCNT) bits

REGISTER 17-5: POSxCNTL: POSITION COUNTER x LOW WORD REGISTER

R/W-0	R/W-0	R/W-0	R/W-0	R/W-0	R/W-0	R/W-0	R/W-0
POSCNT<15:8>							
bit 15							bit 8

R/W-0	R/W-0	R/W-0	R/W-0	R/W-0	R/W-0	R/W-0	R/W-0
POSCNT<7:0>							
bit 7							bit 0

Legend:

R = Readable bit	W = Writable bit	U = Unimplemented bit, read as '0'
-n = Value at POR	'1' = Bit is set	'0' = Bit is cleared x = Bit is unknown

bit 15-0 **POSCNT<15:0>**: Low Word Used to Form 32-Bit Position Counter x Register (POSxCNT) bits

dsPIC33EPXXXGM3XX/6XX/7XX

REGISTER 17-6: POSxHLD: POSITION COUNTER x HOLD REGISTER

R/W-0	R/W-0	R/W-0	R/W-0	R/W-0	R/W-0	R/W-0	R/W-0
POSHLD<15:8>							
bit 15							bit 8

R/W-0	R/W-0	R/W-0	R/W-0	R/W-0	R/W-0	R/W-0	R/W-0
POSHLD<7:0>							
bit 7							bit 0

Legend:

R = Readable bit W = Writable bit U = Unimplemented bit, read as '0'
-n = Value at POR '1' = Bit is set '0' = Bit is cleared x = Bit is unknown

bit 15-0 **POSHLD<15:0>**: Holding Register for Reading and Writing POSxCNT bits

REGISTER 17-7: VELxCNT: VELOCITY COUNTER x REGISTER

R/W-0	R/W-0	R/W-0	R/W-0	R/W-0	R/W-0	R/W-0	R/W-0
VELCNT<15:8>							
bit 15							bit 8

R/W-0	R/W-0	R/W-0	R/W-0	R/W-0	R/W-0	R/W-0	R/W-0
VELCNT<7:0>							
bit 7							bit 0

Legend:

R = Readable bit W = Writable bit U = Unimplemented bit, read as '0'
-n = Value at POR '1' = Bit is set '0' = Bit is cleared x = Bit is unknown

bit 15-0 **VELCNT<15:0>**: Velocity Counter x bits

REGISTER 17-8: INDXxCNTH: INDEX COUNTER x HIGH WORD REGISTER

R/W-0	R/W-0	R/W-0	R/W-0	R/W-0	R/W-0	R/W-0	R/W-0
INDXCNT<31:24>							
bit 15				bit 8			

R/W-0	R/W-0	R/W-0	R/W-0	R/W-0	R/W-0	R/W-0	R/W-0
INDXCNT<23:16>							
bit 7				bit 0			

Legend:							
R = Readable bit	W = Writable bit	U = Unimplemented bit, read as '0'					
-n = Value at POR	'1' = Bit is set	'0' = Bit is cleared	x = Bit is unknown				

bit 15-0 **INDXCNT<31:16>**: High Word Used to Form 32-Bit Index Counter x Register (INDXxCNT) bits

REGISTER 17-9: INDXxCNTL: INDEX COUNTER x LOW WORD REGISTER

R/W-0	R/W-0	R/W-0	R/W-0	R/W-0	R/W-0	R/W-0	R/W-0
INDXCNT<15:8>							
bit 15				bit 8			

R/W-0	R/W-0	R/W-0	R/W-0	R/W-0	R/W-0	R/W-0	R/W-0
INDXCNT<7:0>							
bit 7				bit 0			

Legend:							
R = Readable bit	W = Writable bit	U = Unimplemented bit, read as '0'					
-n = Value at POR	'1' = Bit is set	'0' = Bit is cleared	x = Bit is unknown				

bit 15-0 **INDXCNT<15:0>**: Low Word Used to Form 32-Bit Index Counter x Register (INDXxCNT) bits

dsPIC33EPXXXGM3XX/6XX/7XX

REGISTER 17-10: INDXxHLD: INDEX COUNTER x HOLD REGISTER

R/W-0	R/W-0	R/W-0	R/W-0	R/W-0	R/W-0	R/W-0	R/W-0
INDXHLD<15:8>							
bit 15				bit 8			

R/W-0	R/W-0	R/W-0	R/W-0	R/W-0	R/W-0	R/W-0	R/W-0
INDXHLD<7:0>							
bit 7				bit 0			

Legend:

R = Readable bit W = Writable bit U = Unimplemented bit, read as '0'
 -n = Value at POR '1' = Bit is set '0' = Bit is cleared x = Bit is unknown

bit 15-0 **INDXHLD<15:0>**: Holding Register for Reading and Writing INDXxCNT bits

REGISTER 17-11: QEIxICH: QEIx INITIALIZATION/CAPTURE HIGH WORD REGISTER

R/W-0	R/W-0	R/W-0	R/W-0	R/W-0	R/W-0	R/W-0	R/W-0
QEIIC<31:24>							
bit 15				bit 8			

R/W-0	R/W-0	R/W-0	R/W-0	R/W-0	R/W-0	R/W-0	R/W-0
QEIIC<23:16>							
bit 7				bit 0			

Legend:

R = Readable bit W = Writable bit U = Unimplemented bit, read as '0'
 -n = Value at POR '1' = Bit is set '0' = Bit is cleared x = Bit is unknown

bit 15-0 **QEIIC<31:16>**: High Word Used to Form 32-Bit Initialization/Capture Register (QEIxIC) bits

REGISTER 17-12: QEIxICL: QEIx INITIALIZATION/CAPTURE LOW WORD REGISTER

R/W-0	R/W-0	R/W-0	R/W-0	R/W-0	R/W-0	R/W-0	R/W-0
QEIIC<15:8>							
bit 15				bit 8			

R/W-0	R/W-0	R/W-0	R/W-0	R/W-0	R/W-0	R/W-0	R/W-0
QEIIC<7:0>							
bit 7				bit 0			

Legend:

R = Readable bit W = Writable bit U = Unimplemented bit, read as '0'
 -n = Value at POR '1' = Bit is set '0' = Bit is cleared x = Bit is unknown

bit 15-0 **QEIIC<15:0>**: Low Word Used to Form 32-Bit Initialization/Capture Register (QEIxIC) bits

dsPIC33EPXXXGM3XX/6XX/7XX

REGISTER 17-13: QEIXLECH: QEIX LESS THAN OR EQUAL COMPARE HIGH WORD REGISTER

R/W-0	R/W-0	R/W-0	R/W-0	R/W-0	R/W-0	R/W-0	R/W-0
QEILEC<31:24>							
bit 15				bit 8			

R/W-0	R/W-0	R/W-0	R/W-0	R/W-0	R/W-0	R/W-0	R/W-0
QEILEC<23:16>							
bit 7				bit 0			

Legend:

R = Readable bit

W = Writable bit

U = Unimplemented bit, read as '0'

-n = Value at POR

'1' = Bit is set

'0' = Bit is cleared

x = Bit is unknown

bit 15-0 **QEILEC<31:16>**: High Word Used to Form 32-Bit Less Than or Equal Compare Register (QEIXLEC) bits

REGISTER 17-14: QEIXLECL: QEIX LESS THAN OR EQUAL COMPARE LOW WORD REGISTER

R/W-0	R/W-0	R/W-0	R/W-0	R/W-0	R/W-0	R/W-0	R/W-0
QEILEC<15:8>							
bit 15				bit 8			

R/W-0	R/W-0	R/W-0	R/W-0	R/W-0	R/W-0	R/W-0	R/W-0
QEILEC<7:0>							
bit 7				bit 0			

Legend:

R = Readable bit

W = Writable bit

U = Unimplemented bit, read as '0'

-n = Value at POR

'1' = Bit is set

'0' = Bit is cleared

x = Bit is unknown

bit 15-0 **QEILEC<15:0>**: Low Word Used to Form 32-Bit Less Than or Equal Compare Register (QEIXLEC) bits

dsPIC33EPXXXGM3XX/6XX/7XX

REGISTER 17-15: QEIxGECH: QEIx GREATER THAN OR EQUAL COMPARE HIGH WORD REGISTER

R/W-0	R/W-0	R/W-0	R/W-0	R/W-0	R/W-0	R/W-0	R/W-0
QEIGEC<31:24>							
bit 15				bit 8			

R/W-0	R/W-0	R/W-0	R/W-0	R/W-0	R/W-0	R/W-0	R/W-0
QEIGEC<23:16>							
bit 7				bit 0			

Legend:

R = Readable bit W = Writable bit U = Unimplemented bit, read as '0'
 -n = Value at POR '1' = Bit is set '0' = Bit is cleared x = Bit is unknown

bit 15-0 **QEIGEC<31:16>**: High Word Used to Form 32-Bit Greater Than or Equal Compare Register (QEIxGEC) bits

REGISTER 17-16: QEIxGECL: QEIx GREATER THAN OR EQUAL COMPARE LOW WORD REGISTER

R/W-0	R/W-0	R/W-0	R/W-0	R/W-0	R/W-0	R/W-0	R/W-0
QEIGEC<15:8>							
bit 15				bit 8			

R/W-0	R/W-0	R/W-0	R/W-0	R/W-0	R/W-0	R/W-0	R/W-0
QEIGEC<7:0>							
bit 7				bit 0			

Legend:

R = Readable bit W = Writable bit U = Unimplemented bit, read as '0'
 -n = Value at POR '1' = Bit is set '0' = Bit is cleared x = Bit is unknown

bit 15-0 **QEIGEC<15:0>**: Low Word Used to Form 32-Bit Greater Than or Equal Compare Register (QEIxGEC) bits

REGISTER 17-17: INTxTMRH: INTERVAL TIMERx HIGH WORD REGISTER

R/W-0	R/W-0	R/W-0	R/W-0	R/W-0	R/W-0	R/W-0	R/W-0
INTTMR<31:24>							
bit 15				bit 8			

R/W-0	R/W-0	R/W-0	R/W-0	R/W-0	R/W-0	R/W-0	R/W-0
INTTMR<23:16>							
bit 7				bit 0			

Legend:							
R = Readable bit	W = Writable bit	U = Unimplemented bit, read as '0'					
-n = Value at POR	'1' = Bit is set	'0' = Bit is cleared	x = Bit is unknown				

bit 15-0 **INTTMR<31:16>**: High Word Used to Form 32-Bit Interval Timerx Register (INTxTMR) bits

REGISTER 17-18: INTxTMRL: INTERVAL TIMERx LOW WORD REGISTER

R/W-0	R/W-0	R/W-0	R/W-0	R/W-0	R/W-0	R/W-0	R/W-0
INTTMR<15:8>							
bit 15				bit 8			

R/W-0	R/W-0	R/W-0	R/W-0	R/W-0	R/W-0	R/W-0	R/W-0
INTTMR<7:0>							
bit 7				bit 0			

Legend:							
R = Readable bit	W = Writable bit	U = Unimplemented bit, read as '0'					
-n = Value at POR	'1' = Bit is set	'0' = Bit is cleared	x = Bit is unknown				

bit 15-0 **INTTMR<15:0>**: Low Word Used to Form 32-Bit Interval Timerx Register (INTxTMR) bits

dsPIC33EPXXXGM3XX/6XX/7XX

REGISTER 17-19: INTxHLDH: INTERVAL TIMERx HOLD HIGH WORD REGISTER

R/W-0	R/W-0	R/W-0	R/W-0	R/W-0	R/W-0	R/W-0	R/W-0
INTHLD<31:24>							
bit 15				bit 8			

R/W-0	R/W-0	R/W-0	R/W-0	R/W-0	R/W-0	R/W-0	R/W-0
INTHLD<23:16>							
bit 7				bit 0			

Legend:

R = Readable bit	W = Writable bit	U = Unimplemented bit, read as '0'
-n = Value at POR	'1' = Bit is set	'0' = Bit is cleared x = Bit is unknown

bit 15-0 **INTHLD<31:16>**: Holding Register for Reading and Writing INTxTMRH bits

REGISTER 17-20: INTxHLDL: INTERVAL TIMERx HOLD LOW WORD REGISTER

R/W-0	R/W-0	R/W-0	R/W-0	R/W-0	R/W-0	R/W-0	R/W-0
INTHLD<15:8>							
bit 15				bit 8			

R/W-0	R/W-0	R/W-0	R/W-0	R/W-0	R/W-0	R/W-0	R/W-0
INTHLD<7:0>							
bit 7				bit 0			

Legend:

R = Readable bit	W = Writable bit	U = Unimplemented bit, read as '0'
-n = Value at POR	'1' = Bit is set	'0' = Bit is cleared x = Bit is unknown

bit 15-0 **INTHLD<15:0>**: Holding Register for Reading and Writing INTxTMRL bits

18.0 SERIAL PERIPHERAL INTERFACE (SPI)

Note 1: This data sheet summarizes the features of the dsPIC33EPXXXGM3XX/6XX/7XX family of devices. It is not intended to be a comprehensive reference source. To complement the information in this data sheet, refer to the “dsPIC33/PIC24 Family Reference Manual”, “Serial Peripheral Interface (SPI)” (DS70005185), which is available from the Microchip web site (www.microchip.com).

2: Some registers and associated bits described in this section may not be available on all devices. Refer to [Section 4.0 “Memory Organization”](#) in this data sheet for device-specific register and bit information.

The SPI module is a synchronous serial interface, useful for communicating with other peripheral or microcontroller devices. These peripheral devices can be serial EEPROMs, shift registers, display drivers, A/D Converters, etc. The SPI module is compatible with the Motorola® SPI and SIOP interfaces.

The dsPIC33EPXXXGM3XX/6XX/7XX device family offers three SPI modules on a single device. These modules, which are designated as SPI1, SPI2 and SPI3, are functionally identical. Each SPI module includes an eight-word FIFO buffer and allows DMA bus connections. When using the SPI module with DMA, FIFO operation can be disabled.

Note: In this section, the SPI modules are referred to together as SPIx, or separately as SPI1, SPI2 and SPI3. Special Function Registers follow a similar notation. For example, SPIxCON refers to the control register for the SPI1, SPI2 and SPI3 modules.

The SPI1 module uses dedicated pins which allow for a higher speed when using SPI1. The SPI2 and SPI3 modules take advantage of the Peripheral Pin Select (PPS) feature to allow for greater flexibility in pin configuration of these modules, but results in a lower maximum speed. See [Section 33.0 “Electrical Characteristics”](#) for more information.

The SPIx serial interface consists of four pins, as follows:

- SDIx: Serial Data Input
- SDOx: Serial Data Output
- SCKx: Shift Clock Input or Output
- $\overline{\text{SSx}}$ /FSYNCx: Active-Low Slave Select or Frame Synchronization I/O Pulse

The SPIx module can be configured to operate with two, three or four pins. In 3-pin mode, $\overline{\text{SSx}}$ is not used. In 2-pin mode, neither SDOx nor $\overline{\text{SSx}}$ is used.

[Figure 18-1](#) illustrates the block diagram of the SPIx module in Standard and Enhanced modes.

dsPIC33EPXXXGM3XX/6XX/7XX

FIGURE 18-1: SPIx MODULE BLOCK DIAGRAM

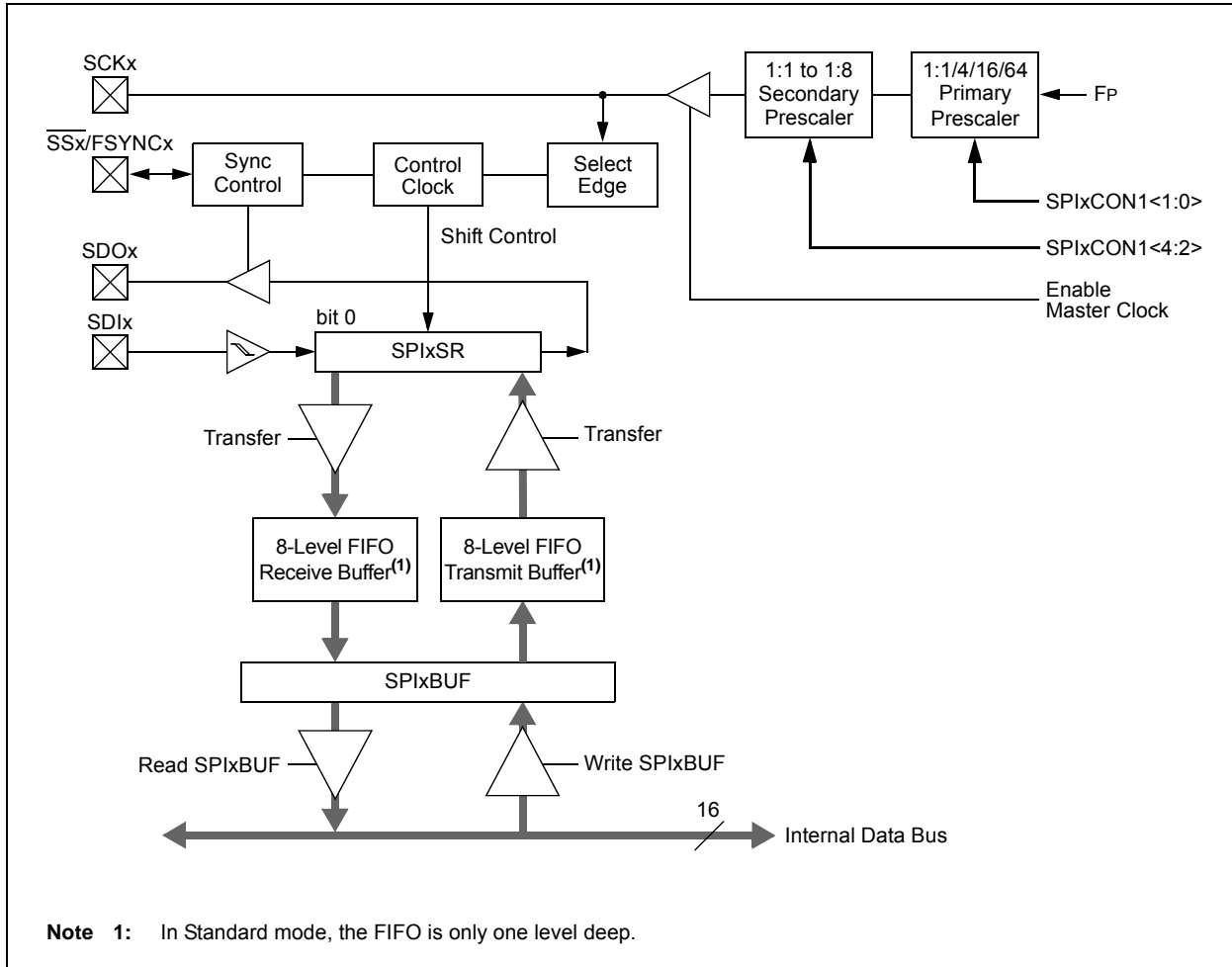

18.1 SPI Helpful Tips

1. In Frame mode, if there is a possibility that the master may not be initialized before the slave:
 - a) If FRMPOL (SPIxCON2<13>) = 1, use a pull-down resistor on \overline{SSx} .
 - b) If FRMPOL = 0, use a pull-up resistor on \overline{SSx} .

Note: This insures that the first frame transmission after initialization is not shifted or corrupted.

2. In Non-Framed 3-Wire mode (i.e., not using \overline{SSx} from a master):
 - a) If CKP (SPIxCON1<6>) = 1, always place a pull-up resistor on \overline{SSx} .
 - b) If CKP = 0, always place a pull-down resistor on \overline{SSx} .

Note: This will insure that during power-up and initialization, the master/slave will not lose sync due to an errant SCK transition that would cause the slave to accumulate data shift errors, for both transmit and receive, appearing as corrupted data.

3. FRMEN (SPIxCON2<15>) = 1 and SSEN (SPIxCON1<7>) = 1 are exclusive and invalid. In Frame mode, SCKx is continuous and the Frame Sync pulse is active on the \overline{SSx} pin, which indicates the start of a data frame.

Note: Not all third-party devices support Frame mode timing. Refer to the SPIx specifications in **Section 33.0 “Electrical Characteristics”** for details.

4. In Master mode only, set the SMP bit (SPIxCON1<9>) to a '1' for the fastest SPI data rate possible. The SMP bit can only be set at the same time or after the MSTEN bit (SPIxCON1<5>) is set.

To avoid invalid slave read data to the master, the user's master software must ensure enough time for slave software to fill its write buffer before the user application initiates a master write/read cycle. It is always advisable to preload the SPIxBUF Transmit register in advance of the next master transaction cycle. SPIxBUF is transferred to the SPIx Shift register and is empty once the data transmission begins.

dsPIC33EPXXXGM3XX/6XX/7XX

18.2 SPI Control Registers

REGISTER 18-1: SPIxSTAT: SPIx STATUS AND CONTROL REGISTER

R/W-0	U-0	R/W-0	U-0	U-0	R/W-0	R/W-0	R/W-0
SPIEN	—	SPISIDL	—	—	SPIBEC2	SPIBEC1	SPIBEC0
bit 15							bit 8

R/W-0	R/C-0, HS	R/W-0	R/W-0	R/W-0	R/W-0	R-0, HS, HC	R-0, HS, HC
SRMPT	SPIROV	SRXMPT	SISEL2	SISEL1	SISEL0	SPITBF	SPIRBF
bit 7							bit 0

Legend:

R = Readable bit W = Writable bit C = Clearable bit
 -n = Value at POR '1' = Bit is set '0' = Bit is cleared x = Bit is unknown
 HS = Hardware Settable bit HC = Hardware Clearable bit U = Unimplemented bit, read as '0'

- bit 15 **SPIEN:** SPIx Enable bit
 1 = Enables the module and configures SCKx, SDOx, SDIx and \overline{SSx} as serial port pins
 0 = Disables the module
- bit 14 **Unimplemented:** Read as '0'
- bit 13 **SPISIDL:** SPIx Stop in Idle Mode bit
 1 = Discontinues the module operation when device enters Idle mode
 0 = Continues the module operation in Idle mode
- bit 12-11 **Unimplemented:** Read as '0'
- bit 10-8 **SPIBEC<2:0>:** SPIx Buffer Element Count bits (valid in Enhanced Buffer mode)
Master mode:
 Number of SPIx transfers are pending.
Slave mode:
 Number of SPIx transfers are unread.
- bit 7 **SRMPT:** SPIx Shift Register (SPIxSR) Empty bit (valid in Enhanced Buffer mode)
 1 = SPIx Shift register is empty and ready to send or receive the data
 0 = SPIx Shift register is not empty
- bit 6 **SPIROV:** SPIx Receive Overflow Flag bit
 1 = A new byte/word is completely received and discarded; the user application has not read the previous data in the SPIxBUF register
 0 = No overflow has occurred
- bit 5 **SRXMPT:** SPIx Receive FIFO Empty bit (valid in Enhanced Buffer mode)
 1 = RX FIFO is empty
 0 = RX FIFO is not empty
- bit 4-2 **SISEL<2:0>:** SPIx Buffer Interrupt Mode bits (valid in Enhanced Buffer mode)
 111 = Interrupt when the SPIx transmit buffer is full (SPITBF bit is set)
 110 = Interrupt when the last bit is shifted into SPIxSR, and as a result, the TX FIFO is empty
 101 = Interrupt when the last bit is shifted out of SPIxSR and the transmit is complete
 100 = Interrupt when one data is shifted into SPIxSR, and as a result, the TX FIFO has one open memory location
 011 = Interrupt when the SPIx receive buffer is full (SPIRBF bit is set)
 010 = Interrupt when the SPIx receive buffer is 3/4 or more full
 001 = Interrupt when data is available in the SPIx receive buffer (SRMPT bit is set)
 000 = Interrupt when the last data in the SPIx receive buffer is read, and as a result, the buffer is empty (SRXMPT bit is set)

REGISTER 18-1: SPIxSTAT: SPIx STATUS AND CONTROL REGISTER (CONTINUED)

- bit 1 **SPITBF:** SPIx Transmit Buffer Full Status bit
1 = Transmit has not yet started, SPIxTXB is full
0 = Transmit has started, SPIxTXB is empty
Standard Buffer Mode:
Automatically set in hardware when the core writes to the SPIxBUF location, loading SPIxTXB. Automatically cleared in hardware when the SPIx module transfers data from SPIxTXB to SPIxSR.
Enhanced Buffer Mode:
Automatically set in hardware when the CPU writes to the SPIxBUF location, loading the last available buffer location. Automatically cleared in hardware when a buffer location is available for a CPU write operation.
- bit 0 **SPIRBF:** SPIx Receive Buffer Full Status bit
1 = Receive is complete, SPIxRXB is full
0 = Receive is incomplete, SPIxRXB is empty
Standard Buffer Mode:
Automatically set in hardware when SPIx transfers data from SPIxSR to SPIxRXB. Automatically cleared in hardware when the core reads the SPIxBUF location, reading SPIxRXB.
Enhanced Buffer Mode:
Automatically set in hardware when SPIx transfers data from SPIxSR to the buffer, filling the last unread buffer location. Automatically cleared in hardware when a buffer location is available for a transfer from SPIxSR.

dsPIC33EPXXXGM3XX/6XX/7XX

REGISTER 18-2: SPIxCON1: SPIx CONTROL REGISTER 1

U-0	U-0	U-0	R/W-0	R/W-0	R/W-0	R/W-0	R/W-0
—	—	—	DISSCK	DISSDO	MODE16	SMP	CKE ⁽¹⁾
bit 15							bit 8

R/W-0	R/W-0	R/W-0	R/W-0	R/W-0	R/W-0	R/W-0	R/W-0
SSEN ⁽²⁾	CKP	MSTEN	SPRE2 ⁽³⁾	SPRE1 ⁽³⁾	SPRE0 ⁽³⁾	PPRE1 ⁽³⁾	PPRE0 ⁽³⁾
bit 7							bit 0

Legend:

R = Readable bit W = Writable bit U = Unimplemented bit, read as '0'
 -n = Value at POR '1' = Bit is set '0' = Bit is cleared x = Bit is unknown

- bit 15-13 **Unimplemented:** Read as '0'
- bit 12 **DISSCK:** Disable SCKx Pin bit (SPI Master modes only)
 1 = Internal SPI clock is disabled, pin functions as I/O
 0 = Internal SPI clock is enabled
- bit 11 **DISSDO:** Disable SDOx Pin bit
 1 = SDOx pin is not used by the module; pin functions as I/O
 0 = SDOx pin is controlled by the module
- bit 10 **MODE16:** Word/Byte Communication Select bit
 1 = Communication is word-wide (16 bits)
 0 = Communication is byte-wide (8 bits)
- bit 9 **SMP:** SPIx Data Input Sample Phase bit
Master mode:
 1 = Input data is sampled at the end of data output time
 0 = Input data is sampled at the middle of data output time
Slave mode:
 SMP must be cleared when SPIx is used in Slave mode.
- bit 8 **CKE:** SPIx Clock Edge Select bit⁽¹⁾
 1 = Serial output data changes on transition from active clock state to Idle clock state (refer to bit 6)
 0 = Serial output data changes on transition from Idle clock state to active clock state (refer to bit 6)
- bit 7 **SSEN:** Slave Select Enable bit (Slave mode)⁽²⁾
 1 = \overline{SSx} pin is used for Slave mode
 0 = \overline{SSx} pin is not used by the module; pin is controlled by port function
- bit 6 **CKP:** Clock Polarity Select bit
 1 = Idle state for clock is a high level; active state is a low level
 0 = Idle state for clock is a low level; active state is a high level
- bit 5 **MSTEN:** Master Mode Enable bit
 1 = Master mode
 0 = Slave mode

- Note 1:** The CKE bit is not used in Framed SPI modes. Program this bit to '0' for Framed SPI modes (FRMEN = 1).
Note 2: This bit must be cleared when FRMEN = 1.
Note 3: Do not set both primary and secondary prescalers to the value of 1:1.

REGISTER 18-2: SPIxCON1: SPIx CONTROL REGISTER 1 (CONTINUED)

bit 4-2 **SPRE<2:0>**: Secondary Prescale bits (Master mode)⁽³⁾

111 = Secondary prescale 1:1

110 = Secondary prescale 2:1

•

•

•

000 = Secondary prescale 8:1

bit 1-0 **PPRE<1:0>**: Primary Prescale bits (Master mode)⁽³⁾

11 = Primary prescale 1:1

10 = Primary prescale 4:1

01 = Primary prescale 16:1

00 = Primary prescale 64:1

Note 1: The CKE bit is not used in Framed SPI modes. Program this bit to '0' for Framed SPI modes (FRMEN = 1).

2: This bit must be cleared when FRMEN = 1.

3: Do not set both primary and secondary prescalers to the value of 1:1.

dsPIC33EPXXXGM3XX/6XX/7XX

REGISTER 18-3: SPIxCON2: SPIx CONTROL REGISTER 2

R/W-0	R/W-0	R/W-0	U-0	U-0	U-0	U-0	U-0
FRMEN	SPIFSD	FRMPOL	—	—	—	—	—
bit 15							bit 8

U-0	U-0	U-0	U-0	U-0	U-0	R/W-0	R/W-0
—	—	—	—	—	—	FRMDLY	SPIBEN
bit 7						bit 0	

Legend:

R = Readable bit W = Writable bit U = Unimplemented bit, read as '0'
 -n = Value at POR '1' = Bit is set '0' = Bit is cleared x = Bit is unknown

- bit 15 **FRMEN:** Framed SPIx Support bit
 1 = Framed SPIx support is enabled (\overline{SSx} pin is used as the Frame Sync pulse input/output)
 0 = Framed SPIx support is disabled
- bit 14 **SPIFSD:** SPIx Frame Sync Pulse Direction Control bit
 1 = Frame Sync pulse input (slave)
 0 = Frame Sync pulse output (master)
- bit 13 **FRMPOL:** Frame Sync Pulse Polarity bit
 1 = Frame Sync pulse is active-high
 0 = Frame Sync pulse is active-low
- bit 12-2 **Unimplemented:** Read as '0'
- bit 1 **FRMDLY:** Frame Sync Pulse Edge Select bit
 1 = Frame Sync pulse coincides with first bit clock
 0 = Frame Sync pulse precedes first bit clock
- bit 0 **SPIBEN:** SPIx Enhanced Buffer Enable bit
 1 = Enhanced Buffer is enabled
 0 = Enhanced Buffer is disabled (Standard mode)

19.0 INTER-INTEGRATED CIRCUIT™ (I²C™)

Note 1: This data sheet summarizes the features of the dsPIC33EPXXXGM3XX/6XX/7XX family of devices. It is not intended to be a comprehensive reference source. To complement the information in this data sheet, refer to the “*dsPIC33/PIC24 Family Reference Manual*”, “**Inter-Integrated Circuit™ (I²C™)**” (DS70000195), which is available from the Microchip web site (www.microchip.com).

2: Some registers and associated bits described in this section may not be available on all devices. Refer to **Section 4.0 “Memory Organization”** in this data sheet for device-specific register and bit information.

The dsPIC33EPXXXGM3XX/6XX/7XX family of devices contains two Inter-Integrated Circuit (I²C) modules: I2C1 and I2C2.

The I²C module provides complete hardware support for both Slave and Multi-Master modes of the I²C serial communication standard, with a 16-bit interface.

The I²C module has a 2-pin interface:

- The SCLx pin is clock.
- The SDAx pin is data.

The I²C module offers the following key features:

- I²C Interface Supporting both Master and Slave modes of Operation.
- I²C Slave mode Supports 7 and 10-Bit Addressing.
- I²C Master mode Supports 7 and 10-Bit Addressing.
- I²C Port Allows Bidirectional Transfers Between Master and Slaves.
- Serial Clock Synchronization for I²C Port can be used as a Handshake Mechanism to Suspend and Resume Serial Transfer (SCLREL control).
- I²C Supports Multi-Master Operation, Detects Bus Collision and Arbitrates Accordingly.
- Intelligent Platform Management Interface (IPMI) Support
- System Management Bus (SMBus) Support

dsPIC33EPXXXGM3XX/6XX/7XX

FIGURE 19-1: I2Cx BLOCK DIAGRAM (x = 1 OR 2)

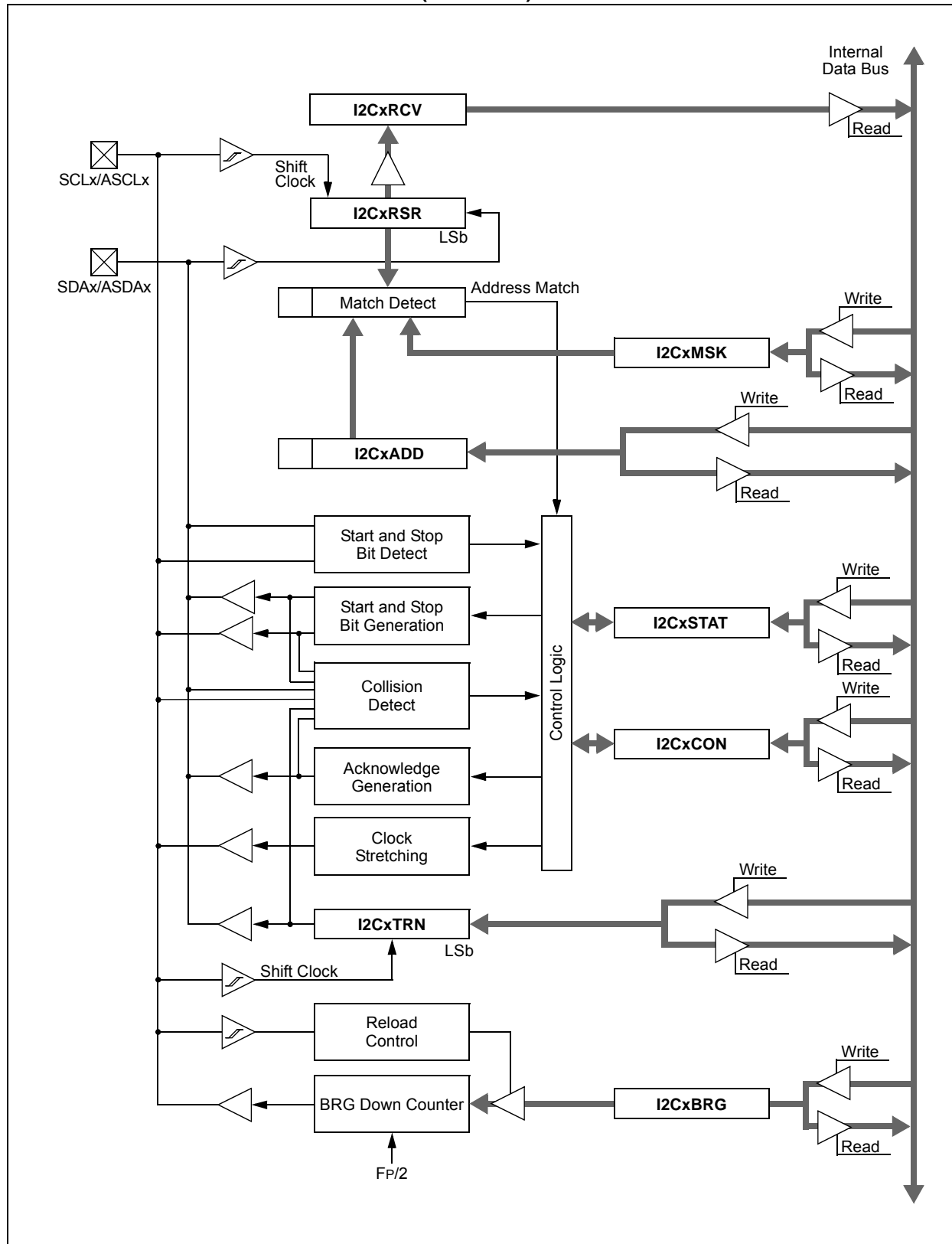

19.1 I²C Control Registers

REGISTER 19-1: I2CxCON: I2Cx CONTROL REGISTER

R/W-0	U-0	R/W-0	R/W-1, HC	R/W-0	R/W-0	R/W-0	R/W-0
I2CEN	—	I2CSIDL	SCLREL	IPMIEN ⁽¹⁾	A10M	DISSLW	SMEN
bit 15							bit 8

R/W-0	R/W-0	R/W-0	R/W-0, HC	R/W-0, HC	R/W-0, HC	R/W-0, HC	R/W-0, HC
GCEN	STREN	ACKDT	ACKEN	RCEN	PEN	RSEN	SEN
bit 7							bit 0

Legend:	HC = Hardware Clearable bit
R = Readable bit	W = Writable bit
-n = Value at POR	'1' = Bit is set
	'0' = Bit is cleared
	x = Bit is unknown
	U = Unimplemented bit, read as '0'

- bit 15 **I2CEN:** I2Cx Enable bit
 1 = Enables the I2Cx module and configures the SDAx and SCLx pins as serial port pins
 0 = Disables the I2Cx module; all I²C™ pins are controlled by port functions
- bit 14 **Unimplemented:** Read as '0'
- bit 13 **I2CSIDL:** I2Cx Stop in Idle Mode bit
 1 = Discontinues module operation when device enters an Idle mode
 0 = Continues module operation in Idle mode
- bit 12 **SCLREL:** SCLx Release Control bit (when operating as I²C™ slave)
 1 = Releases SCLx clock
 0 = Holds SCLx clock low (clock stretch)
If STREN = 1:
 Bit is R/W (i.e., software can write '0' to initiate stretch and write '1' to release clock). Hardware clears at the beginning of every slave data byte transmission. Hardware clears at the end of every slave address byte reception. Hardware clears at the end of every slave data byte reception.
If STREN = 0:
 Bit is R/S (i.e., software can only write '1' to release clock). Hardware clears at the beginning of every slave data byte transmission. Hardware clears at the end of every slave address byte reception.
- bit 11 **IPMIEN:** Intelligent Peripheral Management Interface (IPMI) Enable bit⁽¹⁾
 1 = IPMI mode is enabled; all addresses are Acknowledged
 0 = IPMI mode is disabled
- bit 10 **A10M:** 10-Bit Slave Address bit
 1 = I2CxADD is a 10-bit slave address
 0 = I2CxADD is a 7-bit slave address
- bit 9 **DISSLW:** Disable Slew Rate Control bit
 1 = Slew rate control is disabled
 0 = Slew rate control is enabled
- bit 8 **SMEN:** SMBus Input Levels bit
 1 = Enables I/O pin thresholds compliant with the SMBus specification
 0 = Disables SMBus input thresholds
- bit 7 **GCEN:** General Call Enable bit (when operating as I²C slave)
 1 = Enables interrupt when a general call address is received in the I2CxRSR (module is enabled for reception)
 0 = General call address is disabled

Note 1: When performing master operations, ensure that the IPMIEN bit is set to '0'.

dsPIC33EPXXXGM3XX/6XX/7XX

REGISTER 19-1: I2CxCON: I2Cx CONTROL REGISTER (CONTINUED)

- bit 6 **STREN:** SCLx Clock Stretch Enable bit (when operating as I²C slave)
Used in conjunction with the SCLREL bit.
1 = Enables software or receives clock stretching
0 = Disables software or receives clock stretching
- bit 5 **ACKDT:** Acknowledge Data bit (when operating as I²C master, applicable during master receive)
Value that is transmitted when the software initiates an Acknowledge sequence.
1 = Sends NACK during Acknowledge
0 = Sends ACK during Acknowledge
- bit 4 **ACKEN:** Acknowledge Sequence Enable bit
(when operating as I²C master, applicable during master receive)
1 = Initiates Acknowledge sequence on SDAx and SCLx pins and transmits ACKDT data bit;
hardware clears at the end of the master Acknowledge sequence
0 = Acknowledge sequence is not in progress
- bit 3 **RCEN:** Receive Enable bit (when operating as I²C master)
1 = Enables Receive mode for I²C; hardware clears at the end of the eighth bit of a master receive
data byte
0 = Receive sequence is not in progress
- bit 2 **PEN:** Stop Condition Enable bit (when operating as I²C master)
1 = Initiates Stop condition on SDAx and SCLx pins; hardware clears at the end of a master Stop
sequence
0 = Stop condition is not in progress
- bit 1 **RSEN:** Repeated Start Condition Enable bit (when operating as I²C master)
1 = Initiates Repeated Start condition on SDAx and SCLx pins; hardware clears at the end of a master
Repeated Start sequence
0 = Repeated Start condition is not in progress
- bit 0 **SEN:** Start Condition Enable bit (when operating as I²C master)
1 = Initiates Start condition on SDAx and SCLx pins; hardware clears at the end of a master Start
sequence
0 = Start condition is not in progress

Note 1: When performing master operations, ensure that the IPMIEN bit is set to '0'.

dsPIC33EPXXXGM3XX/6XX/7XX

REGISTER 19-2: I2CxSTAT: I2Cx STATUS REGISTER

R-0, HSC	R-0, HSC	U-0	U-0	U-0	R/C-0, HS	R-0, HSC	R-0, HSC
ACKSTAT	TRSTAT	—	—	—	BCL	GCSTAT	ADD10
bit 15						bit 8	

R/C-0, HS	R/C-0, HS	R-0, HSC	R/C-0, HSC	R/C-0, HSC	R-0, HSC	R-0, HSC	R-0, HSC
IWCOL	I2COV	D_A	P	S	R_W	RBF	TBF
bit 7						bit 0	

Legend:	C = Clearable bit	U = Unimplemented bit, read as '0'
R = Readable bit	W = Writable bit	HS = Hardware Settable bit HSC = Hardware Settable/Clearable bit
-n = Value at POR	'1' = Bit is set	'0' = Bit is cleared x = Bit is unknown

- bit 15 **ACKSTAT:** Acknowledge Status bit
(when operating as I²C™ master, applicable to master transmit operation)
1 = NACK received from slave
0 = ACK received from slave
Hardware sets or clears at the end of a slave Acknowledge.
- bit 14 **TRSTAT:** Transmit Status bit (when operating as I²C master, applicable to master transmit operation)
1 = Master transmit is in progress (8 bits + ACK)
0 = Master transmit is not in progress
Hardware sets at the beginning of a master transmission. Hardware clears at the end of a slave Acknowledge.
- bit 13-11 **Unimplemented:** Read as '0'
- bit 10 **BCL:** Master Bus Collision Detect bit
1 = A bus collision has been detected during a master operation
0 = No collision
Hardware sets at detection of a bus collision.
- bit 9 **GCSTAT:** General Call Status bit
1 = General call address was received
0 = General call address was not received
Hardware sets when address matches the general call address. Hardware clears at Stop detection.
- bit 8 **ADD10:** 10-Bit Address Status bit
1 = 10-bit address was matched
0 = 10-bit address was not matched
Hardware sets at a match of the 2nd byte of a matched 10-bit address. Hardware clears at Stop detection.
- bit 7 **IWCOL:** I2Cx Write Collision Detect bit
1 = An attempt to write to the I2CxTRN register failed because the I²C module is busy
0 = No collision
Hardware sets at an occurrence of a write to I2CxTRN while busy (cleared by software).
- bit 6 **I2COV:** I2Cx Receive Overflow Flag bit
1 = A byte was received while the I2CxRCV register was still holding the previous byte
0 = No overflow
Hardware sets at an attempt to transfer I2CxRSR to I2CxRCV (cleared by software).
- bit 5 **D_A:** Data/Address bit (when operating as I²C slave)
1 = Indicates that the last byte received was data
0 = Indicates that the last byte received was a device address
Hardware clears at a device address match. Hardware sets by reception of a slave byte.
- bit 4 **P:** Stop bit
1 = Indicates that a Stop bit has been detected last
0 = Stop bit was not detected last
Hardware sets or clears when Start, Repeated Start or Stop is detected.

REGISTER 19-2: I2CxSTAT: I2Cx STATUS REGISTER (CONTINUED)

- bit 3 **S:** Start bit
1 = Indicates that a Start (or Repeated Start) bit has been detected last
0 = Start bit was not detected last
Hardware sets or clears when Start, Repeated Start or Stop is detected.
- bit 2 **R_W:** Read/Write Information bit (when operating as I²C slave)
1 = Read – indicates data transfer is output from slave
0 = Write – indicates data transfer is input to slave
Hardware sets or clears after reception of an I²C device address byte.
- bit 1 **RBF:** Receive Buffer Full Status bit
1 = Receive is complete, I2CxRCV is full
0 = Receive is not complete, I2CxRCV is empty
Hardware sets when I2CxRCV is written with a received byte. Hardware clears when software reads I2CxRCV.
- bit 0 **TBF:** Transmit Buffer Full Status bit
1 = Transmit is in progress, I2CxTRN is full
0 = Transmit is complete, I2CxTRN is empty
Hardware sets when software writes to I2CxTRN. Hardware clears at completion of data transmission.

REGISTER 19-3: I2CxMSK: I2Cx SLAVE MODE ADDRESS MASK REGISTER

U-0	U-0	U-0	U-0	U-0	U-0	R/W-0	R/W-0
—	—	—	—	—	—	AMSK<9:8>	
bit 15						bit 8	

R/W-0	R/W-0	R/W-0	R/W-0	R/W-0	R/W-0	R/W-0	R/W-0
AMSK<7:0>							
bit 7						bit 0	

Legend:			
R = Readable bit	W = Writable bit	U = Unimplemented bit, read as '0'	
-n = Value at POR	'1' = Bit is set	'0' = Bit is cleared	x = Bit is unknown

- bit 15-10 **Unimplemented:** Read as '0'
- bit 9-0 **AMSK<9:0>:** Address Mask Select bits
 - For 10-Bit Address:
 - 1 = Enables masking for bit, Ax, of incoming message address; bit match is not required in this position
 - 0 = Disables masking for bit, Ax; bit match is required in this position
 - For 7-Bit Address (I2CxMSK<6:0> only):
 - 1 = Enables masking for bit, Ax + 1, of incoming message address; bit match is not required in this position
 - 0 = Disables masking for bit, Ax + 1; bit match is required in this position

dsPIC33EPXXGM3XX/6XX/7XX

NOTES:

20.0 UNIVERSAL ASYNCHRONOUS RECEIVER TRANSMITTER (UART)

Note 1: This data sheet summarizes the features of the dsPIC33EPXXXGM3XX/6XX/7XX family of devices. It is not intended to be a comprehensive reference source. To complement the information in this data sheet, refer to the “dsPIC33/PIC24 Family Reference Manual”, “Universal Asynchronous Receiver Transmitter (UART)” (DS70000582), which is available from the Microchip web site (www.microchip.com).

2: Some registers and associated bits described in this section may not be available on all devices. Refer to [Section 4.0 “Memory Organization”](#) in this data sheet for device-specific register and bit information.

The dsPIC33EPXXXGM3XX/6XX/7XX family of devices contains four UART modules.

The Universal Asynchronous Receiver Transmitter (UART) module is one of the serial I/O modules available in the dsPIC33EPXXXGM3XX/6XX/7XX device family. The UART is a full-duplex, asynchronous system that can communicate with peripheral devices, such as personal computers, LIN/J2602, RS-232 and RS-485 interfaces. The module also supports a hardware flow control option with the UxCTS and UxRTS pins, and also includes an IrDA® encoder and decoder.

Note: Hardware flow control using UxRTS and UxCTS is not available on all pin count devices. See the “Pin Diagrams” section for availability.

The primary features of the UART module are:

- Full-Duplex, 8 or 9-Bit Data Transmission through the UxTX and UxRX Pins
- Even, Odd or No Parity Options (for 8-bit data)
- One or Two Stop Bits
- Hardware Flow Control Option with \overline{UxCTS} and \overline{UxRTS} Pins
- Fully Integrated Baud Rate Generator with 16-Bit Prescaler
- Baud Rates Ranging from 4.375 Mbps to 67 bps at 16x mode at 70 MIPS
- Baud Rates Ranging from 17.5 Mbps to 267 bps at 4x mode at 70 MIPS
- 4-Deep First-In First-Out (FIFO) Transmit Data Buffer
- 4-Deep FIFO Receive Data Buffer
- Parity, Framing and Buffer Overrun Error Detection
- Support for 9-Bit mode with Address Detect (9th bit = 1)
- Transmit and Receive Interrupts
- A Separate Interrupt for All UART Error Conditions
- Loopback mode for Diagnostic Support
- Support for Sync and Break Characters
- Support for Automatic Baud Rate Detection
- IrDA® Encoder and Decoder Logic
- 16x Baud Clock Output for IrDA® Support

A simplified block diagram of the UART module is shown in [Figure 20-1](#). The UART module consists of these key hardware elements:

- Baud Rate Generator
- Asynchronous Transmitter
- Asynchronous Receiver

FIGURE 20-1: UARTx SIMPLIFIED BLOCK DIAGRAM

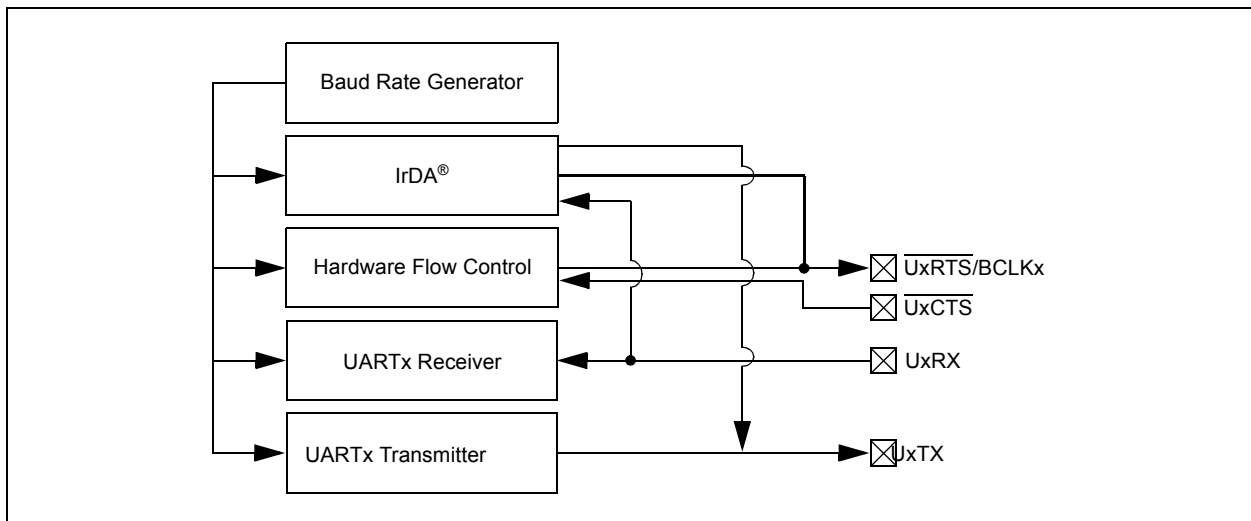

20.1 UART Helpful Tips

1. In multi-node direct connect UART networks, UART receive inputs react to the complementary logic level defined by the URXINV bit (UxMODE<4>), which defines the Idle state, the default of which is logic high (i.e., URXINV = 0). Because remote devices do not initialize at the same time, it is likely that one of the devices, because the RX line is floating, will trigger a Start bit detection and will cause the first byte received, after the device has been initialized, to be invalid. To avoid this situation, the user should use a pull-up or pull-down resistor on the RX pin, depending on the value of the URXINV bit.
 - a) If URXINV = 0, use a pull-up resistor on the RX pin.
 - b) If URXINV = 1, use a pull-down resistor on the RX pin.
2. The first character received on wake-up from Sleep mode, caused by activity on the UxRX pin of the UART module, will be invalid. In Sleep mode, peripheral clocks are disabled. By the time the oscillator system has restarted and stabilized from Sleep mode, the baud rate bit sampling clock, relative to the incoming UxRX bit timing, is no longer synchronized, resulting in the first character being invalid. This is to be expected.

20.2 UART Control Registers

REGISTER 20-1: UxMODE: UARTx MODE REGISTER

R/W-0	U-0	R/W-0	R/W-0	R/W-0	U-0	R/W-0	R/W-0
UARTEN ⁽¹⁾	—	USIDL	IREN ⁽²⁾	RTSMD	—	UEN1	UEN0
bit 15							bit 8

R/W-0, HC	R/W-0	R/W-0, HC	R/W-0	R/W-0	R/W-0	R/W-0	R/W-0
WAKE	LPBACK	ABAUD	URXINV	BRGH	PDSEL1	PDSEL0	STSEL
bit 7							bit 0

Legend:	HC = Hardware Clearable bit	
R = Readable bit	W = Writable bit	U = Unimplemented bit, read as '0'
-n = Value at POR	'1' = Bit is set	'0' = Bit is cleared x = Bit is unknown

- bit 15 **UARTEN:** UARTx Enable bit⁽¹⁾
 1 = UARTx is enabled; all UARTx pins are controlled by UARTx as defined by UEN<1:0>
 0 = UARTx is disabled; all UARTx pins are controlled by PORT latches; UARTx power consumption is minimal
- bit 14 **Unimplemented:** Read as '0'
- bit 13 **USIDL:** UARTx Stop in Idle Mode bit
 1 = Discontinues module operation when device enters Idle mode
 0 = Continues module operation in Idle mode
- bit 12 **IREN:** IrDA[®] Encoder and Decoder Enable bit⁽²⁾
 1 = IrDA encoder and decoder are enabled
 0 = IrDA encoder and decoder are disabled
- bit 11 **RTSMD:** Mode Selection for \overline{UxRTS} Pin bit
 1 = \overline{UxRTS} pin is in Simplex mode
 0 = \overline{UxRTS} pin is in Flow Control mode
- bit 10 **Unimplemented:** Read as '0'
- bit 9-8 **UEN<1:0>:** UARTx Pin Enable bits
 11 = UxTX, UxRX and BCLKx pins are enabled and used; \overline{UxCTS} pin is controlled by PORT latches⁽³⁾
 10 = UxTX, UxRX, \overline{UxCTS} and \overline{UxRTS} pins are enabled and used⁽⁴⁾
 01 = UxTX, UxRX and \overline{UxRTS} pins are enabled and used; \overline{UxCTS} pin is controlled by PORT latches⁽⁴⁾
 00 = UxTX and UxRX pins are enabled and used; \overline{UxCTS} and \overline{UxRTS} /BCLKx pins are controlled by PORT latches
- bit 7 **WAKE:** Wake-up on Start bit Detect During Sleep Mode Enable bit
 1 = UARTx continues to sample the UxRX pin, interrupt is generated on the falling edge; bit is cleared in hardware on the following rising edge
 0 = No wake-up is enabled
- bit 6 **LPBACK:** UARTx Loopback Mode Select bit
 1 = Enables Loopback mode
 0 = Loopback mode is disabled

- Note 1:** Refer to the “dsPIC33/PIC24 Family Reference Manual”, “Universal Asynchronous Receiver Transmitter (UART)” (DS70000582) for information on enabling the UART module for receive or transmit operation.
- 2:** This feature is only available for the 16x BRG mode (BRGH = 0).
 - 3:** This feature is only available on 44-pin and 64-pin devices.
 - 4:** This feature is only available on 64-pin devices.

dsPIC33EPXXGM3XX/6XX/7XX

REGISTER 20-1: UxMODE: UARTx MODE REGISTER (CONTINUED)

- bit 5 **ABAUD:** Auto-Baud Enable bit
1 = Enables baud rate measurement on the next character – requires reception of a Sync field (55h) before other data; cleared in hardware upon completion
0 = Baud rate measurement is disabled or has completed
- bit 4 **URXINV:** UARTx Receive Polarity Inversion bit
1 = UxRX Idle state is '0'
0 = UxRX Idle state is '1'
- bit 3 **BRGH:** High Baud Rate Enable bit
1 = BRG generates 4 clocks per bit period (4x baud clock, High-Speed mode)
0 = BRG generates 16 clocks per bit period (16x baud clock, Standard mode)
- bit 2-1 **PDSEL<1:0>:** Parity and Data Selection bits
11 = 9-bit data, no parity
10 = 8-bit data, odd parity
01 = 8-bit data, even parity
00 = 8-bit data, no parity
- bit 0 **STSEL:** Stop Bit Selection bit
1 = Two Stop bits
0 = One Stop bit

- Note 1:** Refer to the “*dsPIC33/PIC24 Family Reference Manual*”, “**Universal Asynchronous Receiver Transmitter (UART)**” (DS70000582) for information on enabling the UART module for receive or transmit operation.
- 2:** This feature is only available for the 16x BRG mode (BRGH = 0).
- 3:** This feature is only available on 44-pin and 64-pin devices.
- 4:** This feature is only available on 64-pin devices.

dsPIC33EPXXXGM3XX/6XX/7XX

REGISTER 20-2: UxSTA: UARTx STATUS AND CONTROL REGISTER

R/W-0	R/W-0	R/W-0	U-0	R/W-0, HC	R/W-0	R-0	R-1
UTXISEL1	UTXINV	UTXISEL0	—	UTXBRK	UTXEN ⁽¹⁾	UTXBF	TRMT
bit 15						bit 8	

R/W-0	R/W-0	R/W-0	R-1	R-0	R-0	R/C-0	R-0
URXISEL1	URXISEL0	ADDEN	RIDLE	PERR	FERR	OERR	URXDA
bit 7						bit 0	

Legend:	C = Clearable bit	HC = Hardware Clearable bit
R = Readable bit	W = Writable bit	U = Unimplemented bit, read as '0'
-n = Value at POR	'1' = Bit is set	'0' = Bit is cleared
		x = Bit is unknown

- bit 15,13 **UTXISEL<1:0>**: UARTx Transmission Interrupt Mode Selection bits
 11 = Reserved; do not use
 10 = Interrupt when a character is transferred to the Transmit Shift Register (TSR), and as a result, the transmit buffer becomes empty
 01 = Interrupt when the last character is shifted out of the Transmit Shift Register; all transmit operations are completed
 00 = Interrupt when a character is transferred to the Transmit Shift Register (this implies there is at least one character open in the transmit buffer)
- bit 14 **UTXINV**: UARTx Transmit Polarity Inversion bit
 If IREN = 0:
 1 = UxTX Idle state is '0'
 0 = UxTX Idle state is '1'
 If IREN = 1:
 1 = IrDA encoded UxTX Idle state is '1'
 0 = IrDA encoded UxTX Idle state is '0'
- bit 12 **Unimplemented**: Read as '0'
- bit 11 **UTXBRK**: UARTx Transmit Break bit
 1 = Sends Sync Break on next transmission – Start bit, followed by twelve '0' bits, followed by Stop bit; cleared by hardware upon completion
 0 = Sync Break transmission is disabled or has completed
- bit 10 **UTXEN**: UARTx Transmit Enable bit⁽¹⁾
 1 = Transmit is enabled, UxTX pin is controlled by UARTx
 0 = Transmit is disabled, any pending transmission is aborted and the buffer is reset; UxTX pin is controlled by the PORT
- bit 9 **UTXBF**: UARTx Transmit Buffer Full Status bit (read-only)
 1 = Transmit buffer is full
 0 = Transmit buffer is not full, at least one more character can be written
- bit 8 **TRMT**: Transmit Shift Register Empty bit (read-only)
 1 = Transmit Shift Register is empty and transmit buffer is empty (the last transmission has completed)
 0 = Transmit Shift Register is not empty, a transmission is in progress or queued
- bit 7-6 **URXISEL<1:0>**: UARTx Receive Interrupt Mode Selection bits
 11 = Interrupt is set on UxRSR transfer, making the receive buffer full (i.e., has 4 data characters)
 10 = Interrupt is set on UxRSR transfer, making the receive buffer 3/4 full (i.e., has 3 data characters)
 0x = Interrupt is set when any character is received and transferred from the UxRSR to the receive buffer; receive buffer has one or more characters

Note 1: Refer to the “dsPIC33/PIC24 Family Reference Manual”, “Universal Asynchronous Receiver Transmitter (UART)” (DS70000582) for information on enabling the UART module for transmit operation.

dsPIC33EPXXGM3XX/6XX/7XX

REGISTER 20-2: UxSTA: UARTx STATUS AND CONTROL REGISTER (CONTINUED)

- bit 5 **ADDEN:** Address Character Detect bit (bit 8 of received data = 1)
1 = Address Detect mode is enabled; if 9-bit mode is not selected, this does not take effect
0 = Address Detect mode is disabled
- bit 4 **RIDLE:** Receiver Idle bit (read-only)
1 = Receiver is Idle
0 = Receiver is active
- bit 3 **PERR:** Parity Error Status bit (read-only)
1 = Parity error has been detected for the current character (character at the top of the receive FIFO)
0 = Parity error has not been detected
- bit 2 **FERR:** Framing Error Status bit (read-only)
1 = Framing error has been detected for the current character (character at the top of the receive FIFO)
0 = Framing error has not been detected
- bit 1 **OERR:** Receive Buffer Overrun Error Status bit (clear/read-only)
1 = Receive buffer has overflowed
0 = Receive buffer has not overflowed; clearing a previously set OERR bit (1 → 0 transition) resets the receive buffer and the UxRSR to the empty state
- bit 0 **URXDA:** UARTx Receive Buffer Data Available bit (read-only)
1 = Receive buffer has data, at least one more character can be read
0 = Receive buffer is empty

Note 1: Refer to the “*dsPIC33/PIC24 Family Reference Manual*”, “**Universal Asynchronous Receiver Transmitter (UART)**” (DS70000582) for information on enabling the UART module for transmit operation.

21.0 CONTROLLER AREA NETWORK (CAN) MODULE (dsPIC33EPXXXGM6XX/7XX DEVICES ONLY)

Note 1: This data sheet summarizes the features of the dsPIC33EPXXXGM3XX/6XX/7XX family of devices. It is not intended to be a comprehensive reference source. To complement the information in this data sheet, refer to the “dsPIC33/PIC24 Family Reference Manual”, “Enhanced Controller Area Network (ECAN™)” (DS70353), which is available from the Microchip web site (www.microchip.com).

2: Some registers and associated bits described in this section may not be available on all devices. Refer to [Section 4.0 “Memory Organization”](#) in this data sheet for device-specific register and bit information.

21.1 Overview

The Controller Area Network (CAN) module is a serial interface, useful for communicating with other CAN modules or microcontroller devices. This interface/protocol was designed to allow communications within noisy environments. The dsPIC33EPXXXGM6XX/7XX devices contain two CAN modules.

The CAN module is a communication controller, implementing the CAN 2.0 A/B protocol, as defined in the BOSCH CAN specification. The module supports CAN 1.2, CAN 2.0A, CAN 2.0B Passive and CAN 2.0B Active versions of the protocol. The module implementation is a full CAN system. The CAN specification is not covered within this data sheet. The reader can refer to the BOSCH CAN specification for further details.

The CAN module features are as follows:

- Implementation of the CAN protocol, CAN 1.2, CAN 2.0A and CAN 2.0B
- Standard and Extended Data Frames
- 0-8 Bytes of Data Length
- Programmable Bit Rate, up to 1 Mbit/sec
- Automatic Response to Remote Transmission Requests
- Up to 8 Transmit Buffers with Application Specified Prioritization and Abort Capability (each buffer can contain up to 8 bytes of data)
- Up to 32 Receive Buffers (each buffer can contain up to 8 bytes of data)
- Up to 16 Full (Standard/Extended Identifier) Acceptance Filters
- Three Full Acceptance Filter Masks
- DeviceNet™ Addressing Support
- Programmable Wake-up Functionality with Integrated Low-Pass Filter
- Programmable Loopback mode supports Self-Test Operation
- Signaling via Interrupt Capabilities for all CAN Receiver and Transmitter Error States
- Programmable Clock Source
- Programmable Link to Input Capture 2 (IC2) module for Timestamping and Network Synchronization
- Low-Power Sleep and Idle modes

The CAN bus module consists of a protocol engine and message buffering/control. The CAN protocol engine handles all functions for receiving and transmitting messages on the CAN bus. Messages are transmitted by first loading the appropriate data registers. Status and errors can be checked by reading the appropriate registers. Any message detected on the CAN bus is checked for errors and then matched against filters to see if it should be received and stored in one of the receive registers.

dsPIC33EPXXXGM3XX/6XX/7XX

FIGURE 21-1: CANx MODULE BLOCK DIAGRAM

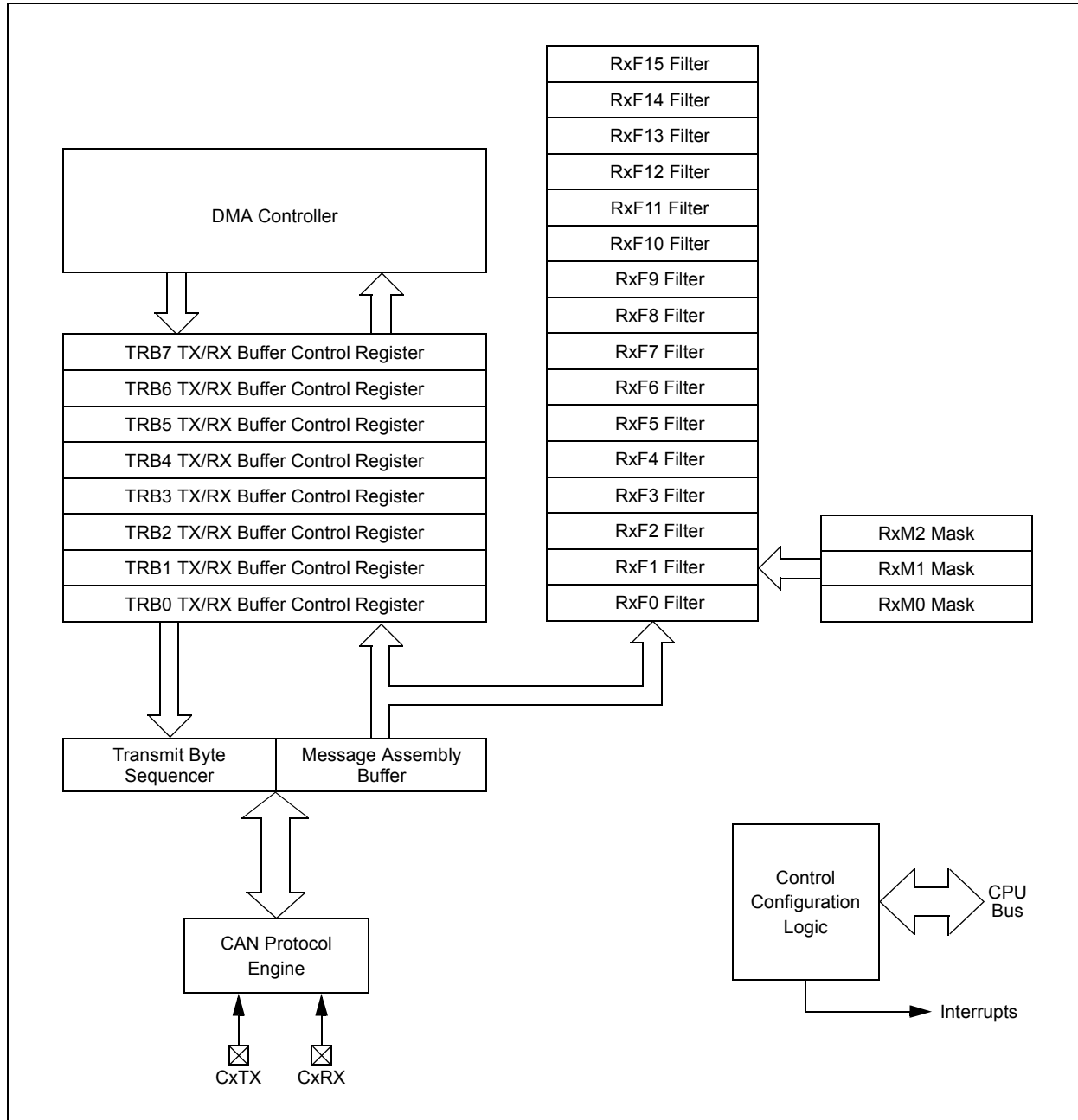

21.2 Modes of Operation

The CANx module can operate in one of several operation modes selected by the user. These modes include:

- Initialization mode
- Disable mode
- Normal Operation mode
- Listen Only mode
- Listen All Messages mode
- Loopback mode

Modes are requested by setting the REQOP<2:0> bits (CxCTRL1<10:8>). Entry into a mode is Acknowledged by monitoring the OPMODE<2:0> bits (CxCTRL1<7:5>). The module does not change the mode and the OPMODEx bits until a change in mode is acceptable, generally during bus Idle time, which is defined as at least 11 consecutive recessive bits.

21.3 CAN Control Registers

REGISTER 21-1: CxCTRL1: CANx CONTROL REGISTER 1

U-0	U-0	R/W-0	R/W-0	R/W-0	R/W-1	R/W-0	R/W-0
—	—	CSIDL	ABAT	CANCKS	REQOP2	REQOP1	REQOP0
bit 15							bit 8

R-1	R-0	R-0	U-0	R/W-0	U-0	U-0	R/W-0
OPMODE2	OPMODE1	OPMODE0	—	CANCAP	—	—	WIN
bit 7							bit 0

Legend:

R = Readable bit	W = Writable bit	U = Unimplemented bit, read as '0'
-n = Value at POR	'1' = Bit is set	'0' = Bit is cleared x = Bit is unknown

- bit 15-14 **Unimplemented:** Read as '0'
- bit 13 **CSIDL:** CANx Stop in Idle Mode bit
 1 = Discontinues module operation when device enters Idle mode
 0 = Continues module operation in Idle mode
- bit 12 **ABAT:** Abort All Pending Transmissions bit
 1 = Signals all transmit buffers to abort transmission
 0 = Module will clear this bit when all transmissions are aborted
- bit 11 **CANCKS:** CANx Module Clock (FCAN) Source Select bit
 1 = FCAN is equal to 2 * FP
 0 = FCAN is equal to FP
- bit 10-8 **REQOP<2:0>:** Request Operation Mode bits
 111 = Set Listen All Messages mode
 110 = Reserved
 101 = Reserved
 100 = Set Configuration mode
 011 = Set Listen Only mode
 010 = Set Loopback mode
 001 = Set Disable mode
 000 = Set Normal Operation mode
- bit 7-5 **OPMODE<2:0>:** Operation Mode bits
 111 = Module is in Listen All Messages mode
 110 = Reserved
 101 = Reserved
 100 = Module is in Configuration mode
 011 = Module is in Listen Only mode
 010 = Module is in Loopback mode
 001 = Module is in Disable mode
 000 = Module is in Normal Operation mode
- bit 4 **Unimplemented:** Read as '0'
- bit 3 **CANCAP:** CANx Message Receive Timer Capture Event Enable bit
 1 = Enables input capture based on CAN message receive
 0 = Disables CAN capture
- bit 2-1 **Unimplemented:** Read as '0'
- bit 0 **WIN:** SFR Map Window Select bit
 1 = Uses filter window
 0 = Uses buffer window

dsPIC33EPXXXGM3XX/6XX/7XX

REGISTER 21-2: CxCTRL2: CANx CONTROL REGISTER 2

U-0	U-0	U-0	U-0	U-0	U-0	U-0	U-0
—	—	—	—	—	—	—	—
bit 15						bit 8	

U-0	U-0	U-0	R-0	R-0	R-0	R-0	R-0
—	—	—	DNCNT<4:0>				
bit 7						bit 0	

Legend:

R = Readable bit	W = Writable bit	U = Unimplemented bit, read as '0'
-n = Value at POR	'1' = Bit is set	'0' = Bit is cleared
		x = Bit is unknown

bit 15-5 **Unimplemented:** Read as '0'

bit 4-0 **DNCNT<4:0>:** DeviceNet™ Filter Bit Number bits
 10010-11111 = Invalid selection
 10001 = Compare up to Data Byte 3, bit 6 with EID<17>
 •
 •
 •
 00001 = Compare up to Data Byte 1, bit 7 with EID<0>
 00000 = Do not compare data bytes

REGISTER 21-3: CxVEC: CANx INTERRUPT CODE REGISTER

U-0	U-0	U-0	R-0	R-0	R-0	R-0	R-0
—	—	—	FILHIT4	FILHIT3	FILHIT2	FILHIT1	FILHIT0
bit 15							bit 8

U-0	R-1	R-0	R-0	R-0	R-0	R-0	R-0
—	ICODE6	ICODE5	ICODE4	ICODE3	ICODE2	ICODE1	ICODE0
bit 7							bit 0

Legend:
R = Readable bit W = Writable bit U = Unimplemented bit, read as '0'
-n = Value at POR '1' = Bit is set '0' = Bit is cleared x = Bit is unknown

- bit 15-13 **Unimplemented:** Read as '0'
- bit 12-8 **FILHIT<4:0>:** Filter Hit Number bits
 - 10000-11111 = Reserved
 - 01111 = Filter 15
 -
 -
 -
 - 00001 = Filter 1
 - 00000 = Filter 0
- bit 7 **Unimplemented:** Read as '0'
- bit 6-0 **ICODE<6:0>:** Interrupt Flag Code bits
 - 1000101-1111111 = Reserved
 - 1000100 = FIFO almost full interrupt
 - 1000011 = Receiver overflow interrupt
 - 1000010 = Wake-up interrupt
 - 1000001 = Error interrupt
 - 1000000 = No interrupt
 -
 -
 -
 - 0010000-0111111 = Reserved
 - 0001111 = RB15 buffer interrupt
 -
 -
 -
 - 0001001 = RB9 buffer interrupt
 - 0001000 = RB8 buffer interrupt
 - 0000111 = TRB7 buffer interrupt
 - 0000110 = TRB6 buffer interrupt
 - 0000101 = TRB5 buffer interrupt
 - 0000100 = TRB4 buffer interrupt
 - 0000011 = TRB3 buffer interrupt
 - 0000010 = TRB2 buffer interrupt
 - 0000001 = TRB1 buffer interrupt
 - 0000000 = TRB0 buffer interrupt

dsPIC33EPXXXGM3XX/6XX/7XX

REGISTER 21-4: CxFCTRL: CANx FIFO CONTROL REGISTER

R/W-0	R/W-0	R/W-0	U-0	U-0	U-0	U-0	U-0
DMABS2	DMABS1	DMABS0	—	—	—	—	—
bit 15							bit 8

U-0	U-0	U-0	R/W-0	R/W-0	R/W-0	R/W-0	R/W-0
—	—	—	FSA4	FSA3	FSA2	FSA1	FSA0
bit 7							bit 0

Legend:

R = Readable bit W = Writable bit U = Unimplemented bit, read as '0'
 -n = Value at POR '1' = Bit is set '0' = Bit is cleared x = Bit is unknown

bit 15-13 **DMABS<2:0>**: DMA Buffer Size bits

- 111 = Reserved
- 110 = 32 buffers in RAM
- 101 = 24 buffers in RAM
- 100 = 16 buffers in RAM
- 011 = 12 buffers in RAM
- 010 = 8 buffers in RAM
- 001 = 6 buffers in RAM
- 000 = 4 buffers in RAM

bit 12-5 **Unimplemented**: Read as '0'

bit 4-0 **FSA<4:0>**: FIFO Area Starts with Buffer bits

- 11111 = Receive Buffer RB31
- 11110 = Receive Buffer RB30
-
-
-
- 00001 = Transmit/Receive Buffer TRB1
- 00000 = Transmit/Receive Buffer TRB0

REGISTER 21-5: CxFIFO: CANx FIFO STATUS REGISTER

U-0	U-0	R-0	R-0	R-0	R-0	R-0	R-0
—	—	FBP5	FBP4	FBP3	FBP2	FBP1	FBP0
bit 15							bit 8

U-0	U-0	R-0	R-0	R-0	R-0	R-0	R-0
—	—	FNRB5	FNRB4	FNRB3	FNRB2	FNRB1	FNRB0
bit 7							bit 0

Legend:			
R = Readable bit	W = Writable bit	U = Unimplemented bit, read as '0'	
-n = Value at POR	'1' = Bit is set	'0' = Bit is cleared	x = Bit is unknown

bit 15-14 **Unimplemented:** Read as '0'

bit 13-8 **FBP<5:0>:** FIFO Buffer Pointer bits

011111 = RB31 buffer

011110 = RB30 buffer

•

•

•

000001 = TRB1 buffer

000000 = TRB0 buffer

bit 7-6 **Unimplemented:** Read as '0'

bit 5-0 **FNRB<5:0>:** FIFO Next Read Buffer Pointer bits

011111 = RB31 buffer

011110 = RB30 buffer

•

•

•

000001 = TRB1 buffer

000000 = TRB0 buffer

dsPIC33EPXXXGM3XX/6XX/7XX

REGISTER 21-6: CxINTF: CANx INTERRUPT FLAG REGISTER

U-0	U-0	R-0	R-0	R-0	R-0	R-0	R-0
—	—	TXBO	TXBP	RXBP	TXWAR	RXWAR	EWARN
bit 15							bit 8

R/C-0	R/C-0	R/C-0	U-0	R/C-0	R/C-0	R/C-0	R/C-0
IVRIF	WAKIF	ERRIF	—	FIFOIF	RBOVIF	RBIF	TBIF
bit 7							bit 0

Legend:	C = Writable bit, but only '0' can be written to clear the bit
R = Readable bit	W = Writable bit U = Unimplemented bit, read as '0'
-n = Value at POR	'1' = Bit is set '0' = Bit is cleared x = Bit is unknown

- bit 15-14 **Unimplemented:** Read as '0'
- bit 13 **TXBO:** Transmitter in Error State Bus Off bit
1 = Transmitter is in Bus Off state
0 = Transmitter is not in Bus Off state
- bit 12 **TXBP:** Transmitter in Error State Bus Passive bit
1 = Transmitter is in Bus Passive state
0 = Transmitter is not in Bus Passive state
- bit 11 **RXBP:** Receiver in Error State Bus Passive bit
1 = Receiver is in Bus Passive state
0 = Receiver is not in Bus Passive state
- bit 10 **TXWAR:** Transmitter in Error State Warning bit
1 = Transmitter is in Error Warning state
0 = Transmitter is not in Error Warning state
- bit 9 **RXWAR:** Receiver in Error State Warning bit
1 = Receiver is in Error Warning state
0 = Receiver is not in Error Warning state
- bit 8 **EWARN:** Transmitter or Receiver in Error State Warning bit
1 = Transmitter or receiver is in Error Warning state
0 = Transmitter or receiver is not in Error Warning state
- bit 7 **IVRIF:** Invalid Message Interrupt Flag bit
1 = Interrupt request has occurred
0 = Interrupt request has not occurred
- bit 6 **WAKIF:** Bus Wake-up Activity Interrupt Flag bit
1 = Interrupt request has occurred
0 = Interrupt request has not occurred
- bit 5 **ERRIF:** Error Interrupt Flag bit (multiple sources in CxINTF<13:8> register)
1 = Interrupt request has occurred
0 = Interrupt request has not occurred
- bit 4 **Unimplemented:** Read as '0'
- bit 3 **FIFOIF:** FIFO Almost Full Interrupt Flag bit
1 = Interrupt request has occurred
0 = Interrupt request has not occurred
- bit 2 **RBOVIF:** RX Buffer Overflow Interrupt Flag bit
1 = Interrupt request has occurred
0 = Interrupt request has not occurred

REGISTER 21-6: CxINTF: CANx INTERRUPT FLAG REGISTER (CONTINUED)

- bit 1 **RBIF:** RX Buffer Interrupt Flag bit
 1 = Interrupt request has occurred
 0 = Interrupt request has not occurred
- bit 0 **TBIF:** TX Buffer Interrupt Flag bit
 1 = Interrupt request has occurred
 0 = Interrupt request has not occurred

REGISTER 21-7: CxINTE: CANx INTERRUPT ENABLE REGISTER

U-0	U-0	U-0	U-0	U-0	U-0	U-0	U-0
—	—	—	—	—	—	—	—
bit 15							bit 8

R/W-0	R/W-0	R/W-0	U-0	R/W-0	R/W-0	R/W-0	R/W-0
IVRIE	WAKIE	ERRIE	—	FIFOIE	RBOVIE	RBIE	TBIE
bit 7							bit 0

Legend:

R = Readable bit	W = Writable bit	U = Unimplemented bit, read as '0'
-n = Value at POR	'1' = Bit is set	'0' = Bit is cleared x = Bit is unknown

- bit 15-8 **Unimplemented:** Read as '0'
- bit 7 **IVRIE:** Invalid Message Interrupt Enable bit
 1 = Interrupt request is enabled
 0 = Interrupt request is not enabled
- bit 6 **WAKIE:** Bus Wake-up Activity Interrupt Enable bit
 1 = Interrupt request is enabled
 0 = Interrupt request is not enabled
- bit 5 **ERRIE:** Error Interrupt Enable bit
 1 = Interrupt request is enabled
 0 = Interrupt request is not enabled
- bit 4 **Unimplemented:** Read as '0'
- bit 3 **FIFOIE:** FIFO Almost Full Interrupt Enable bit
 1 = Interrupt request is enabled
 0 = Interrupt request is not enabled
- bit 2 **RBOVIE:** RX Buffer Overflow Interrupt Enable bit
 1 = Interrupt request is enabled
 0 = Interrupt request is not enabled
- bit 1 **RBIE:** RX Buffer Interrupt Enable bit
 1 = Interrupt request is enabled
 0 = Interrupt request is not enabled
- bit 0 **TBIE:** TX Buffer Interrupt Enable bit
 1 = Interrupt request is enabled
 0 = Interrupt request is not enabled

dsPIC33EPXXXGM3XX/6XX/7XX

REGISTER 21-8: CxEC: CANx TRANSMIT/RECEIVE ERROR COUNT REGISTER

R-0	R-0	R-0	R-0	R-0	R-0	R-0	R-0
TERRCNT7	TERRCNT6	TERRCNT5	TERRCNT4	TERRCNT3	TERRCNT2	TERRCNT1	TERRCNT0
bit 15							bit 8

R-0	R-0	R-0	R-0	R-0	R-0	R-0	R-0
RERRCNT7	RERRCNT6	RERRCNT5	RERRCNT4	RERRCNT3	RERRCNT2	RERRCNT1	RERRCNT0
bit 7							bit 0

Legend:

R = Readable bit W = Writable bit U = Unimplemented bit, read as '0'
 -n = Value at POR '1' = Bit is set '0' = Bit is cleared x = Bit is unknown

bit 15-8 **TERRCNT<7:0>**: Transmit Error Count bits
 bit 7-0 **RERRCNT<7:0>**: Receive Error Count bits

REGISTER 21-9: CxCFG1: CANx BAUD RATE CONFIGURATION REGISTER 1

U-0	U-0	U-0	U-0	U-0	U-0	U-0	U-0
—	—	—	—	—	—	—	—
bit 15							bit 8

R/W-0	R/W-0	R/W-0	R/W-0	R/W-0	R/W-0	R/W-0	R/W-0
SJW1	SJW0	BRP5	BRP4	BRP3	BRP2	BRP1	BRP0
bit 7							bit 0

Legend:

R = Readable bit W = Writable bit U = Unimplemented bit, read as '0'
 -n = Value at POR '1' = Bit is set '0' = Bit is cleared x = Bit is unknown

bit 15-8 **Unimplemented**: Read as '0'
 bit 7-6 **SJW<1:0>**: Synchronization Jump Width bits
 11 = Length is 4 x TQ
 10 = Length is 3 x TQ
 01 = Length is 2 x TQ
 00 = Length is 1 x TQ
 bit 5-0 **BRP<5:0>**: Baud Rate Prescaler bits
 11 1111 = TQ = 2 x 64 x 1/FCAN
 •
 •
 •
 00 0010 = TQ = 2 x 3 x 1/FCAN
 00 0001 = TQ = 2 x 2 x 1/FCAN
 00 0000 = TQ = 2 x 1 x 1/FCAN

dsPIC33EPXXXGM3XX/6XX/7XX

REGISTER 21-10: CxCFG2: CANx BAUD RATE CONFIGURATION REGISTER 2

U-0	R/W-x	U-0	U-0	U-0	R/W-x	R/W-x	R/W-x
—	WAKFIL	—	—	—	SEG2PH2	SEG2PH1	SEG2PH0
bit 15						bit 8	

R/W-x	R/W-x	R/W-x	R/W-x	R/W-x	R/W-x	R/W-x	R/W-x
SEG2PHTS	SAM	SEG1PH2	SEG1PH1	SEG1PH0	PRSEG2	PRSEG1	PRSEG0
bit 7						bit 0	

Legend:

R = Readable bit W = Writable bit U = Unimplemented bit, read as '0'
-n = Value at POR '1' = Bit is set '0' = Bit is cleared x = Bit is unknown

- bit 15 **Unimplemented:** Read as '0'
- bit 14 **WAKFIL:** Select CAN Bus Line Filter for Wake-up bit
1 = Uses CAN bus line filter for wake-up
0 = CAN bus line filter is not used for wake-up
- bit 13-11 **Unimplemented:** Read as '0'
- bit 10-8 **SEG2PH<2:0>:** Phase Segment 2 bits
111 = Length is 8 x Tq
•
•
•
000 = Length is 1 x Tq
- bit 7 **SEG2PHTS:** Phase Segment 2 Time Select bit
1 = Freely programmable
0 = Maximum of SEG1PHx bits or Information Processing Time (IPT), whichever is greater
- bit 6 **SAM:** Sample of the CAN Bus Line bit
1 = Bus line is sampled three times at the sample point
0 = Bus line is sampled once at the sample point
- bit 5-3 **SEG1PH<2:0>:** Phase Segment 1 bits
111 = Length is 8 x Tq
•
•
•
000 = Length is 1 x Tq
- bit 2-0 **PRSEG<2:0>:** Propagation Time Segment bits
111 = Length is 8 x Tq
•
•
•
000 = Length is 1 x Tq

REGISTER 21-13: CxBUFNT2: CANx FILTERS 4-7 BUFFER POINTER REGISTER 2

R/W-0	R/W-0	R/W-0	R/W-0	R/W-0	R/W-0	R/W-0	R/W-0
F7BP3	F7BP2	F7BP1	F7BP0	F6BP3	F6BP2	F6BP1	F6BP0
bit 15							bit 8

R/W-0	R/W-0	R/W-0	R/W-0	R/W-0	R/W-0	R/W-0	R/W-0
F5BP3	F5BP2	F5BP1	F5BP0	F4BP3	F4BP2	F4BP1	F4BP0
bit 7							bit 0

Legend:

R = Readable bit	W = Writable bit	U = Unimplemented bit, read as '0'
-n = Value at POR	'1' = Bit is set	'0' = Bit is cleared x = Bit is unknown

- bit 15-12 **F7BP<3:0>**: RX Buffer Mask for Filter 7 bits
 1111 = Filter hits received in RX FIFO buffer
 1110 = Filter hits received in RX Buffer 14
 .
 .
 .
 0001 = Filter hits received in RX Buffer 1
 0000 = Filter hits received in RX Buffer 0
- bit 11-8 **F6BP<3:0>**: RX Buffer Mask for Filter 6 bits (same values as bits 15-12)
- bit 7-4 **F5BP<3:0>**: RX Buffer Mask for Filter 5 bits (same values as bits 15-12)
- bit 3-0 **F4BP<3:0>**: RX Buffer Mask for Filter 4 bits (same values as bits 15-12)

REGISTER 21-14: CxBUFNT3: CANx FILTERS 8-11 BUFFER POINTER REGISTER 3

R/W-0	R/W-0	R/W-0	R/W-0	R/W-0	R/W-0	R/W-0	R/W-0
F11BP3	F11BP2	F11BP1	F11BP0	F10BP3	F10BP2	F10BP1	F10BP0
bit 15							bit 8

R/W-0	R/W-0	R/W-0	R/W-0	R/W-0	R/W-0	R/W-0	R/W-0
F9BP3	F9BP2	F9BP1	F9BP0	F8BP3	F8BP2	F8BP1	F8BP0
bit 7							bit 0

Legend:

R = Readable bit	W = Writable bit	U = Unimplemented bit, read as '0'
-n = Value at POR	'1' = Bit is set	'0' = Bit is cleared x = Bit is unknown

- bit 15-12 **F11BP<3:0>**: RX Buffer Mask for Filter 11 bits
 1111 = Filter hits received in RX FIFO buffer
 1110 = Filter hits received in RX Buffer 14
 .
 .
 .
 0001 = Filter hits received in RX Buffer 1
 0000 = Filter hits received in RX Buffer 0
- bit 11-8 **F10BP<3:0>**: RX Buffer Mask for Filter 10 bits (same values as bits 15-12)
- bit 7-4 **F9BP<3:0>**: RX Buffer Mask for Filter 9 bits (same values as bits 15-12)
- bit 3-0 **F8BP<3:0>**: RX Buffer Mask for Filter 8 bits (same values as bits 15-12)

dsPIC33EPXXXGM3XX/6XX/7XX

REGISTER 21-15: CxBUFPNT4: CANx FILTERS 12-15 BUFFER POINTER REGISTER 4

R/W-0	R/W-0	R/W-0	R/W-0	R/W-0	R/W-0	R/W-0	R/W-0
F15BP3	F15BP2	F15BP1	F15BP0	F14BP3	F14BP2	F14BP1	F14BP0
bit 15							bit 8

R/W-0	R/W-0	R/W-0	R/W-0	R/W-0	R/W-0	R/W-0	R/W-0
F13BP3	F13BP2	F13BP1	F13BP0	F12BP3	F12BP2	F12BP1	F12BP0
bit 7							bit 0

Legend:

R = Readable bit

W = Writable bit

U = Unimplemented bit, read as '0'

-n = Value at POR

'1' = Bit is set

'0' = Bit is cleared

x = Bit is unknown

bit 15-12 **F15BP<3:0>**: RX Buffer Mask for Filter 15 bits

1111 = Filter hits received in RX FIFO buffer

1110 = Filter hits received in RX Buffer 14

•

•

•

0001 = Filter hits received in RX Buffer 1

0000 = Filter hits received in RX Buffer 0

bit 11-8 **F14BP<3:0>**: RX Buffer Mask for Filter 14 bits (same values as bits 15-12)

bit 7-4 **F13BP<3:0>**: RX Buffer Mask for Filter 13 bits (same values as bits 15-12)

bit 3-0 **F12BP<3:0>**: RX Buffer Mask for Filter 12 bits (same values as bits 15-12)

REGISTER 21-16: CxRXFnSID: CANx ACCEPTANCE FILTER n STANDARD IDENTIFIER REGISTER (n = 0-15)

R/W-x	R/W-x	R/W-x	R/W-x	R/W-x	R/W-x	R/W-x	R/W-x
SID10	SID9	SID8	SID7	SID6	SID5	SID4	SID3
bit 15							bit 8

R/W-x	R/W-x	R/W-x	U-0	R/W-x	U-0	R/W-x	R/W-x
SID2	SID1	SID0	—	EXIDE	—	EID17	EID16
bit 7							bit 0

Legend:

R = Readable bit	W = Writable bit	U = Unimplemented bit, read as '0'
-n = Value at POR	'1' = Bit is set	'0' = Bit is cleared
		x = Bit is unknown

- bit 15-5 **SID<10:0>**: Standard Identifier bits
 - 1 = Message address bit, SIDx, must be '1' to match filter
 - 0 = Message address bit, SIDx, must be '0' to match filter
- bit 4 **Unimplemented**: Read as '0'
- bit 3 **EXIDE**: Extended Identifier Enable bit
 - If MIDE = 1:
 - 1 = Matches only messages with Extended Identifier addresses
 - 0 = Matches only messages with Standard Identifier addresses
 - If MIDE = 0:
 - Ignores EXIDE bit.
- bit 2 **Unimplemented**: Read as '0'
- bit 1-0 **EID<17:16>**: Extended Identifier bits
 - 1 = Message address bit, EIDx, must be '1' to match filter
 - 0 = Message address bit, EIDx, must be '0' to match filter

REGISTER 21-17: CxRXFnEID: CANx ACCEPTANCE FILTER n EXTENDED IDENTIFIER REGISTER (n = 0-15)

R/W-x	R/W-x	R/W-x	R/W-x	R/W-x	R/W-x	R/W-x	R/W-x
EID<15:8>							
bit 15							bit 8

R/W-x	R/W-x	R/W-x	R/W-x	R/W-x	R/W-x	R/W-x	R/W-x
EID<7:0>							
bit 7							bit 0

Legend:

R = Readable bit	W = Writable bit	U = Unimplemented bit, read as '0'
-n = Value at POR	'1' = Bit is set	'0' = Bit is cleared
		x = Bit is unknown

- bit 15-0 **EID<15:0>**: Extended Identifier bits
 - 1 = Message address bit, EIDx, must be '1' to match filter
 - 0 = Message address bit, EIDx, must be '0' to match filter

dsPIC33EPXXXGM3XX/6XX/7XX

REGISTER 21-18: CxFMSKSEL1: CANx FILTERS 7-0 MASK SELECTION REGISTER 1

R/W-0	R/W-0	R/W-0	R/W-0	R/W-0	R/W-0	R/W-0	R/W-0
F7MSK1	F7MSK0	F6MSK1	F6MSK0	F5MSK1	F5MSK0	F4MSK1	F4MSK0
bit 15							bit 8

R/W-0	R/W-0	R/W-0	R/W-0	R/W-0	R/W-0	R/W-0	R/W-0
F3MSK1	F3MSK0	F2MSK1	F2MSK0	F1MSK1	F1MSK0	F0MSK1	F0MSK0
bit 7							bit 0

Legend:

R = Readable bit W = Writable bit U = Unimplemented bit, read as '0'
 -n = Value at POR '1' = Bit is set '0' = Bit is cleared x = Bit is unknown

- bit 15-14 **F7MSK<1:0>**: Mask Source for Filter 7 bit
 11 = Reserved
 10 = Acceptance Mask 2 registers contain mask
 01 = Acceptance Mask 1 registers contain mask
 00 = Acceptance Mask 0 registers contain mask
- bit 13-12 **F6MSK<1:0>**: Mask Source for Filter 6 bit (same values as bits 15-14)
- bit 11-10 **F5MSK<1:0>**: Mask Source for Filter 5 bit (same values as bits 15-14)
- bit 9-8 **F4MSK<1:0>**: Mask Source for Filter 4 bit (same values as bits 15-14)
- bit 7-6 **F3MSK<1:0>**: Mask Source for Filter 3 bit (same values as bits 15-14)
- bit 5-4 **F2MSK<1:0>**: Mask Source for Filter 2 bit (same values as bits 15-14)
- bit 3-2 **F1MSK<1:0>**: Mask Source for Filter 1 bit (same values as bits 15-14)
- bit 1-0 **F0MSK<1:0>**: Mask Source for Filter 0 bit (same values as bits 15-14)

REGISTER 21-19: CxFMSKSEL2: CANx FILTERS 15-8 MASK SELECTION REGISTER 2

R/W-0	R/W-0	R/W-0	R/W-0	R/W-0	R/W-0	R/W-0	R/W-0
F15MSK1	F15MSK0	F14MSK1	F14MSK0	F13MSK1	F13MSK0	F12MSK1	F12MSK0
bit 15							bit 8

R/W-0	R/W-0	R/W-0	R/W-0	R/W-0	R/W-0	R/W-0	R/W-0
F11MSK1	F11MSK0	F10MSK1	F10MSK0	F9MSK1	F9MSK0	F8MSK1	F8MSK0
bit 7							bit 0

Legend:			
R = Readable bit	W = Writable bit	U = Unimplemented bit, read as '0'	
-n = Value at POR	'1' = Bit is set	'0' = Bit is cleared	x = Bit is unknown

- bit 15-14 **F15MSK<1:0>**: Mask Source for Filter 15 bit
 11 = Reserved
 10 = Acceptance Mask 2 registers contain mask
 01 = Acceptance Mask 1 registers contain mask
 00 = Acceptance Mask 0 registers contain mask
- bit 13-12 **F14MSK<1:0>**: Mask Source for Filter 14 bit (same values as bits 15-14)
- bit 11-10 **F13MSK<1:0>**: Mask Source for Filter 13 bit (same values as bits 15-14)
- bit 9-8 **F12MSK<1:0>**: Mask Source for Filter 12 bit (same values as bits 15-14)
- bit 7-6 **F11MSK<1:0>**: Mask Source for Filter 11 bit (same values as bits 15-14)
- bit 5-4 **F10MSK<1:0>**: Mask Source for Filter 10 bit (same values as bits 15-14)
- bit 3-2 **F9MSK<1:0>**: Mask Source for Filter 9 bit (same values as bits 15-14)
- bit 1-0 **F8MSK<1:0>**: Mask Source for Filter 8 bit (same values as bits 15-14)

dsPIC33EPXXXGM3XX/6XX/7XX

REGISTER 21-20: CxRXMnSID: CANx ACCEPTANCE FILTER MASK n STANDARD IDENTIFIER REGISTER (n = 0-2)

R/W-x	R/W-x	R/W-x	R/W-x	R/W-x	R/W-x	R/W-x	R/W-x
SID10	SID9	SID8	SID7	SID6	SID5	SID4	SID3
bit 15						bit 8	

R/W-x	R/W-x	R/W-x	U-0	R/W-x	U-0	R/W-x	R/W-x
SID2	SID1	SID0	—	MIDE	—	EID17	EID16
bit 7						bit 0	

Legend:

R = Readable bit W = Writable bit U = Unimplemented bit, read as '0'
-n = Value at POR '1' = Bit is set '0' = Bit is cleared x = Bit is unknown

- bit 15-5 **SID<10:0>**: Standard Identifier bits
 - 1 = Includes bit, SIDx, in filter comparison
 - 0 = Bit, SIDx, is a don't care in filter comparison
- bit 4 **Unimplemented**: Read as '0'
- bit 3 **MIDE**: Identifier Receive Mode bit
 - 1 = Matches only message types (standard or extended address) that correspond to the EXIDE bit in the filter
 - 0 = Matches either standard or extended address message if filters match (i.e., if (Filter SIDx) = (Message SIDx) or if (Filter SIDx/EIDx) = (Message SIDx/EIDx))
- bit 2 **Unimplemented**: Read as '0'
- bit 1-0 **EID<17:16>**: Extended Identifier bits
 - 1 = Includes bit, EIDx, in filter comparison
 - 0 = Bit, EIDx, is a don't care in filter comparison

REGISTER 21-21: CxRXMnEID: CANx ACCEPTANCE FILTER MASK n EXTENDED IDENTIFIER REGISTER (n = 0-2)

R/W-x	R/W-x	R/W-x	R/W-x	R/W-x	R/W-x	R/W-x	R/W-x
EID<15:8>							
bit 15						bit 8	

R/W-x	R/W-x	R/W-x	R/W-x	R/W-x	R/W-x	R/W-x	R/W-x
EID<7:0>							
bit 7						bit 0	

Legend:

R = Readable bit W = Writable bit U = Unimplemented bit, read as '0'
-n = Value at POR '1' = Bit is set '0' = Bit is cleared x = Bit is unknown

- bit 15-0 **EID<15:0>**: Extended Identifier bits
 - 1 = Includes bit, EIDx, in filter comparison
 - 0 = Bit, EIDx, is a don't care in filter comparison

dsPIC33EPXXXGM3XX/6XX/7XX

REGISTER 21-22: CxRXFUL1: CANx RECEIVE BUFFER FULL REGISTER 1

R/C-0	R/C-0	R/C-0	R/C-0	R/C-0	R/C-0	R/C-0	R/C-0
RXFUL<15:8>							
bit 15							bit 8

R/C-0	R/C-0	R/C-0	R/C-0	R/C-0	R/C-0	R/C-0	R/C-0
RXFUL<7:0>							
bit 7							bit 0

Legend:	C = Writable bit, but only '0' can be written to clear the bit
R = Readable bit	W = Writable bit U = Unimplemented bit, read as '0'
-n = Value at POR	'1' = Bit is set '0' = Bit is cleared x = Bit is unknown

bit 15-0 **RXFUL<15:0>**: Receive Buffer n Full bits
 1 = Buffer is full (set by module)
 0 = Buffer is empty (cleared by user software)

REGISTER 21-23: CxRXFUL2: CANx RECEIVE BUFFER FULL REGISTER 2

R/C-0	R/C-0	R/C-0	R/C-0	R/C-0	R/C-0	R/C-0	R/C-0
RXFUL<31:24>							
bit 15							bit 8

R/C-0	R/C-0	R/C-0	R/C-0	R/C-0	R/C-0	R/C-0	R/C-0
RXFUL<23:16>							
bit 7							bit 0

Legend:	C = Writable bit, but only '0' can be written to clear the bit
R = Readable bit	W = Writable bit U = Unimplemented bit, read as '0'
-n = Value at POR	'1' = Bit is set '0' = Bit is cleared x = Bit is unknown

bit 15-0 **RXFUL<31:16>**: Receive Buffer n Full bits
 1 = Buffer is full (set by module)
 0 = Buffer is empty (cleared by user software)

dsPIC33EPXXXGM3XX/6XX/7XX

REGISTER 21-24: CxRXOVF1: CANx RECEIVE BUFFER OVERFLOW REGISTER 1

R/C-0	R/C-0	R/C-0	R/C-0	R/C-0	R/C-0	R/C-0	R/C-0
RXOVF<15:8>							
bit 15							bit 8

R/C-0	R/C-0	R/C-0	R/C-0	R/C-0	R/C-0	R/C-0	R/C-0
RXOVF<7:0>							
bit 7							bit 0

Legend:	C = Writable bit, but only '0' can be written to clear the bit		
R = Readable bit	W = Writable bit	U = Unimplemented bit, read as '0'	
-n = Value at POR	'1' = Bit is set	'0' = Bit is cleared	x = Bit is unknown

bit 15-0 **RXOVF<15:0>**: Receive Buffer n Overflow bits
1 = Module attempted to write to a full buffer (set by module)
0 = No overflow condition (cleared by user software)

REGISTER 21-25: CxRXOVF2: CANx RECEIVE BUFFER OVERFLOW REGISTER 2

R/C-0	R/C-0	R/C-0	R/C-0	R/C-0	R/C-0	R/C-0	R/C-0
RXOVF<31:24>							
bit 15							bit 8

R/C-0	R/C-0	R/C-0	R/C-0	R/C-0	R/C-0	R/C-0	R/C-0
RXOVF<23:16>							
bit 7							bit 0

Legend:	C = Writable bit, but only '0' can be written to clear the bit		
R = Readable bit	W = Writable bit	U = Unimplemented bit, read as '0'	
-n = Value at POR	'1' = Bit is set	'0' = Bit is cleared	x = Bit is unknown

bit 15-0 **RXOVF<31:16>**: Receive Buffer n Overflow bits
1 = Module attempted to write to a full buffer (set by module)
0 = No overflow condition (cleared by user software)

REGISTER 21-26: CxTRmnCON: CANx TX/RX BUFFER mn CONTROL REGISTER
(m = 0,2,4,6; n = 1,3,5,7)

R/W-0	R-0	R-0	R-0	R/W-0	R/W-0	R/W-0	R/W-0
TXENn	TXABTn	TXLARBn	TXERRn	TXREQn	RTRENn	TXnPRI1	TXnPRI0
bit 15							bit 8

R/W-0	R-0	R-0	R-0	R/W-0	R/W-0	R/W-0	R/W-0
TXENm	TXABTm ⁽¹⁾	TXLARBm ⁽¹⁾	TXERRm ⁽¹⁾	TXREQm	RTRENm	TXmPRI1	TXmPRI0
bit 7							bit 0

Legend:

R = Readable bit	W = Writable bit	U = Unimplemented bit, read as '0'
-n = Value at POR	'1' = Bit is set	'0' = Bit is cleared
		x = Bit is unknown

- bit 15-8 See Definition for bits 7-0, controls Buffer n
- bit 7 **TXENm:** TX/RX Buffer Selection bit
 1 = Buffer, TRBn, is a transmit buffer
 0 = Buffer, TRBn, is a receive buffer
- bit 6 **TXABTm:** Message Aborted bit⁽¹⁾
 1 = Message was aborted
 0 = Message completed transmission successfully
- bit 5 **TXLARBm:** Message Lost Arbitration bit⁽¹⁾
 1 = Message lost arbitration while being sent
 0 = Message did not lose arbitration while being sent
- bit 4 **TXERRm:** Error Detected During Transmission bit⁽¹⁾
 1 = A bus error occurred while the message was being sent
 0 = A bus error did not occur while the message was being sent
- bit 3 **TXREQm:** Message Send Request bit
 1 = Requests that a message be sent; the bit automatically clears when the message is successfully sent
 0 = Clearing the bit to '0' while set requests a message abort
- bit 2 **RTRENm:** Auto-Remote Transmit Enable bit
 1 = When a remote transmit is received, TXREQx will be set
 0 = When a remote transmit is received, TXREQx will be unaffected
- bit 1-0 **TXmPRI<1:0>:** Message Transmission Priority bits
 11 = Highest message priority
 10 = High intermediate message priority
 01 = Low intermediate message priority
 00 = Lowest message priority

Note 1: This bit is cleared when TXREQx is set.

Note: The buffers, SIDx, EIDx, DLCx, Data Field, and Receive Status registers, are located in DMA RAM.

dsPIC33EPXXXGM3XX/6XX/7XX

21.4 CAN Message Buffers

CAN Message Buffers are part of RAM memory. They are not CAN Special Function Registers. The user application must directly write into the RAM area that is configured for CAN Message Buffers. The location and size of the buffer area is defined by the user application.

BUFFER 21-1: CANx MESSAGE BUFFER WORD 0

U-0	U-0	U-0	R/W-x	R/W-x	R/W-x	R/W-x	R/W-x
—	—	—	SID10	SID9	SID8	SID7	SID6
bit 15							bit 8

R/W-x	R/W-x	R/W-x	R/W-x	R/W-x	R/W-x	R/W-x	R/W-x
SID5	SID4	SID3	SID2	SID1	SID0	SRR	IDE
bit 7							bit 0

Legend:

R = Readable bit	W = Writable bit	U = Unimplemented bit, read as '0'
-n = Value at POR	'1' = Bit is set	'0' = Bit is cleared
		x = Bit is unknown

- bit 15-13 **Unimplemented:** Read as '0'
- bit 12-2 **SID<10:0>:** Standard Identifier bits
- bit 1 **SRR:** Substitute Remote Request bit
 When IDE = 0:
 1 = Message will request remote transmission
 0 = Normal message
 When IDE = 1:
 The SRR bit must be set to '1'.
- bit 0 **IDE:** Extended Identifier bit
 1 = Message will transmit an Extended Identifier
 0 = Message will transmit a Standard Identifier

BUFFER 21-2: CANx MESSAGE BUFFER WORD 1

U-0	U-0	U-0	U-0	R/W-x	R/W-x	R/W-x	R/W-x
—	—	—	—	EID<17:14>			
bit 15							bit 8

R/W-x	R/W-x	R/W-x	R/W-x	R/W-x	R/W-x	R/W-x	R/W-x
EID<13:6>							
bit 7							bit 0

Legend:

R = Readable bit	W = Writable bit	U = Unimplemented bit, read as '0'
-n = Value at POR	'1' = Bit is set	'0' = Bit is cleared
		x = Bit is unknown

- bit 15-12 **Unimplemented:** Read as '0'
- bit 11-0 **EID<17:6>:** Extended Identifier bits

dsPIC33EPXXXGM3XX/6XX/7XX

BUFFER 21-3: CANx MESSAGE BUFFER WORD 2

R/W-x	R/W-x	R/W-x	R/W-x	R/W-x	R/W-x	R/W-x	R/W-x
EID5	EID4	EID3	EID2	EID1	EID0	RTR	RB1
bit 15							bit 8

U-x	U-x	U-x	R/W-x	R/W-x	R/W-x	R/W-x	R/W-x
—	—	—	RB0	DLC3	DLC2	DLC1	DLC0
bit 7							bit 0

Legend:			
R = Readable bit	W = Writable bit	U = Unimplemented bit, read as '0'	
-n = Value at POR	'1' = Bit is set	'0' = Bit is cleared	x = Bit is unknown

- bit 15-10 **EID<5:0>**: Extended Identifier bits
- bit 9 **RTR**: Remote Transmission Request bit
 When **IDE = 1**:
 1 = Message will request remote transmission
 0 = Normal message
 When **IDE = 0**:
 The RTR bit is ignored.
- bit 8 **RB1**: Reserved Bit 1
 User must set this bit to '0' per CAN protocol.
- bit 7-5 **Unimplemented**: Read as '0'
- bit 4 **RB0**: Reserved Bit 0
 User must set this bit to '0' per CAN protocol.
- bit 3-0 **DLC<3:0>**: Data Length Code bits

BUFFER 21-4: CANx MESSAGE BUFFER WORD 3

R/W-x	R/W-x	R/W-x	R/W-x	R/W-x	R/W-x	R/W-x	R/W-x
Byte 1<15:8>							
bit 15							bit 8

R/W-x	R/W-x	R/W-x	R/W-x	R/W-x	R/W-x	R/W-x	R/W-x
Byte 0<7:0>							
bit 7							bit 0

Legend:			
R = Readable bit	W = Writable bit	U = Unimplemented bit, read as '0'	
-n = Value at POR	'1' = Bit is set	'0' = Bit is cleared	x = Bit is unknown

- bit 15-8 **Byte 1<15:8>**: CANx Message Byte 1
- bit 7-0 **Byte 0<7:0>**: CANx Message Byte 0

dsPIC33EPXXXGM3XX/6XX/7XX

BUFFER 21-5: CANx MESSAGE BUFFER WORD 4

R/W-x	R/W-x	R/W-x	R/W-x	R/W-x	R/W-x	R/W-x	R/W-x
Byte 3<15:8>							
bit 15				bit 8			

R/W-x	R/W-x	R/W-x	R/W-x	R/W-x	R/W-x	R/W-x	R/W-x
Byte 2<7:0>							
bit 7				bit 0			

Legend:

R = Readable bit W = Writable bit U = Unimplemented bit, read as '0'
-n = Value at POR '1' = Bit is set '0' = Bit is cleared x = Bit is unknown

bit 15-8 **Byte 3<15:8>**: CANx Message Byte 3

bit 7-0 **Byte 2<7:0>**: CANx Message Byte 2

BUFFER 21-6: CANx MESSAGE BUFFER WORD 5

R/W-x	R/W-x	R/W-x	R/W-x	R/W-x	R/W-x	R/W-x	R/W-x
Byte 5<15:8>							
bit 15				bit 8			

R/W-x	R/W-x	R/W-x	R/W-x	R/W-x	R/W-x	R/W-x	R/W-x
Byte 4<7:0>							
bit 7				bit 0			

Legend:

R = Readable bit W = Writable bit U = Unimplemented bit, read as '0'
-n = Value at POR '1' = Bit is set '0' = Bit is cleared x = Bit is unknown

bit 15-8 **Byte 5<15:8>**: CANx Message Byte 5

bit 7-0 **Byte 4<7:0>**: CANx Message Byte 4

BUFFER 21-7: CANx MESSAGE BUFFER WORD 6

R/W-x	R/W-x	R/W-x	R/W-x	R/W-x	R/W-x	R/W-x	R/W-x
Byte 7<15:8>							
bit 15							bit 8

R/W-x	R/W-x	R/W-x	R/W-x	R/W-x	R/W-x	R/W-x	R/W-x
Byte 6<7:0>							
bit 7							bit 0

Legend:			
R = Readable bit	W = Writable bit	U = Unimplemented bit, read as '0'	
-n = Value at POR	'1' = Bit is set	'0' = Bit is cleared	x = Bit is unknown

bit 15-8 **Byte 7<15:8>**: CANx Message Byte 7

bit 7-0 **Byte 6<7:0>**: CANx Message Byte 6

BUFFER 21-8: CANx MESSAGE BUFFER WORD 7

U-0	U-0	U-0	R/W-x	R/W-x	R/W-x	R/W-x	R/W-x
—	—	—	FILHIT<4:0> ⁽¹⁾				
bit 15							bit 8

U-0	U-0	U-0	U-0	U-0	U-0	U-0	U-0
—	—	—	—	—	—	—	—
bit 7							bit 0

Legend:			
R = Readable bit	W = Writable bit	U = Unimplemented bit, read as '0'	
-n = Value at POR	'1' = Bit is set	'0' = Bit is cleared	x = Bit is unknown

bit 15-13 **Unimplemented:** Read as '0'

bit 12-8 **FILHIT<4:0>**: Filter Hit Code bits⁽¹⁾
 Encodes number of filter that resulted in writing this buffer.

bit 7-0 **Unimplemented:** Read as '0'

Note 1: Only written by module for receive buffers, unused for transmit buffers.

dsPIC33EPXXGM3XX/6XX/7XX

NOTES:

22.0 CHARGE TIME MEASUREMENT UNIT (CTMU)

Note 1: This data sheet summarizes the features of the dsPIC33EPXXXGM3XX/6XX/7XX family of devices. It is not intended to be a comprehensive reference source. To complement the information in this data sheet, refer to the “dsPIC33/PIC24 Family Reference Manual”, “**Charge Time Measurement Unit (CTMU)**” (DS70661), which is available on the Microchip web site (www.microchip.com).

2: Some registers and associated bits described in this section may not be available on all devices. Refer to [Section 4.0 “Memory Organization”](#) in this data sheet for device-specific register and bit information.

The Charge Time Measurement Unit is a flexible analog module that provides accurate differential time measurement between pulse sources, as well as asynchronous pulse generation. Its key features include:

- Four edge input trigger sources
- Polarity control for each edge source
- Control of edge sequence
- Control of response to edges
- Precise time measurement resolution of 1 ns
- Accurate current source suitable for capacitive measurement
- On-chip temperature measurement using a built-in diode

Together with other on-chip analog modules, the CTMU can be used to precisely measure time, measure capacitance, measure relative changes in capacitance or generate output pulses that are independent of the system clock.

The CTMU module is ideal for interfacing with capacitive-based sensors. The CTMU is controlled through three registers: CTMUCON1, CTMUCON2 and CTMUICON. CTMUCON1 and CTMUCON2 enable the module and control edge source selection, edge source polarity selection and edge sequencing. The CTMUICON register controls the selection and trim of the current source.

dsPIC33EPXXXGM3XX/6XX/7XX

FIGURE 22-1: CTMU BLOCK DIAGRAM

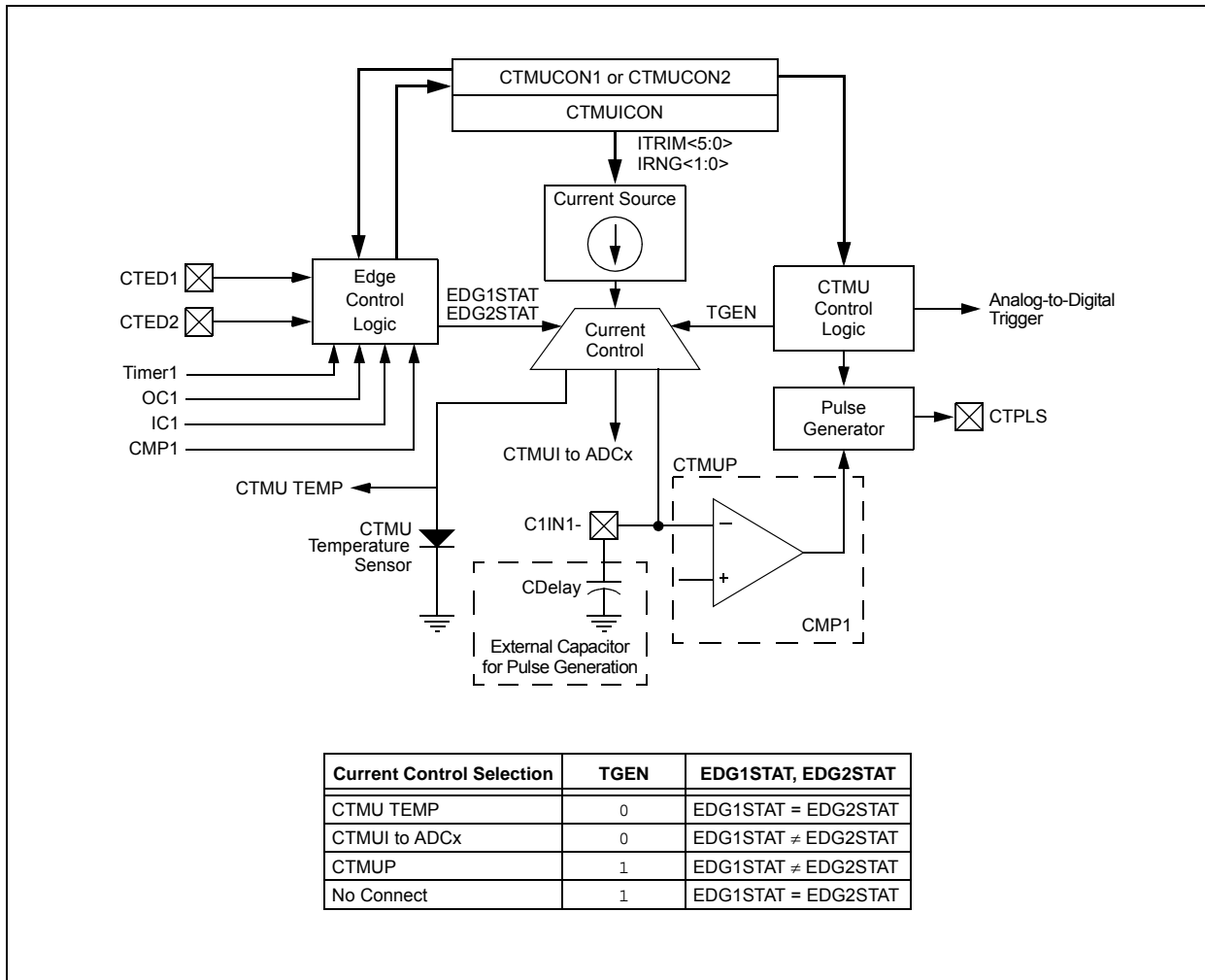

22.1 CTMU Control Registers

REGISTER 22-1: CTMUCON1: CTMU CONTROL REGISTER 1

R/W-0	U-0	R/W-0	R/W-0	R/W-0	R/W-0	R/W-0	R/W-0
CTMUEN	—	CTMUSIDL	TGEN	EDGEN	EDGSEQEN	IDISSEN ⁽¹⁾	CTTRIG
bit 15							bit 8
U-0	U-0	U-0	U-0	U-0	U-0	U-0	U-0
—	—	—	—	—	—	—	—
bit 7							bit 0

Legend:

R = Readable bit	W = Writable bit	U = Unimplemented bit, read as '0'	
-n = Value at POR	'1' = Bit is set	'0' = Bit is cleared	x = Bit is unknown

- bit 15 **CTMUEN:** CTMU Enable bit
 1 = Module is enabled
 0 = Module is disabled
- bit 14 **Unimplemented:** Read as '0'
- bit 13 **CTMUSIDL:** CTMU Stop in Idle Mode bit
 1 = Discontinues module operation when device enters Idle mode
 0 = Continues module operation in Idle mode
- bit 12 **TGEN:** Time Generation Enable bit
 1 = Enables edge delay generation
 0 = Disables edge delay generation
- bit 11 **EDGEN:** Edge Enable bit
 1 = Hardware modules are used to trigger edges (TMRx, CTEDx, etc.)
 0 = Software is used to trigger edges (manual set of EDGxSTAT)
- bit 10 **EDGSEQEN:** Edge Sequence Enable bit
 1 = Edge 1 event must occur before Edge 2 event can occur
 0 = No edge sequence is needed
- bit 9 **IDISSEN:** Analog Current Source Control bit⁽¹⁾
 1 = Analog current source output is grounded
 0 = Analog current source output is not grounded
- bit 8 **CTTRIG:** ADCx Trigger Control bit
 1 = CTMU triggers ADCx start of conversion
 0 = CTMU does not trigger ADCx start of conversion
- bit 7-0 **Unimplemented:** Read as '0'

Note 1: The ADCx module Sample-and-Hold (S&H) capacitor is not automatically discharged between sample/conversion cycles. Any software using the ADCx as part of a capacitance measurement must discharge the ADCx capacitor before conducting the measurement. The IDISSEN bit, when set to '1', performs this function. The ADCx must be sampling while the IDISSEN bit is active to connect the discharge sink to the capacitor array.

dsPIC33EPXXXGM3XX/6XX/7XX

REGISTER 22-2: CTMUCON2: CTMU CONTROL REGISTER 2

R/W-0	R/W-0	R/W-0	R/W-0	R/W-0	R/W-0	R/W-0	R/W-0
EDG1MOD	EDG1POL	EDG1SEL3	EDG1SEL2	EDG1SEL1	EDG1SEL0	EDG2STAT	EDG1STAT
bit 15						bit 8	

R/W-0	R/W-0	R/W-0	R/W-0	R/W-0	R/W-0	U-0	U-0
EDG2MOD	EDG2POL	EDG2SEL3	EDG2SEL2	EDG2SEL1	EDG2SEL0	—	—
bit 7						bit 0	

Legend:

R = Readable bit

W = Writable bit

U = Unimplemented bit, read as '0'

-n = Value at POR

'1' = Bit is set

'0' = Bit is cleared

x = Bit is unknown

bit 15 **EDG1MOD:** Edge 1 Edge Sampling Mode Selection bit

1 = Edge 1 is edge-sensitive

0 = Edge 1 is level-sensitive

bit 14 **EDG1POL:** Edge 1 Polarity Select bit

1 = Edge 1 is programmed for a positive edge response

0 = Edge 1 is programmed for a negative edge response

bit 13-10 **EDG1SEL<3:0>:** Edge 1 Source Select bits

1111 = FOSC

1110 = OSCI pin

1101 = FRC oscillator

1100 = Reserved

1011 = Internal LPRC oscillator

1010 = Reserved

100x = Reserved

01xx = Reserved

0011 = CTED1 pin

0010 = CTED2 pin

0001 = OC1 module

0000 = Timer1 module

bit 9 **EDG2STAT:** Edge 2 Status bit

Indicates the status of Edge 2 and can be written to control the edge source.

1 = Edge 2 has occurred

0 = Edge 2 has not occurred

bit 8 **EDG1STAT:** Edge 1 Status bit

Indicates the status of Edge 1 and can be written to control the edge source.

1 = Edge 1 has occurred

0 = Edge 1 has not occurred

bit 7 **EDG2MOD:** Edge 2 Edge Sampling Mode Selection bit

1 = Edge 2 is edge-sensitive

0 = Edge 2 is level-sensitive

bit 6 **EDG2POL:** Edge 2 Polarity Select bit

1 = Edge 2 is programmed for a positive edge response

0 = Edge 2 is programmed for a negative edge response

Note 1: If the TGEN bit is set to '1', then the CMP1 module should be selected as the Edge 2 source in the EDG2SELx bits field; otherwise, the module will not function.

REGISTER 22-2: CTMUCON2: CTMU CONTROL REGISTER 2 (CONTINUED)

bit 5-2 **EDG2SEL<3:0>**: Edge 2 Source Select bits

1111 = FOSC
1110 = OSCI pin
1101 = FRC oscillator
1100 = Reserved
1011 = Internal LPRC oscillator
1010 = Reserved
100x = Reserved
0111 = Reserved
0110 = Reserved
0101 = Reserved
0100 = CMP1 module⁽¹⁾
0011 = CTED2 pin
0010 = CTED1 pin
0001 = OC1 module
0000 = IC1 module

bit 1-0 **Unimplemented**: Read as '0'

Note 1: If the TGEN bit is set to '1', then the CMP1 module should be selected as the Edge 2 source in the EDG2SELx bits field; otherwise, the module will not function.

dsPIC33EPXXXGM3XX/6XX/7XX

REGISTER 22-3: CTMUICON: CTMU CURRENT CONTROL REGISTER⁽³⁾

R/W-0	R/W-0	R/W-0	R/W-0	R/W-0	R/W-0	R/W-0	R/W-0
ITRIM5	ITRIM4	ITRIM3	ITRIM2	ITRIM1	ITRIM0	IRNG1	IRNG0
bit 15							bit 8

U-0	U-0	U-0	U-0	U-0	U-0	U-0	U-0
—	—	—	—	—	—	—	—
bit 7							bit 0

Legend:

R = Readable bit W = Writable bit U = Unimplemented bit, read as '0'
 -n = Value at POR '1' = Bit is set '0' = Bit is cleared x = Bit is unknown

bit 15-10 **ITRIM<5:0>**: Current Source Trim bits
 011111 = Maximum positive change from nominal current + 62%
 011110 = Maximum positive change from nominal current + 60%
 •
 •
 •
 000010 = Minimum positive change from nominal current + 4%
 000001 = Minimum positive change from nominal current + 2%
 000000 = Nominal current output specified by IRNG<1:0>
 111111 = Minimum negative change from nominal current – 2%
 111110 = Minimum negative change from nominal current – 4%
 •
 •
 •
 100010 = Maximum negative change from nominal current – 60%
 100001 = Maximum negative change from nominal current – 62%

bit 9-8 **IRNG<1:0>**: Current Source Range Select bits
 11 = 100 × Base Current⁽²⁾
 10 = 10 × Base Current⁽²⁾
 01 = Base Current Level⁽²⁾
 00 = 1000 × Base Current^(1,2)

bit 7-0 **Unimplemented**: Read as '0'

- Note 1:** This current range is not available for use with the internal temperature measurement diode.
Note 2: Refer to the CTMU Current Source Specifications (Table 33-55) in Section 33.0 “Electrical Characteristics” for the current range selection values.
Note 3: Current sources are not generated when 12-Bit ADC mode is chosen. Current sources are active only when 10-Bit ADC mode is chosen.

23.0 10-BIT/12-BIT ANALOG-TO-DIGITAL CONVERTER (ADC)

Note 1: This data sheet summarizes the features of the dsPIC33EPXXXGM3XX/6XX/7XX family of devices. It is not intended to be a comprehensive reference source. To complement the information in this data sheet, refer to the “dsPIC33/PIC24 Family Reference Manual”, “Analog-to-Digital Converter (ADC)” (DS70621), which is available from the Microchip web site (www.microchip.com).

2: Some registers and associated bits described in this section may not be available on all devices. Refer to [Section 4.0 “Memory Organization”](#) in this data sheet for device-specific register and bit information.

The dsPIC33EPXXXGM3XX/6XX/7XX devices have two ADC modules: ADC1 and ADC2. The ADC1 supports up to 49 analog input channels, while the ADC2 supports up to 32 analog input channels.

On ADCx, the AD12B bit (ADxCON1<10>) allows each of the ADC modules to be configured by the user as either a 10-bit, 4 Sample-and-Hold (S&H) ADC (default configuration) or a 12-bit, 1 S&H ADC. Both ADC1 and ADC2 can be operated in 12-bit mode.

Note: The ADCx module needs to be disabled before modifying the AD12B bit.

23.1 Key Features

23.1.1 10-BIT ADCx CONFIGURATION

The 10-bit ADCx configuration has the following key features:

- Successive Approximation (SAR) conversion
- Conversion speeds of up to 1.1 Msps
- Up to 49 analog input pins
- Connections to three internal op amps
- Connections to the Charge Time Measurement Unit (CTMU) and temperature measurement diode

- Channel selection and triggering can be controlled by the Peripheral Trigger Generator (PTG)
- External voltage reference input pins
- Simultaneous sampling of:
 - Up to four analog input pins
 - Three op amp outputs
- Combinations of analog inputs and op amp outputs
- Automatic Channel Scan mode
- Selectable conversion trigger source
- Selectable Buffer Fill modes
- Four result alignment options (signed/unsigned, fractional/integer)
- Operation during CPU Sleep and Idle modes

23.1.2 12-BIT ADCx CONFIGURATION

The 12-bit ADCx configuration supports all the features listed above, with the exception of the following:

- In the 12-bit configuration, conversion speeds of up to 500 ksps are supported
- There is only one S&H amplifier in the 12-bit configuration; therefore, simultaneous sampling of multiple channels is not supported.
- Analog inputs, AN32-AN49, are not supported

The ADC1 has up to 49 analog inputs. The analog inputs, AN32 through AN49, are multiplexed, thus providing flexibility in using any of these analog inputs in addition to the analog inputs, AN0 through AN31. Since AN32 through AN49 are multiplexed, do not use two channels simultaneously, since it may result in erroneous output from the module. These analog inputs are shared with op amp inputs and outputs, comparator inputs and external voltage references. When op amp/comparator functionality is enabled, or an external voltage reference is used, the analog input that shares that pin is no longer available. The actual number of analog input pins, op amps and external voltage reference input configuration, depends on the specific device.

A block diagram of the ADCx module is shown in [Figure 23-1](#). [Figure 23-2](#) provides a diagram of the ADCx conversion clock period.

FIGURE 23-1: ADCx MODULE BLOCK DIAGRAM WITH CONNECTION OPTIONS FOR ANx PINS AND OP AMPS

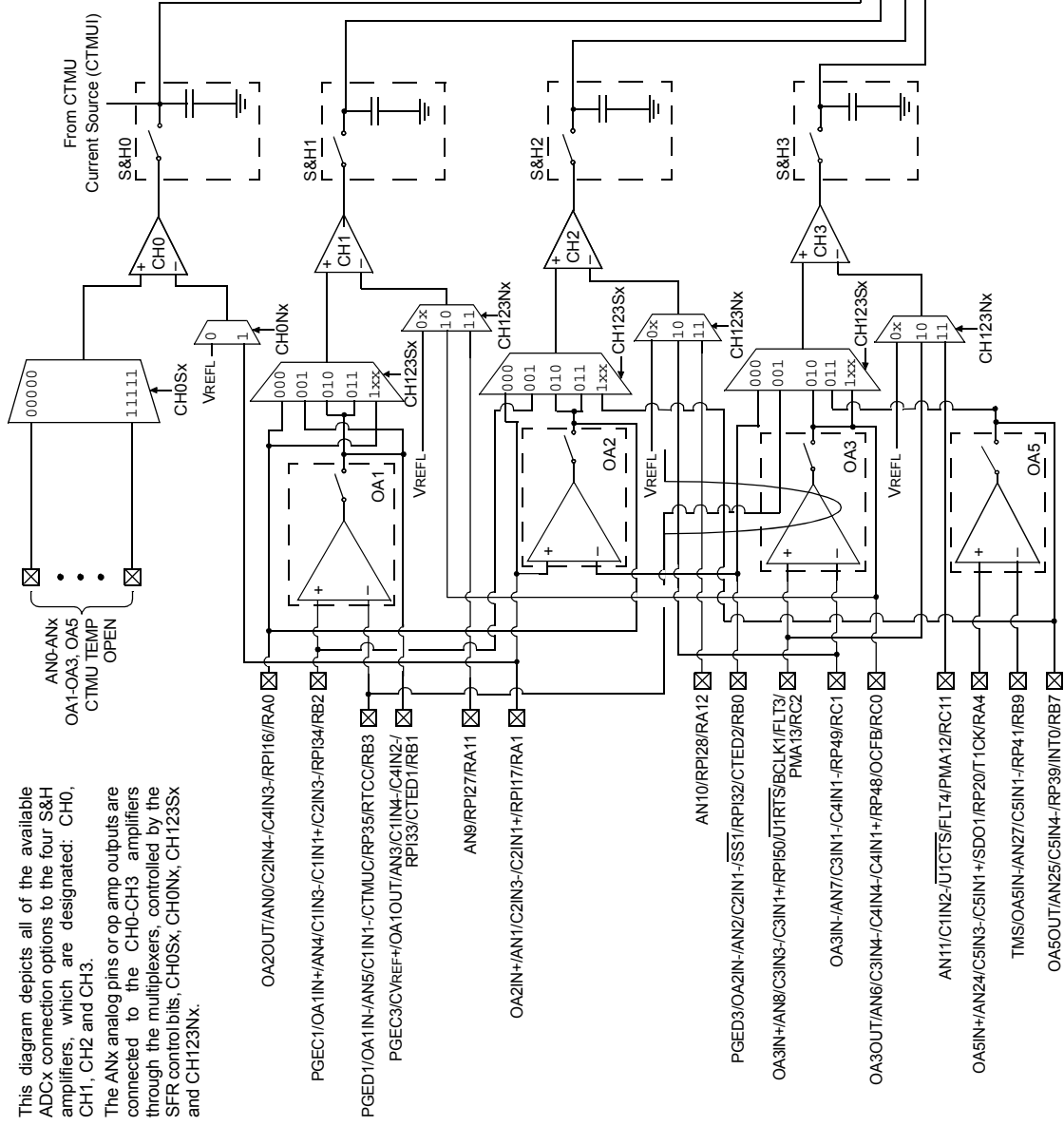

This diagram depicts all of the available ADCx connection options to the four S&H amplifiers, which are designated: CH0, CH1, CH2 and CH3. The ANx analog pins or op amp outputs are connected to the CH0-CH3 amplifiers through the multiplexers, controlled by the SFR control bits: CH0Sx, CH0Nx, CH123Sx and CH123Nx.

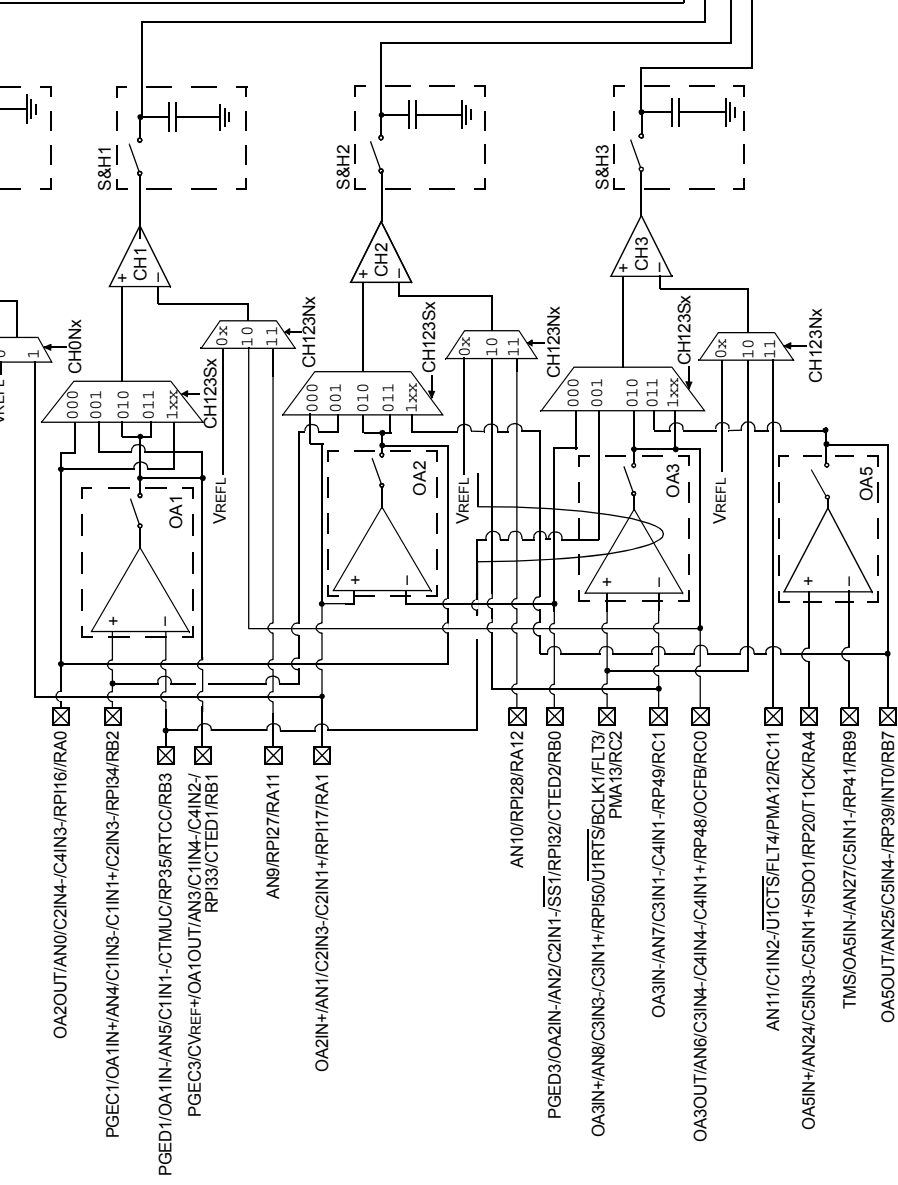

Note 1: VREF+, VREF- inputs can be multiplexed with other analog inputs.

Note 2: Channels 1, 2 and 3 are not applicable for the 12-bit mode of operation.

Note 3: These bits can be updated with Step commands from the PTG module. For more information, refer to the "Peripheral Trigger Generator (PTG)" chapter in the specification.

Note 4: When ADDMAEN (ADxCON4<8>) = 1, enabling DMA, only ADCxBUF0 is used.

FIGURE 23-2: ADCx CONVERSION CLOCK PERIOD BLOCK DIAGRAM

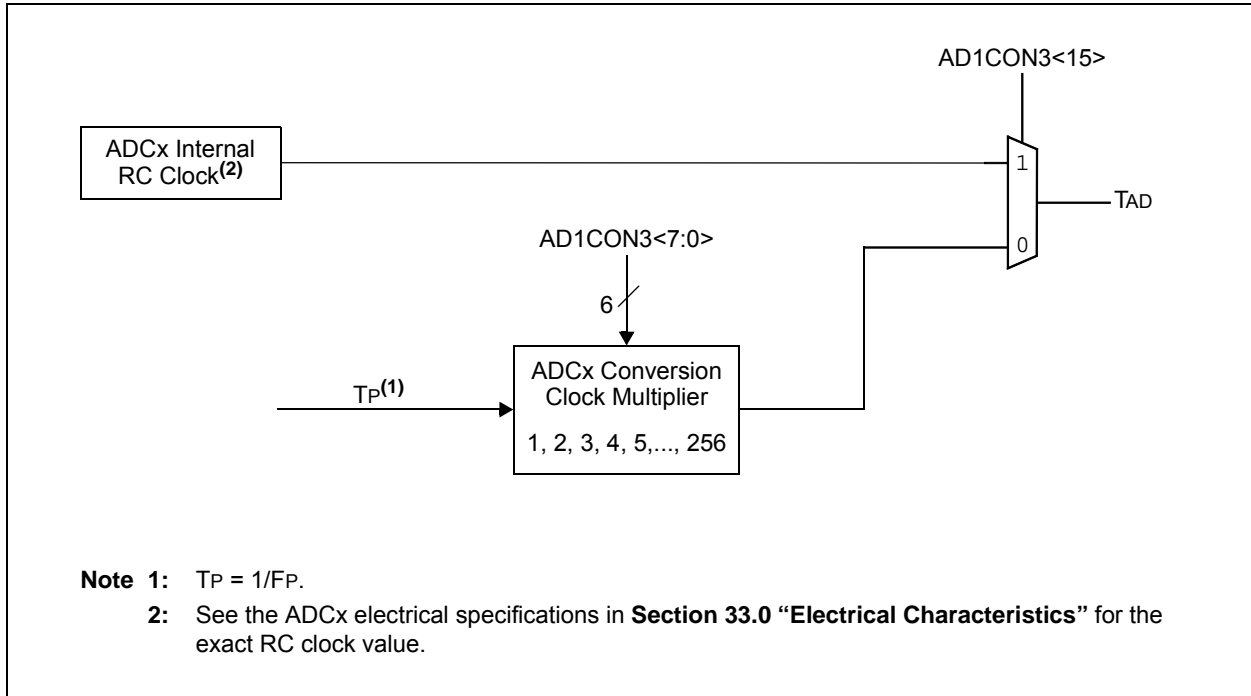

23.2 ADCx Helpful Tips

1. The SMP1x control bits in the ADxCON2 registers:
 - a) Determine when the ADCx interrupt flag is set and an interrupt is generated, if enabled.
 - b) When the CSCNA bit in the ADxCON2 register is set to '1', this determines when the ADCx analog scan channel list, defined in the AD1CSSL/AD1CSSH registers, starts over from the beginning.
 - c) When the DMA peripheral is not used (ADDMAEN = 0), this determines when the ADCx Result Buffer Pointer to ADC1BUF0-ADC1BUFF gets reset back to the beginning at ADC1BUF0.
 - d) When the DMA peripheral is used (ADDMAEN = 1), this determines when the DMA Address Pointer is incremented after a sample/conversion operation. ADC1BUF0 is the only ADCx buffer used in this mode. The ADCx Result Buffer Pointer to ADC1BUF0-ADC1BUFF gets reset back to the beginning at ADC1BUF0. The DMA address is incremented after completion of every 32nd sample/conversion operation. Conversion results are stored in the ADC1BUF0 register for transfer to RAM using the DMA peripheral.
2. When the DMA module is disabled (ADDMAEN = 0), the ADCx has 16 result buffers. ADCx conversion results are stored sequentially in ADC1BUF0-ADC1BUFF, regardless of which analog inputs are being used subject to the SMP1x bits and the condition described in 1.c) above. There is no relationship between the ANx input being measured and which ADCx buffer (ADC1BUF0-ADC1BUFF) that the conversion results will be placed in.
3. When the DMA module is enabled (ADDMAEN = 1), the ADCx module has only 1 ADCx result buffer (i.e., ADC1BUF0) per ADCx peripheral and the ADCx conversion result must be read, either by the CPU or DMA Controller, before the next ADCx conversion is complete to avoid overwriting the previous value.
4. The DONE bit (ADxCON1<0>) is only cleared at the start of each conversion and is set at the completion of the conversion, but remains set indefinitely, even through the next sample phase until the next conversion begins. If application code is monitoring the DONE bit in any kind of software loop, the user must consider this behavior because the CPU code execution is faster than the ADCx. As a result, in Manual Sample mode, particularly where the user's code is setting the SAMP bit (ADxCON1<1>), the DONE bit should also be cleared by the user application just before setting the SAMP bit.
5. Enabling op amps, comparator inputs and external voltage references can limit the availability of analog inputs (ANx pins). For example, when Op Amp 2 is enabled, the pins for AN0, AN1 and AN2 are used by the op amp's inputs and output. This negates the usefulness of Alternate Input mode since the MUXA selections use AN0-AN2. Carefully study the ADCx block diagram to determine the configuration that will best suit your application. Configuration examples are available in the "dsPIC33/PIC24 Family Reference Manual", "**Analog-to-Digital Converter (ADC)**" (DS70621)

23.3 ADCx Control Registers

REGISTER 23-1: ADxCON1: ADCx CONTROL REGISTER 1

R/W-0	U-0	R/W-0	R/W-0	U-0	R/W-0	R/W-0	R/W-0
ADON	—	ADSIDL	ADDMABM	—	AD12B	FORM1	FORM0
bit 15							bit 8

R/W-0	R/W-0	R/W-0	R/W-0	R/W-0	R/W-0	R/W-0, HC, HS	R/C-0, HC, HS
SSRC2	SSRC1	SSRC0	SSRCG	SIMSAM	ASAM	SAMP	DONE ⁽²⁾
bit 7							bit 0

Legend:	C = Clearable bit	U = Unimplemented bit, read as '0'	
R = Readable bit	W = Writable bit	HS = Hardware Settable bit	HC = Hardware Clearable bit
-n = Value at POR	'1' = Bit is set	'0' = Bit is cleared	x = Bit is unknown

- bit 15 **ADON:** ADCx Operating Mode bit
 1 = ADCx module is operating
 0 = ADCx is off
- bit 14 **Unimplemented:** Read as '0'
- bit 13 **ADSIDL:** ADCx Stop in Idle Mode bit
 1 = Discontinues module operation when device enters Idle mode
 0 = Continues module operation in Idle mode
- bit 12 **ADDMABM:** ADCx DMA Buffer Build Mode bit
 1 = DMA buffers are written in the order of conversion; the module provides an address to the DMA channel that is the same as the address used for the non-DMA stand-alone buffer
 0 = DMA buffers are written in Scatter/Gather mode; the module provides a Scatter/Gather address to the DMA channel based on the index of the analog input and the size of the DMA buffer
- bit 11 **Unimplemented:** Read as '0'
- bit 10 **AD12B:** 10-Bit or 12-Bit ADCx Operation Mode bit
 1 = 12-bit, 1-channel ADCx operation
 0 = 10-bit, 4-channel ADCx operation
- bit 9-8 **FORM<1:0>:** Data Output Format bits
 For 10-Bit Operation:
 11 = Signed fractional (DOUT = sddd dddd dd00 0000, where s = .NOT.d<9>)
 10 = Fractional (DOUT = dddd dddd dd00 0000)
 01 = Signed integer (DOUT = ssss sssd dddd dddd, where s = .NOT.d<9>)
 00 = Integer (DOUT = 0000 00dd dddd dddd)
 For 12-Bit Operation:
 11 = Signed fractional (DOUT = sddd dddd dddd 0000, where s = .NOT.d<11>)
 10 = Fractional (DOUT = dddd dddd dddd 0000)
 01 = Signed integer (DOUT = ssss sddd dddd dddd, where s = .NOT.d<11>)
 00 = Integer (DOUT = 0000 dddd dddd dddd)

Note 1: See Section 25.0 “Peripheral Trigger Generator (PTG) Module” for information on this selection.
Note 2: Do not clear the DONE bit in software if ADCx Sample Auto-Start bit is enabled (ASAM = 1).

dsPIC33EPXXXGM3XX/6XX/7XX

REGISTER 23-1: ADxCON1: ADCx CONTROL REGISTER 1 (CONTINUED)

- bit 7-5 **SSRC<2:0>**: Sample Clock Source Select bits
- If SSRCG = 1:
- 111 = Reserved
 - 110 = PTGO15 primary trigger compare ends sampling and starts conversion⁽¹⁾
 - 101 = PTGO14 primary trigger compare ends sampling and starts conversion⁽¹⁾
 - 100 = PTGO13 primary trigger compare ends sampling and starts conversion⁽¹⁾
 - 011 = PTGO12 primary trigger compare ends sampling and starts conversion⁽¹⁾
 - 010 = PWM Generator 3 primary trigger compare ends sampling and starts conversion
 - 001 = PWM Generator 2 primary trigger compare ends sampling and starts conversion
 - 000 = PWM Generator 1 primary trigger compare ends sampling and starts conversion
- If SSRCG = 0:
- 111 = Internal counter ends sampling and starts conversion (auto-convert)
 - 110 = CTMU ends sampling and starts conversion
 - 101 = PWM secondary Special Event Trigger ends sampling and starts conversion
 - 100 = Timer5 compare ends sampling and starts conversion
 - 011 = PWM primary Special Event Trigger ends sampling and starts conversion
 - 010 = Timer3 compare ends sampling and starts conversion
 - 001 = Active transition on the INT0 pin ends sampling and starts conversion
 - 000 = Clearing the Sample bit (SAMP) ends sampling and starts conversion (Manual mode)
- bit 4 **SSRCG**: Sample Trigger Source Group bit
See SSRC<2:0> for details.
- bit 3 **SIMSAM**: Simultaneous Sample Select bit (only applicable when CHPS<1:0> = 01 or 1x)
In 12-Bit Mode (AD12B = 1), SIMSAM is Unimplemented and is Read as '0':
- 1 = Samples CH0, CH1, CH2, CH3 simultaneously (when CHPS<1:0> = 1x), or samples CH0 and CH1 simultaneously (when CHPS<1:0> = 01)
 - 0 = Samples multiple channels individually in sequence
- bit 2 **ASAM**: ADCx Sample Auto-Start bit
- 1 = Sampling begins immediately after last conversion; SAMP bit is auto-set
 - 0 = Sampling begins when SAMP bit is set
- bit 1 **SAMP**: ADCx Sample Enable bit
- 1 = ADCx Sample-and-Hold amplifiers are sampling
 - 0 = ADCx Sample-and-Hold amplifiers are holding
- If ASAM = 0, software can write '1' to begin sampling. Automatically set by hardware if ASAM = 1. If SSRC<2:0> = 000, software can write '0' to end sampling and start conversion. If SSRC<2:0> ≠ 000, automatically cleared by hardware to end sampling and start conversion.
- bit 0 **DONE**: ADCx Conversion Status bit⁽²⁾
- 1 = ADCx conversion cycle is completed.
 - 0 = ADCx conversion has not started or is in progress
- Automatically set by hardware when A/D conversion is complete. Software can write '0' to clear DONE status (software not allowed to write '1'). Clearing this bit does NOT affect any operation in progress. Automatically cleared by hardware at the start of a new conversion.

Note 1: See Section 25.0 "Peripheral Trigger Generator (PTG) Module" for information on this selection.

2: Do not clear the DONE bit in software if ADCx Sample Auto-Start bit is enabled (ASAM = 1).

REGISTER 23-2: ADxCON2: ADCx CONTROL REGISTER 2

R/W-0	R/W-0	R/W-0	R/W-0	U-0	R/W-0	R/W-0	R/W-0
VCFG2 ⁽¹⁾	VCFG1 ⁽¹⁾	VCFG0 ⁽¹⁾	OFFCAL	—	CSCNA	CHPS1	CHPS0
bit 15							bit 8

R-0	R/W-0	R/W-0	R/W-0	R/W-0	R/W-0	R/W-0	R/W-0
BUFS	SMPI4	SMPI3	SMPI2	SMPI1	SMPI0	BUFM	ALTS
bit 7							bit 0

Legend:

R = Readable bit	W = Writable bit	U = Unimplemented bit, read as '0'
-n = Value at POR	'1' = Bit is set	'0' = Bit is cleared
		x = Bit is unknown

bit 15-13 **VCFG<2:0>**: Converter Voltage Reference Configuration bits⁽¹⁾

Value	VREFH	VREFL
000	AVDD	AVSS
001	External VREF+ ⁽²⁾	AVSS
010	AVDD	External VREF- ⁽²⁾
011	External VREF+ ⁽²⁾	External VREF- ⁽²⁾
1xx	AVDD	AVSS

bit 12 **OFFCAL**: Offset Calibration Mode Select bit
 1 = + and – inputs of channel Sample-and-Hold are connected to AVSS
 0 = + and – inputs of channel Sample-and-Hold are normal

bit 11 **Unimplemented**: Read as '0'

bit 10 **CSCNA**: Input Scan Select bit
 1 = Scans inputs for CH0+ during Sample MUXA
 0 = Does not scan inputs

bit 9-8 **CHPS<1:0>**: Channel Select bits
In 12-Bit Mode (AD12B = 1), CHPS<1:0> Bits are Unimplemented and are Read as '00':
 1x = Converts CH0, CH1, CH2 and CH3
 01 = Converts CH0 and CH1
 00 = Converts CH0

bit 7 **BUFS**: Buffer Fill Status bit (only valid when BUFM = 1)
 1 = ADCx is currently filling the second half of the buffer; the user application should access data in the first half of the buffer
 0 = ADCx is currently filling the first half of the buffer; the user application should access data in the second half of the buffer

Note 1: The '001', '010' and '011' bit combinations for VCFG<2:0> are not applicable on ADC2.

2: ADC2 does not support external VREF± inputs.

REGISTER 23-2: ADxCON2: ADCx CONTROL REGISTER 2 (CONTINUED)

bit 6-2 **SMPI<4:0>**: Increment Rate bits

When ADDMAEN = 0:

x1111 = Generates interrupt after completion of every 16th sample/conversion operation

x1110 = Generates interrupt after completion of every 15th sample/conversion operation

•

•

•

x0001 = Generates interrupt after completion of every 2nd sample/conversion operation

x0000 = Generates interrupt after completion of every sample/conversion operation

When ADDMAEN = 1:

11111 = Increments the DMA address after completion of every 32nd sample/conversion operation

11110 = Increments the DMA address after completion of every 31st sample/conversion operation

•

•

•

00001 = Increments the DMA address after completion of every 2nd sample/conversion operation

00000 = Increments the DMA address after completion of every sample/conversion operation

bit 1 **BUFm**: Buffer Fill Mode Select bit

1 = Starts buffer filling the first half of the buffer on the first interrupt and the second half of the buffer on the next interrupt

0 = Always starts filling the buffer from the Start address

bit 0 **ALTS**: Alternate Input Sample Mode Select bit

1 = Uses channel input selects for Sample MUXA on the first sample and Sample MUXB on the next sample

0 = Always uses channel input selects for Sample MUXA

Note 1: The '001', '010' and '011' bit combinations for VCFG<2:0> are not applicable on ADC2.

2: ADC2 does not support external VREF± inputs.

REGISTER 23-3: ADxCON3: ADCx CONTROL REGISTER 3

R/W-0	U-0	U-0	R/W-0	R/W-0	R/W-0	R/W-0	R/W-0
ADRC	—	—	SAMC4 ⁽¹⁾	SAMC3 ⁽¹⁾	SAMC2 ⁽¹⁾	SAMC1 ⁽¹⁾	SAMC0 ⁽¹⁾
bit 15							bit 8

R/W-0	R/W-0	R/W-0	R/W-0	R/W-0	R/W-0	R/W-0	R/W-0
ADCS7 ⁽²⁾	ADCS6 ⁽²⁾	ADCS5 ⁽²⁾	ADCS4 ⁽²⁾	ADCS3 ⁽²⁾	ADCS2 ⁽²⁾	ADCS1 ⁽²⁾	ADCS0 ⁽²⁾
bit 7							bit 0

Legend:			
R = Readable bit	W = Writable bit	U = Unimplemented bit, read as '0'	
-n = Value at POR	'1' = Bit is set	'0' = Bit is cleared	x = Bit is unknown

- bit 15 **ADRC:** ADCx Conversion Clock Source bit
 1 = ADCx internal RC clock
 0 = Clock derived from system clock
- bit 14-13 **Unimplemented:** Read as '0'
- bit 12-8 **SAMC<4:0>:** Auto-Sample Time bits⁽¹⁾
 11111 = 31 TAD
 •
 •
 •
 00001 = 1 TAD
 00000 = 0 TAD
- bit 7-0 **ADCS<7:0>:** ADCx Conversion Clock Select bits⁽²⁾
 11111111 = TP • (ADCS<7:0> + 1) = TP • 256 = TAD
 •
 •
 •
 00000010 = TP • (ADCS<7:0> + 1) = TP • 3 = TAD
 00000001 = TP • (ADCS<7:0> + 1) = TP • 2 = TAD
 00000000 = TP • (ADCS<7:0> + 1) = TP • 1 = TAD

Note 1: This bit is only used if SSRC<2:0> (AD1CON1<7:5>) = 111 and SSRCG (AD1CON1<4>) = 0.
2: This bit is not used if ADRC (AD1CON3<15>) = 1.

dsPIC33EPXXXGM3XX/6XX/7XX

REGISTER 23-4: ADxCON4: ADCx CONTROL REGISTER 4

U-0	U-0	U-0	U-0	U-0	U-0	U-0	R/W-0
—	—	—	—	—	—	—	ADDMAEN
bit 15							bit 8

U-0	U-0	U-0	U-0	U-0	R/W-0	R/W-0	R/W-0
—	—	—	—	—	DMABL2	DMABL1	DMABL0
bit 7						bit 0	

Legend:

R = Readable bit

W = Writable bit

U = Unimplemented bit, read as '0'

-n = Value at POR

'1' = Bit is set

'0' = Bit is cleared

x = Bit is unknown

bit 15-9

Unimplemented: Read as '0'

bit 8

ADDMAEN: ADCx DMA Enable bit

1 = Conversion results are stored in the ADC1BUF0 register for transfer to RAM using DMA

0 = Conversion results are stored in the ADC1BUF0 through ADC1BUFF registers; DMA will not be used

bit 7-3

Unimplemented: Read as '0'

bit 2-0

DMABL<2:0>: Selects Number of DMA Buffer Locations per Analog Input bits

111 = Allocates 128 words of buffer to each analog input

110 = Allocates 64 words of buffer to each analog input

101 = Allocates 32 words of buffer to each analog input

100 = Allocates 16 words of buffer to each analog input

011 = Allocates 8 words of buffer to each analog input

010 = Allocates 4 words of buffer to each analog input

001 = Allocates 2 words of buffer to each analog input

000 = Allocates 1 word of buffer to each analog input

REGISTER 23-5: ADxCHS123: ADCx INPUT CHANNEL 1, 2, 3 SELECT REGISTER

U-0	U-0	U-0	R/W-0	R/W-0	R/W-0	R/W-0	R/W-0
—	—	—	CH123SB2	CH123SB1	CH123NB1	CH123NB0	CH123SB0
bit 15							bit 8

U-0	U-0	U-0	R/W-0	R/W-0	R/W-0	R/W-0	R/W-0
—	—	—	CH123SA2	CH123SA1	CH123NA1	CH123NA0	CH123SA0
bit 7							bit 0

Legend:

R = Readable bit	W = Writable bit	U = Unimplemented bit, read as '0'
-n = Value at POR	'1' = Bit is set	'0' = Bit is cleared x = Bit is unknown

- bit 15-13 **Unimplemented:** Read as '0'
- bit 12-11 **CH123SB<2:1>:** Channels 1, 2, 3 Positive Input Select for Sample B bits
 - 1xx = CH1 positive input is AN0 (Op Amp 2), CH2 positive input is AN25 (Op Amp 5), CH3 positive input is AN6 (Op Amp 3)
 - 011 = CH1 positive input is AN3 (Op Amp 1), CH2 positive input is AN0 (Op Amp 2), CH3 positive input is AN25 (Op Amp 5)
 - 010 = CH1 positive input is AN3 (Op Amp 1), CH2 positive input is AN0 (Op Amp 2), CH3 positive input is AN6 (Op Amp 3)
 - 001 = CH1 positive input is AN3, CH2 positive input is AN4, CH3 positive input is AN5
 - 000 = CH1 positive input is AN0, CH2 positive input is AN1, CH3 positive input is AN2
- bit 10-9 **CH123NB<1:0>:** Channels 1, 2, 3 Negative Input Select for Sample B bits
 - 11 = CH1 negative input is AN9, CH2 negative input is AN10, CH3 negative input is AN11
 - 10 = CH1 negative input is AN6, CH2 negative input is AN7, CH3 negative input is AN8
 - 0x = CH1, CH2, CH3 negative input is VREFL⁽¹⁾
- bit 8 **CH123SB0:** Channels 1, 2, 3 Positive Input Select for Sample B bit
See bits<12:11> for bit selections.
- bit 7-5 **Unimplemented:** Read as '0'
- bit 4-3 **CH123SA<2:1>:** Channels 1, 2, 3 Positive Input Select for Sample A bits
 - 1xx = CH1 positive input is AN0 (Op Amp 2), CH2 positive input is AN25 (Op Amp 5), CH3 positive input is AN6 (Op Amp 3)
 - 011 = CH1 positive input is AN3 (Op Amp 1), CH2 positive input is AN0 (Op Amp 2), CH3 positive input is AN25 (Op Amp 5)
 - 010 = CH1 positive input is AN3 (Op Amp 1), CH2 positive input is AN0 (Op Amp 2), CH3 positive input is AN6 (Op Amp 3)
 - 001 = CH1 positive input is AN3, CH2 positive input is AN4, CH3 positive input is AN5
 - 000 = CH1 positive input is AN0, CH2 positive input is AN1, CH3 positive input is AN2
- bit 2-1 **CH123NA<1:0>:** Channels 1, 2, 3 Negative Input Select for Sample A bits
 - 11 = CH1 negative input is AN9, CH2 negative input is AN10, CH3 negative input is AN11
 - 10 = CH1 negative input is AN6, CH2 negative input is AN7, CH3 negative input is AN8
 - 0x = CH1, CH2, CH3 negative input is VREFL
- bit 0 **CH123SA0:** Channels 1, 2, 3 Positive Input Select for Sample A bit
See bits<4:3> for the bit selections.

Note 1: The negative input to VREFL happens only when VCFG<2:0> = 2 or 3 in the ADxCON2 register. When VCFG<2:0> = 0 or 1, this negative input is internally routed to AVss.

dsPIC33EPXXXGM3XX/6XX/7XX

REGISTER 23-6: ADxCHS0: ADCx INPUT CHANNEL 0 SELECT REGISTER⁽³⁾

R/W-0	U-0	R/W-0	R/W-0	R/W-0	R/W-0	R/W-0	R/W-0
CH0NB	—	CH0SB5 ^(1,4,5)	CH0SB4 ^(1,5)	CH0SB3 ^(1,5)	CH0SB2 ^(1,5)	CH0SB1 ^(1,5)	CH0SB0 ^(1,5)
bit 15							bit 8

R/W-0	U-0	R/W-0	R/W-0	R/W-0	R/W-0	R/W-0	R/W-0
CH0NA	—	CH0SA5 ^(1,4,5)	CH0SA4 ^(1,5)	CH0SA3 ^(1,5)	CH0SA2 ^(1,5)	CH0SA1 ^(1,5)	CH0SA0 ^(1,5)
bit 7							bit 0

Legend:							
R = Readable bit	W = Writable bit	U = Unimplemented bit, read as '0'					
-n = Value at POR	'1' = Bit is set	'0' = Bit is cleared	x = Bit is unknown				

- bit 15 **CH0NB:** Channel 0 Negative Input Select for Sample MUXB bit
 1 = Channel 0 negative input is AN1⁽¹⁾
 0 = Channel 0 negative input is VREFL
- bit 14 **Unimplemented:** Read as '0'
- bit 13-8 **CH0SB<5:0>:** Channel 0 Positive Input Select for Sample MUXB bits^(1,4,5)
 111111 = Channel 0 positive input is (AN63) unconnected
 111110 = Channel 0 positive input is (AN62) the CTMU temperature voltage
 111101 = Channel 0 positive input is (AN61) reserved
 .
 .
 .
 110010 = Channel 0 positive input is (AN50) reserved
 110001 = Channel 0 positive input is AN49
 110000 = Channel 0 positive input is AN48
 101111 = Channel 0 positive input is AN47
 101110 = Channel 0 positive input is AN46
 .
 .
 .
 011010 = Channel 0 positive input is AN26
 011001 = Channel 0 positive input is AN25 or Op Amp 5 output voltage⁽²⁾
 011000 = Channel 0 positive input is AN24
 .
 .
 .
 000111 = Channel 0 positive input is AN7
 000110 = Channel 0 positive input is AN6 or Op Amp 3 output voltage⁽²⁾
 000101 = Channel 0 positive input is AN5
 000100 = Channel 0 positive input is AN4
 000011 = Channel 0 positive input is AN3 or Op Amp 1 output voltage⁽²⁾
 000010 = Channel 0 positive input is AN2
 000001 = Channel 0 positive input is AN1
 000000 = Channel 0 positive input is AN0 or Op Amp 2 output voltage⁽²⁾

- Note 1:** AN0 through AN7 are repurposed when comparator and op amp functionality are enabled. See [Figure 23-1](#) to determine how enabling a particular op amp or comparator affects selection choices for Channels 1, 2 and 3.
- 2:** If the op amp is selected (OPMODE bit (CMxCON<10>) = 1), the OAx input is used; otherwise, the ANx input is used.
- 3:** See the **“Pin Diagrams”** section for the available analog channels for each device.
- 4:** Analog input selections for ADC1 are shown here. AN32-AN63 selections are not available for ADC2. The CH0SB5 and CH0SA5 bits are 'Reserved' for ADC2 and should be programmed to '0'.
- 5:** Analog inputs, AN32-AN49, are available only when the ADCx is working in 10-bit mode.

REGISTER 23-6: ADxCHS0: ADCx INPUT CHANNEL 0 SELECT REGISTER⁽³⁾ (CONTINUED)

bit 7	CH0NA: Channel 0 Negative Input Select for Sample MUXA bit 1 = Channel 0 negative input is AN1 ⁽¹⁾ 0 = Channel 0 negative input is VREFL
bit 6	Unimplemented: Read as '0'
bit 5-0	CH0SA<5:0>: Channel 0 Positive Input Select for Sample MUXA bits ^(1,4,5) 111111 = Channel 0 positive input is (AN63) unconnected 111110 = Channel 0 positive input is (AN62) the CTMU temperature voltage 111101 = Channel 0 positive input is (AN61) reserved . . . 110010 = Channel 0 positive input is (AN50) reserved 110001 = Channel 0 positive input is AN49 110000 = Channel 0 positive input is AN48 101111 = Channel 0 positive input is AN47 101110 = Channel 0 positive input is AN46 . . . 011010 = Channel 0 positive input is AN26 011001 = Channel 0 positive input is AN25 or Op Amp 5 output voltage ⁽²⁾ 011000 = Channel 0 positive input is AN24 . . . 000111 = Channel 0 positive input is AN7 000110 = Channel 0 positive input is AN6 or Op Amp 3 output voltage ⁽²⁾ 000101 = Channel 0 positive input is AN5 000100 = Channel 0 positive input is AN4 000011 = Channel 0 positive input is AN3 or Op Amp 1 output voltage ⁽²⁾ 000010 = Channel 0 positive input is AN2 000001 = Channel 0 positive input is AN1 000000 = Channel 0 positive input is AN0 or Op Amp 2 output voltage ⁽²⁾

- Note 1:** AN0 through AN7 are repurposed when comparator and op amp functionality are enabled. See [Figure 23-1](#) to determine how enabling a particular op amp or comparator affects selection choices for Channels 1, 2 and 3.
- 2:** If the op amp is selected (OPMODE bit (CMxCON<10>) = 1), the OAx input is used; otherwise, the ANx input is used.
- 3:** See the **“Pin Diagrams”** section for the available analog channels for each device.
- 4:** Analog input selections for ADC1 are shown here. AN32-AN63 selections are not available for ADC2. The CH0SB5 and CH0SA5 bits are 'Reserved' for ADC2 and should be programmed to '0'.
- 5:** Analog inputs, AN32-AN49, are available only when the ADCx is working in 10-bit mode.

dsPIC33EPXXXGM3XX/6XX/7XX

REGISTER 23-7: ADxCSSH: ADCx INPUT SCAN SELECT REGISTER HIGH⁽²⁾

R/W-0	R/W-0	R/W-0	R/W-0	R/W-0	R/W-0	R/W-0	R/W-0
CSS31	CSS30	CSS29	CSS28	CSS27	CSS26 ⁽¹⁾	CSS25 ⁽¹⁾	CSS24 ⁽¹⁾
bit 15							bit 8

R/W-0	R/W-0	R/W-0	R/W-0	R/W-0	R/W-0	R/W-0	R/W-0
CSS23	CSS22	CSS21	CSS20	CSS19	CSS18	CSS17	CSS16
bit 7							bit 0

Legend:

R = Readable bit
-n = Value at POR

W = Writable bit
'1' = Bit is set

U = Unimplemented bit, read as '0'
'0' = Bit is cleared

x = Bit is unknown

- bit 15 **CSS31:** ADCx Input Scan Selection bit
1 = Selects ANx for input scan
0 = Skips ANx for input scan
- bit 14 **CSS30:** ADCx Input Scan Selection bit
1 = Selects ANx for input scan
0 = Skips ANx for input scan
- bit 13 **CSS29:** ADCx Input Scan Selection bits
1 = Selects ANx for input scan
0 = Skips ANx for input scan
- bit 12 **CSS28:** ADCx Input Scan Selection bit
1 = Selects ANx for input scan
0 = Skips ANx for input scan
- bit 11 **CSS27:** ADCx Input Scan Selection bit
1 = Selects ANx for input scan
0 = Skips ANx for input scan
- bit 10 **CSS26:** ADCx Input Scan Selection bit⁽¹⁾
1 = Selects OA3/AN6 for input scan
0 = Skips OA3/AN6 for input scan
- bit 9 **CSS25:** ADCx Input Scan Selection bit⁽¹⁾
1 = Selects OA2/AN0 for input scan
0 = Skips OA2/AN0 for input scan
- bit 8 **CSS24:** ADCx Input Scan Selection bit⁽¹⁾
1 = Selects OA1/AN3 for input scan
0 = Skips OA1/AN3 for input scan
- bit 7 **CSS23:** ADCx Input Scan Selection bit
1 = Selects ANx for input scan
0 = Skips ANx for input scan
- bit 6 **CSS22:** ADCx Input Scan Selection bits
1 = Selects ANx for input scan
0 = Skips ANx for input scan
- bit 5 **CSS21:** ADCx Input Scan Selection bits
1 = Selects ANx for input scan
0 = Skips ANx for input scan

Note 1: If the op amp is selected (OPMODE bit (CMxCON<10>) = 1), the OAx input is used; otherwise, the ANx input is used.

2: All bits in this register can be selected by the user application. However, inputs selected for scan without a corresponding input on the device convert VREFL.

REGISTER 23-7: ADxCSSH: ADCx INPUT SCAN SELECT REGISTER HIGH⁽²⁾ (CONTINUED)

bit 4	CSS20: ADCx Input Scan Selection bit 1 = Selects ANx for input scan 0 = Skips ANx for input scan
bit 3	CSS19: ADCx Input Scan Selection bit 1 = Selects ANx for input scan 0 = Skips ANx for input scan
bit 2	CSS18: ADCx Input Scan Selection bit 1 = Selects ANx for input scan 0 = Skips ANx for input scan
bit 1	CSS17: ADCx Input Scan Selection bit 1 = Selects ANx for input scan 0 = Skips ANx for input scan
bit 0	CSS16: ADCx Input Scan Selection bit 1 = Selects ANx for input scan 0 = Skips ANx for input scan

- Note 1:** If the op amp is selected (OPMODE bit (CMxCON<10>) = 1), the OAx input is used; otherwise, the ANx input is used.
- 2:** All bits in this register can be selected by the user application. However, inputs selected for scan without a corresponding input on the device convert VREFL.

dsPIC33EPXXXGM3XX/6XX/7XX

REGISTER 23-8: ADxCSSL: ADCx INPUT SCAN SELECT REGISTER LOW^(1,2)

R/W-0	R/W-0	R/W-0	R/W-0	R/W-0	R/W-0	R/W-0	R/W-0
CSS<15:8>							
bit 15				bit 8			

R/W-0	R/W-0	R/W-0	R/W-0	R/W-0	R/W-0	R/W-0	R/W-0
CSS<7:0>							
bit 7				bit 0			

Legend:

R = Readable bit W = Writable bit U = Unimplemented bit, read as '0'
-n = Value at POR '1' = Bit is set '0' = Bit is cleared x = Bit is unknown

bit 15-0 **CSS<15:0>**: ADCx Input Scan Selection bits
1 = Selects ANx for input scan
0 = Skips ANx for input scan

- Note 1:** On devices with less than 16 analog inputs, all bits in this register can be selected by the user application. However, inputs selected for scan without a corresponding input on the device convert VREFL.
- 2:** CSSx = ANx, where 'x' = 0-15.

24.0 DATA CONVERTER INTERFACE (DCI) MODULE

Note 1: This data sheet is not intended to be a comprehensive reference source. To complement the information in this data sheet, refer to the “dsPIC33/PIC24 Family Reference Manual”, “Data Converter Interface (DCI) Module” (DS70356), which is available from the Microchip web site (www.microchip.com).

2: Some registers and associated bits described in this section may not be available on all devices. Refer to **Section 4.0 “Memory Organization”** in this data sheet for device-specific register and bit information.

24.1 Module Introduction

The Data Converter Interface (DCI) module allows simple interfacing of devices, such as audio coder/decoders (Codecs), ADC and D/A Converters. The following interfaces are supported:

- Framed Synchronous Serial Transfer (Single or Multi-Channel)
- Inter-IC Sound (I²S) Interface
- AC-Link Compliant mode

General features include:

- Programmable word size up to 16 bits
- Supports up to 16 time slots, for a maximum frame size of 256 bits
- Data buffering for up to 4 samples without CPU overhead

FIGURE 24-1: DCI MODULE BLOCK DIAGRAM

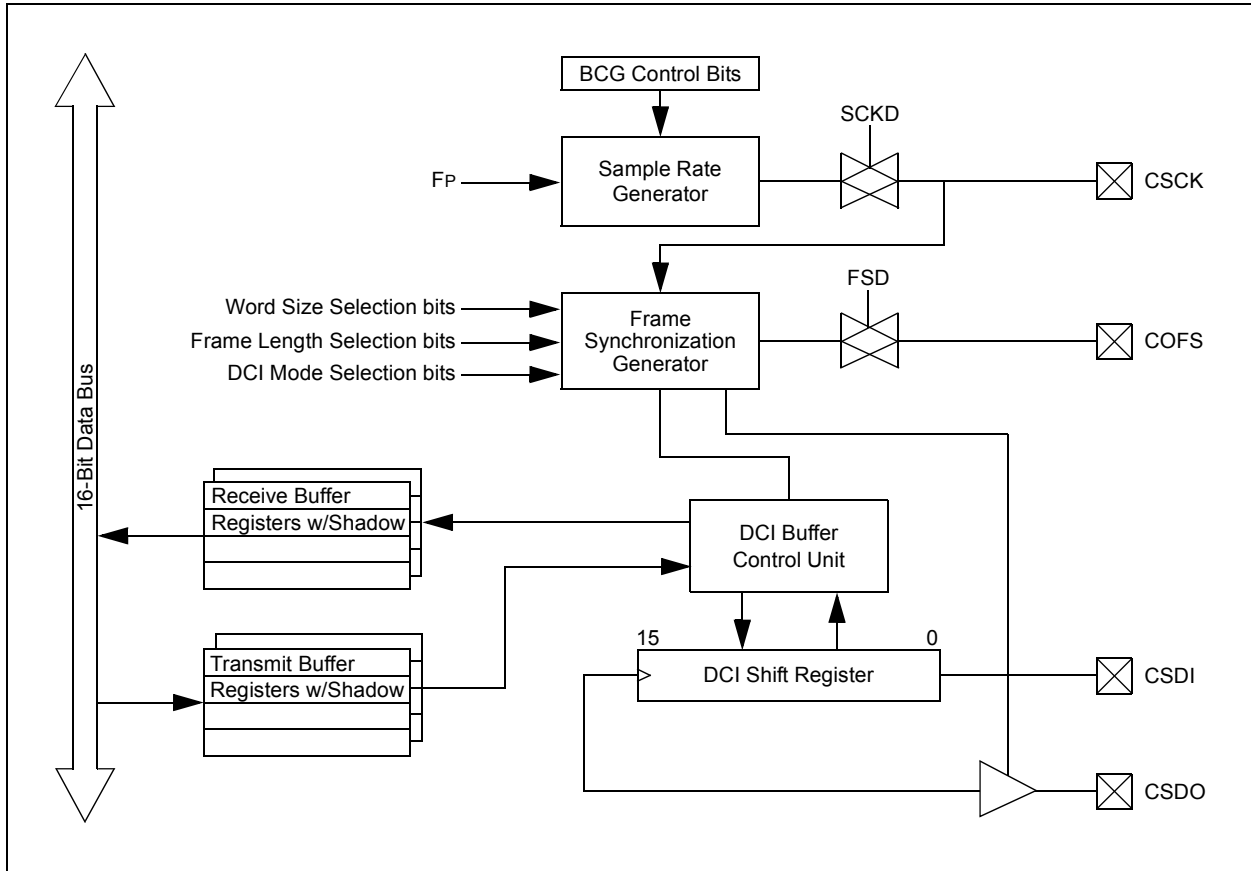

dsPIC33EPXXXGM3XX/6XX/7XX

24.2 DCI Control Registers

REGISTER 24-1: DCICON1: DCI CONTROL REGISTER 1

R/W-0	r-0	R/W-0	r-0	R/W-0	R/W-0	R/W-0	R/W-0
DCIEN	r	DCISIDL	r	DLOOP	CCKD	CCKE	COFSD
bit 15							bit 8

R/W-0	R/W-0	R/W-0	r-0	r-0	r-0	R/W-0	R/W-0
UNFM	CSDOM	DJST	r	r	r	COFSM1	COFSM0
bit 7							bit 0

Legend:	r = Reserved bit		
R = Readable bit	W = Writable bit	U = Unimplemented bit, read as '0'	
-n = Value at POR	'1' = Bit is set	'0' = Bit is cleared	x = Bit is unknown

- bit 15 **DCIEN:** DCI Module Enable bit
1 = DCI module is enabled
0 = DCI module is disabled
- bit 14 **Reserved:** Read as '0'
- bit 13 **DCISIDL:** DCI Stop in Idle Control bit
1 = Module will halt in CPU Idle mode
0 = Module will continue to operate in CPU Idle mode
- bit 12 **Reserved:** Read as '0'
- bit 11 **DLOOP:** Digital Loopback Mode Control bit
1 = Digital Loopback mode is enabled; CSDI and CSDO pins are internally connected
0 = Digital Loopback mode is disabled
- bit 10 **CCKD:** Sample Clock Direction Control bit
1 = CCK pin is an input when DCI module is enabled
0 = CCK pin is an output when DCI module is enabled
- bit 9 **CCKE:** Sample Clock Edge Control bit
1 = Data changes on serial clock falling edge, sampled on serial clock rising edge
0 = Data changes on serial clock rising edge, sampled on serial clock falling edge
- bit 8 **COFSD:** Frame Synchronization Direction Control bit
1 = COFS pin is an input when DCI module is enabled
0 = COFS pin is an output when DCI module is enabled
- bit 7 **UNFM:** Underflow Mode bit
1 = Transmits last value written to the Transmit registers on a transmit underflow
0 = Transmits '0's on a transmit underflow
- bit 6 **CSDOM:** Serial Data Output Mode bit
1 = CSDO pin will be tri-stated during disabled transmit time slots
0 = CSDO pin drives '0's during disabled transmit time slots
- bit 5 **DJST:** DCI Data Justification Control bit
1 = Data transmission/reception is begun during the same serial clock cycle as the frame synchronization pulse
0 = Data transmission/reception is begun one serial clock cycle after the frame synchronization pulse
- bit 4-2 **Reserved:** Read as '0'
- bit 1-0 **COFSM<1:0>:** Frame Sync Mode bits
11 = 20-Bit AC-Link mode
10 = 16-Bit AC-Link mode
01 = I²S Frame Sync mode
00 = Multi-Channel Frame Sync mode

REGISTER 24-2: DCICON2: DCI CONTROL REGISTER 2

r-0	r-0	r-0	r-0	R/W-0	R/W-0	r-0	R/W-0
r	r	r	r	BLEN1	BLEN0	r	COFSG3
bit 15						bit 8	

R/W-0	R/W-0	R/W-0	r-0	R/W-0	R/W-0	R/W-0	R/W-0
COFSG2	COFSG1	COFSG0	r	WS3	WS2	WS1	WS0
bit 7						bit 0	

Legend:	r = Reserved bit	U = Unimplemented bit, read as '0'
R = Readable bit	W = Writable bit	'0' = Bit is cleared
-n = Value at POR	'1' = Bit is set	x = Bit is unknown

bit 15-12 **Reserved:** Read as '0'

bit 11-10 **BLEN<1:0>:** Buffer Length Control bits
 11 = Four data words will be buffered between interrupts
 10 = Three data words will be buffered between interrupts
 01 = Two data words will be buffered between interrupts
 00 = One data word will be buffered between interrupts

bit 9 **Reserved:** Read as '0'

bit 8-5 **COFSG<3:0>:** Frame Sync Generator Control bits
 1111 = Data frame has 16 words
 •
 •
 •
 0010 = Data frame has 3 words
 0001 = Data frame has 2 words
 0000 = Data frame has 1 word

bit 4 **Reserved:** Read as '0'

bit 3-0 **WS<3:0>:** DCI Data Word Size bits
 1111 = Data word size is 16 bits
 •
 •
 •
 0100 = Data word size is 5 bits
 0011 = Data word size is 4 bits
 0010 = **Invalid Selection.** Do not use. Unexpected results may occur.
 0001 = **Invalid Selection.** Do not use. Unexpected results may occur.
 0000 = **Invalid Selection.** Do not use. Unexpected results may occur.

dsPIC33EPXXXGM3XX/6XX/7XX

REGISTER 24-3: DCICON3: DCI CONTROL REGISTER 3

r-0	r-0	r-0	r-0	R/W-0	R/W-0	R/W-0	R/W-0
r	r	r	r	BCG<11:8>			
bit 15							bit 8

R/W-0	R/W-0	R/W-0	R/W-0	R/W-0	R/W-0	R/W-0	R/W-0
BCG<7:0>							
bit 7							bit 0

Legend:	r = Reserved bit		
R = Readable bit	W = Writable bit	U = Unimplemented bit, read as '0'	
-n = Value at POR	'1' = Bit is set	'0' = Bit is cleared	x = Bit is unknown

bit 15-12 **Reserved:** Read as '0'
bit 11-0 **BCG<11:0>:** DCI Bit Clock Generator Control bits

REGISTER 24-4: DCISTAT: DCI STATUS REGISTER

r-0	r-0	r-0	r-0	R-0	R-0	R-0	R-0
r	r	r	r	SLOT3	SLOT2	SLOT1	SLOT0
bit 15							bit 8

r-0	r-0	r-0	r-0	R-0	R-0	R-0	R-0
r	r	r	r	ROV	RFUL	TUNF	TMPTY
bit 7							bit 0

Legend:	r = Reserved bit	U = Unimplemented bit, read as '0'
R = Readable bit	W = Writable bit	'0' = Bit is cleared
-n = Value at POR	'1' = Bit is set	x = Bit is unknown

- bit 15-12 **Reserved:** Read as '0'
- bit 11-8 **SLOT<3:0>:** DCI Slot Status bits
 - 1111 = Slot 15 is currently active
 -
 -
 -
 - 0010 = Slot 2 is currently active
 - 0001 = Slot 1 is currently active
 - 0000 = Slot 0 is currently active
- bit 7-4 **Reserved:** Read as '0'
- bit 3 **ROV:** Receive Overflow Status bit
 - 1 = A receive overflow has occurred for at least one Receive register
 - 0 = A receive overflow has not occurred
- bit 2 **RFUL:** Receive Buffer Full Status bit
 - 1 = New data is available in the Receive registers
 - 0 = The Receive registers have old data
- bit 1 **TUNF:** Transmit Buffer Underflow Status bit
 - 1 = A transmit underflow has occurred for at least one Transmit register
 - 0 = A transmit underflow has not occurred
- bit 0 **TMPTY:** Transmit Buffer Empty Status bit
 - 1 = The Transmit registers are empty
 - 0 = The Transmit registers are not empty

dsPIC33EPXXXGM3XX/6XX/7XX

REGISTER 24-5: RSCON: DCI RECEIVE SLOT CONTROL REGISTER

R/W-0	R/W-0	R/W-0	R/W-0	R/W-0	R/W-0	R/W-0	R/W-0
RSE<15:8>							
bit 15							bit 8

R/W-0	R/W-0	R/W-0	R/W-0	R/W-0	R/W-0	R/W-0	R/W-0
RSE<7:0>							
bit 7							bit 0

Legend:

R = Readable bit W = Writable bit U = Unimplemented bit, read as '0'
-n = Value at POR '1' = Bit is set '0' = Bit is cleared x = Bit is unknown

bit 15-0 **RSE<15:0>**: DCI Receive Slot Enable bits
1 = CSDI data is received during Individual Time Slot n
0 = CSDI data is ignored during Individual Time Slot n

REGISTER 24-6: TSCON: DCI TRANSMIT SLOT CONTROL REGISTER

R/W-0	R/W-0	R/W-0	R/W-0	R/W-0	R/W-0	R/W-0	R/W-0
TSE<15:8>							
bit 15							bit 8

R/W-0	R/W-0	R/W-0	R/W-0	R/W-0	R/W-0	R/W-0	R/W-0
TSE<7:0>							
bit 7							bit 0

Legend:

R = Readable bit W = Writable bit U = Unimplemented bit, read as '0'
-n = Value at POR '1' = Bit is set '0' = Bit is cleared x = Bit is unknown

bit 15-0 **TSE<15:0>**: DCI Transmit Slot Enable Control bits
1 = Transmit buffer contents are sent during Individual Time Slot n
0 = CSDO pin is tri-stated or driven to logic '0' during the individual time slot, depending on the state of the CSDOM bit

25.0 PERIPHERAL TRIGGER GENERATOR (PTG) MODULE

Note 1: This data sheet summarizes the features of the dsPIC33EPXXXGM3XX/6XX/7XX family of devices. It is not intended to be a comprehensive reference source. To complement the information in this data sheet, refer to the “dsPIC33/PIC24 Family Reference Manual”, “Peripheral Trigger Generator (PTG)” (DS70669), which is available from the Microchip web site (www.microchip.com).

2: Some registers and associated bits described in this section may not be available on all devices. Refer to [Section 4.0 “Memory Organization”](#) in this data sheet for device-specific register and bit information.

25.1 Module Introduction

The Peripheral Trigger Generator (PTG) provides a means to schedule complex, high-speed peripheral operations that would be difficult to achieve using software. The PTG module uses 8-bit commands, called “steps”, that the user writes to the PTG Queue register (PTGQUE0-PTQUE15), which performs operations, such as wait for input signal, generate output trigger and wait for timer.

The PTG module has the following major features:

- Multiple Clock Sources
- Two 16-Bit General Purpose Timers
- Two 16-Bit General Limit Counters
- Configurable for Rising or Falling Edge Triggering
- Generates Processor Interrupts to Include:
 - Four configurable processor interrupts
 - Interrupt on a step event in Single-Step mode
 - Interrupt on a PTG Watchdog Timer time-out
- Able to Receive Trigger Signals from these Peripherals:
 - ADC
 - PWM
 - Output Compare
 - Input Capture
 - Op Amp/Comparator
 - INT2
- Able to Trigger or Synchronize to these Peripherals:
 - Watchdog Timer
 - Output Compare
 - Input Capture
 - ADC
 - PWM
 - Op Amp/Comparator

dsPIC33EPXXXGM3XX/6XX/7XX

FIGURE 25-1: PTG BLOCK DIAGRAM

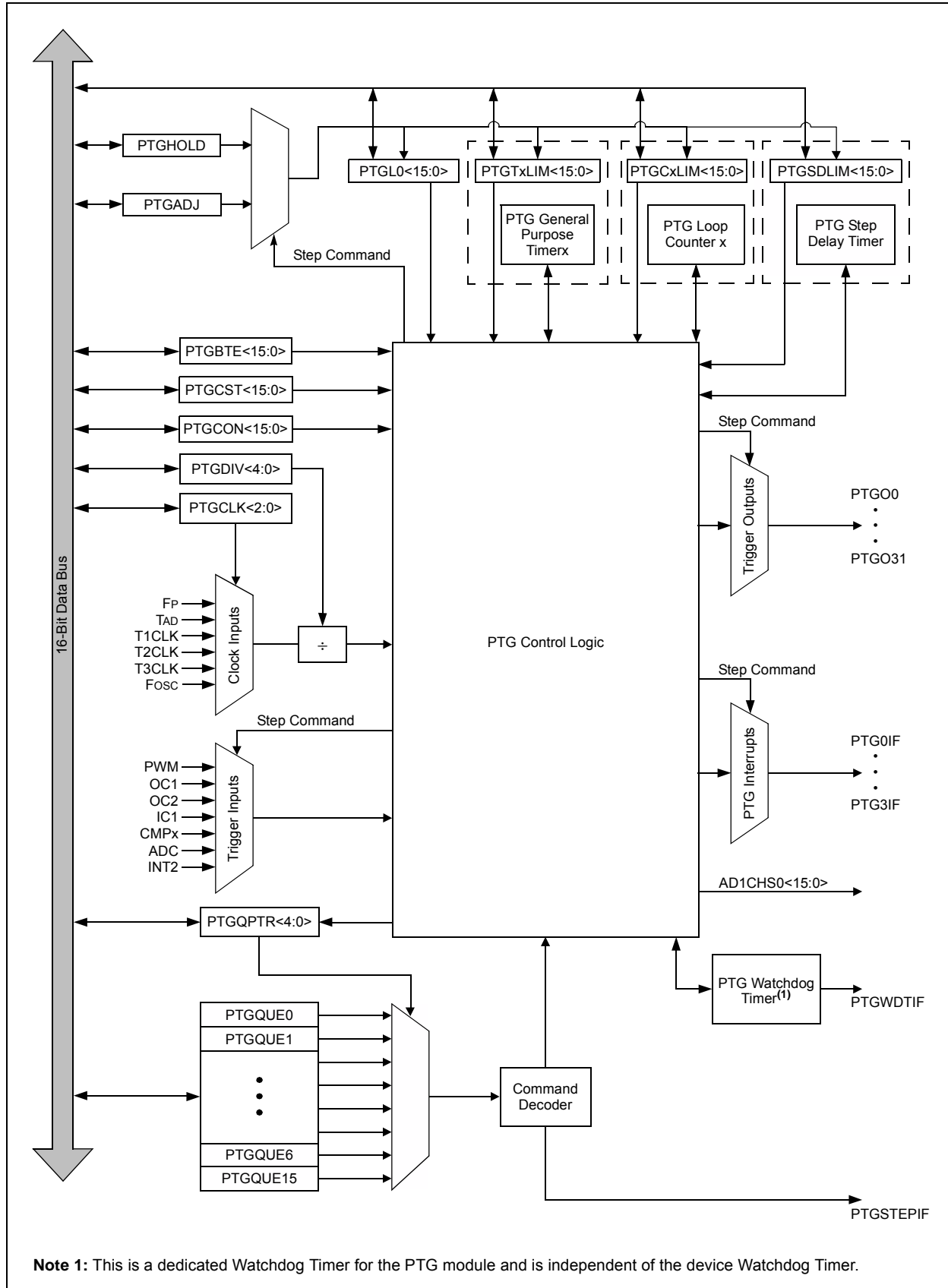

25.2 PTG Control Registers

REGISTER 25-1: PTGCST: PTG CONTROL/STATUS REGISTER

R/W-0	U-0	R/W-0	R/W-0	U-0	R/W-0	R/W-0	R/W-0
PTGEN	—	PTGSIDL	PTGTOGL	—	PTGSWT ⁽²⁾	PTGSSEN	PTGIVIS
bit 15							bit 8

R/W-0	HS-0	U-0	U-0	U-0	U-0	R/W-0	R/W-0
PTGSTRT	PTGWDTO	—	—	—	—	PTGITM1 ⁽¹⁾	PTGITM0 ⁽¹⁾
bit 7							bit 0

Legend:	HS = Hardware Settable bit
R = Readable bit	W = Writable bit
-n = Value at POR	'1' = Bit is set
	U = Unimplemented bit, read as '0'
	'0' = Bit is cleared
	x = Bit is unknown

- bit 15 **PTGEN:** PTG Module Enable bit
 1 = PTG module is enabled
 0 = PTG module is disabled
- bit 14 **Unimplemented:** Read as '0'
- bit 13 **PTGSIDL:** PTG Stop in Idle Mode bit
 1 = Discontinues module operation when device enters Idle mode
 0 = Continues module operation in Idle mode
- bit 12 **PTGTOGL:** PTG TRIG Output Toggle Mode bit
 1 = Toggles the state of the PTGOx for each execution of the PTGTRIG command
 0 = Each execution of the PTGTRIG command will generate a single PTGOx pulse determined by the value in the PTGPWDx bits
- bit 11 **Unimplemented:** Read as '0'
- bit 10 **PTGSWT:** PTG Software Trigger bit⁽²⁾
 1 = Triggers the PTG module
 0 = No action (clearing this bit will have no effect)
- bit 9 **PTGSSEN:** PTG Enable Single-Step bit
 1 = Enables Single-Step mode
 0 = Disables Single-Step mode
- bit 8 **PTGIVIS:** PTG Counter/Timer Visibility Control bit
 1 = Reads of the PTGSDLIM, PTGCxLIM or PTGTxLIM registers return the current values of their corresponding Counter/Timer registers (PTGSD, PTGCx, PTGTx)
 0 = Reads of the PTGSDLIM, PTGCxLIM or PTGTxLIM registers return the value previously written to those PTG Limit registers
- bit 7 **PTGSTRT:** Start PTG Sequencer bit
 1 = Starts to sequentially execute commands (Continuous mode)
 0 = Stops executing commands
- bit 6 **PTGWDTO:** PTG Watchdog Timer Time-out Status bit
 1 = PTG Watchdog Timer has timed out
 0 = PTG Watchdog Timer has not timed out.
- bit 5-2 **Unimplemented:** Read as '0'

Note 1: These bits apply to the PTGWHI and PTGWLO commands only.
Note 2: This bit is only used with the PTGCTRL Step command software trigger option.

dsPIC33EPXXXGM3XX/6XX/7XX

REGISTER 25-1: PTGCST: PTG CONTROL/STATUS REGISTER (CONTINUED)

- bit 1-0 **PTGITM<1:0>**: PTG Input Trigger Command Operating Mode bits⁽¹⁾
- 11 = Single level detect with step delay is not executed on exit of command (regardless of PTGCTRL command)
 - 10 = Single level detect with step delay is executed on exit of command
 - 01 = Continuous edge detect with step delay is not executed on exit of command (regardless of PTGCTRL command)
 - 00 = Continuous edge detect with step delay is executed on exit of command

- Note 1:** These bits apply to the PTGWHI and PTGWLO commands only.
- 2:** This bit is only used with the PTGCTRL Step command software trigger option.

REGISTER 25-2: PTGCON: PTG CONTROL REGISTER

R/W-0	R/W-0	R/W-0	R/W-0	R/W-0	R/W-0	R/W-0	R/W-0
PTGCLK2	PTGCLK1	PTGCLK0	PTGDIV4	PTGDIV3	PTGDIV2	PTGDIV1	PTGDIV0
bit 15							bit 8

R/W-0	R/W-0	R/W-0	R/W-0	U-0	R/W-0	R/W-0	R/W-0
PTGPWD3	PTGPWD2	PTGPWD1	PTGPWD0	—	PTGWDT2	PTGWDT1	PTGWDT0
bit 7							bit 0

Legend:			
R = Readable bit	W = Writable bit	U = Unimplemented bit, read as '0'	
-n = Value at POR	'1' = Bit is set	'0' = Bit is cleared	x = Bit is unknown

- bit 15-13 **PTGCLK<2:0>**: Select PTG Module Clock Source bits
 - 111 = Reserved
 - 110 = Reserved
 - 101 = PTG module clock source will be T3CLK
 - 100 = PTG module clock source will be T2CLK
 - 011 = PTG module clock source will be T1CLK
 - 010 = PTG module clock source will be TAD
 - 001 = PTG module clock source will be FOSC
 - 000 = PTG module clock source will be FP

- bit 12-8 **PTGDIV<4:0>**: PTG Module Clock Prescaler (divider) bits
 - 11111 = Divide-by-32
 - 11110 = Divide-by-31
 -
 -
 -
 - 00001 = Divide-by-2
 - 00000 = Divide-by-1

- bit 7-4 **PTGPWD<3:0>**: PTG Trigger Output Pulse-Width bits
 - 1111 = All trigger outputs are 16 PTG clock cycles wide
 - 1110 = All trigger outputs are 15 PTG clock cycles wide
 -
 -
 -
 - 0001 = All trigger outputs are 2 PTG clock cycles wide
 - 0000 = All trigger outputs are 1 PTG clock cycle wide

- bit 3 **Unimplemented**: Read as '0'

- bit 2-0 **PTGWDT<2:0>**: Select PTG Watchdog Timer Time-out Count Value bits
 - 111 = Watchdog Timer will time-out after 512 PTG clocks
 - 110 = Watchdog Timer will time-out after 256 PTG clocks
 - 101 = Watchdog Timer will time-out after 128 PTG clocks
 - 100 = Watchdog Timer will time-out after 64 PTG clocks
 - 011 = Watchdog Timer will time-out after 32 PTG clocks
 - 010 = Watchdog Timer will time-out after 16 PTG clocks
 - 001 = Watchdog Timer will time-out after 8 PTG clocks
 - 000 = Watchdog Timer is disabled

dsPIC33EPXXXGM3XX/6XX/7XX

REGISTER 25-3: PTGBTE: PTG BROADCAST TRIGGER ENABLE REGISTER^(1,2)

R/W-0	R/W-0	R/W-0	R/W-0	R/W-0	R/W-0	R/W-0	R/W-0
ADCTS4	ADCTS3	ADCTS2	ADCTS1	IC4TSS	IC3TSS	IC2TSS	IC1TSS
bit 15							bit 8

R/W-0	R/W-0	R/W-0	R/W-0	R/W-0	R/W-0	R/W-0	R/W-0
OC4CS	OC3CS	OC2CS	OC1CS	OC4TSS	OC3TSS	OC2TSS	OC1TSS
bit 7							bit 0

Legend:

R = Readable bit	W = Writable bit	U = Unimplemented bit, read as '0'
-n = Value at POR	'1' = Bit is set	'0' = Bit is cleared
		x = Bit is unknown

- bit 15 **ADCTS4:** Sample Trigger PTGO15 for ADCx bit
 1 = Generates trigger when the broadcast command is executed
 0 = Does not generate trigger when the broadcast command is executed
- bit 14 **ADCTS3:** Sample Trigger PTGO14 for ADCx bit
 1 = Generates trigger when the broadcast command is executed
 0 = Does not generate trigger when the broadcast command is executed
- bit 13 **ADCTS2:** Sample Trigger PTGO13 for ADCx bit
 1 = Generates trigger when the broadcast command is executed
 0 = Does not generate trigger when the broadcast command is executed
- bit 12 **ADCTS1:** Sample Trigger PTGO12 for ADCx bit
 1 = Generates trigger when the broadcast command is executed
 0 = Does not generate trigger when the broadcast command is executed
- bit 11 **IC4TSS:** Trigger/Synchronization Source for IC4 bit
 1 = Generates trigger/synchronization when the broadcast command is executed
 0 = Does not generate trigger/synchronization when the broadcast command is executed
- bit 10 **IC3TSS:** Trigger/Synchronization Source for IC3 bit
 1 = Generates trigger/synchronization when the broadcast command is executed
 0 = Does not generate trigger/synchronization when the broadcast command is executed
- bit 9 **IC2TSS:** Trigger/Synchronization Source for IC2 bit
 1 = Generates trigger/synchronization when the broadcast command is executed
 0 = Does not generate trigger/synchronization when the broadcast command is executed
- bit 8 **IC1TSS:** Trigger/Synchronization Source for IC1 bit
 1 = Generates trigger/synchronization when the broadcast command is executed
 0 = Does not generate trigger/synchronization when the broadcast command is executed
- bit 7 **OC4CS:** Clock Source for OC4 bit
 1 = Generates clock pulse when the broadcast command is executed
 0 = Does not generate clock pulse when the broadcast command is executed
- bit 6 **OC3CS:** Clock Source for OC3 bit
 1 = Generates clock pulse when the broadcast command is executed
 0 = Does not generate clock pulse when the broadcast command is executed
- bit 5 **OC2CS:** Clock Source for OC2 bit
 1 = Generates clock pulse when the broadcast command is executed
 0 = Does not generate clock pulse when the broadcast command is executed

Note 1: This register is read-only when the PTG module is executing Step commands (PTGEN = 1 and PTGSTR = 1).

2: This register is only used with the PTGCTRL OPTION = 1111 Step command.

REGISTER 25-3: PTGBTE: PTG BROADCAST TRIGGER ENABLE REGISTER^(1,2) (CONTINUED)

bit 4	OC1CS: Clock Source for OC1 bit 1 = Generates clock pulse when the broadcast command is executed 0 = Does not generate clock pulse when the broadcast command is executed
bit 3	OC4TSS: Trigger/Synchronization Source for OC4 bit 1 = Generates trigger/synchronization when the broadcast command is executed 0 = Does not generate trigger/synchronization when the broadcast command is executed
bit 2	OC3TSS: Trigger/Synchronization Source for OC3 bit 1 = Generates trigger/synchronization when the broadcast command is executed 0 = Does not generate trigger/synchronization when the broadcast command is executed
bit 1	OC2TSS: Trigger/Synchronization Source for OC2 bit 1 = Generates trigger/synchronization when the broadcast command is executed 0 = Does not generate trigger/synchronization when the broadcast command is executed
bit 0	OC1TSS: Trigger/Synchronization Source for OC1 bit 1 = Generates trigger/synchronization when the broadcast command is executed 0 = Does not generate trigger/synchronization when the broadcast command is executed

Note 1: This register is read-only when the PTG module is executing Step commands (PTGEN = 1 and PTGSTRT = 1).

2: This register is only used with the PTGCTRL OPTION = 1111 Step command.

dsPIC33EPXXXGM3XX/6XX/7XX

REGISTER 25-4: PTGT0LIM: PTG TIMER0 LIMIT REGISTER⁽¹⁾

R/W-0	R/W-0	R/W-0	R/W-0	R/W-0	R/W-0	R/W-0	R/W-0
PTGT0LIM<15:8>							
bit 15							bit 8

R/W-0	R/W-0	R/W-0	R/W-0	R/W-0	R/W-0	R/W-0	R/W-0
PTGT0LIM<7:0>							
bit 7							bit 0

Legend:

R = Readable bit W = Writable bit U = Unimplemented bit, read as '0'
-n = Value at POR '1' = Bit is set '0' = Bit is cleared x = Bit is unknown

bit 15-0 **PTGT0LIM<15:0>**: PTG Timer0 Limit Register bits
General purpose Timer0 Limit register (effective only with a PTGT0 Step command).

Note 1: This register is read-only when the PTG module is executing Step commands (PTGEN = 1 and PTGSTRT = 1).

REGISTER 25-5: PTGT1LIM: PTG TIMER1 LIMIT REGISTER⁽¹⁾

R/W-0	R/W-0	R/W-0	R/W-0	R/W-0	R/W-0	R/W-0	R/W-0
PTGT1LIM<15:8>							
bit 15							bit 8

R/W-0	R/W-0	R/W-0	R/W-0	R/W-0	R/W-0	R/W-0	R/W-0
PTGT1LIM<7:0>							
bit 7							bit 0

Legend:

R = Readable bit W = Writable bit U = Unimplemented bit, read as '0'
-n = Value at POR '1' = Bit is set '0' = Bit is cleared x = Bit is unknown

bit 15-0 **PTGT1LIM<15:0>**: PTG Timer1 Limit Register bits
General purpose Timer1 Limit register (effective only with a PTGT1 Step command).

Note 1: This register is read-only when the PTG module is executing Step commands (PTGEN = 1 and PTGSTRT = 1).

REGISTER 25-6: PTGSDLIM: PTG STEP DELAY LIMIT REGISTER^(1,2)

R/W-0	R/W-0	R/W-0	R/W-0	R/W-0	R/W-0	R/W-0	R/W-0
PTGSDLIM<15:8>							
bit 15				bit 8			

R/W-0	R/W-0	R/W-0	R/W-0	R/W-0	R/W-0	R/W-0	R/W-0
PTGSDLIM<7:0>							
bit 7				bit 0			

Legend:			
R = Readable bit	W = Writable bit	U = Unimplemented bit, read as '0'	
-n = Value at POR	'1' = Bit is set	'0' = Bit is cleared	x = Bit is unknown

bit 15-0 **PTGSDLIM<15:0>**: PTG Step Delay Limit Register bits
 Holds a PTG step delay value, representing the number of additional PTG clocks, between the start of a Step command and the completion of a Step command.

- Note 1:** A base step delay of one PTG clock is added to any value written to the PTGSDLIM register (Step Delay = (PTGSDLIM) + 1).
- 2:** This register is read-only when the PTG module is executing Step commands (PTGEN = 1 and PTGSTRT = 1).

REGISTER 25-7: PTGC0LIM: PTG COUNTER 0 LIMIT REGISTER⁽¹⁾

R/W-0	R/W-0	R/W-0	R/W-0	R/W-0	R/W-0	R/W-0	R/W-0
PTGC0LIM<15:8>							
bit 15				bit 8			

R/W-0	R/W-0	R/W-0	R/W-0	R/W-0	R/W-0	R/W-0	R/W-0
PTGC0LIM<7:0>							
bit 7				bit 0			

Legend:			
R = Readable bit	W = Writable bit	U = Unimplemented bit, read as '0'	
-n = Value at POR	'1' = Bit is set	'0' = Bit is cleared	x = Bit is unknown

bit 15-0 **PTGC0LIM<15:0>**: PTG Counter 0 Limit Register bits
 May be used to specify the loop count for the PTGJMPC0 Step command or as a limit register for the General Purpose Counter 0.

- Note 1:** This register is read-only when the PTG module is executing Step commands (PTGEN = 1 and PTGSTRT = 1).

dsPIC33EPXXXGM3XX/6XX/7XX

REGISTER 25-8: PTGC1LIM: PTG COUNTER 1 LIMIT REGISTER⁽¹⁾

R/W-0	R/W-0	R/W-0	R/W-0	R/W-0	R/W-0	R/W-0	R/W-0
PTGC1LIM<15:8>							
bit 15				bit 8			

R/W-0	R/W-0	R/W-0	R/W-0	R/W-0	R/W-0	R/W-0	R/W-0
PTGC1LIM<7:0>							
bit 7				bit 0			

Legend:

R = Readable bit W = Writable bit U = Unimplemented bit, read as '0'
-n = Value at POR '1' = Bit is set '0' = Bit is cleared x = Bit is unknown

bit 15-0 **PTGC1LIM<15:0>**: PTG Counter 1 Limit Register bits
May be used to specify the loop count for the `PTGJMPC1` Step command, or as a limit register for the General Purpose Counter 1.

Note 1: This register is read-only when the PTG module is executing Step commands (PTGEN = 1 and PTGSTRT = 1).

REGISTER 25-9: PTGHOLD: PTG HOLD REGISTER⁽¹⁾

R/W-0	R/W-0	R/W-0	R/W-0	R/W-0	R/W-0	R/W-0	R/W-0
PTGHOLD<15:8>							
bit 15				bit 8			

R/W-0	R/W-0	R/W-0	R/W-0	R/W-0	R/W-0	R/W-0	R/W-0
PTGHOLD<7:0>							
bit 7				bit 0			

Legend:

R = Readable bit W = Writable bit U = Unimplemented bit, read as '0'
-n = Value at POR '1' = Bit is set '0' = Bit is cleared x = Bit is unknown

bit 15-0 **PTGHOLD<15:0>**: PTG General Purpose Hold Register bits
Holds user-supplied data to be copied to the `PTGTxLIM`, `PTGCxLIM`, `PTGSDLIM` or `PTGL0` register with the `PTGCOPY` command.

Note 1: This register is read-only when the PTG module is executing Step commands (PTGEN = 1 and PTGSTRT = 1).

REGISTER 25-10: PTGADJ: PTG ADJUST REGISTER⁽¹⁾

R/W-0	R/W-0	R/W-0	R/W-0	R/W-0	R/W-0	R/W-0	R/W-0	
PTGADJ<15:8>								
bit 15								bit 8

R/W-0	R/W-0	R/W-0	R/W-0	R/W-0	R/W-0	R/W-0	R/W-0	
PTGADJ<7:0>								
bit 7								bit 0

Legend:

R = Readable bit	W = Writable bit	U = Unimplemented bit, read as '0'
-n = Value at POR	'1' = Bit is set	'0' = Bit is cleared x = Bit is unknown

bit 15-0 **PTGADJ<15:0>**: PTG Adjust Register bits
 This register holds user-supplied data to be added to the PTGTxLIM, PTGCxLIM, PTGSDLIM or PTGL0 register with the PTGADD command.

Note 1: This register is read-only when the PTG module is executing Step commands (PTGEN = 1 and PTGSTRT = 1).

REGISTER 25-11: PTGL0: PTG LITERAL 0 REGISTER⁽¹⁾

R/W-0	R/W-0	R/W-0	R/W-0	R/W-0	R/W-0	R/W-0	R/W-0	
PTGL0<15:8>								
bit 15								bit 8

R/W-0	R/W-0	R/W-0	R/W-0	R/W-0	R/W-0	R/W-0	R/W-0	
PTGL0<7:0>								
bit 7								bit 0

Legend:

R = Readable bit	W = Writable bit	U = Unimplemented bit, read as '0'
-n = Value at POR	'1' = Bit is set	'0' = Bit is cleared x = Bit is unknown

bit 15-0 **PTGL0<15:0>**: PTG Literal 0 Register bits
 This register holds the 16-bit value to be written to the AD1CHS0 register with the PTGCTRL Step command.

Note 1: This register is read-only when the PTG module is executing Step commands (PTGEN = 1 and PTGSTRT = 1).

dsPIC33EPXXXGM3XX/6XX/7XX

REGISTER 25-12: PTGQPTR: PTG STEP QUEUE POINTER REGISTER⁽¹⁾

U-0	U-0	U-0	U-0	U-0	U-0	U-0	U-0
—	—	—	—	—	—	—	—
bit 15							bit 8

U-0	U-0	U-0	R/W-0	R/W-0	R/W-0	R/W-0	R/W-0
—	—	—	PTGQPTR<4:0>				
bit 7							bit 0

Legend:

R = Readable bit W = Writable bit U = Unimplemented bit, read as '0'
 -n = Value at POR '1' = Bit is set '0' = Bit is cleared x = Bit is unknown

bit 15-5 **Unimplemented:** Read as '0'

bit 4-0 **PTGQPTR<4:0>:** PTG Step Queue Pointer Register bits
 This register points to the currently active Step command in the step queue.

Note 1: This register is read-only when the PTG module is executing Step commands (PTGEN = 1 and PTGSTRT = 1).

REGISTER 25-13: PTGQUE_x: PTG STEP QUEUE REGISTER x (x = 0-15)^(1,3)

R/W-0	R/W-0	R/W-0	R/W-0	R/W-0	R/W-0	R/W-0	R/W-0
STEP(2x + 1)<7:0> ⁽²⁾							
bit 15							bit 8

R/W-0	R/W-0	R/W-0	R/W-0	R/W-0	R/W-0	R/W-0	R/W-0
STEP(2x)<7:0> ⁽²⁾							
bit 7							bit 0

Legend:

R = Readable bit W = Writable bit U = Unimplemented bit, read as '0'
 -n = Value at POR '1' = Bit is set '0' = Bit is cleared x = Bit is unknown

bit 15-8 **STEP(2x + 1)<7:0>:** PTG Step Queue Pointer Register bits⁽²⁾
 A queue location for storage of the STEP(2x + 1) command byte.

bit 7-0 **STEP(2x)<7:0>:** PTG Step Queue Pointer Register bits⁽²⁾
 A queue location for storage of the STEP(2x) command byte.

Note 1: This register is read-only when the PTG module is executing Step commands (PTGEN = 1 and PTGSTRT = 1).

2: Refer to [Table 25-1](#) for the Step command encoding.

3: The Step registers maintain their values on any type of Reset.

25.3 Step Commands and Format

TABLE 25-1: PTG STEP COMMAND FORMAT

Step Command Byte:			
STEPx<7:0>			
CMD<3:0>		OPTION<3:0>	
bit 7	bit 4	bit 3	bit 0

bit 7-4	CMD<3:0>	Step Command	Command Description
	0000	PTGCTRL	Execute control command as described by OPTION<3:0>
	0001	PTGADD	Add contents of PTGADJ register to target register as described by OPTION<3:0>
		PTGCOPY	Copy contents of PTGHOLD register to target register as described by OPTION<3:0>
	001x	PTGSTRB	Copy the value contained in CMD0:OPTION<3:0> to the CH0SA<4:0> bits (AD1CHS0<4:0>)
	0100	PTGWHI	Wait for a low-to-high edge input from selected PTG trigger input as described by OPTION<3:0>
	0101	PTGWLO	Wait for a high-to-low edge input from selected PTG trigger input as described by OPTION<3:0>
	0110	Reserved	Reserved
	0111	PTGIRQ	Generate individual interrupt request as described by OPTION<3:0>
	100x	PTGTRIG	Generate individual trigger output as described by <<CMD0>:OPTION<3:0>>
	101x	PTGJMP	Copy the value indicated in <<CMD0>:OPTION<3:0>> to the Queue Pointer (PTGQPTR) and jump to that step queue
	110x	PTGJMPC0	PTGC0 = PTGC0LIM: Increment the Queue Pointer (PTGQPTR)
			PTGC0 ≠ PTGC0LIM: Increment Counter 0 (PTGC0) and copy the value indicated in <<CMD0>:OPTION<3:0>> to the Queue Pointer (PTGQPTR) and jump to that step queue
	111x	PTGJMPC1	PTGC1 = PTGC1LIM: Increment the Queue Pointer (PTGQPTR)
			PTGC1 ≠ PTGC1LIM: Increment Counter 1 (PTGC1) and copy the value indicated in <<CMD0>:OPTION<3:0>> to the Queue Pointer (PTGQPTR) and jump to that step queue

- Note 1:** All reserved commands or options will execute but have no effect (i.e., execute as a NOP instruction).
Note 2: Refer to [Table 25-2](#) for the trigger output descriptions.

TABLE 25-1: PTG STEP COMMAND FORMAT (CONTINUED)

bit 3-0	Step Command	OPTION<3:0>	Option Description
	PTGCTRL ⁽¹⁾	0000	Reserved
		0001	Reserved
		0010	Disable Step Delay Timer (PTGSD)
		0011	Reserved
		0100	Reserved
		0101	Reserved
		0110	Enable Step Delay Timer (PTGSD)
		0111	Reserved
		1000	Start and wait for the PTG Timer0 to match Timer0 Limit register
		1001	Start and wait for the PTG Timer1 to match Timer1 Limit register
		1010	Reserved
		1011	Wait for software trigger bit transition from low-to-high before continuing (PTGSWT = 0 to 1)
		1100	Copy contents of the Counter 0 register to the AD1CHS0 register
		1101	Copy contents of the Counter 1 register to the AD1CHS0 register
		1110	Copy contents of the Literal 0 register to the AD1CHS0 register
	1111	Generate the triggers indicated in the PTG Broadcast Trigger Enable register (PTGBTE)	
	PTGADD ⁽¹⁾	0000	Add contents of PTGADJ register to the Counter 0 Limit register (PTGC0LIM)
		0001	Add contents of PTGADJ register to the Counter 1 Limit register (PTGC1LIM)
		0010	Add contents of PTGADJ register to the Timer0 Limit register (PTGT0LIM)
		0011	Add contents of PTGADJ register to the Timer1 Limit register (PTGT1LIM)
		0100	Add contents of PTGADJ register to the Step Delay Limit register (PTGSDLIM)
		0101	Add contents of PTGADJ register to the Literal 0 register (PTGL0)
		0110	Reserved
		0111	Reserved
	PTGCOPY ⁽¹⁾	1000	Copy contents of PTGHOLD register to the Counter 0 Limit register (PTGC0LIM)
		1001	Copy contents of PTGHOLD register to the Counter 1 Limit register (PTGC1LIM)
		1010	Copy contents of PTGHOLD register to the Timer0 Limit register (PTGT0LIM)
		1011	Copy contents of PTGHOLD register to the Timer1 Limit register (PTGT1LIM)
		1100	Copy contents of PTGHOLD register to the Step Delay Limit register (PTGSDLIM)
		1101	Copy contents of PTGHOLD register to the Literal 0 register (PTGL0)
		1110	Reserved
		1111	Reserved

Note 1: All reserved commands or options will execute but have no effect (i.e., execute as a NOP instruction).

2: Refer to [Table 25-2](#) for the trigger output descriptions.

TABLE 25-1: PTG STEP COMMAND FORMAT (CONTINUED)

bit 3-0	Step Command	OPTION<3:0>	Option Description
	PTGWHI ⁽¹⁾ or PTGWLO ⁽¹⁾	0000	PWM Special Event Trigger
		0001	PWM master time base synchronization output
		0010	PWM1 interrupt
		0011	PWM2 interrupt
		0100	PWM3 interrupt
		0101	PWM4 interrupt
		0110	PWM5 interrupt
		0111	OC1 Trigger Event
		1000	OC2 Trigger Event
		1001	IC1 Trigger Event
		1010	CMP1 Trigger Event
		1011	CMP2 Trigger Event
		1100	CMP3 Trigger Event
		1101	CMP4 Trigger Event
		1110	ADC conversion done interrupt
		1111	INT2 external interrupt
	PTGIRQ ⁽¹⁾	0000	Generate PTG Interrupt 0
		0001	Generate PTG Interrupt 1
		0010	Generate PTG Interrupt 2
		0011	Generate PTG Interrupt 3
		0100	Reserved
		• • •	• • •
		1111	Reserved
		PTGTRIG ⁽²⁾	00000
	00001		PTGO1
	• • •		• • •
	11110		PTGO30
	11111		PTGO31

- Note 1:** All reserved commands or options will execute but have no effect (i.e., execute as a NOP instruction).
Note 2: Refer to [Table 25-2](#) for the trigger output descriptions.

dsPIC33EPXXXGM3XX/6XX/7XX

TABLE 25-2: PTG OUTPUT DESCRIPTIONS

PTG Output Number	PTG Output Description
PTGO0	Trigger/Synchronization Source for OC1
PTGO1	Trigger/Synchronization Source for OC2
PTGO2	Trigger/Synchronization Source for OC3
PTGO3	Trigger/Synchronization Source for OC4
PTGO4	Clock Source for OC1
PTGO5	Clock Source for OC2
PTGO6	Clock Source for OC3
PTGO7	Clock Source for OC4
PTGO8	Trigger/Synchronization Source for IC1
PTGO9	Trigger/Synchronization Source for IC2
PTGO10	Trigger/Synchronization Source for IC3
PTGO11	Trigger/Synchronization Source for IC4
PTGO12	Sample Trigger for ADC
PTGO13	Sample Trigger for ADC
PTGO14	Sample Trigger for ADC
PTGO15	Sample Trigger for ADC
PTGO16	PWM Time Base Synchronous Source for PWM
PTGO17	PWM Time Base Synchronous Source for PWM
PTGO18	Mask Input Select for Op Amp/Comparator
PTGO19	Mask Input Select for Op Amp/Comparator
PTGO20	Reserved
PTGO21	Reserved
PTGO22	Reserved
PTGO23	Reserved
PTGO24	Reserved
PTGO25	Reserved
PTGO26	Reserved
PTGO27	Reserved
PTGO28	Reserved
PTGO29	Reserved
PTGO30	PTG Output to PPS Input Selection
PTGO31	PTG Output to PPS Input Selection

26.0 OP AMP/COMPARATOR MODULE

Note 1: This data sheet summarizes the features of the dsPIC33EPXXXGM3XX/6XX/7XX family of devices. It is not intended to be a comprehensive reference source. To complement the information in this data sheet, refer to the “dsPIC33/PIC24 Family Reference Manual”, “Op Amp/Comparator” (DS70000357), which is available from the Microchip web site (www.microchip.com).

2: Some registers and associated bits described in this section may not be available on all devices. Refer to **Section 4.0 “Memory Organization”** in this data sheet for device-specific register and bit information.

The dsPIC33EPXXXGM3XX/6XX/7XX devices contain up to five comparators that can be configured in various ways. Comparators, CMP1, CMP2, CMP3 and CMP5, also have the option to be configured as op amps, with the output being brought to an external pin for gain/ filtering connections. As shown in **Figure 26-1**, individual comparator options are specified by the comparator module’s Special Function Register (SFR) control bits.

These options allow users to:

- Select the edge for trigger and interrupt generation
- Configure the comparator voltage reference
- Configure output blanking and masking
- Configure as a comparator or op amp (CMP1, CMP2, CMP3 and CMP5 only)

Note: Not all op amp/comparator input/output connections are available on all devices. See the “Pin Diagrams” section for available connections.

FIGURE 26-1: OP AMP/COMPARATOR x MODULE BLOCK DIAGRAM

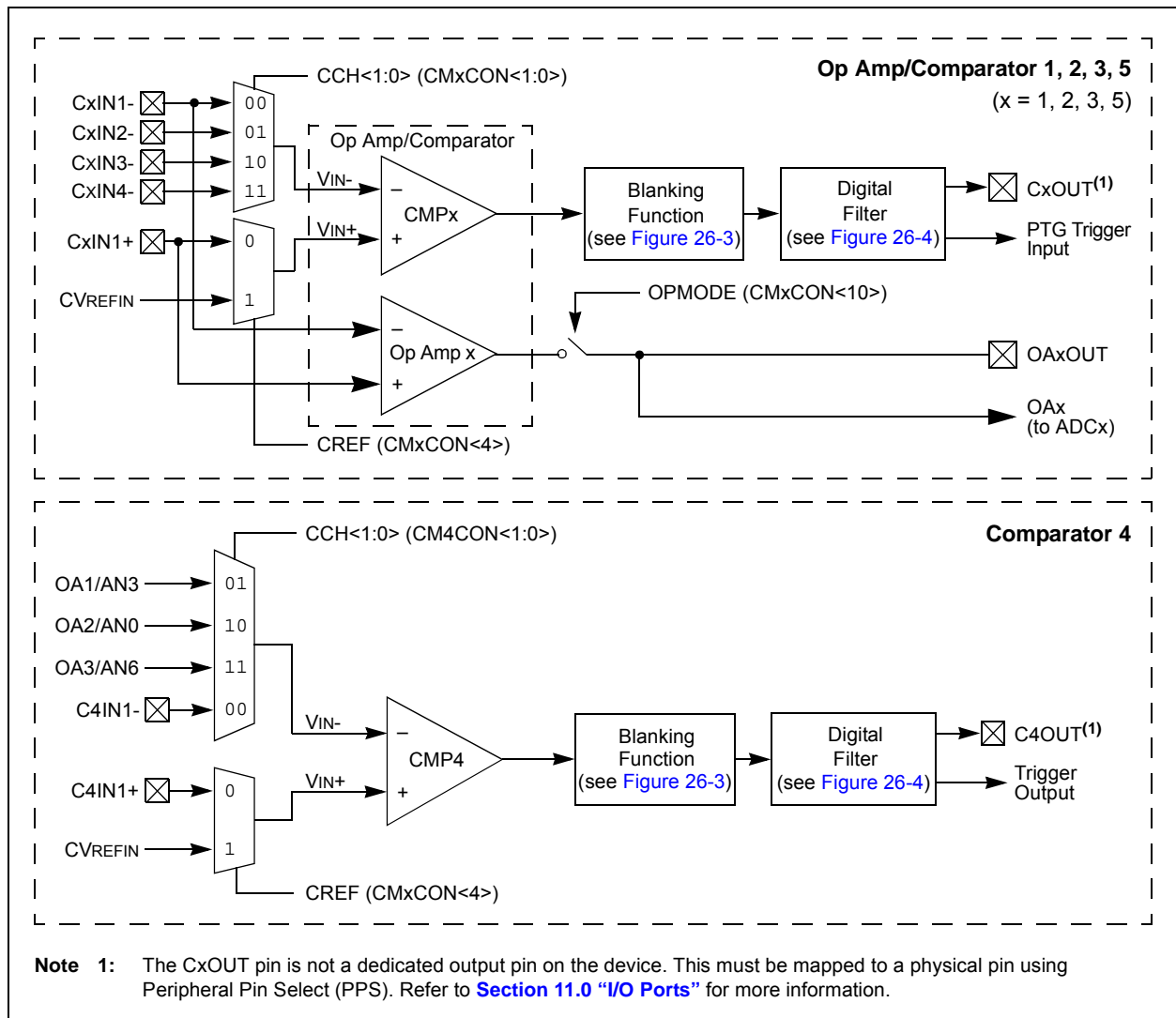

dsPIC33EPXXXGM3XX/6XX/7XX

FIGURE 26-2: OP AMP/COMPARATOR VOLTAGE REFERENCE BLOCK DIAGRAM

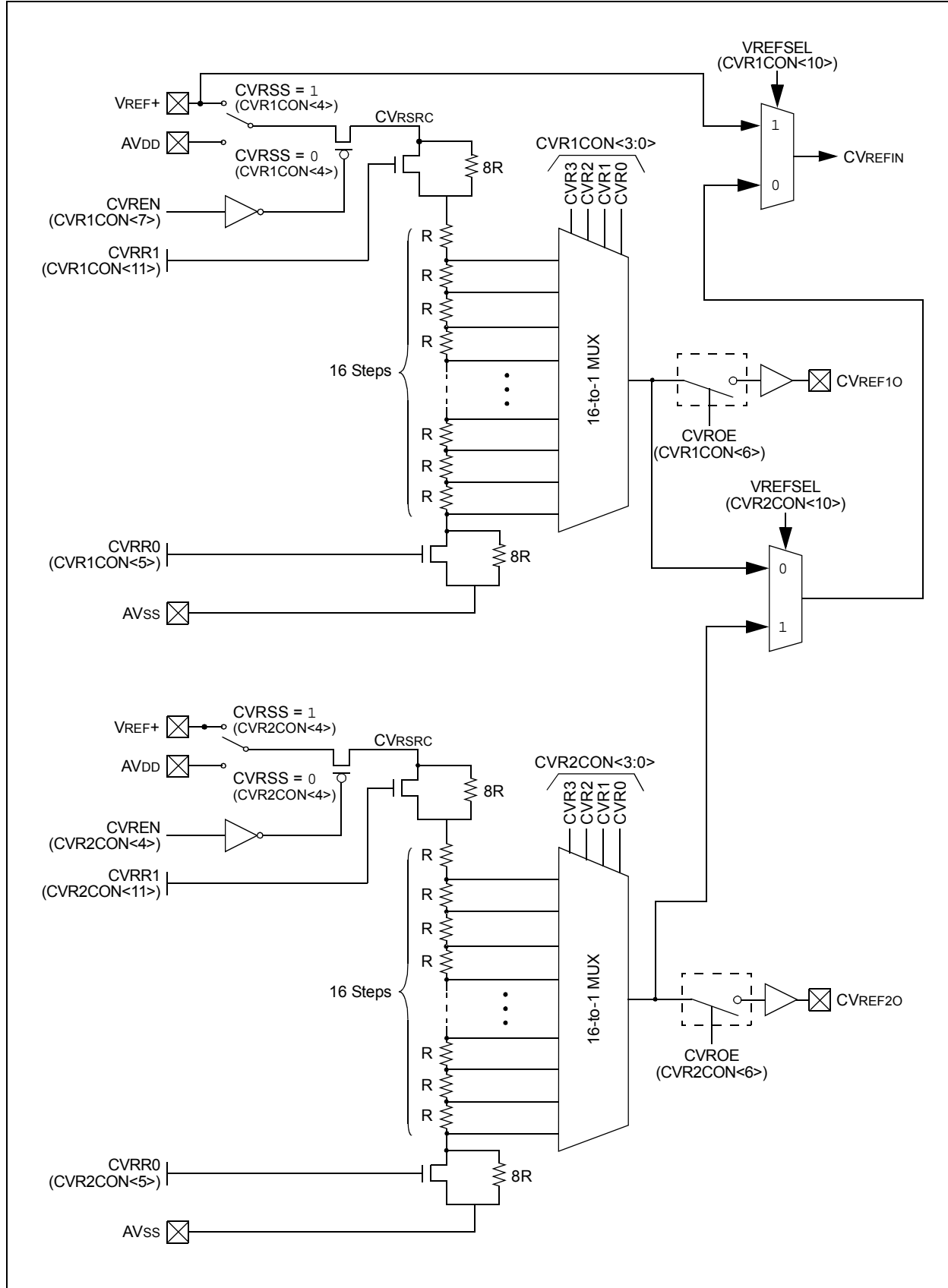

FIGURE 26-3: USER-PROGRAMMABLE BLANKING FUNCTION BLOCK DIAGRAM

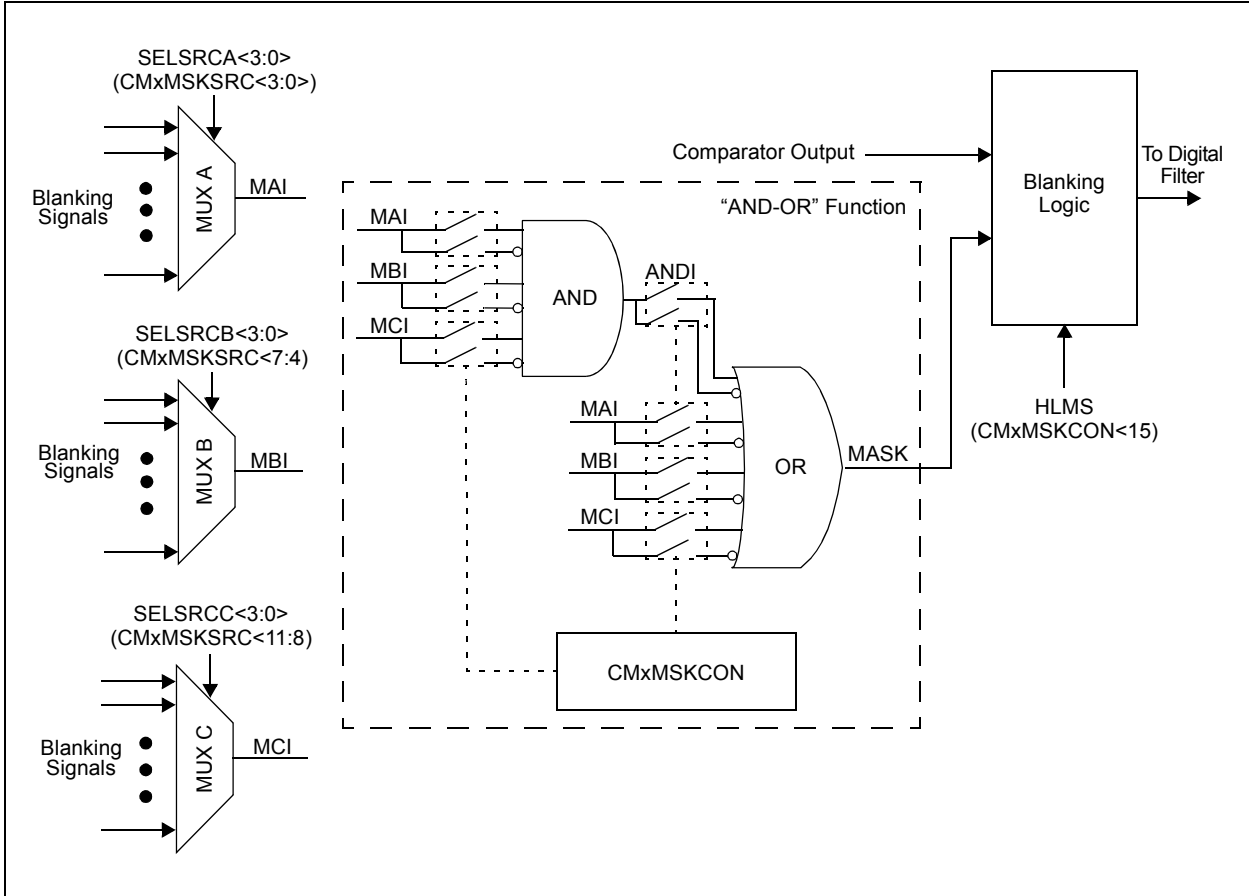
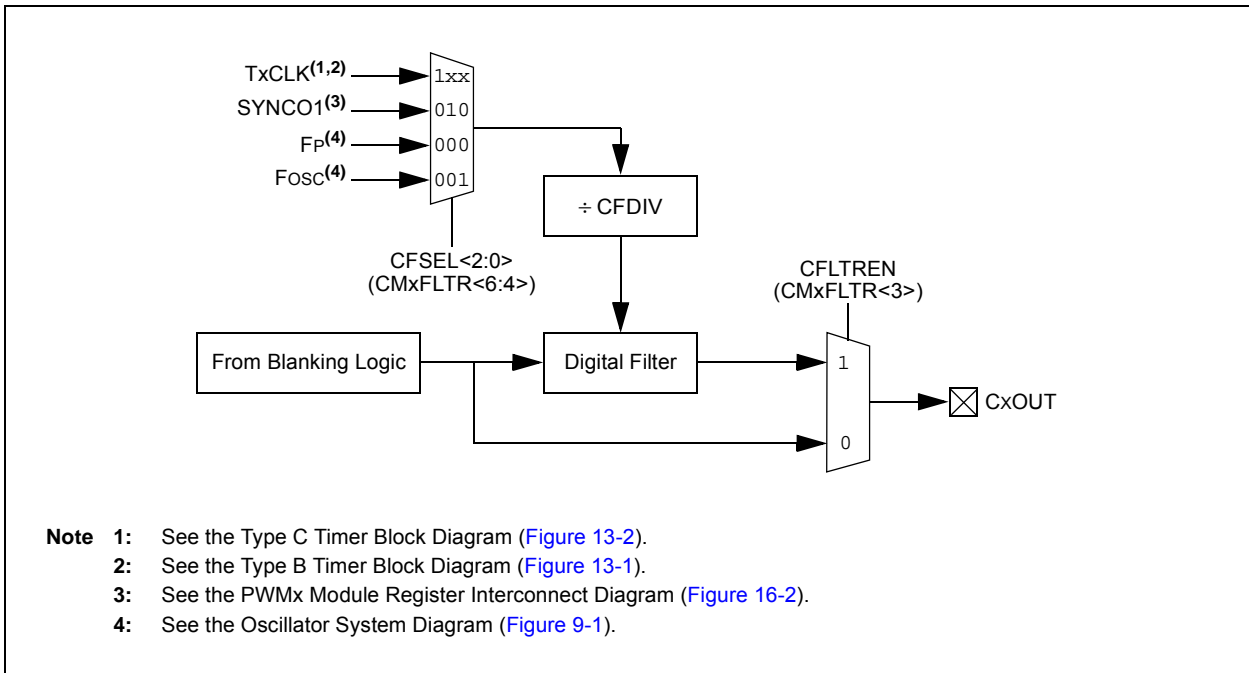

FIGURE 26-4: DIGITAL FILTER INTERCONNECT BLOCK DIAGRAM



26.1 Op Amp Application Considerations

There are two configurations to take into consideration when designing with the op amp modules that are available in the dsPIC33EPXXXGM3XX/6XX/7XX devices. Configuration A (see Figure 26-5) takes advantage of the internal connection to the ADCx module to route the output of the op amp directly to the ADCx for measurement. Configuration B (see Figure 26-6) requires that the designer externally route the output of the op amp (OAxOUT) to a separate analog input pin (ANy) on the device. Table 33-53 in Section 33.0 “Electrical Characteristics” describes the performance characteristics for the op amps, distinguishing between the two configuration types where applicable.

26.1.1 OP AMP CONFIGURATION A

Figure 26-5 shows a typical inverting amplifier circuit taking advantage of the internal connections from the op amp output to the input of the ADCx. The advantage of this configuration is that the user does not need to consume another analog input (ANy) on the device, and allows the user to simultaneously sample all three op amps with the ADCx module, if needed. However, the presence of the internal resistance, RINT1, adds an error in the feedback path. Since RINT1 is an internal resistance, in relation to the op amp output (VOAxOUT) and ADCx internal connection (VADC), RINT1 must be included in the numerator term of the transfer function. See Table 33-52 in Section 33.0 “Electrical Characteristics” for the typical value of RINT1. Table 33-57 and Table 33-58 in Section 33.0 “Electrical Characteristics” describe the minimum sample time (TSAMP) requirements for the ADCx module in this configuration. Figure 26-5 also defines the equations that should be used when calculating the expected voltages at points, VADC and VOAxOUT.

FIGURE 26-5: OP AMP CONFIGURATION A

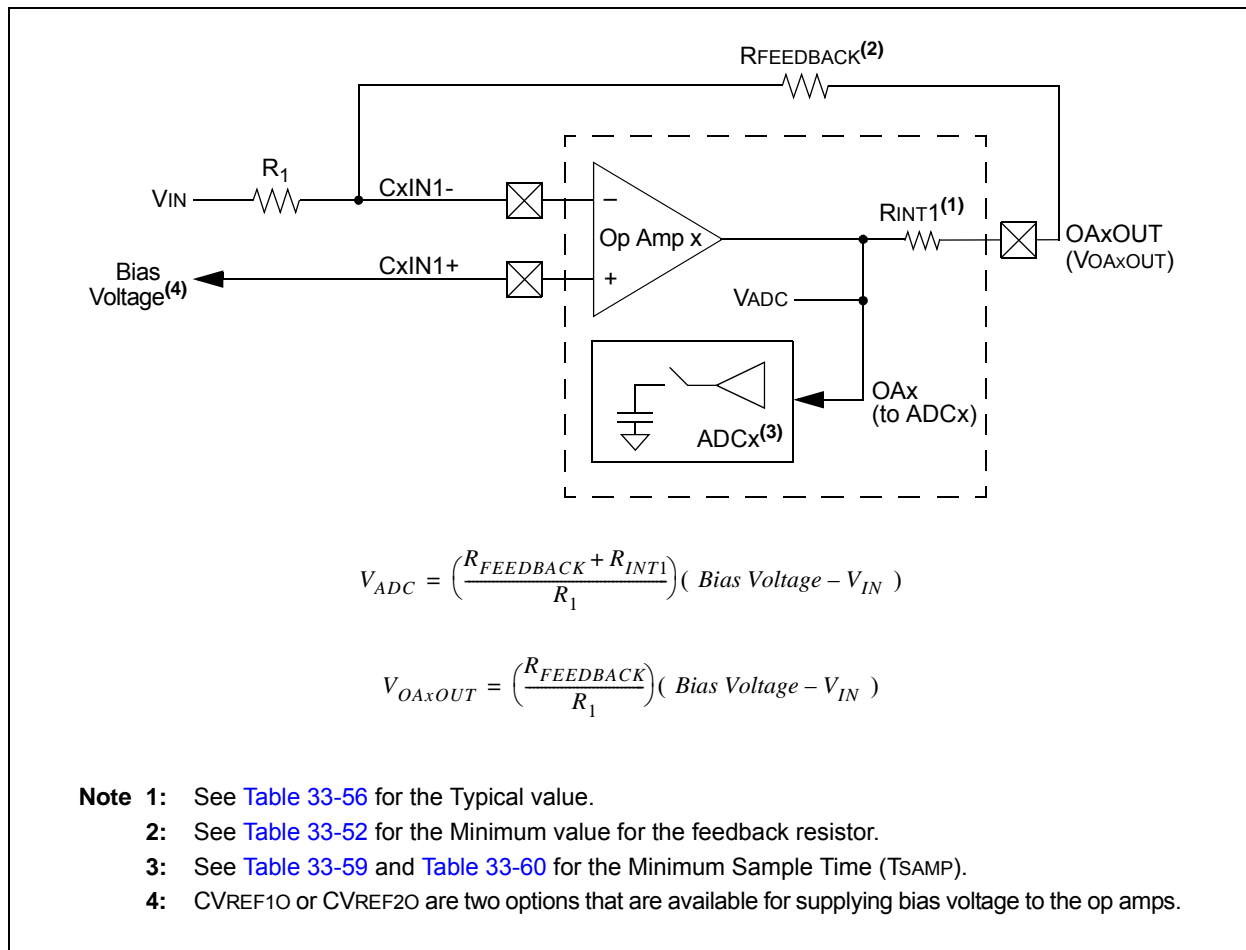

26.1.2 OP AMP CONFIGURATION B

Figure 26-6 shows a typical inverting amplifier circuit with the output of the op amp (OAxOUT) externally routed to a separate analog input pin (ANy) on the device. This op amp configuration is slightly different in terms of the op amp output and the ADCx input connection, therefore, RINT1 is not included in the transfer function. However, this configuration requires the designer to externally route the op amp output (OAxOUT) to another analog input pin (ANy). See Table 33-52 in Section 33.0 “Electrical Characteristics” for the typical value of RINT1. Table 33-57 and Table 33-58 in Section 33.0 “Electrical Characteristics” describe the minimum sample time (TSAMP) requirements for the ADCx module in this configuration.

Figure 26-6 also defines the equation to be used to calculate the expected voltage at point, VOAxOUT. This is the typical inverting amplifier equation.

26.2 Op Amp/Comparator Resources

Many useful resources are provided on the main product page of the Microchip web site for the devices listed in this data sheet. This product page, which can be accessed using this link, contains the latest updates and additional information.

Note: In the event you are not able to access the product page using the link above, enter this URL in your browser:
<http://www.microchip.com/wwwproducts/Devices.aspx?dDocName=en555464>

26.2.1 KEY RESOURCES

- “Op Amp/Comparator” (DS70000357) in the “dsPIC33/PIC24 Family Reference Manual”
- Code Samples
- Application Notes
- Software Libraries
- Webinars
- All Related “dsPIC33/PIC24 Family Reference Manual” Sections
- Development Tools

FIGURE 26-6: OP AMP CONFIGURATION B

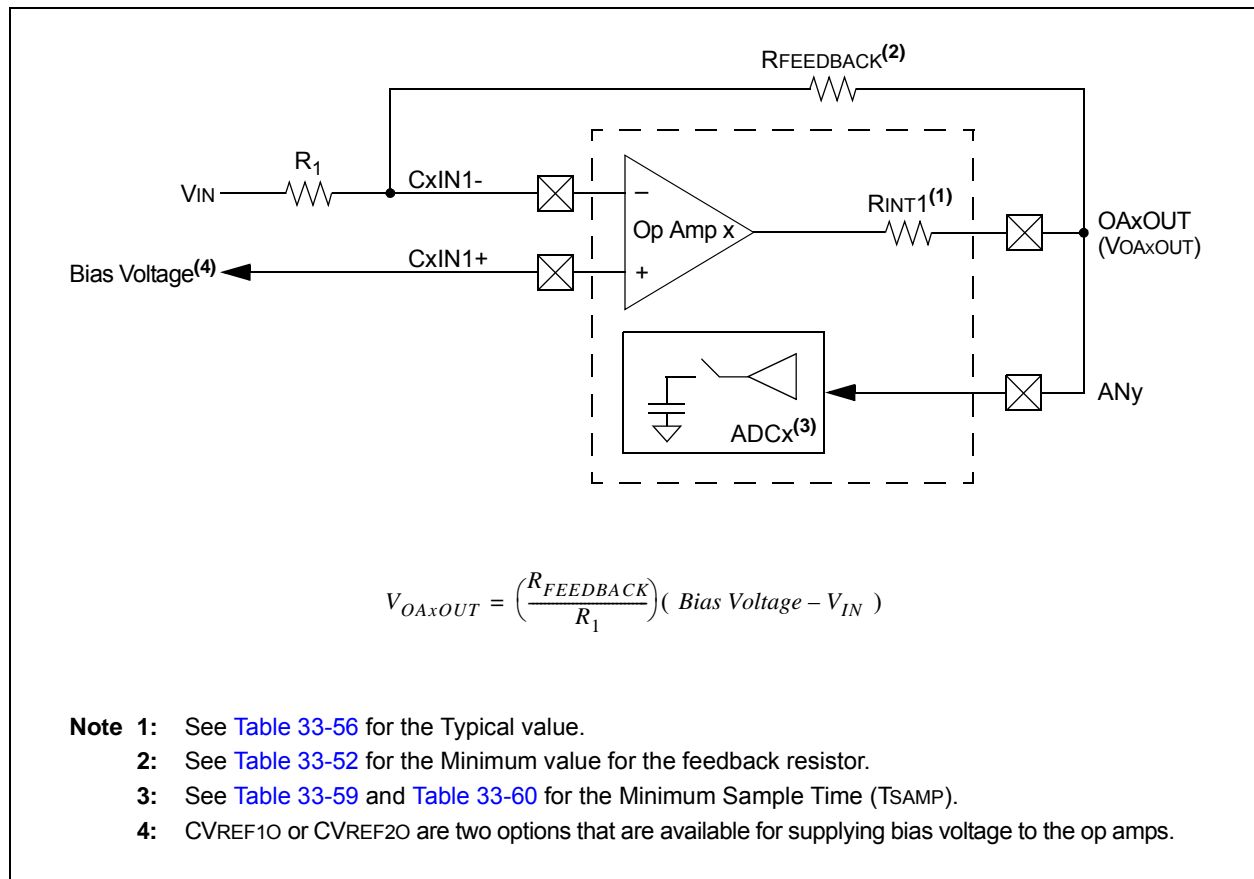

dsPIC33EPXXXGM3XX/6XX/7XX

26.3 Op Amp/Comparator Control Registers

REGISTER 26-1: CMSTAT: OP AMP/COMPARATOR STATUS REGISTER

R/W-0	U-0	U-0	R-0	R-0	R-0	R-0	R-0
PSIDL	—	—	C5EVT ⁽¹⁾	C4EVT ⁽¹⁾	C3EVT ⁽¹⁾	C2EVT ⁽¹⁾	C1EVT ⁽¹⁾
bit 15							bit 8

U-0	U-0	U-0	R-0	R-0	R-0	R-0	R-0
—	—	—	C5OUT ⁽²⁾	C4OUT ⁽²⁾	C3OUT ⁽²⁾	C2OUT ⁽²⁾	C1OUT ⁽²⁾
bit 7							bit 0

Legend:

R = Readable bit W = Writable bit U = Unimplemented bit, read as '0'
 -n = Value at POR '1' = Bit is set '0' = Bit is cleared x = Bit is unknown

bit 15 **PSIDL:** Op Amp/Comparator Stop in Idle Mode bit
 1 = Discontinues operation of all op amps/comparators when device enters Idle mode
 0 = Continues operation of all op amps/comparators in Idle mode

bit 14-13 **Unimplemented:** Read as '0'

bit 12 **C5EVT:C1EVT:** Op Amp/Comparator 1-5 Event Status bit⁽¹⁾
 1 = Op amp/comparator event occurred
 0 = Op amp/comparator event did not occur

bit 7-5 **Unimplemented:** Read as '0'

bit 4-0 **C5OUT:C1OUT:** Op Amp/Comparator 1-5 Output Status bit⁽²⁾
 When CPOL = 0:
 1 = VIN+ > VIN-
 0 = VIN+ < VIN-
 When CPOL = 1:
 1 = VIN+ < VIN-
 0 = VIN+ > VIN-

Note 1: Reflects the value of the of the CEVT bit in the respective Op Amp/Comparator x Control register, CMxCON<9>.
Note 2: Reflects the value of the COUT bit in the respective Op Amp/Comparator x Control register, CMxCON<8>.

REGISTER 26-2: CMxCON: OP AMP/COMPARATOR x CONTROL REGISTER (x = 1, 2, 3 OR 5)

R/W-0	R/W-0	R/W-0	U-0	U-0	R/W-0	R/W-0	R/W-0
CON	COE	CPOL	—	—	OPMODE ⁽²⁾	CEVT ⁽³⁾	COUT
bit 15							bit 8

R/W-0	R/W-0	U-0	R/W-0	U-0	U-0	R/W-0	R/W-0
EVPOL1 ⁽³⁾	EVPOL0 ⁽³⁾	—	CREF ⁽¹⁾	—	—	CCH1 ⁽¹⁾	CCH0 ⁽¹⁾
bit 7							bit 0

Legend:

R = Readable bit	W = Writable bit	U = Unimplemented bit, read as '0'
-n = Value at POR	'1' = Bit is set	'0' = Bit is cleared
		x = Bit is unknown

- bit 15 **CON:** Op Amp/Comparator Enable bit
1 = Comparator is enabled
0 = Comparator is disabled
- bit 14 **COE:** Comparator Output Enable bit
1 = Comparator output is present on the CxOUT pin
0 = Comparator output is internal only
- bit 13 **CPOL:** Comparator Output Polarity Select bit
1 = Comparator output is inverted
0 = Comparator output is not inverted
- bit 12-11 **Unimplemented:** Read as '0'
- bit 10 **OPMODE:** Op Amp Select bit⁽²⁾
1 = Op amp is enabled
0 = Op amp is disabled
- bit 9 **CEVT:** Comparator Event bit⁽³⁾
1 = Comparator event, according to the EVPOL<1:0> settings, occurred; disables future triggers and interrupts until the bit is cleared
0 = Comparator event did not occur
- bit 8 **COUT:** Comparator Output bit
When CPOL = 0 (non-inverted polarity):
1 = VIN+ > VIN-
0 = VIN+ < VIN-
When CPOL = 1 (inverted polarity):
1 = VIN+ < VIN-
0 = VIN+ > VIN-

- Note 1:** Inputs that are selected and not available will be tied to Vss. See the “Pin Diagrams” section for available inputs for each package.
- 2:** The op amp and the comparator can be used simultaneously in these devices. The OPMODE bit only enables the op amp while the comparator is still functional.
- 3:** After configuring the comparator, either for a high-to-low or low-to-high COUT transition (EVPOL<1:0> (CMxCON<7:6>) = 10 or 01), the Comparator Event bit, CEVT (CMxCON<9>), and the Comparator Combined Interrupt Flag, CMPIF (IFS1<2>), **must be cleared** before enabling the Comparator Interrupt Enable bit, CMPIE (IEC1<2>).

dsPIC33EPXXXGM3XX/6XX/7XX

REGISTER 26-2: CMxCON: OP AMP/COMPARATOR x CONTROL REGISTER (x = 1, 2, 3 OR 5) (CONTINUED)

- bit 7-6 **EVPOL<1:0>**: Trigger/Event/Interrupt Polarity Select bits⁽³⁾
- 11 = Trigger/event/interrupt generated on any change of the comparator output (while CEVT = 0)
 - 10 = Trigger/event/interrupt generated only on high-to-low transition of the polarity selected comparator output (while CEVT = 0)
 - If CPOL = 1 (inverted polarity):
Low-to-high transition of the comparator output.
 - If CPOL = 0 (non-inverted polarity):
High-to-low transition of the comparator output.
 - 01 = Trigger/event/interrupt generated only on low-to-high transition of the polarity selected comparator output (while CEVT = 0)
 - If CPOL = 1 (inverted polarity):
High-to-low transition of the comparator output.
 - If CPOL = 0 (non-inverted polarity):
Low-to-high transition of the comparator output.
 - 00 = Trigger/event/interrupt generation is disabled.
- bit 5 **Unimplemented**: Read as '0'
- bit 4 **CREF**: Comparator Reference Select bit (VIN+ input)⁽¹⁾
- 1 = VIN+ input connects to internal CVREFIN voltage
 - 0 = VIN+ input connects to CxIN1+ pin
- bit 3-2 **Unimplemented**: Read as '0'
- bit 1-0 **CCH<1:0>**: Op Amp/Comparator Channel Select bits⁽¹⁾
- 11 = Inverting input of op amp/comparator connects to CxIN4- pin
 - 10 = Inverting input of op amp/comparator connects to CxIN3- pin
 - 01 = Inverting input of op amp/comparator connects to CxIN2- pin
 - 00 = Inverting input of op amp/comparator connects to CxIN1- pin

- Note 1:** Inputs that are selected and not available will be tied to Vss. See the “[Pin Diagrams](#)” section for available inputs for each package.
- 2:** The op amp and the comparator can be used simultaneously in these devices. The OPMODE bit only enables the op amp while the comparator is still functional.
- 3:** After configuring the comparator, either for a high-to-low or low-to-high COUT transition (EVPOL<1:0> (CMxCON<7:6>) = 10 or 01), the Comparator Event bit, CEVT (CMxCON<9>), and the Comparator Combined Interrupt Flag, CMPIF (IFS1<2>), **must be cleared** before enabling the Comparator Interrupt Enable bit, CMPIE (IEC1<2>).

REGISTER 26-3: CM4CON: OP AMP/COMPARATOR 4 CONTROL REGISTER

R/W-0	R/W-0	R/W-0	U-0	U-0	U-0	R/W-0	R/W-0
CON	COE	CPOL	—	—	—	CEVT ⁽²⁾	COUT
bit 15						bit 8	

R/W-0	R/W-0	U-0	R/W-0	U-0	U-0	R/W-0	R/W-0
EVPOL1 ⁽²⁾	EVPOL0 ⁽²⁾	—	CREF ⁽¹⁾	—	—	CCH1 ⁽¹⁾	CCH0 ⁽¹⁾
bit 7						bit 0	

Legend:

R = Readable bit	W = Writable bit	U = Unimplemented bit, read as '0'
-n = Value at POR	'1' = Bit is set	'0' = Bit is cleared
		x = Bit is unknown

- bit 15 **CON:** Op Amp/Comparator Enable bit
 1 = Comparator is enabled
 0 = Comparator is disabled

- bit 14 **COE:** Comparator Output Enable bit
 1 = Comparator output is present on the CxOUT pin
 0 = Comparator output is internal only

- bit 13 **CPOL:** Comparator Output Polarity Select bit
 1 = Comparator output is inverted
 0 = Comparator output is not inverted

- bit 12-10 **Unimplemented:** Read as '0'

- bit 9 **CEVT:** Comparator Event bit⁽²⁾
 1 = Comparator event, according to the EVPOL<1:0> settings, occurred; disables future triggers and
 interrupts until the bit is cleared
 0 = Comparator event did not occur

- bit 8 **COUT:** Comparator Output bit
 When CPOL = 0 (non-inverted polarity):
 1 = $V_{IN+} > V_{IN-}$
 0 = $V_{IN+} < V_{IN-}$
 When CPOL = 1 (inverted polarity):
 1 = $V_{IN+} < V_{IN-}$
 0 = $V_{IN+} > V_{IN-}$

- Note 1:** Inputs that are selected and not available will be tied to Vss. See the “Pin Diagrams” section for available inputs for each package.
- 2:** After configuring the comparator, either for a high-to-low or low-to-high COUT transition (EVPOL<1:0> (CMxCON<7:6>) = 10 or 01), the Comparator Event bit, CEVT (CMxCON<9>), and the Comparator Combined Interrupt Flag, CMPIF (IFS1<2>), **must be cleared** before enabling the Comparator Interrupt Enable bit, CMPIE (IEC1<2>).

REGISTER 26-3: CM4CON: OP AMP/COMPARATOR 4 CONTROL REGISTER (CONTINUED)

- bit 7-6 **EVPOL<1:0>**: Trigger/Event/Interrupt Polarity Select bits⁽²⁾
- 11 = Trigger/event/interrupt generated on any change of the comparator output (while CEVT = 0)
 - 10 = Trigger/event/interrupt generated only on high-to-low transition of the polarity selected comparator output (while CEVT = 0)
 - If CPOL = 1 (inverted polarity):
Low-to-high transition of the comparator output.
 - If CPOL = 0 (non-inverted polarity):
High-to-low transition of the comparator output.
 - 01 = Trigger/event/interrupt generated only on low-to-high transition of the polarity selected comparator output (while CEVT = 0)
 - If CPOL = 1 (inverted polarity):
High-to-low transition of the comparator output.
 - If CPOL = 0 (non-inverted polarity):
Low-to-high transition of the comparator output.
 - 00 = Trigger/event/interrupt generation is disabled
- bit 5 **Unimplemented**: Read as '0'
- bit 4 **CREF**: Comparator Reference Select bit (VIN+ input)⁽¹⁾
- 1 = VIN+ input connects to internal CVREFIN voltage
 - 0 = VIN+ input connects to C4IN1+ pin
- bit 3-2 **Unimplemented**: Read as '0'
- bit 1-0 **CCH<1:0>**: Comparator Channel Select bits⁽¹⁾
- 11 = VIN- input of comparator connects to OA3/AN6
 - 10 = VIN- input of comparator connects to OA2/AN0
 - 01 = VIN- input of comparator connects to OA1/AN3
 - 00 = VIN- input of comparator connects to C4IN1-

- Note 1:** Inputs that are selected and not available will be tied to VSS. See the “[Pin Diagrams](#)” section for available inputs for each package.
- 2:** After configuring the comparator, either for a high-to-low or low-to-high COUT transition (EVPOL<1:0> (CMxCON<7:6>) = 10 or 01), the Comparator Event bit, CEVT (CMxCON<9>), and the Comparator Combined Interrupt Flag, CMPIF (IFS1<2>), **must be cleared** before enabling the Comparator Interrupt Enable bit, CMPIE (IEC1<2>).

REGISTER 26-4: CMxMSKSRC: COMPARATOR x MASK SOURCE SELECT CONTROL REGISTER

U-0	U-0	U-0	U-0	R/W-0	R/W-0	R/W-0	RW-0
—	—	—	—	SELSRCC3	SELSRCC2	SELSRCC1	SELSRCC0
bit 15							bit 8

R/W-0	R/W-0	R/W-0	R/W-0	R/W-0	R/W-0	R/W-0	R/W-0
SELSRCB3	SELSRCB2	SELSRCB1	SELSRCB0	SELSRCA3	SELSRCA2	SELSRCA1	SELSRCA0
bit 7							bit 0

Legend:			
R = Readable bit	W = Writable bit	U = Unimplemented bit, read as '0'	
-n = Value at POR	'1' = Bit is set	'0' = Bit is cleared	x = Bit is unknown

- bit 15-12 **Unimplemented:** Read as '0'
- bit 11-8 **SELSRCC<3:0>:** Mask C Input Select bits
 - 1111 = FLT4
 - 1110 = FLT2
 - 1101 = PTGO19
 - 1100 = PTGO18
 - 1011 = PWM6H
 - 1010 = PWM6L
 - 1001 = PWM5H
 - 1000 = PWM5L
 - 0111 = PWM4H
 - 0110 = PWM4L
 - 0101 = PWM3H
 - 0100 = PWM3L
 - 0011 = PWM2H
 - 0010 = PWM2L
 - 0001 = PWM1H
 - 0000 = PWM1L
- bit 7-4 **SELSRCB<3:0>:** Mask B Input Select bits
 - 1111 = FLT4
 - 1110 = FLT2
 - 1101 = PTGO19
 - 1100 = PTGO18
 - 1011 = PWM6H
 - 1010 = PWM6L
 - 1001 = PWM5H
 - 1000 = PWM5L
 - 0111 = PWM4H
 - 0110 = PWM4L
 - 0101 = PWM3H
 - 0100 = PWM3L
 - 0011 = PWM2H
 - 0010 = PWM2L
 - 0001 = PWM1H
 - 0000 = PWM1L

dsPIC33EPXXXGM3XX/6XX/7XX

REGISTER 26-4: CMxMSKSRCA: COMPARATOR x MASK SOURCE SELECT CONTROL REGISTER (CONTINUED)

bit 3-0 **SELSRCA<3:0>**: Mask A Input Select bits

1111 = FLT4
1110 = FLT2
1101 = PTGO19
1100 = PTGO18
1011 = PWM6H
1010 = PWM6L
1001 = PWM5H
1000 = PWM5L
0111 = PWM4H
0110 = PWM4L
0101 = PWM3H
0100 = PWM3L
0011 = PWM2H
0010 = PWM2L
0001 = PWM1H
0000 = PWM1L

REGISTER 26-5: CMxMSKCON: COMPARATOR x MASK GATING CONTROL REGISTER

R/W-0	U-0	R/W-0	R/W-0	R/W-0	R/W-0	R/W-0	R/W-0
HLMS	—	OCEN	OCNEN	OBEN	OBNEN	OAEN	OANEN
bit 15							bit 8

R/W-0	R/W-0	R/W-0	R/W-0	R/W-0	R/W-0	R/W-0	R/W-0
NAGS	PAGS	ACEN	ACNEN	ABEN	ABNEN	AAEN	AANEN
bit 7							bit 0

Legend:

R = Readable bit	W = Writable bit	U = Unimplemented bit, read as '0'
-n = Value at POR	'1' = Bit is set	'0' = Bit is cleared
		x = Bit is unknown

- bit 15 **HLMS:** High or Low-Level Masking Select bit
 1 = The masking (blinking) function will prevent any asserted ('0') comparator signal from propagating
 0 = The masking (blinking) function will prevent any asserted ('1') comparator signal from propagating
- bit 14 **Unimplemented:** Read as '0'
- bit 13 **OCEN:** OR Gate C Input Enable bit
 1 = MCI is connected to the OR gate
 0 = MCI is not connected to the OR gate
- bit 12 **OCNEN:** OR Gate C Input Inverted Enable bit
 1 = Inverted MCI is connected to the OR gate
 0 = Inverted MCI is not connected to the OR gate
- bit 11 **OBEN:** OR Gate B Input Enable bit
 1 = MBI is connected to the OR gate
 0 = MBI is not connected to the OR gate
- bit 10 **OBNEN:** OR Gate B Input Inverted Enable bit
 1 = Inverted MBI is connected to the OR gate
 0 = Inverted MBI is not connected to the OR gate
- bit 9 **OAEN:** OR Gate A Input Enable bit
 1 = MAI is connected to the OR gate
 0 = MAI is not connected to the OR gate
- bit 8 **OANEN:** OR Gate A Input Inverted Enable bit
 1 = Inverted MAI is connected to the OR gate
 0 = Inverted MAI is not connected to the OR gate
- bit 7 **NAGS:** AND Gate Output Inverted Enable bit
 1 = Inverted ANDI is connected to the OR gate
 0 = Inverted ANDI is not connected to the OR gate
- bit 6 **PAGS:** AND Gate Output Enable bit
 1 = ANDI is connected to the OR gate
 0 = ANDI is not connected to the OR gate
- bit 5 **ACEN:** AND Gate C Input Enable bit
 1 = MCI is connected to the AND gate
 0 = MCI is not connected to the AND gate
- bit 4 **ACNEN:** AND Gate C Input Inverted Enable bit
 1 = Inverted MCI is connected to the AND gate
 0 = Inverted MCI is not connected to the AND gate

dsPIC33EPXXXGM3XX/6XX/7XX

REGISTER 26-5: CMxMSKCON: COMPARATOR x MASK GATING CONTROL REGISTER (CONTINUED)

- bit 3 **ABEN:** AND Gate B Input Enable bit
1 = MBI is connected to the AND gate
0 = MBI is not connected to the AND gate
- bit 2 **ABNEN:** AND Gate B Input Inverted Enable bit
1 = Inverted MBI is connected to the AND gate
0 = Inverted MBI is not connected to the AND gate
- bit 1 **AAEN:** AND Gate A Input Enable bit
1 = MAI is connected to the AND gate
0 = MAI is not connected to the AND gate
- bit 0 **AANEN:** AND Gate A Input Inverted Enable bit
1 = Inverted MAI is connected to the AND gate
0 = Inverted MAI is not connected to the AND gate

REGISTER 26-6: CM_xFLTR: COMPARATOR x FILTER CONTROL REGISTER

U-0	U-0	U-0	U-0	U-0	U-0	U-0	U-0
—	—	—	—	—	—	—	—
bit 15							bit 8

U-0	R/W-0	R/W-0	R/W-0	R/W-0	R/W-0	R/W-0	R/W-0
—	CFSEL2	CFSEL1	CFSEL0	CFLTREN	CFDIV2	CFDIV1	CFDIV0
bit 7							bit 0

Legend:			
R = Readable bit	W = Writable bit	U = Unimplemented bit, read as '0'	
-n = Value at POR	'1' = Bit is set	'0' = Bit is cleared	x = Bit is unknown

- bit 15-7 **Unimplemented:** Read as '0'
- bit 6-4 **CFSEL<2:0>:** Comparator Filter Input Clock Select bits
 - 111 = T5CLK⁽¹⁾
 - 110 = T4CLK⁽²⁾
 - 101 = T3CLK⁽¹⁾
 - 100 = T2CLK⁽²⁾
 - 011 = SYNCO2
 - 010 = SYNCO1⁽³⁾
 - 001 = Fosc⁽⁴⁾
 - 000 = Fp⁽⁴⁾
- bit 3 **CFLTREN:** Comparator Filter Enable bit
 - 1 = Digital filter is enabled
 - 0 = Digital filter is disabled
- bit 2-0 **CFDIV<2:0>:** Comparator Filter Clock Divide Select bits
 - 111 = Clock Divide 1:128
 - 110 = Clock Divide 1:64
 - 101 = Clock Divide 1:32
 - 100 = Clock Divide 1:16
 - 011 = Clock Divide 1:8
 - 010 = Clock Divide 1:4
 - 001 = Clock Divide 1:2
 - 000 = Clock Divide 1:1

- Note 1:** See the Type C Timer Block Diagram (Figure 13-2).
Note 2: See the Type B Timer Block Diagram (Figure 13-1).
Note 3: See the PWMx Module Register Interconnect Diagram (Figure 16-2).
Note 4: See the Oscillator System Diagram (Figure 9-1).

dsPIC33EPXXXGM3XX/6XX/7XX

REGISTER 26-7: CVR1CON: COMPARATOR VOLTAGE REFERENCE CONTROL REGISTER 1

U-0	U-0	U-0	U-0	R/W-0	R/W-0	U-0	U-0
—	—	—	—	CVRR1	VREFSEL	—	—
bit 15				bit 8			

R/W-0	R/W-0	R/W-0	R/W-0	R/W-0	R/W-0	R/W-0	R/W-0
CVREN	CVROE	CVRR0	CVRSS	CVR3	CVR2	CVR1	CVR0
bit 7						bit 0	

Legend:

R = Readable bit W = Writable bit U = Unimplemented bit, read as '0'
 -n = Value at POR '1' = Bit is set '0' = Bit is cleared x = Bit is unknown

- bit 15-12 **Unimplemented:** Read as '0'
- bit 11 **CVRR1:** Comparator Voltage Reference Range Selection bit
See bit 5.
- bit 10 **VREFSEL:** Voltage Reference Select bit
1 = CVREFIN = VREF+
0 = CVREFIN is generated by the resistor network
- bit 9-8 **Unimplemented:** Read as '0'
- bit 7 **CVREN:** Comparator Voltage Reference Enable bit
1 = Comparator voltage reference circuit is powered on
0 = Comparator voltage reference circuit is powered down
- bit 6 **CVROE:** Comparator Voltage Reference Output Enable on CVREF10 Pin bit
1 = Voltage level is output on the CVREF10 pin
0 = Voltage level is disconnected from the CVREF10 pin
- bit 11, 5 **CVRR<1:0>:** Comparator Voltage Reference Range Selection bits
11 = 0.00 CVRSRC to 0.94, with CVRSRC/16 step-size
10 = 0.33 CVRSRC to 0.96, with CVRSRC/24 step-size
01 = 0.00 CVRSRC to 0.67, with CVRSRC/24 step-size
00 = 0.25 CVRSRC to 0.75, with CVRSRC/32 step-size
- bit 4 **CVRSS:** Comparator Voltage Reference Source Selection bit
1 = Comparator voltage reference source, CVRSRC = CVREF+ – AVSS
0 = Comparator voltage reference source, CVRSRC = AVDD – AVSS
- bit 3-0 **CVR<3:0>** Comparator Voltage Reference Value Selection $0 \leq \text{CVR<3:0>} \leq 15$ bits
 When CVRR<1:0> = 11:
 $\text{CVREF} = (\text{CVR<3:0>/16}) \cdot (\text{CVRSRC})$
 When CVRR<1:0> = 10:
 $\text{CVREF} = (1/3) \cdot (\text{CVRSRC}) + (\text{CVR<3:0>/24}) \cdot (\text{CVRSRC})$
 When CVRR<1:0> = 01:
 $\text{CVREF} = (\text{CVR<3:0>/24}) \cdot (\text{CVRSRC})$
 When CVRR<1:0> = 00:
 $\text{CVREF} = (1/4) \cdot (\text{CVRSRC}) + (\text{CVR<3:0>/32}) \cdot (\text{CVRSRC})$

REGISTER 26-8: CVR2CON: COMPARATOR VOLTAGE REFERENCE CONTROL REGISTER 2

U-0	U-0	U-0	U-0	R/W-0	R/W-0	U-0	U-0
—	—	—	—	CVRR1	VREFSEL	—	—
bit 15						bit 8	

R/W-0	R/W-0	R/W-0	R/W-0	R/W-0	R/W-0	R/W-0	R/W-0
CVREN	CVROE	CVRR0	CVRSS	CVR3	CVR2	CVR1	CVR0
bit 7						bit 0	

Legend:			
R = Readable bit	W = Writable bit	U = Unimplemented bit, read as '0'	
-n = Value at POR	'1' = Bit is set	'0' = Bit is cleared	x = Bit is unknown

- bit 15-12 **Unimplemented:** Read as '0'
- bit 11 **CVRR1:** Comparator Voltage Reference Range Selection bit
See bit 5.
- bit 10 **VREFSEL:** Voltage Reference Select bit
1 = Reference source for inverting input is from CVR2
0 = Reference source for inverting input is from CVR1
- bit 9-8 **Unimplemented:** Read as '0'
- bit 7 **CVREN:** Comparator Voltage Reference Enable bit
1 = Comparator voltage reference circuit is powered on
0 = Comparator voltage reference circuit is powered down
- bit 6 **CVROE:** Comparator Voltage Reference Output Enable on CVREF2O Pin bit
1 = Voltage level is output on the CVREF2O pin
0 = Voltage level is disconnected from the CVREF2O pin
- bit 11, 5 **CVRR<1:0>:** Comparator Voltage Reference Range Selection bits
11 = 0.00 CVRSRC to 0.94, with CVRSRC/16 step-size
10 = 0.33 CVRSRC to 0.96, with CVRSRC/24 step-size
01 = 0.00 CVRSRC to 0.67, with CVRSRC/24 step-size
00 = 0.25 CVRSRC to 0.75, with CVRSRC/32 step-size
- bit 4 **CVRSS:** Comparator Voltage Reference Source Selection bit
1 = Comparator voltage reference source, CVRSRC = CVREF+ – AVSS
0 = Comparator voltage reference source, CVRSRC = AVDD – AVSS
- bit 3-0 **CVR<3:0>** Comparator Voltage Reference Value Selection $0 \leq \text{CVR<3:0>} \leq 15$ bits
 When CVRR<1:0> = 11:

$$\text{CVREF} = (\text{CVR<3:0>/16}) \bullet (\text{CVRSRC})$$
 When CVRR<1:0> = 10:

$$\text{CVREF} = (1/3) \bullet (\text{CVRSRC}) + (\text{CVR<3:0>/24}) \bullet (\text{CVRSRC})$$
 When CVRR<1:0> = 01:

$$\text{CVREF} = (\text{CVR<3:0>/24}) \bullet (\text{CVRSRC})$$
 When CVRR<1:0> = 00:

$$\text{CVREF} = (1/4) \bullet (\text{CVRSRC}) + (\text{CVR<3:0>/32}) \bullet (\text{CVRSRC})$$

dsPIC33EPXXGM3XX/6XX/7XX

NOTES:

27.0 REAL-TIME CLOCK AND CALENDAR (RTCC)

Note 1: This data sheet summarizes the features of the dsPIC33EPXXXGM3XX/6XX/7XX families of devices. It is not intended to be a comprehensive reference source. To complement the information in this data sheet, refer to the “dsPIC33/PIC24 Family Reference Manual”, “**Real-Time Clock and Calendar (RTCC)**” (DS70584), which is available from the Microchip web site (www.microchip.com).

2: Some registers and associated bits described in this section may not be available on all devices. Refer to [Section 4.0 “Memory Organization”](#) in this data sheet for device-specific register and bit information.

This chapter discusses the Real-Time Clock and Calendar (RTCC) module and its operation.

Some of the key features of this module are:

- Time: Hours, Minutes and Seconds
- 24-Hour Format (military time)
- Calendar: Weekday, Date, Month and Year
- Alarm Configurable
- Year Range: 2000 to 2099
- Leap Year Correction
- BCD Format for Compact Firmware
- Optimized for Low-Power Operation
- User Calibration with Auto-Adjust
- Calibration Range: ± 2.64 Seconds Error per Month
- Requirements: External 32.768 kHz Clock Crystal
- Alarm Pulse or Seconds Clock Output on RTCC Pin

The RTCC module is intended for applications where accurate time must be maintained for extended periods with minimum to no intervention from the CPU. The RTCC module is optimized for low-power usage to provide extended battery lifetime while keeping track of time.

The RTCC module is a 100-year clock and calendar with automatic leap year detection. The range of the clock is from 00:00:00 (midnight) on January 1, 2000 to 23:59:59 on December 31, 2099.

The hours are available in 24-hour (military time) format. The clock provides a granularity of one second with half-second visibility to the user.

dsPIC33EPXXXGM3XX/6XX/7XX

FIGURE 27-1: RTCC BLOCK DIAGRAM

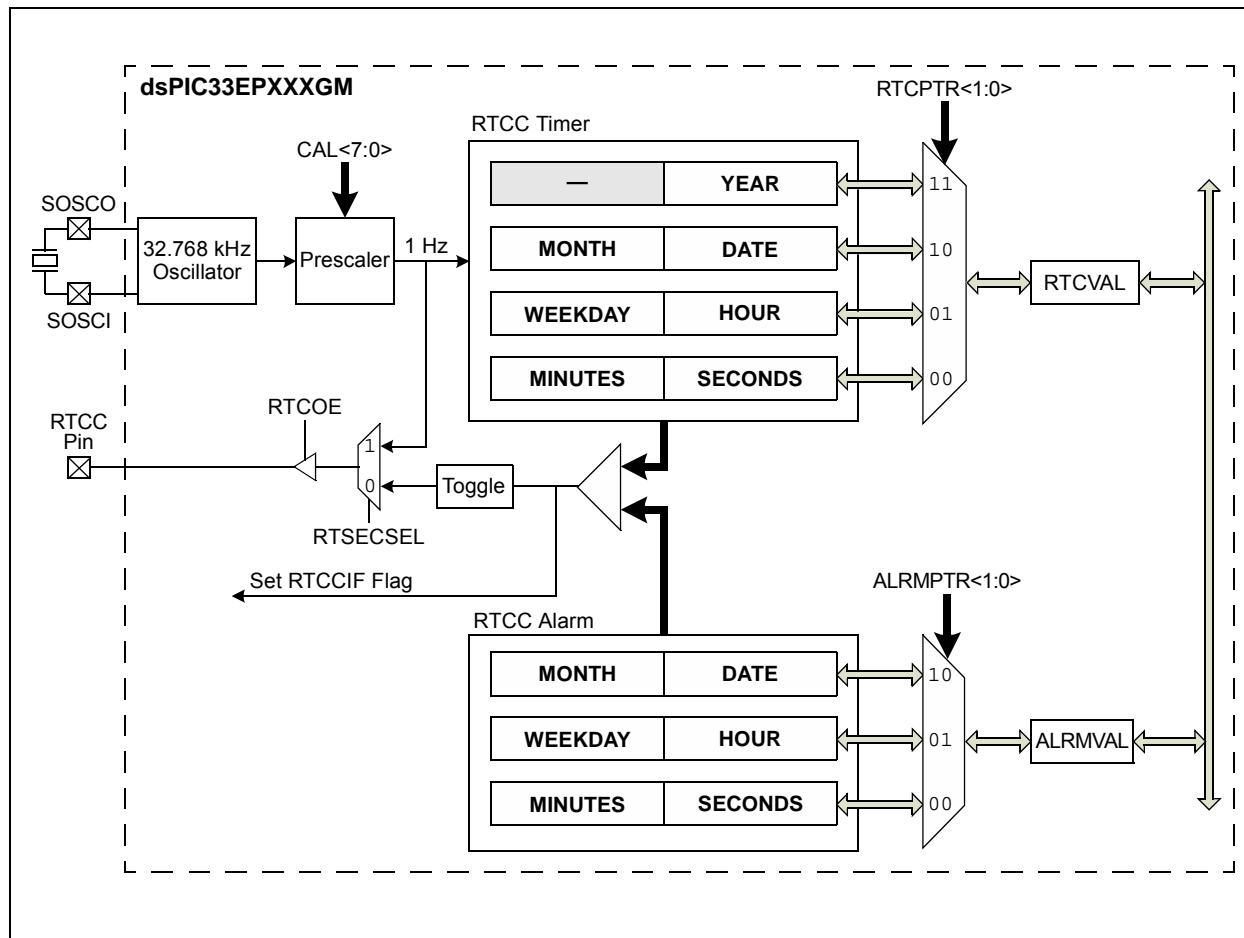

Note: The RTCC is only operational on devices which include the SOSC; therefore, the RTCC module is not available on 44-pin devices.

27.1 Writing to the RTCC Timer

Note: To allow the RTCC module to be clocked by the secondary crystal oscillator, the Secondary Oscillator Enable (LPOSCEN) bit in the Oscillator Control (OSCCON<1>) register must be set. For further details, refer to the “*dsPIC33/PIC24 Family Reference Manual*”, “**Oscillator**” (DS70580).

The user application can configure the time and calendar by writing the desired seconds, minutes, hours, weekday, date, month and year to the RTCC registers. Under normal operation, writes to the RTCC Timer registers are not allowed. Attempted writes will appear to execute normally, but the contents of the registers will remain unchanged. To write to the RTCC register, the RTCWREN bit (RCFGCAL<13>) must be set. Setting the RTCWREN bit allows writes to the RTCC registers. Conversely, clearing the RTCWREN bit prevents writes.

To set the RTCWREN bit, the following procedure must be executed. The RTCWREN bit can be cleared at any time:

1. Write 0x55 to NVMKEY.
2. Write 0xAA to NVMKEY.
3. Set the RTCWREN bit using a single-cycle instruction.

The RTCC module is enabled by setting the RTCEN bit (RCFGCAL<15>). To set or clear the RTCEN bit, the RTCWREN bit (RCFGCAL<13>) must be set.

If the entire clock (hours, minutes and seconds) needs to be corrected, it is recommended that the RTCC module should be disabled to avoid coincidental write operation when the timer increments. Therefore, it stops the clock from counting while writing to the RTCC Timer register.

27.2 RTCC Resources

Many useful resources related to RTCC are provided on the main product page of the Microchip web site for the devices listed in this data sheet. This product page, which can be accessed using this [link](#), contains the latest updates and additional information.

Note: In the event you are not able to access the product page using the link above, enter this URL in your browser:
<http://www.microchip.com/wwwproducts/Devices.aspx?dDocName=en554310>

27.2.1 KEY RESOURCES

- “**Real-Time Clock and Calendar (RTCC)**” (DS70584) in the “*dsPIC33/PIC24 Family Reference Manual*”
- Code Samples
- Application Notes
- Software Libraries
- Webinars
- All related “*dsPIC33/PIC24 Family Reference Manual*” Sections
- Development Tools

dsPIC33EPXXXGM3XX/6XX/7XX

27.3 RTCC Registers

REGISTER 27-1: RCFGAL: RTCC CALIBRATION AND CONFIGURATION REGISTER⁽¹⁾

R/W-0	U-0	R/W-0	R-0	R-0	R/W-0	R/W-0	R/W-0
RTCEN ⁽²⁾	—	RTCWREN	RTCSYNC	HALFSEC ⁽³⁾	RTCOE	RTCPTR1	RTCPTRO
bit 15							bit 8

R/W-0	R/W-0	R/W-0	R/W-0	R/W-0	R/W-0	R/W-0	R/W-0
CAL7	CAL6	CAL5	CAL4	CAL3	CAL2	CAL1	CAL0
bit 7							bit 0

Legend:

R = Readable bit	W = Writable bit	U = Unimplemented bit, read as '0'
-n = Value at POR	'1' = Bit is set	'0' = Bit is cleared x = Bit is unknown

- bit 15 **RTCEN:** RTCC Enable bit⁽²⁾
 1 = RTCC module is enabled
 0 = RTCC module is disabled
- bit 14 **Unimplemented:** Read as '0'
- bit 13 **RTCWREN:** RTCC Value Register Write Enable bit
 1 = RTCVAL register can be written to by the user application
 0 = RTCVAL register is locked out from being written to by the user application
- bit 12 **RTCSYNC:** RTCC Value Register Read Synchronization bit
 1 = A rollover is about to occur in 32 clock edges (approximately 1 ms)
 0 = A rollover will not occur
- bit 11 **HALFSEC:** Half-Second Status bit⁽³⁾
 1 = Second half period of a second
 0 = First half period of a second
- bit 10 **RTCOE:** RTCC Output Enable bit
 1 = RTCC output is enabled
 0 = RTCC output is disabled
- bit 9-8 **RTCPTR<1:0>:** RTCC Value Register Pointer bits
 Points to the corresponding RTCC Value register when reading the RTCVAL register; the RTCPTR<1:0> value decrements on every access of the RTCVAL register until it reaches '00'.
- bit 7-0 **CAL<7:0>:** RTCC Drift Calibration bits
 01111111 = Maximum positive adjustment; adds 508 RTCC clock pulses every one minute
 .
 .
 .
 00000001 = Minimum positive adjustment; adds 4 RTCC clock pulses every one minute
 00000000 = No adjustment
 11111111 = Minimum negative adjustment; subtracts 4 RTCC clock pulses every one minute
 .
 .
 .
 10000000 = Maximum negative adjustment; subtracts 512 RTCC clock pulses every one minute

- Note 1:** The RCFGAL register is only affected by a POR.
Note 2: A write to the RTCEN bit is only allowed when RTCWREN = 1.
Note 3: This bit is read-only. It is cleared when the lower half of the MINSEC register is written.

REGISTER 27-2: PADCFG1: PAD CONFIGURATION CONTROL REGISTER

U-0	U-0	U-0	U-0	U-0	U-0	U-0	U-0
—	—	—	—	—	—	—	—
bit 15							bit 8

U-0	U-0	U-0	U-0	U-0	U-0	R/W-0	R/W-0
—	—	—	—	—	—	RTSECSEL ⁽¹⁾	PMPTTL
bit 7							bit 0

Legend:

R = Readable bit	W = Writable bit	U = Unimplemented bit, read as '0'
-n = Value at POR	'1' = Bit is set	'0' = Bit is cleared x = Bit is unknown

- bit 15-2 **Unimplemented:** Read as '0'
- bit 1 **RTSECSEL:** RTCC Seconds Clock Output Select bit⁽¹⁾
 - 1 = RTCC seconds clock is selected for the RTCC pin
 - 0 = RTCC alarm pulse is selected for the RTCC pin
- bit 0 Not used by the RTCC module.

Note 1: To enable the actual RTCC output, the RTCOE bit (RCFGCAL<10>) must be set.

dsPIC33EPXXXGM3XX/6XX/7XX

REGISTER 27-3: ALCFGRPT: ALARM CONFIGURATION REGISTER

R/W-0	R/W-0	R/W-0	R/W-0	R/W-0	R/W-0	R/W-0	R/W-0
ALRMEN	CHIME	AMASK3	AMASK2	AMASK1	AMASK0	ALRMPTR1	ALRMPTR0
bit 15						bit 8	

R/W-0	R/W-0	R/W-0	R/W-0	R/W-0	R/W-0	R/W-0	R/W-0
ARPT7	ARPT6	ARPT5	ARPT4	ARPT3	ARPT2	ARPT1	ARPT0
bit 7						bit 0	

Legend:

R = Readable bit	W = Writable bit	U = Unimplemented bit, read as '0'
-n = Value at POR	'1' = Bit is set	'0' = Bit is cleared
		x = Bit is unknown

- bit 15 **ALRMEN:** Alarm Enable bit
 1 = Alarm is enabled (cleared automatically after an alarm event whenever ARPT<7:0> = 0x00 and CHIME = 0)
 0 = Alarm is disabled
- bit 14 **CHIME:** Chime Enable bit
 1 = Chime is enabled; ARPT<7:0> bits are allowed to roll over from 0x00 to 0xFF
 0 = Chime is disabled; ARPT<7:0> bits stop once they reach 0x00
- bit 13-10 **AMASK<3:0>:** Alarm Mask Configuration bits
 0000 = Every half second
 0001 = Every second
 0010 = Every 10 seconds
 0011 = Every minute
 0100 = Every 10 minutes
 0101 = Every hour
 0110 = Once a day
 0111 = Once a week
 1000 = Once a month
 1001 = Once a year (except when configured for February 29th, once every 4 years)
 101x = Reserved – do not use
 11xx = Reserved – do not use
- bit 9-8 **ALRMPTR<1:0>:** Alarm Value Register Window Pointer bits
 Points to the corresponding Alarm Value registers when reading the ALRMVAL register. The ALRMPTR<1:0> value decrements on every read or write of ALRMVAL until it reaches '00'.
- bit 7-0 **ARPT<7:0>:** Alarm Repeat Counter Value bits
 11111111 = Alarm will repeat 255 more times
 •
 •
 •
 00000000 = Alarm will not repeat
 The counter decrements on any alarm event. The counter is prevented from rolling over from 0x00 to 0xFF unless CHIME = 1.

dsPIC33EPXXXGM3XX/6XX/7XX

REGISTER 27-4: RTCVAL (WHEN RTCPTR<1:0> = 11): YEAR VALUE REGISTER⁽¹⁾

U-0	U-0	U-0	U-0	U-0	U-0	U-0	U-0
—	—	—	—	—	—	—	—
bit 15							bit 8

R/W-x	R/W-x	R/W-x	R/W-x	R/W-x	R/W-x	R/W-x	R/W-x
YRTEN3	YRTEN2	YRTEN1	YRTEN0	YRONE3	YRONE2	YRONE1	YRONE0
bit 7							bit 0

Legend:

R = Readable bit W = Writable bit U = Unimplemented bit, read as '0'
 -n = Value at POR '1' = Bit is set '0' = Bit is cleared x = Bit is unknown

- bit 15-8 **Unimplemented:** Read as '0'
- bit 7-4 **YRTEN<3:0>:** Binary Coded Decimal Value of Year's Tens Digit bits
Contains a value from 0 to 9.
- bit 3-0 **YRONE<3:0>:** Binary Coded Decimal Value of Year's Ones Digit bits
Contains a value from 0 to 9.

Note 1: A write to the YEAR register is only allowed when RTCWREN = 1.

REGISTER 27-5: RTCVAL (WHEN RTCPTR<1:0> = 10): MONTH AND DAY VALUE REGISTER⁽¹⁾

U-0	U-0	U-0	R-x	R-x	R-x	R-x	R-x
—	—	—	MHTTEN0	MTHONE3	MTHONE2	MTHONE1	MTHONE0
bit 15							bit 8

U-0	U-0	R/W-x	R/W-x	R/W-x	R/W-x	R/W-x	R/W-x
—	—	DAYTEN1	DAYTEN0	DAYONE3	DAYONE2	DAYONE1	DAYONE0
bit 7							bit 0

Legend:

R = Readable bit W = Writable bit U = Unimplemented bit, read as '0'
 -n = Value at POR '1' = Bit is set '0' = Bit is cleared x = Bit is unknown

- bit 15-13 **Unimplemented:** Read as '0'
- bit 12 **MHTTEN0:** Binary Coded Decimal Value of Month's Tens Digit bit
Contains a value of 0 or 1.
- bit 11-8 **MTHONE<3:0>:** Binary Coded Decimal Value of Month's Ones Digit bits
Contains a value from 0 to 9.
- bit 7-6 **Unimplemented:** Read as '0'
- bit 5-4 **DAYTEN<1:0>:** Binary Coded Decimal Value of Day's Tens Digit bits
Contains a value from 0 to 3.
- bit 3-0 **DAYONE<3:0>:** Binary Coded Decimal Value of Day's Ones Digit bits
Contains a value from 0 to 9.

Note 1: A write to this register is only allowed when RTCWREN = 1.

dsPIC33EPXXXGM3XX/6XX/7XX

REGISTER 27-6: RTCVAL (WHEN RTCPTR<1:0> = 01): WEEKDAY AND HOURS VALUE REGISTER⁽¹⁾

U-0	U-0	U-0	U-0	U-0	R/W-x	R/W-x	R/W-x
—	—	—	—	—	WDAY2	WDAY1	WDAY0
bit 15					bit 8		

U-0	U-0	R/W-x	R/W-x	R/W-x	R/W-x	R/W-x	R/W-x
—	—	HRTEN1	HRTEN0	HRONE3	HRONE2	HRONE1	HRONE0
bit 7		bit 0					

Legend:

R = Readable bit W = Writable bit U = Unimplemented bit, read as '0'
 -n = Value at POR '1' = Bit is set '0' = Bit is cleared x = Bit is unknown

- bit 15-11 **Unimplemented:** Read as '0'
- bit 10-8 **WDAY<2:0>:** Binary Coded Decimal Value of Weekday Digit bits
Contains a value from 0 to 6.
- bit 7-6 **Unimplemented:** Read as '0'
- bit 5-4 **HRTEN<1:0>:** Binary Coded Decimal Value of Hour's Tens Digit bits
Contains a value from 0 to 2.
- bit 3-0 **HRONE<3:0>:** Binary Coded Decimal Value of Hour's Ones Digit bits
Contains a value from 0 to 9.

Note 1: A write to this register is only allowed when RTCWREN = 1.

REGISTER 27-7: RTCVAL (WHEN RTCPTR<1:0> = 00): MINUTES AND SECONDS VALUE REGISTER

U-0	R/W-x	R/W-x	R/W-x	R/W-x	R/W-x	R/W-x	R/W-x
—	MINTEN2	MINTEN1	MINTEN0	MINONE3	MINONE2	MINONE1	MINONE0
bit 15					bit 8		

U-0	R/W-x	R/W-x	R/W-x	R/W-x	R/W-x	R/W-x	R/W-x
—	SECTEN2	SECTEN1	SECTEN0	SECONE3	SECONE2	SECONE1	SECONE0
bit 7		bit 0					

Legend:

R = Readable bit W = Writable bit U = Unimplemented bit, read as '0'
 -n = Value at POR '1' = Bit is set '0' = Bit is cleared x = Bit is unknown

- bit 15 **Unimplemented:** Read as '0'
- bit 14-12 **MINTEN<2:0>:** Binary Coded Decimal Value of Minute's Tens Digit bits
Contains a value from 0 to 5.
- bit 11-8 **MINONE<3:0>:** Binary Coded Decimal Value of Minute's Ones Digit bits
Contains a value from 0 to 9.
- bit 7 **Unimplemented:** Read as '0'
- bit 6-4 **SECTEN<2:0>:** Binary Coded Decimal Value of Second's Tens Digit bits
Contains a value from 0 to 5.
- bit 3-0 **SECONE<3:0>:** Binary Coded Decimal Value of Second's Ones Digit bits
Contains a value from 0 to 9.

REGISTER 27-8: ALRMVAL (WHEN ALRMPTR<1:0> = 10): ALARM MONTH AND DAY VALUE REGISTER⁽¹⁾

U-0	U-0	U-0	R/W-x	R/W-x	R/W-x	R/W-x	R/W-x
—	—	—	MHTTEN0	MTHONE3	MTHONE2	MTHONE1	MTHONE0
bit 15							bit 8

U-0	U-0	R/W-x	R/W-x	R/W-x	R/W-x	R/W-x	R/W-x
—	—	DAYTEN1	DAYTEN0	DAYONE3	DAYONE2	DAYONE1	DAYONE0
bit 7							bit 0

Legend:

R = Readable bit	W = Writable bit	U = Unimplemented bit, read as '0'	
-n = Value at POR	'1' = Bit is set	'0' = Bit is cleared	x = Bit is unknown

- bit 15-13 **Unimplemented:** Read as '0'
- bit 12 **MHTTEN0:** Binary Coded Decimal Value of Month's Tens Digit bit
Contains a value of 0 or 1.
- bit 11-8 **MTHONE<3:0>:** Binary Coded Decimal Value of Month's Ones Digit bits
Contains a value from 0 to 9.
- bit 7-6 **Unimplemented:** Read as '0'
- bit 5-4 **DAYTEN<1:0>:** Binary Coded Decimal Value of Day's Tens Digit bits
Contains a value from 0 to 3.
- bit 3-0 **DAYONE<3:0>:** Binary Coded Decimal Value of Day's Ones Digit bits
Contains a value from 0 to 9.

Note 1: A write to this register is only allowed when RTCWREN = 1.

dsPIC33EPXXXGM3XX/6XX/7XX

REGISTER 27-9: ALRMVAL (WHEN ALRMPTR<1:0> = 01): ALARM WEEKDAY AND HOURS VALUE REGISTER⁽¹⁾

U-0	U-0	U-0	U-0	U-0	R/W-x	R/W-x	R/W-x
—	—	—	—	—	WDAY2	WDAY1	WDAY0
bit 15					bit 8		

U-0	U-0	R/W-x	R/W-x	R/W-x	R/W-x	R/W-x	R/W-x
—	—	HRTEN1	HRTEN0	HRONE3	HRONE2	HRONE1	HRONE0
bit 7		bit 0					

Legend:

R = Readable bit W = Writable bit U = Unimplemented bit, read as '0'
 -n = Value at POR '1' = Bit is set '0' = Bit is cleared x = Bit is unknown

- bit 15-11 **Unimplemented:** Read as '0'
- bit 10-8 **WDAY<2:0>:** Binary Coded Decimal Value of Weekday Digit bits
Contains a value from 0 to 6.
- bit 7-6 **Unimplemented:** Read as '0'
- bit 5-4 **HRTEN<1:0>:** Binary Coded Decimal Value of Hour's Tens Digit bits
Contains a value from 0 to 2.
- bit 3-0 **HRONE<3:0>:** Binary Coded Decimal Value of Hour's Ones Digit bits
Contains a value from 0 to 9.

Note 1: A write to this register is only allowed when RTCWREN = 1.

REGISTER 27-10: ALRMVAL (WHEN ALRMPTR<1:0> = 00): ALARM MINUTES AND SECONDS VALUE REGISTER

U-0	R/W-x	R/W-x	R/W-x	R/W-x	R/W-x	R/W-x	R/W-x
—	MINTEN2	MINTEN1	MINTEN0	MINONE3	MINONE2	MINONE1	MINONE0
bit 15							bit 8

U-0	R/W-x	R/W-x	R/W-x	R/W-x	R/W-x	R/W-x	R/W-x
—	SECTEN2	SECTEN1	SECTEN0	SECONE3	SECONE2	SECONE1	SECONE0
bit 7							bit 0

Legend:

R = Readable bit	W = Writable bit	U = Unimplemented bit, read as '0'
-n = Value at POR	'1' = Bit is set	'0' = Bit is cleared
		x = Bit is unknown

- bit 15 **Unimplemented:** Read as '0'
- bit 14-12 **MINTEN<2:0>:** Binary Coded Decimal Value of Minute's Tens Digit bits
Contains a value from 0 to 5.
- bit 11-8 **MINONE<3:0>:** Binary Coded Decimal Value of Minute's Ones Digit bits
Contains a value from 0 to 9.
- bit 7 **Unimplemented:** Read as '0'
- bit 6-4 **SECTEN<2:0>:** Binary Coded Decimal Value of Second's Tens Digit bits
Contains a value from 0 to 5.
- bit 3-0 **SECONE<3:0>:** Binary Coded Decimal Value of Second's Ones Digit bits
Contains a value from 0 to 9.

dsPIC33EPXXGM3XX/6XX/7XX

NOTES:

28.0 PARALLEL MASTER PORT (PMP)

Note 1: This data sheet summarizes the features of the dsPIC33EPXXXGM3XX/6XX/7XX family of devices. It is not intended to be a comprehensive reference source. To complement the information in this data sheet, refer to the “dsPIC33/PIC24 Family Reference Manual”, “Parallel Master Port (PMP)” (DS70576), which is available from the Microchip web site (www.microchip.com).

2: Some registers and associated bits described in this section may not be available on all devices. Refer to **Section 4.0 “Memory Organization”** in this data sheet for device-specific register and bit information.

The Parallel Master Port (PMP) module is a parallel 8-bit I/O module, specifically designed to communicate with a wide variety of parallel devices, such as communication peripherals, LCDs, external memory devices and microcontrollers. Because the interface to parallel peripherals varies significantly, the PMP is highly configurable.

Key features of the PMP module include:

- Eight Data Lines
- Up to 16 Programmable Address Lines
- Up to 2 Chip Select Lines
- Programmable Strobe Options:
 - Individual read and write strobes, or
 - Read/Write strobe with enable strobe
- Address Auto-Increment/Auto-Decrement
- Programmable Address/Data Multiplexing
- Programmable Polarity on Control Signals
- Legacy Parallel Slave Port (PSP) Support
- Enhanced Parallel Slave Support:
 - Address support
 - 4-byte deep auto-incrementing buffer
- Programmable Wait States

FIGURE 28-1: PMP MODULE PINOUT AND CONNECTIONS TO EXTERNAL DEVICES

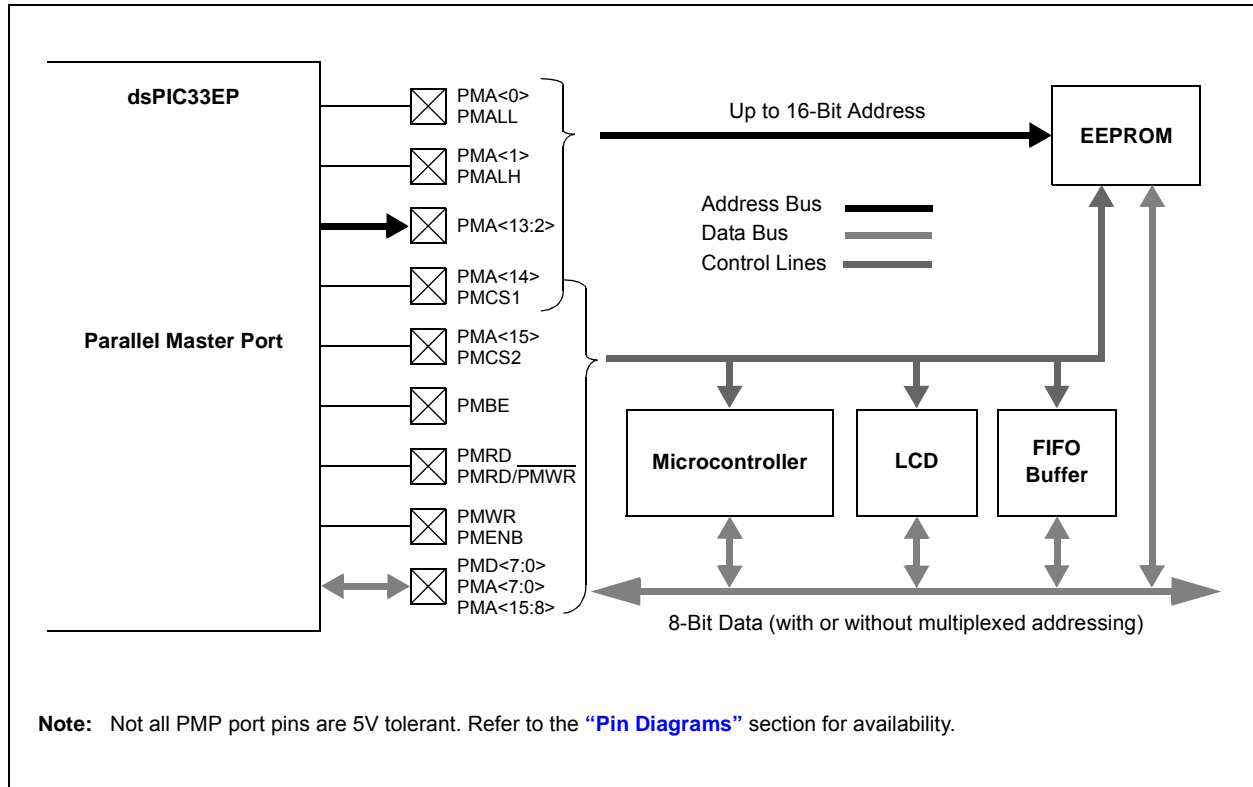

dsPIC33EPXXXGM3XX/6XX/7XX

28.1 PMP Control Registers

REGISTER 28-1: PMCON: PARALLEL MASTER PORT CONTROL REGISTER⁽³⁾

R/W-0	U-0	R/W-0	R/W-0	R/W-0	R/W-0	R/W-0	R/W-0
PMPEN	—	PSIDL	ADRMUX1	ADRMUX0	PTBEEN	PTWREN	PTRDEN
bit 15							bit 8

R/W-0	R/W-0	R/W-0 ⁽¹⁾	R/W-0 ⁽¹⁾	R/W-0 ⁽¹⁾	R/W-0	R/W-0	R/W-0
CSF1	CSF0	ALP	CS2P	CS1P	BEP	WRSP	RDSP
bit 7							bit 0

Legend:

R = Readable bit	W = Writable bit	U = Unimplemented bit, read as '0'
-n = Value at Reset	'1' = Bit is set	'0' = Bit is cleared
		x = Bit is unknown

- bit 15 **PMPEN:** Parallel Master Port Enable bit
 1 = PMP module is enabled
 0 = PMP module is disabled, no off-chip access is performed
- bit 14 **Unimplemented:** Read as '0'
- bit 13 **PSIDL:** PMP Stop in Idle Mode bit
 1 = Discontinues module operation when device enters Idle mode
 0 = Continues module operation in Idle mode
- bit 12-11 **ADRMUX<1:0>:** Address/Data Multiplexing Selection bits
 11 = Reserved
 10 = All 16 bits of address are multiplexed on PMD<7:0> pins
 01 = Lower eight bits of address are multiplexed on PMD<7:0> pins, upper eight bits are on PMA<15:8>
 00 = Address and data appear on separate pins
- bit 10 **PTBEEN:** Byte Enable Port Enable bit (16-Bit Master mode)
 1 = PMBE port is enabled
 0 = PMBE port is disabled
- bit 9 **PTWREN:** Write Enable Strobe Port Enable bit
 1 = PMWR/PMENB port is enabled
 0 = PMWR/PMENB port is disabled
- bit 8 **PTRDEN:** Read/Write Strobe Port Enable bit
 1 = PMRD/ $\overline{\text{PMWR}}$ port is enabled
 0 = PMRD/ $\overline{\text{PMWR}}$ port is disabled
- bit 7-6 **CSF<1:0>:** Chip Select Function bits
 11 = Reserved
 10 = PMCS1 and PMCS2 function as Chip Select
 01 = PMCS2 functions as Chip Select, PMCS1 functions as Address Bit 14
 00 = PMCS1 and PMCS2 function as Address Bits 15 and 14
- bit 5 **ALP:** Address Latch Polarity bit⁽¹⁾
 1 = Active-high (PMALL and PMALH)
 0 = Active-low (PMALL and PMALH)
- bit 4 **CS2P:** Chip Select 1 Polarity bit⁽¹⁾
 1 = Active-high (PMCS2)
 0 = Active-low (PMCS2)

- Note 1:** These bits have no effect when their corresponding pins are used as address lines.
Note 2: PMCS1 applies to Master mode and PMCS applies to Slave mode.
Note 3: This register is not available on 44-pin devices.

REGISTER 28-1: PMCON: PARALLEL MASTER PORT CONTROL REGISTER⁽³⁾ (CONTINUED)

bit 3	CS1P: Chip Select 0 Polarity bit ⁽¹⁾ 1 = Active-high (PMCS1/PMCS) ⁽²⁾ 0 = Active-low (PMCS1/PMCS)
bit 2	BEP: Byte Enable Polarity bit 1 = Byte enable is active-high (PMBE) 0 = Byte enable is active-low (PMBE)
bit 1	WRSP: Write Strobe Polarity bit <u>For Slave Modes and Master Mode 2 (PMMODE<9:8> = 00, 01, 10):</u> 1 = Write strobe is active-high (PMWR) 0 = Write strobe is active-low (PMWR) <u>For Master Mode 1 (PMMODE<9:8> = 11):</u> 1 = Enables strobe active-high (PMENB) 0 = Enables strobe active-low (PMENB)
bit 0	RDSP: Read Strobe Polarity bit <u>For Slave Modes and Master Mode 2 (PMMODE<9:8> = 00, 01, 10):</u> 1 = Read strobe is active-high (PMRD) 0 = Read strobe is active-low (PMRD) <u>For Master Mode 1 (PMMODE<9:8> = 11):</u> 1 = Enables strobe active-high (PMRD/PMWR) 0 = Enables strobe active-low (PMRD/PMWR)

- Note 1:** These bits have no effect when their corresponding pins are used as address lines.
- 2:** PMCS1 applies to Master mode and PMCS applies to Slave mode.
- 3:** This register is not available on 44-pin devices.

dsPIC33EPXXXGM3XX/6XX/7XX

REGISTER 28-2: PMMODE: PARALLEL MASTER PORT MODE REGISTER⁽⁴⁾

R-0	R/W-0	R/W-0	R/W-0	R/W-0	R/W-0	R/W-0	R/W-0
BUSY	IRQM1	IRQM0	INCM1	INCM0	MODE16	MODE1	MODE0
bit 15						bit 8	

R/W-0	R/W-0	R/W-0	R/W-0	R/W-0	R/W-0	R/W-0	R/W-0
WAITB1 ^(1,2,3)	WAITB0 ^(1,2,3)	WAITM3	WAITM2	WAITM1	WAITM0	WAITE1 ^(1,2,3)	WAITE0 ^(1,2,3)
bit 7						bit 0	

Legend:

R = Readable bit W = Writable bit U = Unimplemented bit, read as '0'
 -n = Value at Reset '1' = Bit is set '0' = Bit is cleared x = Bit is unknown

- bit 15 **BUSY:** Busy bit (Master mode only)
 1 = Port is busy
 0 = Port is not busy
- bit 14-13 **IRQM<1:0>:** Interrupt Request Mode bits
 11 = Interrupt is generated when Read Buffer 3 is read or Write Buffer 3 is written (Buffered PSP mode), or on a read/write operation when PMA<1:0> = 11 (Addressable PSP mode only)
 10 = Reserved
 01 = Interrupt is generated at the end of the read/write cycle
 00 = No Interrupt is generated
- bit 12-11 **INCM<1:0>:** Increment Mode bits
 11 = PSP read and write buffers auto-increment (Legacy PSP mode only)
 10 = Decrement ADDR by 1 every read/write cycle
 01 = Increment ADDR by 1 every read/write cycle
 00 = No increment or decrement of address
- bit 10 **MODE16:** 8/16-Bit Mode bit
 1 = 16-Bit Mode: Data register is 16 bits, a read/write to the Data register invokes two 8-bit transfers
 0 = 8-Bit Mode: Data register is 8 bits, a read/write to the Data register invokes one 8-bit transfer
- bit 9-8 **MODE<1:0>:** Parallel Slave Port Mode Select bits
 11 = Master Mode 1 (PMCSx, PMRD/PMWR, PMENB, PMBE, PMA<x:0> and PMD<7:0>)
 10 = Master Mode 2 (PMCSx, PMRD, PMWR, PMBE, PMA<x:0> and PMD<7:0>)
 01 = Enhanced PSP, control signals (PMRD, PMWR, PMCSx, PMD<7:0> and PMA<1:0>)
 00 = Legacy Parallel Slave Port, control signals (PMRD, PMWR, PMCSx and PMD<7:0>)
- bit 7-6 **WAITB<1:0>:** Data Setup to Read/Write/Address Phase Wait State Configuration bits^(1,2,3)
 11 = Data Wait of 4 TP (demultiplexed/multiplexed); address phase of 4 TP (multiplexed)
 10 = Data Wait of 3 TP (demultiplexed/multiplexed); address phase of 3 TP (multiplexed)
 01 = Data Wait of 2 TP (demultiplexed/multiplexed); address phase of 2 TP (multiplexed)
 00 = Data Wait of 1 TP (demultiplexed/multiplexed); address phase of 1 TP (multiplexed)

Note 1: The applied Wait state depends on whether data and address are multiplexed or demultiplexed. See **Section 4.1.8 "Wait States"** in the **"Parallel Master Port (PMP)"** (DS70576) in the *"dsPIC33/PIC24 Family Reference Manual"* for more information.

2: WAITB<1:0> and WAITE<1:0> bits are ignored whenever WAITM<3:0> = 0000.

3: TP = 1/FP.

4: This register is not available on 44-pin devices.

REGISTER 28-2: PMMODE: PARALLEL MASTER PORT MODE REGISTER⁽⁴⁾ (CONTINUED)

bit 5-2 **WAITM<3:0>**: Read to Byte Enable Strobe Wait State Configuration bits

1111 = Wait of additional 15 TP

-
-
-

0001 = Wait of additional 1 TP

0000 = No additional Wait cycles (operation forced into one TP)

bit 1-0 **WAITE<1:0>**: Data Hold After Strobe Wait State Configuration bits^(1,2,3)

11 = Wait of 4 TP

10 = Wait of 3 TP

01 = Wait of 2 TP

00 = Wait of 1 TP

Note 1: The applied Wait state depends on whether data and address are multiplexed or demultiplexed. See **Section 4.1.8 “Wait States”** in the **“Parallel Master Port (PMP)”** (DS70576) in the *“dsPIC33/PIC24 Family Reference Manual”* for more information.

2: WAITB<1:0> and WAITE<1:0> bits are ignored whenever WAITM<3:0> = 0000.

3: TP = 1/FP.

4: This register is not available on 44-pin devices.

dsPIC33EPXXXGM3XX/6XX/7XX

REGISTER 28-3: PMADDR: PARALLEL MASTER PORT ADDRESS REGISTER (MASTER MODES ONLY)^(1,2)

R/W-0	R/W-0	R/W-0	R/W-0	R/W-0	R/W-0	R/W-0	R/W-0
CS2	CS1	ADDR13	ADDR12	ADDR11	ADDR10	ADDR9	ADDR8
bit 15						bit 8	

R/W-0	R/W-0	R/W-0	R/W-0	R/W-0	R/W-0	R/W-0	R/W-0
ADDR7	ADDR6	ADDR5	ADDR4	ADDR3	ADDR2	ADDR1	ADDR0
bit 7						bit 0	

Legend:

R = Readable bit	W = Writable bit	U = Unimplemented bit, read as '0'
-n = Value at Reset	'1' = Bit is set	'0' = Bit is cleared
		x = Bit is unknown

bit 15 **CS2:** Chip Select 2 bit
If PMCON<7:6> = 10 or 01:
 1 = Chip Select 2 is active
 0 = Chip Select 2 is inactive
If PMCON<7:6> = 11 or 00:
 Bit functions as ADDR15.

bit 14 **CS1:** Chip Select 1 bit
If PMCON<7:6> = 10:
 1 = Chip Select 1 is active
 0 = Chip Select 1 is inactive
If PMCON<7:6> = 11 or 0x:
 Bit functions as ADDR14.

bit 13-0 **ADDR<13:0>:** Destination Address bits

- Note 1:** In Enhanced Slave mode, PMADDR functions as PMDOUT1, one of the two Data Buffer registers.
Note 2: This register is not available on 44-pin devices.

REGISTER 28-4: PMAEN: PARALLEL MASTER PORT ADDRESS ENABLE REGISTER⁽¹⁾

R/W-0	R/W-0	R/W-0	R/W-0	R/W-0	R/W-0	R/W-0	R/W-0
PTEN15	PTEN14	PTEN<13:8>					
bit 15							bit 8

R/W-0	R/W-0	R/W-0	R/W-0	R/W-0	R/W-0	R/W-0	R/W-0
PTEN<7:2>						PTEN<1:0>	
bit 7							bit 0

Legend:			
R = Readable bit	W = Writable bit	U = Unimplemented bit, read as '0'	
-n = Value at Reset	'1' = Bit is set	'0' = Bit is cleared	x = Bit is unknown

- bit 15 **PTEN15:** PMCS2 Strobe Enable bit
 1 = PMA15 functions as either PMA<15> or PMCS2
 0 = PMA15 functions as port I/O
- bit 14 **PTEN14:** PMCS1 Strobe Enable bit
 1 = PMA14 functions as either PMA<14> or PMCS1
 0 = PMA14 functions as port I/O
- bit 13-2 **PTEN<13:2>:** PMP Address Port Enable bits
 1 = PMA<13:2> function as PMP address lines
 0 = PMA<13:2> function as port I/Os
- bit 1-0 **PTEN<1:0>:** PMALH/PMALL Strobe Enable bits
 1 = PMA1 and PMA0 function as either PMA<1:0> or PMALH and PMALL
 0 = PMA1 and PMA0 function as port I/Os

Note 1: This register is not available on 44-pin devices.

dsPIC33EPXXXGM3XX/6XX/7XX

REGISTER 28-5: PMSTAT: PARALLEL MASTER PORT STATUS REGISTER (SLAVE MODE ONLY)⁽¹⁾

R-0	R/W-0, HS	U-0	U-0	R-0	R-0	R-0	R-0
IBF	IBOV	—	—	IB3F	IB2F	IB1F	IB0F
bit 15							bit 8

R-1	R/W-0, HS	U-0	U-0	R-1	R-1	R-1	R-1
OBE	OBUF	—	—	OB3E	OB2E	OB1E	OB0E
bit 7							bit 0

Legend:	HS = Hardware Settable bit		
R = Readable bit	W = Writable bit	U = Unimplemented bit, read as '0'	
-n = Value at Reset	'1' = Bit is set	'0' = Bit is cleared	x = Bit is unknown

- bit 15 **IBF:** Input Buffer Full Status bit
 1 = All writable Input Buffer registers are full
 0 = Some or all of the writable Input Buffer registers are empty
- bit 14 **IBOV:** Input Buffer Overflow Status bit
 1 = A write attempt to a full Input Byte register occurred (must be cleared in software)
 0 = No overflow occurred
- bit 13-12 **Unimplemented:** Read as '0'
- bit 11-8 **IB3F:IB0F:** Input Buffer x Status Full bit
 1 = Input Buffer x contains data that has not been read (reading buffer will clear this bit)
 0 = Input Buffer x does not contain any unread data
- bit 7 **OBE:** Output Buffer Empty Status bit
 1 = All readable Output Buffer registers are empty
 0 = Some or all of the readable Output Buffer registers are full
- bit 6 **OBUF:** Output Buffer Underflow Status bit
 1 = A read occurred from an empty Output Byte register (must be cleared in software)
 0 = No underflow occurred
- bit 5-4 **Unimplemented:** Read as '0'
- bit 3-0 **OB3E:OB0E:** Output Buffer x Status Empty bit
 1 = Output Buffer x is empty (writing data to the buffer will clear this bit)
 0 = Output Buffer x contains data that has not been transmitted

Note 1: This register is not available on 44-pin devices.

REGISTER 28-6: PADCFG1: PAD CONFIGURATION CONTROL REGISTER

U-0	U-0	U-0	U-0	U-0	U-0	U-0	U-0
—	—	—	—	—	—	—	—
bit 15							bit 8

U-0	U-0	U-0	U-0	U-0	U-0	R/W-0	R/W-0
—	—	—	—	—	—	RTSECSEL	PMPTTL
bit 7							bit 0

Legend:

R = Readable bit	W = Writable bit	U = Unimplemented bit, read as '0'
-n = Value at POR	'1' = Bit is set	'0' = Bit is cleared
		x = Bit is unknown

- bit 15-2 **Unimplemented:** Read as '0'
- bit 1 Not used by the PMP module.
- bit 0 **PMPTTL:** PMP Module TTL Input Buffer Select bit
 - 1 = PMP module uses TTL input buffers
 - 0 = PMP module uses Schmitt Trigger input buffers

dsPIC33EPXXGM3XX/6XX/7XX

NOTES:

29.0 PROGRAMMABLE CYCLIC REDUNDANCY CHECK (CRC) GENERATOR

Note 1: This data sheet summarizes the features of the dsPIC33EPXXXGM3XX/6XX/7XX family of devices. It is not intended to be a comprehensive reference source. To complement the information in this data sheet, refer to the “dsPIC33/PIC24 Family Reference Manual”, “32-Bit Programmable Cyclic Redundancy Check (CRC)” (DS70346), which is available from the Microchip web site (www.microchip.com).

2: Some registers and associated bits described in this section may not be available on all devices. Refer to **Section 4.0 “Memory Organization”** in this data sheet for device-specific register and bit information.

The programmable CRC generator offers the following features:

- User-Programmable (up to 32nd order) polynomial CRC equation
- Interrupt Output
- Data FIFO

The programmable CRC generator provides a hardware-implemented method of quickly generating checksums for various networking and security applications. It offers the following features:

- User-programmable CRC polynomial equation, up to 32 bits
- Programmable shift direction (little or big-endian)
- Independent data and polynomial lengths
- Configurable interrupt output
- Data FIFO

A simplified block diagram of the CRC generator is shown in **Figure 29-1**. A simple version of the CRC shift engine is shown in **Figure 29-2**.

FIGURE 29-1: CRC BLOCK DIAGRAM

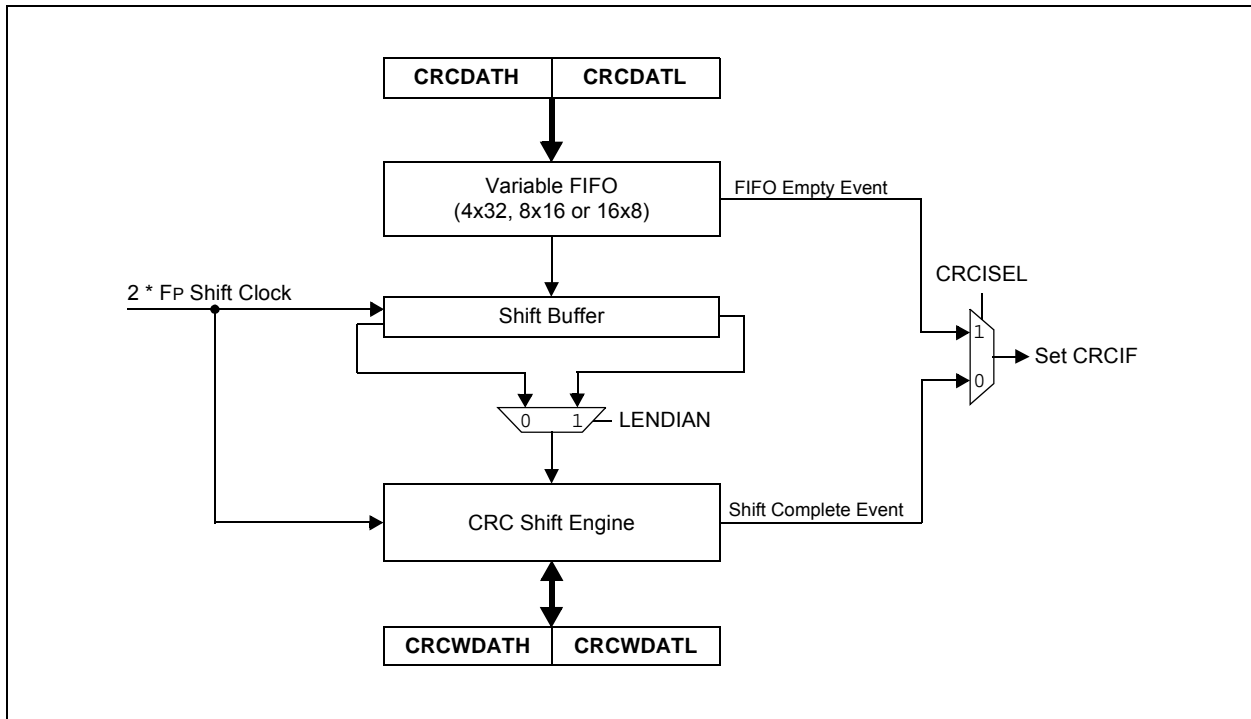
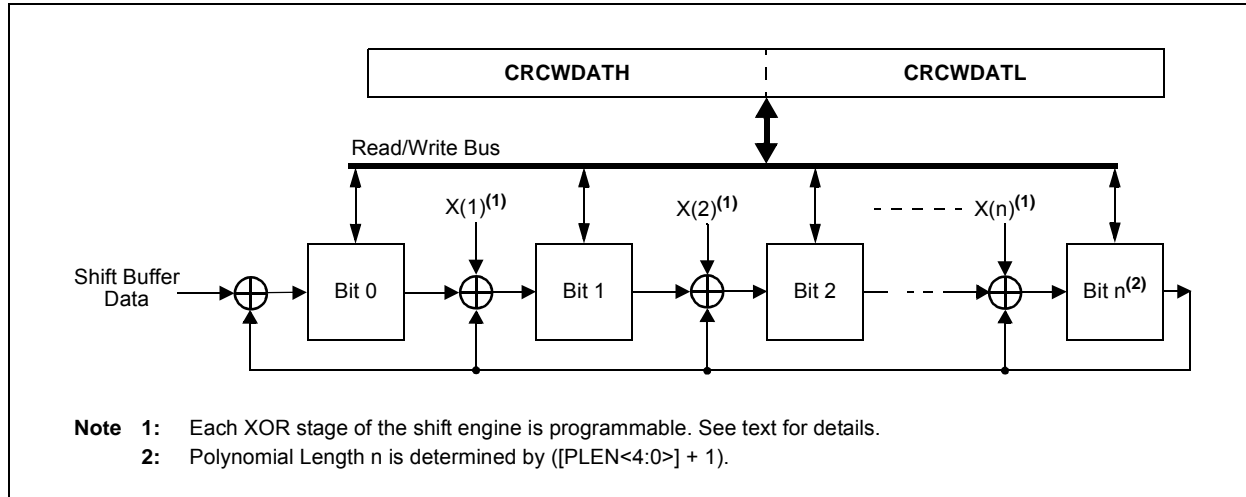

FIGURE 29-2: CRC SHIFT ENGINE DETAIL



29.1 Overview

The CRC module can be programmed for CRC polynomials of up to the 32nd order, using up to 32 bits. Polynomial length, which reflects the highest exponent in the equation, is selected by the PLEN<4:0> bits (CRCCON2<4:0>).

The CRCXORL and CRCXORH registers control which exponent terms are included in the equation. Setting a particular bit includes that exponent term in the equation; functionally, this includes an XOR operation on the corresponding bit in the CRC engine. Clearing the bit disables the XOR.

For example, consider two CRC polynomials, one a 16-bit equation and the other a 32-bit equation:

$$\begin{aligned}
 &x^{16} + x^{12} + x^5 + 1 \\
 &\text{and} \\
 &x^{32} + x^{26} + x^{23} + x^{22} + x^{16} + x^{12} + x^{11} + x^{10} + x^8 + \\
 &\quad x^7 + x^5 + x^4 + x^2 + x + 1
 \end{aligned}$$

To program these polynomials into the CRC generator, set the register bits as shown in [Table 29-1](#).

Note that the appropriate positions are set to '1' to indicate that they are used in the equation (for example, X26 and X23). The 0 bit required by the equation is always XORed; thus, X0 is a don't care. For a polynomial of length N, it is assumed that the Mth bit will always be used, regardless of the bit setting. Therefore, for a polynomial length of 32, there is no 32nd bit in the CRCxOR register.

TABLE 29-1: CRC SETUP EXAMPLES FOR 16 AND 32-BIT POLYNOMIAL

CRC Control Bits	Bit Values	
	16-Bit Polynomial	32-Bit Polynomial
PLEN<4:0>	01111	11111
X<31:16>	0000 0000 0000 000x	0000 0100 1100 0001
X<15:0>	0001 0000 0010 000x	0001 1101 1011 011x

29.2 Programmable CRC Control Registers

REGISTER 29-1: CRCCON1: CRC CONTROL REGISTER 1

R/W-0	U-0	R/W-0	R-0	R-0	R-0	R-0	R-0
CRCEN	—	CSIDL	VWORD4	VWORD3	VWORD2	VWORD1	VWORD0
bit 15							bit 8

R-0	R-1	R/W-0	R/W-0	R/W-0	U-0	U-0	U-0
CRCFUL	CRCMPT	CRCISEL	CRCGO	LENDIAN	—	—	—
bit 7							bit 0

Legend:

R = Readable bit	W = Writable bit	U = Unimplemented bit, read as '0'
-n = Value at POR	'1' = Bit is set	'0' = Bit is cleared x = Bit is unknown

- bit 15 **CRCEN:** CRC Enable bit
 1 = CRC module is enabled
 0 = CRC module is disabled; all state machines, pointers and CRCWDAT/CRCDAT are reset, other SFRs are not reset
- bit 14 **Unimplemented:** Read as '0'
- bit 13 **CSIDL:** CRC Stop in Idle Mode bit
 1 = Discontinues module operation when device enters Idle mode
 0 = Continues module operation in Idle mode
- bit 12-8 **VWORD<4:0>:** Valid Word Pointer Value bits
 Indicates the number of valid words in the FIFO; has a maximum value of 8 when PLEN<4:0> > 7 or 16 when PLEN<4:0> ≤ 7
- bit 7 **CRCFUL:** CRC FIFO Full bit
 1 = FIFO is full
 0 = FIFO is not full
- bit 6 **CRCMPT:** CRC FIFO Empty Bit
 1 = FIFO is empty
 0 = FIFO is not empty
- bit 5 **CRCISEL:** CRC Interrupt Selection bit
 1 = Interrupt on FIFO empty; final word of data is still shifting through CRC
 0 = Interrupt on shift complete and CRCWDAT results are ready
- bit 4 **CRCGO:** CRC Start bit
 1 = Start CRC serial shifter
 0 = CRC serial shifter is turned off
- bit 3 **LENDIAN:** Data Word Little-Endian Configuration bit
 1 = Data word is shifted into the CRC starting with the LSb (little endian)
 0 = Data word is shifted into the CRC starting with the MSb (big endian)
- bit 2-0 **Unimplemented:** Read as '0'

dsPIC33EPXXXGM3XX/6XX/7XX

REGISTER 29-2: CRCCON2: CRC CONTROL REGISTER 2

U-0	U-0	U-0	R/W-0	R/W-0	R/W-0	R/W-0	R/W-0	
—	—	—	DWIDTH4	DWIDTH3	DWIDTH2	DWIDTH1	DWIDTH0	
bit 15								bit 8

U-0	U-0	U-0	R/W-0	R/W-0	R/W-0	R/W-0	R/W-0	
—	—	—	PLEN4	PLEN3	PLEN2	PLEN1	PLEN0	
bit 7								bit 0

Legend:

R = Readable bit

W = Writable bit

U = Unimplemented bit, read as '0'

-n = Value at POR

'1' = Bit is set

'0' = Bit is cleared

x = Bit is unknown

bit 15-13

Unimplemented: Read as '0'

bit 12-8

DWIDTH<4:0>: Data Width Select bits

These bits set the width of the data word (DWIDTH<4:0> + 1).

bit 7-5

Unimplemented: Read as '0'

bit 4-0

PLEN<4:0>: Polynomial Length Select bits

These bits set the length of the polynomial (Polynomial Length = PLEN<4:0> + 1).

REGISTER 29-3: CRCXORH: CRC XOR POLYNOMIAL HIGH REGISTER

R/W-0	R/W-0	R/W-0	R/W-0	R/W-0	R/W-0	R/W-0	R/W-0
X<31:24>							
bit 15				bit 8			

R/W-0	R/W-0	R/W-0	R/W-0	R/W-0	R/W-0	R/W-0	R/W-0
X<23:16>							
bit 7				bit 0			

Legend:

R = Readable bit	W = Writable bit	U = Unimplemented bit, read as '0'
-n = Value at POR	'1' = Bit is set	'0' = Bit is cleared x = Bit is unknown

bit 15-0 **X<31:16>**: XOR of Polynomial Term X^n Enable bits

REGISTER 29-4: CRCXORL: CRC XOR POLYNOMIAL LOW REGISTER

R/W-0	R/W-0	R/W-0	R/W-0	R/W-0	R/W-0	R/W-0	R/W-0
X<15:8>							
bit 15				bit 8			

R/W-0	R/W-0	R/W-0	R/W-0	R/W-0	R/W-0	R/W-0	U-0
X<7:1>							—
bit 7							bit 0

Legend:

R = Readable bit	W = Writable bit	U = Unimplemented bit, read as '0'
-n = Value at POR	'1' = Bit is set	'0' = Bit is cleared x = Bit is unknown

bit 15-1 **X<15:1>**: XOR of Polynomial Term X^n Enable bits

bit 0 **Unimplemented:** Read as '0'

dsPIC33EPXXGM3XX/6XX/7XX

NOTES:

30.0 SPECIAL FEATURES

Note: This data sheet summarizes the features of the dsPIC33EPXXXGM3XX/6XX/7XX family of devices. It is not intended to be a comprehensive reference source. To complement the information in this data sheet, refer to the related section of the “dsPIC33/PIC24 Family Reference Manual”, which is available from the Microchip web site (www.microchip.com).

dsPIC33EPXXXGM3XX/6XX/7XX devices include several features intended to maximize application flexibility and reliability, and minimize cost through elimination of external components. These are:

- Flexible Configuration
- Watchdog Timer (WDT)
- Code Protection and CodeGuard™ Security
- JTAG Boundary Scan Interface
- In-Circuit Serial Programming™ (ICSP™)
- In-Circuit Emulation

30.1 Configuration Bits

In dsPIC33EPXXXGM3XX/6XX/7XX devices, the Configuration bytes are implemented as volatile memory. This means that configuration data must be programmed each time the device is powered up. Configuration data is stored at the top of the on-chip program memory space, known as the Flash Configuration bytes. Their specific locations are shown in [Table 30-1](#). The configuration data is automatically loaded from the Flash Configuration bytes to the proper Configuration Shadow registers during device Resets.

Note: Configuration data is reloaded on all types of device Resets.

When creating applications for these devices, users should always specifically allocate the location of the Flash Configuration bytes for configuration data in their code for the compiler. This is to make certain that program code is not stored in this address when the code is compiled.

The upper 2 bytes of all Flash Configuration Words in program memory should always be ‘1111 1111 1111 1111’. This makes them appear to be NOP instructions in the remote event that their locations are ever executed by accident. Since Configuration bits are not implemented in the corresponding locations, writing ‘1’s to these locations has no effect on device operation.

Note: Performing a page erase operation on the last page of program memory clears the Flash Configuration bytes, enabling code protection as a result. Therefore, users should avoid performing page erase operations on the last page of program memory.

The Configuration Flash bytes map is shown in [Table 30-1](#).

dsPIC33EPXXXGM3XX/6XX/7XX

TABLE 30-1: CONFIGURATION BYTE REGISTER MAP

File Name	Address	Device Memory Size (Kbytes)	Bits 23-8	Bit 7	Bit 6	Bit 5	Bit 4	Bit 3	Bit 2	Bit 1	Bit 0
Reserved	0157EC	128	—	—	—	—	—	—	—	—	—
	02AFEC	256									
	0557EC	512									
Reserved	0157EE	128	—	—	—	—	—	—	—	—	—
	02AFEE	256									
	0557EE	512									
FICD	0157F0	128	—	Reserved ⁽²⁾	—	JTAGEN	Reserved ⁽¹⁾	Reserved ⁽²⁾	—	ICS<1:0>	
	02AFF0	256									
	0557F0	512									
FPOR	0157F2	128	—	WDTWIN<1:0>		ALTI2C2	ALTI2C1	BOREN	—	—	—
	02AFF2	256									
	0557F2	512									
FWDT	0157F4	128	—	FWDTEN	WINDIS	PLLKEN	WDTPRE	WDTPOST<3:0>			
	02AFF4	256									
	0557F4	512									
FOSC	0157F6	128	—	FCKSM<1:0>		IOL1WAY	—	—	—	OSCI OFNC	POSCMD<1:0>
	02AFF6	256									
	0557F6	512									
FOSCSSEL	0157F8	128	—	IESO	PWMLOCK	—	—	—	FNOSC<2:0>		
	02AFF8	256									
	0557F8	512									
FGS	0157FA	128	—	—	—	—	—	—	—	GCP	GWRP
	02AFFA	256									
	0557FA	512									
Reserved	0157FC	128	—	—	—	—	—	—	—	—	—
	02AFFC	256									
	0557FC	512									
Reserved	0157FE	128	—	—	—	—	—	—	—	—	—
	02AFFE	256									
	0557FE	512									

Legend: — = unimplemented, read as '1'.

Note 1: This bit is reserved and must be programmed as '0'.

2: This bit is reserved and must be programmed as '1'.

TABLE 30-2: CONFIGURATION BITS DESCRIPTION

Bit Field	Description
GCP	General Segment Code-Protect bit 1 = User program memory is not code-protected 0 = Code protection is enabled for the entire program memory space
GWRP	General Segment Write-Protect bit 1 = User program memory is not write-protected 0 = User program memory is write-protected
IESO	Two-Speed Oscillator Start-up Enable bit ⁽¹⁾ 1 = Starts up device with FRC, then automatically switches to the user-selected oscillator source when ready 0 = Starts up device with user-selected oscillator source
PWMLOCK	PWM Lock Enable bit 1 = Certain PWM registers may only be written after a key sequence 0 = PWM registers may be written without a key sequence
FNOSC<2:0>	Oscillator Selection bits 111 = Fast RC Oscillator with Divide-by-N (FRCDIVN) 110 = Reserved 101 = Low-Power RC Oscillator (LPRC) 100 = Secondary Oscillator (SOSC) 011 = Primary Oscillator with PLL module (XT + PLL, HS + PLL, EC + PLL) 010 = Primary Oscillator (XT, HS, EC) 001 = Fast RC Oscillator with Divide-by-N with PLL module (FRCPLL) 000 = Fast RC Oscillator (FRC)
FCKSM<1:0>	Clock Switching Mode bits 1x = Clock switching is disabled, Fail-Safe Clock Monitor is disabled 01 = Clock switching is enabled, Fail-Safe Clock Monitor is disabled 00 = Clock switching is enabled, Fail-Safe Clock Monitor is enabled
IOL1WAY	Peripheral Pin Select Configuration bit 1 = Allows only one reconfiguration 0 = Allows multiple reconfigurations
OSCIOFNC	OSC2 Pin Function bit (except in XT and HS modes) 1 = OSC2 is the clock output 0 = OSC2 is the general purpose digital I/O pin
POSCMD<1:0>	Primary Oscillator Mode Select bits 11 = Primary Oscillator mode is disabled 10 = HS Crystal Oscillator mode 01 = XT Crystal Oscillator mode 00 = EC (External Clock) mode
FWDTEN	Watchdog Timer Enable bit 1 = Watchdog Timer is always enabled (LPRC oscillator cannot be disabled. Clearing the SWDTEN bit in the RCON register will have no effect.) 0 = Watchdog Timer is enabled/disabled by user software (LPRC can be disabled by clearing the SWDTEN bit in the RCON register.)
WINDIS	Watchdog Timer Window Enable bit 1 = Watchdog Timer in Non-Window mode 0 = Watchdog Timer in Window mode
PLLKEN	PLL Lock Enable bit 1 = PLL lock is enabled 0 = PLL lock is disabled

Note 1: The Two-Speed Start-up is not enabled when EC mode is used since the EC clocks will be ready immediately.

dsPIC33EPXXXGM3XX/6XX/7XX

TABLE 30-2: CONFIGURATION BITS DESCRIPTION (CONTINUED)

Bit Field	Description
WDTPRE	Watchdog Timer Prescaler bit 1 = 1:128 0 = 1:32
WDTPOST<3:0>	Watchdog Timer Postscaler bits 1111 = 1:32,768 1110 = 1:16,384 • • • 0001 = 1:2 0000 = 1:1
WDTWIN<1:0>	Watchdog Timer Window Select bits 11 = WDT Window is 25% of WDT Period 10 = WDT Window is 37.5% of WDT Period 01 = WDT Window is 50% of WDT Period 00 = WDT Window is 75% of WDT Period
ALTI2C1	Alternate I2C1 Pins bit 1 = I2C1 is mapped to the SDA1/SCL1 pins 0 = I2C1 is mapped to the ASDA1/ASCL1 pins
ALTI2C2	Alternate I2C2 Pins bit 1 = I2C2 is mapped to the SDA2/SCL2 pins 0 = I2C2 is mapped to the ASDA2/ASCL2 pins
BOREN	Brown-out Reset (BOR) Detection Enable bit 1 = BOR is enabled 0 = BOR is disabled
JTAGEN	JTAG Enable bit 1 = JTAG is enabled 0 = JTAG is disabled
ICS<1:0>	ICD Communication Channel Select bits 11 = Communicates on PGEC1 and PGED1 10 = Communicates on PGEC2 and PGED2 01 = Communicates on PGEC3 and PGED3 00 = Reserved, do not use

Note 1: The Two-Speed Start-up is not enabled when EC mode is used since the EC clocks will be ready immediately.

dsPIC33EPXXXGM3XX/6XX/7XX

30.2 User ID Words

dsPIC33EPXXXGM3XX/6XX/7XX devices contain four User ID Words, located at addresses, 0x800FF8 through 0x800FFE. The User ID Words can be used for storing product information, such as serial numbers, system manufacturing dates, manufacturing lot numbers and other application-specific information.

The User ID Words register map is shown in [Table 30-3](#).

TABLE 30-3: USER ID WORDS REGISTER MAP

File Name	Address	Bits<23:16>	Bits<15:0>
FUID0	0x800FF8	—	UID0
FUID1	0x800FFA	—	UID1
FUID2	0x800FFC	—	UID2
FUID3	0x800FFE	—	UID3

Legend: — = unimplemented, read as '1'.

30.3 On-Chip Voltage Regulator

All of the dsPIC33EPXXXGM3XX/6XX/7XX devices power their core digital logic at a nominal 1.8V. This can create a conflict for designs that are required to operate at a higher typical voltage, such as 3.3V. To simplify system design, all devices in the dsPIC33EPXXXGM3XX/6XX/7XX family incorporate an on-chip regulator that allows the device to run its core logic from VDD.

The regulator provides power to the core from the other VDD pins. A low-ESR (less than 1 Ohm) capacitor (such as tantalum or ceramic) must be connected to the VCAP pin ([Figure 30-1](#)). This helps to maintain the stability of the regulator. The recommended value for the filter capacitor is provided in [Table 33-5](#), located in [Section 33.0 “Electrical Characteristics”](#).

Note: It is important for the low-ESR capacitor to be placed as close as possible to the VCAP pin.

FIGURE 30-1: CONNECTIONS FOR THE ON-CHIP VOLTAGE REGULATOR^(1,2,3)

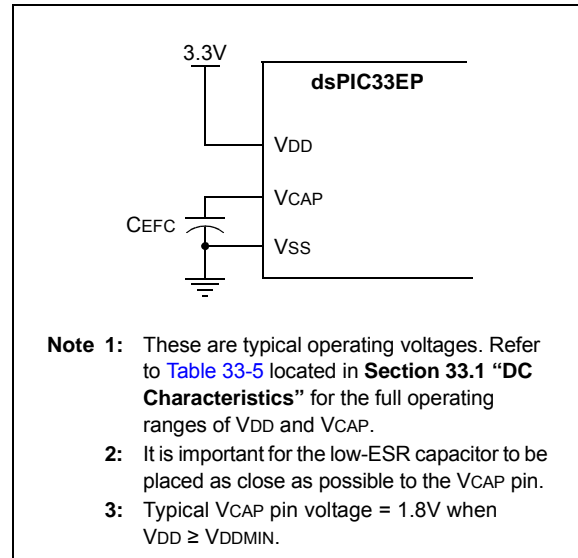

30.4 Brown-out Reset (BOR)

The Brown-out Reset (BOR) module is based on an internal voltage reference circuit that monitors the regulated supply voltage, VCAP. The main purpose of the BOR module is to generate a device Reset when a brown-out condition occurs. Brown-out conditions are generally caused by glitches on the AC mains (for example, missing portions of the AC cycle waveform due to bad power transmission lines or voltage sags due to excessive current draw when a large inductive load is turned on).

A BOR generates a Reset pulse, which resets the device. The BOR selects the clock source, based on the device Configuration bit values (FNOSC<2:0> and POSCMD<1:0>).

If an oscillator mode is selected, the BOR activates the Oscillator Start-up Timer (OST). The system clock is held until OST expires. If the PLL is used, the clock is held until the LOCK bit (OSCCON<5>) is '1'.

Concurrently, the Power-up Timer (PWRT) Time-out (TPWRT) is applied before the internal Reset is released. If TPWRT = 0 and a crystal oscillator is being used, then a nominal delay of TFSCM is applied. The total delay in this case is TFSCM. Refer to Parameter SY35 in [Table 33-21](#) of [Section 33.0 “Electrical Characteristics”](#) for specific TFSCM values.

The BOR Status bit (RCON<1>) is set to indicate that a BOR has occurred. The BOR circuit continues to operate while in Sleep or Idle mode and resets the device should VDD fall below the BOR threshold voltage.

30.5 Watchdog Timer (WDT)

For dsPIC33EPXXXGM3XX/6XX/7XX devices, the WDT is driven by the LPRC oscillator. When the WDT is enabled, the clock source is also enabled.

30.5.1 PRESCALER/POSTSCALER

The nominal WDT clock source from LPRC is 32 kHz. This feeds a prescaler that can be configured for either 5-bit (divide-by-32) or 7-bit (divide-by-128) operation. The prescaler is set by the WDTPRE Configuration bit. With a 32 kHz input, the prescaler yields a WDT time-out period (TWDT), as shown in Parameter SY12 in Table 33-21.

A variable postscaler divides down the WDT prescaler output and allows for a wide range of time-out periods. The postscaler is controlled by the WDTPOST<3:0> Configuration bits (FWDT<3:0>), which allow the selection of 16 settings, from 1:1 to 1:32,768. Using the prescaler and postscaler, time-out periods ranging from 1 ms to 131 seconds can be achieved.

The WDT, prescaler and postscaler are reset:

- On any device Reset
- On the completion of a clock switch, whether invoked by software (i.e., setting the OSWEN bit after changing the NOSC_x bits) or by hardware (i.e., Fail-Safe Clock Monitor)
- When a PWRSAV instruction is executed (i.e., Sleep or Idle mode is entered)
- When the device exits Sleep or Idle mode to resume normal operation
- By a CLRWDT instruction during normal execution

Note: The CLRWDT and PWRSAV instructions clear the prescaler and postscaler counts when executed.

30.5.2 SLEEP AND IDLE MODES

If the WDT is enabled, it continues to run during Sleep or Idle modes. When the WDT time-out occurs, the device wakes the device and code execution continues from where the PWRSAV instruction was executed. The corresponding SLEEP or IDLE bit (RCON<3,2>) needs to be cleared in software after the device wakes up.

30.5.3 ENABLING WDT

The WDT is enabled or disabled by the FWDTEN Configuration bit in the FWDT Configuration register. When the FWDTEN Configuration bit is set, the WDT is always enabled.

The WDT can be optionally controlled in software when the FWDTEN Configuration bit has been programmed to '0'. The WDT is enabled in software by setting the SWDTEN control bit (RCON<5>). The SWDTEN control bit is cleared on any device Reset. The software WDT option allows the user application to enable the WDT for critical code segments and disable the WDT during non-critical segments for maximum power savings.

The WDT flag bit, WDTO (RCON<4>), is not automatically cleared following a WDT time-out. To detect subsequent WDT events, the flag must be cleared in software.

30.5.4 WDT WINDOW

The Watchdog Timer has an optional Windowed mode enabled by programming the WINDIS bit in the WDT Configuration register (FWDT<6>). In the Windowed mode (WINDIS = 0), the WDT should be cleared based on the settings in the programmable Watchdog Timer Window select bits (WDTWIN<1:0>).

FIGURE 30-2: WDT BLOCK DIAGRAM

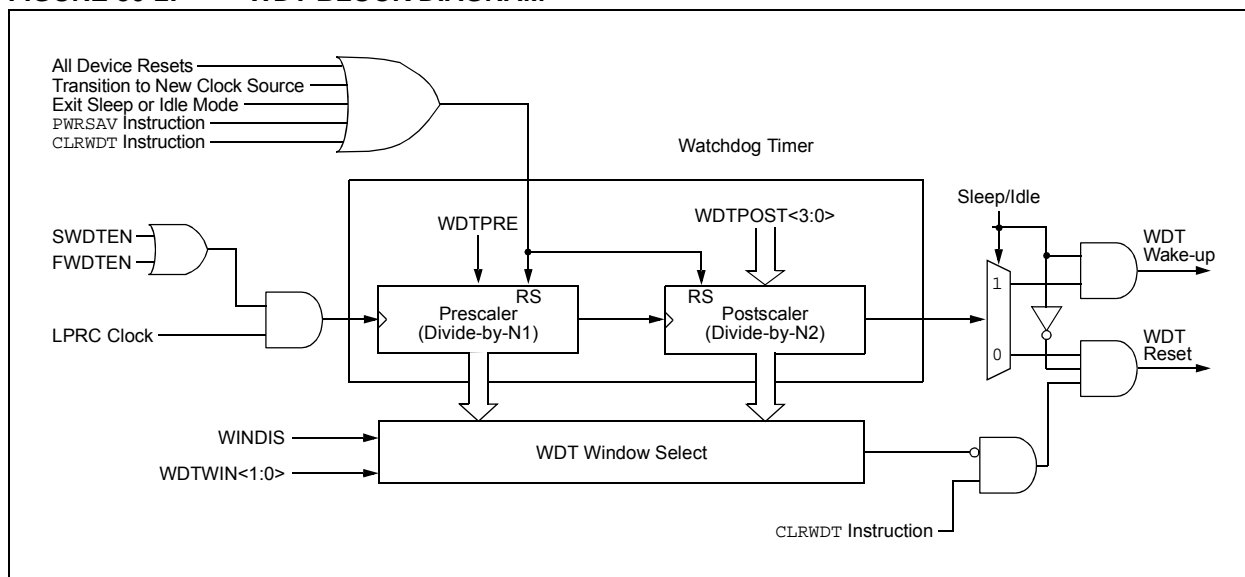

30.6 JTAG Interface

dsPIC33EPXXXGM3XX/6XX/7XX devices implement a JTAG interface, which supports boundary scan device testing. Detailed information on this interface is provided in future revisions of the document.

Note: Refer to the “dsPIC33/PIC24 Family Reference Manual”, “**Programming and Diagnostics**” (DS70608) for further information on usage, configuration and operation of the JTAG interface.

30.7 In-Circuit Serial Programming

The dsPIC33EPXXXGM3XX/6XX/7XX devices can be serially programmed while in the end application circuit. This is done with two lines for clock and data, and three other lines for power, ground and the programming sequence. Serial programming allows customers to manufacture boards with unprogrammed devices and then program the device just before shipping the product. Serial programming also allows the most recent firmware or a custom firmware to be programmed. Refer to the “dsPIC33E/PIC24E Flash Programming Specification for Devices with Volatile Configuration Bits” (DS70663) for details about In-Circuit Serial Programming (ICSP).

Any of the three pairs of programming clock/data pins can be used:

- PGEC1 and PGED1
- PGEC2 and PGED2
- PGEC3 and PGED3

30.8 In-Circuit Debugger

When MPLAB® ICD 3 or the REAL ICE™ in-circuit emulator is selected as a debugger, the in-circuit debugging functionality is enabled. This function allows simple debugging functions when used with MPLAB X IDE. Debugging functionality is controlled through the PGECx (Emulation/Debug Clock) and PGEDx (Emulation/Debug Data) pin functions.

Any of the three pairs of debugging clock/data pins can be used:

- PGEC1 and PGED1
- PGEC2 and PGED2
- PGEC3 and PGED3

To use the in-circuit debugger function of the device, the design must implement ICSP connections to MCLR, VDD, VSS and the PGECx/PGEDx pin pair. In addition, when the feature is enabled, some of the resources are not available for general use. These resources include the first 80 bytes of data RAM and two I/O pins (PGECx and PGEDx).

30.9 Code Protection and CodeGuard™ Security

The dsPIC33EPXXXGM3XX/6XX/7XX devices offer basic implementation of CodeGuard Security that supports only General Segment (GS) security. This feature helps protect individual Intellectual Property.

Note: Refer to the “dsPIC33/PIC24 Family Reference Manual”, “**CodeGuard™ Security**” (DS70634) for further information on usage, configuration and operation of CodeGuard Security.

31.0 INSTRUCTION SET SUMMARY

Note: This data sheet summarizes the features of the dsPIC33EPXXXGM3XX/6XX/7XX family of devices. It is not intended to be a comprehensive reference source. To complement the information in this data sheet, refer to the related section of the “dsPIC33/PIC24 Family Reference Manual”, which is available from the Microchip web site (www.microchip.com).

The dsPIC33EP instruction set is almost identical to that of the dsPIC30F and dsPIC33F.

Most instructions are a single program memory word (24 bits). Only three instructions require two program memory locations.

Each single-word instruction is a 24-bit word, divided into an 8-bit opcode, which specifies the instruction type and one or more operands, which further specify the operation of the instruction.

The instruction set is highly orthogonal and is grouped into five basic categories:

- Word or byte-oriented operations
- Bit-oriented operations
- Literal operations
- DSP operations
- Control operations

Table 31-1 lists the general symbols used in describing the instructions.

The dsPIC33E instruction set summary in Table 31-2 lists all the instructions, along with the status flags affected by each instruction.

Most word or byte-oriented W register instructions (including barrel shift instructions) have three operands:

- The first source operand, which is typically a register ‘Wb’ without any address modifier
- The second source operand, which is typically a register ‘Ws’ with or without an address modifier
- The destination of the result, which is typically a register ‘Wd’ with or without an address modifier

However, word or byte-oriented file register instructions have two operands:

- The file register specified by the value ‘f’
- The destination, which could be either the file register ‘f’ or the W0 register, which is denoted as ‘WREG’

Most bit-oriented instructions (including simple rotate/shift instructions) have two operands:

- The W register (with or without an address modifier) or file register (specified by the value of ‘Ws’ or ‘f’)
- The bit in the W register or file register (specified by a literal value or indirectly by the contents of register ‘Wb’)

The literal instructions that involve data movement can use some of the following operands:

- A literal value to be loaded into a W register or file register (specified by ‘k’)
- The W register or file register where the literal value is to be loaded (specified by ‘Wb’ or ‘f’)

However, literal instructions that involve arithmetic or logical operations use some of the following operands:

- The first source operand, which is a register ‘Wb’ without any address modifier
- The second source operand, which is a literal value
- The destination of the result (only if not the same as the first source operand), which is typically a register ‘Wd’ with or without an address modifier

The MAC class of DSP instructions can use some of the following operands:

- The accumulator (A or B) to be used (required operand)
- The W registers to be used as the two operands
- The X and Y address space prefetch operations
- The X and Y address space prefetch destinations
- The accumulator write back destination

The other DSP instructions do not involve any multiplication and can include:

- The accumulator to be used (required)
- The source or destination operand (designated as Wso or Wdo, respectively) with or without an address modifier
- The amount of shift specified by a W register ‘Wn’ or a literal value

The control instructions can use some of the following operands:

- A program memory address
- The mode of the Table Read and Table Write instructions

dsPIC33EPXXXGM3XX/6XX/7XX

Most instructions are a single word. Certain double-word instructions are designed to provide all the required information in these 48 bits. In the second word, the 8 MSBs are '0's. If this second word is executed as an instruction (by itself), it executes as a NOP.

The double-word instructions execute in two instruction cycles.

Most single-word instructions are executed in a single instruction cycle, unless a conditional test is true, or the Program Counter is changed as a result of the instruction, or a PSV or Table Read is performed. In these cases, the execution takes multiple instruction

cycles with the additional instruction cycle(s) executed as a NOP. Certain instructions that involve skipping over the subsequent instruction require either two or three cycles if the skip is performed, depending on whether the instruction being skipped is a single-word or two-word instruction. Moreover, double-word moves require two cycles.

Note: For more details on the instruction set, refer to the "16-bit MCU and DSC Programmer's Reference Manual" (DS70157).

TABLE 31-1: SYMBOLS USED IN OPCODE DESCRIPTIONS

Field	Description
#text	Means literal defined by "text"
(text)	Means "content of text"
[text]	Means "the location addressed by text"
{ }	Optional field or operation
a ∈ {b, c, d}	a is selected from the set of values b, c, d
<n:m>	Register bit field
.b	Byte mode selection
.d	Double-Word mode selection
.S	Shadow register select
.w	Word mode selection (default)
Acc	One of two accumulators {A, B}
AWB	Accumulator write back destination address register ∈ {W13, [W13]+ = 2}
bit4	4-bit bit selection field (used in word addressed instructions) ∈ {0...15}
C, DC, N, OV, Z	MCU Status bits: Carry, Digit Carry, Negative, Overflow, Sticky Zero
Expr	Absolute address, label or expression (resolved by the linker)
f	File register address ∈ {0x0000...0x1FFF}
lit1	1-bit unsigned literal ∈ {0,1}
lit4	4-bit unsigned literal ∈ {0...15}
lit5	5-bit unsigned literal ∈ {0...31}
lit8	8-bit unsigned literal ∈ {0...255}
lit10	10-bit unsigned literal ∈ {0...255} for Byte mode, {0:1023} for Word mode
lit14	14-bit unsigned literal ∈ {0...16384}
lit16	16-bit unsigned literal ∈ {0...65535}
lit23	23-bit unsigned literal ∈ {0...8388608}; LSb must be '0'
None	Field does not require an entry, can be blank
OA, OB, SA, SB	DSP Status bits: ACCA Overflow, ACCB Overflow, ACCA Saturate, ACCB Saturate
PC	Program Counter
Slit10	10-bit signed literal ∈ {-512...511}
Slit16	16-bit signed literal ∈ {-32768...32767}
Slit6	6-bit signed literal ∈ {-16...16}
Wb	Base W register ∈ {W0...W15}
Wd	Destination W register ∈ { Wd, [Wd], [Wd++], [Wd--], [++Wd], [--Wd] }
Wdo	Destination W register ∈ { Wnd, [Wnd], [Wnd++], [Wnd--], [++Wnd], [--Wnd], [Wnd+Wb] }
Wm, Wn	Dividend, Divisor Working register pair (direct addressing)

TABLE 31-1: SYMBOLS USED IN OPCODE DESCRIPTIONS (CONTINUED)

Field	Description
Wm*Wm	Multiplicand and Multiplier Working register pair for Square instructions $\in \{W4 * W4, W5 * W5, W6 * W6, W7 * W7\}$
Wm*Wn	Multiplicand and Multiplier Working register pair for DSP instructions $\in \{W4 * W5, W4 * W6, W4 * W7, W5 * W6, W5 * W7, W6 * W7\}$
Wn	One of 16 Working registers $\in \{W0...W15\}$
Wnd	One of 16 Destination Working registers $\in \{W0...W15\}$
Wns	One of 16 Source Working registers $\in \{W0...W15\}$
WREG	W0 (Working register used in File register instructions)
Ws	Source W register $\in \{Ws, [Ws], [Ws++] , [Ws--], [++Ws], [--Ws] \}$
Wso	Source W register $\in \{Wns, [Wns], [Wns++] , [Wns--], [++Wns], [--Wns], [Wns+Wb] \}$
Wx	X Data Space Prefetch Address register for DSP instructions $\in \{[W8] + = 6, [W8] + = 4, [W8] + = 2, [W8], [W8] - = 6, [W8] - = 4, [W8] - = 2, [W9] + = 6, [W9] + = 4, [W9] + = 2, [W9], [W9] - = 6, [W9] - = 4, [W9] - = 2, [W9 + W12], \text{none}\}$
Wxd	X Data Space Prefetch Destination register for DSP instructions $\in \{W4...W7\}$
Wy	Y Data Space Prefetch Address register for DSP instructions $\in \{[W10] + = 6, [W10] + = 4, [W10] + = 2, [W10], [W10] - = 6, [W10] - = 4, [W10] - = 2, [W11] + = 6, [W11] + = 4, [W11] + = 2, [W11], [W11] - = 6, [W11] - = 4, [W11] - = 2, [W11 + W12], \text{none}\}$
Wyd	Y Data Space Prefetch Destination register for DSP instructions $\in \{W4...W7\}$

dsPIC33EPXXXGM3XX/6XX/7XX

TABLE 31-2: INSTRUCTION SET OVERVIEW

Base Instr #	Assembly Mnemonic	Assembly Syntax	Description	# of Words	# of Cycles	Status Flags Affected
1	ADD	ADD <i>Acc</i>	Add Accumulators	1	1	OA,OB,SA,SB
		ADD <i>f</i>	$f = f + WREG$	1	1	C,DC,N,OV,Z
		ADD <i>f, WREG</i>	$WREG = f + WREG$	1	1	C,DC,N,OV,Z
		ADD <i>#lit10, Wn</i>	$Wd = lit10 + Wd$	1	1	C,DC,N,OV,Z
		ADD <i>Wb, Ws, Wd</i>	$Wd = Wb + Ws$	1	1	C,DC,N,OV,Z
		ADD <i>Wb, #lit5, Wd</i>	$Wd = Wb + lit5$	1	1	C,DC,N,OV,Z
		ADD <i>Wso, #Slit4, Acc</i>	16-bit Signed Add to Accumulator	1	1	OA,OB,SA,SB
2	ADDC	ADDC <i>f</i>	$f = f + WREG + (C)$	1	1	C,DC,N,OV,Z
		ADDC <i>f, WREG</i>	$WREG = f + WREG + (C)$	1	1	C,DC,N,OV,Z
		ADDC <i>#lit10, Wn</i>	$Wd = lit10 + Wd + (C)$	1	1	C,DC,N,OV,Z
		ADDC <i>Wb, Ws, Wd</i>	$Wd = Wb + Ws + (C)$	1	1	C,DC,N,OV,Z
		ADDC <i>Wb, #lit5, Wd</i>	$Wd = Wb + lit5 + (C)$	1	1	C,DC,N,OV,Z
3	AND	AND <i>f</i>	$f = f .AND. WREG$	1	1	N,Z
		AND <i>f, WREG</i>	$WREG = f .AND. WREG$	1	1	N,Z
		AND <i>#lit10, Wn</i>	$Wd = lit10 .AND. Wd$	1	1	N,Z
		AND <i>Wb, Ws, Wd</i>	$Wd = Wb .AND. Ws$	1	1	N,Z
		AND <i>Wb, #lit5, Wd</i>	$Wd = Wb .AND. lit5$	1	1	N,Z
4	ASR	ASR <i>f</i>	$f = \text{Arithmetic Right Shift } f$	1	1	C,N,OV,Z
		ASR <i>f, WREG</i>	$WREG = \text{Arithmetic Right Shift } f$	1	1	C,N,OV,Z
		ASR <i>Ws, Wd</i>	$Wd = \text{Arithmetic Right Shift } Ws$	1	1	C,N,OV,Z
		ASR <i>Wb, Wns, Wnd</i>	$Wnd = \text{Arithmetic Right Shift } Wb \text{ by } Wns$	1	1	N,Z
		ASR <i>Wb, #lit5, Wnd</i>	$Wnd = \text{Arithmetic Right Shift } Wb \text{ by } lit5$	1	1	N,Z
5	BCLR	BCLR <i>f, #bit4</i>	Bit Clear <i>f</i>	1	1	None
		BCLR <i>Ws, #bit4</i>	Bit Clear <i>Ws</i>	1	1	None
6	BRA	BRA <i>C, Expr</i>	Branch if Carry	1	1 (4)	None
		BRA <i>GE, Expr</i>	Branch if greater than or equal	1	1 (4)	None
		BRA <i>GEU, Expr</i>	Branch if unsigned greater than or equal	1	1 (4)	None
		BRA <i>GT, Expr</i>	Branch if greater than	1	1 (4)	None
		BRA <i>GTU, Expr</i>	Branch if unsigned greater than	1	1 (4)	None
		BRA <i>LE, Expr</i>	Branch if less than or equal	1	1 (4)	None
		BRA <i>LEU, Expr</i>	Branch if unsigned less than or equal	1	1 (4)	None
		BRA <i>LT, Expr</i>	Branch if less than	1	1 (4)	None
		BRA <i>LTU, Expr</i>	Branch if unsigned less than	1	1 (4)	None
		BRA <i>N, Expr</i>	Branch if Negative	1	1 (4)	None
		BRA <i>NC, Expr</i>	Branch if Not Carry	1	1 (4)	None
		BRA <i>NN, Expr</i>	Branch if Not Negative	1	1 (4)	None
		BRA <i>NOV, Expr</i>	Branch if Not Overflow	1	1 (4)	None
		BRA <i>NZ, Expr</i>	Branch if Not Zero	1	1 (4)	None
		BRA <i>OA, Expr</i>	Branch if Accumulator A overflow	1	1 (4)	None
		BRA <i>OB, Expr</i>	Branch if Accumulator B overflow	1	1 (4)	None
		BRA <i>OV, Expr</i>	Branch if Overflow	1	1 (4)	None
		BRA <i>SA, Expr</i>	Branch if Accumulator A saturated	1	1 (4)	None
		BRA <i>SB, Expr</i>	Branch if Accumulator B saturated	1	1 (4)	None
		BRA <i>Expr</i>	Branch Unconditionally	1	4	None
BRA <i>Z, Expr</i>	Branch if Zero	1	1 (4)	None		
BRA <i>Wn</i>	Computed Branch	1	4	None		
7	BSET	BSET <i>f, #bit4</i>	Bit Set <i>f</i>	1	1	None
		BSET <i>Ws, #bit4</i>	Bit Set <i>Ws</i>	1	1	None

Note: Read and Read-Modify-Write (e.g., bit operations and logical operations) on non-CPU SFRs incur an additional instruction cycle.

TABLE 31-2: INSTRUCTION SET OVERVIEW (CONTINUED)

Base Instr #	Assembly Mnemonic	Assembly Syntax	Description	# of Words	# of Cycles	Status Flags Affected
8	BSW	BSW.C Ws,Wb	Write C bit to Ws<Wb>	1	1	None
		BSW.Z Ws,Wb	Write Z bit to Ws<Wb>	1	1	None
9	BTG	BTG f,#bit4	Bit Toggle f	1	1	None
		BTG Ws,#bit4	Bit Toggle Ws	1	1	None
10	BTSC	BTSC f,#bit4	Bit Test f, Skip if Clear	1	1 (2 or 3)	None
		BTSC Ws,#bit4	Bit Test Ws, Skip if Clear	1	1 (2 or 3)	None
11	BTSS	BTSS f,#bit4	Bit Test f, Skip if Set	1	1 (2 or 3)	None
		BTSS Ws,#bit4	Bit Test Ws, Skip if Set	1	1 (2 or 3)	None
12	BTST	BTST f,#bit4	Bit Test f	1	1	Z
		BTST.C Ws,#bit4	Bit Test Ws to C	1	1	C
		BTST.Z Ws,#bit4	Bit Test Ws to Z	1	1	Z
		BTST.C Ws,Wb	Bit Test Ws<Wb> to C	1	1	C
		BTST.Z Ws,Wb	Bit Test Ws<Wb> to Z	1	1	Z
13	BTSTS	BTSTS f,#bit4	Bit Test then Set f	1	1	Z
		BTSTS.C Ws,#bit4	Bit Test Ws to C, then Set	1	1	C
		BTSTS.Z Ws,#bit4	Bit Test Ws to Z, then Set	1	1	Z
14	CALL	CALL lit23	Call subroutine	2	4	SFA
		CALL Wn	Call indirect subroutine	1	4	SFA
		CALL.L Wn	Call indirect subroutine (long address)	1	4	SFA
15	CLR	CLR f	f = 0x0000	1	1	None
		CLR WREG	WREG = 0x0000	1	1	None
		CLR Ws	Ws = 0x0000	1	1	None
		CLR Acc,Wx,Wxd,Wy,Wyd,AWB	Clear Accumulator	1	1	OA,OB,SA,SB
16	CLRWDT	CLRWDT	Clear Watchdog Timer	1	1	WDTO,Sleep
17	COM	COM f	f = \bar{f}	1	1	N,Z
		COM f,WREG	WREG = \bar{f}	1	1	N,Z
		COM Ws,Wd	Wd = \overline{Ws}	1	1	N,Z
18	CP	CP f	Compare f with WREG	1	1	C,DC,N,OV,Z
		CP Wb,#lit8	Compare Wb with lit8	1	1	C,DC,N,OV,Z
		CP Wb,Ws	Compare Wb with Ws (Wb – Ws)	1	1	C,DC,N,OV,Z
19	CP0	CP0 f	Compare f with 0x0000	1	1	C,DC,N,OV,Z
		CP0 Ws	Compare Ws with 0x0000	1	1	C,DC,N,OV,Z
20	CPB	CPB f	Compare f with WREG, with Borrow	1	1	C,DC,N,OV,Z
		CPB Wb,#lit8	Compare Wb with lit8, with Borrow	1	1	C,DC,N,OV,Z
		CPB Wb,Ws	Compare Wb with Ws, with Borrow (Wb – Ws – C)	1	1	C,DC,N,OV,Z
21	CPSEQ	CPSEQ Wb,Wn	Compare Wb with Wn, skip if =	1	1 (2 or 3)	None
	CPBEQ	CPBEQ Wb,Wn,Expr	Compare Wb with Wn, branch if =	1	1 (5)	None
22	CPSGT	CPSGT Wb,Wn	Compare Wb with Wn, skip if >	1	1 (2 or 3)	None
	CPBGT	CPBGT Wb,Wn,Expr	Compare Wb with Wn, branch if >	1	1 (5)	None
23	CPSLT	CPSLT Wb,Wn	Compare Wb with Wn, skip if <	1	1 (2 or 3)	None
	CPBLT	CPBLT Wb,Wn,Expr	Compare Wb with Wn, branch if <	1	1 (5)	None
24	CPSNE	CPSNE Wb,Wn	Compare Wb with Wn, skip if ≠	1	1 (2 or 3)	None
	CPBNE	CPBNE Wb,Wn,Expr	Compare Wb with Wn, branch if ≠	1	1 (5)	None

Note: Read and Read-Modify-Write (e.g., bit operations and logical operations) on non-CPU SFRs incur an additional instruction cycle.

dsPIC33EPXXXGM3XX/6XX/7XX

TABLE 31-2: INSTRUCTION SET OVERVIEW (CONTINUED)

Base Instr #	Assembly Mnemonic	Assembly Syntax	Description	# of Words	# of Cycles	Status Flags Affected
25	DAW	DAW Wn	Wn = decimal adjust Wn	1	1	C
26	DEC	DEC f	$f = f - 1$	1	1	C,DC,N,OV,Z
		DEC f, WREG	WREG = $f - 1$	1	1	C,DC,N,OV,Z
		DEC Ws, Wd	$Wd = Ws - 1$	1	1	C,DC,N,OV,Z
27	DEC2	DEC2 f	$f = f - 2$	1	1	C,DC,N,OV,Z
		DEC2 f, WREG	WREG = $f - 2$	1	1	C,DC,N,OV,Z
		DEC2 Ws, Wd	$Wd = Ws - 2$	1	1	C,DC,N,OV,Z
28	DISI	DISI #lit14	Disable Interrupts for k instruction cycles	1	1	None
29	DIV	DIV.S Wm, Wn	Signed 16/16-bit Integer Divide	1	18	N,Z,C,OV
		DIV.SD Wm, Wn	Signed 32/16-bit Integer Divide	1	18	N,Z,C,OV
		DIV.U Wm, Wn	Unsigned 16/16-bit Integer Divide	1	18	N,Z,C,OV
		DIV.UD Wm, Wn	Unsigned 32/16-bit Integer Divide	1	18	N,Z,C,OV
30	DIVF	DIVF Wm, Wn	Signed 16/16-bit Fractional Divide	1	18	N,Z,C,OV
31	DO	DO #lit15, Expr	Do code to PC + Expr, lit15 + 1 times	2	2	None
		DO Wn, Expr	Do code to PC + Expr, (Wn) + 1 times	2	2	None
32	ED	ED Wm*Wm, Acc, Wx, Wy, Wxd	Euclidean Distance (no accumulate)	1	1	OA,OB,OAB,SA,SB,SAB
33	EDAC	EDAC Wm*Wm, Acc, Wx, Wy, Wxd	Euclidean Distance	1	1	OA,OB,OAB,SA,SB,SAB
34	EXCH	EXCH Wns, Wnd	Swap Wns with Wnd	1	1	None
35	FBCL	FBCL Ws, Wnd	Find Bit Change from Left (MSb) Side	1	1	C
36	FF1L	FF1L Ws, Wnd	Find First One from Left (MSb) Side	1	1	C
37	FF1R	FF1R Ws, Wnd	Find First One from Right (LSb) Side	1	1	C
38	GOTO	GOTO Expr	Go to address	2	4	None
		GOTO Wn	Go to indirect	1	4	None
		GOTO.L Wn	Go to indirect (long address)	1	4	None
39	INC	INC f	$f = f + 1$	1	1	C,DC,N,OV,Z
		INC f, WREG	WREG = $f + 1$	1	1	C,DC,N,OV,Z
		INC Ws, Wd	$Wd = Ws + 1$	1	1	C,DC,N,OV,Z
40	INC2	INC2 f	$f = f + 2$	1	1	C,DC,N,OV,Z
		INC2 f, WREG	WREG = $f + 2$	1	1	C,DC,N,OV,Z
		INC2 Ws, Wd	$Wd = Ws + 2$	1	1	C,DC,N,OV,Z
41	IOR	IOR f	$f = f .IOR. WREG$	1	1	N,Z
		IOR f, WREG	WREG = $f .IOR. WREG$	1	1	N,Z
		IOR #lit10, Wn	$Wd = lit10 .IOR. Wd$	1	1	N,Z
		IOR Wb, Ws, Wd	$Wd = Wb .IOR. Ws$	1	1	N,Z
		IOR Wb, #lit5, Wd	$Wd = Wb .IOR. lit5$	1	1	N,Z
42	LAC	LAC Wso, #Slit4, Acc	Load Accumulator	1	1	OA,OB,OAB,SA,SB,SAB
43	LNK	LNK #lit14	Link Frame Pointer	1	1	SFA
44	LSR	LSR f	$f = \text{Logical Right Shift } f$	1	1	C,N,OV,Z
		LSR f, WREG	WREG = $\text{Logical Right Shift } f$	1	1	C,N,OV,Z
		LSR Ws, Wd	$Wd = \text{Logical Right Shift } Ws$	1	1	C,N,OV,Z
		LSR Wb, Wns, Wnd	$Wnd = \text{Logical Right Shift } Wb \text{ by } Wns$	1	1	N,Z
		LSR Wb, #lit5, Wnd	$Wnd = \text{Logical Right Shift } Wb \text{ by } lit5$	1	1	N,Z
45	MAC	MAC Wm*Wn, Acc, Wx, Wxd, Wy, Wyd, AWB	Multiply and Accumulate	1	1	OA,OB,OAB,SA,SB,SAB
		MAC Wm*Wm, Acc, Wx, Wxd, Wy, Wyd	Square and Accumulate	1	1	OA,OB,OAB,SA,SB,SAB

Note: Read and Read-Modify-Write (e.g., bit operations and logical operations) on non-CPU SFRs incur an additional instruction cycle.

TABLE 31-2: INSTRUCTION SET OVERVIEW (CONTINUED)

Base Instr #	Assembly Mnemonic	Assembly Syntax	Description	# of Words	# of Cycles	Status Flags Affected	
46	MOV	MOV f, Wn	Move f to Wn	1	1	None	
		MOV f	Move f to f	1	1	None	
		MOV f, WREG	Move f to WREG	1	1	None	
		MOV #lit16, Wn	Move 16-bit literal to Wn	1	1	None	
		MOV.b #lit8, Wn	Move 8-bit literal to Wn	1	1	None	
		MOV Wn, f	Move Wn to f	1	1	None	
		MOV Wso, Wdo	Move Ws to Wd	1	1	None	
		MOV WREG, f	Move WREG to f	1	1	None	
		MOV.D Wns, Wd	Move Double from W(ns):W(ns + 1) to Wd	1	2	None	
		MOV.D Ws, Wnd	Move Double from Ws to W(nd + 1):W(nd)	1	2	None	
47	MOVPAG	MOVPAG #lit10, DSRPAG	Move 10-bit literal to DSRPAG	1	1	None	
		MOVPAG #lit9, DSWPAG	Move 9-bit literal to DSWPAG	1	1	None	
		MOVPAG #lit8, TBLPAG	Move 8-bit literal to TBLPAG	1	1	None	
		MOVPAGW Ws, DSRPAG	Move Ws<9:0> to DSRPAG	1	1	None	
		MOVPAGW Ws, DSWPAG	Move Ws<8:0> to DSWPAG	1	1	None	
		MOVPAGW Ws, TBLPAG	Move Ws<7:0> to TBLPAG	1	1	None	
48	MOVSAC	MOVSAC Acc, Wx, Wxd, Wy, Wyd, AWB	Prefetch and store accumulator	1	1	None	
49	MPY	MPY Wm*Wn, Acc, Wx, Wxd, Wy, Wyd	Multiply Wm by Wn to Accumulator	1	1	OA,OB,OAB,SA,SB,SAB	
		MPY Wm*Wm, Acc, Wx, Wxd, Wy, Wyd	Square Wm to Accumulator	1	1	OA,OB,OAB,SA,SB,SAB	
50	MPY.N	MPY.N Wm*Wn, Acc, Wx, Wxd, Wy, Wyd	-(Multiply Wm by Wn) to Accumulator	1	1	None	
51	MSC	MSC Wm*Wm, Acc, Wx, Wxd, Wy, Wyd, AWB	Multiply and Subtract from Accumulator	1	1	OA,OB,OAB,SA,SB,SAB	
52	MUL	MUL.SS Wb, Ws, Wnd	{Wnd + 1, Wnd} = signed(Wb) * signed(Ws)	1	1	None	
		MUL.SS Wb, Ws, Acc	Accumulator = signed(Wb) * signed(Ws)	1	1	None	
		MUL.SU Wb, Ws, Wnd	{Wnd + 1, Wnd} = signed(Wb) * unsigned(Ws)	1	1	None	
		MUL.SU Wb, Ws, Acc	Accumulator = signed(Wb) * unsigned(Ws)	1	1	None	
		MUL.SU Wb, #lit5, Acc	Accumulator = signed(Wb) * unsigned(lit5)	1	1	None	
		MUL.US Wb, Ws, Wnd	{Wnd + 1, Wnd} = unsigned(Wb) * signed(Ws)	1	1	None	
		MUL.US Wb, Ws, Acc	Accumulator = unsigned(Wb) * signed(Ws)	1	1	None	
		MUL.UU Wb, Ws, Wnd	{Wnd + 1, Wnd} = unsigned(Wb) * unsigned(Ws)	1	1	None	
		MUL.UU Wb, #lit5, Acc	Accumulator = unsigned(Wb) * unsigned(lit5)	1	1	None	
		MUL.UU Wb, Ws, Acc	Accumulator = unsigned(Wb) * unsigned(Ws)	1	1	None	
		MULW.SS Wb, Ws, Wnd	Wnd = signed(Wb) * signed(Ws)	1	1	None	
		MULW.SU Wb, Ws, Wnd	Wnd = signed(Wb) * unsigned(Ws)	1	1	None	
		MULW.US Wb, Ws, Wnd	Wnd = unsigned(Wb) * signed(Ws)	1	1	None	
		MULW.UU Wb, Ws, Wnd	Wnd = unsigned(Wb) * unsigned(Ws)	1	1	None	
		MUL.SU Wb, #lit5, Wnd	{Wnd + 1, Wnd} = signed(Wb) * unsigned(lit5)	1	1	None	
		MUL.SU Wb, #lit5, Wnd	Wnd = signed(Wb) * unsigned(lit5)	1	1	None	
		MUL.UU Wb, #lit5, Wnd	{Wnd + 1, Wnd} = unsigned(Wb) * unsigned(lit5)	1	1	None	
		MUL.UU Wb, #lit5, Wnd	Wnd = unsigned(Wb) * unsigned(lit5)	1	1	None	
		MUL	f	W3:W2 = f * WREG	1	1	None

Note: Read and Read-Modify-Write (e.g., bit operations and logical operations) on non-CPU SFRs incur an additional instruction cycle.

dsPIC33EPXXXGM3XX/6XX/7XX

TABLE 31-2: INSTRUCTION SET OVERVIEW (CONTINUED)

Base Instr #	Assembly Mnemonic	Assembly Syntax	Description	# of Words	# of Cycles	Status Flags Affected
53	NEG	NEG Acc	Negate Accumulator	1	1	OA,OB,OAB,SA,SB,SAB
		NEG f	$f = \bar{f} + 1$	1	1	C,DC,N,OV,Z
		NEG f, WREG	$WREG = \bar{f} + 1$	1	1	C,DC,N,OV,Z
		NEG Ws, Wd	$Wd = \overline{Ws} + 1$	1	1	C,DC,N,OV,Z
54	NOP	NOP	No Operation	1	1	None
		NOPR	No Operation	1	1	None
55	POP	POP f	Pop f from Top-of-Stack (TOS)	1	1	None
		POP Wdo	Pop from Top-of-Stack (TOS) to Wdo	1	1	None
		POP.D Wnd	Pop from Top-of-Stack (TOS) to W(nd):W(nd + 1)	1	2	None
		POP.S	Pop Shadow Registers	1	1	All
56	PUSH	PUSH f	Push f to Top-of-Stack (TOS)	1	1	None
		PUSH Wso	Push Wso to Top-of-Stack (TOS)	1	1	None
		PUSH.D Wns	Push W(ns):W(ns + 1) to Top-of-Stack (TOS)	1	2	None
		PUSH.S	Push Shadow Registers	1	1	None
57	PWRSVAV	PWRSVAV #lit1	Go into Sleep or Idle mode	1	1	WDT0,Sleep
58	RCALL	RCALL Expr	Relative Call	1	4	SFA
		RCALL Wn	Computed Call	1	4	SFA
59	REPEAT	REPEAT #lit15	Repeat Next Instruction lit15 + 1 times	1	1	None
		REPEAT Wn	Repeat Next Instruction (Wn) + 1 times	1	1	None
60	RESET	RESET	Software device Reset	1	1	None
61	RETFIE	RETFIE	Return from interrupt	1	6 (5)	SFA
62	RETLW	RETLW #lit10, Wn	Return with literal in Wn	1	6 (5)	SFA
63	RETURN	RETURN	Return from Subroutine	1	6 (5)	SFA
64	RLC	RLC f	f = Rotate Left through Carry f	1	1	C,N,Z
		RLC f, WREG	WREG = Rotate Left through Carry f	1	1	C,N,Z
		RLC Ws, Wd	Wd = Rotate Left through Carry Ws	1	1	C,N,Z
65	RLNC	RLNC f	f = Rotate Left (No Carry) f	1	1	N,Z
		RLNC f, WREG	WREG = Rotate Left (No Carry) f	1	1	N,Z
		RLNC Ws, Wd	Wd = Rotate Left (No Carry) Ws	1	1	N,Z
66	RRC	RRC f	f = Rotate Right through Carry f	1	1	C,N,Z
		RRC f, WREG	WREG = Rotate Right through Carry f	1	1	C,N,Z
		RRC Ws, Wd	Wd = Rotate Right through Carry Ws	1	1	C,N,Z
67	RRNC	RRNC f	f = Rotate Right (No Carry) f	1	1	N,Z
		RRNC f, WREG	WREG = Rotate Right (No Carry) f	1	1	N,Z
		RRNC Ws, Wd	Wd = Rotate Right (No Carry) Ws	1	1	N,Z
68	SAC	SAC Acc, #Slit4, Wdo	Store Accumulator	1	1	None
		SAC.R Acc, #Slit4, Wdo	Store Rounded Accumulator	1	1	None
69	SE	SE Ws, Wnd	Wnd = sign-extended Ws	1	1	C,N,Z
70	SETM	SETM f	f = 0xFFFF	1	1	None
		SETM WREG	WREG = 0xFFFF	1	1	None
		SETM Ws	Ws = 0xFFFF	1	1	None
71	SFTAC	SFTAC Acc, Wn	Arithmetic Shift Accumulator by (Wn)	1	1	OA,OB,OAB,SA,SB,SAB
		SFTAC Acc, #Slit6	Arithmetic Shift Accumulator by Slit6	1	1	OA,OB,OAB,SA,SB,SAB

Note: Read and Read-Modify-Write (e.g., bit operations and logical operations) on non-CPU SFRs incur an additional instruction cycle.

TABLE 31-2: INSTRUCTION SET OVERVIEW (CONTINUED)

Base Instr #	Assembly Mnemonic	Assembly Syntax	Description	# of Words	# of Cycles	Status Flags Affected
72	SL	SL f	f = Left Shift f	1	1	C,N,OV,Z
		SL f, WREG	WREG = Left Shift f	1	1	C,N,OV,Z
		SL Ws, Wd	Wd = Left Shift Ws	1	1	C,N,OV,Z
		SL Wb, Wns, Wnd	Wnd = Left Shift Wb by Wns	1	1	N,Z
		SL Wb, #lit5, Wnd	Wnd = Left Shift Wb by lit5	1	1	N,Z
73	SUB	SUB Acc	Subtract Accumulators	1	1	OA,OB,OAB,SA,SB,SAB
		SUB f	f = f - WREG	1	1	C,DC,N,OV,Z
		SUB f, WREG	WREG = f - WREG	1	1	C,DC,N,OV,Z
		SUB #lit10, Wn	Wn = Wn - lit10	1	1	C,DC,N,OV,Z
		SUB Wb, Ws, Wd	Wd = Wb - Ws	1	1	C,DC,N,OV,Z
		SUB Wb, #lit5, Wd	Wd = Wb - lit5	1	1	C,DC,N,OV,Z
74	SUBB	SUBB f	f = f - WREG - (\bar{C})	1	1	C,DC,N,OV,Z
		SUBB f, WREG	WREG = f - WREG - (\bar{C})	1	1	C,DC,N,OV,Z
		SUBB #lit10, Wn	Wn = Wn - lit10 - (\bar{C})	1	1	C,DC,N,OV,Z
		SUBB Wb, Ws, Wd	Wd = Wb - Ws - (\bar{C})	1	1	C,DC,N,OV,Z
		SUBB Wb, #lit5, Wd	Wd = Wb - lit5 - (\bar{C})	1	1	C,DC,N,OV,Z
75	SUBR	SUBR f	f = WREG - f	1	1	C,DC,N,OV,Z
		SUBR f, WREG	WREG = WREG - f	1	1	C,DC,N,OV,Z
		SUBR Wb, Ws, Wd	Wd = Ws - Wb	1	1	C,DC,N,OV,Z
		SUBR Wb, #lit5, Wd	Wd = lit5 - Wb	1	1	C,DC,N,OV,Z
76	SUBBR	SUBBR f	f = WREG - f - (\bar{C})	1	1	C,DC,N,OV,Z
		SUBBR f, WREG	WREG = WREG - f - (\bar{C})	1	1	C,DC,N,OV,Z
		SUBBR Wb, Ws, Wd	Wd = Ws - Wb - (\bar{C})	1	1	C,DC,N,OV,Z
		SUBBR Wb, #lit5, Wd	Wd = lit5 - Wb - (\bar{C})	1	1	C,DC,N,OV,Z
77	SWAP	SWAP.b Wn	Wn = nibble swap Wn	1	1	None
		SWAP Wn	Wn = byte swap Wn	1	1	None
78	TBLRDH	TBLRDH Ws, Wd	Read Prog<23:16> to Wd<7:0>	1	5	None
79	TBLRDL	TBLRDL Ws, Wd	Read Prog<15:0> to Wd	1	5	None
80	TBLWTH	TBLWTH Ws, Wd	Write Ws<7:0> to Prog<23:16>	1	2	None
81	TBLWTL	TBLWTL Ws, Wd	Write Ws to Prog<15:0>	1	2	None
82	ULNK	ULNK	Unlink Frame Pointer	1	1	SFA
83	XOR	XOR f	f = f .XOR. WREG	1	1	N,Z
		XOR f, WREG	WREG = f .XOR. WREG	1	1	N,Z
		XOR #lit10, Wn	Wd = lit10 .XOR. Wd	1	1	N,Z
		XOR Wb, Ws, Wd	Wd = Wb .XOR. Ws	1	1	N,Z
		XOR Wb, #lit5, Wd	Wd = Wb .XOR. lit5	1	1	N,Z
84	ZE	ZE Ws, Wnd	Wnd = Zero-extend Ws	1	1	C,Z,N

Note: Read and Read-Modify-Write (e.g., bit operations and logical operations) on non-CPU SFRs incur an additional instruction cycle.

dsPIC33EPXXGM3XX/6XX/7XX

NOTES:

32.0 DEVELOPMENT SUPPORT

The PIC[®] microcontrollers (MCU) and dsPIC[®] digital signal controllers (DSC) are supported with a full range of software and hardware development tools:

- Integrated Development Environment
 - MPLAB[®] X IDE Software
- Compilers/Assemblers/Linkers
 - MPLAB XC Compiler
 - MPASM[™] Assembler
 - MPLINK[™] Object Linker/
MPLIB[™] Object Librarian
 - MPLAB Assembler/Linker/Librarian for
Various Device Families
- Simulators
 - MPLAB X SIM Software Simulator
- Emulators
 - MPLAB REAL ICE[™] In-Circuit Emulator
- In-Circuit Debuggers/Programmers
 - MPLAB ICD 3
 - PICKit[™] 3
- Device Programmers
 - MPLAB PM3 Device Programmer
- Low-Cost Demonstration/Development Boards,
Evaluation Kits and Starter Kits
- Third-party development tools

32.1 MPLAB X Integrated Development Environment Software

The MPLAB X IDE is a single, unified graphical user interface for Microchip and third-party software, and hardware development tool that runs on Windows[®], Linux and Mac OS[®] X. Based on the NetBeans IDE, MPLAB X IDE is an entirely new IDE with a host of free software components and plug-ins for high-performance application development and debugging. Moving between tools and upgrading from software simulators to hardware debugging and programming tools is simple with the seamless user interface.

With complete project management, visual call graphs, a configurable watch window and a feature-rich editor that includes code completion and context menus, MPLAB X IDE is flexible and friendly enough for new users. With the ability to support multiple tools on multiple projects with simultaneous debugging, MPLAB X IDE is also suitable for the needs of experienced users.

Feature-Rich Editor:

- Color syntax highlighting
- Smart code completion makes suggestions and provides hints as you type
- Automatic code formatting based on user-defined rules
- Live parsing

User-Friendly, Customizable Interface:

- Fully customizable interface: toolbars, toolbar buttons, windows, window placement, etc.
- Call graph window

Project-Based Workspaces:

- Multiple projects
- Multiple tools
- Multiple configurations
- Simultaneous debugging sessions

File History and Bug Tracking:

- Local file history feature
- Built-in support for Bugzilla issue tracker

32.2 MPLAB XC Compilers

The MPLAB XC Compilers are complete ANSI C compilers for all of Microchip's 8, 16 and 32-bit MCU and DSC devices. These compilers provide powerful integration capabilities, superior code optimization and ease of use. MPLAB XC Compilers run on Windows, Linux or MAC OS X.

For easy source level debugging, the compilers provide debug information that is optimized to the MPLAB X IDE.

The free MPLAB XC Compiler editions support all devices and commands, with no time or memory restrictions, and offer sufficient code optimization for most applications.

MPLAB XC Compilers include an assembler, linker and utilities. The assembler generates relocatable object files that can then be archived or linked with other relocatable object files and archives to create an executable file. MPLAB XC Compiler uses the assembler to produce its object file. Notable features of the assembler include:

- Support for the entire device instruction set
- Support for fixed-point and floating-point data
- Command-line interface
- Rich directive set
- Flexible macro language
- MPLAB X IDE compatibility

32.3 MPASM Assembler

The MPASM Assembler is a full-featured, universal macro assembler for PIC10/12/16/18 MCUs.

The MPASM Assembler generates relocatable object files for the MPLINK Object Linker, Intel® standard HEX files, MAP files to detail memory usage and symbol reference, absolute LST files that contain source lines and generated machine code, and COFF files for debugging.

The MPASM Assembler features include:

- Integration into MPLAB X IDE projects
- User-defined macros to streamline assembly code
- Conditional assembly for multipurpose source files
- Directives that allow complete control over the assembly process

32.4 MPLINK Object Linker/ MPLIB Object Librarian

The MPLINK Object Linker combines relocatable objects created by the MPASM Assembler. It can link relocatable objects from precompiled libraries, using directives from a linker script.

The MPLIB Object Librarian manages the creation and modification of library files of precompiled code. When a routine from a library is called from a source file, only the modules that contain that routine will be linked in with the application. This allows large libraries to be used efficiently in many different applications.

The object linker/library features include:

- Efficient linking of single libraries instead of many smaller files
- Enhanced code maintainability by grouping related modules together
- Flexible creation of libraries with easy module listing, replacement, deletion and extraction

32.5 MPLAB Assembler, Linker and Librarian for Various Device Families

MPLAB Assembler produces relocatable machine code from symbolic assembly language for PIC24, PIC32 and dsPIC DSC devices. MPLAB XC Compiler uses the assembler to produce its object file. The assembler generates relocatable object files that can then be archived or linked with other relocatable object files and archives to create an executable file. Notable features of the assembler include:

- Support for the entire device instruction set
- Support for fixed-point and floating-point data
- Command-line interface
- Rich directive set
- Flexible macro language
- MPLAB X IDE compatibility

32.6 MPLAB X SIM Software Simulator

The MPLAB X SIM Software Simulator allows code development in a PC-hosted environment by simulating the PIC MCUs and dsPIC DSCs on an instruction level. On any given instruction, the data areas can be examined or modified and stimuli can be applied from a comprehensive stimulus controller. Registers can be logged to files for further run-time analysis. The trace buffer and logic analyzer display extend the power of the simulator to record and track program execution, actions on I/O, most peripherals and internal registers.

The MPLAB X SIM Software Simulator fully supports symbolic debugging using the MPLAB XC Compilers, and the MPASM and MPLAB Assemblers. The software simulator offers the flexibility to develop and debug code outside of the hardware laboratory environment, making it an excellent, economical software development tool.

32.7 MPLAB REAL ICE In-Circuit Emulator System

The MPLAB REAL ICE In-Circuit Emulator System is Microchip's next generation high-speed emulator for Microchip Flash DSC and MCU devices. It debugs and programs all 8, 16 and 32-bit MCU, and DSC devices with the easy-to-use, powerful graphical user interface of the MPLAB X IDE.

The emulator is connected to the design engineer's PC using a high-speed USB 2.0 interface and is connected to the target with either a connector compatible with in-circuit debugger systems (RJ-11) or with the new high-speed, noise tolerant, Low-Voltage Differential Signal (LVDS) interconnection (CAT5).

The emulator is field upgradable through future firmware downloads in MPLAB X IDE. MPLAB REAL ICE offers significant advantages over competitive emulators including full-speed emulation, run-time variable watches, trace analysis, complex breakpoints, logic probes, a ruggedized probe interface and long (up to three meters) interconnection cables.

32.8 MPLAB ICD 3 In-Circuit Debugger System

The MPLAB ICD 3 In-Circuit Debugger System is Microchip's most cost-effective, high-speed hardware debugger/programmer for Microchip Flash DSC and MCU devices. It debugs and programs PIC Flash microcontrollers and dsPIC DSCs with the powerful, yet easy-to-use graphical user interface of the MPLAB IDE.

The MPLAB ICD 3 In-Circuit Debugger probe is connected to the design engineer's PC using a high-speed USB 2.0 interface and is connected to the target with a connector compatible with the MPLAB ICD 2 or MPLAB REAL ICE systems (RJ-11). MPLAB ICD 3 supports all MPLAB ICD 2 headers.

32.9 PICkit 3 In-Circuit Debugger/Programmer

The MPLAB PICkit 3 allows debugging and programming of PIC and dsPIC Flash microcontrollers at a most affordable price point using the powerful graphical user interface of the MPLAB IDE. The MPLAB PICkit 3 is connected to the design engineer's PC using a full-speed USB interface and can be connected to the target via a Microchip debug (RJ-11) connector (compatible with MPLAB ICD 3 and MPLAB REAL ICE). The connector uses two device I/O pins and the Reset line to implement in-circuit debugging and In-Circuit Serial Programming™ (ICSP™).

32.10 MPLAB PM3 Device Programmer

The MPLAB PM3 Device Programmer is a universal, CE compliant device programmer with programmable voltage verification at VDDMIN and VDDMAX for maximum reliability. It features a large LCD display (128 x 64) for menus and error messages, and a modular, detachable socket assembly to support various package types. The ICSP cable assembly is included as a standard item. In Stand-Alone mode, the MPLAB PM3 Device Programmer can read, verify and program PIC devices without a PC connection. It can also set code protection in this mode. The MPLAB PM3 connects to the host PC via an RS-232 or USB cable. The MPLAB PM3 has high-speed communications and optimized algorithms for quick programming of large memory devices, and incorporates an MMC card for file storage and data applications.

32.11 Demonstration/Development Boards, Evaluation Kits and Starter Kits

A wide variety of demonstration, development and evaluation boards for various PIC MCUs and dsPIC DSCs allows quick application development on fully functional systems. Most boards include prototyping areas for adding custom circuitry and provide application firmware and source code for examination and modification.

The boards support a variety of features, including LEDs, temperature sensors, switches, speakers, RS-232 interfaces, LCD displays, potentiometers and additional EEPROM memory.

The demonstration and development boards can be used in teaching environments, for prototyping custom circuits and for learning about various microcontroller applications.

In addition to the PICDEM™ and dsPICDEM™ demonstration/development board series of circuits, Microchip has a line of evaluation kits and demonstration software for analog filter design, KEELOQ® security ICs, CAN, IrDA®, PowerSmart battery management, SEEVAL® evaluation system, Sigma-Delta ADC, flow rate sensing, plus many more.

Also available are starter kits that contain everything needed to experience the specified device. This usually includes a single application and debug capability, all on one board.

Check the Microchip web page (www.microchip.com) for the complete list of demonstration, development and evaluation kits.

32.12 Third-Party Development Tools

Microchip also offers a great collection of tools from third-party vendors. These tools are carefully selected to offer good value and unique functionality.

- Device Programmers and Gang Programmers from companies, such as SoftLog and CCS
- Software Tools from companies, such as Gimpel and Trace Systems
- Protocol Analyzers from companies, such as Saleae and Total Phase
- Demonstration Boards from companies, such as MikroElektronika, Digilent® and Olimex
- Embedded Ethernet Solutions from companies, such as EZ Web Lynx, WIZnet and IPLogika®

33.0 ELECTRICAL CHARACTERISTICS

This section provides an overview of dsPIC33EPXXXGM3XX/6XX/7XX electrical characteristics. Additional information will be provided in future revisions of this document as it becomes available.

Absolute maximum ratings for the dsPIC33EPXXXGM3XX/6XX/7XX family are listed below. Exposure to these maximum rating conditions for extended periods may affect device reliability. Functional operation of the device at those or any other conditions above the parameters indicated in the operation listings of this specification is not implied.

Absolute Maximum Ratings

(See Note 1)

Ambient temperature under bias	-40°C to +125°C
Storage temperature	-65°C to +160°C
Voltage on VDD with respect to VSS	-0.3V to +4.0V
Voltage on any pin that is not 5V tolerant with respect to VSS ⁽³⁾	-0.3V to (VDD + 0.3V)
Voltage on any 5V tolerant pin with respect to VSS when VDD ≥ 3.0V ⁽³⁾	-0.3V to +5.5V
Voltage on any 5V tolerant pin with respect to VSS when VDD < 3.0V ⁽³⁾	-0.3V to +3.6V
Voltage on VCAP with respect to VSS	1.62V to 1.98V
Maximum current out of VSS pin	350 mA
Maximum current into VDD pin ⁽²⁾	350 mA
Maximum current sunk by any I/O pin	20 mA
Maximum current sourced by I/O pin	18 mA
Maximum current sourced/sunk by all ports ^(2,4)	200 mA

Note 1: Stresses above those listed under “Absolute Maximum Ratings” may cause permanent damage to the device. This is a stress rating only and functional operation of the device at those or any other conditions above those indicated in the operational listings of this specification is not implied. Exposure to maximum rating conditions for extended periods may affect device reliability.

2: Maximum allowable current is a function of device maximum power dissipation (see [Table 33-2](#)).

3: See the “[Pin Diagrams](#)” section for the 5V tolerant pins.

4: Exceptions are: RA3, RA4, RA7, RA9, RA10, RB7-RB15, RC3, RC15, RD1-RD4, which are able to sink 30 mA and source 20 mA.

dsPIC33EPXXXGM3XX/6XX/7XX

33.1 DC Characteristics

TABLE 33-1: OPERATING MIPS vs. VOLTAGE

Characteristic	VDD Range (in Volts)	Temperature Range (in °C)	Maximum MIPS
			dsPIC33EPXXXGM3XX/6XX/7XX
I-Temp	3.0V to 3.6V ⁽¹⁾	-40°C to +85°C	70
E-Temp	3.0V to 3.6V ⁽¹⁾	-40°C to +125°C	60

Note 1: Device is functional at $V_{BORMIN} < V_{DD} < V_{DDMIN}$. Analog modules: ADC, op amp/comparator and comparator voltage reference will have degraded performance. Device functionality is tested but not characterized. Refer to Parameter [BO10](#) in [Table 33-12](#) for the minimum and maximum BOR values.

TABLE 33-2: THERMAL OPERATING CONDITIONS

Rating	Symbol	Min.	Typ.	Max.	Unit
Industrial Temperature Devices:					
Operating Junction Temperature Range	TJ	-40	—	+125	°C
Operating Ambient Temperature Range	TA	-40	—	+85	°C
Extended Temperature Devices:					
Operating Junction Temperature Range	TJ	-40	—	+140	°C
Operating Ambient Temperature Range	TA	-40	—	+125	°C
Power Dissipation: Internal Chip Power Dissipation: $P_{INT} = V_{DD} \times (I_{DD} - \Sigma I_{OH})$ I/O Pin Power Dissipation: $I/O = \Sigma (\{V_{DD} - V_{OH}\} \times I_{OH}) + \Sigma (V_{OL} \times I_{OL})$	PD	P _{INT} + P _{I/O}			W
Maximum Allowed Power Dissipation	PD _{MAX}	$(T_J - T_A)/\theta_{JA}$			W

TABLE 33-3: THERMAL PACKAGING CHARACTERISTICS

Characteristic	Symbol	Typ.	Max.	Unit	Notes
Package Thermal Resistance, 121-Pin BGA	θ_{JA}	40	—	°C/W	1
Package Thermal Resistance, 100-Pin TQFP 12x12 mm	θ_{JA}	43	—	°C/W	1
Package Thermal Resistance, 100-Pin TQFP 14x14 mm	θ_{JA}	—	—	°C/W	1
Package Thermal Resistance, 64-Pin QFN	θ_{JA}	28.0	—	°C/W	1
Package Thermal Resistance, 64-Pin TQFP 10x10 mm	θ_{JA}	48.3	—	°C/W	1
Package Thermal Resistance, 44-Pin QFN	θ_{JA}	29.0	—	°C/W	1
Package Thermal Resistance, 44-Pin TQFP 10x10 mm	θ_{JA}	49.8	—	°C/W	1
Package Thermal Resistance, 44-Pin VTLA 6x6 mm	θ_{JA}	25.2	—	°C/W	1
Package Thermal Resistance, 36-Pin VTLA 5x5 mm	θ_{JA}	28.5	—	°C/W	1
Package Thermal Resistance, 28-Pin QFN-S	θ_{JA}	30.0	—	°C/W	1
Package Thermal Resistance, 28-Pin SSOP	θ_{JA}	71.0	—	°C/W	1
Package Thermal Resistance, 28-Pin SOIC	θ_{JA}	69.7	—	°C/W	1
Package Thermal Resistance, 28-Pin SPDIP	θ_{JA}	60.0	—	°C/W	1

Note 1: Junction to ambient thermal resistance, Theta-JA (θ_{JA}) numbers are achieved by package simulations.

TABLE 33-4: DC TEMPERATURE AND VOLTAGE SPECIFICATIONS

DC CHARACTERISTICS			Standard Operating Conditions (see Note 3): 3.0V to 3.6V (unless otherwise stated) Operating temperature -40°C ≤ TA ≤ +85°C for Industrial -40°C ≤ TA ≤ +125°C for Extended				
Param No.	Symbol	Characteristic	Min.	Typ. ⁽¹⁾	Max.	Units	Conditions
Operating Voltage							
DC10	VDD	Supply Voltage⁽³⁾	3.0	—	3.6	V	
DC12	VDR	RAM Data Retention Voltage⁽²⁾	1.95	—	—	V	
DC16	VPOR	VDD Start Voltage to Ensure Internal Power-on Reset Signal	—	—	VSS	V	
DC17	SVDD	VDD Rise Rate to Ensure Internal Power-on Reset Signal	0.03	—	—	V/ms	0V-3.0V in 3 ms
DC18	VCORE	VDD Core⁽³⁾ Internal Regulator Voltage	1.62	1.8	1.98	V	Voltage is dependent on load, temperature and VDD

- Note 1:** Data in “Typical” column is at 3.3V, +25°C unless otherwise stated.
2: This is the limit to which VDD may be lowered without losing RAM data.
3: Device is functional at VBORMIN < VDD < VDDMIN. Analog modules: ADC, op amp/comparator and comparator voltage reference will have degraded performance. Device functionality is tested but not characterized. Refer to Parameter **BO10** in [Table 33-12](#) for the minimum and maximum BOR values.

TABLE 33-5: FILTER CAPACITOR (CEFC) SPECIFICATIONS

			Standard Operating Conditions (unless otherwise stated): Operating temperature -40°C ≤ TA ≤ +85°C for Industrial -40°C ≤ TA ≤ +125°C for Extended				
Param No.	Symbol	Characteristics	Min.	Typ.	Max.	Units	Comments
	CEFC	External Filter Capacitor Value ⁽¹⁾	4.7	10	—	μF	Capacitor must have a low series resistance (< 1 Ohm)

- Note 1:** Typical VCAP voltage = 1.8 volts when VDD ≥ VDDMIN.

dsPIC33EPXXXGM3XX/6XX/7XX

TABLE 33-6: DC CHARACTERISTICS: OPERATING CURRENT (IDD)

DC CHARACTERISTICS			Standard Operating Conditions: 3.0V to 3.6V (unless otherwise stated) Operating temperature $-40^{\circ}\text{C} \leq T_A \leq +85^{\circ}\text{C}$ for Industrial $-40^{\circ}\text{C} \leq T_A \leq +125^{\circ}\text{C}$ for Extended		
Param.	Typ. ⁽²⁾	Max.	Units	Conditions	
Operating Current (IDD)⁽¹⁾					
DC20d	6.0	18.0	mA	-40°C	3.3V 10 MIPS
DC20a	6.0	18.0	mA	+25°C	
DC20b	6.0	18.0	mA	+85°C	
DC20c	6.0	18.0	mA	+125°C	
DC21d	11.0	20.0	mA	-40°C	3.3V 20 MIPS
DC21a	11.0	20.0	mA	+25°C	
DC21b	11.0	20.0	mA	+85°C	
DC21c	11.0	20.0	mA	+125°C	
DC22d	17.0	30.0	mA	-40°C	3.3V 40 MIPS
DC22a	17.0	30.0	mA	+25°C	
DC22b	17.0	30.0	mA	+85°C	
DC22c	17.0	30.0	mA	+125°C	
DC23d	25.0	50.0	mA	-40°C	3.3V 60 MIPS
DC23a	25.0	50.0	mA	+25°C	
DC23b	25.0	50.0	mA	+85°C	
DC23c	25.0	50.0	mA	+125°C	
DC24d	30.0	60.0	mA	-40°C	3.3V 70 MIPS
DC24a	30.0	60.0	mA	+25°C	
DC24b	30.0	60.0	mA	+85°C	

Note 1: IDD is primarily a function of the operating voltage and frequency. Other factors, such as I/O pin loading and switching rate, oscillator type, internal code execution pattern and temperature, also have an impact on the current consumption. The test conditions for all IDD measurements are as follows:

- Oscillator is configured in EC mode and external clock is active, OSC1 is driven with external square wave from rail-to-rail (EC clock overshoot/undershoot < 250 mV required)
- CLKO is configured as an I/O input pin in the Configuration Word
- All I/O pins are configured as outputs and driving low
- $\overline{\text{MCLR}} = V_{\text{DD}}$, WDT and FSCM are disabled
- CPU, SRAM, program memory and data memory are operational
- No peripheral modules are operating or being clocked (defined PMDx bits are all ones)
- CPU executing

```
while(1)
{
NOP();
}
```
- JTAG is disabled

2: Data in "Typ" column is at 3.3V, +25°C unless otherwise stated.

TABLE 33-7: DC CHARACTERISTICS: IDLE CURRENT (IDLE)

DC CHARACTERISTICS			Standard Operating Conditions: 3.0V to 3.6V (unless otherwise stated) Operating temperature -40°C ≤ TA ≤ +85°C for Industrial -40°C ≤ TA ≤ +125°C for Extended			
Parameter No.	Typ.(2)	Max.	Units	Conditions		
Idle Current (IDLE)⁽¹⁾						
DC40d	1.5	8.0	mA	-40°C	3.3V	10 MIPS
DC40a	1.5	8.0	mA	+25°C		
DC40b	1.5	8.0	mA	+85°C		
DC40c	1.5	8.0	mA	+125°C		
DC41d	2.0	12.0	mA	-40°C	3.3V	20 MIPS
DC41a	2.0	12.0	mA	+25°C		
DC41b	2.0	12.0	mA	+85°C		
DC41c	2.0	12.0	mA	+125°C		
DC42d	5.5	15.0	mA	-40°C	3.3V	40 MIPS
DC42a	5.5	15.0	mA	+25°C		
DC42b	5.5	15.0	mA	+85°C		
DC42c	5.5	15.0	mA	+125°C		
DC43d	9.0	20.0	mA	-40°C	3.3V	60 MIPS
DC43a	9.0	20.0	mA	+25°C		
DC43b	9.0	20.0	mA	+85°C		
DC43c	9.0	20.0	mA	+125°C		
DC44d	10.0	25.0	mA	-40°C	3.3V	70 MIPS
DC44a	10.0	25.0	mA	+25°C		
DC44b	10.0	25.0	mA	+85°C		

Note 1: Base Idle current (IDLE) is measured as follows:

- CPU core is off, oscillator is configured in EC mode and external clock is active, OSC1 is driven with external square wave from rail-to-rail (EC clock overshoot/undershoot < 250 mV required)
- CLKO is configured as an I/O input pin in the Configuration Word
- All I/O pins are configured as outputs and driving low
- MCLR = VDD, WDT and FSCM are disabled
- No peripheral modules are operating or being clocked (defined PMDx bits are all ones)
- The NVMSIDL bit (NVMCON<12>) = 1 (i.e., Flash regulator is set to standby while the device is in Idle mode)
- The VREGSF bit (RCON<11>) = 0 (i.e., Flash regulator is set to standby while the device is in Sleep mode)
- JTAG is disabled

2: Data in the "Typical" column is at 3.3V, +25°C unless otherwise specified.

dsPIC33EPXXXGM3XX/6XX/7XX

TABLE 33-8: DC CHARACTERISTICS: POWER-DOWN CURRENT (IPD)

DC CHARACTERISTICS			Standard Operating Conditions: 3.0V to 3.6V (unless otherwise stated) Operating temperature -40°C ≤ TA ≤ +85°C for Industrial -40°C ≤ TA ≤ +125°C for Extended		
Parameter No.	Typ. ⁽²⁾	Max.	Units	Conditions	
Power-Down Current (IPD) ⁽¹⁾					
DC60d	35	100	μA	-40°C	3.3V Base Power-Down Current
DC60c	40	200	μA	+25°C	
DC60b	250	500	μA	+85°C	
DC60c	1000	2500	μA	+125°C	
DC61d	8	10	μA	-40°C	3.3V Watchdog Timer Current: ΔI _{WDT} ⁽³⁾
DC61c	10	15	μA	+25°C	
DC61b	12	20	μA	+85°C	
DC61c	13	25	μA	+125°C	

Note 1: IPD (Sleep) current is measured as follows:

- CPU core is off, oscillator is configured in EC mode and external clock is active, OSC1 is driven with external square wave from rail-to-rail (EC clock overshoot/undershoot < 250 mV required)
- CLKO is configured as an I/O input pin in the Configuration Word
- All I/O pins are configured as outputs and driving low
- $\overline{MCLR} = V_{DD}$, WDT and FSCM are disabled
- All peripheral modules are disabled (PMDx bits are all ones)
- The VREGS bit (RCON<8>) = 0 (i.e., core regulator is set to standby while the device is in Sleep mode)
- The VREGSF bit (RCON<11>) = 0 (i.e., Flash regulator is set to standby while the device is in Sleep mode)
- JTAG is disabled

2: Data in the “Typical” column is at 3.3V, +25°C unless otherwise specified.

3: The Δ current is the additional current consumed when the module is enabled. This current should be added to the base IPD current.

TABLE 33-9: DC CHARACTERISTICS: DOZE CURRENT (IDOZE)

DC CHARACTERISTICS			Standard Operating Conditions: 3.0V to 3.6V (unless otherwise stated) Operating temperature -40°C ≤ TA ≤ +85°C for Industrial -40°C ≤ TA ≤ +125°C for Extended				
Parameter No.	Typ. ⁽²⁾	Max.	Doze Ratio	Units	Conditions		
Doze Current (IDOZE)⁽¹⁾							
DC73a	20	53	1:2	mA	-40°C	3.3V	70 MIPS
DC73g	8	30	1:128	mA			
DC70a	19	53	1:2	mA	+25°C	3.3V	60 MIPS
DC70g	8	30	1:128	mA			
DC71a	20	53	1:2	mA	+85°C	3.3V	60 MIPS
DC71g	10	30	1:128	mA			
DC72a	25	42	1:2	mA	+125°C	3.3V	50 MIPS
DC72g	12	30	1:128	mA			

Note 1: IDOZE is primarily a function of the operating voltage and frequency. Other factors, such as I/O pin loading and switching rate, oscillator type, internal code execution pattern and temperature, also have an impact on the current consumption. The test conditions for all IDOZE measurements are as follows:

- Oscillator is configured in EC mode and external clock is active, OSC1 is driven with external square wave from rail-to-rail (EC clock overshoot/undershoot < 250 mV required)
- CLKO is configured as an I/O input pin in the Configuration Word
- All I/O pins are configured as outputs and driving low
- $\overline{MCLR} = V_{DD}$, WDT and FSCM are disabled
- CPU, SRAM, program memory and data memory are operational
- No peripheral modules are operating or being clocked (defined PMDx bits are all ones)
- CPU executing

```
while(1)
{
NOP();
}
```
- JTAG is disabled

2: Data in the “Typical” column is at 3.3V, +25°C unless otherwise specified.

dsPIC33EPXXXGM3XX/6XX/7XX

TABLE 33-10: DC CHARACTERISTICS: I/O PIN INPUT SPECIFICATIONS

DC CHARACTERISTICS			Standard Operating Conditions: 3.0V to 3.6V (unless otherwise stated) Operating temperature $-40^{\circ}\text{C} \leq T_A \leq +85^{\circ}\text{C}$ for Industrial $-40^{\circ}\text{C} \leq T_A \leq +125^{\circ}\text{C}$ for Extended				
Param No.	Symbol	Characteristic	Min.	Typ.	Max.	Units	Conditions
DI10 DI18 DI19	V _{IL}	Input Low Voltage					
		Any I/O Pin and $\overline{\text{MCLR}}$	V _{SS}	—	0.2 V _{DD}	V	
		I/O Pins with SDAx, SCLx	V _{SS}	—	0.3 V _{DD}	V	SMBus disabled
		I/O Pins with SDAx, SCLx	V _{SS}	—	0.8	V	SMBus enabled
DI20	V _{IH}	Input High Voltage					
		I/O Pins Not 5V Tolerant	0.8 V _{DD}	—	V _{DD}	V	(Note 3)
		I/O Pins 5V Tolerant and $\overline{\text{MCLR}}$	0.8 V _{DD}	—	5.5	V	(Note 3)
		I/O Pins with SDAx, SCLx	0.8 V _{DD}	—	5.5	V	SMBus disabled
		I/O Pins with SDAx, SCLx	2.1	—	5.5	V	SMBus enabled
DI30	ICNPU	Change Notification Pull-up Current	150	250	550	μA	V _{DD} = 3.3V, V _{PIN} = V _{SS}
DI31	ICNPD	Change Notification Pull-Down Current⁽⁴⁾	20	50	100	μA	V _{DD} = 3.3V, V _{PIN} = V _{DD}

Note 1: The leakage current on the $\overline{\text{MCLR}}$ pin is strongly dependent on the applied voltage level. The specified levels represent normal operating conditions. Higher leakage current can be measured at different input voltages.

2: Negative current is defined as current sourced by the pin.

3: See the “[Pin Diagrams](#)” section for the 5V tolerant I/O pins.

4: V_{IL} source < (V_{SS} – 0.3). Characterized but not tested.

5: Non-5V tolerant pins V_{IH} source > (V_{DD} + 0.3), 5V tolerant pins V_{IH} source > 5.5V. Characterized but not tested.

6: Digital 5V tolerant pins cannot tolerate any “positive” input injection current from input sources > 5.5V.

7: Non-zero injection currents can affect the ADC results by approximately 4-6 counts.

8: Any number and/or combination of I/O pins not excluded under I_{ICL} or I_{ICH} conditions are permitted provided the mathematical “absolute instantaneous” sum of the input injection currents from all pins do not exceed the specified limit. Characterized but not tested.

TABLE 33-10: DC CHARACTERISTICS: I/O PIN INPUT SPECIFICATIONS (CONTINUED)

DC CHARACTERISTICS			Standard Operating Conditions: 3.0V to 3.6V (unless otherwise stated) Operating temperature $-40^{\circ}\text{C} \leq T_A \leq +85^{\circ}\text{C}$ for Industrial $-40^{\circ}\text{C} \leq T_A \leq +125^{\circ}\text{C}$ for Extended				
Param No.	Symbol	Characteristic	Min.	Typ.	Max.	Units	Conditions
DI50	IIL	Input Leakage Current^(1,2) I/O Pins 5V Tolerant ⁽³⁾	-1	—	+1	μA	$V_{SS} \leq V_{PIN} \leq 5V$, Pin at high-impedance
DI51		I/O Pins Not 5V Tolerant ⁽³⁾	-1	—	+1	μA	$V_{SS} \leq V_{PIN} \leq V_{DD}$, Pin at high-impedance, $-40^{\circ}\text{C} \leq T_A \leq +85^{\circ}\text{C}$
DI51a		I/O Pins Not 5V Tolerant ⁽³⁾	-1	—	+1	μA	Analog pins shared with external reference pins, $-40^{\circ}\text{C} \leq T_A \leq +85^{\circ}\text{C}$
DI51b		I/O Pins Not 5V Tolerant ⁽³⁾	-1	—	+1	μA	$V_{SS} \leq V_{PIN} \leq V_{DD}$, Pin at high-impedance, $-40^{\circ}\text{C} \leq T_A \leq +125^{\circ}\text{C}$
DI51c		I/O Pins Not 5V Tolerant ⁽³⁾	-1	—	+1	μA	Analog pins shared with external reference pins, $-40^{\circ}\text{C} \leq T_A \leq +125^{\circ}\text{C}$
DI55		MCLR	-5	—	+5	μA	$V_{SS} \leq V_{PIN} \leq V_{DD}$
DI56		OSC1	-5	—	+5	μA	$V_{SS} \leq V_{PIN} \leq V_{DD}$, XT and HS modes

- Note 1:** The leakage current on the MCLR pin is strongly dependent on the applied voltage level. The specified levels represent normal operating conditions. Higher leakage current can be measured at different input voltages.
- 2:** Negative current is defined as current sourced by the pin.
- 3:** See the “[Pin Diagrams](#)” section for the 5V tolerant I/O pins.
- 4:** V_{IL} source $< (V_{SS} - 0.3)$. Characterized but not tested.
- 5:** Non-5V tolerant pins V_{IH} source $> (V_{DD} + 0.3)$, 5V tolerant pins V_{IH} source $> 5.5V$. Characterized but not tested.
- 6:** Digital 5V tolerant pins cannot tolerate any “positive” input injection current from input sources $> 5.5V$.
- 7:** Non-zero injection currents can affect the ADC results by approximately 4-6 counts.
- 8:** Any number and/or combination of I/O pins not excluded under IICL or IICH conditions are permitted provided the mathematical “absolute instantaneous” sum of the input injection currents from all pins do not exceed the specified limit. Characterized but not tested.

dsPIC33EPXXXGM3XX/6XX/7XX

TABLE 33-10: DC CHARACTERISTICS: I/O PIN INPUT SPECIFICATIONS (CONTINUED)

DC CHARACTERISTICS			Standard Operating Conditions: 3.0V to 3.6V (unless otherwise stated) Operating temperature $-40^{\circ}\text{C} \leq T_A \leq +85^{\circ}\text{C}$ for Industrial $-40^{\circ}\text{C} \leq T_A \leq +125^{\circ}\text{C}$ for Extended				
Param No.	Symbol	Characteristic	Min.	Typ.	Max.	Units	Conditions
DI60a	I _{ICL}	Input Low Injection Current	0	—	-5 ^(4,7)	mA	All pins except V _{DD} , V _{SS} , AV _{DD} , AV _{SS} , MCLR, V _{CAP} and RB7
DI60b	I _{ICH}	Input High Injection Current	0	—	+5 ^(5,6,7)	mA	All pins except V _{DD} , V _{SS} , AV _{DD} , AV _{SS} , MCLR, V _{CAP} , RB7 and all 5V tolerant pins ⁽⁶⁾
DI60c	ΣI_{ICT}	Total Input Injection Current (sum of all I/O and control pins)	-20 ⁽⁸⁾	—	+20 ⁽⁸⁾	mA	Absolute instantaneous sum of all \pm input injection currents from all I/O pins: ($ I_{ICL} + I_{ICH} $) $\leq \Sigma I_{ICT}$

- Note 1:** The leakage current on the MCLR pin is strongly dependent on the applied voltage level. The specified levels represent normal operating conditions. Higher leakage current can be measured at different input voltages.
- 2:** Negative current is defined as current sourced by the pin.
- 3:** See the “[Pin Diagrams](#)” section for the 5V tolerant I/O pins.
- 4:** V_{IL} source < (V_{SS} – 0.3). Characterized but not tested.
- 5:** Non-5V tolerant pins V_{IH} source > (V_{DD} + 0.3), 5V tolerant pins V_{IH} source > 5.5V. Characterized but not tested.
- 6:** Digital 5V tolerant pins cannot tolerate any “positive” input injection current from input sources > 5.5V.
- 7:** Non-zero injection currents can affect the ADC results by approximately 4-6 counts.
- 8:** Any number and/or combination of I/O pins not excluded under I_{ICL} or I_{ICH} conditions are permitted provided the mathematical “absolute instantaneous” sum of the input injection currents from all pins do not exceed the specified limit. Characterized but not tested.

TABLE 33-11: DC CHARACTERISTICS: I/O PIN OUTPUT SPECIFICATIONS

DC CHARACTERISTICS			Standard Operating Conditions: 3.0V to 3.6V (unless otherwise stated) Operating temperature -40°C ≤ TA ≤ +85°C for Industrial -40°C ≤ TA ≤ +125°C for Extended				
Param.	Symbol	Characteristic	Min.	Typ.	Max.	Units	Conditions
DO10	VOL	Output Low Voltage 4x Sink Driver Pins ⁽¹⁾	—	—	0.4	V	VDD = 3.3V, IOL ≤ 6 mA, -40°C ≤ TA ≤ +85°C, IOL ≤ 5 mA, +85°C < TA ≤ +125°C
		Output Low Voltage 8x Sink Driver Pins ⁽²⁾	—	—	0.4	V	VDD = 3.3V, IOL ≤ 12 mA, -40°C ≤ TA ≤ +85°C, IOL ≤ 8 mA, +85°C < TA ≤ +125°C
DO20	VOH	Output High Voltage 4x Source Driver Pins ⁽¹⁾	2.4	—	—	V	IOH ≥ -10 mA, VDD = 3.3V
		Output High Voltage 8x Source Driver Pins ⁽²⁾	2.4	—	—	V	IOH ≥ -15 mA, VDD = 3.3V
DO20A	VOH1	Output High Voltage 4x Source Driver Pins ⁽¹⁾	1.5	—	—	V	IOH ≥ -14 mA, VDD = 3.3V
			2.0	—	—		IOH ≥ -12 mA, VDD = 3.3V
			3.0	—	—		IOH ≥ -7 mA, VDD = 3.3V
		Output High Voltage 8x Source Driver Pins ⁽²⁾	1.5	—	—	V	IOH ≥ -22 mA, VDD = 3.3V
			2.0	—	—		IOH ≥ -18 mA, VDD = 3.3V
			3.0	—	—		IOH ≥ -10 mA, VDD = 3.3V

Note 1: Includes all I/O pins that are not 8x Sink Driver pins (see below).

2: Includes the following pins:

For 44-pin devices: RA3, RA4, RA7, RA9, RA10, RB7, RB<15:9>, RC1 and RC<9:3>

For 64-pin devices: RA4, RA7, RA<10:9>, RB7, RB<15:9>, RC1, RC<9:3>, RC15 and RG<8:7>

For 100-pin devices: RA4, RA7, RA9, RA10, RB7, RB<15:9>, RC1, RC<9:3>, RC15, RD<3:1> and RG<8:6>

TABLE 33-12: ELECTRICAL CHARACTERISTICS: BOR

DC CHARACTERISTICS			Standard Operating Conditions: 3.0V to 3.6V (unless otherwise stated) Operating temperature -40°C ≤ TA ≤ +85°C for Industrial -40°C ≤ TA ≤ +125°C for Extended				
Param No.	Symbol	Characteristic	Min. ⁽¹⁾	Typ.	Max.	Units	Conditions
BO10	VBOR	BOR Event on VDD Transition High-to-Low	2.7	—	2.95	V	VDD (Note 2, Note 3)
PO10	VPOR	POR Event on VDD Transition High-to-Low	1.75	—	1.95	V	(Note 2)

Note 1: Parameters are for design guidance only and are not tested in manufacturing.

2: The VBOR specification is relative to VDD.

3: The device is functional at VBORMIN < VDD < VDDMIN. Analog modules: ADC, op amp/comparator and comparator voltage reference will have degraded performance. Device functionality is tested but not characterized.

dsPIC33EPXXXGM3XX/6XX/7XX

TABLE 33-13: DC CHARACTERISTICS: PROGRAM MEMORY

DC CHARACTERISTICS			Standard Operating Conditions: V_{BOR} (min)V to 3.6V (unless otherwise stated) Operating temperature $-40^{\circ}\text{C} \leq T_A \leq +85^{\circ}\text{C}$ for Industrial $-40^{\circ}\text{C} \leq T_A \leq +125^{\circ}\text{C}$ for Extended				
Param No.	Symbol	Characteristic	Min	Typ ⁽¹⁾	Max	Units	Conditions
Program Flash Memory							
D130	EP	Cell Endurance	10,000	—	—	E/W	-40°C to $+125^{\circ}\text{C}$
D131	VPR	VDD for Read	V_{BORMIN}	—	3.6	V	
D132b	VPEW	VDD for Self-Timed Write	3.0	—	3.6	V	
D134	TRETD	Characteristic Retention	20	—	—	Year	Provided no other specifications are violated, -40°C to $+125^{\circ}\text{C}$
D135	IDDP	Supply Current During Programming	—	10	—	mA	
D138a	TWW	Word Write Cycle Time	46.5	46.9	47.4	μs	TWW = 346 FRC cycles, $T_A = +85^{\circ}\text{C}$ (Note 2)
D138b	TWW	Word Write Cycle Time	46.0	—	47.9	μs	TWW = 346 FRC cycles, $T_A = +125^{\circ}\text{C}$ (Note 2)
D136a	TPE	Row Write Time	0.667	0.673	0.680	ms	TRW = 4965 FRC cycles, $T_A = +85^{\circ}\text{C}$ (Note 2)
D136b	TPE	Row Write Time	0.660	—	0.687	ms	TRW = 4965 FRC cycles, $T_A = +125^{\circ}\text{C}$ (Note 2)
D137a	TPE	Page Erase Time	19.6	20	20.1	ms	TPE = 146893 FRC cycles, $T_A = +85^{\circ}\text{C}$ (Note 2)
D137b	TPE	Page Erase Time	19.5	—	20.3	ms	TPE = 146893 FRC cycles, $T_A = +125^{\circ}\text{C}$ (Note 2)

Note 1: Data in “Typ” column is at 3.3V, $+25^{\circ}\text{C}$ unless otherwise stated.

2: Other conditions: FRC = 7.3728 MHz, TUN<5:0> = b'0111111 (for Min), TUN<5:0> = b'100000 (for Max). This parameter depends on the FRC accuracy (see [Table 33-19](#)) and the value of the FRC Oscillator Tuning register.

33.2 AC Characteristics and Timing Parameters

This section defines the dsPIC33EPXXXGM3XX/6XX/7XX AC characteristics and timing parameters.

TABLE 33-14: TEMPERATURE AND VOLTAGE SPECIFICATIONS – AC

AC CHARACTERISTICS	Standard Operating Conditions: 3.0V to 3.6V (unless otherwise stated)
	Operating temperature $-40^{\circ}\text{C} \leq T_A \leq +85^{\circ}\text{C}$ for Industrial $-40^{\circ}\text{C} \leq T_A \leq +125^{\circ}\text{C}$ for Extended Operating voltage V_{DD} range as described in Section 33.1 “DC Characteristics” .

FIGURE 33-1: LOAD CONDITIONS FOR DEVICE TIMING SPECIFICATIONS

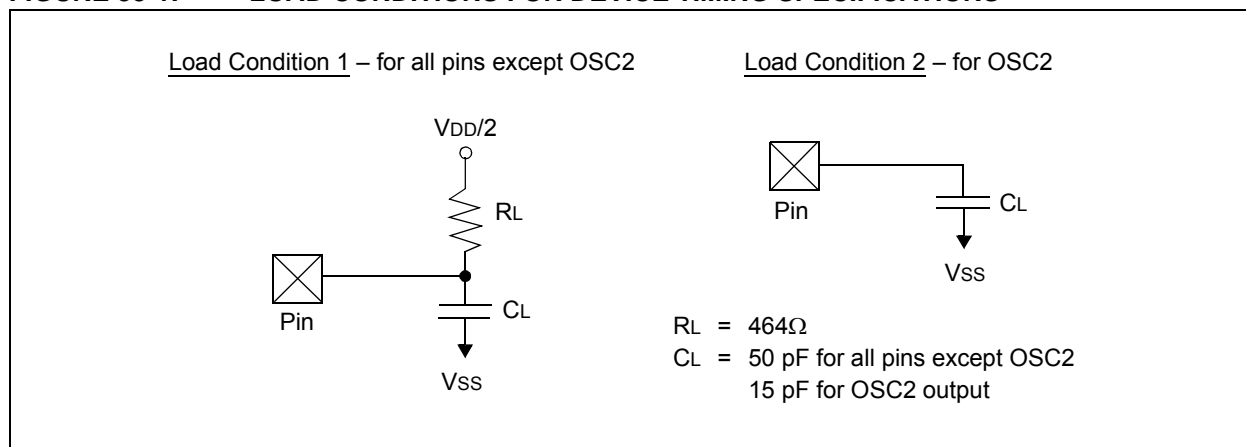

TABLE 33-15: CAPACITIVE LOADING REQUIREMENTS ON OUTPUT PINS

Param No.	Symbol	Characteristic	Min.	Typ.	Max.	Units	Conditions
DO50	Cosco	OSC2 Pin	—	—	15	pF	In XT and HS modes, when external clock is used to drive OSC1
DO56	Cio	All I/O Pins and OSC2	—	—	50	pF	EC mode
DO58	Cb	SCLx, SDAx	—	—	400	pF	In I ² C™ mode

dsPIC33EPXXXGM3XX/6XX/7XX

FIGURE 33-2: EXTERNAL CLOCK TIMING

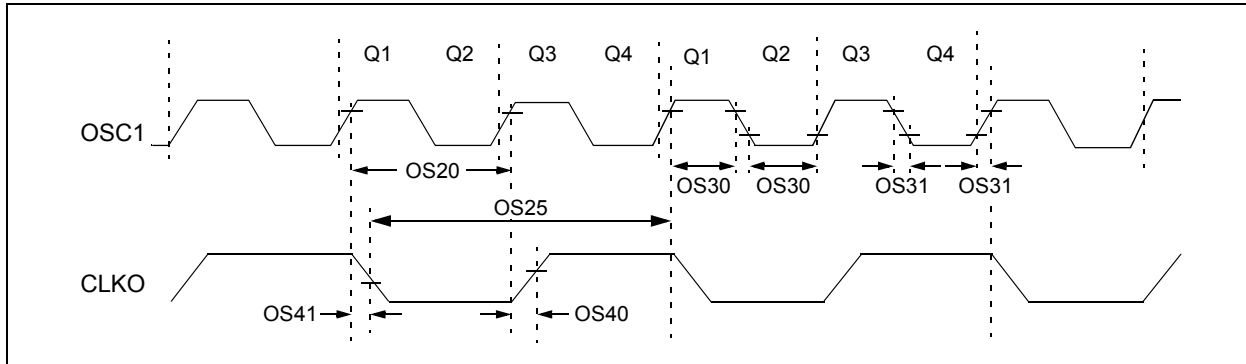

TABLE 33-16: EXTERNAL CLOCK TIMING REQUIREMENTS

AC CHARACTERISTICS			Standard Operating Conditions: 3.0V to 3.6V (unless otherwise stated) Operating temperature -40°C ≤ TA ≤ +85°C for Industrial -40°C ≤ TA ≤ +125°C for Extended				
Param No.	Symb	Characteristic	Min.	Typ. ⁽¹⁾	Max.	Units	Conditions
OS10	FIN	External CLKI Frequency (External clocks allowed only in EC and ECPLL modes)	DC	—	60	MHz	EC
		Oscillator Crystal Frequency	3.5 10 32.4	— — 32.768	10 25 33.1	MHz MHz kHz	XT HS SOSC
OS20	Tosc	Tosc = 1/Fosc	8.33	—	DC	ns	TA = +125°C
		Tosc = 1/Fosc	7.14	—	DC	ns	TA = +85°C
OS25	Tcy	Instruction Cycle Time ⁽²⁾	16.67	—	DC	ns	TA = +125°C
			14.28	—	DC	ns	TA = +85°C
OS30	TosL, TosH	External Clock in (OSC1) High or Low Time	0.375 x Tosc	—	0.625 x Tosc	ns	EC
OS31	TosR, TosF	External Clock in (OSC1) Rise or Fall Time	—	—	20	ns	EC
OS40	TckR	CLKO Rise Time ⁽³⁾	—	5.2	—	ns	
OS41	TckF	CLKO Fall Time ⁽³⁾	—	5.2	—	ns	
OS42	GM	External Oscillator Transconductance ⁽⁴⁾	—	12	—	mA/V	HS, VDD = 3.3V, TA = +25°C
			—	6	—	mA/V	XT, VDD = 3.3V, TA = +25°C

Note 1: Data in “Typical” column is at 3.3V, +25°C unless otherwise stated.

Note 2: Instruction cycle period (Tcy) equals two times the input oscillator time base period. All specified values are based on characterization data for that particular oscillator type under standard operating conditions with the device executing code. Exceeding these specified limits may result in an unstable oscillator operation and/or higher than expected current consumption. All devices are tested to operate at “Minimum” values with an external clock applied to the OSC1 pin. When an external clock input is used, the “Maximum” cycle time limit is “DC” (no clock) for all devices.

Note 3: Measurements are taken in EC mode. The CLKO signal is measured on the OSC2 pin.

Note 4: This parameter is characterized, but not tested in manufacturing.

TABLE 33-17: PLL CLOCK TIMING SPECIFICATIONS

AC CHARACTERISTICS			Standard Operating Conditions: 3.0V to 3.6V (unless otherwise stated) Operating temperature -40°C ≤ TA ≤ +85°C for Industrial -40°C ≤ TA ≤ +125°C for Extended				
Param No.	Symbol	Characteristic	Min.	Typ. ⁽¹⁾	Max.	Units	Conditions
OS50	FPLLI	PLL Voltage Controlled Oscillator (VCO) Input Frequency Range	0.8	—	8.0	MHz	ECPLL, XTPLL modes
OS51	FSYS	On-Chip VCO System Frequency	120	—	340	MHz	
OS52	TLOCK	PLL Start-up Time (Lock Time)	0.9	1.5	3.1	ms	
OS53	DCLK	CLKO Stability (Jitter) ⁽²⁾	-3	0.5	3	%	

- Note 1:** Data in “Typical” column is at 3.3V, +25°C unless otherwise stated. Parameters are for design guidance only and are not tested.
- 2:** This jitter specification is based on clock cycle-by-clock cycle measurements. To get the effective jitter for individual time bases or communication clocks used by the application, use the following formula:

$$Effective\ Jitter = \frac{DCLK}{\sqrt{\frac{FOSC}{Time\ Base\ or\ Communication\ Clock}}}$$

For example, if Fosc = 120 MHz and the SPI bit rate = 10 MHz, the effective jitter is as follows:

$$Effective\ Jitter = \frac{DCLK}{\sqrt{\frac{120}{10}}} = \frac{DCLK}{\sqrt{12}} = \frac{DCLK}{3.464}$$

TABLE 33-18: INTERNAL FRC ACCURACY

AC CHARACTERISTICS		Standard Operating Conditions: 3.0V to 3.6V (unless otherwise stated) Operating temperature -40°C ≤ TA ≤ +85°C for Industrial -40°C ≤ TA ≤ +125°C for Extended					
Param No.	Characteristic	Min.	Typ.	Max.	Units	Conditions	
Internal FRC Accuracy @ FRC Frequency = 7.3728 MHz⁽¹⁾							
F20a	FRC	-1.5	0.5	+1.5	%	-40°C ≤ TA ≤ +85°C	VDD = 3.0-3.6V
F20b	FRC	-2	1.5	+2	%	-40°C ≤ TA ≤ +125°C	VDD = 3.0-3.6V

- Note 1:** Frequency calibrated at +25°C and 3.3V. TUNx bits can be used to compensate for temperature drift.

TABLE 33-19: INTERNAL LPRC ACCURACY

AC CHARACTERISTICS		Standard Operating Conditions: 3.0V to 3.6V (unless otherwise stated) Operating temperature -40°C ≤ TA ≤ +85°C for Industrial -40°C ≤ TA ≤ +125°C for Extended					
Param No.	Characteristic	Min.	Typ.	Max.	Units	Conditions	
LPRC @ 32.768 kHz							
F21a	LPRC	-15	5	+15	%	-40°C ≤ TA ≤ +85°C	VDD = 3.0-3.6V
F21b	LPRC	-30	10	+30	%	-40°C ≤ TA ≤ +125°C	VDD = 3.0-3.6V

dsPIC33EPXXXGM3XX/6XX/7XX

FIGURE 33-3: I/O TIMING CHARACTERISTICS

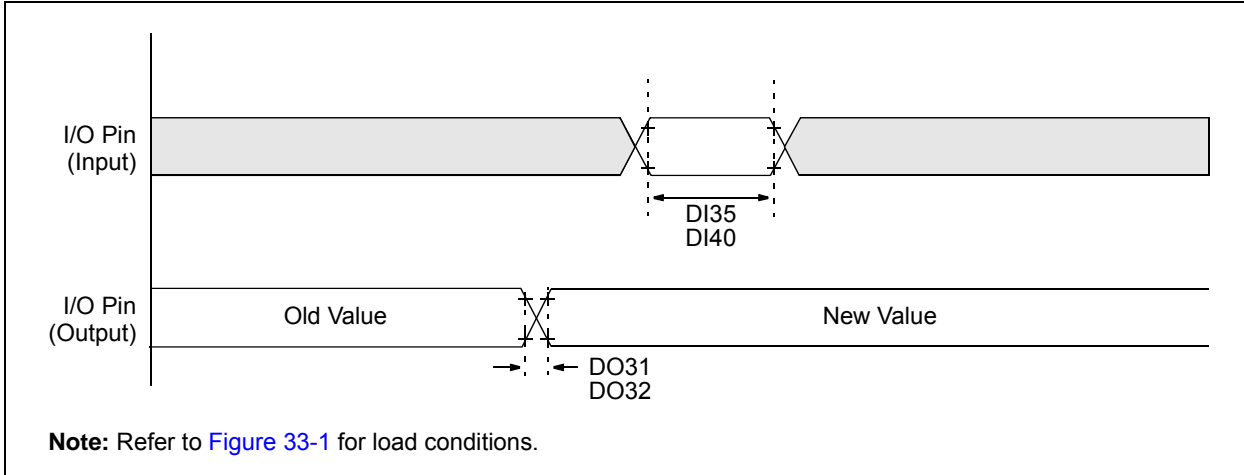

TABLE 33-20: I/O TIMING REQUIREMENTS

AC CHARACTERISTICS			Standard Operating Conditions: 3.0V to 3.6V (unless otherwise stated) Operating temperature $-40^{\circ}\text{C} \leq T_A \leq +85^{\circ}\text{C}$ for Industrial $-40^{\circ}\text{C} \leq T_A \leq +125^{\circ}\text{C}$ for Extended				
Param No.	Symbol	Characteristic	Min.	Typ. ⁽¹⁾	Max.	Units	Conditions
DO31	TioR	Port Output Rise Time	—	5	10	ns	
DO32	TioF	Port Output Fall Time	—	5	10	ns	
DI35	TINP	INTx Pin High or Low Time (input)	20	—	—	ns	
DI40	TRBP	CNx High or Low Time (input)	2	—	—	Tcy	

Note 1: Data in “Typical” column is at 3.3V, +25°C unless otherwise stated.

FIGURE 33-4: BOR AND MASTER CLEAR RESET TIMING CHARACTERISTICS

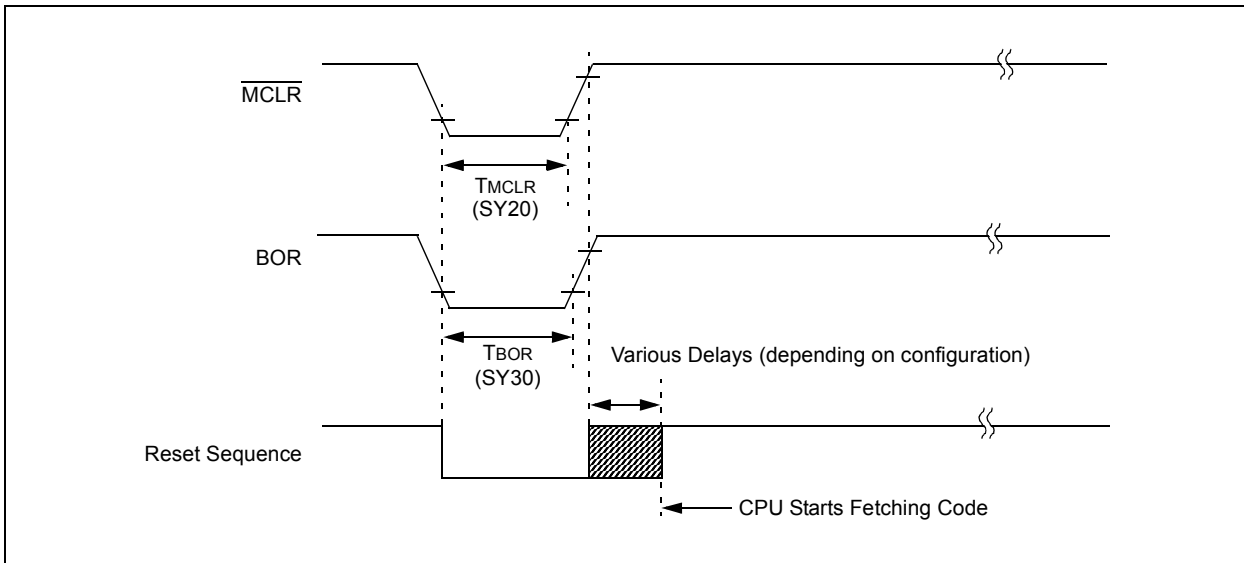
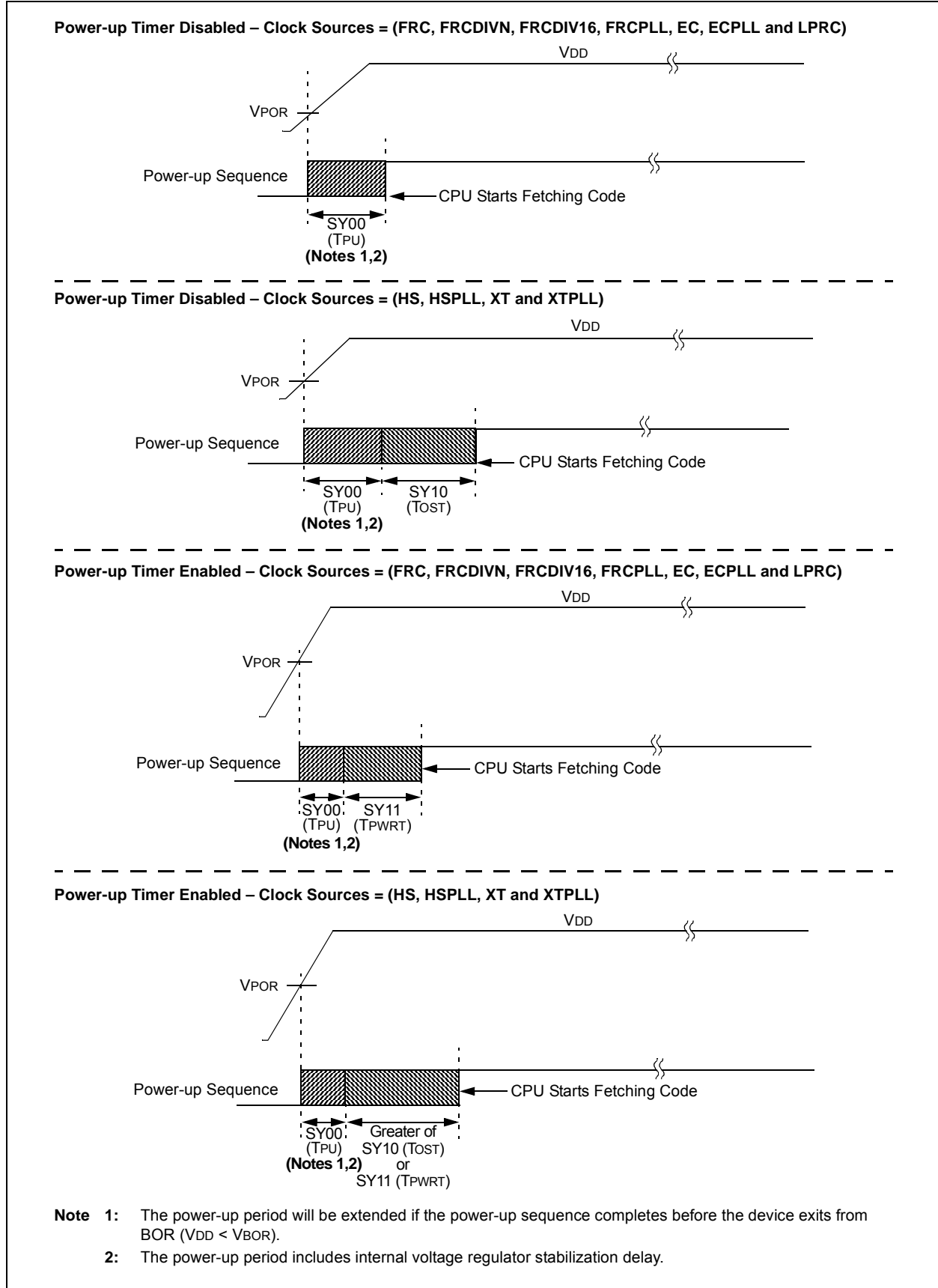

FIGURE 33-5: POWER-ON RESET TIMING CHARACTERISTICS



dsPIC33EPXXXGM3XX/6XX/7XX

TABLE 33-21: RESET, WATCHDOG TIMER, OSCILLATOR START-UP TIMER AND POWER-UP TIMER TIMING REQUIREMENTS

AC CHARACTERISTICS			Standard Operating Conditions: 3.0V to 3.6V (unless otherwise stated) Operating temperature -40°C ≤ TA ≤ +85°C for Industrial -40°C ≤ TA ≤ +125°C for Extended				
Param No.	Symbol	Characteristic ⁽¹⁾	Min.	Typ. ⁽²⁾	Max.	Units	Conditions
SY00	TPU	Power-up Period	—	400	600	μs	
SY10	TOST	Oscillator Start-up Time	—	1024 TOSC	—	—	TOSC = OSC1 period
SY12	TWDT	Watchdog Timer Time-out Period	0.85	—	1.15	ms	WDTPRE = 0, WDTPOST<3:0> = 0000, Using LPRC tolerances indicated in F21 (see Table 33-19) at +85°C
			3.4	—	4.6	ms	WDTPRE = 1, WDTPOST<3:0> = 0000, Using LPRC tolerances indicated in F21 (see Table 33-19) at +85°C
SY13	TIOZ	I/O High-Impedance from MCLR Low or Watchdog Timer Reset	0.68	0.72	1.2	μs	
SY20	TMCLR	MCLR Pulse Width (low)	2	—	—	μs	
SY30	TBOR	BOR Pulse Width (low)	1	—	—	μs	
SY35	TFSCM	Fail-Safe Clock Monitor Delay	—	500	900	μs	-40°C to +85°C
SY36	TVREG	Voltage Regulator Standby-to-Active Mode Transition Time	—	—	30	μs	
SY37	TOSCDFRC	FRC Oscillator Start-up Delay	—	—	29	μs	
SY38	TOSCDLPRC	LPRC Oscillator Start-up Delay	—	—	70	μs	

Note 1: These parameters are characterized but not tested in manufacturing.

2: Data in “Typical” column is at 3.3V, +25°C unless otherwise stated.

FIGURE 33-6: TIMER1-TIMER5 EXTERNAL CLOCK TIMING CHARACTERISTICS

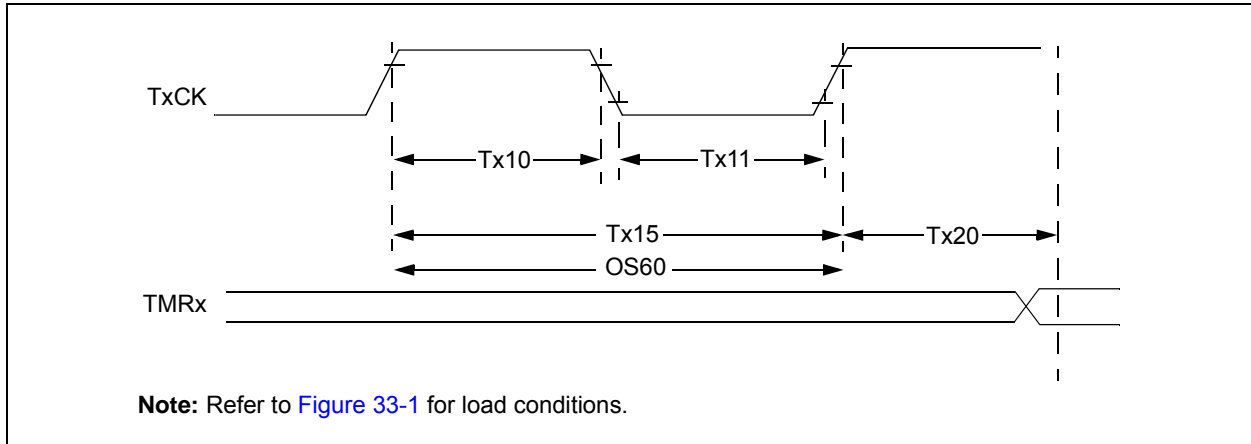

TABLE 33-22: TIMER1 EXTERNAL CLOCK TIMING REQUIREMENTS⁽¹⁾

AC CHARACTERISTICS			Standard Operating Conditions: 3.0V to 3.6V (unless otherwise stated) Operating temperature $-40^{\circ}\text{C} \leq T_A \leq +85^{\circ}\text{C}$ for Industrial $-40^{\circ}\text{C} \leq T_A \leq +125^{\circ}\text{C}$ for Extended					
Param No.	Symbol	Characteristic ⁽²⁾		Min.	Typ.	Max.	Units	Conditions
TA10	TtxH	T1CK High Time	Synchronous mode	Greater of: 20 or $(T_{CY} + 20)/N$	—	—	ns	Must also meet Parameter TA15, N = Prescaler value (1, 8, 64, 256)
			Asynchronous	35	—	—	ns	
TA11	TtxL	T1CK Low Time	Synchronous mode	Greater of: 20 or $(T_{CY} + 20)/N$	—	—	ns	Must also meet Parameter TA15, N = Prescaler value (1, 8, 64, 256)
			Asynchronous	10	—	—	ns	
TA15	TtxP	T1CK Input Period	Synchronous mode	Greater of: 40 or $(2 T_{CY} + 40)/N$	—	—	ns	N = Prescaler value (1, 8, 64, 256)
OS60	Ft1	T1CK Oscillator Input Frequency Range (oscillator enabled by setting TCS (T1CON<1>) bit)		DC	—	50	kHz	
TA20	TCKEXTMRL	Delay from External T1CK Clock Edge to Timer Increment		$0.75 T_{CY} + 40$	—	$1.75 T_{CY} + 40$	ns	

Note 1: Timer1 is a Type A.

Note 2: These parameters are characterized, but are not tested in manufacturing.

dsPIC33EPXXXGM3XX/6XX/7XX

TABLE 33-23: TIMER2 AND TIMER4 (TYPE B TIMER) EXTERNAL CLOCK TIMING REQUIREMENTS

AC CHARACTERISTICS				Standard Operating Conditions: 3.0V to 3.6V (unless otherwise stated) Operating temperature $-40^{\circ}\text{C} \leq T_A \leq +85^{\circ}\text{C}$ for Industrial $-40^{\circ}\text{C} \leq T_A \leq +125^{\circ}\text{C}$ for Extended				
Param No.	Symbol	Characteristic ⁽¹⁾		Min.	Typ.	Max.	Units	Conditions
TB10	TtXH	TxCK High Time	Synchronous mode	Greater of: 20 or (Tcy + 20)/N	—	—	ns	Must also meet Parameter TB15, N = Prescale value (1, 8, 64, 256)
TB11	TtXL	TxCK Low Time	Synchronous mode	Greater of: 20 or (Tcy + 20)/N	—	—	ns	Must also meet Parameter TB15, N = Prescale value (1, 8, 64, 256)
TB15	TtXP	TxCK Input Period	Synchronous mode	Greater of: 40 or (2 Tcy + 40)/N	—	—	ns	N = Prescale value (1, 8, 64, 256)
TB20	TCKEXTMRL	Delay from External TxCK Clock Edge to Timer Increment		0.75 Tcy + 40	—	1.75 Tcy + 40	ns	

Note 1: These parameters are characterized, but are not tested in manufacturing.

TABLE 33-24: TIMER3 AND TIMER5 (TYPE C TIMER) EXTERNAL CLOCK TIMING REQUIREMENTS

AC CHARACTERISTICS				Standard Operating Conditions: 3.0V to 3.6V (unless otherwise stated) Operating temperature $-40^{\circ}\text{C} \leq T_A \leq +85^{\circ}\text{C}$ for Industrial $-40^{\circ}\text{C} \leq T_A \leq +125^{\circ}\text{C}$ for Extended				
Param No.	Symbol	Characteristic ⁽¹⁾		Min.	Typ.	Max.	Units	Conditions
TC10	TtXH	TxCK High Time	Synchronous	Tcy + 20	—	—	ns	Must also meet Parameter TC15
TC11	TtXL	TxCK Low Time	Synchronous	Tcy + 20	—	—	ns	Must also meet Parameter TC15
TC15	TtXP	TxCK Input Period	Synchronous, with Prescaler	2 Tcy + 40	—	—	ns	N = Prescale value (1, 8, 64, 256)
TC20	TCKEXTMRL	Delay from External TxCK Clock Edge to Timer Increment		0.75 Tcy + 40	—	1.75 Tcy + 40	ns	

Note 1: These parameters are characterized, but are not tested in manufacturing.

FIGURE 33-7: INPUT CAPTURE x (ICx) TIMING CHARACTERISTICS

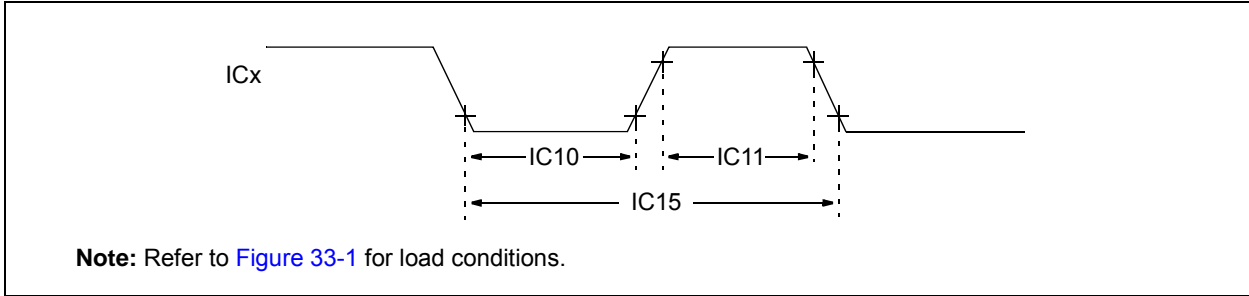

TABLE 33-25: INPUT CAPTURE x (ICx) TIMING REQUIREMENTS

AC CHARACTERISTICS			Standard Operating Conditions: 3.0V to 3.6V (unless otherwise stated) Operating temperature $-40^{\circ}\text{C} \leq T_A \leq +85^{\circ}\text{C}$ for Industrial $-40^{\circ}\text{C} \leq T_A \leq +125^{\circ}\text{C}$ for Extended			
Param. No.	Symbol	Characteristics ⁽¹⁾	Min.	Max.	Units	Conditions
IC10	TccL	ICx Input Low Time	Greater of: $12.5 + 25$ or $(0.5 T_{CY}/N) + 25$	—	ns	Must also meet Parameter IC15
IC11	TccH	ICx Input High Time	Greater of: $12.5 + 25$ or $(0.5 T_{CY}/N) + 25$	—	ns	Must also meet Parameter IC15
IC15	TccP	ICx Input Period	Greater of: $25 + 50$ or $(1 T_{CY}/N) + 50$	—	ns	

N = Prescale value (1, 4, 16)

Note 1: These parameters are characterized, but not tested in manufacturing.

dsPIC33EPXXXGM3XX/6XX/7XX

FIGURE 33-8: OUTPUT COMPARE x (OCx) TIMING CHARACTERISTICS

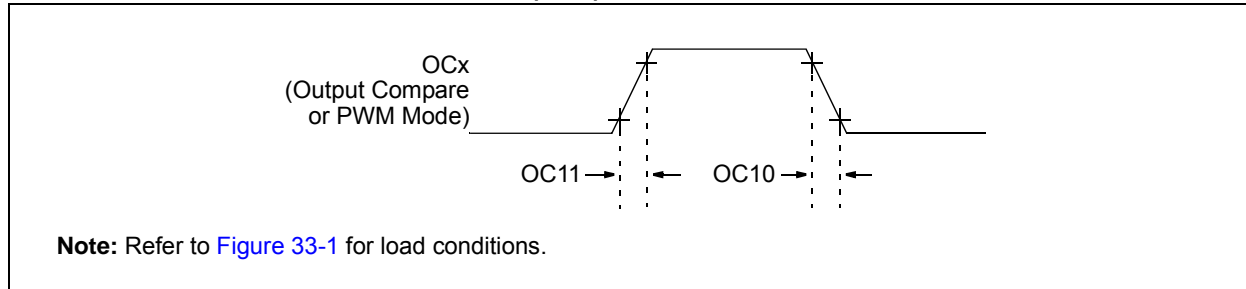

TABLE 33-26: OUTPUT COMPARE x (OCx) TIMING REQUIREMENTS

AC CHARACTERISTICS			Standard Operating Conditions: 3.0V to 3.6V (unless otherwise stated) Operating temperature $-40^{\circ}\text{C} \leq T_A \leq +85^{\circ}\text{C}$ for Industrial $-40^{\circ}\text{C} \leq T_A \leq +125^{\circ}\text{C}$ for Extended				
Param No.	Symbol	Characteristic ⁽¹⁾	Min.	Typ.	Max.	Units	Conditions
OC10	TccF	OCx Output Fall Time	—	—	—	ns	See Parameter DO32
OC11	TccR	OCx Output Rise Time	—	—	—	ns	See Parameter DO31

Note 1: These parameters are characterized but not tested in manufacturing.

FIGURE 33-9: OCx/PWMx MODULE TIMING CHARACTERISTICS

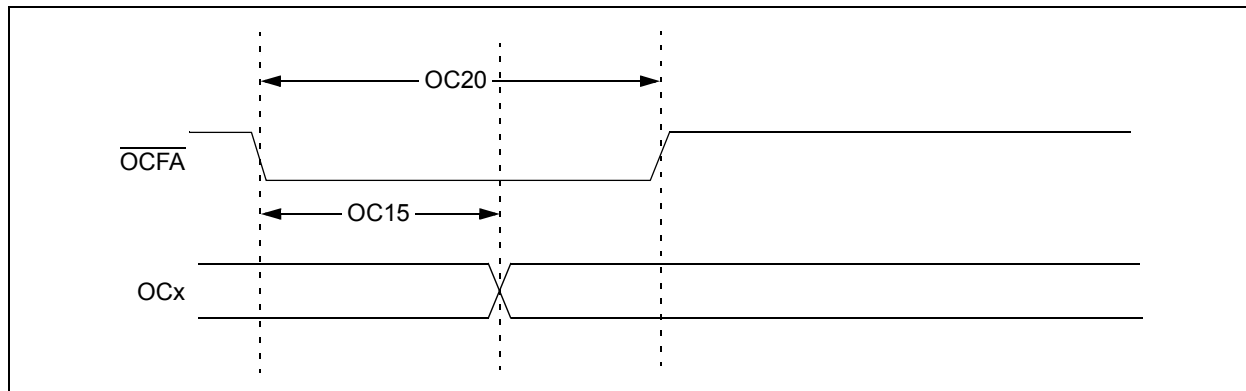

TABLE 33-27: OCx/PWMx MODE TIMING REQUIREMENTS

AC CHARACTERISTICS			Standard Operating Conditions: 3.0V to 3.6V (unless otherwise stated) Operating temperature $-40^{\circ}\text{C} \leq T_A \leq +85^{\circ}\text{C}$ for Industrial $-40^{\circ}\text{C} \leq T_A \leq +125^{\circ}\text{C}$ for Extended				
Param No.	Symbol	Characteristic ⁽¹⁾	Min.	Typ.	Max.	Units	Conditions
OC15	TFD	Fault Input to PWMx I/O Change	—	—	$T_{CY} + 20$	ns	
OC20	TFLT	Fault Input Pulse Width	$T_{CY} + 20$	—	—	ns	

Note 1: These parameters are characterized but not tested in manufacturing.

FIGURE 33-10: HIGH-SPEED PWMx MODULE FAULT TIMING CHARACTERISTICS

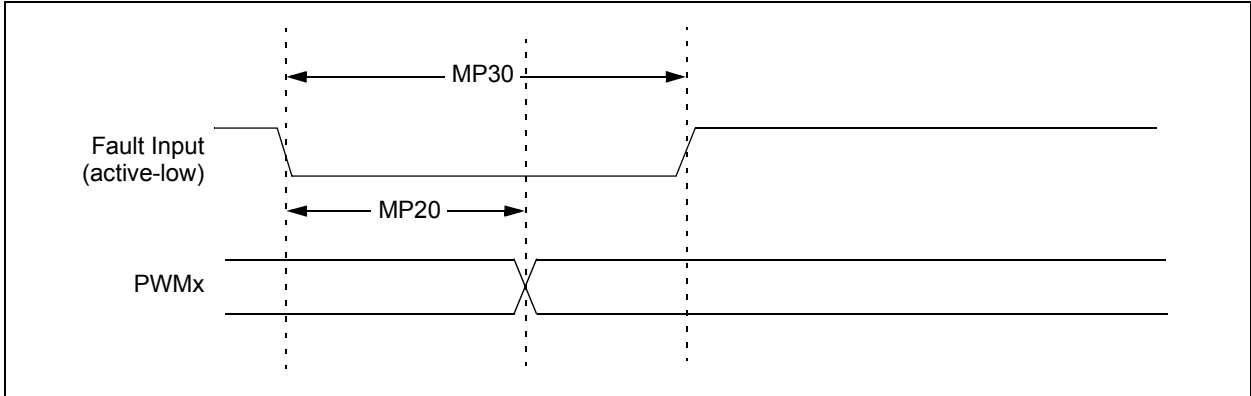
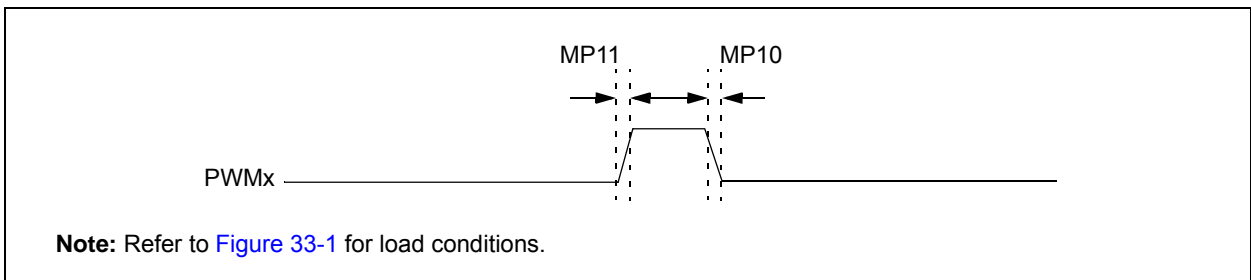

FIGURE 33-11: HIGH-SPEED PWMx MODULE TIMING CHARACTERISTICS



Note: Refer to [Figure 33-1](#) for load conditions.

TABLE 33-28: HIGH-SPEED PWMx MODULE TIMING REQUIREMENTS

AC CHARACTERISTICS			Standard Operating Conditions: 3.0V to 3.6V (unless otherwise stated) Operating temperature $-40^{\circ}\text{C} \leq T_A \leq +85^{\circ}\text{C}$ for Industrial $-40^{\circ}\text{C} \leq T_A \leq +125^{\circ}\text{C}$ for Extended				
Param No.	Symbol	Characteristic ⁽¹⁾	Min.	Typ.	Max.	Units	Conditions
MP10	T _{FPWM}	PWMx Output Fall Time	—	—	—	ns	See Parameter DO32
MP11	T _{RPWM}	PWMx Output Rise Time	—	—	—	ns	See Parameter DO31
MP20	T _{FD}	Fault Input ↓ to PWMx I/O Change	—	—	15	ns	
MP30	T _{FH}	Fault Input Pulse Width	15	—	—	ns	

Note 1: These parameters are characterized but not tested in manufacturing.

dsPIC33EPXXXGM3XX/6XX/7XX

FIGURE 33-12: TIMERQ (QEIX MODULE) EXTERNAL CLOCK TIMING CHARACTERISTICS

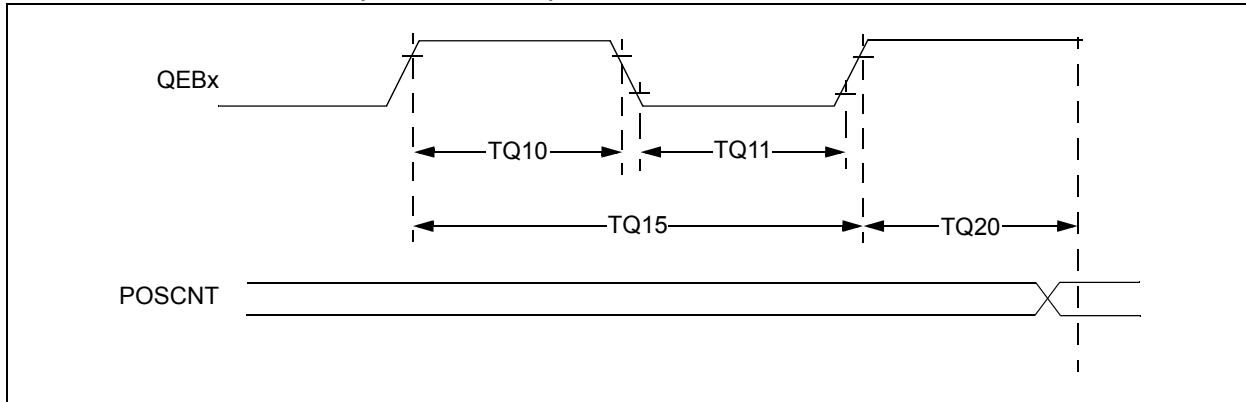

TABLE 33-29: QEIX MODULE EXTERNAL CLOCK TIMING REQUIREMENTS

AC CHARACTERISTICS				Standard Operating Conditions: 3.0V to 3.6V (unless otherwise stated) Operating temperature $-40^{\circ}\text{C} \leq T_A \leq +85^{\circ}\text{C}$ for Industrial $-40^{\circ}\text{C} \leq T_A \leq +125^{\circ}\text{C}$ for Extended				
Param No.	Symbol	Characteristic ⁽¹⁾		Min.	Typ.	Max.	Units	Conditions
TQ10	TtQH	TQCK High Time	Synchronous, with Prescaler	Greater of: $12.5 + 25$ or $(0.5 T_{CY}/N) + 25$	—	—	ns	Must also meet Parameter TQ15
TQ11	TtQL	TQCK Low Time	Synchronous, with Prescaler	Greater of: $12.5 + 25$ or $(0.5 T_{CY}/N) + 25$	—	—	ns	Must also meet Parameter TQ15
TQ15	TtQP	TQCP Input Period	Synchronous, with Prescaler	Greater of: $25 + 50$ or $(1 T_{CY}/N) + 50$	—	—	ns	
TQ20	TCKEXTMRL	Delay from External TxCK Clock Edge to Timer Increment		—	1	T _{CY}	—	

Note 1: These parameters are characterized but not tested in manufacturing.

FIGURE 33-13: QEAx/QEBx INPUT CHARACTERISTICS

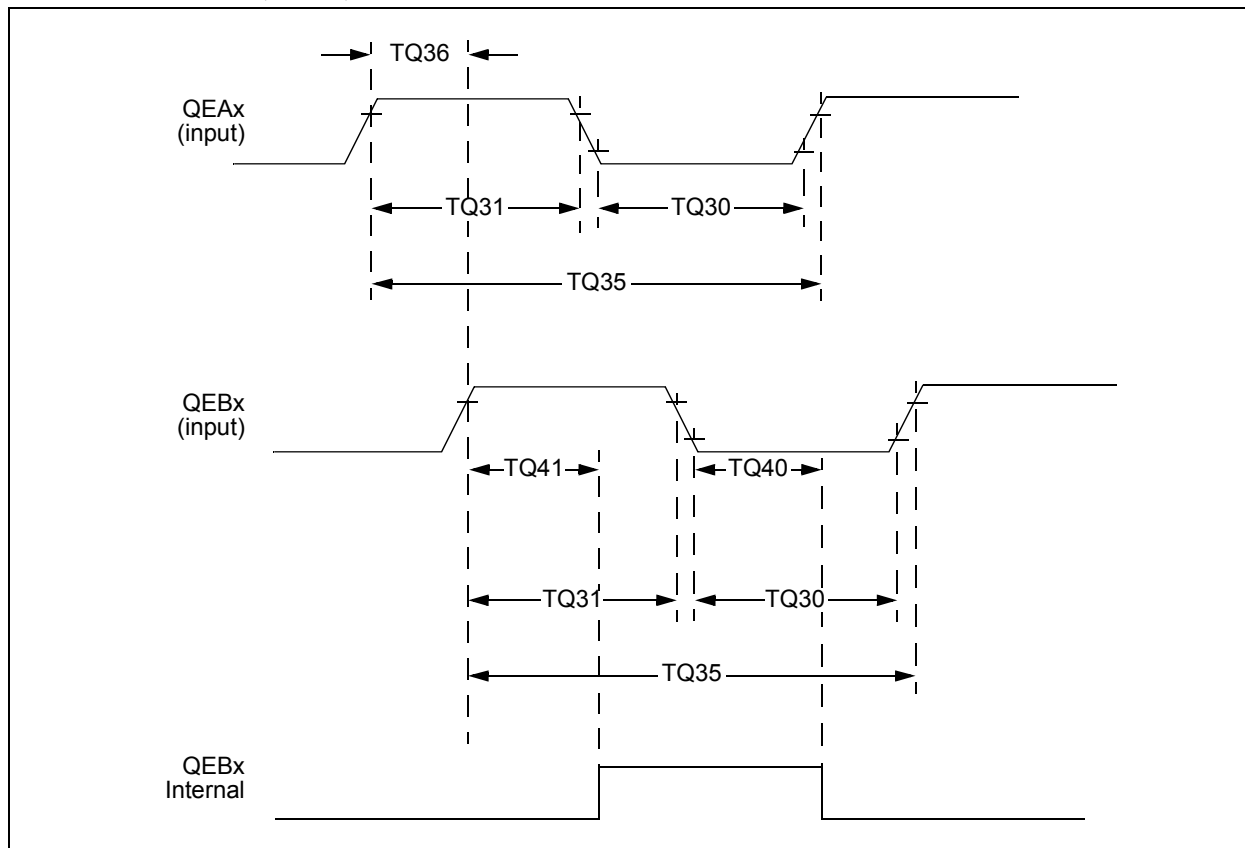

TABLE 33-30: QUADRATURE DECODER TIMING REQUIREMENTS

AC CHARACTERISTICS			Standard Operating Conditions: 3.0V to 3.6V (unless otherwise stated) Operating temperature $-40^{\circ}\text{C} \leq T_A \leq +85^{\circ}\text{C}$ for Industrial $-40^{\circ}\text{C} \leq T_A \leq +125^{\circ}\text{C}$ for Extended			
Param No.	Symbol	Characteristic ⁽¹⁾	Typ. ⁽²⁾	Max.	Units	Conditions
TQ30	TQuL	Quadrature Input Low Time	6 TcY	—	ns	
TQ31	TQuH	Quadrature Input High Time	6 TcY	—	ns	
TQ35	TQuIN	Quadrature Input Period	12 TcY	—	ns	
TQ36	TQuP	Quadrature Phase Period	3 TcY	—	ns	
TQ40	TQuFL	Filter Time to Recognize Low with Digital Filter	$3 * N * TcY$	—	ns	N = 1, 2, 4, 16, 32, 64, 128 and 256 (Note 3)
TQ41	TQuFH	Filter Time to Recognize High with Digital Filter	$3 * N * TcY$	—	ns	N = 1, 2, 4, 16, 32, 64, 128 and 256 (Note 3)

Note 1: These parameters are characterized but not tested in manufacturing.

2: Data in “Typical” column is at 3.3V, +25°C unless otherwise stated. Parameters are for design guidance only and are not tested.

3: N = Index Channel Digital Filter Clock Divide Select bits. Refer to the “dsPIC33/PIC24 Family Reference Manual”, “**Quadrature Encoder Interface (QEI)**” (DS70601). Please see the Microchip web site for the latest “dsPIC33/PIC24 Family Reference Manual” sections.

dsPIC33EPXXXGM3XX/6XX/7XX

FIGURE 33-14: QEix MODULE INDEX PULSE TIMING CHARACTERISTICS

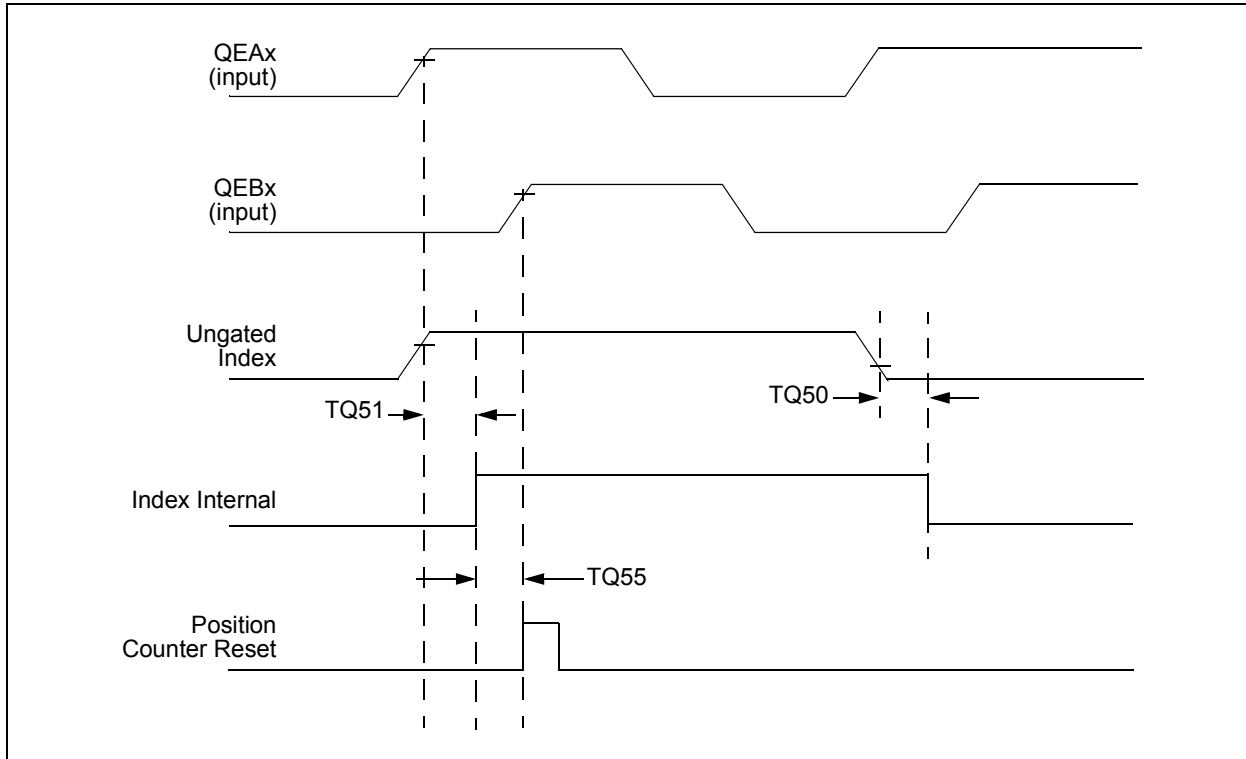

TABLE 33-31: QEix INDEX PULSE TIMING REQUIREMENTS

AC CHARACTERISTICS			Standard Operating Conditions: 3.0V to 3.6V (unless otherwise stated) Operating temperature $-40^{\circ}\text{C} \leq T_A \leq +85^{\circ}\text{C}$ for Industrial $-40^{\circ}\text{C} \leq T_A \leq +125^{\circ}\text{C}$ for Extended			
Param No.	Symbol	Characteristic ⁽¹⁾	Min.	Max.	Units	Conditions
TQ50	TqIL	Filter Time to Recognize Low with Digital Filter	$3 * N * T_{CY}$	—	ns	N = 1, 2, 4, 16, 32, 64, 128 and 256 (Note 2)
TQ51	TqiH	Filter Time to Recognize High with Digital Filter	$3 * N * T_{CY}$	—	ns	N = 1, 2, 4, 16, 32, 64, 128 and 256 (Note 2)
TQ55	Tqidxr	Index Pulse Recognized to Position Counter Reset (ungated index)	$3 T_{CY}$	—	ns	

Note 1: These parameters are characterized but not tested in manufacturing.

Note 2: Alignment of index pulses to QEAx and QEBx is shown for Position Counter Reset timing only. Shown for forward direction only (QEAx leads QEBx). Same timing applies for reverse direction (QEAx lags QEBx) but index pulse recognition occurs on falling edge.

TABLE 33-32: SPI2 AND SPI3 MAXIMUM DATA/CLOCK RATE SUMMARY

AC CHARACTERISTICS				Standard Operating Conditions: 3.0V to 3.6V (unless otherwise stated) Operating temperature -40°C ≤ TA ≤ +85°C for Industrial -40°C ≤ TA ≤ +125°C for Extended		
Maximum Data Rate	Master Transmit Only (Half-Duplex)	Master Transmit/Receive (Full-Duplex)	Slave Transmit/Receive (Full-Duplex)	CKE	CKP	SMP
15 MHz	Table 33-33	—	—	0,1	0,1	0,1
9 MHz	—	Table 33-34	—	1	0,1	1
9 MHz	—	Table 33-35	—	0	0,1	1
15 MHz	—	—	Table 33-36	1	0	0
11 MHz	—	—	Table 33-37	1	1	0
15 MHz	—	—	Table 33-38	0	1	0
11 MHz	—	—	Table 33-39	0	0	0

FIGURE 33-15: SPI2 AND SPI3 MASTER MODE (HALF-DUPLEX, TRANSMIT ONLY, CKE = 0) TIMING CHARACTERISTICS

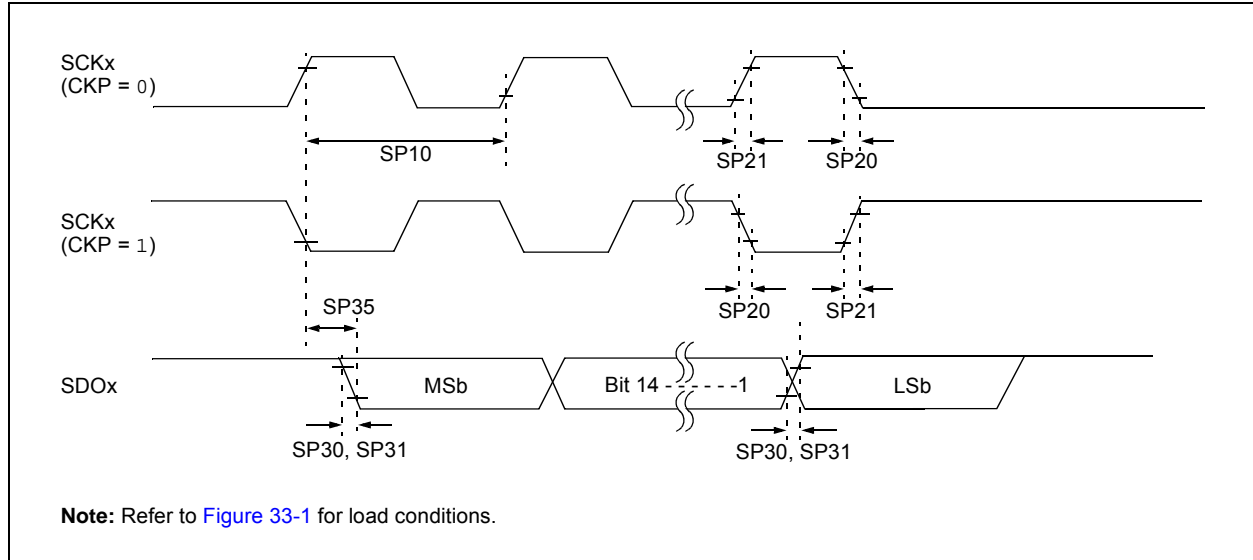

dsPIC33EPXXXGM3XX/6XX/7XX

FIGURE 33-16: SPI2 AND SPI3 MASTER MODE (HALF-DUPLEX, TRANSMIT ONLY, CKE = 1) TIMING CHARACTERISTICS

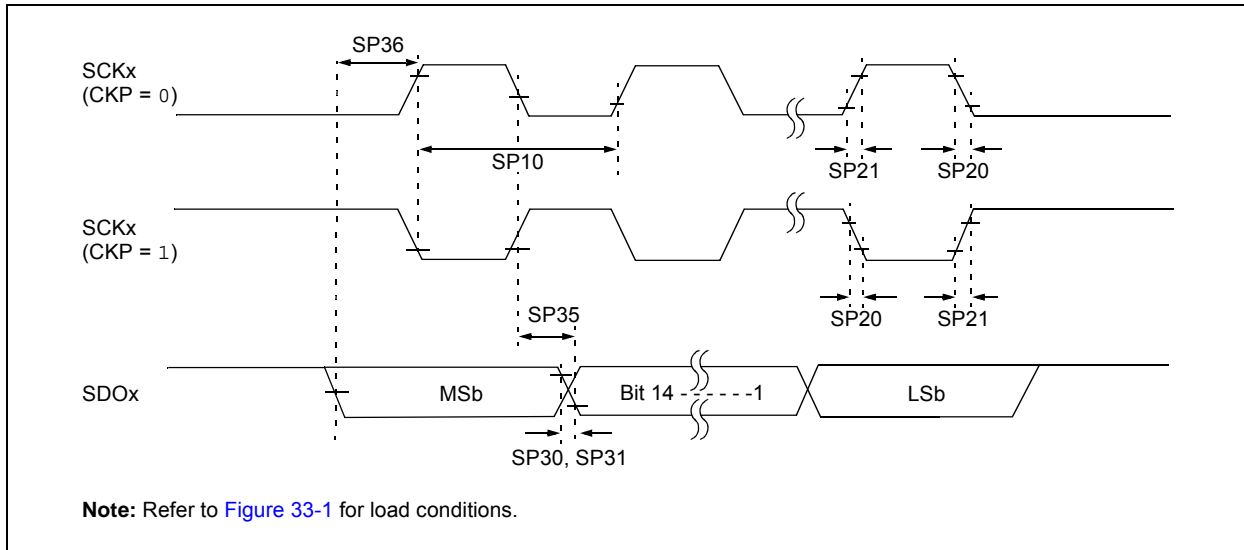

TABLE 33-33: SPI2 AND SPI3 MASTER MODE (HALF-DUPLEX, TRANSMIT ONLY) TIMING REQUIREMENTS

AC CHARACTERISTICS			Standard Operating Conditions: 3.0V to 3.6V (unless otherwise stated) Operating temperature $-40^{\circ}\text{C} \leq T_A \leq +85^{\circ}\text{C}$ for Industrial $-40^{\circ}\text{C} \leq T_A \leq +125^{\circ}\text{C}$ for Extended				
Param.	Symbol	Characteristic ⁽¹⁾	Min.	Typ. ⁽²⁾	Max.	Units	Conditions
SP10	FscP	Maximum SCKx Frequency	—	—	15	MHz	(Note 3)
SP20	TscF	SCKx Output Fall Time	—	—	—	ns	See Parameter DO32 (Note 4)
SP21	TscR	SCKx Output Rise Time	—	—	—	ns	See Parameter DO31 (Note 4)
SP30	TdoF	SDOx Data Output Fall Time	—	—	—	ns	See Parameter DO32 (Note 4)
SP31	TdoR	SDOx Data Output Rise Time	—	—	—	ns	See Parameter DO31 (Note 4)
SP35	Tsch2doV, TscL2doV	SDOx Data Output Valid after SCKx Edge	—	6	20	ns	
SP36	TdiV2scH, TdiV2scL	SDOx Data Output Setup to First SCKx Edge	30	—	—	ns	

Note 1: These parameters are characterized, but are not tested in manufacturing.

Note 2: Data in "Typical" column is at 3.3V, +25°C unless otherwise stated.

Note 3: The minimum clock period for SCKx is 66.7 ns. Therefore, the clock generated in Master mode must not violate this specification.

Note 4: Assumes 50 pF load on all SPIx pins.

FIGURE 33-17: SPI2 AND SPI3 MASTER MODE (FULL-DUPLEX, CKE = 1, CKP = x, SMP = 1) TIMING CHARACTERISTICS

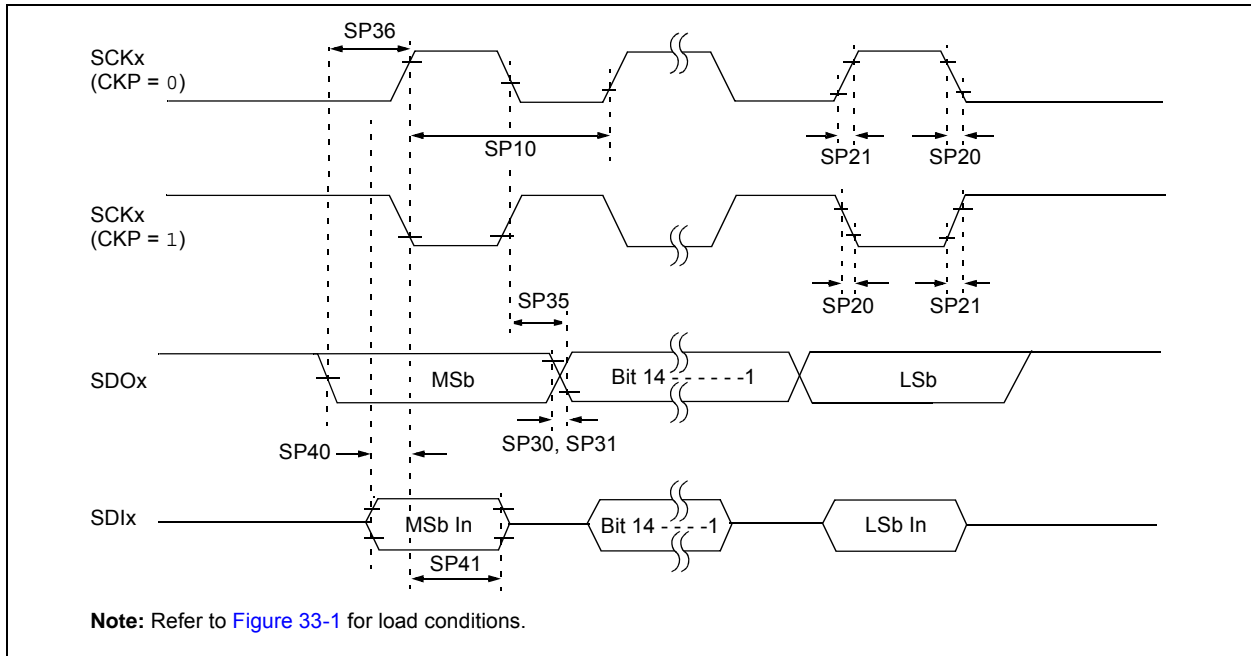

TABLE 33-34: SPI2 AND SPI3 MASTER MODE (FULL-DUPLEX, CKE = 1, CKP = x, SMP = 1) TIMING REQUIREMENTS

AC CHARACTERISTICS			Standard Operating Conditions: 3.0V to 3.6V (unless otherwise stated) Operating temperature -40°C ≤ Ta ≤ +85°C for Industrial -40°C ≤ Ta ≤ +125°C for Extended				
Param.	Symbol	Characteristic ⁽¹⁾	Min.	Typ. ⁽²⁾	Max.	Units	Conditions
SP10	FscP	Maximum SCKx Frequency	—	—	9	MHz	(Note 3)
SP20	TscF	SCKx Output Fall Time	—	—	—	ns	See Parameter DO32 (Note 4)
SP21	TscR	SCKx Output Rise Time	—	—	—	ns	See Parameter DO31 (Note 4)
SP30	TdoF	SDOx Data Output Fall Time	—	—	—	ns	See Parameter DO32 (Note 4)
SP31	TdoR	SDOx Data Output Rise Time	—	—	—	ns	See Parameter DO31 (Note 4)
SP35	Tsch2doV, TscL2doV	SDOx Data Output Valid after SCKx Edge	—	6	20	ns	
SP36	TdoV2sc, TdoV2scL	SDOx Data Output Setup to First SCKx Edge	30	—	—	ns	
SP40	TdiV2sch, TdiV2scL	Setup Time of SDIx Data Input to SCKx Edge	30	—	—	ns	
SP41	Tsch2diL, TscL2diL	Hold Time of SDIx Data Input to SCKx Edge	30	—	—	ns	

- Note 1:** These parameters are characterized, but are not tested in manufacturing.
Note 2: Data in “Typical” column is at 3.3V, +25°C unless otherwise stated.
Note 3: The minimum clock period for SCKx is 111 ns. The clock generated in Master mode must not violate this specification.
Note 4: Assumes 50 pF load on all SPIx pins.

dsPIC33EPXXXGM3XX/6XX/7XX

FIGURE 33-18: SPI2 AND SPI3 MASTER MODE (FULL-DUPLEX, CKE = 0, CKP = x, SMP = 1) TIMING CHARACTERISTICS

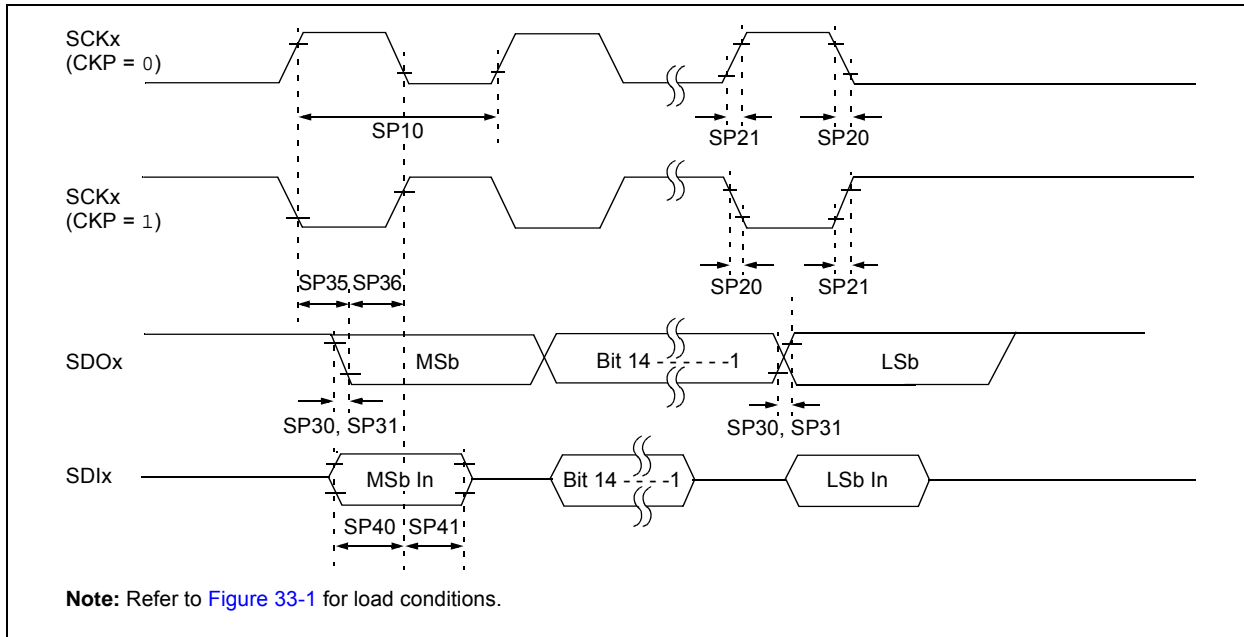

TABLE 33-35: SPI2 AND SPI3 MASTER MODE (FULL-DUPLEX, CKE = 0, CKP = x, SMP = 1) TIMING REQUIREMENTS

AC CHARACTERISTICS			Standard Operating Conditions: 3.0V to 3.6V (unless otherwise stated) Operating temperature -40°C ≤ TA ≤ +85°C for Industrial -40°C ≤ TA ≤ +125°C for Extended				
Param.	Symbol	Characteristic ⁽¹⁾	Min.	Typ. ⁽²⁾	Max.	Units	Conditions
SP10	FscP	Maximum SCKx Frequency	—	—	9	MHz	-40°C to +125°C (Note 3)
SP20	TscF	SCKx Output Fall Time	—	—	—	ns	See Parameter DO32 (Note 4)
SP21	TscR	SCKx Output Rise Time	—	—	—	ns	See Parameter DO31 (Note 4)
SP30	TdoF	SDOx Data Output Fall Time	—	—	—	ns	See Parameter DO32 (Note 4)
SP31	TdoR	SDOx Data Output Rise Time	—	—	—	ns	See Parameter DO31 (Note 4)
SP35	Tsch2doV, TscL2doV	SDOx Data Output Valid after SCKx Edge	—	6	20	ns	
SP36	TdoV2scH, TdoV2scL	SDOx Data Output Setup to First SCKx Edge	30	—	—	ns	
SP40	TdiV2scH, TdiV2scL	Setup Time of SDIx Data Input to SCKx Edge	30	—	—	ns	
SP41	Tsch2diL, TscL2diL	Hold Time of SDIx Data Input to SCKx Edge	30	—	—	ns	

Note 1: These parameters are characterized, but are not tested in manufacturing.

2: Data in “Typical” column is at 3.3V, +25°C unless otherwise stated.

3: The minimum clock period for SCKx is 111 ns. The clock generated in Master mode must not violate this specification.

4: Assumes 50 pF load on all SPIx pins.

FIGURE 33-19: SPI2 AND SPI3 SLAVE MODE (FULL-DUPLEX, CKE = 1, CKP = 0, SMP = 0) TIMING CHARACTERISTICS

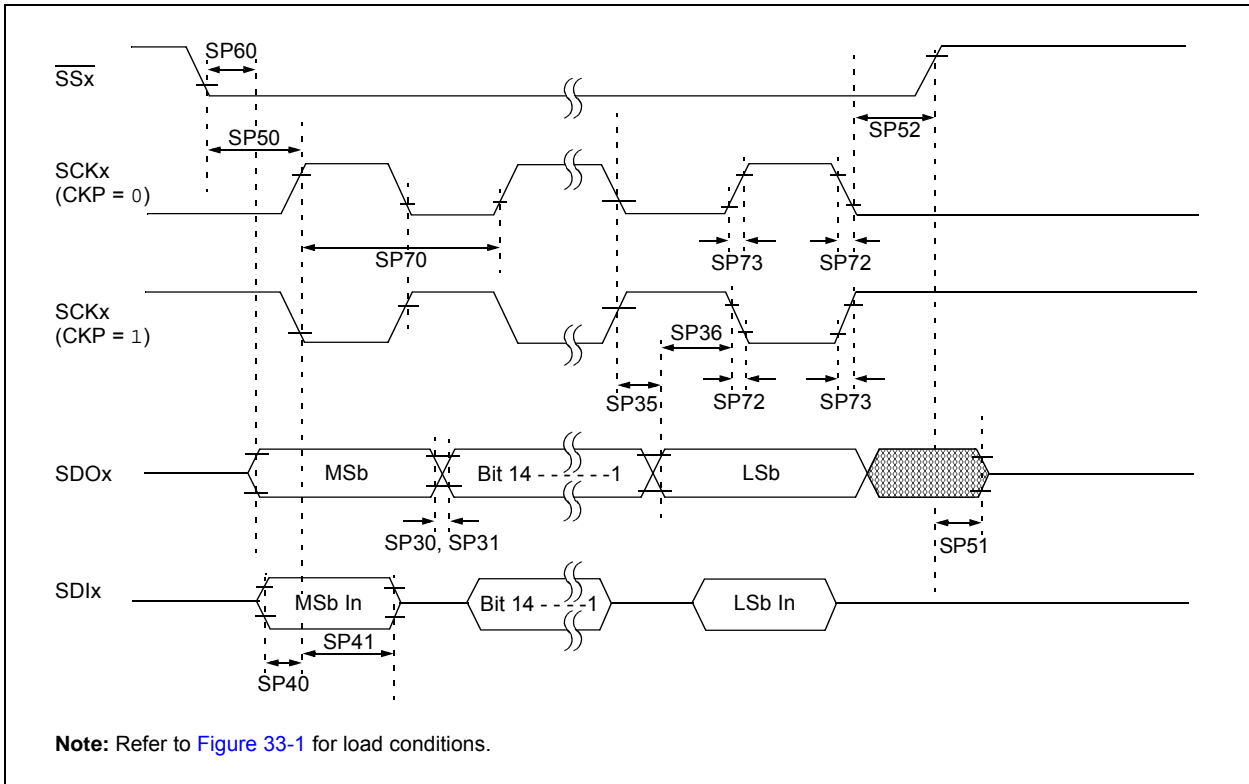

dsPIC33EPXXXGM3XX/6XX/7XX

**TABLE 33-36: SPI2 AND SPI3 SLAVE MODE (FULL-DUPLEX, CKE = 1, CKP = 0, SMP = 0)
TIMING REQUIREMENTS**

AC CHARACTERISTICS			Standard Operating Conditions: 3.0V to 3.6V (unless otherwise stated) Operating temperature -40°C ≤ TA ≤ +85°C for Industrial -40°C ≤ TA ≤ +125°C for Extended				
Param.	Symbol	Characteristic ⁽¹⁾	Min.	Typ. ⁽²⁾	Max.	Units	Conditions
SP70	FscP	Maximum SCKx Input Frequency	—	—	15	MHz	(Note 3)
SP72	TscF	SCKx Input Fall Time	—	—	—	ns	See Parameter DO32 (Note 4)
SP73	TscR	SCKx Input Rise Time	—	—	—	ns	See Parameter DO31 (Note 4)
SP30	TdoF	SDOx Data Output Fall Time	—	—	—	ns	See Parameter DO32 (Note 4)
SP31	TdoR	SDOx Data Output Rise Time	—	—	—	ns	See Parameter DO31 (Note 4)
SP35	Tsch2doV, TscL2doV	SDOx Data Output Valid after SCKx Edge	—	6	20	ns	
SP36	TdoV2scH, TdoV2scL	SDOx Data Output Setup to First SCKx Edge	30	—	—	ns	
SP40	TdiV2scH, TdiV2scL	Setup Time of SDIx Data Input to SCKx Edge	30	—	—	ns	
SP41	Tsch2diL, TscL2diL	Hold Time of SDIx Data Input to SCKx Edge	30	—	—	ns	
SP50	TssL2scH, TssL2scL	\overline{SSx} ↓ to SCKx ↑ or SCKx ↓ Input	120	—	—	ns	
SP51	TssH2doZ	\overline{SSx} ↑ to SDOx Output High-Impedance	10	—	50	ns	(Note 4)
SP52	Tsch2ssH TscL2ssH	\overline{SSx} ↑ after SCKx Edge	1.5 Tcy + 40	—	—	ns	(Note 4)
SP60	TssL2doV	SDOx Data Output Valid after \overline{SSx} Edge	—	—	50	ns	

Note 1: These parameters are characterized, but are not tested in manufacturing.

Note 2: Data in “Typical” column is at 3.3V, +25°C unless otherwise stated.

Note 3: The minimum clock period for SCKx is 66.7 ns. Therefore, the SCKx clock generated by the master must not violate this specification.

Note 4: Assumes 50 pF load on all SPIx pins.

FIGURE 33-20: SPI2 AND SPI3 SLAVE MODE (FULL-DUPLEX, CKE = 1, CKP = 1, SMP = 0) TIMING CHARACTERISTICS

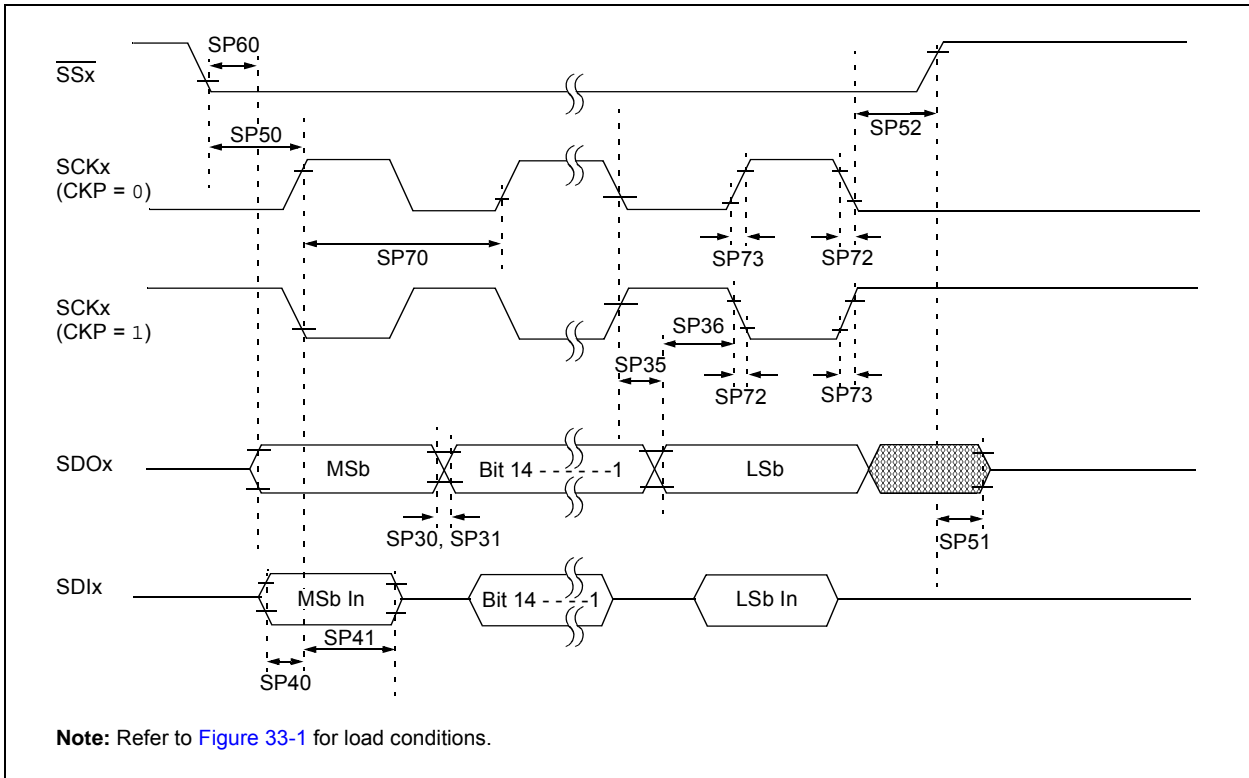

dsPIC33EPXXXGM3XX/6XX/7XX

**TABLE 33-37: SPI2 AND SPI3 SLAVE MODE (FULL-DUPLEX, CKE = 1, CKP = 1, SMP = 0)
TIMING REQUIREMENTS**

AC CHARACTERISTICS			Standard Operating Conditions: 3.0V to 3.6V (unless otherwise stated) Operating temperature $-40^{\circ}\text{C} \leq T_A \leq +85^{\circ}\text{C}$ for Industrial $-40^{\circ}\text{C} \leq T_A \leq +125^{\circ}\text{C}$ for Extended				
Param.	Symbol	Characteristic ⁽¹⁾	Min.	Typ. ⁽²⁾	Max.	Units	Conditions
SP70	FscP	Maximum SCKx Input Frequency	—	—	11	MHz	(Note 3)
SP72	TscF	SCKx Input Fall Time	—	—	—	ns	See Parameter DO32 (Note 4)
SP73	TscR	SCKx Input Rise Time	—	—	—	ns	See Parameter DO31 (Note 4)
SP30	TdoF	SDOx Data Output Fall Time	—	—	—	ns	See Parameter DO32 (Note 4)
SP31	TdoR	SDOx Data Output Rise Time	—	—	—	ns	See Parameter DO31 (Note 4)
SP35	Tsch2doV, TscL2doV	SDOx Data Output Valid after SCKx Edge	—	6	20	ns	
SP36	TdoV2scH, TdoV2scL	SDOx Data Output Setup to First SCKx Edge	30	—	—	ns	
SP40	TdiV2scH, TdiV2scL	Setup Time of SDIx Data Input to SCKx Edge	30	—	—	ns	
SP41	Tsch2diL, TscL2diL	Hold Time of SDIx Data Input to SCKx Edge	30	—	—	ns	
SP50	TssL2scH, TssL2scL	$\overline{SSx} \downarrow$ to SCKx \uparrow or SCKx \downarrow Input	120	—	—	ns	
SP51	TssH2doZ	$\overline{SSx} \uparrow$ to SDOx Output High-Impedance	10	—	50	ns	(Note 4)
SP52	Tsch2ssH TscL2ssH	$\overline{SSx} \uparrow$ after SCKx Edge	$1.5 T_{CY} + 40$	—	—	ns	(Note 4)
SP60	TssL2doV	SDOx Data Output Valid after \overline{SSx} Edge	—	—	50	ns	

Note 1: These parameters are characterized, but are not tested in manufacturing.

Note 2: Data in “Typical” column is at 3.3V, +25°C unless otherwise stated.

Note 3: The minimum clock period for SCKx is 91 ns. Therefore, the SCKx clock generated by the master must not violate this specification.

Note 4: Assumes 50 pF load on all SPIx pins.

FIGURE 33-21: SPI2 AND SPI3 SLAVE MODE (FULL-DUPLEX, CKE = 0, CKP = 1, SMP = 0) TIMING CHARACTERISTICS

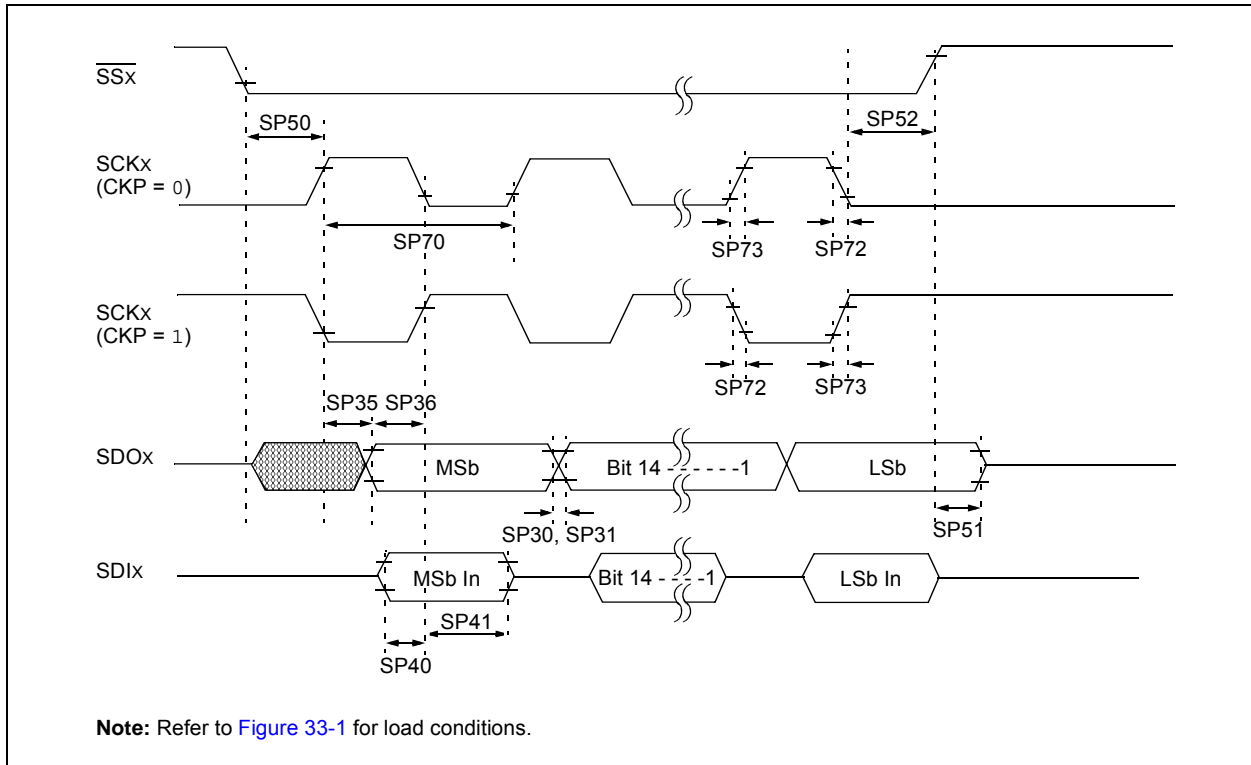

dsPIC33EPXXXGM3XX/6XX/7XX

**TABLE 33-38: SPI2 AND SPI3 SLAVE MODE (FULL-DUPLEX, CKE = 0, CKP = 1, SMP = 0)
TIMING REQUIREMENTS**

AC CHARACTERISTICS			Standard Operating Conditions: 3.0V to 3.6V (unless otherwise stated) Operating temperature $-40^{\circ}\text{C} \leq T_A \leq +85^{\circ}\text{C}$ for Industrial $-40^{\circ}\text{C} \leq T_A \leq +125^{\circ}\text{C}$ for Extended				
Param.	Symbol	Characteristic ⁽¹⁾	Min.	Typ. ⁽²⁾	Max.	Units	Conditions
SP70	FscP	Maximum SCKx Input Frequency	—	—	15	MHz	(Note 3)
SP72	TscF	SCKx Input Fall Time	—	—	—	ns	See Parameter DO32 (Note 4)
SP73	TscR	SCKx Input Rise Time	—	—	—	ns	See Parameter DO31 (Note 4)
SP30	TdoF	SDOx Data Output Fall Time	—	—	—	ns	See Parameter DO32 (Note 4)
SP31	TdoR	SDOx Data Output Rise Time	—	—	—	ns	See Parameter DO31 (Note 4)
SP35	Tsch2doV, TscL2doV	SDOx Data Output Valid after SCKx Edge	—	6	20	ns	
SP36	TdoV2scH, TdoV2scL	SDOx Data Output Setup to First SCKx Edge	30	—	—	ns	
SP40	TdiV2scH, TdiV2scL	Setup Time of SDIx Data Input to SCKx Edge	30	—	—	ns	
SP41	Tsch2diL, TscL2diL	Hold Time of SDIx Data Input to SCKx Edge	30	—	—	ns	
SP50	TssL2scH, TssL2scL	$\overline{\text{SS}}_x \downarrow$ to SCKx \uparrow or SCKx \downarrow Input	120	—	—	ns	
SP51	TssH2doZ	$\overline{\text{SS}}_x \uparrow$ to SDOx Output High-Impedance	10	—	50	ns	(Note 4)
SP52	Tsch2ssH TscL2ssH	$\overline{\text{SS}}_x \uparrow$ after SCKx Edge	$1.5 T_{CY} + 40$	—	—	ns	(Note 4)

- Note 1:** These parameters are characterized, but are not tested in manufacturing.
Note 2: Data in “Typical” column is at 3.3V, +25°C unless otherwise stated.
Note 3: The minimum clock period for SCKx is 66.7 ns. Therefore, the SCKx clock generated by the master must not violate this specification.
Note 4: Assumes 50 pF load on all SPIx pins.

FIGURE 33-22: SPI2 AND SPI3 SLAVE MODE (FULL-DUPLEX, CKE = 0, CKP = 0, SMP = 0) TIMING CHARACTERISTICS

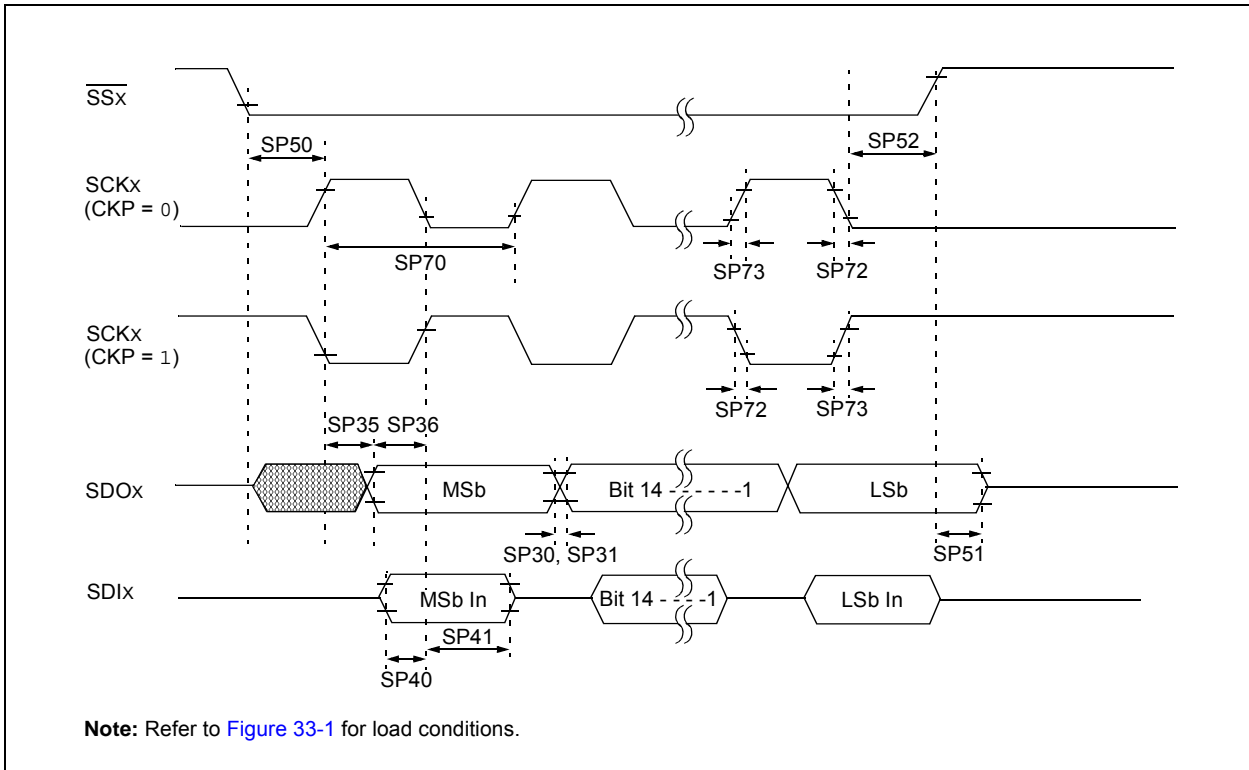

dsPIC33EPXXXGM3XX/6XX/7XX

**TABLE 33-39: SPI2 AND SPI3 SLAVE MODE (FULL-DUPLEX, CKE = 0, CKP = 0, SMP = 0)
TIMING REQUIREMENTS**

AC CHARACTERISTICS			Standard Operating Conditions: 3.0V to 3.6V (unless otherwise stated) Operating temperature $-40^{\circ}\text{C} \leq T_A \leq +85^{\circ}\text{C}$ for Industrial $-40^{\circ}\text{C} \leq T_A \leq +125^{\circ}\text{C}$ for Extended				
Param.	Symbol	Characteristic ⁽¹⁾	Min.	Typ. ⁽²⁾	Max.	Units	Conditions
SP70	FscP	Maximum SCKx Input Frequency	—	—	11	MHz	(Note 3)
SP72	TscF	SCKx Input Fall Time	—	—	—	ns	See Parameter DO32 (Note 4)
SP73	TscR	SCKx Input Rise Time	—	—	—	ns	See Parameter DO31 (Note 4)
SP30	TdoF	SDOx Data Output Fall Time	—	—	—	ns	See Parameter DO32 (Note 4)
SP31	TdoR	SDOx Data Output Rise Time	—	—	—	ns	See Parameter DO31 (Note 4)
SP35	Tsch2doV, TscL2doV	SDOx Data Output Valid after SCKx Edge	—	6	20	ns	
SP36	TdoV2scH, TdoV2scL	SDOx Data Output Setup to First SCKx Edge	30	—	—	ns	
SP40	TdiV2scH, TdiV2scL	Setup Time of SDIx Data Input to SCKx Edge	30	—	—	ns	
SP41	Tsch2diL, TscL2diL	Hold Time of SDIx Data Input to SCKx Edge	30	—	—	ns	
SP50	TssL2scH, TssL2scL	$\overline{\text{SS}}_x \downarrow$ to SCKx \uparrow or SCKx \downarrow Input	120	—	—	ns	
SP51	TssH2doZ	$\overline{\text{SS}}_x \uparrow$ to SDOx Output High-Impedance	10	—	50	ns	(Note 4)
SP52	Tsch2ssH TscL2ssH	$\overline{\text{SS}}_x \uparrow$ after SCKx Edge	$1.5 T_{CY} + 40$	—	—	ns	(Note 4)

- Note 1:** These parameters are characterized, but are not tested in manufacturing.
Note 2: Data in “Typical” column is at 3.3V, +25°C unless otherwise stated.
Note 3: The minimum clock period for SCKx is 91 ns. Therefore, the SCKx clock generated by the master must not violate this specification.
Note 4: Assumes 50 pF load on all SPIx pins.

TABLE 33-40: SPI1 MAXIMUM DATA/CLOCK RATE SUMMARY

AC CHARACTERISTICS			Standard Operating Conditions: 3.0V to 3.6V (unless otherwise stated) Operating temperature -40°C ≤ TA ≤ +85°C for Industrial -40°C ≤ TA ≤ +125°C for Extended			
Maximum Data Rate	Master Transmit Only (Half-Duplex)	Master Transmit/Receive (Full-Duplex)	Slave Transmit/Receive (Full-Duplex)	CKE	CKP	SMP
25 MHz	Table 33-41	—	—	0,1	0,1	0,1
25 MHz	—	Table 33-42	—	1	0,1	1
25 MHz	—	Table 33-43	—	0	0,1	1
25 MHz	—	—	Table 33-44	1	0	0
25 MHz	—	—	Table 33-45	1	1	0
25 MHz	—	—	Table 33-46	0	1	0
25 MHz	—	—	Table 33-47	0	0	0

FIGURE 33-23: SPI1 MASTER MODE (HALF-DUPLEX, TRANSMIT ONLY, CKE = 0) TIMING CHARACTERISTICS

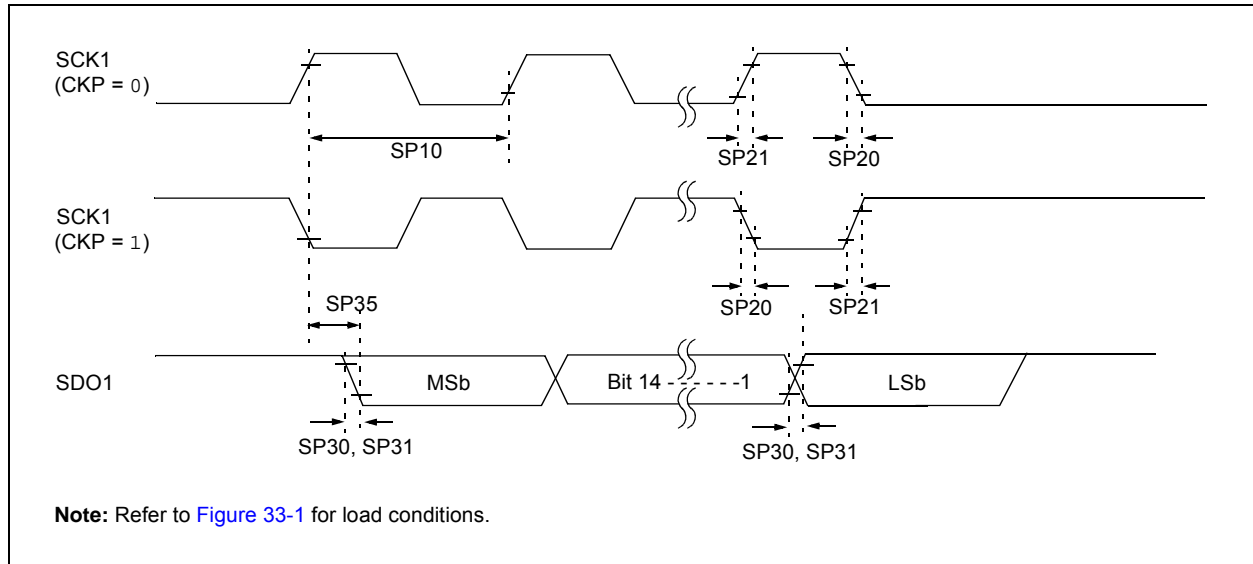

dsPIC33EPXXXGM3XX/6XX/7XX

FIGURE 33-24: SPI1 MASTER MODE (HALF-DUPLEX, TRANSMIT ONLY, CKE = 1) TIMING CHARACTERISTICS

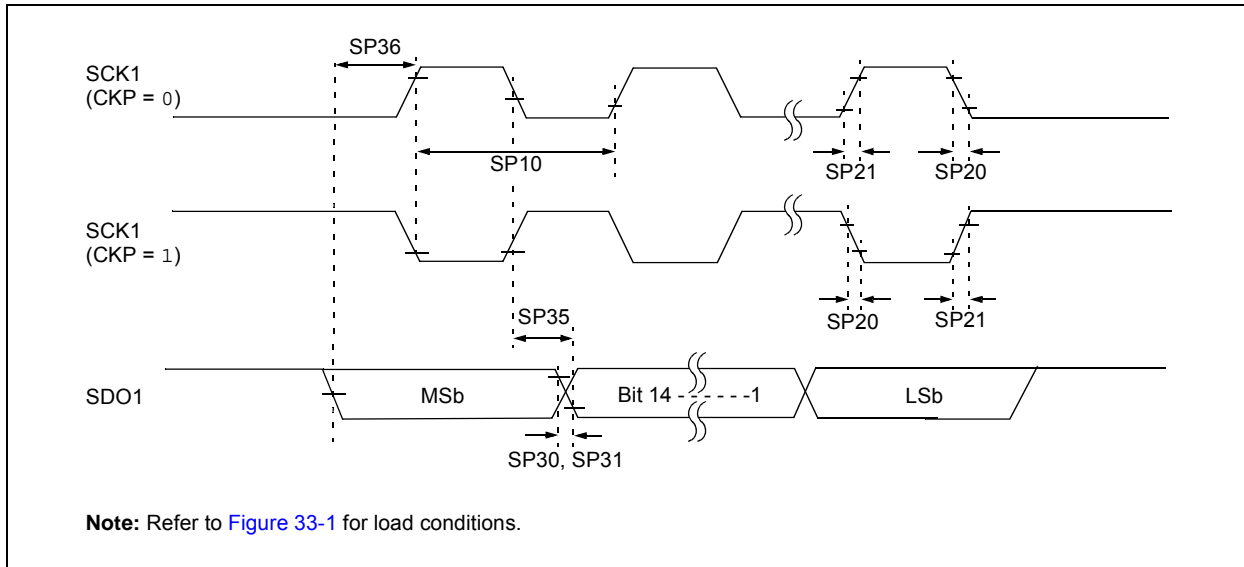

TABLE 33-41: SPI1 MASTER MODE (HALF-DUPLEX, TRANSMIT ONLY) TIMING REQUIREMENTS

AC CHARACTERISTICS			Standard Operating Conditions: 3.0V to 3.6V (unless otherwise stated) Operating temperature $-40^{\circ}\text{C} \leq T_A \leq +85^{\circ}\text{C}$ for Industrial $-40^{\circ}\text{C} \leq T_A \leq +125^{\circ}\text{C}$ for Extended				
Param.	Symbol	Characteristic ⁽¹⁾	Min.	Typ. ⁽²⁾	Max.	Units	Conditions
SP10	FscP	Maximum SCK1 Frequency	—	—	25	MHz	(Note 3)
SP20	TscF	SCK1 Output Fall Time	—	—	—	ns	See Parameter DO32 (Note 4)
SP21	TscR	SCK1 Output Rise Time	—	—	—	ns	See Parameter DO31 (Note 4)
SP30	TdoF	SDO1 Data Output Fall Time	—	—	—	ns	See Parameter DO32 (Note 4)
SP31	TdoR	SDO1 Data Output Rise Time	—	—	—	ns	See Parameter DO31 (Note 4)
SP35	Tsch2doV, TscL2doV	SDO1 Data Output Valid after SCK1 Edge	—	6	20	ns	
SP36	TdiV2scH, TdiV2scL	SDO1 Data Output Setup to First SCK1 Edge	20	—	—	ns	

Note 1: These parameters are characterized, but are not tested in manufacturing.

Note 2: Data in "Typical" column is at 3.3V, +25°C unless otherwise stated.

Note 3: The minimum clock period for SCK1 is 66.7 ns. Therefore, the clock generated in Master mode must not violate this specification.

Note 4: Assumes 50 pF load on all SPI1 pins.

FIGURE 33-25: SPI1 MASTER MODE (FULL-DUPLEX, CKE = 1, CKP = x, SMP = 1) TIMING CHARACTERISTICS

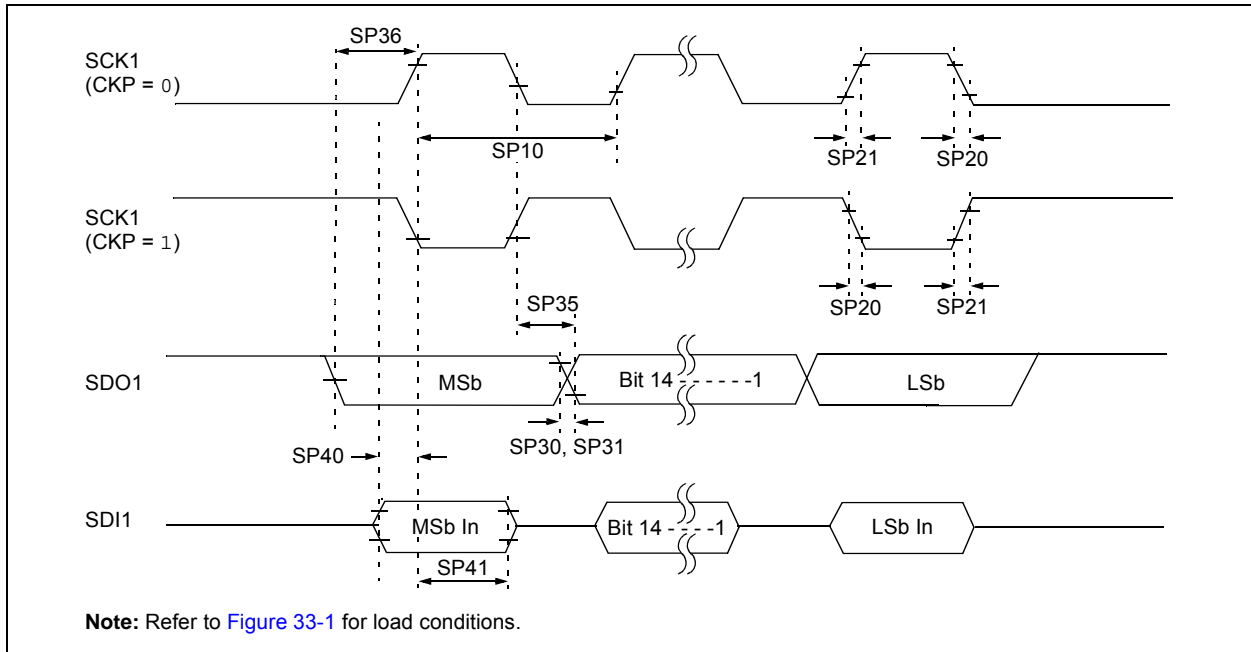

TABLE 33-42: SPI1 MASTER MODE (FULL-DUPLEX, CKE = 1, CKP = x, SMP = 1) TIMING REQUIREMENTS

AC CHARACTERISTICS			Standard Operating Conditions: 3.0V to 3.6V (unless otherwise stated) Operating temperature -40°C ≤ TA ≤ +85°C for Industrial -40°C ≤ TA ≤ +125°C for Extended				
Param.	Symbol	Characteristic ⁽¹⁾	Min.	Typ. ⁽²⁾	Max.	Units	Conditions
SP10	FscP	Maximum SCK1 Frequency	—	—	25	MHz	(Note 3)
SP20	TscF	SCK1 Output Fall Time	—	—	—	ns	See Parameter DO32 (Note 4)
SP21	TscR	SCK1 Output Rise Time	—	—	—	ns	See Parameter DO31 (Note 4)
SP30	TdoF	SDO1 Data Output Fall Time	—	—	—	ns	See Parameter DO32 (Note 4)
SP31	TdoR	SDO1 Data Output Rise Time	—	—	—	ns	See Parameter DO31 (Note 4)
SP35	Tsch2doV, TscL2doV	SDO1 Data Output Valid after SCK1 Edge	—	6	20	ns	
SP36	TdoV2sc, TdoV2scL	SDO1 Data Output Setup to First SCK1 Edge	20	—	—	ns	
SP40	TdiV2sch, TdiV2scL	Setup Time of SDI1 Data Input to SCK1 Edge	20	—	—	ns	
SP41	Tsch2diL, TscL2diL	Hold Time of SDI1 Data Input to SCK1 Edge	15	—	—	ns	

- Note 1:** These parameters are characterized, but are not tested in manufacturing.
Note 2: Data in “Typical” column is at 3.3V, +25°C unless otherwise stated.
Note 3: The minimum clock period for SCK1 is 100 ns. The clock generated in Master mode must not violate this specification.
Note 4: Assumes 50 pF load on all SPI1 pins.

dsPIC33EPXXXGM3XX/6XX/7XX

FIGURE 33-26: SPI1 MASTER MODE (FULL-DUPLEX, CKE = 0, CKP = x, SMP = 1) TIMING CHARACTERISTICS

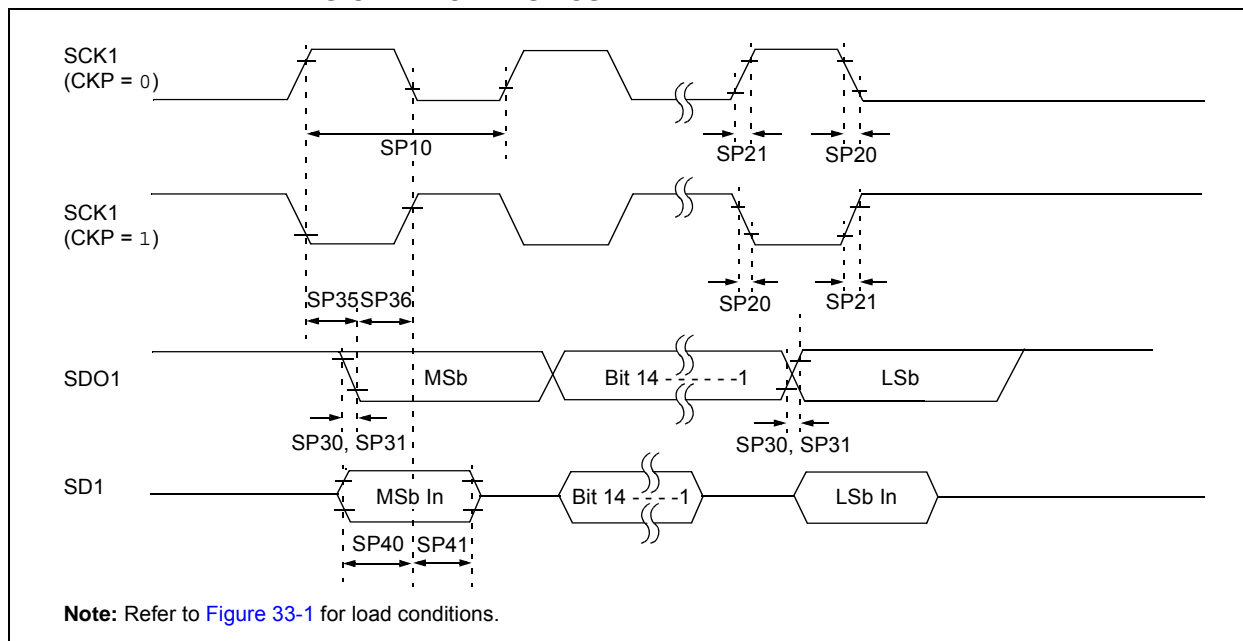

TABLE 33-43: SPI1 MASTER MODE (FULL-DUPLEX, CKE = 0, CKP = x, SMP = 1) TIMING REQUIREMENTS

AC CHARACTERISTICS			Standard Operating Conditions: 3.0V to 3.6V (unless otherwise stated) Operating temperature -40°C ≤ TA ≤ +85°C for Industrial -40°C ≤ TA ≤ +125°C for Extended				
Param.	Symbol	Characteristic ⁽¹⁾	Min.	Typ. ⁽²⁾	Max.	Units	Conditions
SP10	FscP	Maximum SCK1 Frequency	—	—	25	MHz	-40°C to +125°C (Note 3)
SP20	TscF	SCK1 Output Fall Time	—	—	—	ns	See Parameter DO32 (Note 4)
SP21	TscR	SCK1 Output Rise Time	—	—	—	ns	See Parameter DO31 (Note 4)
SP30	TdoF	SDO1 Data Output Fall Time	—	—	—	ns	See Parameter DO32 (Note 4)
SP31	TdoR	SDO1 Data Output Rise Time	—	—	—	ns	See Parameter DO31 (Note 4)
SP35	Tsch2doV, TscL2doV	SDO1 Data Output Valid after SCK1 Edge	—	6	20	ns	
SP36	TdoV2scH, TdoV2scL	SDO1 Data Output Setup to First SCK1 Edge	20	—	—	ns	
SP40	TdiV2scH, TdiV2scL	Setup Time of SDI1 Data Input to SCK1 Edge	20	—	—	ns	
SP41	Tsch2diL, TscL2diL	Hold Time of SDI1 Data Input to SCK1 Edge	20	—	—	ns	

Note 1: These parameters are characterized, but are not tested in manufacturing.

2: Data in "Typical" column is at 3.3V, +25°C unless otherwise stated.

3: The minimum clock period for SCK1 is 100 ns. The clock generated in Master mode must not violate this specification.

4: Assumes 50 pF load on all SPI1 pins.

**FIGURE 33-27: SPI1 SLAVE MODE (FULL-DUPLEX, CKE = 1, CKP = 0, SMP = 0)
TIMING CHARACTERISTICS**

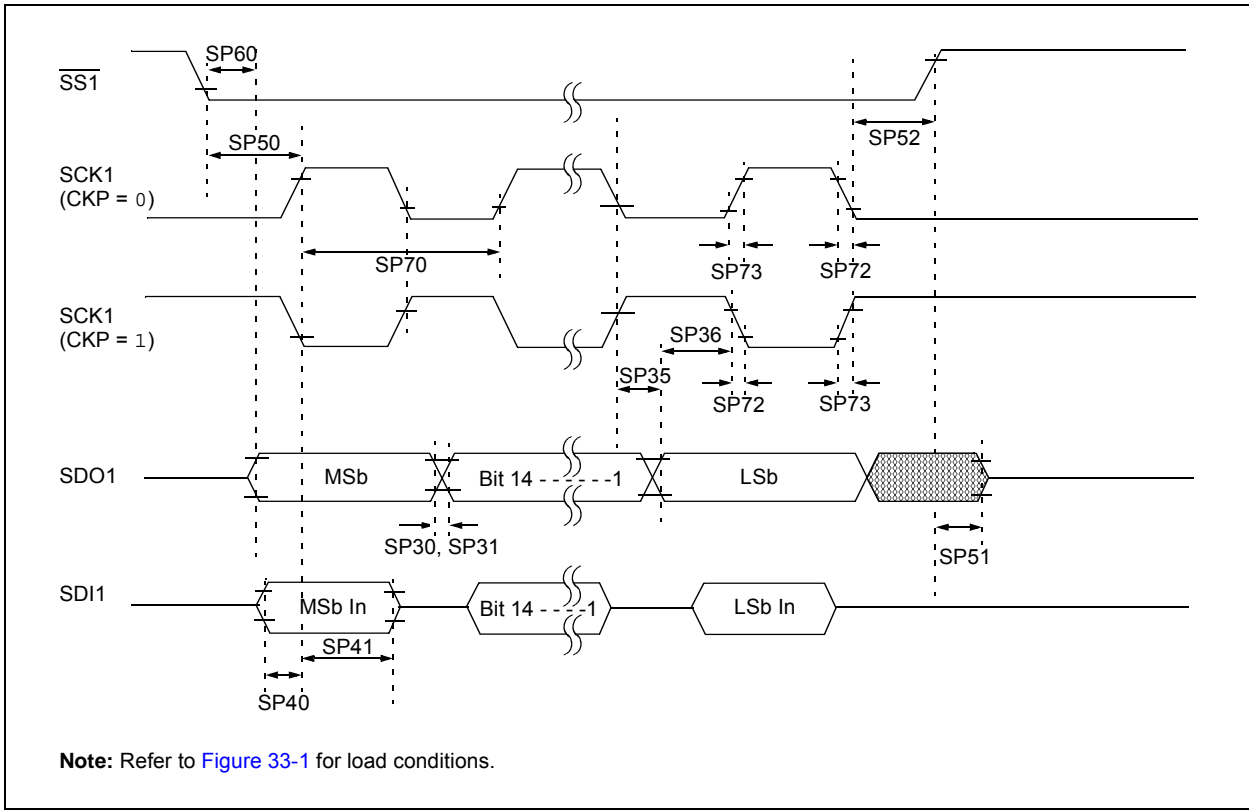

dsPIC33EPXXXGM3XX/6XX/7XX

**TABLE 33-44: SPI1 SLAVE MODE (FULL-DUPLEX, CKE = 1, CKP = 0, SMP = 0)
TIMING REQUIREMENTS**

AC CHARACTERISTICS			Standard Operating Conditions: 3.0V to 3.6V (unless otherwise stated) Operating temperature $-40^{\circ}\text{C} \leq T_A \leq +85^{\circ}\text{C}$ for Industrial $-40^{\circ}\text{C} \leq T_A \leq +125^{\circ}\text{C}$ for Extended				
Param.	Symbol	Characteristic ⁽¹⁾	Min.	Typ. ⁽²⁾	Max.	Units	Conditions
SP70	FscP	Maximum SCK1 Input Frequency	—	—	25	MHz	(Note 3)
SP72	TscF	SCK1 Input Fall Time	—	—	—	ns	See Parameter DO32 (Note 4)
SP73	TscR	SCK1 Input Rise Time	—	—	—	ns	See Parameter DO31 (Note 4)
SP30	TdoF	SDO1 Data Output Fall Time	—	—	—	ns	See Parameter DO32 (Note 4)
SP31	TdoR	SDO1 Data Output Rise Time	—	—	—	ns	See Parameter DO31 (Note 4)
SP35	Tsch2doV, TscL2doV	SDO1 Data Output Valid after SCK1 Edge	—	6	20	ns	
SP36	TdoV2scH, TdoV2scL	SDO1 Data Output Setup to First SCK1 Edge	20	—	—	ns	
SP40	TdiV2scH, TdiV2scL	Setup Time of SDIx Data Input to SCK1 Edge	20	—	—	ns	
SP41	Tsch2diL, TscL2diL	Hold Time of SDI1 Data Input to SCK1 Edge	15	—	—	ns	
SP50	TssL2scH, TssL2scL	$\overline{SS1} \downarrow$ to SCK1 \uparrow or SCK1 \downarrow Input	120	—	—	ns	
SP51	TssH2doZ	$\overline{SS1} \uparrow$ to SDO1 Output High-Impedance	10	—	50	ns	(Note 4)
SP52	Tsch2ssH TscL2ssH	$\overline{SS1} \uparrow$ after SCK1 Edge	$1.5 T_{CY} + 40$	—	—	ns	(Note 4)
SP60	TssL2doV	SDO1 Data Output Valid after $\overline{SS1}$ Edge	—	—	50	ns	

Note 1: These parameters are characterized, but are not tested in manufacturing.

2: Data in “Typical” column is at 3.3V, +25°C unless otherwise stated.

3: The minimum clock period for SCK1 is 66.7 ns. Therefore, the SCK1 clock generated by the master must not violate this specification.

4: Assumes 50 pF load on all SPI1 pins.

**FIGURE 33-28: SPI1 SLAVE MODE (FULL-DUPLEX, CKE = 1, CKP = 1, SMP = 0)
TIMING CHARACTERISTICS**

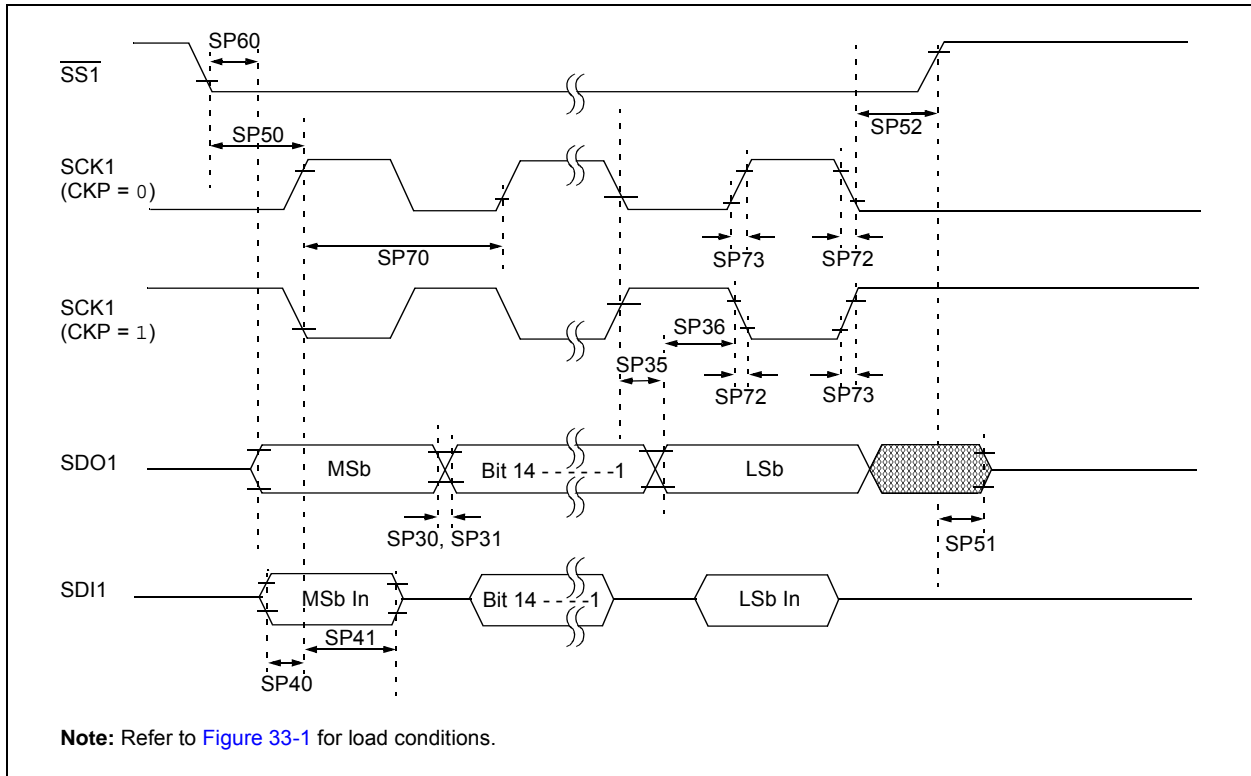

dsPIC33EPXXXGM3XX/6XX/7XX

**TABLE 33-45: SPI1 SLAVE MODE (FULL-DUPLEX, CKE = 1, CKP = 1, SMP = 0)
TIMING REQUIREMENTS**

AC CHARACTERISTICS			Standard Operating Conditions: 3.0V to 3.6V (unless otherwise stated) Operating temperature $-40^{\circ}\text{C} \leq T_A \leq +85^{\circ}\text{C}$ for Industrial $-40^{\circ}\text{C} \leq T_A \leq +125^{\circ}\text{C}$ for Extended				
Param.	Symbol	Characteristic ⁽¹⁾	Min.	Typ. ⁽²⁾	Max.	Units	Conditions
SP70	FscP	Maximum SCK1 Input Frequency	—	—	25	MHz	(Note 3)
SP72	TscF	SCK1 Input Fall Time	—	—	—	ns	See Parameter DO32 (Note 4)
SP73	TscR	SCK1 Input Rise Time	—	—	—	ns	See Parameter DO31 (Note 4)
SP30	TdoF	SDO1 Data Output Fall Time	—	—	—	ns	See Parameter DO32 (Note 4)
SP31	TdoR	SDO1 Data Output Rise Time	—	—	—	ns	See Parameter DO31 (Note 4)
SP35	Tsch2doV, TscL2doV	SDO1 Data Output Valid after SCK1 Edge	—	6	20	ns	
SP36	TdoV2scH, TdoV2scL	SDO1 Data Output Setup to First SCK1 Edge	20	—	—	ns	
SP40	TdiV2scH, TdiV2scL	Setup Time of SDI1 Data Input to SCK1 Edge	20	—	—	ns	
SP41	Tsch2diL, TscL2diL	Hold Time of SDI1 Data Input to SCK1 Edge	15	—	—	ns	
SP50	TssL2scH, TssL2scL	$\overline{SS1} \downarrow$ to SCK1 \uparrow or SCK1 \downarrow Input	120	—	—	ns	
SP51	TssH2doZ	$\overline{SS1} \uparrow$ to SDO1 Output High-Impedance	10	—	50	ns	(Note 4)
SP52	Tsch2ssH, TscL2ssH	$\overline{SS1} \uparrow$ after SCK1 Edge	$1.5 T_{CY} + 40$	—	—	ns	(Note 4)
SP60	TssL2doV	SDO1 Data Output Valid after $\overline{SS1}$ Edge	—	—	50	ns	

- Note 1:** These parameters are characterized, but are not tested in manufacturing.
Note 2: Data in “Typical” column is at 3.3V, +25°C unless otherwise stated.
Note 3: The minimum clock period for SCK1 is 91 ns. Therefore, the SCK1 clock generated by the master must not violate this specification.
Note 4: Assumes 50 pF load on all SPI1 pins.

**FIGURE 33-29: SPI1 SLAVE MODE (FULL-DUPLEX, CKE = 0, CKP = 1, SMP = 0)
TIMING CHARACTERISTICS**

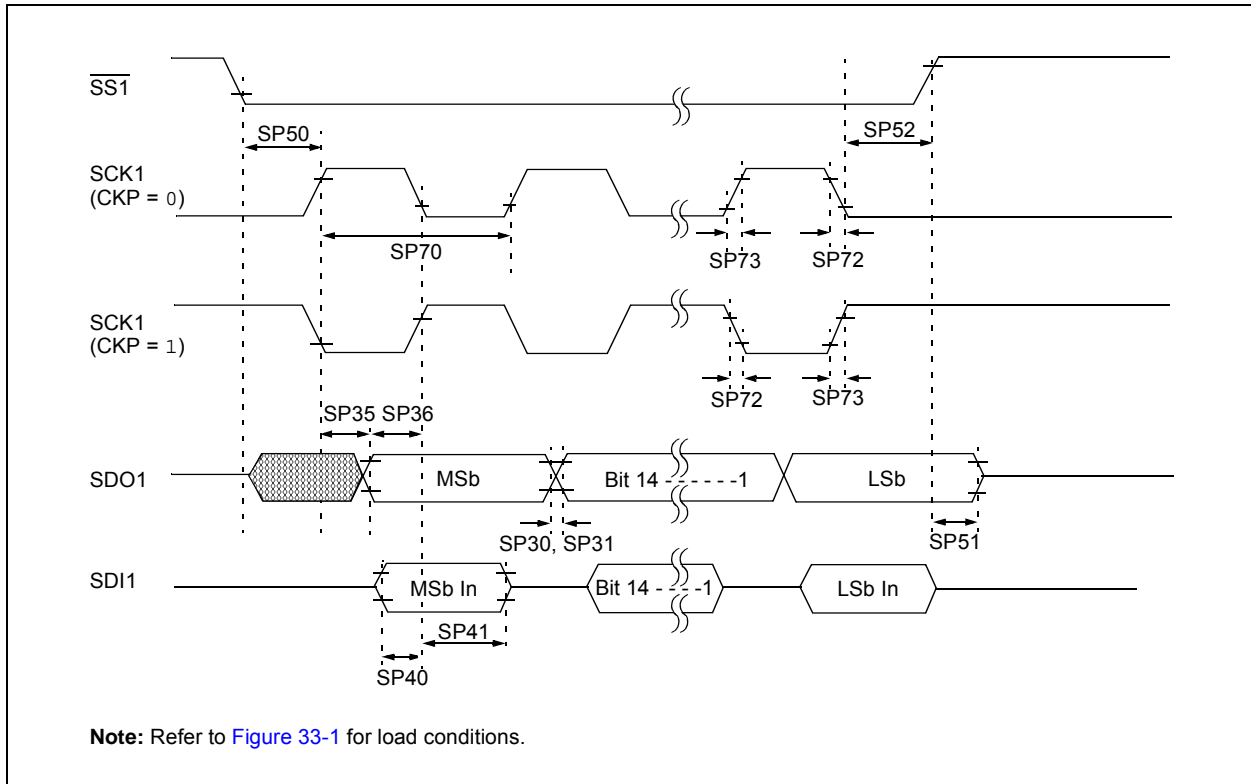

dsPIC33EPXXXGM3XX/6XX/7XX

**TABLE 33-46: SPI1 SLAVE MODE (FULL-DUPLEX, CKE = 0, CKP = 1, SMP = 0)
TIMING REQUIREMENTS**

AC CHARACTERISTICS			Standard Operating Conditions: 3.0V to 3.6V (unless otherwise stated) Operating temperature $-40^{\circ}\text{C} \leq T_A \leq +85^{\circ}\text{C}$ for Industrial $-40^{\circ}\text{C} \leq T_A \leq +125^{\circ}\text{C}$ for Extended				
Param.	Symbol	Characteristic ⁽¹⁾	Min.	Typ. ⁽²⁾	Max.	Units	Conditions
SP70	FscP	Maximum SCK1 Input Frequency	—	—	25	MHz	(Note 3)
SP72	TscF	SCK1 Input Fall Time	—	—	—	ns	See Parameter DO32 (Note 4)
SP73	TscR	SCK1 Input Rise Time	—	—	—	ns	See Parameter DO31 (Note 4)
SP30	TdoF	SDO1 Data Output Fall Time	—	—	—	ns	See Parameter DO32 (Note 4)
SP31	TdoR	SDO1 Data Output Rise Time	—	—	—	ns	See Parameter DO31 (Note 4)
SP35	Tsch2doV, TscL2doV	SDO1 Data Output Valid after SCK1 Edge	—	6	20	ns	
SP36	TdoV2scH, TdoV2scL	SDO1 Data Output Setup to First SCK1 Edge	20	—	—	ns	
SP40	TdiV2scH, TdiV2scL	Setup Time of SDI1 Data Input to SCK1 Edge	20	—	—	ns	
SP41	Tsch2diL, TscL2diL	Hold Time of SDI1 Data Input to SCK1 Edge	15	—	—	ns	
SP50	TssL2scH, TssL2scL	$\overline{\text{SS}}1 \downarrow$ to SCK1 \uparrow or SCK1 \downarrow Input	120	—	—	ns	
SP51	TssH2doZ	$\overline{\text{SS}}1 \uparrow$ to SDO1 Output High-Impedance	10	—	50	ns	(Note 4)
SP52	Tsch2ssH, TscL2ssH	$\overline{\text{SS}}1 \uparrow$ after SCK1 Edge	$1.5 T_{CY} + 40$	—	—	ns	(Note 4)

Note 1: These parameters are characterized, but are not tested in manufacturing.

Note 2: Data in “Typical” column is at 3.3V, +25°C unless otherwise stated.

Note 3: The minimum clock period for SCK1 is 66.7 ns. Therefore, the SCK1 clock generated by the master must not violate this specification.

Note 4: Assumes 50 pF load on all SPI1 pins.

**FIGURE 33-30: SPI1 SLAVE MODE (FULL-DUPLEX, CKE = 0, CKP = 0, SMP = 0)
TIMING CHARACTERISTICS**

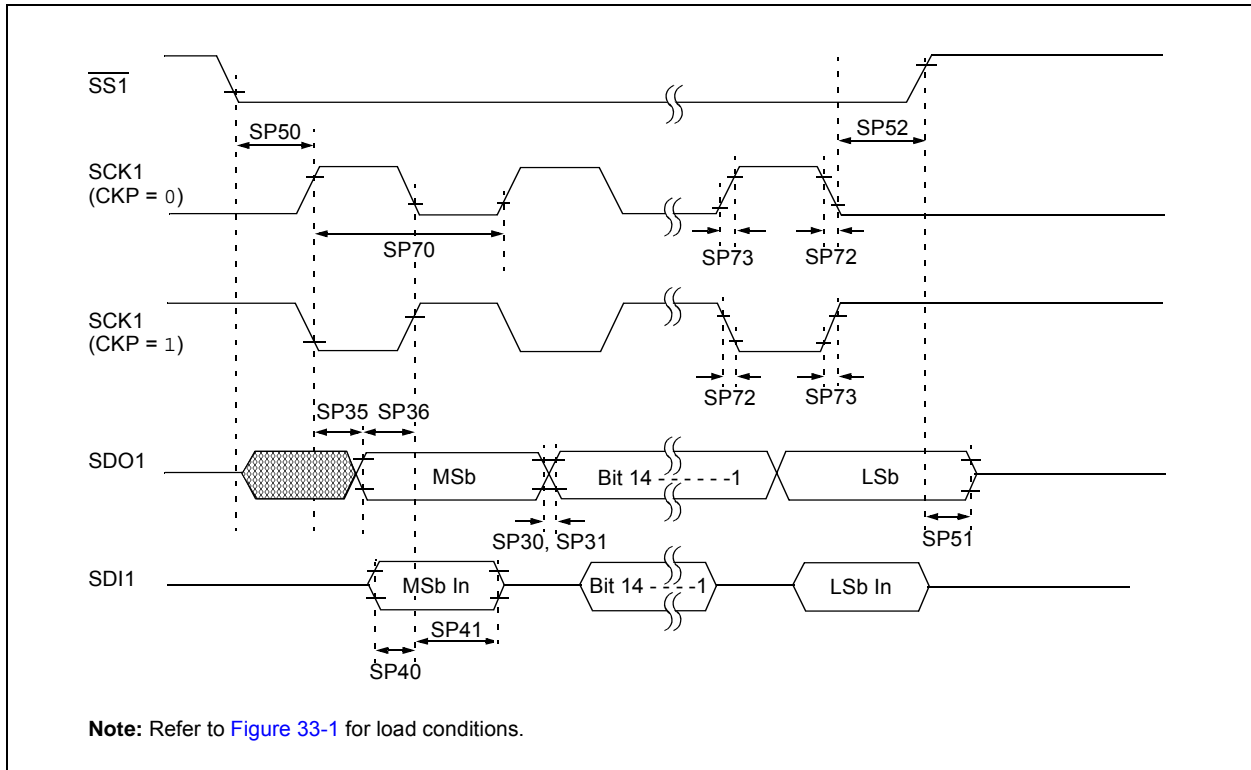

dsPIC33EPXXXGM3XX/6XX/7XX

**TABLE 33-47: SPI1 SLAVE MODE (FULL-DUPLEX, CKE = 0, CKP = 0, SMP = 0)
TIMING REQUIREMENTS**

AC CHARACTERISTICS			Standard Operating Conditions: 3.0V to 3.6V (unless otherwise stated) Operating temperature -40°C ≤ TA ≤ +85°C for Industrial -40°C ≤ TA ≤ +125°C for Extended				
Param.	Symbol	Characteristic ⁽¹⁾	Min.	Typ. ⁽²⁾	Max.	Units	Conditions
SP70	FscP	Maximum SCK1 Input Frequency	—	—	25	MHz	(Note 3)
SP72	TscF	SCK1 Input Fall Time	—	—	—	ns	See Parameter DO32 (Note 4)
SP73	TscR	SCK1 Input Rise Time	—	—	—	ns	See Parameter DO31 (Note 4)
SP30	TdoF	SDO1 Data Output Fall Time	—	—	—	ns	See Parameter DO32 (Note 4)
SP31	TdoR	SDO1 Data Output Rise Time	—	—	—	ns	See Parameter DO31 (Note 4)
SP35	Tsch2doV, TscL2doV	SDO1 Data Output Valid after SCK1 Edge	—	6	20	ns	
SP36	TdoV2scH, TdoV2scL	SDO1 Data Output Setup to First SCK1 Edge	20	—	—	ns	
SP40	TdiV2scH, TdiV2scL	Setup Time of SDI1 Data Input to SCK1 Edge	20	—	—	ns	
SP41	Tsch2diL, TscL2diL	Hold Time of SDI1 Data Input to SCK1 Edge	15	—	—	ns	
SP50	TssL2scH, TssL2scL	$\overline{SS1} \downarrow$ to SCK1 \uparrow or SCK1 \downarrow Input	120	—	—	ns	
SP51	TssH2doZ	$\overline{SS1} \uparrow$ to SDO1 Output High-Impedance	10	—	50	ns	(Note 4)
SP52	Tsch2ssH, TscL2ssH	$\overline{SS1} \uparrow$ after SCK1 Edge	1.5 T _{CY} + 40	—	—	ns	(Note 4)

- Note 1:** These parameters are characterized, but are not tested in manufacturing.
Note 2: Data in “Typical” column is at 3.3V, +25°C unless otherwise stated.
Note 3: The minimum clock period for SCK1 is 91 ns. Therefore, the SCK1 clock generated by the master must not violate this specification.
Note 4: Assumes 50 pF load on all SPI1 pins.

FIGURE 33-31: I2Cx BUS START/STOP BITS TIMING CHARACTERISTICS (MASTER MODE)

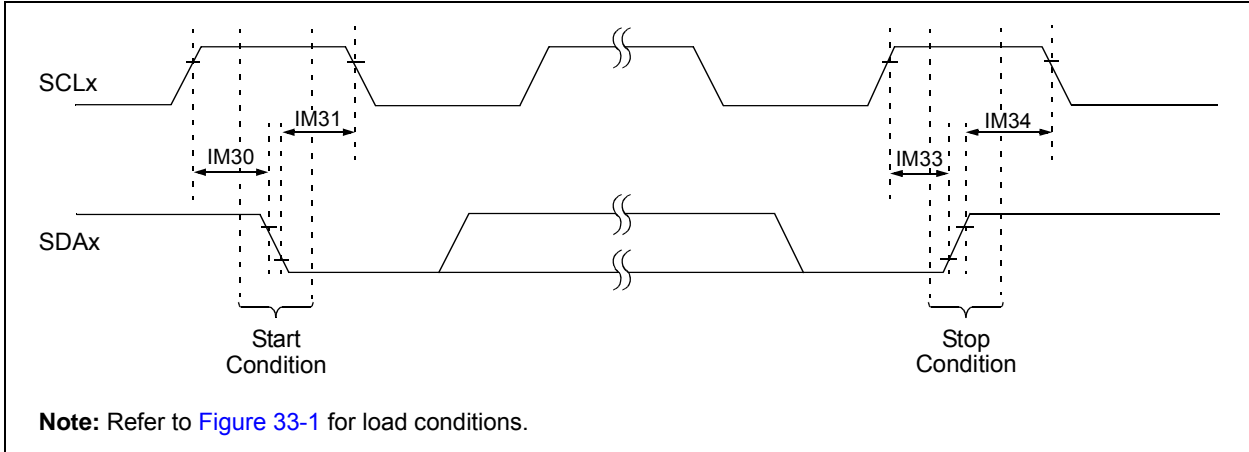
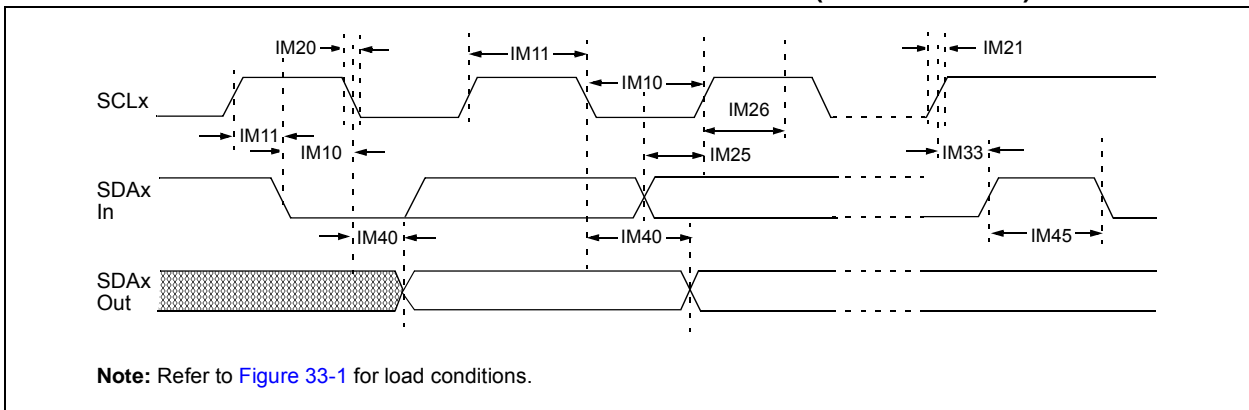

FIGURE 33-32: I2Cx BUS DATA TIMING CHARACTERISTICS (MASTER MODE)



dsPIC33EPXXXGM3XX/6XX/7XX

TABLE 33-48: I2Cx BUS DATA TIMING REQUIREMENTS (MASTER MODE)

AC CHARACTERISTICS				Standard Operating Conditions: 3.0V to 3.6V (unless otherwise stated) Operating temperature -40°C ≤ TA ≤ +85°C for Industrial -40°C ≤ TA ≤ +125°C for Extended			
Param No.	Symbol	Characteristic ⁽⁴⁾		Min. ⁽¹⁾	Max.	Units	Conditions
IM10	TLO:SCL	Clock Low Time	100 kHz mode	Tcy/2 (BRG + 2)	—	μs	
			400 kHz mode	Tcy/2 (BRG + 2)	—	μs	
			1 MHz mode ⁽²⁾	Tcy/2 (BRG + 2)	—	μs	
IM11	THI:SCL	Clock High Time	100 kHz mode	Tcy/2 (BRG + 2)	—	μs	
			400 kHz mode	Tcy/2 (BRG + 2)	—	μs	
			1 MHz mode ⁽²⁾	Tcy/2 (BRG + 2)	—	μs	
IM20	TF:SCL	SDAx and SCLx Fall Time	100 kHz mode	—	300	ns	Cb is specified to be from 10 to 400 pF
			400 kHz mode	20 + 0.1 Cb	300	ns	
			1 MHz mode ⁽²⁾	—	100	ns	
IM21	TR:SCL	SDAx and SCLx Rise Time	100 kHz mode	—	1000	ns	Cb is specified to be from 10 to 400 pF
			400 kHz mode	20 + 0.1 Cb	300	ns	
			1 MHz mode ⁽²⁾	—	300	ns	
IM25	TSU:DAT	Data Input Setup Time	100 kHz mode	250	—	ns	
			400 kHz mode	100	—	ns	
			1 MHz mode ⁽²⁾	40	—	ns	
IM26	THD:DAT	Data Input Hold Time	100 kHz mode	0	—	μs	
			400 kHz mode	0	0.9	μs	
			1 MHz mode ⁽²⁾	0.2	—	μs	
IM30	TSU:STA	Start Condition Setup Time	100 kHz mode	Tcy/2 (BRG + 2)	—	μs	Only relevant for Repeated Start condition
			400 kHz mode	Tcy/2 (BRG + 2)	—	μs	
			1 MHz mode ⁽²⁾	Tcy/2 (BRG + 2)	—	μs	
IM31	THD:STA	Start Condition Hold Time	100 kHz mode	Tcy/2 (BRG + 2)	—	μs	After this period, the first clock pulse is generated
			400 kHz mode	Tcy/2 (BRG + 2)	—	μs	
			1 MHz mode ⁽²⁾	Tcy/2 (BRG + 2)	—	μs	
IM33	TSU:STO	Stop Condition Setup Time	100 kHz mode	Tcy/2 (BRG + 2)	—	μs	
			400 kHz mode	Tcy/2 (BRG + 2)	—	μs	
			1 MHz mode ⁽²⁾	Tcy/2 (BRG + 2)	—	μs	
IM34	THD:STO	Stop Condition Hold Time	100 kHz mode	Tcy/2 (BRG + 2)	—	μs	
			400 kHz mode	Tcy/2 (BRG + 2)	—	μs	
			1 MHz mode ⁽²⁾	Tcy/2 (BRG + 2)	—	μs	
IM40	TAA:SCL	Output Valid From Clock	100 kHz mode	—	3500	ns	
			400 kHz mode	—	1000	ns	
			1 MHz mode ⁽²⁾	—	400	ns	
IM45	TBF:SDA	Bus Free Time	100 kHz mode	4.7	—	μs	Time the bus must be free before a new transmission can start
			400 kHz mode	1.3	—	μs	
			1 MHz mode ⁽²⁾	0.5	—	μs	
IM50	CB	Bus Capacitive Loading		—	400	pF	
IM51	TPGD	Pulse Gobbler Delay		65	390	ns	(Note 3)

Note 1: BRG is the value of the I²C Baud Rate Generator. Refer to the “dsPIC33/PIC24 Family Reference Manual”, “Inter-Integrated Circuit™ (I²C™)” (DS70000195). Please see the Microchip web site for the latest “dsPIC33E/PIC24E Family Reference Manual” sections.

2: Maximum pin capacitance = 10 pF for all I2Cx pins (for 1 MHz mode only).

3: Typical value for this parameter is 130 ns.

4: These parameters are characterized, but not tested in manufacturing.

FIGURE 33-33: I2Cx BUS START/STOP BITS TIMING CHARACTERISTICS (SLAVE MODE)

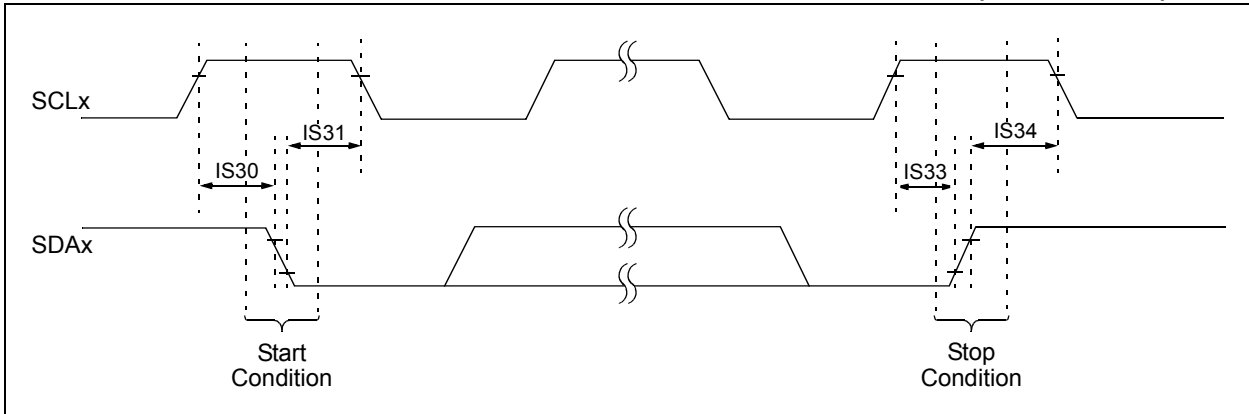
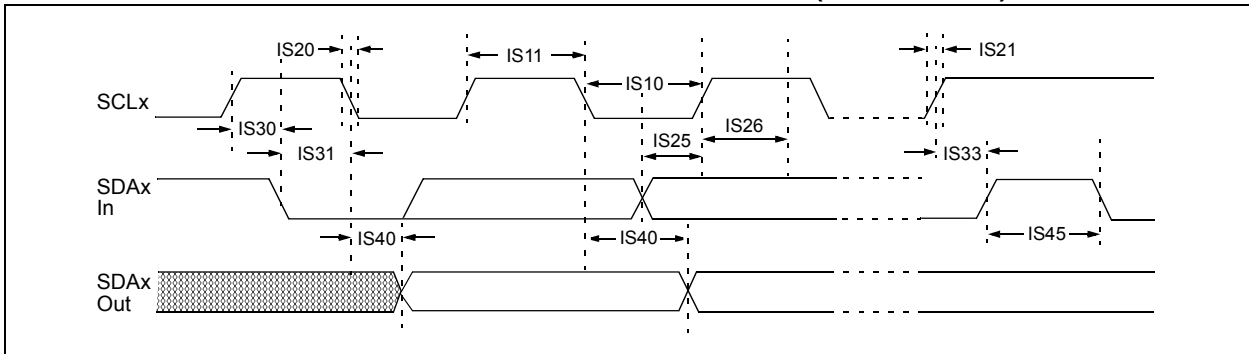

FIGURE 33-34: I2Cx BUS DATA TIMING CHARACTERISTICS (SLAVE MODE)



dsPIC33EPXXXGM3XX/6XX/7XX

TABLE 33-49: I2Cx BUS DATA TIMING REQUIREMENTS (SLAVE MODE)

AC CHARACTERISTICS				Standard Operating Conditions: 3.0V to 3.6V (unless otherwise stated) Operating temperature -40°C ≤ TA ≤ +85°C for Industrial -40°C ≤ TA ≤ +125°C for Extended			
Param. No.	Symbol	Characteristic ⁽³⁾		Min.	Max.	Units	Conditions
IS10	TLO:SCL	Clock Low Time	100 kHz mode	4.7	—	μs	
			400 kHz mode	1.3	—	μs	
			1 MHz mode ⁽¹⁾	0.5	—	μs	
IS11	THI:SCL	Clock High Time	100 kHz mode	4.0	—	μs	Device must operate at a minimum of 1.5 MHz
			400 kHz mode	0.6	—	μs	Device must operate at a minimum of 10 MHz
			1 MHz mode ⁽¹⁾	0.5	—	μs	
IS20	TF:SCL	SDAx and SCLx Fall Time	100 kHz mode	—	300	ns	CB is specified to be from 10 to 400 pF
			400 kHz mode	20 + 0.1 CB	300	ns	
			1 MHz mode ⁽¹⁾	—	100	ns	
IS21	TR:SCL	SDAx and SCLx Rise Time	100 kHz mode	—	1000	ns	CB is specified to be from 10 to 400 pF
			400 kHz mode	20 + 0.1 CB	300	ns	
			1 MHz mode ⁽¹⁾	—	300	ns	
IS25	TSU:DAT	Data Input Setup Time	100 kHz mode	250	—	ns	
			400 kHz mode	100	—	ns	
			1 MHz mode ⁽¹⁾	100	—	ns	
IS26	THD:DAT	Data Input Hold Time	100 kHz mode	0	—	μs	
			400 kHz mode	0	0.9	μs	
			1 MHz mode ⁽¹⁾	0	0.3	μs	
IS30	TSU:STA	Start Condition Setup Time	100 kHz mode	4.7	—	μs	Only relevant for Repeated Start condition
			400 kHz mode	0.6	—	μs	
			1 MHz mode ⁽¹⁾	0.25	—	μs	
IS31	THD:STA	Start Condition Hold Time	100 kHz mode	4.0	—	μs	After this period, the first clock pulse is generated
			400 kHz mode	0.6	—	μs	
			1 MHz mode ⁽¹⁾	0.25	—	μs	
IS33	TSU:STO	Stop Condition Setup Time	100 kHz mode	4.7	—	μs	
			400 kHz mode	0.6	—	μs	
			1 MHz mode ⁽¹⁾	0.6	—	μs	
IS34	THD:STO	Stop Condition Hold Time	100 kHz mode	4	—	μs	
			400 kHz mode	0.6	—	μs	
			1 MHz mode ⁽¹⁾	0.25	—	μs	
IS40	TAA:SCL	Output Valid From Clock	100 kHz mode	0	3500	ns	
			400 kHz mode	0	1000	ns	
			1 MHz mode ⁽¹⁾	0	350	ns	
IS45	TBF:SDA	Bus Free Time	100 kHz mode	4.7	—	μs	Time the bus must be free before a new transmission can start
			400 kHz mode	1.3	—	μs	
			1 MHz mode ⁽¹⁾	0.5	—	μs	
IS50	CB	Bus Capacitive Loading	—	400	pF		
IS51	TPGD	Pulse Gobbler Delay	65	390	ns	(Note 2)	

Note 1: Maximum pin capacitance = 10 pF for all I2Cx pins (for 1 MHz mode only).

2: The Typical value for this parameter is 130 ns.

3: These parameters are characterized, but not tested in manufacturing.

FIGURE 33-35: CANx MODULE I/O TIMING CHARACTERISTICS

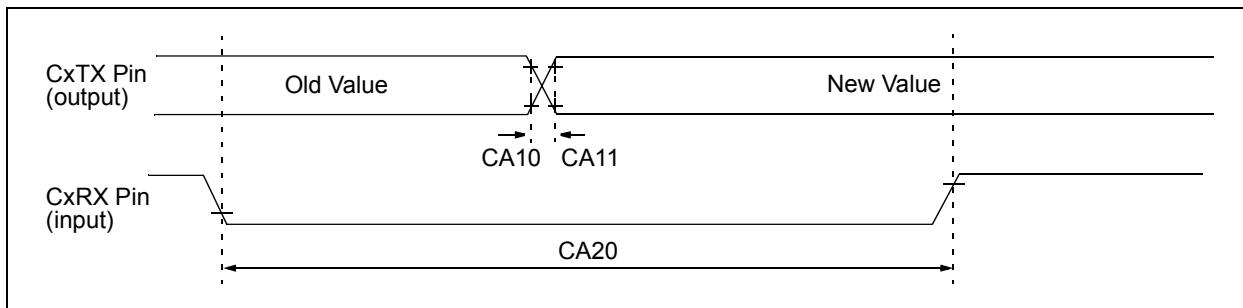

TABLE 33-50: CANx MODULE I/O TIMING REQUIREMENTS

AC CHARACTERISTICS			Standard Operating Conditions: 3.0V to 3.6V (unless otherwise stated) Operating temperature $-40^{\circ}\text{C} \leq T_A \leq +85^{\circ}\text{C}$ for Industrial $-40^{\circ}\text{C} \leq T_A \leq +125^{\circ}\text{C}$ for Extended				
Param No.	Symbol	Characteristic ⁽¹⁾	Min.	Typ. ⁽²⁾	Max.	Units	Conditions
CA10	TioF	Port Output Fall Time	—	—	—	ns	See Parameter DO32
CA11	TioR	Port Output Rise Time	—	—	—	ns	See Parameter DO31
CA20	TCWF	Pulse Width to Trigger CAN Wake-up Filter	120	—	—	ns	

Note 1: These parameters are characterized but not tested in manufacturing.

Note 2: Data in “Typical” column is at 3.3V, +25°C unless otherwise stated. Parameters are for design guidance only and are not tested.

FIGURE 33-36: UARTx MODULE I/O TIMING CHARACTERISTICS

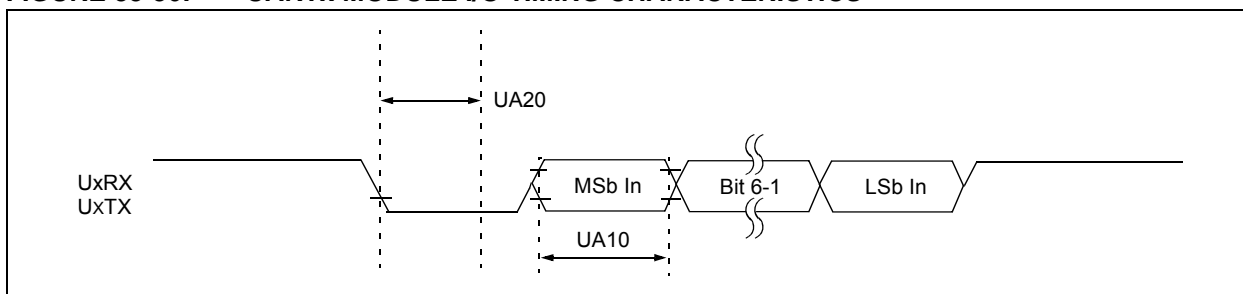

TABLE 33-51: UARTx MODULE I/O TIMING REQUIREMENTS

AC CHARACTERISTICS			Standard Operating Conditions: 3.0V to 3.6V (unless otherwise stated) Operating temperature $-40^{\circ}\text{C} \leq T_A \leq +125^{\circ}\text{C}$				
Param No.	Symbol	Characteristic ⁽¹⁾	Min.	Typ. ⁽²⁾	Max.	Units	Conditions
UA10	TUABAUD	UARTx Baud Time	66.67	—	—	ns	
UA11	FBAUD	UARTx Baud Frequency	—	—	15	Mbps	
UA20	TCWF	Start Bit Pulse Width to Trigger UARTx Wake-up	500	—	—	ns	

Note 1: These parameters are characterized but not tested in manufacturing.

Note 2: Data in “Typical” column is at 3.3V, +25°C unless otherwise stated. Parameters are for design guidance only and are not tested.

dsPIC33EPXXXGM3XX/6XX/7XX

TABLE 33-52: OP AMP/COMPARATOR SPECIFICATIONS

DC CHARACTERISTICS			Standard Operating Conditions (see Note 3): 3.0V to 3.6V (unless otherwise stated) Operating temperature -40°C ≤ TA ≤ +85°C for Industrial -40°C ≤ TA ≤ +125°C for Extended				
Param No.	Symbol	Characteristic	Min.	Typ. ⁽¹⁾	Max.	Units	Conditions
Comparator AC Characteristics							
CM10	TRESP	Response Time	—	19	—	ns	V+ input step of 100 mV, V- input held at VDD/2
CM11	TMC2OV	Comparator Mode Change to Output Valid	—	—	10	µs	
Comparator DC Characteristics							
CM30	VOFFSET	Comparator Offset Voltage	—	±20	±75	mV	
CM31	VHYST	Input Hysteresis Voltage	—	30	—	mV	
CM32	TRISE/ TFALL	Comparator Output Rise/Fall Time	—	20	—	ns	1 pF load capacitance on input
CM33	VGAIN	Open-Loop Voltage Gain	—	90	—	db	
CM34	VICM	Input Common-Mode Voltage	AVSS	—	AVDD	V	
Op Amp AC Characteristics							
CM20	SR	Slew Rate	—	9	—	V/µs	10 pF load
CM21a	PM	Phase Margin	—	68	—	Degree	G = 100V/V; 10 pF load
CM22	GM	Gain Margin	—	20	—	db	G = 100V/V; 10 pF load
CM23a	GBW	Gain Bandwidth	—	10	—	MHz	10 pF load
Op Amp DC Characteristics							
CM40	VCMR	Common-Mode Input Voltage Range	AVSS	—	AVDD	V	
CM41	CMRR	Common-Mode Rejection Ratio	—	40	—	db	VCM = AVDD/2
CM42	VOFFSET	Op Amp Offset Voltage	—	±20	±70	mV	
CM43	VGAIN	Open-Loop Voltage Gain	—	90	—	db	
CM44	IOS	Input Offset Current	—	—	—	—	See pad leakage currents in Table 33-10
CM45	IB	Input Bias Current	—	—	—	—	See pad leakage currents in Table 33-10
CM46	IOUT	Output Current	—	—	420	µA	With minimum value of RFEEDBACK (CM48)
CM48	RFEEDBACK	Feedback Resistance Value	8	—	—	kΩ	(Note 2)
CM49a	VOUT	Output Voltage	AVSS + 0.075	—	AVDD - 0.075	V	IOUT = 420 µA

Note 1: Data in “Typ” column is at 3.3V, +25°C unless otherwise stated.

2: Resistances can vary by ±10% between op amps.

3: Device is functional at VBORMIN < VDD < VDDMIN, but will have degraded performance. Device functionality is tested, but not characterized. Analog modules: ADC, op amp/comparator and comparator voltage reference, will have degraded performance. Refer to Parameter [BO10](#) in [Table 33-12](#) for the minimum and maximum BOR values.

TABLE 33-53: OP AMP/COMPARATOR VOLTAGE REFERENCE SETTling TIME SPECIFICATIONS

AC CHARACTERISTICS			Standard Operating Conditions (see Note 2): 3.0V to 3.6V (unless otherwise stated) Operating temperature -40°C ≤ TA ≤ +85°C for Industrial -40°C ≤ TA ≤ +125°C for Extended				
Param.	Symbol	Characteristic	Min.	Typ.	Max.	Units	Conditions
VR310	TSET	Settling Time	—	1	10	μs	(Note 1)

- Note 1:** Settling time is measured while CVRR = 1 and the CVR<3:0> bits transition from '0000' to '1111'.
- 2:** Device is functional at VBORMIN < VDD < VDDMIN, but will have degraded performance. Device functionality is tested, but not characterized. Analog modules: ADC, op amp/comparator and comparator voltage reference, will have degraded performance. Refer to Parameter BO10 in Table 33-12 for the minimum and maximum BOR values.

TABLE 33-54: OP AMP/COMPARATOR VOLTAGE REFERENCE SPECIFICATIONS

DC CHARACTERISTICS			Standard Operating Conditions (see Note 1): 3.0V to 3.6V (unless otherwise stated) Operating temperature -40°C ≤ TA ≤ +85°C for Industrial -40°C ≤ TA ≤ +125°C for Extended				
Param No.	Symbol	Characteristics	Min.	Typ.	Max.	Units	Conditions
VRD310	CVRES	Resolution	CVRSRC/24	—	CVRSRC/32	LSb	
VRD311	CVRAA	Absolute Accuracy of Internal DAC Input to Comparators	—	—	±25	mV	AVDD = CVRSRC = 3.3V
VRD312	CVRAA1	Absolute Accuracy of CVREFXO pins	—	—	+75/-25	mV	AVDD = CVRSRC = 3.3V
VRD313	CVRSRC	Input Reference Voltage	0	—	AVDD + 0.3	V	
VRD314	CVR0UT	Buffer Output Resistance	—	1.5k	—	Ω	
VRD315	CVCL	Permissible Capacitive Load (CVREFXO pins)	—	—	25	pF	
VRD316	IOCVR	Permissible Current Output (CVREFXO pins)	—	—	1	mA	
VRD317	ION	Current Consumed When Module is Enabled	—	—	500	μA	AVDD = 3.6V
VRD318	IOFF	Current Consumed When Module is Disabled	—	—	1	nA	AVDD = 3.6V

- Note 1:** Device is functional at VBORMIN < VDD < VDDMIN, but will have degraded performance. Device functionality is tested, but not characterized. Analog modules: ADC, op amp/comparator and comparator voltage reference, will have degraded performance. Refer to Parameter BO10 in Table 33-12 for the minimum and maximum BOR values.

dsPIC33EPXXXGM3XX/6XX/7XX

TABLE 33-55: CTMU CURRENT SOURCE SPECIFICATIONS

DC CHARACTERISTICS			Standard Operating Conditions: 3.0V to 3.6V (unless otherwise stated) Operating temperature $-40^{\circ}\text{C} \leq T_A \leq +85^{\circ}\text{C}$ for Industrial $-40^{\circ}\text{C} \leq T_A \leq +125^{\circ}\text{C}$ for Extended				
Param No.	Symbol	Characteristic ⁽¹⁾	Min.	Typ.	Max.	Units	Conditions
CTMU Current Source							
CTMUI1	IOUT1	Base Range	280	550	830	nA	CTMUICON<9:8> = 01
CTMUI2	IOUT2	10x Range	2.8	5.5	8.3	μA	CTMUICON<9:8> = 10
CTMUI3	IOUT3	100x Range	28	55	83	μA	CTMUICON<9:8> = 11
CTMUI4	IOUT4	1000x Range	280	550	830	μA	CTMUICON<9:8> = 00
CTMUFV1	V _F		—	0.77	—	V	
CTMUFV2	V _{FVR}		—	-1.38	—	mV/°C	

Note 1: Nominal value at center point of current trim range (CTMUICON<15:10> = 000000).

FIGURE 33-37: LOAD CONDITIONS FOR DEVICE TIMING SPECIFICATIONS

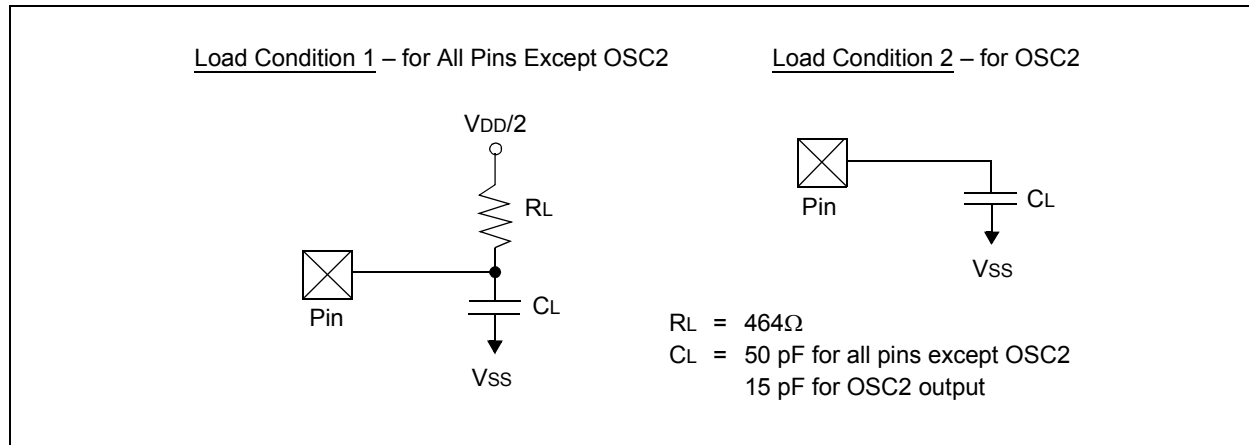

TABLE 33-56: ADCx MODULE SPECIFICATIONS

AC CHARACTERISTICS			Standard Operating Conditions (see Note 1): 3.0V to 3.6V (unless otherwise stated) Operating temperature $-40^{\circ}\text{C} \leq T_A \leq +85^{\circ}\text{C}$ for Industrial $-40^{\circ}\text{C} \leq T_A \leq +125^{\circ}\text{C}$ for Extended				
Param No.	Symbol	Characteristic	Min.	Typ.	Max.	Units	Conditions
Device Supply							
AD01	AVDD	Module VDD Supply	Greater of: VDD – 0.3 or 3.0	—	Lesser of: VDD + 0.3 or 3.6	V	
AD02	AVSS	Module VSS Supply	VSS – 0.3	—	VSS + 0.3	V	
Reference Inputs							
AD05	VREFH	Reference Voltage High	AVSS + 2.7	—	AVDD	V	(Note 1) VREFH = VREF+, VREFL = VREF-
AD05a			3.0	—	3.6	V	
AD06	VREFL	Reference Voltage Low	AVSS	—	AVDD – 2.7	V	(Note 1) VREFH = AVDD, VREFL = AVSS = 0
AD06a			0	—	0	V	
AD07	VREF	Absolute Reference Voltage	2.7	—	3.6	V	VREF = VREFH – VREFL
AD08	IREF	Current Drain	—	—	10 600	μA μA	ADC off ADC on
AD09	IAD	Operating Current	—	5 2	—	mA mA	ADC operating in 10-bit mode (Note 1) ADC operating in 12-bit mode (Note 1)
Analog Input							
AD12	VINH	Input Voltage Range, VINH	VINL	—	VREFH	V	This voltage reflects Sample-and-Hold Channels 0, 1, 2 and 3 (CH0-CH3), positive input
AD13	VINL	Input Voltage Range, VINL	VREFL	—	AVSS + 1V	V	This voltage reflects Sample-and-Hold Channels 0, 1, 2 and 3 (CH0-CH3), negative input
AD17	RIN	Recommended Impedance of Analog Voltage Source	—	—	200	Ω	Impedance to achieve maximum performance of ADC

Note 1: Device is functional at $V_{BORMIN} < V_{DD} < V_{DDMIN}$, but will have degraded performance. Device functionality is tested, but not characterized. Analog modules: ADC, op amp/comparator and comparator voltage reference, will have degraded performance. Refer to Parameter [BO10](#) in [Table 33-12](#) for the minimum and maximum BOR values.

dsPIC33EPXXXGM3XX/6XX/7XX

TABLE 33-57: ADCx MODULE SPECIFICATIONS (12-BIT MODE)

AC CHARACTERISTICS			Standard Operating Conditions (see Note 1): 3.0V to 3.6V (unless otherwise stated) Operating temperature -40°C ≤ TA ≤ +85°C for Industrial -40°C ≤ TA ≤ +125°C for Extended				
Param No.	Symbol	Characteristic	Min.	Typ.	Max.	Units	Conditions
ADC Accuracy (12-Bit Mode) – VREF-							
AD20a	Nr	Resolution	12 data bits			bits	
AD21a	INL	Integral Nonlinearity	-3	—	+3	LSb	VINL = AVSS = VREFL = 0V, AVDD = VREFH = 3.6V (Note 2)
AD22a	DNL	Differential Nonlinearity	≥ 1	—	< 1	LSb	VINL = AVSS = VREFL = 0V, AVDD = VREFH = 3.6V (Note 2)
AD23a	GERR	Gain Error	-10	—	10	LSb	VINL = AVSS = VREFL = 0V, AVDD = VREFH = 3.6V (Note 2)
AD24a	EOFF	Offset Error	-5	—	5	LSb	VINL = AVSS = VREFL = 0V, AVDD = VREFH = 3.6V (Note 2)
AD25a	—	Monotonicity	—	—	—	—	Guaranteed
Dynamic Performance (12-Bit Mode)							
AD30a	THD	Total Harmonic Distortion	—	—	-75	dB	
AD31a	SINAD	Signal to Noise and Distortion	68.5	69.5	—	dB	
AD32a	SFDR	Spurious Free Dynamic Range	80	—	—	dB	
AD33a	FNYQ	Input Signal Bandwidth	—	—	250	kHz	
AD34a	ENOB	Effective Number of Bits	11.09	11.3	—	bits	

Note 1: Device is functional at VBORMIN < VDD < VDDMIN, but will have degraded performance. Device functionality is tested, but not characterized. Analog modules: ADC, op amp/comparator and comparator voltage reference, will have degraded performance. Refer to Parameter BO10 in Table 33-12 for the minimum and maximum BOR values.

2: For all accuracy specifications, VINL = AVSS = VREFL = 0V and AVDD = VREFH = 3.6V.

TABLE 33-58: ADCx MODULE SPECIFICATIONS (10-BIT MODE)

AC CHARACTERISTICS			Standard Operating Conditions: 3.0V to 3.6V (unless otherwise stated) ⁽¹⁾ Operating temperature -40°C ≤ TA ≤ +85°C for Industrial -40°C ≤ TA ≤ +125°C for Extended				
Param No.	Symbol	Characteristic	Min.	Typ.	Max.	Units	Conditions
ADC Accuracy (10-Bit Mode)							
AD20b	Nr	Resolution	10 Data Bits			bits	
AD21b	INL	Integral Nonlinearity	-0.625	—	0.625	LSb	-40°C ≤ TA ≤ +85°C (Note 2)
			-1.5	—	1.5	LSb	+85°C < TA ≤ +125°C (Note 2)
AD22b	DNL	Differential Nonlinearity	-0.25	—	0.25	LSb	-40°C ≤ TA ≤ +85°C (Note 2)
			-0.25	—	0.25	LSb	+85°C < TA ≤ +125°C (Note 2)
AD23b	GERR	Gain Error	-2.5	—	2.5	LSb	-40°C ≤ TA ≤ +85°C (Note 2)
			-2.5	—	2.5	LSb	+85°C < TA ≤ +125°C (Note 2)
AD24b	EOFF	Offset Error	-1.25	—	1.25	LSb	-40°C ≤ TA ≤ +85°C (Note 2)
			-1.25	—	1.25	LSb	+85°C < TA ≤ +125°C (Note 2)
AD25b	—	Monotonicity	—	—	—	—	Guaranteed
Dynamic Performance (10-Bit Mode)							
AD30b	THD	Total Harmonic Distortion ⁽³⁾	—	64	—	dB	
AD31b	SINAD	Signal to Noise and Distortion ⁽³⁾	—	57	—	dB	
AD32b	SFDR	Spurious Free Dynamic Range ⁽³⁾	—	72	—	dB	
AD33b	FNYQ	Input Signal Bandwidth ⁽³⁾	—	550	—	kHz	
AD34b	ENOB	Effective Number of Bits ⁽³⁾	—	9.4	—	bits	

Note 1: Device is functional at VBORMIN < VDD < VDDMIN, but will have degraded performance. Device functionality is tested, but not characterized. Analog modules: ADC, op amp/comparator and comparator voltage reference, may have degraded performance. Refer to Parameter [BO10](#) in [Table 33-12](#) for the minimum and maximum BOR values.

2: For all accuracy specifications, VINL = AVSS = VREFL = 0V and AVDD = VREFH = 3.6V.

3: Parameters are characterized but not tested in manufacturing.

dsPIC33EPXXGM3XX/6XX/7XX

FIGURE 33-38: ADC1 CONVERSION (12-BIT MODE) TIMING CHARACTERISTICS
(ASAM = 0, SSRC<2:0> = 000, SSRCG = 0)

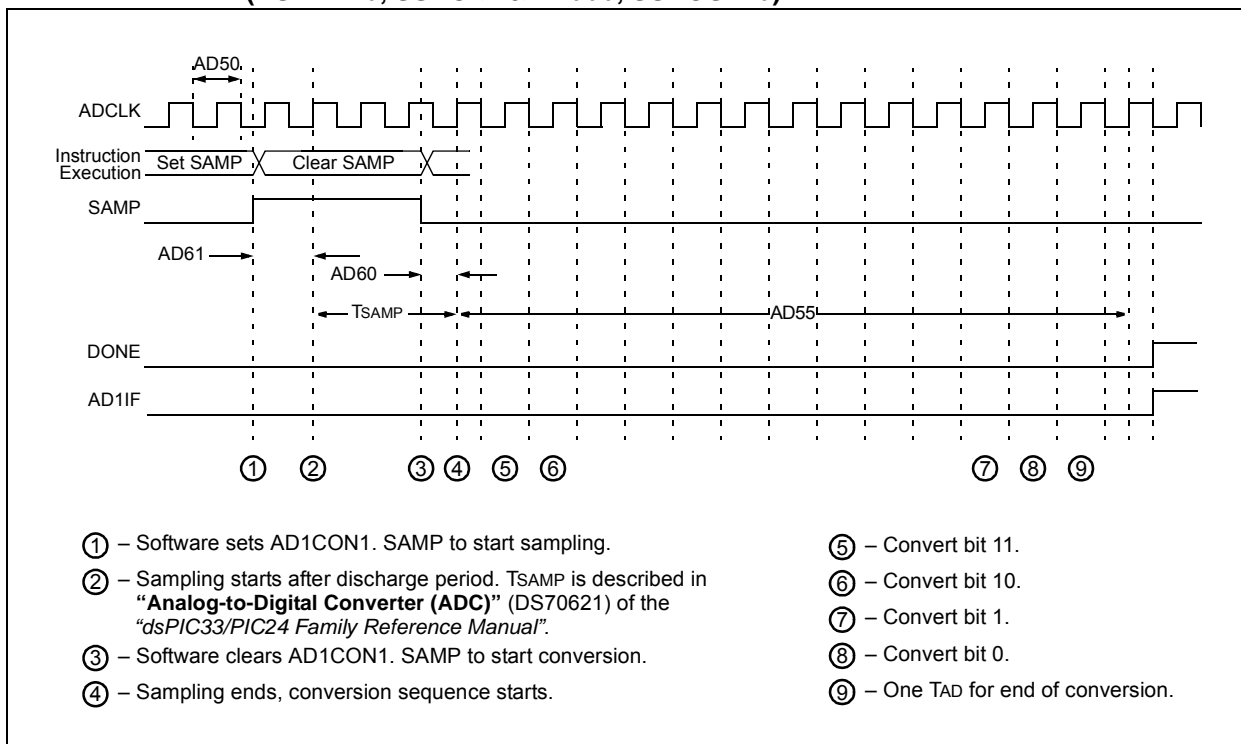

TABLE 33-59: ADCx CONVERSION (12-BIT MODE) TIMING REQUIREMENTS

AC CHARACTERISTICS				Standard Operating Conditions (see Note 2): 3.0V to 3.6V (unless otherwise stated) Operating temperature -40°C ≤ TA ≤ +85°C for Industrial -40°C ≤ TA ≤ +125°C for Extended			
Param No.	Symbol	Characteristic	Min.	Typ. ⁽⁴⁾	Max.	Units	Conditions
Clock Parameters							
AD50	TAD	ADCx Clock Period	117.6	—	—	ns	
AD51	tRC	ADCx Internal RC Oscillator Period	—	250	—	ns	
Conversion Rate							
AD55	tCONV	Conversion Time	—	14 TAD	—	ns	
AD56	FCNV	Throughput Rate	—	—	500	ksps	
AD57a	TSAMP	Sample Time When Sampling Any ANx Input	3 TAD	—	—	—	
AD57b	TSAMP	Sample Time When Sampling the Op Amp Outputs	3 TAD	—	—	—	
Timing Parameters							
AD60	tPCS	Conversion Start from Sample Trigger ⁽¹⁾	2 TAD	—	3 TAD	—	Auto-convert trigger is not selected
AD61	tPSS	Sample Start from Setting Sample (SAMP) bit ⁽¹⁾	2 TAD	—	3 TAD	—	
AD62	tCSS	Conversion Completion to Sample Start (ASAM = 1) ⁽¹⁾	—	0.5 TAD	—	—	
AD63	tDPU	Time to Stabilize Analog Stage from ADCx Off to ADCx On ⁽¹⁾	—	—	20	μs	(Note 3)

Note 1: Because the sample caps will eventually lose charge, clock rates below 10 kHz may affect linearity performance, especially at elevated temperatures.

2: Device is functional at VBORMIN < VDD < VDDMIN, but will have degraded performance. Device functionality is tested, but not characterized. Analog modules: ADC, op amp/comparator and comparator voltage reference, will have degraded performance. Refer to Parameter BO10 in Table 33-12 for the minimum and maximum BOR values.

3: The parameter, tDPU, is the time required for the ADCx module to stabilize at the appropriate level when the module is turned on (ADON (AD1CON1<15>) = 1). During this time, the ADCx result is indeterminate.

4: These parameters are characterized, but not tested in manufacturing.

dsPIC33EPXXXGM3XX/6XX/7XX

FIGURE 33-39: ADC1 CONVERSION (10-BIT MODE) TIMING CHARACTERISTICS (CHPS<1:0> = 01, SIMSAM = 0, ASAM = 0, SSRC<2:0> = 000, SSRCG = 0)

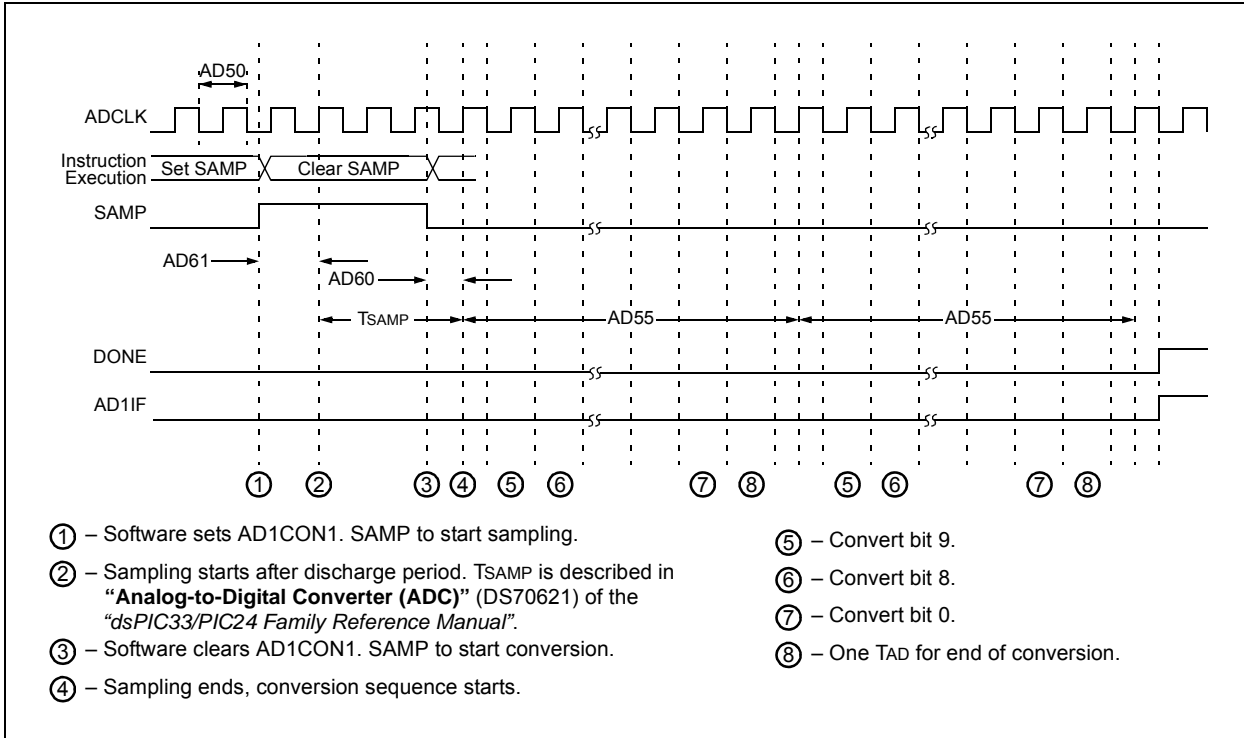

FIGURE 33-40: ADC1 CONVERSION (10-BIT MODE) TIMING CHARACTERISTICS (CHPS<1:0> = 01, SIMSAM = 0, ASAM = 1, SSRC<2:0> = 111, SSRCG = 0, SAMC<4:0> = 00010)

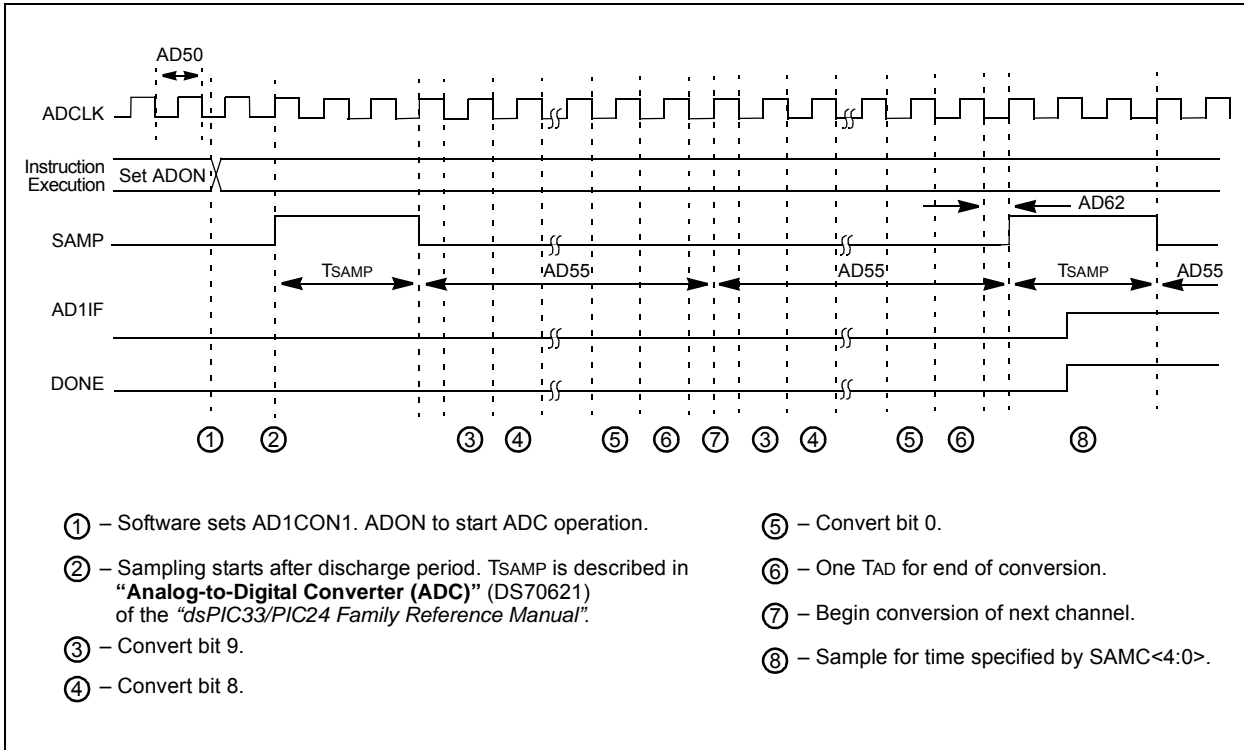

TABLE 33-60: ADCx CONVERSION (10-BIT MODE) TIMING REQUIREMENTS

AC CHARACTERISTICS			Standard Operating Conditions (see Note 1): 3.0V to 3.6V (unless otherwise stated) Operating temperature -40°C ≤ TA ≤ +85°C for Industrial -40°C ≤ TA ≤ +125°C for Extended				
Param No.	Symbol	Characteristic	Min.	Typ. ⁽⁴⁾	Max.	Units	Conditions
Clock Parameters							
AD50	TAD	ADCx Clock Period	75	—	—	ns	
AD51	trc	ADCx Internal RC Oscillator Period	—	250	—	ns	
Conversion Rate							
AD55	tCONV	Conversion Time	—	12 TAD	—	—	
AD56	FCNV	Throughput Rate	—	—	1.1	Msp/s	Using simultaneous sampling
AD57a	TSAMP	Sample Time When Sampling Any ANx Input	2 TAD	—	—	—	
AD57b	TSAMP	Sample Time When Sampling the Op Amp Outputs	4 TAD	—	—	—	
Timing Parameters							
AD60	tPCS	Conversion Start from Sample Trigger ⁽²⁾	2 TAD	—	3 TAD	—	Auto-convert trigger not selected
AD61	tPSS	Sample Start from Setting Sample (SAMP) bit ⁽²⁾	2 TAD	—	3 TAD	—	
AD62	tCSS	Conversion Completion to Sample Start (ASAM = 1) ⁽²⁾	—	0.5 TAD	—	—	
AD63	tDPU	Time to Stabilize Analog Stage from ADC Off to ADC On ⁽²⁾	—	—	20	μs	(Note 3)

- Note 1:** Device is functional at $V_{BORMIN} < V_{DD} < V_{DDMIN}$, but will have degraded performance. Device functionality is tested, but not characterized. Analog modules: ADC, op amp/comparator and comparator voltage reference, will have degraded performance. Refer to Parameter **BO10** in [Table 33-12](#) for the minimum and maximum BOR values.
- 2:** Because the sample caps will eventually lose charge, clock rates below 10 kHz may affect linearity performance, especially at elevated temperatures.
- 3:** The parameter, tDPU, is the time required for the ADCx module to stabilize at the appropriate level when the module is turned on ($AD1CON1 < ADON > = 1$). During this time, the ADCx result is indeterminate.
- 4:** These parameters are characterized, but not tested in manufacturing.

dsPIC33EPXXXGM3XX/6XX/7XX

TABLE 33-61: DMA MODULE TIMING REQUIREMENTS

AC CHARACTERISTICS		Standard Operating Conditions: 3.0V to 3.6V (unless otherwise stated) Operating temperature -40°C ≤ TA ≤ +85°C for Industrial -40°C ≤ TA ≤ +125°C for Extended				
Param No.	Characteristic	Min.	Typ. ⁽¹⁾	Max.	Units	Conditions
DM1	DMA Byte/Word Transfer Latency	1 Tcy ⁽²⁾	—	—	ns	

Note 1: These parameters are characterized, but not tested in manufacturing.

Note 2: Because DMA transfers use the CPU data bus, this time is dependent on other functions on the bus.

34.0 HIGH-TEMPERATURE ELECTRICAL CHARACTERISTICS

This section provides an overview of dsPIC33EPXXXGM3XX/6XX/7XX electrical characteristics for devices operating in an ambient temperature range of -40°C to +150°C.

The specifications between -40°C to +150°C are identical to those shown in [Section 33.0 “Electrical Characteristics”](#) for operation between -40°C to +125°C, with the exception of the parameters listed in this section.

Parameters in this section begin with an H, which denotes High temperature. For example, Parameter [DC10](#) in [Section 33.0 “Electrical Characteristics”](#) is the Industrial and Extended temperature equivalent of [HDC10](#).

Absolute maximum ratings for the dsPIC33EPXXXGM3XX/6XX/7XX high-temperature devices are listed below. Exposure to these maximum rating conditions for extended periods can affect device reliability. Functional operation of the device at these or any other conditions above the parameters indicated in the operation listings of this specification is not implied.

Absolute Maximum Ratings⁽¹⁾

Ambient temperature under bias ⁽²⁾	-40°C to +150°C
Storage temperature	-65°C to +160°C
Voltage on VDD with respect to VSS	-0.3V to +4.0V
Voltage on any pin that is not 5V tolerant with respect to VSS ⁽³⁾	-0.3V to (VDD + 0.3V)
Voltage on any 5V tolerant pin with respect to VSS when VDD < 3.0V ⁽³⁾	-0.3V to 3.6V
Voltage on any 5V tolerant pin with respect to VSS when VDD ≥ 3.0V ⁽³⁾	-0.3V to 5.5V
Maximum current out of VSS pin	60 mA
Maximum current into VDD pin ⁽⁴⁾	60 mA
Maximum junction temperature	+155°C
Maximum current sourced/sunk by any 4x I/O pin	10 mA
Maximum current sourced/sunk by any 8x I/O pin	15 mA
Maximum current sunk by all ports combined	70 mA
Maximum current sourced by all ports combined ⁽⁴⁾	70 mA

Note 1: Stresses above those listed under “Absolute Maximum Ratings” can cause permanent damage to the device. This is a stress rating only, and functional operation of the device at those or any other conditions above those indicated in the operation listings of this specification is not implied. Exposure to maximum rating conditions for extended periods can affect device reliability.

2: AEC-Q100 reliability testing for devices intended to operate at +150°C is 1,000 hours. Any design in which the total operating time from +125°C to +150°C will be greater than 1,000 hours is not warranted without prior written approval from Microchip Technology Inc.

3: Refer to the “[Pin Diagrams](#)” section for 5V tolerant pins.

4: Maximum allowable current is a function of device maximum power dissipation (see [Table 34-2](#)).

dsPIC33EPXXXGM3XX/6XX/7XX

34.1 High-Temperature DC Characteristics

TABLE 34-1: OPERATING MIPS VS. VOLTAGE

Characteristic	VDD Range (in Volts)	Temperature Range (in °C)	Max MIPS
			dsPIC33EPXXXGM3XX/6XX/7XX
HDC5	3.0 to 3.6V ⁽¹⁾	-40°C to +150°C	40

Note 1: Device is functional at $V_{BORMIN} < V_{DD} < V_{DDMIN}$. Analog modules, such as the ADC, may have degraded performance. Device functionality is tested but not characterized.

TABLE 34-2: THERMAL OPERATING CONDITIONS

Rating	Symbol	Min	Typ	Max	Unit
High-Temperature Devices					
Operating Junction Temperature Range	TJ	-40	—	+155	°C
Operating Ambient Temperature Range	TA	-40	—	+150	°C
Power Dissipation: Internal Chip Power Dissipation: $P_{INT} = V_{DD} \times (I_{DD} - \Sigma I_{OH})$ I/O Pin Power Dissipation: $I/O = \Sigma (\{V_{DD} - V_{OH}\} \times I_{OH}) + \Sigma (V_{OL} \times I_{OL})$	PD	PINT + PI/O			W
Maximum Allowed Power Dissipation	PDMAX	$(T_J - T_A)/\theta_{JA}$			W

TABLE 34-3: DC TEMPERATURE AND VOLTAGE SPECIFICATIONS

DC CHARACTERISTICS			Standard Operating Conditions: 3.0V to 3.6V (unless otherwise stated) Operating temperature $-40^\circ\text{C} \leq T_A \leq +150^\circ\text{C}$				
Parameter No.	Symbol	Characteristic	Min	Typ	Max	Units	Conditions
Operating Voltage							
HDC10	Supply Voltage						
	VDD	—	3.0	3.3	3.6	V	-40°C to +150°C

TABLE 34-4: DC CHARACTERISTICS: POWER-DOWN CURRENT (IPD)

DC CHARACTERISTICS			Standard Operating Conditions: 3.0V to 3.6V (unless otherwise stated) Operating temperature $-40^\circ\text{C} \leq T_A \leq +150^\circ\text{C}$			
Parameter No.	Typical	Max	Units	Conditions		
Power-Down Current (IPD)						
HDC60e	4.1	6	mA	+150°C	3.3V	Base Power-Down Current (Notes 1, 3)
HDC61c	15	30	µA	+150°C	3.3V	Watchdog Timer Current: ΔI_{WDT} (Notes 2, 4)

Note 1: Base IPD is measured with all peripherals and clocks shut down. All I/Os are configured as inputs and pulled to Vss. WDT, etc., are all switched off and VREGS (RCON<8>) = 1.

2: The Δ current is the additional current consumed when the module is enabled. This current should be added to the base IPD current.

3: These currents are measured on the device containing the most memory in this family.

4: These parameters are characterized, but are not tested in manufacturing.

dsPIC33EPXXXGM3XX/6XX/7XX

TABLE 34-5: DC CHARACTERISTICS: IDLE CURRENT (I_{IDLE})

DC CHARACTERISTICS			Standard Operating Conditions: 3.0V to 3.6V (unless otherwise stated) Operating temperature $-40^{\circ}\text{C} \leq T_A \leq +150^{\circ}\text{C}$			
Parameter No.	Typical	Max	Units	Conditions		
HDC40e	3.6	8	mA	+150°C	3.3V	10 MIPS
HDC42e	5	15	mA	+150°C	3.3V	20 MIPS
HDC44e	10	20	mA	+150°C	3.3V	40 MIPS

TABLE 34-6: DC CHARACTERISTICS: OPERATING CURRENT (I_{DD})

DC CHARACTERISTICS			Standard Operating Conditions: 3.0V to 3.6V (unless otherwise stated) Operating temperature $-40^{\circ}\text{C} \leq T_A \leq +150^{\circ}\text{C}$			
Parameter No.	Typical	Max	Units	Conditions		
HDC20	11	25	mA	+150°C	3.3V	10 MIPS
HDC22	15	30	mA	+150°C	3.3V	20 MIPS
HDC23	21	50	mA	+150°C	3.3V	40 MIPS

TABLE 34-7: DC CHARACTERISTICS: DOZE CURRENT (I_{DOZE})

DC CHARACTERISTICS			Standard Operating Conditions: 3.0V to 3.6V (unless otherwise stated) Operating temperature $-40^{\circ}\text{C} \leq T_A \leq +150^{\circ}\text{C}$				
Parameter No.	Typical	Max	Doze Ratio	Units	Conditions		
HDC72a	25	45	1:2	mA	+150°C	3.3V	40 MIPS
HDC72g ⁽¹⁾	14	33	1:128	mA			

Note 1: Parameters with Doze ratios of 1:64 and 1:128 are characterized, but are not tested in manufacturing.

dsPIC33EPXXXGM3XX/6XX/7XX

TABLE 34-8: DC CHARACTERISTICS: I/O PIN OUTPUT SPECIFICATIONS

DC CHARACTERISTICS			Standard Operating Conditions: 3.0V to 3.6V (unless otherwise stated) Operating temperature $-40^{\circ}\text{C} \leq T_A \leq +150^{\circ}\text{C}$				
Param.	Symbol	Characteristic	Min.	Typ.	Max.	Units	Conditions
HDO10	VOL	Output Low Voltage 4x Sink Driver Pins ⁽²⁾	—	—	0.4	V	$I_{OL} \leq 5 \text{ mA}$, $V_{DD} = 3.3\text{V}$ (Note 1)
		Output Low Voltage 8x Sink Driver Pins ⁽³⁾	—	—	0.4	V	$I_{OL} \leq 8 \text{ mA}$, $V_{DD} = 3.3\text{V}$ (Note 1)
HDO20	VOH	Output High Voltage 4x Source Driver Pins ⁽²⁾	2.4	—	—	V	$I_{OH} \geq -10 \text{ mA}$, $V_{DD} = 3.3\text{V}$ (Note 1)
		Output High Voltage 8x Source Driver Pins ⁽³⁾	2.4	—	—	V	$I_{OH} \geq 15 \text{ mA}$, $V_{DD} = 3.3\text{V}$ (Note 1)
HDO20A	VOH1	Output High Voltage 4x Source Driver Pins ⁽²⁾	1.5	—	—	V	$I_{OH} \geq -3.9 \text{ mA}$, $V_{DD} = 3.3\text{V}$ (Note 1)
			2.0	—	—		$I_{OH} \geq -3.7 \text{ mA}$, $V_{DD} = 3.3\text{V}$ (Note 1)
			3.0	—	—		$I_{OH} \geq -2 \text{ mA}$, $V_{DD} = 3.3\text{V}$ (Note 1)
		Output High Voltage 8x Source Driver Pins ⁽³⁾	1.5	—	—	V	$I_{OH} \geq -7.5 \text{ mA}$, $V_{DD} = 3.3\text{V}$ (Note 1)
			2.0	—	—		$I_{OH} \geq -6.8 \text{ mA}$, $V_{DD} = 3.3\text{V}$ (Note 1)
			3.0	—	—		$I_{OH} \geq -3 \text{ mA}$, $V_{DD} = 3.3\text{V}$ (Note 1)

Note 1: Parameters are characterized, but not tested.

2: Includes all I/O pins that are not 8x Sink Driver pins (see below).

3: Includes the following pins:

For 44-pin devices: RA3, RA4, RA7, RA9, RA10, RB7, RB<15:9>, RC1 and RC<9:3>

For 64-pin devices: RA4, RA7, RA<10:9>, RB7, RB<15:9>, RC1, RC<9:3>, RC15 and RG<8:7>

For 100-pin devices: RA4, RA7, RA9, RA10, RB7, RB<15:9>, RC1, RC<9:3>, RC15, RD<3:1> and RG<8:6>

TABLE 34-9: DC CHARACTERISTICS: PROGRAM MEMORY

DC CHARACTERISTICS			Standard Operating Conditions: 3.0V to 3.6V (unless otherwise stated) Operating temperature $-40^{\circ}\text{C} \leq T_A \leq +150^{\circ}\text{C}$				
Param.	Symbol	Characteristic ⁽¹⁾	Min.	Typ.	Max.	Units	Conditions
HD130	EP	Program Flash Memory Cell Endurance	10,000	—	—	E/W	-40°C to $+150^{\circ}\text{C}$ ⁽²⁾ 1000 E/W cycles or less and no other specifications are violated
HD134	TRETD	Characteristic Retention	20	—	—	Year	

Note 1: These parameters are assured by design, but are not characterized or tested in manufacturing.

2: Programming of the Flash memory is allowed up to $+150^{\circ}\text{C}$.

34.2 AC Characteristics and Timing Parameters

The information contained in this section defines dsPIC33EPXXXGM3XX/6XX/7XX AC characteristics and timing parameters for high-temperature devices. However, all AC timing specifications in this section are the same as those in [Section 33.2 “AC Characteristics and Timing Parameters”](#), with the exception of the parameters listed in this section.

Parameters in this section begin with an H, which denotes High temperature. For example, Parameter OS53 in [Section 33.2 “AC Characteristics and Timing Parameters”](#) is the Industrial and Extended temperature equivalent of HOS53.

TABLE 34-10: TEMPERATURE AND VOLTAGE SPECIFICATIONS – AC

AC CHARACTERISTICS	Standard Operating Conditions: 3.0V to 3.6V (unless otherwise stated) Operating temperature $-40^{\circ}\text{C} \leq T_A \leq +150^{\circ}\text{C}$ Operating voltage VDD range as described in Table 34-1 .
---------------------------	--

FIGURE 34-1: LOAD CONDITIONS FOR DEVICE TIMING SPECIFICATIONS

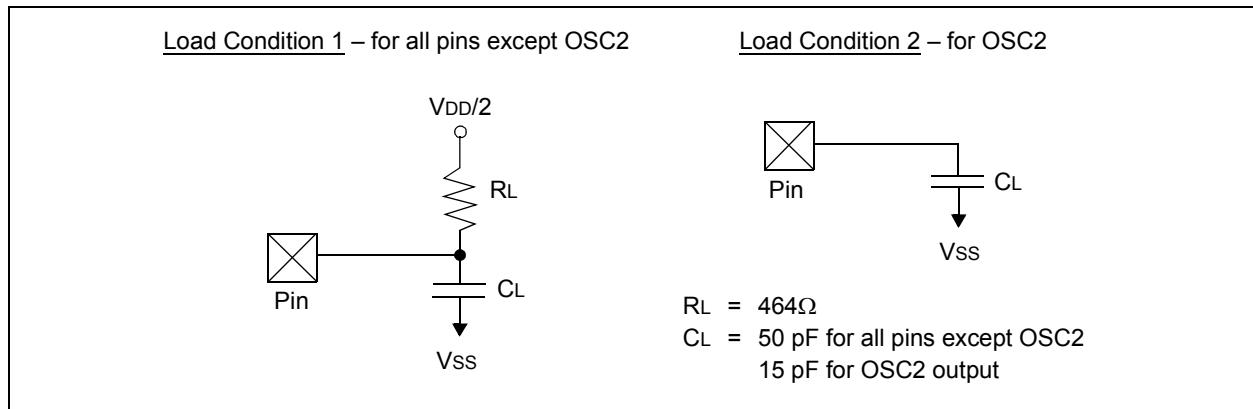

dsPIC33EPXXXGM3XX/6XX/7XX

TABLE 34-11: PLL CLOCK TIMING SPECIFICATIONS

AC CHARACTERISTICS			Standard Operating Conditions: 3.0V to 3.6V (unless otherwise stated) Operating temperature $-40^{\circ}\text{C} \leq T_A \leq +150^{\circ}\text{C}$				
Param No.	Symbol	Characteristic	Min	Typ	Max	Units	Conditions
HOS53	DCLK	CLKO Stability (Jitter) ⁽¹⁾	-5	0.5	5	%	Measured over 100 ms period

Note 1: These parameters are characterized by similarity, but are not tested in manufacturing. This specification is based on clock cycle by clock cycle measurements. To calculate the effective jitter for individual time bases or communication clocks use this formula:

$$\text{Peripheral Clock Jitter} = \frac{DCLK}{\sqrt{\left(\frac{FOSC}{\text{Peripheral Bit Rate Clock}}\right)}}$$

For example: FOSC = 32 MHz, DCLK = 5%, SPIx bit rate clock (i.e., SCKx) is 2 MHz.

$$\text{SPI SCK Jitter} = \left[\frac{DCLK}{\sqrt{\left(\frac{32 \text{ MHz}}{2 \text{ MHz}}\right)}} \right] = \left[\frac{5\%}{\sqrt{16}} \right] = \left[\frac{5\%}{4} \right] = 1.25\%$$

TABLE 34-12: INTERNAL FRC ACCURACY

AC CHARACTERISTICS		Standard Operating Conditions: 3.0V to 3.6V (unless otherwise stated) Operating temperature $-40^{\circ}\text{C} \leq T_A \leq +150^{\circ}\text{C}$					
Param No.	Characteristic	Min	Typ	Max	Units	Conditions	
Internal FRC Accuracy @ FRC Frequency = 7.3728 MHz							
HF20	FRC	-3	—	+3	%	$-40^{\circ}\text{C} \leq T_A \leq +150^{\circ}\text{C}$	VDD = 3.0-3.6V

TABLE 34-13: INTERNAL RC ACCURACY

AC CHARACTERISTICS		Standard Operating Conditions: 3.0V to 3.6V (unless otherwise stated) Operating temperature $-40^{\circ}\text{C} \leq T_A \leq +150^{\circ}\text{C}$					
Param No.	Characteristic	Min	Typ	Max	Units	Conditions	
LPRC @ 32.768 kHz^(1,2)							
HF21	LPRC	-30	—	+30	%	$-40^{\circ}\text{C} \leq T_A \leq +150^{\circ}\text{C}$	VDD = 3.0-3.6V

Note 1: Change of LPRC frequency as VDD changes.

Note 2: LPRC accuracy impacts the Watchdog Timer Time-out Period (TWDT1). See [Section 30.5 “Watchdog Timer \(WDT\)”](#) for more information.

TABLE 34-14: ADCx MODULE SPECIFICATIONS (12-BIT MODE)

AC CHARACTERISTICS			Standard Operating Conditions: 3.0V to 3.6V (unless otherwise stated) Operating temperature $-40^{\circ}\text{C} \leq T_A \leq +150^{\circ}\text{C}$				
Param No.	Symbol	Characteristic	Min	Typ	Max	Units	Conditions
ADC Accuracy (12-Bit Mode)⁽¹⁾							
HAD20a	Nr	Resolution ⁽³⁾	12 Data Bits			bits	
HAD21a	INL	Integral Nonlinearity	-6	—	6	LSb	V _{INL} = AV _{SS} = V _{REFL} = 0V, AV _{DD} = V _{REFH} = 3.6V
HAD22a	DNL	Differential Nonlinearity	-1	—	1	LSb	V _{INL} = AV _{SS} = V _{REFL} = 0V, AV _{DD} = V _{REFH} = 3.6V
HAD23a	GERR	Gain Error	-10	—	10	LSb	V _{INL} = AV _{SS} = V _{REFL} = 0V, AV _{DD} = V _{REFH} = 3.6V
HAD24a	E _{OFF}	Offset Error	-5	—	5	LSb	V _{INL} = AV _{SS} = V _{REFL} = 0V, AV _{DD} = V _{REFH} = 3.6V
Dynamic Performance (12-Bit Mode)⁽²⁾							
HAD33a	F _{NYQ}	Input Signal Bandwidth	—	—	200	kHz	

Note 1: These parameters are characterized, but are tested at 20 ksps only.

2: These parameters are characterized by similarity, but are not tested in manufacturing.

3: Injection currents $> |0|$ can affect the ADC results by approximately 4-6 counts.

TABLE 34-15: ADCx MODULE SPECIFICATIONS (10-BIT MODE)

AC CHARACTERISTICS			Standard Operating Conditions: 3.0V to 3.6V (unless otherwise stated) Operating temperature $-40^{\circ}\text{C} \leq T_A \leq +150^{\circ}\text{C}$				
Param No.	Symbol	Characteristic	Min	Typ	Max	Units	Conditions
ADC Accuracy (10-Bit Mode)⁽¹⁾							
HAD20b	Nr	Resolution ⁽³⁾	10 Data Bits			bits	
HAD21b	INL	Integral Nonlinearity	-1.5	—	1.5	LSb	V _{INL} = AV _{SS} = V _{REFL} = 0V, AV _{DD} = V _{REFH} = 3.6V
HAD22b	DNL	Differential Nonlinearity	-0.25	—	0.25	LSb	V _{INL} = AV _{SS} = V _{REFL} = 0V, AV _{DD} = V _{REFH} = 3.6V
HAD23b	GERR	Gain Error	-2.5	—	2.5	LSb	V _{INL} = AV _{SS} = V _{REFL} = 0V, AV _{DD} = V _{REFH} = 3.6V
HAD24b	E _{OFF}	Offset Error	-1.25	—	1.25	LSb	V _{INL} = AV _{SS} = V _{REFL} = 0V, AV _{DD} = V _{REFH} = 3.6V
Dynamic Performance (10-Bit Mode)⁽²⁾							
HAD33b	F _{NYQ}	Input Signal Bandwidth	—	—	400	kHz	

Note 1: These parameters are characterized, but are tested at 20 ksps only.

2: These parameters are characterized by similarity, but are not tested in manufacturing.

3: Injection currents $> |0|$ can affect the ADC results by approximately 4-6 counts.

NOTES:

35.0 PACKAGING INFORMATION

35.1 Package Marking Information

44-Lead TQFP (10x10x1 mm)

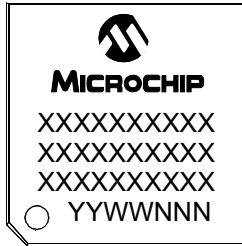

Example

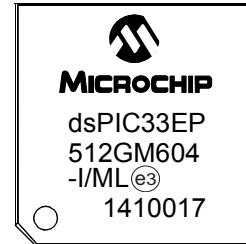

44-Lead QFN (8x8x0.9 mm)



Example



64-Lead QFN (9x9x0.9 mm)

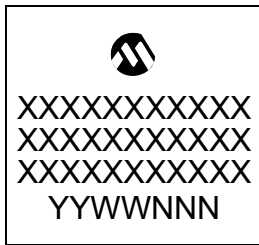

Example



Legend:	XX...X	Customer-specific information
	Y	Year code (last digit of calendar year)
	YY	Year code (last 2 digits of calendar year)
	WW	Week code (week of January 1 is week '01')
	NNN	Alphanumeric traceability code
	(e3)	Pb-free JEDEC designator for Matte Tin (Sn)
	*	This package is Pb-free. The Pb-free JEDEC designator (e3) can be found on the outer packaging for this package.

Note: In the event the full Microchip part number cannot be marked on one line, it will be carried over to the next line, thus limiting the number of available characters for customer-specific information.

dsPIC33EPXXXGM3XX/6XX/7XX

35.1 Package Marking Information (Continued)

64-Lead TQFP (10x10x1 mm)

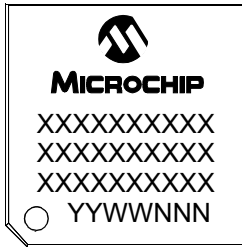

Example

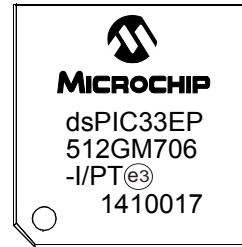

100-Lead TQFP (12x12x1 mm)

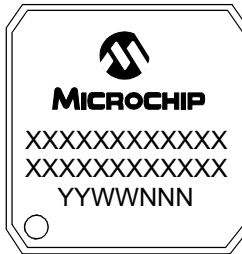

Example

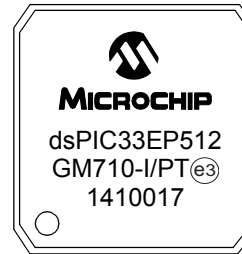

100-Lead TQFP (14x14x1 mm)

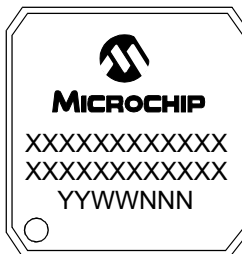

Example



121-Lead TFBGA (10x10x1.1 mm)

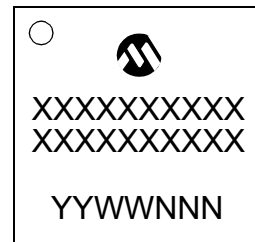

Example

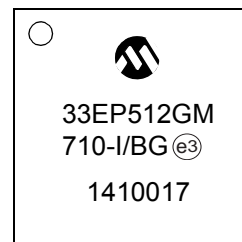

35.2 Package Details

44-Lead Plastic Thin Quad Flatpack (PT) – 10x10x1 mm Body, 2.00 mm [TQFP]

Note: For the most current package drawings, please see the Microchip Packaging Specification located at <http://www.microchip.com/packaging>

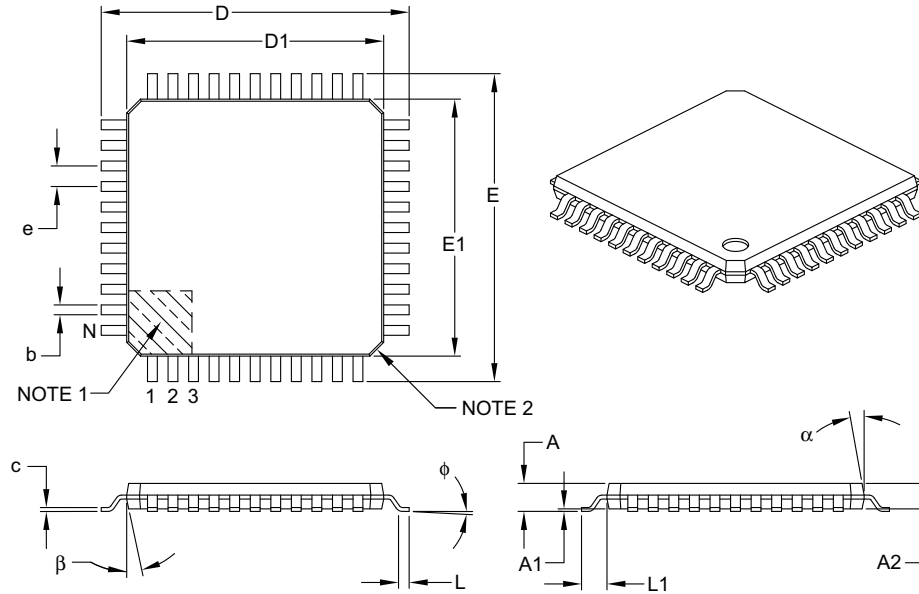

Dimension Limits	Units	MILLIMETERS		
		MIN	NOM	MAX
Number of Leads	N	44		
Lead Pitch	e	0.80 BSC		
Overall Height	A	–	–	1.20
Molded Package Thickness	A2	0.95	1.00	1.05
Standoff	A1	0.05	–	0.15
Foot Length	L	0.45	0.60	0.75
Footprint	L1	1.00 REF		
Foot Angle	ϕ	0°	3.5°	7°
Overall Width	E	12.00 BSC		
Overall Length	D	12.00 BSC		
Molded Package Width	E1	10.00 BSC		
Molded Package Length	D1	10.00 BSC		
Lead Thickness	c	0.09	–	0.20
Lead Width	b	0.30	0.37	0.45
Mold Draft Angle Top	α	11°	12°	13°
Mold Draft Angle Bottom	β	11°	12°	13°

Notes:

- Pin 1 visual index feature may vary, but must be located within the hatched area.
- Chamfers at corners are optional; size may vary.
- Dimensions D1 and E1 do not include mold flash or protrusions. Mold flash or protrusions shall not exceed 0.25 mm per side.
- Dimensioning and tolerancing per ASME Y14.5M.

BSC: Basic Dimension. Theoretically exact value shown without tolerances.

REF: Reference Dimension, usually without tolerance, for information purposes only.

Microchip Technology Drawing C04-076B

dsPIC33EPXXXGM3XX/6XX/7XX

44-Lead Plastic Thin Quad Flatpack (PT) 10X10X1 mm Body, 2.00 mm Footprint [TQFP]

Note: For the most current package drawings, please see the Microchip Packaging Specification located at <http://www.microchip.com/packaging>

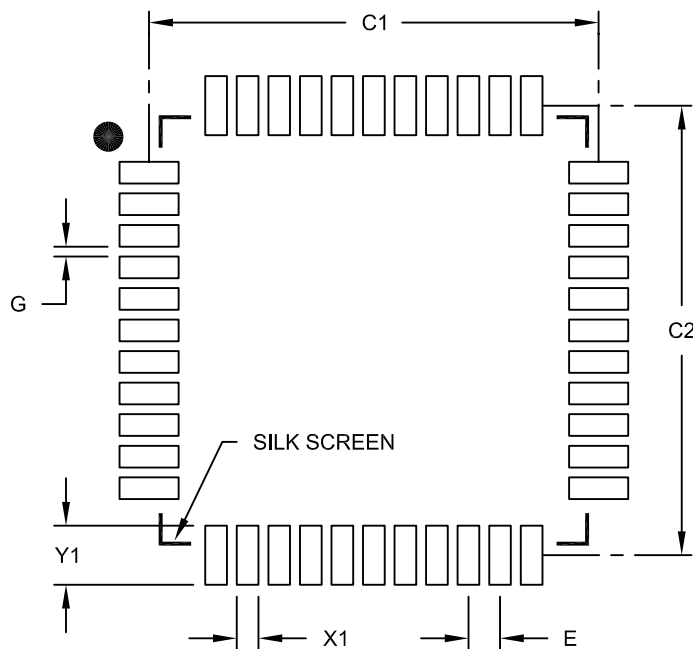

RECOMMENDED LAND PATTERN

Dimension Limits	Units	MILLIMETERS		
		MIN	NOM	MAX
Contact Pitch	E	0.80 BSC		
Contact Pad Spacing	C1		11.40	
Contact Pad Spacing	C2		11.40	
Contact Pad Width (X44)	X1			0.55
Contact Pad Length (X44)	Y1			1.50
Distance Between Pads	G	0.25		

Notes:

1. Dimensioning and tolerancing per ASME Y14.5M

BSC: Basic Dimension. Theoretically exact value shown without tolerances.

Microchip Technology Drawing No. C04-2076B

dsPIC33EPXXXGM3XX/6XX/7XX

44-Lead Plastic Quad Flat, No Lead Package (ML) - 8x8 mm Body [QFN]

Note: For the most current package drawings, please see the Microchip Packaging Specification located at <http://www.microchip.com/packaging>

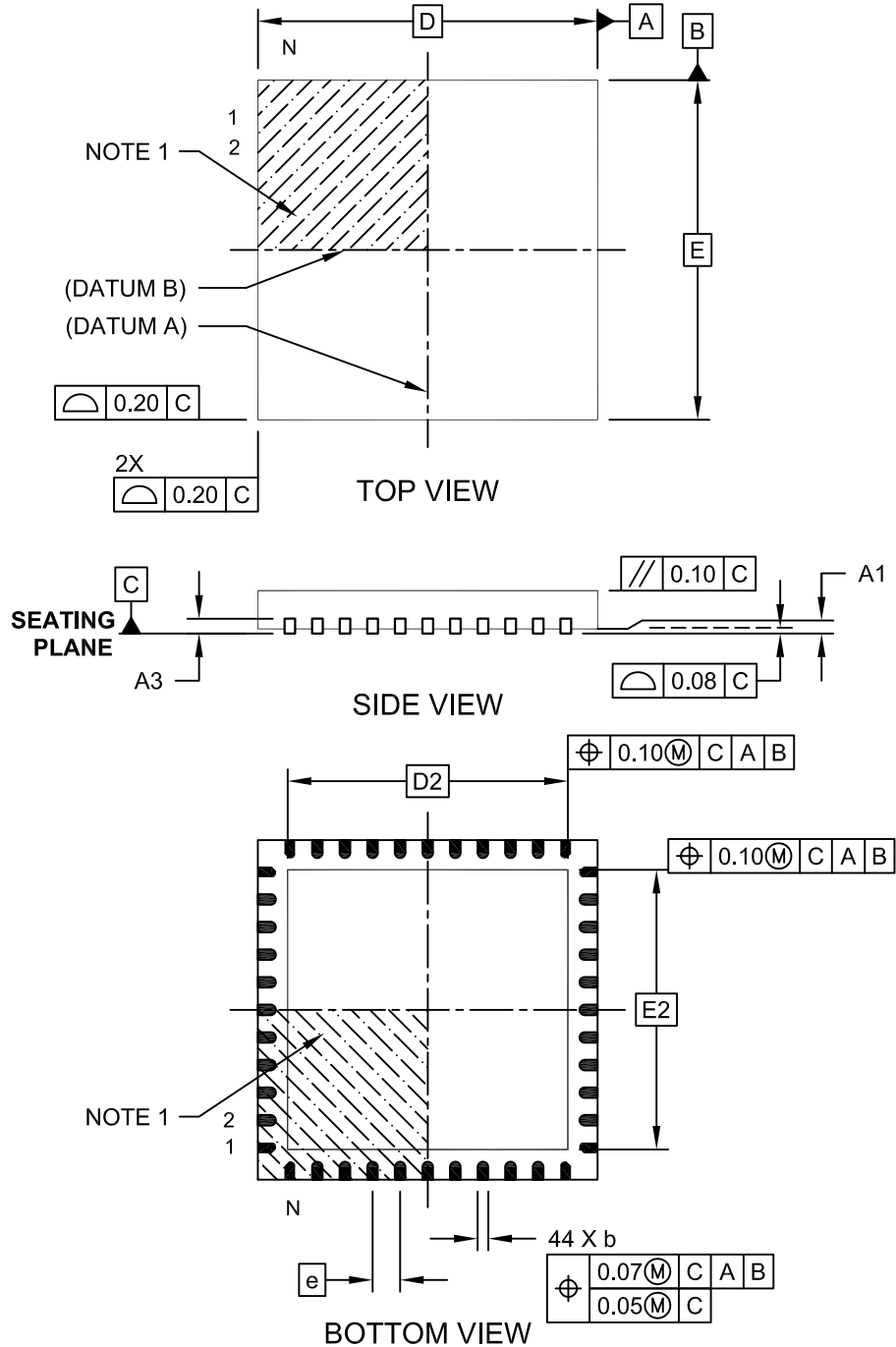

Microchip Technology Drawing C04-103C Sheet 1 of 2

dsPIC33EPXXXGM3XX/6XX/7XX

44-Lead Plastic Quad Flat, No Lead Package (ML) - 8x8 mm Body [QFN]

Note: For the most current package drawings, please see the Microchip Packaging Specification located at <http://www.microchip.com/packaging>

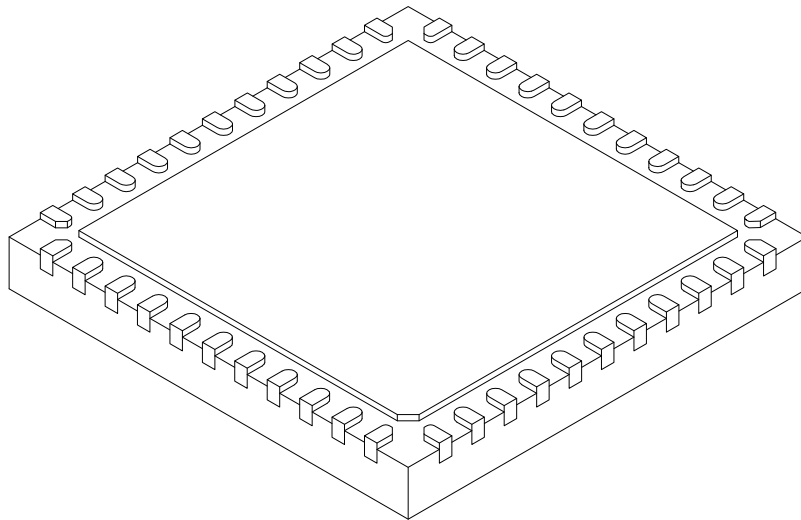

Dimension Limits	Units	MILLIMETERS		
		MIN	NOM	MAX
Number of Pins	N	44		
Pitch	e	0.65 BSC		
Overall Height	A	0.80	0.90	1.00
Standoff	A1	0.00	0.02	0.05
Terminal Thickness	A3	0.20 REF		
Overall Width	E	8.00 BSC		
Exposed Pad Width	E2	6.25	6.45	6.60
Overall Length	D	8.00 BSC		
Exposed Pad Length	D2	6.25	6.45	6.60
Terminal Width	b	0.20	0.30	0.35
Terminal Length	L	0.30	0.40	0.50
Terminal-to-Exposed-Pad	K	0.20	-	-

Notes:

1. Pin 1 visual index feature may vary, but must be located within the hatched area.
2. Package is saw singulated
3. Dimensioning and tolerancing per ASME Y14.5M

BSC: Basic Dimension. Theoretically exact value shown without tolerances.

REF: Reference Dimension. usually without tolerance. for information purposes only.

Microchip Technology Drawing C04-103C Sheet 2 of 2

dsPIC33EPXXXGM3XX/6XX/7XX

44-Lead Plastic Quad Flat, No Lead Package (ML) - 8x8 mm Body [QFN]

Note: For the most current package drawings, please see the Microchip Packaging Specification located at <http://www.microchip.com/packaging>

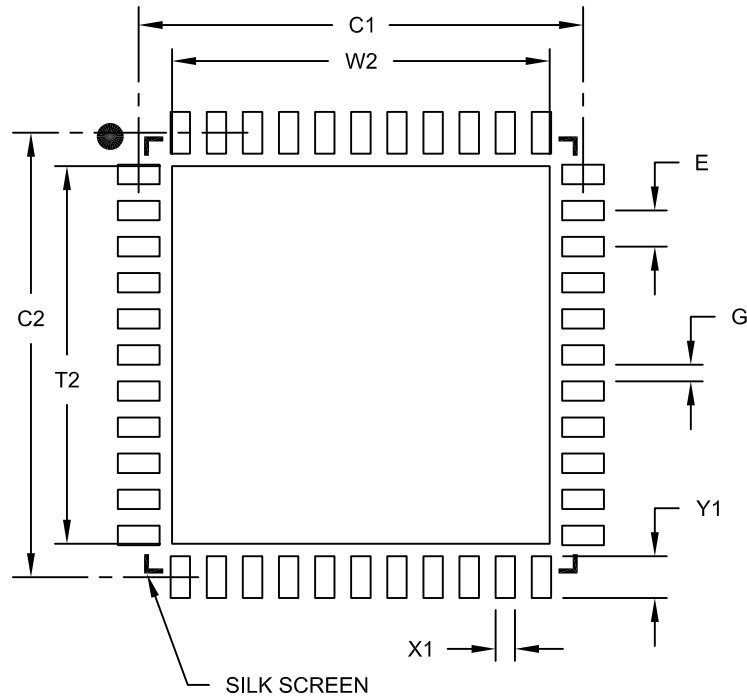

RECOMMENDED LAND PATTERN

Dimension Limits	Units	MILLIMETERS		
		MIN	NOM	MAX
Contact Pitch	E	0.65 BSC		
Optional Center Pad Width	W2			6.60
Optional Center Pad Length	T2			6.60
Contact Pad Spacing	C1		8.00	
Contact Pad Spacing	C2		8.00	
Contact Pad Width (X44)	X1			0.35
Contact Pad Length (X44)	Y1			0.85
Distance Between Pads	G	0.25		

Notes:

1. Dimensioning and tolerancing per ASME Y14.5M

BSC: Basic Dimension. Theoretically exact value shown without tolerances.

Microchip Technology Drawing No. C04-2103B

dsPIC33EPXXXGM3XX/6XX/7XX

64-Lead Plastic Quad Flat, No Lead Package (MR) – 9x9x0.9 mm Body [QFN] With 7.15 x 7.15 Exposed Pad

Note: For the most current package drawings, please see the Microchip Packaging Specification located at <http://www.microchip.com/packaging>

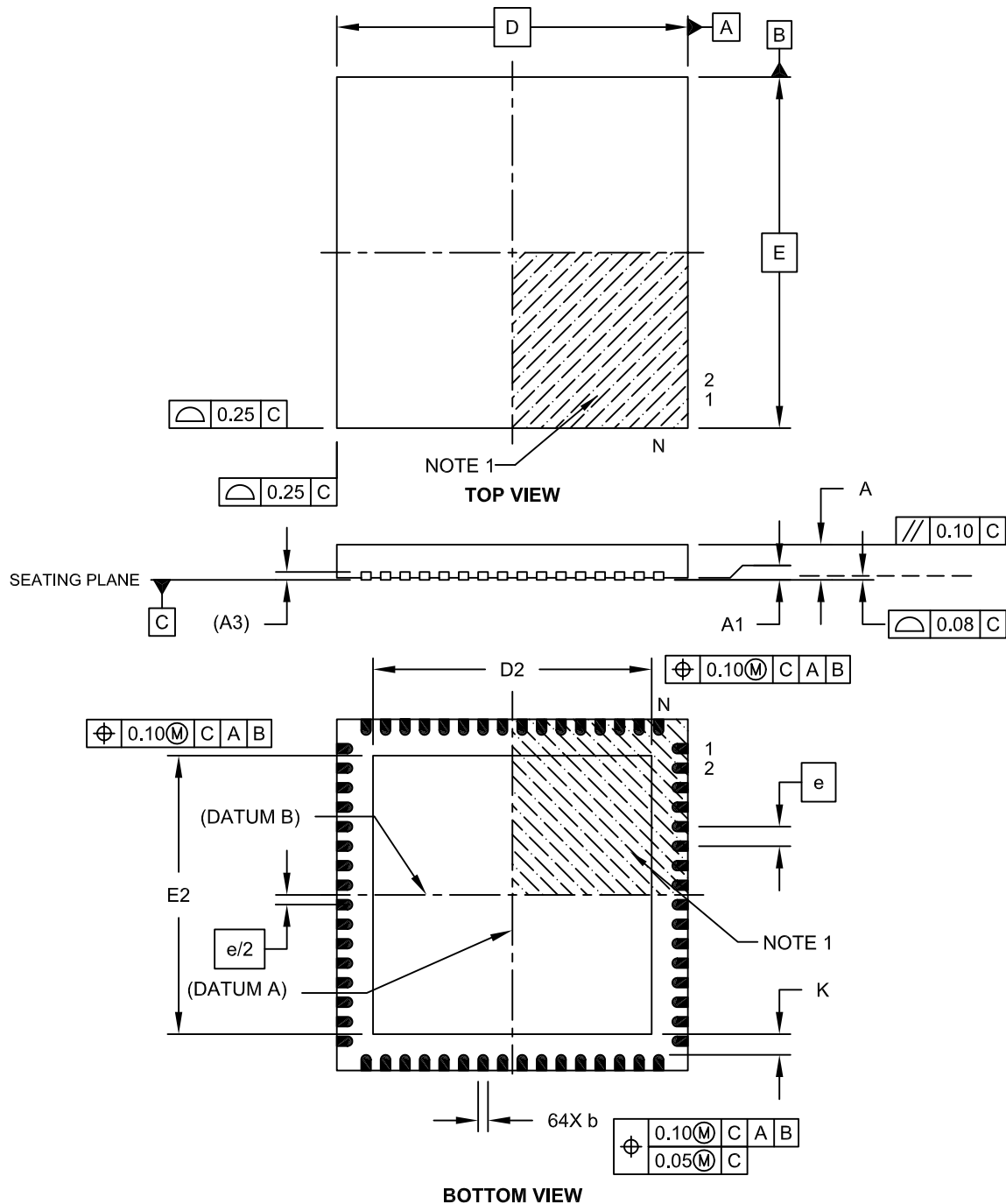

Microchip Technology Drawing C04-149C Sheet 1 of 2

dsPIC33EPXXXGM3XX/6XX/7XX

64-Lead Plastic Quad Flat, No Lead Package (MR) – 9x9x0.9 mm Body [QFN] With 7.15 x 7.15 Exposed Pad

Note: For the most current package drawings, please see the Microchip Packaging Specification located at <http://www.microchip.com/packaging>

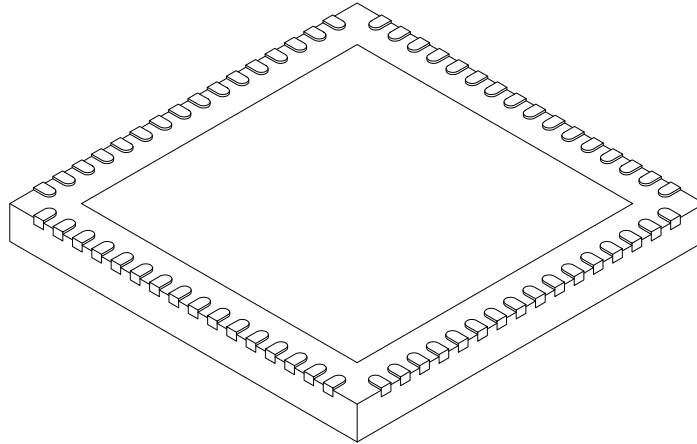

Dimension Limits	Units	MILLIMETERS		
		MIN	NOM	MAX
Number of Pins	N	64		
Pitch	e	0.50 BSC		
Overall Height	A	0.80	0.90	1.00
Standoff	A1	0.00	0.02	0.05
Contact Thickness	A3	0.20 REF		
Overall Width	E	9.00 BSC		
Exposed Pad Width	E2	7.05	7.15	7.50
Overall Length	D	9.00 BSC		
Exposed Pad Length	D2	7.05	7.15	7.50
Contact Width	b	0.18	0.25	0.30
Contact Length	L	0.30	0.40	0.50
Contact-to-Exposed Pad	K	0.20	-	-

Notes:

1. Pin 1 visual index feature may vary, but must be located within the hatched area.
2. Package is saw singulated.
3. Dimensioning and tolerancing per ASME Y14.5M.
BSC: Basic Dimension. Theoretically exact value shown without tolerances.
REF: Reference Dimension, usually without tolerance, for information purposes only.

Microchip Technology Drawing C04-149C Sheet 2 of 2

dsPIC33EPXXXGM3XX/6XX/7XX

64-Lead Plastic Quad Flat, No Lead Package (MR) – 9x9x0.9 mm Body [QFN]
With 0.40 mm Contact Length

Note: For the most current package drawings, please see the Microchip Packaging Specification located at <http://www.microchip.com/packaging>

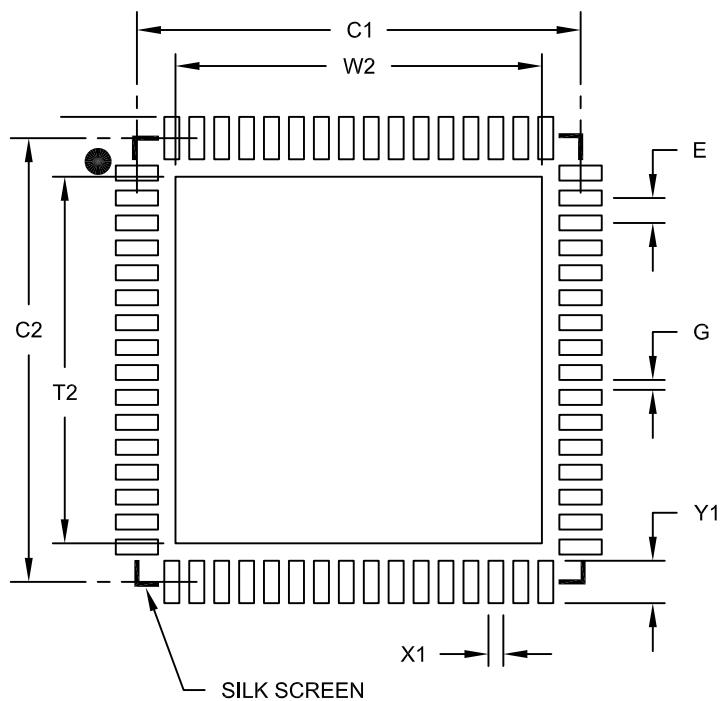

RECOMMENDED LAND PATTERN

Dimension Limits	Units	MILLIMETERS		
		MIN	NOM	MAX
Contact Pitch	E	0.50 BSC		
Optional Center Pad Width	W2			7.35
Optional Center Pad Length	T2			7.35
Contact Pad Spacing	C1		8.90	
Contact Pad Spacing	C2		8.90	
Contact Pad Width (X64)	X1			0.30
Contact Pad Length (X64)	Y1			0.85
Distance Between Pads	G	0.20		

Notes:

1. Dimensioning and tolerancing per ASME Y14.5M

BSC: Basic Dimension. Theoretically exact value shown without tolerances.

Microchip Technology Drawing No. C04-2149A

dsPIC33EPXXXGM3XX/6XX/7XX

64-Lead Plastic Thin Quad Flatpack (PT)-10x10x1 mm Body, 2.00 mm Footprint [TQFP]

Note: For the most current package drawings, please see the Microchip Packaging Specification located at <http://www.microchip.com/packaging>

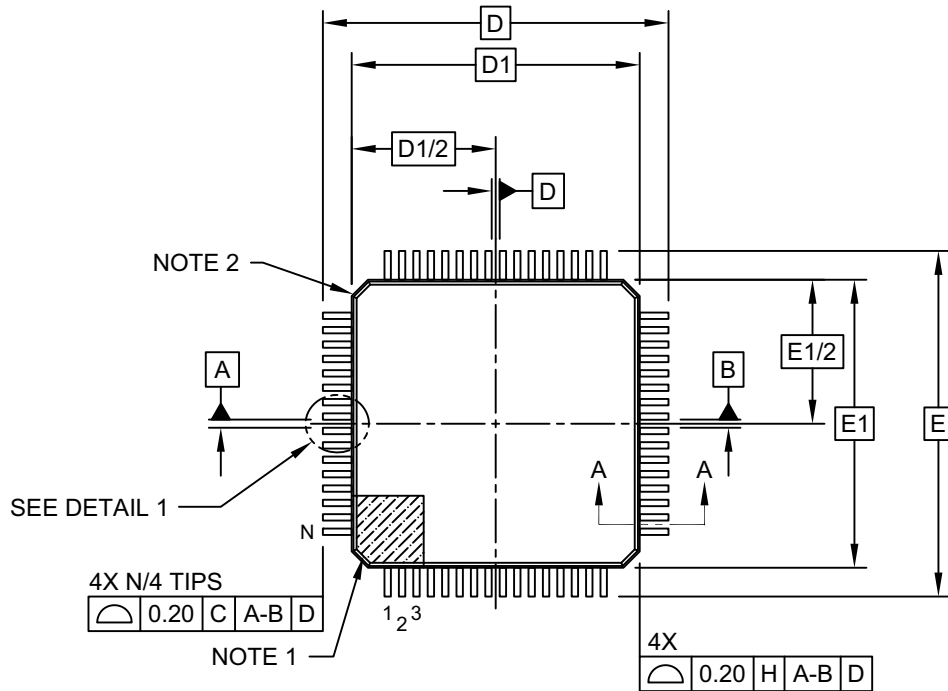

TOP VIEW

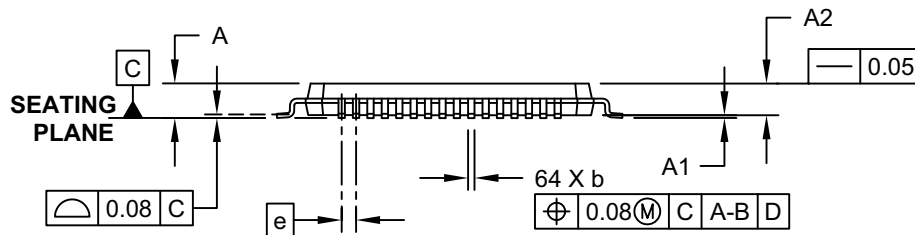

SIDE VIEW

Microchip Technology Drawing C04-085C Sheet 1 of 2

dsPIC33EPXXXGM3XX/6XX/7XX

64-Lead Plastic Thin Quad Flatpack (PT)-10x10x1 mm Body, 2.00 mm Footprint [TQFP]

Note: For the most current package drawings, please see the Microchip Packaging Specification located at <http://www.microchip.com/packaging>

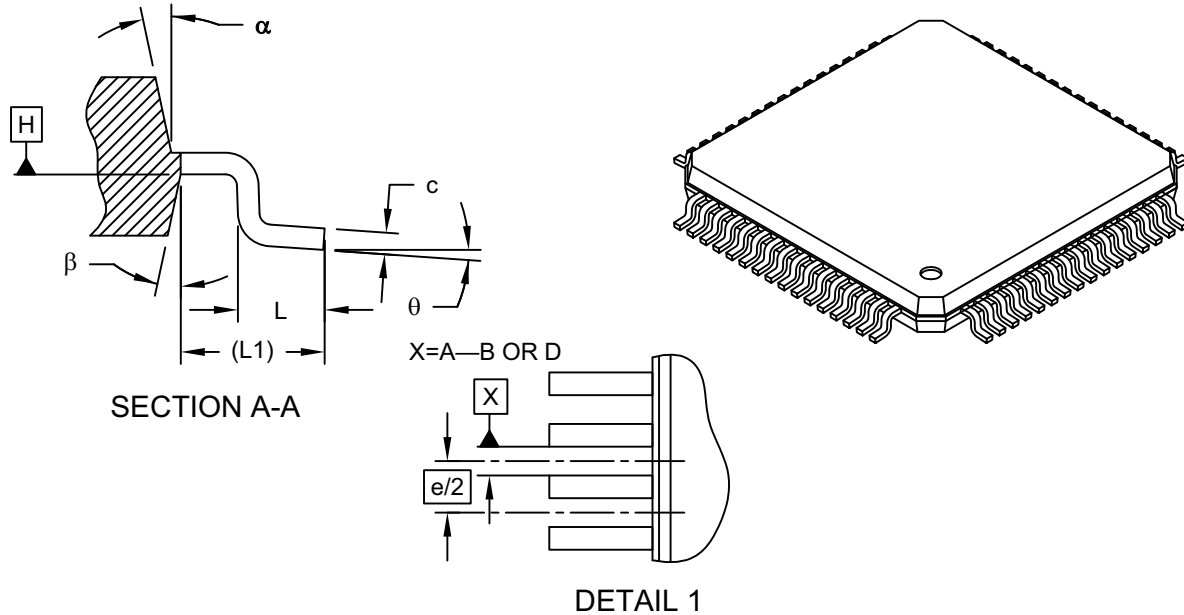

Dimension Limits	Units	MILLIMETERS		
		MIN	NOM	MAX
Number of Leads	N	64		
Lead Pitch	e	0.50 BSC		
Overall Height	A	-	-	1.20
Molded Package Thickness	A2	0.95	1.00	1.05
Standoff	A1	0.05	-	0.15
Foot Length	L	0.45	0.60	0.75
Footprint	L1	1.00 REF		
Foot Angle	ϕ	0°	3.5°	7°
Overall Width	E	12.00 BSC		
Overall Length	D	12.00 BSC		
Molded Package Width	E1	10.00 BSC		
Molded Package Length	D1	10.00 BSC		
Lead Thickness	c	0.09	-	0.20
Lead Width	b	0.17	0.22	0.27
Mold Draft Angle Top	α	11°	12°	13°
Mold Draft Angle Bottom	β	11°	12°	13°

Notes:

- Pin 1 visual index feature may vary, but must be located within the hatched area.
- Chamfers at corners are optional; size may vary.
- Dimensions D1 and E1 do not include mold flash or protrusions. Mold flash or protrusions shall not exceed 0.25mm per side.
- Dimensioning and tolerancing per ASME Y14.5M

BSC: Basic Dimension. Theoretically exact value shown without tolerances.

REF: Reference Dimension, usually without tolerance, for information purposes only.

Microchip Technology Drawing C04-085C Sheet 2 of 2

dsPIC33EPXXXGM3XX/6XX/7XX

64-Lead Plastic Thin Quad Flatpack (PT) 10x10x1 mm Body, 2.00 mm Footprint [TQFP]

Note: For the most current package drawings, please see the Microchip Packaging Specification located at <http://www.microchip.com/packaging>

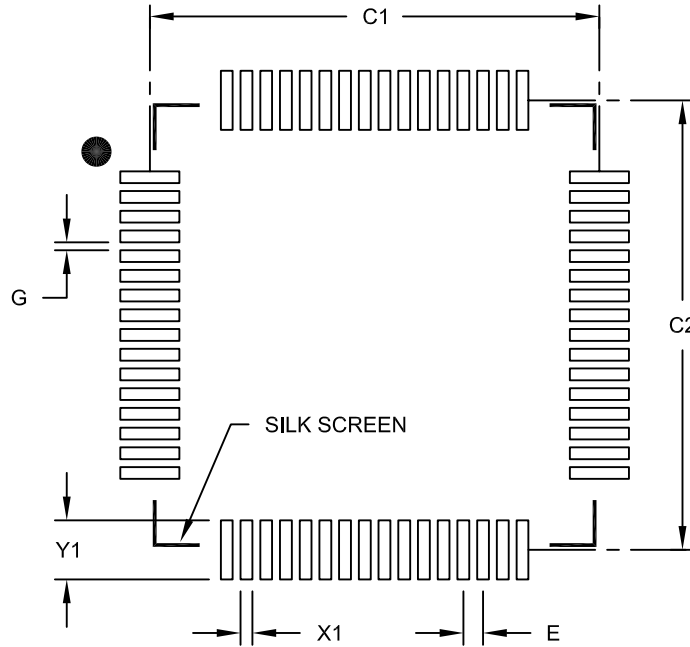

RECOMMENDED LAND PATTERN

		Units	MILLIMETERS		
Dimension Limits			MIN	NOM	MAX
Contact Pitch	E		0.50 BSC		
Contact Pad Spacing	C1			11.40	
Contact Pad Spacing	C2			11.40	
Contact Pad Width (X64)	X1				0.30
Contact Pad Length (X64)	Y1				1.50
Distance Between Pads	G	0.20			

Notes:

1. Dimensioning and tolerancing per ASME Y14.5M

BSC: Basic Dimension. Theoretically exact value shown without tolerances.

Microchip Technology Drawing No. C04-2085B

dsPIC33EPXXXGM3XX/6XX/7XX

100-Lead Plastic Thin Quad Flatpack (PT) – 12x12x1 mm Body, 2.00 mm [TQFP]

Note: For the most current package drawings, please see the Microchip Packaging Specification located at <http://www.microchip.com/packaging>

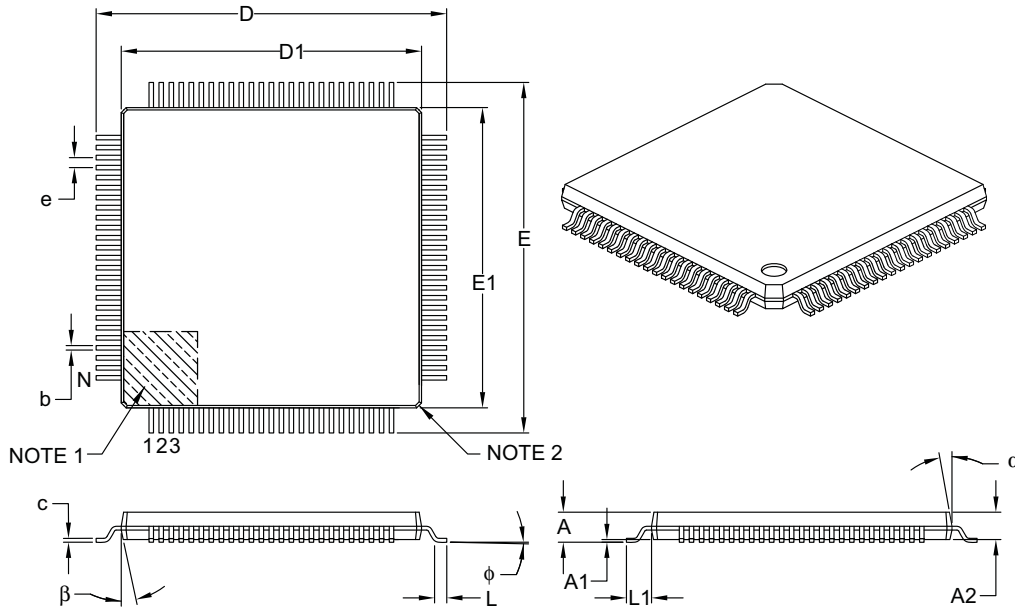

Dimension Limits	Units	MILLIMETERS		
		MIN	NOM	MAX
Number of Leads	N	100		
Lead Pitch	e	0.40 BSC		
Overall Height	A	–	–	1.20
Molded Package Thickness	A2	0.95	1.00	1.05
Standoff	A1	0.05	–	0.15
Foot Length	L	0.45	0.60	0.75
Footprint	L1	1.00 REF		
Foot Angle	ϕ	0°	3.5°	7°
Overall Width	E	14.00 BSC		
Overall Length	D	14.00 BSC		
Molded Package Width	E1	12.00 BSC		
Molded Package Length	D1	12.00 BSC		
Lead Thickness	c	0.09	–	0.20
Lead Width	b	0.13	0.18	0.23
Mold Draft Angle Top	α	11°	12°	13°
Mold Draft Angle Bottom	β	11°	12°	13°

Notes:

- Pin 1 visual index feature may vary, but must be located within the hatched area.
- Chamfers at corners are optional; size may vary.
- Dimensions D1 and E1 do not include mold flash or protrusions. Mold flash or protrusions shall not exceed 0.25 mm per side.
- Dimensioning and tolerancing per ASME Y14.5M.

BSC: Basic Dimension. Theoretically exact value shown without tolerances.

REF: Reference Dimension, usually without tolerance, for information purposes only.

Microchip Technology Drawing C04-100B

dsPIC33EPXXXGM3XX/6XX/7XX

100-Lead Plastic Thin Quad Flatpack (PT)-12x12x1mm Body, 2.00 mm Footprint [TQFP]

Note: For the most current package drawings, please see the Microchip Packaging Specification located at <http://www.microchip.com/packaging>

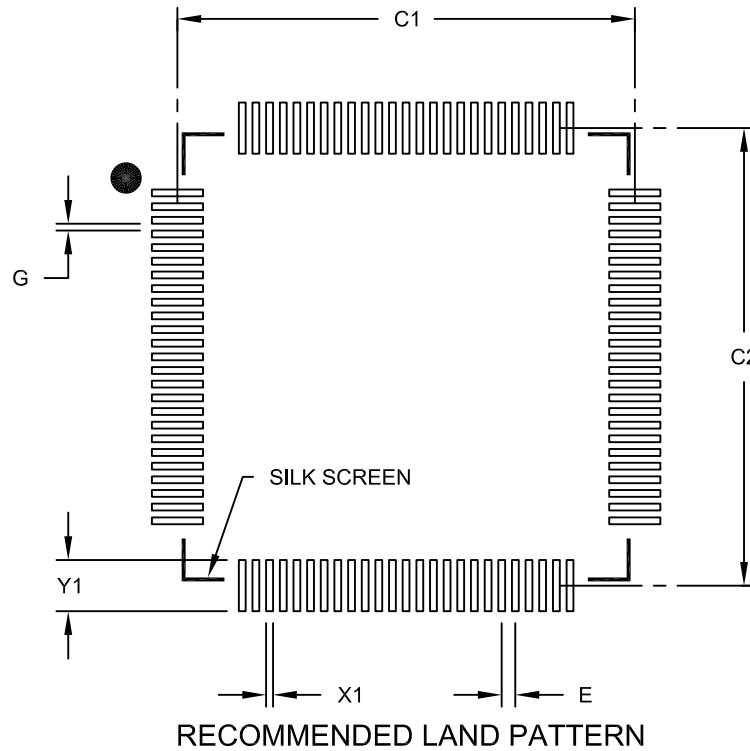

		Units	MILLIMETERS		
Dimension Limits			MIN	NOM	MAX
Contact Pitch	E		0.40 BSC		
Contact Pad Spacing	C1			13.40	
Contact Pad Spacing	C2			13.40	
Contact Pad Width (X100)	X1				0.20
Contact Pad Length (X100)	Y1				1.50
Distance Between Pads	G	0.20			

Notes:

1. Dimensioning and tolerancing per ASME Y14.5M

BSC: Basic Dimension. Theoretically exact value shown without tolerances.

Microchip Technology Drawing No. C04-2100B

dsPIC33EPXXXGM3XX/6XX/7XX

100-Lead Plastic Thin Quad Flatpack (PF) – 14x14x1 mm Body, 2.00 mm [TQFP]

Note: For the most current package drawings, please see the Microchip Packaging Specification located at <http://www.microchip.com/packaging>

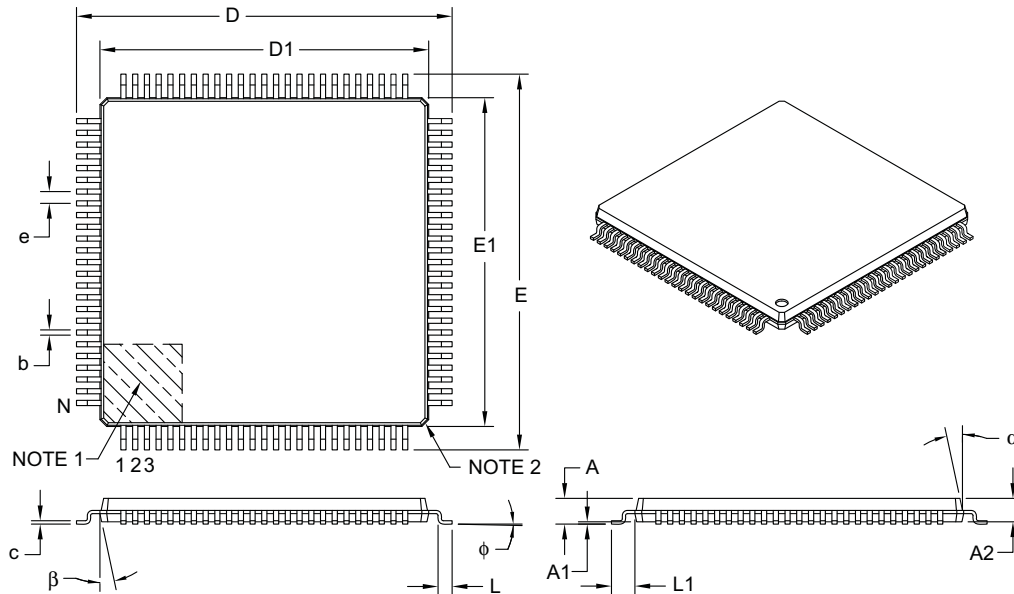

Dimension Limits	Units	MILLIMETERS		
		MIN	NOM	MAX
Number of Leads	N	100		
Lead Pitch	e	0.50 BSC		
Overall Height	A	–	–	1.20
Molded Package Thickness	A2	0.95	1.00	1.05
Standoff	A1	0.05	–	0.15
Foot Length	L	0.45	0.60	0.75
Footprint	L1	1.00 REF		
Foot Angle	ϕ	0°	3.5°	7°
Overall Width	E	16.00 BSC		
Overall Length	D	16.00 BSC		
Molded Package Width	E1	14.00 BSC		
Molded Package Length	D1	14.00 BSC		
Lead Thickness	c	0.09	–	0.20
Lead Width	b	0.17	0.22	0.27
Mold Draft Angle Top	α	11°	12°	13°
Mold Draft Angle Bottom	β	11°	12°	13°

Notes:

- Pin 1 visual index feature may vary, but must be located within the hatched area.
- Chamfers at corners are optional; size may vary.
- Dimensions D1 and E1 do not include mold flash or protrusions. Mold flash or protrusions shall not exceed 0.25 mm per side.
- Dimensioning and tolerancing per ASME Y14.5M.

BSC: Basic Dimension. Theoretically exact value shown without tolerances.

REF: Reference Dimension, usually without tolerance, for information purposes only.

Microchip Technology Drawing C04-110B

dsPIC33EPXXXGM3XX/6XX/7XX

100-Lead Plastic Thin Quad Flatpack (PF) - 14x14x1 mm Body 2.00 mm Footprint [TQFP]

Note: For the most current package drawings, please see the Microchip Packaging Specification located at <http://www.microchip.com/packaging>

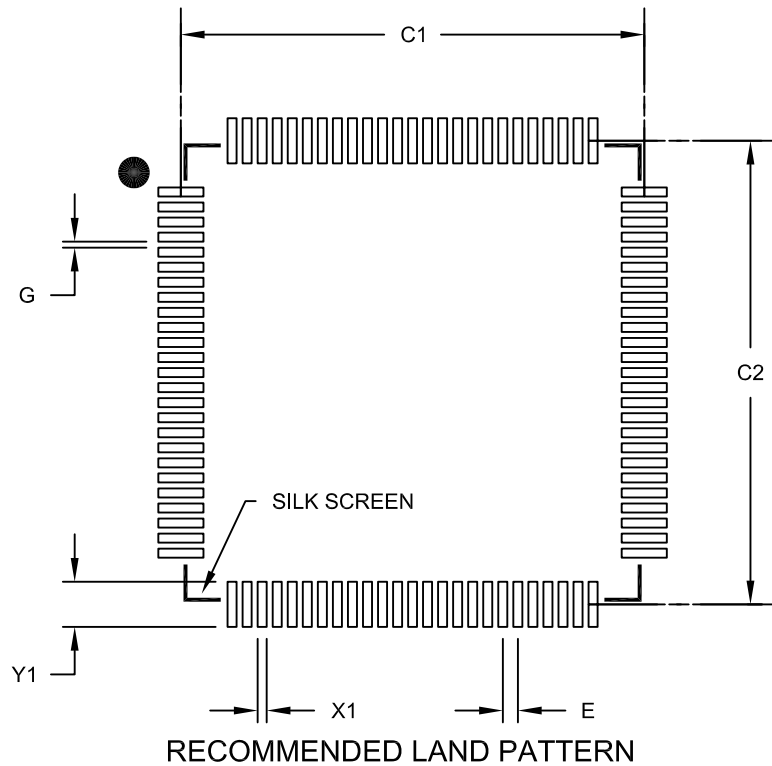

		Units	MILLIMETERS		
Dimension Limits			MIN	NOM	MAX
Contact Pitch	E		0.50 BSC		
Contact Pad Spacing	C1			15.40	
Contact Pad Spacing	C2			15.40	
Contact Pad Width (X100)	X1				0.30
Contact Pad Length (Y100)	Y1				1.50
Distance Between Pads	G	0.20			

Notes:

1. Dimensioning and tolerancing per ASME Y14.5M

BSC: Basic Dimension. Theoretically exact value shown without tolerances.

Microchip Technology Drawing No. C04-2110B

dsPIC33EPXXXGM3XX/6XX/7XX

121-Ball Plastic Thin Profile Fine Pitch Ball Grid Array (BG) - 10x10x1.10 mm Body [TFBGA]

Note: For the most current package drawings, please see the Microchip Packaging Specification located at <http://www.microchip.com/packaging>

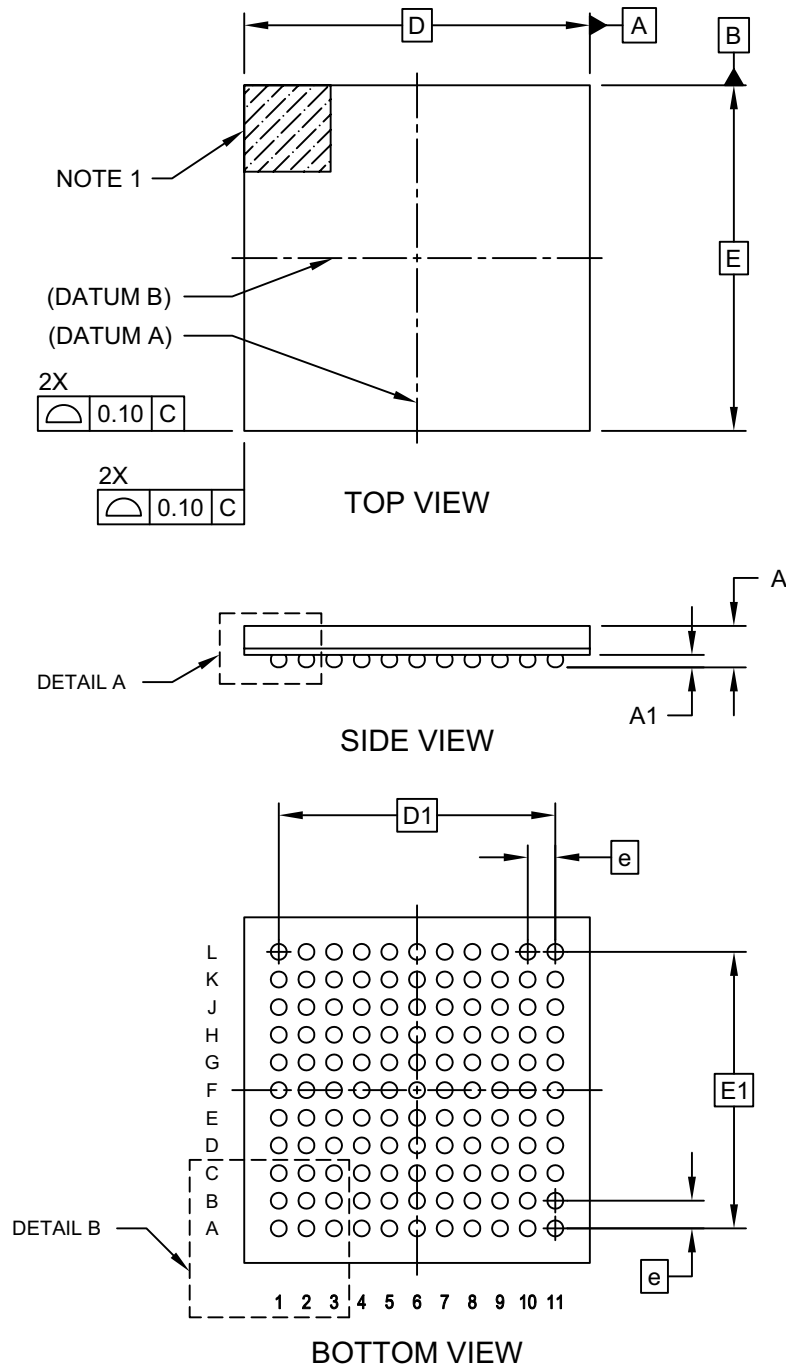

Microchip Technology Drawing C04-148 Rev F Sheet 1 of 2

121-Ball Plastic Thin Profile Fine Pitch Ball Grid Array (BG) - 10x10x1.10 mm Body [TFBGA]

Note: For the most current package drawings, please see the Microchip Packaging Specification located at <http://www.microchip.com/packaging>

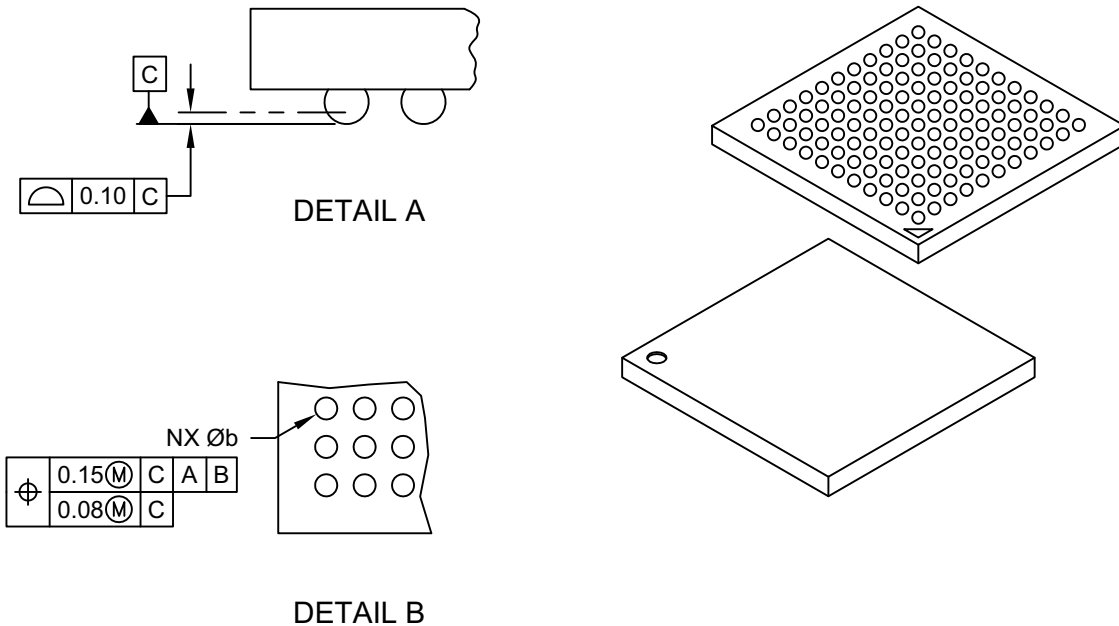

		Units	MILLIMETERS		
		Dimension Limits	MIN	NOM	MAX
Number of Contacts	N		121		
Contact Pitch	e		0.80 BSC		
Overall Height	A		1.00	1.10	1.20
Ball Height	A1		0.25	0.30	0.35
Overall Width	E		10.00 BSC		
Array Width	E1		8.00 BSC		
Overall Length	D		10.00 BSC		
Array Length	D1		8.00 BSC		
Contact Diameter	b		0.35	0.40	0.45

Notes:

- Ball A1 visual index feature may vary, but must be located within the hatched area.
- Dimensioning and tolerancing per ASME Y14.5M.
BSC: Basic Dimension. Theoretically exact value shown without tolerances.
REF: Reference Dimension, usually without tolerance, for information purposes only.
- The outer rows and columns of balls are located with respect to datums A and B.
- Ball interface to package body: 0.37mm nominal diameter.

Microchip Technology Drawing C04-148 Rev F Sheet 2 of 2

dsPIC33EPXXXGM3XX/6XX/7XX

121-Lead Plastic Thin Profile Ball Grid Array (BG) - 10x10x1.10 mm Body [TFBGA--Formerly XBGA]

Note: For the most current package drawings, please see the Microchip Packaging Specification located at <http://www.microchip.com/packaging>

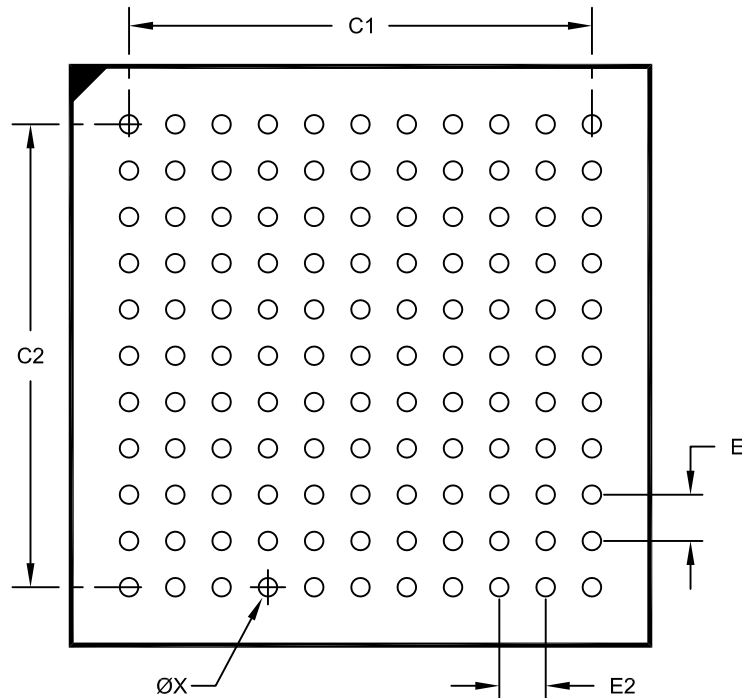

RECOMMENDED LAND PATTERN

Dimension Limits	Units	MILLIMETERS		
		MIN	NOM	MAX
Contact Pitch	E1	0.80 BSC		
Contact Pitch	E2	0.80 BSC		
Contact Pad Spacing	C1		8.00	
Contact Pad Spacing	C2		8.00	
Contact Pad Diameter (X121)	X			0.32

Notes:

1. Dimensioning and tolerancing per ASME Y14.5M

BSC: Basic Dimension. Theoretically exact value shown without tolerances.

Microchip Technology Drawing No. C04-2148 Rev D

APPENDIX A: REVISION HISTORY

Revision A (February 2013)

This is the initial released version of this document.

Revision B (June 2013)

Changes to [Section 5.0 “Flash Program Memory”](#), [Register 5-1](#). Changes to [Section 6.0 “Resets”](#), [Figure 6-1](#). Changes to [Section 26.0 “Op Amp/Comparator Module”](#), [Register 26-2](#). Updates to most of the tables in [Section 33.0 “Electrical Characteristics”](#). Minor text edits throughout the document.

Revision C (September 2013)

Changes to [Figure 23-1](#). Changes to [Figure 26-2](#). Changes to [Table 30-2](#). Changes to [Section 33.0 “Electrical Characteristics”](#). Added [Section 34.0 “High-Temperature Electrical Characteristics”](#) to the data sheet. Minor typographical edits throughout the document.

Revision D (August 2014)

This revision incorporates the following updates:

- Sections:
 - Updated [Section 2.0 “Guidelines for Getting Started with 16-Bit Digital Signal Controllers”](#), [Section 8.0 “Direct Memory Access \(DMA\)”](#), [Section 10.3 “Doze Mode”](#), [Section 21.0 “Controller Area Network \(CAN\) Module \(dsPIC33EPXXXGM6XX/7XX Devices Only\)”](#), [Section 23.0 “10-Bit/12-Bit Analog-to-Digital Converter \(ADC\)”](#), [Section 23.1.2 “12-Bit ADCx Configuration”](#), [Section 21.4 “CAN Message Buffers”](#), [Section 35.0 “Packaging Information”](#)
- Figures:
 - Updated [“Pin Diagrams”](#), [Figure 1-1](#), [Figure 9-1](#)
- Registers:
 - Updated [Register 5-1](#), [Register 8-2](#), [Register 21-1](#), [Register 23-2](#)
- Tables:
 - Updated [Table 1-1](#), [Table 7-1](#), [Table 8-1](#), [Table 34-9](#), [Table 1](#), [Table 4-2](#), [Table 4-3](#), [Table 4-25](#), [Table 4-33](#), [Table 4-34](#), [Table 4-39](#), [Table 4-30](#), [Table 4-46](#), [Table 4-47](#), [Table 33-16](#), [Table 34-8](#)

dsPIC33EPXXGM3XX/6XX/7XX

NOTES:

INDEX

A

Absolute Maximum Ratings	433
AC Characteristics	445, 503
10-Bit ADCx Conversion Requirements.....	497
12-Bit ADCx Conversion Requirements.....	495
12Cx Bus Data (Master Mode) Requirements	484
ADCx Module.....	491
ADCx Module (10-Bit Mode).....	493, 505
ADCx Module (12-Bit Mode).....	492, 505
CANx I/O Requirements	487
Capacitive Loading Requirements on	
Output Pins	445
DMA Module Requirements	498
External Clock Requirements	446
High-Speed PWMx Requirements	455
I/O Requirements	448
I2Cx Bus Data (Slave Mode) Requirements	486
Input Capture x (ICx) Requirements	453
Internal FRC Accuracy.....	447, 504
Internal LPRC Accuracy.....	447
Internal RC Accuracy	504
Load Conditions	445, 503
OCx/PWMx Mode Requirements.....	454
Op Amp/Comparator Voltage Reference	
Settling Time.....	489
Output Compare x (OCx) Requirements.....	454
PLL Clock.....	447, 504
QEIx External Clock Requirements	456
QEIx Index Pulse Requirements.....	458
Quadrature Decoder Requirements.....	457
Reset, Watchdog Timer, Oscillator Start-up Timer	
and Power-up Timer Requirements	450
SPI1 Master Mode (Full-Duplex, CKE = 0,	
CKP = x, SMP = 1) Requirements	474
SPI1 Master Mode (Full-Duplex, CKE = 1,	
CKP = x, SMP = 1) Requirements	473
SPI1 Master Mode (Half-Duplex,	
Transmit Only) Requirements	472
SPI1 Slave Mode (Full-Duplex, CKE = 0,	
CKP = 0, SMP = 0) Requirements.....	482
SPI1 Slave Mode (Full-Duplex, CKE = 0,	
CKP = 1, SMP = 0) Requirements	480
SPI1 Slave Mode (Full-Duplex, CKE = 1,	
CKP = 0, SMP = 0) Requirements	476
SPI1 Slave Mode (Full-Duplex, CKE = 1,	
CKP = 1, SMP = 0) Requirements.....	478
SPI2, SPI3 Master Mode (Full-Duplex, CKE = 0,	
CKP = x, SMP = 1) Requirements	462
SPI2, SPI3 Master Mode (Full-Duplex, CKE = 1,	
CKP = x, SMP = 1) Requirements	461
SPI2, SPI3 Master Mode (Half-Duplex,	
Transmit Only) Requirements	460
SPI2, SPI3 Slave Mode (Full-Duplex, CKE = 0,	
CKP = 0, SMP = 0) Requirements	470
SPI2, SPI3 Slave Mode (Full-Duplex, CKE = 0,	
CKP = 1, SMP = 0) Requirements	468
SPI2, SPI3 Slave Mode (Full-Duplex, CKE = 1,	
CKP = 0, SMP = 0) Requirements	464
SPI2, SPI3 Slave Mode (Full-Duplex, CKE = 1,	
CKP = 1, SMP = 0) Requirements	466
Temperature and Voltage Specifications	445
Timer1 External Clock Requirements	451

Timer2 and Timer4 (Type B) External Clock	
Requirements	452
Timer3 and Timer5 (Type C) External Clock	
Requirements	452
UARTx I/O Requirements.....	487

ADC

10-Bit Configuration.....	327
12-Bit Configuration.....	327
Control Registers.....	331
Helpful Tips.....	330
Key Features	327

Assembler

MPASM Assembler	430
-----------------------	-----

B

Bit-Reversed Addressing

Example.....	100
Implementation	99
Sequence Table (16-Entry)	100

Block Diagrams

16-Bit Timer1 Module	211
Accessing Program Memory with	
Table Instructions	102
ADCx Conversion Clock Period.....	329
ADCx with Connection Options for ANx Pins	
and Op Amps	328
Arbiter Architecture.....	95
BEMF Voltage Measured Using ADC Module.....	26
Boost Converter Implementation	24
CALL Stack Frame	96
CANx Module	296
Connections for On-Chip Voltage Regulator	416
CPU Core	28
CRC Module	405
CRC Shift Engine	406
CTMU Module	322
Data Access from Program Space	
Address Generation.....	101
DCI Module.....	343
Digital Filter Interconnect.....	367
DMA Controller	131
dsPIC33EPXXXGM3XX/6XX/7XX Devices.....	15
EDS Read Address Generation.....	90
EDS Write Address Generation.....	91
High-Speed PWMx Architectural Overview	231
High-Speed PWMx Register	
Interconnection Diagram	232
I2Cx Module	282
Input Capture x Module	219
Interleaved PFC.....	26
MCLR Pin Connections	22
Multiphase Synchronous Buck Converter	25
Multiplexing Remappable Output for RPN	171
Op Amp Configuration A.....	368
Op Amp Configuration B.....	369
Op Amp/Comparator Voltage Reference.....	366
Op Amp/Comparator x Module.....	365
Oscillator System.....	143
Output Compare x Module	223
Paged Data Memory Space	92
Peripheral to DMA Controller.....	129
PLL	144

dsPIC33EPXXXGM3XX/6XX/7XX

PMP Pinout and Connections to		
External Devices	395	
Programmer's Model	30	
PTG Module	350	
QE1x Module	258	
Recommended Minimum Connection	22	
Remappable Input for U1RX	166	
Reset System	111	
RTCC Module	384	
Shared Port Structure	163	
Single-Phase Synchronous Buck Converter	25	
SPIx Module	274	
Suggested Oscillator Circuit Placement	23	
Type B Timer (Timer2/4/6/8)	214	
Type B/Type C Timer Pair (32-Bit Timer)	215	
Type C Timer (Timer3/5/7/9)	214	
UARTx Module	289	
User-Programmable Blanking Function	367	
Watchdog Timer (WDT)	417	
Brown-out Reset (BOR)	416	
C		
C Compilers		
MPLAB XC Compilers	430	
CAN Module		
Control Registers	297	
Message Buffers	316	
Word 0	316	
Word 1	316	
Word 2	317	
Word 3	317	
Word 4	318	
Word 5	318	
Word 6	319	
Word 7	319	
Modes of Operation	296	
Overview	295	
CAN Module (CAN)	295	
Charge Time Measurement Unit (CTMU)	321	
Code Examples		
IC1 Connection to HOME1 QE11 Digital		
Filter Input on Pin 43	166	
PORTB Write/Read	164	
PWM1 Write-Protected Register		
Unlock Sequence	230	
PWRSAV Instruction Syntax	153	
Code Protection	411, 418	
CodeGuard Security	411, 418	
Configuration Bits	411	
Description	413	
CPU	27	
Addressing Modes	27	
Arithmetic Logic Unit (ALU)	35	
Control Registers	31	
Data Space Addressing	27	
DSP Engine	35	
Instruction Set	27	
Programmer's Model	29	
Register Descriptions	29	
CTMU		
Control Registers	323	
Customer Change Notification Service	536	
Customer Notification Service	536	
Customer Support	536	
D		
Data Address Space	41	
Memory Map for 128-Kbyte Devices	42	
Memory Map for 256-Kbyte Devices	43	
Memory Map for 512-Kbyte Devices	44	
Near Data Space	41	
Organization and Alignment	41	
SFR Space	41	
Width	41	
Data Converter Interface (DCI) Module	343	
Data Memory		
Arbitration and Bus Master Priority	95	
DC Characteristics	434	
Brown-out Reset (BOR)	443	
CTMU Current Source	490	
Doze Current (IDOZE)	439, 501	
Filter Capacitor (CEFC) Specifications	435	
High Temperature	500	
I/O Pin Input Specifications	440	
I/O Pin Output Specifications	443, 502	
Idle Current (IDLE)	437, 501	
Op Amp/Comparator Specifications	488	
Op Amp/Comparator Voltage		
Reference Specifications	489	
Operating Current (IDD)	436, 501	
Operating MIPS vs. Voltage	434, 500	
Power-Down Current (IPD)	438, 500	
Program Memory	444, 502	
Temperature and Voltage	500	
Temperature and Voltage Specifications	435	
Thermal Operating Conditions	434, 500	
Thermal Packaging Characteristics	434	
DCI		
Control Registers	344	
Introduction	343	
Demo/Development Boards, Evaluation		
and Starter Kits	432	
Development Support	429	
Third-Party Tools	432	
DMA Controller		
Channel to Peripheral Associations	130	
Control Registers	132	
DMAxCNT	132	
DMAxCON	132	
DMAxPAD	132	
DMAxREQ	132	
DMAxSTAL/H	132	
DMAxSTBL/H	132	
Supported Peripherals	129	
Doze Mode	155	
E		
Electrical Characteristics	433	
AC	445, 503	
Equations		
Device Operating Frequency	144	
Fosc Calculation	144	
Fvco Calculation	144	
Errata	12	

dsPIC33EPXXXGM3XX/6XX/7XX

F		
Flash Program Memory	103	
Control Registers	104	
Operations	104	
RTSP Operation.....	104	
Table Instructions.....	103	
Flexible Configuration	411	
G		
Getting Started with 16-Bit DSCs.....	21	
Connection Requirements	21	
CPU Logic Filter Capacitor Connection (VCAP)	22	
Decoupling Capacitors.....	21	
External Oscillator Pins.....	23	
ICSP Pins.....	23	
Master Clear (MCLR) Pin.....	22	
Oscillator Value Conditions on Device Start-up	24	
Unused I/Os	24	
H		
High-Speed PWM	229	
Control Registers	233	
Faults	229	
High-Temperature Electrical Characteristics.....	499	
Absolute Maximum Ratings	499	
High-Voltage Detect (HVD).....	173	
I		
I/O Ports	163	
Configuring Analog/Digital Port Pins.....	164	
Helpful Tips.....	173	
Open-Drain Configuration	164	
Parallel I/O (PIO).....	163	
Write/Read Timing	164	
In-Circuit Debugger.....	418	
In-Circuit Emulation.....	411	
In-Circuit Serial Programming (ICSP)	411, 418	
Input Capture	219	
Control Registers	220	
Input Change Notification (ICN)	164	
Instruction Addressing Modes.....	96	
File Register Instructions	96	
Fundamental Modes Supported.....	97	
MAC Instructions.....	97	
MCU Instructions	96	
Move and Accumulator Instructions	97	
Other Instructions.....	97	
Instruction Set		
Overview	422	
Summary.....	419	
Interfacing Program and Data Memory Spaces.....	101	
Inter-Integrated Circuit (I ² C).....	281	
Control Registers	283	
Internal LPRC Oscillator		
Use with WDT	417	
Internet Address.....	536	
Interrupt Controller		
Control and Status Registers	120	
IECx	120	
IFSx	120	
INTCON1	120	
INTCON2	120	
INTCON3	120	
INTCON4	120	
INTTREG	120	
IPCx	120	
Reset Sequence	115	
Interrupt Vector		
Details (table)	117	
Interrupt Vector Table (IVT).....	115	
Interrupt Vector Table (table).....	116	
J		
JTAG Boundary Scan Interface.....	411	
JTAG Interface	418	
M		
Memory Maps		
EDS	94	
Memory Organization	37	
Microchip Internet Web Site.....	536	
Modulo Addressing	98	
Applicability.....	99	
Operation Example.....	98	
Start and End Address	98	
W Address Register Selection.....	98	
MPLAB Assembler, Linker, Librarian.....	430	
MPLAB ICD 3 In-Circuit Debugger	431	
MPLAB PM3 Device Programmer	431	
MPLAB REAL ICE In-Circuit Emulator System	431	
MPLAB X Integrated Development		
Environment Software	429	
MPLAB X SIM Software Simulator	431	
MPLIB Object Librarian.....	430	
MPLINK Object Linker	430	
O		
Op Amp		
Application Considerations	368	
Configuration A.....	368	
Configuration B.....	369	
Op Amp/Comparator.....	365	
Control Registers.....	370	
Resources	369	
Oscillator Configuration	143	
CPU Clocking System	144	
Output Compare	223	
Control Registers.....	224	
P		
Packaging	507	
Details.....	517, 518	
Marking.....	507, 508	
Parallel Master Port (PMP).....	395	
Peripheral Module Disable (PMD)	155	
Peripheral Pin Select (PPS).....	165	
Input Sources, Maps Input to Function.....	167	
Output Selection for Remappable Pins	172	
Peripheral Trigger Generator (PTG) Module	349	
PICkit 3 In-Circuit Debugger/Programmer.....	431	
Pinout I/O Descriptions (table).....	16	
PMP		
Control Registers.....	396	
Power-Saving Features	153	
Clock Frequency and Switching	153	
Instruction-Based Modes	153	
Idle.....	154	
Sleep	154	
Interrupts Coincident with Power Save		
Instructions	154	
PPS		
Control Registers.....	175	

dsPIC33EPXXXGM3XX/6XX/7XX

Program Address Space	37	Peripheral Pin Select Input (dsPIC33EPGM60X/7XX Devices)	76
Memory Map for dsPIC33EP128GM3XX/6XX/7XX Devices	37	Peripheral Pin Select Input (dsPIC33EPXXXGM3XX Devices)	77
Memory Map for dsPIC33EP256GM3XX/6XX/7XX Devices	38	Peripheral Pin Select Output (dsPIC33EPXXXGM304/604 Devices)	74
Memory Map for dsPIC33EP512GM3XX/6XX/7XX Devices	39	Peripheral Pin Select Output (dsPIC33EPXXXGM306/706 Devices)	74
Program Memory		Peripheral Pin Select Output (dsPIC33EPXXXGM310/710 Devices)	75
Organization	40	PMD (dsPIC33EPXXXGM3XX Devices)	80
Reset Vector	40	PMD (dsPIC33EPXXXGM6XX/7XX Devices)	79
Program Space		PORTA (dsPIC33EPXXXGM304/604 Devices)	84
Address Construction	101	PORTA (dsPIC33EPXXXGM306/706 Devices)	84
Data Access from Program Memory Using Table Instructions	102	PORTA (dsPIC33EPXXXGM310/710 Devices)	84
Table Read Instructions TBLRDH	102	PORTB (dsPIC33EPXXXGM304/604 Devices)	85
TBLRDL	102	PORTB (dsPIC33EPXXXGM306/706 Devices)	85
Table Read Instructions TBLRDL	102	PORTB (dsPIC33EPXXXGM310/710 Devices)	85
Programmable CRC		PORTC (dsPIC33EPXXXGM304/604 Devices)	86
Control Registers	407	PORTC (dsPIC33EPXXXGM306/706 Devices)	86
Overview	406	PORTC (dsPIC33EPXXXGM310/710 Devices)	86
Setup Examples	406	PORTD (dsPIC33EPXXXGM306/706 Devices)	87
Programmable Cyclic Redundancy Check (CRC)		PORTD (dsPIC33EPXXXGM310/710 Devices)	87
Generator	405	PORTE (dsPIC33EPXXXGM306/706 Devices)	88
PTG		PORTE (dsPIC33EPXXXGM310/710 Devices)	87
Control Registers	351	PORTF (dsPIC33EPXXXGM306/706 Devices)	88
Introduction	349	PORTF (dsPIC33EPXXXGM310/710 Devices)	88
Output Descriptions	364	PORTG (dsPIC33EPXXXGM306/706 Devices)	89
Step Commands and Format	361	PORTG (dsPIC33EPXXXGM310/710 Devices)	89
Q		Programmable CRC	73
Quadrature Encoder Interface (QE1)	257	PTG	56
Control Registers	259	PWM	57
R		PWM Generator 1	57
Real-Time Clock and Calendar (RTCC)	383	PWM Generator 2	58
Referenced Sources	13	PWM Generator 3	58
Register		PWM Generator 4	59
PTGADJ (PTG Adjust)	359	PWM Generator 5	59
PTGL0 (PTG Literal 0)	359	PWM Generator 6	60
PTGQPTR (PTG Step Queue Pointer)	360	QE1	61
PTGQUEX (PTG Step Queue x)	360	QE2	62
Register Maps		Real-Time Clock and Calendar	82
ADC1 and ADC2	66	Reference Clock	78
CAN1 (When WIN (C1CTRL) = 0 or 1)	68	SPI1, SPI2 and SPI3	64
CAN1 (When WIN (C1CTRL) = 0)	68	System Control	78
CAN1 (When WIN (C1CTRL) = 1)	69	Timers	52
CAN2 (When WIN (C1CTRL) = 0 or 1)	70	UART1 and UART2	63
CAN2 (When WIN (C1CTRL) = 0)	71	UART3 and UART4	64
CAN2 (When WIN (C1CTRL) = 1)	72	Registers	
Configuration Byte	412	ADxCHS0 (ADCx Input Channel 0 Select)	338
CPU Core	46	ADxCHS123 (ADCx Input Channel 1, 2, 3 Select)	337
CTMU	82	ADxCON1 (ADCx Control 1)	331
DCI	65	ADxCON2 (ADCx Control 2)	333
DMA Controller	83	ADxCON3 (ADCx Control 3)	335
I2C1 and I2C2	63	ADxCON4 (ADCx Control 4)	336
Input Capture 1-8	53	ADxCSSH (ADCx Input Scan Select High)	340
Interrupt Controller (dsPIC33EPXXXGM3XX Devices)	50	ADxCSSL (ADCx Input Scan Select Low)	342
Interrupt Controller (dsPIC33EPXXXGM6XX/7XX Devices)	48	ALCFGRPT (Alarm Configuration)	388
JTAG Interface	82	ALRMVAL (Alarm Minutes and Seconds Value, ALRMPTR = 00)	393
NVM	78	ALRMVAL (Alarm Month and Day Value, ALRMPTR = 10)	391
Op Amp/Comparator	81	ALRMVAL (Alarm Weekday and Hours Value, ALRMPTR = 01)	392
Output Compare	54	ALTDTRx (PWMx Alternate Dead-Time)	246
Pad Configuration	89		
Parallel Master/Slave Port	79		

dsPIC33EPXXXGM3XX/6XX/7XX

AUXCONx (PWMx Auxiliary Control).....	254	DEVREV (Device Revision).....	415
CHOP (PWMx Chop Clock Generator).....	241	DMALCA (DMA Last Channel Active Status).....	140
CLKDIV (Clock Divisor).....	148	DMAPPS (DMA Ping-Pong Status).....	141
CM4CON (Op Amp/Comparator 4 Control).....	373	DMA PWC (DMA Peripheral Write Collision Status).....	138
CMSTAT (Op Amp/Comparator Status).....	370	DMARQC (DMA Request Collision Status).....	139
CMxCON (Op Amp/Comparator x Control, x = 1, 2, 3 or 5).....	371	DMAxCNT (DMA Channel x Transfer Count).....	136
CMxFLTR (Comparator x Filter Control).....	379	DMAxCON (DMA Channel x Control).....	132
CMxMSKCON (Comparator x Mask Gating Control).....	377	DMAxPAD (DMA Channel x Peripheral Address).....	136
CMxMSKSR (Comparator x Mask Source Select Control).....	375	DMAxREQ (DMA Channel x IRQ Select).....	133
CORCON (Core Control).....	33, 122	DMAxSTAH (DMA Channel x Start Address A, High).....	134
CRCCON1 (CRC Control 1).....	407	DMAxSTAL (DMA Channel x Start Address A, Low).....	134
CRCCON2 (CRC Control 2).....	408	DMAxSTBH (DMA Channel x Start Address B, High).....	135
CRCXORH (CRC XOR Polynomial High).....	409	DMAxSTBL (DMA Channel x Start Address B, Low).....	135
CRCXORL (CRC XOR Polynomial Low).....	409	DSADRH (DMA Most Recent RAM High Address).....	137
CTMUCON1 (CTMU Control Register 1).....	323	DSADRL (DMA Most Recent RAM Low Address).....	137
CTMUCON2 (CTMU Control Register 2).....	324	DTRx (PWMx Dead-Time).....	246
CTMUICON (CTMU Current Control).....	326	FCLCONx (PWMx Fault Current-Limit Control).....	250
CVR1CON (Comparator Voltage Reference Control 1).....	380	I2CxCON (I2Cx Control).....	283
CVR2CON (Comparator Voltage Reference Control 2).....	381	I2CxMSK (I2Cx Slave Mode Address Mask).....	287
CxBUFPNT1 (CANx Filters 0-3 Buffer Pointer 1).....	306	I2CxSTAT (I2Cx Status).....	285
CxBUFPNT2 (CANx Filters 4-7 Buffer Pointer 2).....	307	ICxCON1 (Input Capture x Control 1).....	220
CxBUFPNT3 (CANx Filters 8-11 Buffer Pointer 3).....	307	ICxCON2 (Input Capture x Control 2).....	221
CxBUFPNT4 (CANx Filters 12-15 Buffer Pointer 4).....	308	INDXxCNTH (Index Counter x High Word).....	267
CxCFG1 (CANx Baud Rate Configuration 1).....	304	INDXxCNTL (Index Counter x Low Word).....	267
CxCFG2 (CANx Baud Rate Configuration 2).....	305	INDXxHLD (Index Counter x Hold).....	268
CxCTRL1 (CANx Control 1).....	297	INTCON1 (Interrupt Control 1).....	123
CxCTRL2 (CANx Control 2).....	298	INTCON2 (Interrupt Control 2).....	125
CxEC (CANx Transmit/Receive Error Count).....	304	INTCON3 (Interrupt Control 3).....	126
CxFCTRL (CANx FIFO Control).....	300	INTCON4 (Interrupt Control 4).....	126
CxFEN1 (CANx Acceptance Filter Enable 1).....	306	INTTREG (Interrupt Control and Status).....	127
CxFIFO (CANx FIFO Status).....	301	INTxHLDH (Interval Timerx Hold High Word).....	272
CxFMSKSEL1 (CANx Filters 7-0 Mask Selection 1).....	310	INTxHLDL (Interval Timerx Hold Low Word).....	272
CxFMSKSEL2 (CANx Filters 15-8 Mask Selection 2).....	311	INTxTMRH (Interval Timerx High Word).....	271
CxINTE (CANx Interrupt Enable).....	303	INTxTMRL (Interval Timerx Low Word).....	271
CxINTF (CANx Interrupt Flag).....	302	IOCONx (PWMx I/O Control).....	248
CxRXFnEID (CANx Acceptance Filter n Extended Identifier).....	309	LEBCONx (Leading-Edge Blanking Control x).....	252
CxRXFnSID (CANx Acceptance Filter n Standard Identifier).....	309	LEBDLYx (Leading-Edge Blanking Delay x).....	253
CxRXFUL1 (CANx Receive Buffer Full 1).....	313	MDC (PWMx Master Duty Cycle).....	241
CxRXFUL2 (CANx Receive Buffer Full 2).....	313	NVMADR (Nonvolatile Memory Lower Address).....	107
CxRXMnEID (CANx Acceptance Filter Mask n Extended Identifier).....	312	NVMADRU (Nonvolatile Memory Upper Address).....	107
CxRXMnSID (CANx Acceptance Filter Mask n Standard Identifier).....	312	NVMCON (Nonvolatile Memory (NVM) Control).....	105
CxRXOVF1 (CANx Receive Buffer Overflow 1).....	314	NVMKEY (Nonvolatile Memory Key).....	108
CxRXOVF2 (CANx Receive Buffer Overflow 2).....	314	NVMSRCADRH (Nonvolatile Data Memory Upper Address).....	108
CxTRMnCON (CANx TX/RX Buffer mn Control).....	315	NVMSRCADRL (Nonvolatile Data Memory Lower Address).....	109
CxVEC (CANx Interrupt Code).....	299	OCxCON1 (Output Compare x Control 1).....	224
DCICON1 (DCI Control 1).....	344	OCxCON2 (Output Compare x Control 2).....	226
DCICON2 (DCI Control 2).....	345	OSCCON (Oscillator Control).....	146
DCICON3 (DCI Control 3).....	346	OSCTUN (FRC Oscillator Tuning).....	151
DCISTAT (DCI Status).....	347	PADCFG1 (Pad Configuration Control).....	387, 403
DEVID (Device ID).....	415	PDCx (PWMx Generator Duty Cycle).....	244
		PHASEx (PWMx Primary Phase-Shift).....	245
		PLLFBD (PLL Feedback Divisor).....	150
		PMADDR (Parallel Master Port Address).....	400
		PMAEN (Parallel Master Port Address Enable).....	401

dsPIC33EPXXGM3XX/6XX/7XX

PMCON (Parallel Master Port Control)	396	RPINR25 (Peripheral Pin Select Input 25).....	192
PMD1 (Peripheral Module Disable Control 1).....	156	RPINR26 (Peripheral Pin Select Input 26).....	193
PMD2 (Peripheral Module Disable Control 2).....	158	RPINR27 (Peripheral Pin Select Input 27).....	194
PMD3 (Peripheral Module Disable Control 3).....	159	RPINR28 (Peripheral Pin Select Input 28).....	195
PMD4 (Peripheral Module Disable Control 4).....	161	RPINR29 (Peripheral Pin Select Input 29).....	196
PMD6 (Peripheral Module Disable Control 6).....	161	RPINR3 (Peripheral Pin Select Input 3).....	177
PMD7 (Peripheral Module Disable Control 7).....	162	RPINR30 (Peripheral Pin Select Input 30).....	197
PMODE (Parallel Master Port Mode).....	398	RPINR37 (Peripheral Pin Select Input 37).....	198
PMSTAT (Parallel Master Port Status).....	402	RPINR38 (Peripheral Pin Select Input 38).....	199
POSxCNTH (Position Counter x High Word).....	265	RPINR39 (Peripheral Pin Select Input 39).....	200
POSxCNTL (Position Counter x Low Word).....	265	RPINR40 (Peripheral Pin Select Input 40).....	201
POSxHLD (Position Counter x Hold).....	266	RPINR41 (Peripheral Pin Select Input 41).....	202
PTCON (PWMx Time Base Control).....	233	RPINR7 (Peripheral Pin Select Input 7).....	178
PTCON2 (PWMx Primary Master Clock Divider Select 2).....	235	RPINR8 (Peripheral Pin Select Input 8).....	179
PTGBTE (PTG Broadcast Trigger Enable).....	354	RPINR9 (Peripheral Pin Select Input 9).....	180
PTGC0LIM (PTG Counter 0 Limit).....	357	RPOR0 (Peripheral Pin Select Output 0).....	203
PTGC1LIM (PTG Counter 1 Limit).....	358	RPOR1 (Peripheral Pin Select Output 1).....	203
PTGCON (PTG Control).....	353	RPOR10 (Peripheral Pin Select Output 10).....	208
PTGCST (PTG Control/Status).....	351	RPOR11 (Peripheral Pin Select Output 11).....	208
PTGHOLD (PTG Hold).....	358	RPOR12 (Peripheral Pin Select Output 12).....	209
PTGSDLIM (PTG Step Delay Limit).....	357	RPOR2 (Peripheral Pin Select Output 2).....	204
PTGT0LIM (PTG Timer0 Limit).....	356	RPOR3 (Peripheral Pin Select Output 3).....	204
PTGT1LIM (PTG Timer1 Limit).....	356	RPOR4 (Peripheral Pin Select Output 4).....	205
PTPER (PWMx Primary Master Time Base Period).....	236	RPOR5 (Peripheral Pin Select Output 5).....	205
PWMCAPx (PWMx Primary Time Base Capture).....	255	RPOR6 (Peripheral Pin Select Output 6).....	206
PWMCONx (PWMx Control).....	242	RPOR7 (Peripheral Pin Select Output 7).....	206
QEIXCON (QEIX Control).....	259	RPOR8 (Peripheral Pin Select Output 8).....	207
QEIXGECH (QEIX Greater Than or Equal Compare High Word).....	270	RPOR9 (Peripheral Pin Select Output 9).....	207
QEIXGECL (QEIX Greater Than or Equal Compare Low Word).....	270	RSCON (DCI Receive Slot Control).....	348
QEIXICH (QEIX Initialization/Capture High Word).....	268	RTCVAL (Minutes and Seconds Value, RTCPTTR = 00).....	390
QEIXICL (QEIX Initialization/Capture Low Word).....	268	RTCVAL (Month and Day Value, RTCPTTR = 10).....	389
QEIXIOC (QEIX I/O Control).....	261	RTCVAL (Weekday and Hours Value, RTCPTTR = 01).....	390
QEIXLECH (QEIX Less Than or Equal Compare High Word).....	269	RTCVAL (Year Value, RTCPTTR = 11).....	389
QEIXLECL (QEIX Less Than or Equal Compare Low Word).....	269	SDCx (PWMx Secondary Duty Cycle).....	244
QEIXSTAT (QEIX Status).....	263	SEVTCMP (PWMx Primary Special Event Compare).....	236
RCFGCAL (RTCC Calibration and Configuration).....	386	SPHASEx (PWMx Secondary Phase-Shift).....	245
RCON (Reset Control).....	112	SPIxCON1 (SPIx Control 1).....	278
REFOCON (Reference Oscillator Control).....	152	SPIxCON2 (SPIx Control 2).....	280
RPINR0 (Peripheral Pin Select Input 0).....	175	SPIxSTAT (SPIx Status and Control).....	276
RPINR1 (Peripheral Pin Select Input 1).....	176	SR (CPU STATUS).....	31, 121
RPINR10 (Peripheral Pin Select Input 10).....	181	SSEVTCMP (PWMx Secondary Special Event Compare).....	240
RPINR11 (Peripheral Pin Select Input 11).....	182	STCON (PWMx Secondary Time Base Control).....	237
RPINR12 (Peripheral Pin Select Input 12).....	183	STCON2 (PWMx Secondary Master Clock Divider Select 2).....	239
RPINR14 (Peripheral Pin Select Input 14).....	184	STPER (PWMx Secondary Master Time Base Period).....	240
RPINR15 (Peripheral Pin Select Input 15).....	185	T1CON (Timer1 Control).....	212
RPINR16 (Peripheral Pin Select Input 16).....	186	TRGCONx (PWMx Trigger Control).....	247
RPINR17 (Peripheral Pin Select Input 17).....	187	TRIGx (PWMx Primary Trigger Compare Value).....	249
RPINR18 (Peripheral Pin Select Input 18).....	188	TSCON (DCI Transmit Slot Control).....	348
RPINR19 (Peripheral Pin Select Input 19).....	188	TxCON (T2CON, T4CON, T6CON and T8CON Control).....	216
RPINR22 (Peripheral Pin Select Input 22).....	189	TyCON (T3CON, T5CON, T7CON and T9CON Control).....	217
RPINR23 (Peripheral Pin Select Input 23).....	190	UxMODE (UARTx Mode).....	291
RPINR24 (Peripheral Pin Select Input 24).....	191	UxSTA (UARTx Status and Control).....	293
		VELxCNT (Velocity Counter x).....	266

dsPIC33EPXXXGM3XX/6XX/7XX

Resets	111	Power-on Reset Characteristics	449
Brown-out Reset (BOR)	111	QEAx/QEBx Input	457
Configuration Mismatch Reset (CM)	111	QEIx Index Pulse	458
Illegal Condition Reset (IOPUWR)	111	SPI1 Master Mode (Full-Duplex, CKE = 0, CKP = x, SMP = 1)	474
Illegal Address Mode	111	SPI1 Master Mode (Full-Duplex, CKE = 1, CKP = x, SMP = 1)	473
Illegal Opcode	111	SPI1 Master Mode (Half-Duplex, Transmit Only, CKE = 0)	471
Security	111	SPI1 Master Mode (Half-Duplex, Transmit Only, CKE = 1)	472
Uninitialized W Register	111	SPI1 Slave Mode (Full-Duplex, CKE = 0, CKP = 0, SMP = 0)	481
Master Clear Pin Reset (MCLR)	111	SPI1 Slave Mode (Full-Duplex, CKE = 0, CKP = 1, SMP = 0)	479
Master Reset Signal (SYSRST)	111	SPI1 Slave Mode (Full-Duplex, CKE = 1, CKP = 0, SMP = 0)	475
Power-on Reset (POR)	111	SPI1 Slave Mode (Full-Duplex, CKE = 1, CKP = 1, SMP = 0)	477
RESET Instruction (SWR)	111	SPI2, SPI3 Master Mode (Full-Duplex, CKE = 0, CKP = x, SMP = 1)	462
Trap Conflict Reset (TRAPR)	111	SPI2, SPI3 Master Mode (Full-Duplex, CKE = 1, CKP = x, SMP = 1)	461
Watchdog Timer Time-out Reset (WDTO)	111	SPI2, SPI3 Master Mode (Half-Duplex, Transmit Only, CKE = 0)	459
Revision History	527	SPI2, SPI3 Master Mode (Half-Duplex, Transmit Only, CKE = 1)	460
RTCC		SPI2, SPI3 Slave Mode (Full-Duplex, CKE = 0, CKP = 0, SMP = 0)	469
Control Registers	386	SPI2, SPI3 Slave Mode (Full-Duplex, CKE = 0, CKP = 1, SMP = 0)	467
Resources	385	SPI2, SPI3 Slave Mode (Full-Duplex, CKE = 1, CKP = 0, SMP = 0)	463
Writing to the Timer	385	SPI2, SPI3 Slave Mode (Full-Duplex, CKE = 1, CKP = 1, SMP = 0)	465
S		Timer1-Timer5 External Clock	451
Serial Peripheral Interface (SPI)	273	TimerQ (QEIx Module) External Clock	456
Special Features of the CPU	411	UARTx I/O	487
SPI		Timing Specifications	
Control Registers	276	I2Cx Bus Data Requirements (Master Mode)	484
Helpful Tips	275	I2Cx Bus Data Requirements (Slave Mode)	486
Symbols Used in Opcode Descriptions	420	U	
T		UART	
Temperature and Voltage Specifications		Control Registers	291
AC	503	Helpful Tips	290
Timer		Universal Asynchronous Receiver Transmitter (UART)	289
Control Registers	216	User ID Words	416
Timer1	211	V	
Control Register	212	Voltage Regulator (On-Chip)	416
Timer2/3, Timer4/5, Timer6/7 and Timer8/9	213	W	
Timing Diagrams		Watchdog Timer (WDT)	411, 417
10-Bit ADC1 Conversion (CHPS<1:0> = 01, SIMSAM = 0, ASAM = 0, SSRCS<2:0> = 000, SSRCG = 0)	496	Programming Considerations	417
10-Bit ADC1 Conversion (CHPS<1:0> = 01, SIMSAM = 0, ASAM = 1, SSRCS<2:0> = 111, SSRCG = 0, SAMC<4:0> = 00010)	496	WWW Address	536
12-Bit ADC1 Conversion (ASAM = 0, SSRC<2:0> = 000, SSRCG = 0)	494	WWW, On-Line Support	12
BOR and Master Clear Reset	448		
CANx I/O	487		
External Clock	446		
High-Speed PWMx	455		
High-Speed PWMx Fault	455		
I/O Characteristics	448		
I2Cx Bus Data (Master Mode)	483		
I2Cx Bus Data (Slave Mode)	485		
I2Cx Bus Start/Stop Bits (Master Mode)	483		
I2Cx Bus Start/Stop Bits (Slave Mode)	485		
Input Capture x (ICx)	453		
Load Conditions	490		
OCx/PWMx	454		
Output Compare x (OCx)	454		

dsPIC33EPXXGM3XX/6XX/7XX

NOTES:

THE MICROCHIP WEB SITE

Microchip provides online support via our WWW site at www.microchip.com. This web site is used as a means to make files and information easily available to customers. Accessible by using your favorite Internet browser, the web site contains the following information:

- **Product Support** – Data sheets and errata, application notes and sample programs, design resources, user's guides and hardware support documents, latest software releases and archived software
- **General Technical Support** – Frequently Asked Questions (FAQ), technical support requests, online discussion groups, Microchip consultant program member listing
- **Business of Microchip** – Product selector and ordering guides, latest Microchip press releases, listing of seminars and events, listings of Microchip sales offices, distributors and factory representatives

CUSTOMER CHANGE NOTIFICATION SERVICE

Microchip's customer notification service helps keep customers current on Microchip products. Subscribers will receive e-mail notification whenever there are changes, updates, revisions or errata related to a specified product family or development tool of interest.

To register, access the Microchip web site at www.microchip.com. Under "Support", click on "Customer Change Notification" and follow the registration instructions.

CUSTOMER SUPPORT

Users of Microchip products can receive assistance through several channels:

- Distributor or Representative
- Local Sales Office
- Field Application Engineer (FAE)
- Technical Support

Customers should contact their distributor, representative or Field Application Engineer (FAE) for support. Local sales offices are also available to help customers. A listing of sales offices and locations is included in the back of this document.

Technical support is available through the web site at: <http://microchip.com/support>

dsPIC33EPXXXGM3XX/6XX/7XX

NOTES:

PRODUCT IDENTIFICATION SYSTEM

To order or obtain information, e.g., on pricing or delivery, refer to the factory or the listed sales office.

<p style="text-align: center;">dsPIC 33 EP 512 GM7 10 T - I / PT XXX</p> <p>Microchip Trademark _____</p> <p>Architecture _____</p> <p>Core Family _____</p> <p>Program Memory Size (Kbytes) _____</p> <p>Product Group _____</p> <p>Pin Count _____</p> <p>Tape and Reel Flag (if applicable) _____</p> <p>Temperature Range _____</p> <p>Package _____</p> <p>Pattern _____</p>		<p>Example:</p> <p>dsPIC33EP512GM710-I/PT: dsPIC33, Enhanced Performance, 512-Kbyte program memory, 100-pin, Industrial temperature, TQFP package.</p>
<p>Architecture: 33 = 16-Bit Digital Signal Controller</p> <p>Family: EP = Enhanced Performance</p> <p>Product Group: GM7 = General Purpose plus Motor Control Family</p> <p>Pin Count: 04 = 44-pin 06 = 64-pin 10 = 100/124-pin</p> <p>Temperature Range: I = -40°C to +85°C (Industrial) E = -40°C to +125°C (Extended)</p> <p>Package: BG = Plastic Thin Profile Ball Grid Array - (121-pin) 10x10 mm body (TFBGA) ML = Plastic Quad, No Lead Package - (44-pin) 8x8 mm body (QFN) MR = Plastic Quad, No Lead Package - (64-pin) 9x9 mm body (QFN) PT = Plastic Thin Quad Flatpack - (44-pin) 10x10 mm body (TQFP) PT = Plastic Thin Quad Flatpack - (64-pin) 10x10 mm body (TQFP) PT = Thin Quad Flatpack - (100-pin) 12x12x1 mm body (TQFP) PF = Thin Quad Flatpack - (100-pin) 14x14x1 mm body (TQFP)</p>		

dsPIC33EPXXGM3XX/6XX/7XX

NOTES:

Note the following details of the code protection feature on Microchip devices:

- Microchip products meet the specification contained in their particular Microchip Data Sheet.
- Microchip believes that its family of products is one of the most secure families of its kind on the market today, when used in the intended manner and under normal conditions.
- There are dishonest and possibly illegal methods used to breach the code protection feature. All of these methods, to our knowledge, require using the Microchip products in a manner outside the operating specifications contained in Microchip's Data Sheets. Most likely, the person doing so is engaged in theft of intellectual property.
- Microchip is willing to work with the customer who is concerned about the integrity of their code.
- Neither Microchip nor any other semiconductor manufacturer can guarantee the security of their code. Code protection does not mean that we are guaranteeing the product as “unbreakable.”

Code protection is constantly evolving. We at Microchip are committed to continuously improving the code protection features of our products. Attempts to break Microchip's code protection feature may be a violation of the Digital Millennium Copyright Act. If such acts allow unauthorized access to your software or other copyrighted work, you may have a right to sue for relief under that Act.

Information contained in this publication regarding device applications and the like is provided only for your convenience and may be superseded by updates. It is your responsibility to ensure that your application meets with your specifications. MICROCHIP MAKES NO REPRESENTATIONS OR WARRANTIES OF ANY KIND WHETHER EXPRESS OR IMPLIED, WRITTEN OR ORAL, STATUTORY OR OTHERWISE, RELATED TO THE INFORMATION, INCLUDING BUT NOT LIMITED TO ITS CONDITION, QUALITY, PERFORMANCE, MERCHANTABILITY OR FITNESS FOR PURPOSE. Microchip disclaims all liability arising from this information and its use. Use of Microchip devices in life support and/or safety applications is entirely at the buyer's risk, and the buyer agrees to defend, indemnify and hold harmless Microchip from any and all damages, claims, suits, or expenses resulting from such use. No licenses are conveyed, implicitly or otherwise, under any Microchip intellectual property rights.

Trademarks

The Microchip name and logo, the Microchip logo, dsPIC, FlashFlex, flexPWR, JukeBlox, KEELOQ, KEELOQ logo, Klear, LANCheck, MediaLB, MOST, MOST logo, MPLAB, OptoLyzer, PIC, PICSTART, PIC³² logo, RightTouch, SpyNIC, SST, SST Logo, SuperFlash and UNI/O are registered trademarks of Microchip Technology Incorporated in the U.S.A. and other countries.

The Embedded Control Solutions Company and mTouch are registered trademarks of Microchip Technology Incorporated in the U.S.A.

Analog-for-the-Digital Age, BodyCom, chipKIT, chipKIT logo, CodeGuard, dsPICDEM, dsPICDEM.net, ECAN, In-Circuit Serial Programming, ICSP, Inter-Chip Connectivity, KlearNet, KlearNet logo, MiWi, MPASM, MPF, MPLAB Certified logo, MPLIB, MPLINK, MultiTRAK, NetDetach, Omniscient Code Generation, PICDEM, PICDEM.net, PICkit, PICtail, RightTouch logo, REAL ICE, SQI, Serial Quad I/O, Total Endurance, TSHARC, USBCheck, VariSense, ViewSpan, WiperLock, Wireless DNA, and ZENA are trademarks of Microchip Technology Incorporated in the U.S.A. and other countries.

SQTP is a service mark of Microchip Technology Incorporated in the U.S.A.

Silicon Storage Technology is a registered trademark of Microchip Technology Inc. in other countries.

GestIC is a registered trademarks of Microchip Technology Germany II GmbH & Co. KG, a subsidiary of Microchip Technology Inc., in other countries.

All other trademarks mentioned herein are property of their respective companies.

© 2013-2014, Microchip Technology Incorporated, Printed in the U.S.A., All Rights Reserved.

ISBN: 978-1-63276-507-9

QUALITY MANAGEMENT SYSTEM
CERTIFIED BY DNV
== ISO/TS 16949 ==

Microchip received ISO/TS-16949:2009 certification for its worldwide headquarters, design and wafer fabrication facilities in Chandler and Tempe, Arizona; Gresham, Oregon and design centers in California and India. The Company's quality system processes and procedures are for its PIC® MCUs and dsPIC® DSCs, KEELOQ® code hopping devices, Serial EEPROMs, microperipherals, nonvolatile memory and analog products. In addition, Microchip's quality system for the design and manufacture of development systems is ISO 9001:2000 certified.



MICROCHIP

Worldwide Sales and Service

AMERICAS

Corporate Office
2355 West Chandler Blvd.
Chandler, AZ 85224-6199
Tel: 480-792-7200
Fax: 480-792-7277
Technical Support:
<http://www.microchip.com/support>
Web Address:
www.microchip.com

Atlanta
Duluth, GA
Tel: 678-957-9614
Fax: 678-957-1455

Austin, TX
Tel: 512-257-3370

Boston
Westborough, MA
Tel: 774-760-0087
Fax: 774-760-0088

Chicago
Itasca, IL
Tel: 630-285-0071
Fax: 630-285-0075

Cleveland
Independence, OH
Tel: 216-447-0464
Fax: 216-447-0643

Dallas
Addison, TX
Tel: 972-818-7423
Fax: 972-818-2924

Detroit
Novi, MI
Tel: 248-848-4000

Houston, TX
Tel: 281-894-5983

Indianapolis
Noblesville, IN
Tel: 317-773-8323
Fax: 317-773-5453

Los Angeles
Mission Viejo, CA
Tel: 949-462-9523
Fax: 949-462-9608

New York, NY
Tel: 631-435-6000

San Jose, CA
Tel: 408-735-9110

Canada - Toronto
Tel: 905-673-0699
Fax: 905-673-6509

ASIA/PACIFIC

Asia Pacific Office
Suites 3707-14, 37th Floor
Tower 6, The Gateway
Harbour City, Kowloon
Hong Kong
Tel: 852-2943-5100
Fax: 852-2401-3431

Australia - Sydney
Tel: 61-2-9868-6733
Fax: 61-2-9868-6755

China - Beijing
Tel: 86-10-8569-7000
Fax: 86-10-8528-2104

China - Chengdu
Tel: 86-28-8665-5511
Fax: 86-28-8665-7889

China - Chongqing
Tel: 86-23-8980-9588
Fax: 86-23-8980-9500

China - Hangzhou
Tel: 86-571-8792-8115
Fax: 86-571-8792-8116

China - Hong Kong SAR
Tel: 852-2943-5100
Fax: 852-2401-3431

China - Nanjing
Tel: 86-25-8473-2460
Fax: 86-25-8473-2470

China - Qingdao
Tel: 86-532-8502-7355
Fax: 86-532-8502-7205

China - Shanghai
Tel: 86-21-5407-5533
Fax: 86-21-5407-5066

China - Shenyang
Tel: 86-24-2334-2829
Fax: 86-24-2334-2393

China - Shenzhen
Tel: 86-755-8864-2200
Fax: 86-755-8203-1760

China - Wuhan
Tel: 86-27-5980-5300
Fax: 86-27-5980-5118

China - Xian
Tel: 86-29-8833-7252
Fax: 86-29-8833-7256

China - Xiamen
Tel: 86-592-2388138
Fax: 86-592-2388130

China - Zhuhai
Tel: 86-756-3210040
Fax: 86-756-3210049

ASIA/PACIFIC

India - Bangalore
Tel: 91-80-3090-4444
Fax: 91-80-3090-4123

India - New Delhi
Tel: 91-11-4160-8631
Fax: 91-11-4160-8632

India - Pune
Tel: 91-20-3019-1500

Japan - Osaka
Tel: 81-6-6152-7160
Fax: 81-6-6152-9310

Japan - Tokyo
Tel: 81-3-6880-3770
Fax: 81-3-6880-3771

Korea - Daegu
Tel: 82-53-744-4301
Fax: 82-53-744-4302

Korea - Seoul
Tel: 82-2-554-7200
Fax: 82-2-558-5932 or
82-2-558-5934

Malaysia - Kuala Lumpur
Tel: 60-3-6201-9857
Fax: 60-3-6201-9859

Malaysia - Penang
Tel: 60-4-227-8870
Fax: 60-4-227-4068

Philippines - Manila
Tel: 63-2-634-9065
Fax: 63-2-634-9069

Singapore
Tel: 65-6334-8870
Fax: 65-6334-8850

Taiwan - Hsin Chu
Tel: 886-3-5778-366
Fax: 886-3-5770-955

Taiwan - Kaohsiung
Tel: 886-7-213-7830

Taiwan - Taipei
Tel: 886-2-2508-8600
Fax: 886-2-2508-0102

Thailand - Bangkok
Tel: 66-2-694-1351
Fax: 66-2-694-1350

EUROPE

Austria - Wels
Tel: 43-7242-2244-39
Fax: 43-7242-2244-393

Denmark - Copenhagen
Tel: 45-4450-2828
Fax: 45-4485-2829

France - Paris
Tel: 33-1-69-53-63-20
Fax: 33-1-69-30-90-79

Germany - Dusseldorf
Tel: 49-2129-3766400

Germany - Munich
Tel: 49-89-627-144-0
Fax: 49-89-627-144-44

Germany - Pforzheim
Tel: 49-7231-424750

Italy - Milan
Tel: 39-0331-742611
Fax: 39-0331-466781

Italy - Venice
Tel: 39-049-7625286

Netherlands - Drunen
Tel: 31-416-690399
Fax: 31-416-690340

Poland - Warsaw
Tel: 48-22-3325737

Spain - Madrid
Tel: 34-91-708-08-90
Fax: 34-91-708-08-91

Sweden - Stockholm
Tel: 46-8-5090-4654

UK - Wokingham
Tel: 44-118-921-5800
Fax: 44-118-921-5820

03/25/14

Looking for pricing, stock, or lifecycle information?

Click below to explore more details on WIN SOURCE:

- ⊖ [View DSPIC33EP128GM306-I/PT on WIN SOURCE](#)
- ⊖ [Microchip Technology](#) Information

Optimize Your Supply Chain with WIN SOURCE Solutions

- ✓ Global Sourcing Solution
- ✓ Obsolete Management
- ✓ Cost Control Management
- ✓ Shortage Management
- ✓ Alternative Solution
- ✓ Excess Inventory Management