



**THE DATASHEET OF
KA79M08RTF**



KA79MXX/LM79M05

3-Terminal 0.5A Negative Voltage Regulator

Features

- No external components required
- Output current in excess of 0.5A
- Internal thermal overload
- Internal short circuit current limiting
- Output transistor safe area compensation
- Output voltages of -5V,-6V,-8V,-12V,-15V,-18V,-24V

Description

The KA79MXX series and LM79M05 are of 3-Terminal medium current negative voltage regulators are monolithic integrated circuits designed as fixed voltage regulators. These regulators employ internal current limiting, thermal shutdown and safe area compensation making them essentially indestructible.

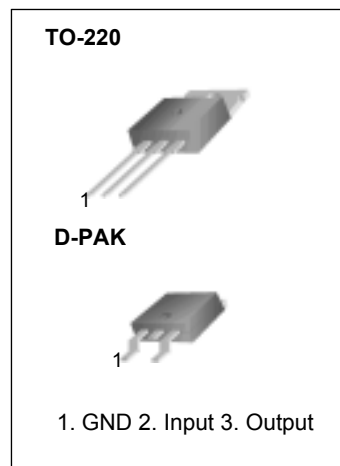

Schematic Diagram

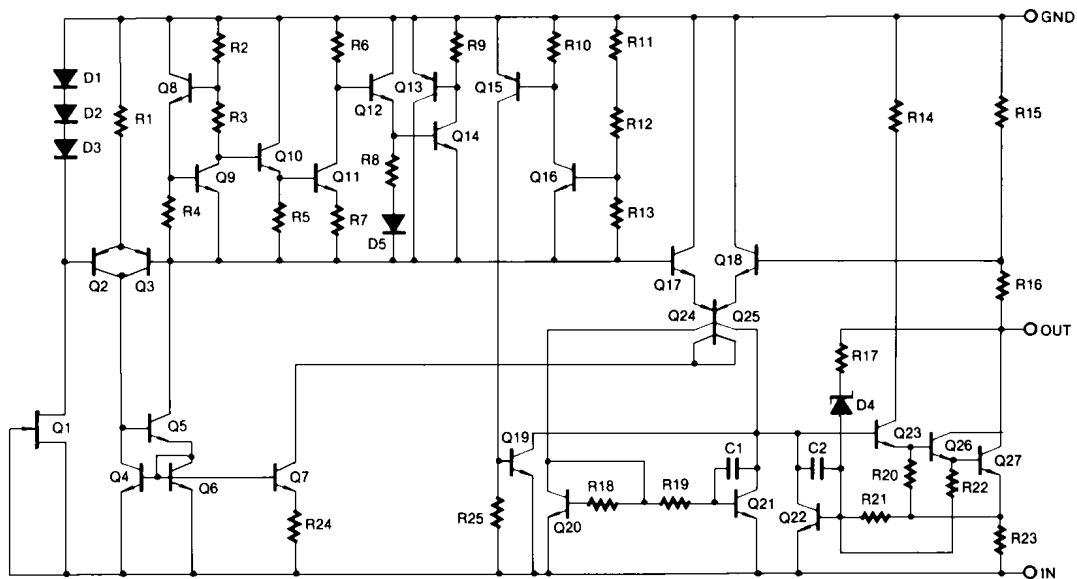

Absolute Maximum Ratings

Parameter	Symbol	Value	Unit
Input Voltage(for VO = -5V to -18V) (for VO = -24V)	VI	-35	V
	VI	-40	V
Thermal Resistance Junction-Cases	RθJC	5	°C /W
Thermal Resistance Junction-Air	RθJA	65	°C /W
Operating Temperature Range	TOPR	0 ~ +125	°C
Storage Temperature Range	TSTG	-65 ~ +125	°C

Electrical Characteristics (KA79M05/KA79M05R/LM79M05)

(Refer to test circuit, $0\text{ }^{\circ}\text{C} \leq T_J \leq +125\text{ }^{\circ}\text{C}$, IO =350mA, VI =-10V, unless otherwise specified, CI =0.33 μ F, CO=0.1 μ F)

Parameter	Symbol	Conditions	Min.	Typ.	Max.	Unit	
Output Voltage	VO	TJ= +25 °C	-4.8	-5	-5.2	V	
		IO = 5mA to 350mA VI = -7V to -25V	-4.75	-5	-5.25		
Line Regulation (Note1)	Δ VO	TJ =+25°C	VI= -7V to -25V	-	7.0	50	mV
			VI= -8V to -25V	-	2.0	30	
Load Regulation (Note1)	Δ VO	IO = 5mA to 500mA TJ = +25 °C	-	30	100	mV	
Quiescent Current	IQ	TJ= +25 °C-		3.0	6.0	mA	
Quiescent Current Change	Δ IQ	IO = 5mA to 350mA	-	-	0.4	mA	
		IO = 200mA VI = -8V to -25V	--0		.4		
Output Voltage Drift	Δ Vo/ Δ TIO	= 5mA	-	-0.2	-	mV/ °C	
Output Noise Voltage	VN	f = 10Hz, 100KHz TA = +25 °C	-4	0- ∞ V			
Ripple Rejection	RR	f = 120Hz VJ= -8Vto -18V	54	60	-	dB	
Dropout Voltage	VD	TJ =+25 °C, IO = 500mA	-	1.1	-	V	
Short Circuit Current	ISC	TJ= +25 °C, VI = -35V	-	140	-	mA	
Peak Current	IPK	TJ= +25 °C	-	650	-	mA	

Note:

1. Load and line regulation are specified at constant junction temperature. Change in VO due to heating effects must be taken into account separately. Pulse testing with low duty is used.

Electrical Characteristics (KA79M06)

(Refer to test circuit, $0\text{ }^{\circ}\text{C} \leq T_J \leq +125\text{ }^{\circ}\text{C}$, $I_O = 350\text{mA}$, $V_I = -11\text{V}$, unless otherwise specified)

Parameter	Symbol	Conditions	Min.	Typ.	Max.	Unit	
Output Voltage	VO	TJ= +25 °C	- 5.75	- 6.0	- 6.25	V	
		IO = 5mA to 350mA VI = -8.0V to -25V	- 5.7	- 6.0	- 6.3		
Line Regulation (Note1)	ΔV_O	TJ = +25°C	VI = -8V to -25V	-	7.0	60	mV
			VI = -9V to -19V	-	2.0	40	
Load Regulation (Note1)	ΔV_O	TJ = +25 °C IO = 5.0mA to 500mA	-	30	120	mV	
Quiescent Current	IQ	TJ = +25 °C-		3	6	mA	
Quiescent Current Change	ΔI_Q	IO = 5mA to 350mA	-	-	0.4	mA	
		VI = -8V to -25V	-	-	0.4		
Output Voltage Drift	$\Delta V_O / \Delta T$	IO = 5mA	-	0.4	-	mV/ °C	
Output Noise Voltage	VN	f = 10Hz to 100KHz, TA = +25 °C-5		0-∞V			
Ripple Rejection	RR	f = 120Hz, VI = -9V to -19V	54	60	-	dB	
Dropout Voltage	VD	IO = 500mA, TJ = +25 °C-		1.1	-	V	
Short Circuit Current	ISC	VI = -35V, TJ = +25 °C	-	140	-	mA	
Peak Current	IPK	TJ = +25 °C	-	650	-	mA	

Note:

1. Load and line regulation are specified at constant junction temperature. Change in VO due to heating effects must be taken into account separately. Pulse testing with low duty is used.

Electrical Characteristics (KA79M08/KA79M08R)

(Refer to test circuit, $0\text{ }^{\circ}\text{C} \leq T_J \leq +125\text{ }^{\circ}\text{C}$, $I_O = 350\text{mA}$, $V_I = -14\text{V}$, unless otherwise specified)

Parameter	Symbol	Conditions	Min.	Typ.	Max.	Unit	
Output Voltage	VO	TJ= +25 °C	- 7.7	- 8.0	- 8.3	V	
		IO = 5mA to 350mA VI = -10.5V to -25V	- 7.6	- 8.0	- 8.4		
Line Regulation (Note1)	ΔVO	TJ = +25°C	VI = -10.5V to -25V	-	7.0	80	mV
			VI = -11V to -21V	-	2.0	50	
Load Regulation (Note1)	ΔVO	TJ = +25 °C IO = 5.0mA to 500mA	-	30	160	mV	
Quiescent Current	IQ	TJ = +25 °C-		3	6	mA	
Quiescent Current Change	ΔIQ	IO = 5mA to 350mA	-	-	0.4	mA	
		VI = -8V to -25V	-	-	0.4		
Output Voltage Drift	ΔVO/ΔT	IO = 5mA	-	-0.6	-	mV/ °C	
Output Noise Voltage	VN	f = 10Hz to 100KHz, TA = +25 °C-6		0-∞	V		
Ripple Rejection	RR	f = 120Hz, VI = -9V to -19V	54	59	-	dB	
Dropout Voltage	VD	IO = 500mA, TJ = +25 °C-		1.1	-	V	
Short Circuit Current	ISC	VI = -35V, TJ = +25 °C	-	140	-	mA	
Peak Current	IPK	TJ = +25 °C	-	650	-	mA	

Note:

1. Load and line regulation are specified at constant junction temperature. Change in VO due to heating effects must be taken into account separately. Pulse testing with low duty is used.

Electrical Characteristics (KA79M12)

(Refer to test circuit, $0\text{ }^{\circ}\text{C} \leq T_J \leq +125\text{ }^{\circ}\text{C}$, $I_O = 350\text{mA}$, $V_I = -19\text{V}$, unless otherwise specified)

Parameter	Symbol	Conditions	Min.	Typ.	Max.	Unit	
Output Voltage	VO	TJ= +25 °C	-11.5	-12	-12.5	V	
		IO = 5mA to 350mA VI = -14.5V to -30V	-11.4	-12	-12.6		
Line Regulation (Note1)	ΔV_O	TJ = +25 °C	VI = -14.5V to -30V	-	8.0	80	mV
			VI = -15V to -25V	-	3.0	50	
Load Regulation (Note1)	ΔV_O	TJ = +25 °C	IO = 5.0mA to 500mA	-	30	240	mV
Quiescent Current	IQ	TJ = +25 °C-		3	6	mA	
Quiescent Current Change	ΔI_Q	IO = 5mA to 350mA		-	-	0.4	mA
		VI = -14.5V to -30V		-	-	0.4	
Output Voltage Drift	$\Delta V_O / \Delta T$	IO = 5mA		-	-0.8	-	mV/ °C
Output Noise Voltage	VN	f = 10Hz to 100KHz, TA = +25 °C-7			5-∞V		
Ripple Rejection	RR	f = 120Hz, VI = -15V to -25V		54	60	-	dB
Dropout Voltage	VD	IO = 500mA, TJ = +25 °C-			1.1	-	V
Short Circuit Current	ISC	VI = -35V, TJ = +25 °C		-	140	-	mA
Peak Current	IPK	TJ = +25 °C		-	650	-	mA

Note:

1. Load and line regulation are specified at constant junction temperature. Change in VO due to heating effects must be taken into account separately. Pulse testing with low duty is used.

Electrical Characteristics (KA79M15)

(Refer to test circuit, $0\text{ }^{\circ}\text{C} \leq T_J \leq +125\text{ }^{\circ}\text{C}$, $I_O = 350\text{mA}$, $V_I = -23\text{V}$, unless otherwise specified)

Parameter	Symbol	Conditions	Min.	Typ.	Max.	Unit	
Output Voltage	VO	TJ= +25 °C	- 14.4	- 15	- 15.6	V	
		IO = 5mA to 350mA VI = -17.5V to -30V	-14.25	- 15	-15.75		
Line Regulation (Note1)	ΔVO	TJ = +25°C	VI = -17.5V to -30V	-	9.0	80	mV
			VI = -18V to -28V	-	5.0	50	
Load Regulation (Note1)	ΔVO	TJ= +25 °C IO = 5.0mA to 500mA	-	30	240	mV	
Quiescent Current	IQ	TJ= +25 °C-		3	6	mA	
Quiescent Current Change	ΔIQ	IO = 5mA to 350mA	-	-	0.4	mA	
		VI = -17.5V to -28V	-	-	0.4		
Output Voltage Drift	ΔVO/ΔT	IO = 5mA	-	-1.0	-	mV/ °C	
Output Noise Voltage	VN	f = 10Hz to 100KHz, TA = +25 °C-9		0-∞V			
Ripple Rejection	RR	f = 120Hz, VI = -18.5V to -28.5V	54	59	-	dB	
Dropout Voltage	VD	IO = 500mA, TJ = +25 °C-		1.1	-	V	
Short Circuit Current	ISC	VI = -35V, TJ = +25 °C	-	140	-	mA	
Peak Current	IPK	TJ= +25 °C	-	650	-	mA	

Note:

1. Load and line regulation are specified at constant junction temperature. Change in VO due to heating effects must be taken into account separately. Pulse testing with low duty is used.

Electrical Characteristics (KA79M18)

(Refer to test circuit, $0\text{ }^{\circ}\text{C} \leq T_J \leq +125\text{ }^{\circ}\text{C}$, $I_O = 350\text{mA}$, $V_I = -27\text{V}$, unless otherwise specified)

Parameter	Symbol	Conditions	Min.	Typ.	Max.	Unit	
Output Voltage	VO	TJ= +25 °C	- 17.3	- 18	- 18.7	V	
		IO = 5mA to 350mA VI = -21V to -33V	- 17.1	- 18	- 18.9		
Line Regulation (Note1)	ΔV_O	TJ = +25°C	VI = -21V to -33V	-	9.0	80	mV
			VI = -24V to -30V	-	5.0	80	
Load Regulation (Note1)	ΔV_O	TJ= +25 °C IO = 5.0mA to 500mA	-	30	360	mV	
Quiescent Current	IQ	TJ= +25 °C-		3	6	mA	
Quiescent Current Change	ΔI_Q	IO = 5mA to 350mA	-	-	0.4	mA	
		VI = -21V to -33V	-	-	0.4		
Output Voltage Drift	$\Delta V_O / \Delta T$	IO = 5mA	-	-1.0	-	mV/ °C	
Output Noise Voltage	VN	f = 10Hz to 100KHz, TA = +25 °C-1		10 ^{-α}	V		
Ripple Rejection	RR	f = 120Hz, VI = -22V to -32V	54	59	-	dB	
Dropout Voltage	VD	IO = 500mA, TJ = +25 °C-		1.1	-	V	
Short Circuit Current	ISC	VI = -35V, TJ = +25 °C	-	140	-	mA	
Peak Current	IPK	TJ= +25 °C	-	650	-	mA	

Note;

1. Load and line regulation are specified at constant junction temperature. Change in VO due to heating effects must be taken into account separately. Pulse testing with low duty is used.

Electrical Characteristics (KA79M24)

(Refer to test circuit, $0\text{ }^{\circ}\text{C} \leq T_J \leq +125\text{ }^{\circ}\text{C}$, $I_O = 350\text{mA}$, $V_I = -33\text{V}$, unless otherwise specified)

Parameter	Symbol	Conditions	Min.	Typ.	Max.	Unit	
Output Voltage	VO	TJ= +25 °C	- 23	- 24	- 25	V	
		IO = 5mA to 350mA VI = -27V to -38V	- 22.8	- 24	- 25.2		
Line Regulation (Note1)	ΔVO	TJ = +25°C	VI = -27V to -38V	-	9.0	80	mV
			VI = -30V to -36V	-	5.0	70	
Load Regulation (Note1)	ΔVO	TJ= +25 °C IO = 5.0mA to 500mA	-	30	300	mV	
Quiescent Current	IQ	TJ= +25 °C-		3	6	mA	
Quiescent Current Change	ΔIQ	IO = 5mA to 350mA	-	-	0.4	mA	
		VI = -27V to -38V	-	-	0.4		
Output Voltage Drift	ΔVO/ΔTIO = 5mA		-	-1.0	-	mV/ °C	
Output Noise Voltage	VN	f = 10Hz to 100KHz, TA = +25 °C	-	180	-	μV	
Ripple Rejection	RR	f = 120Hz, VI = -28V to -38V	54	58	-	dB	
Dropout Voltage	VD	IO = 500mA, TJ = +25 °C-		1.1	-	V	
Short Circuit Current	ISC	VI = -35V, TJ = +25 °C	-	140	-	mA	
Peak Current	IPK	TJ= +25 °C	-	650	-	mA	

Note:

1. Load and line regulation are specified at constant junction temperature. Change in VO due to heating effects must be taken into account separately. Pulse testing with low duty is used.

Typical Applications

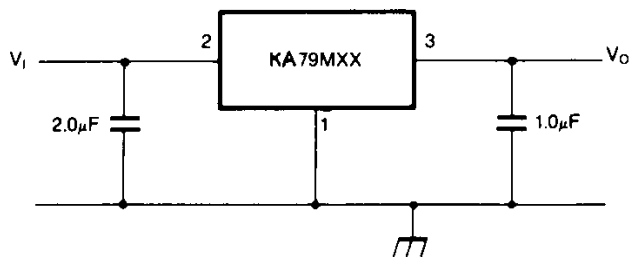

Figure 1. Fixed Output Regulator

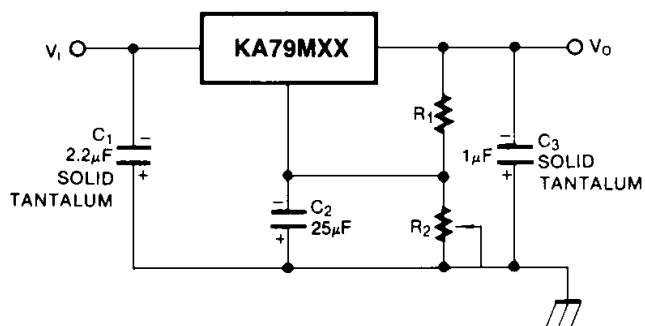

Figure 2. Variable Output

Notes:

1. Required for stability. For value given, capacitor must be solid tantalum. 25 μ F aluminum electrolytic may be substituted.
2. C2 improves transient response and ripple rejection. Do not increase beyond 50 μ F.

Mechanical Dimensions

Package

Dimensions in millimeters

TO-220

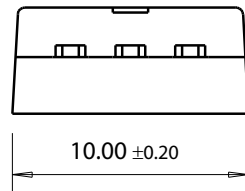
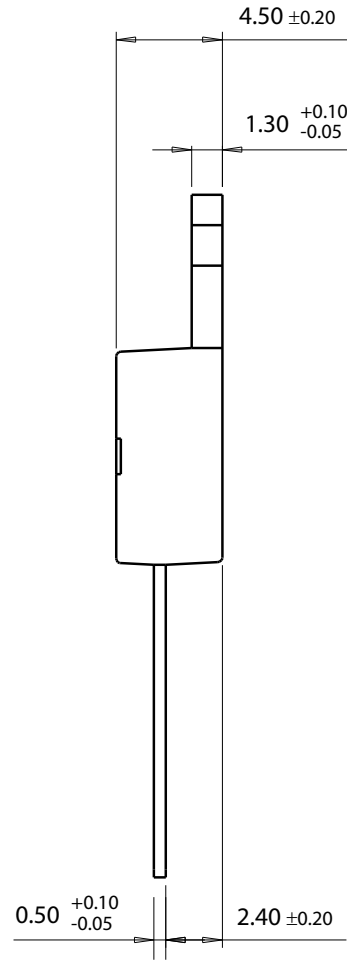
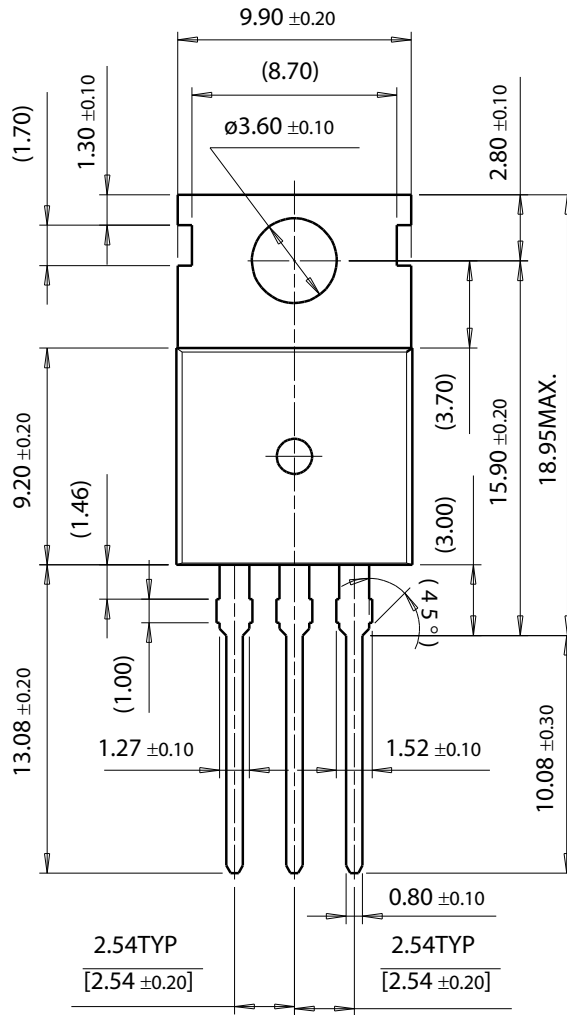

Mechanical Dimensions (Continued)

Package

Dimensions in millimeters

D-PAK

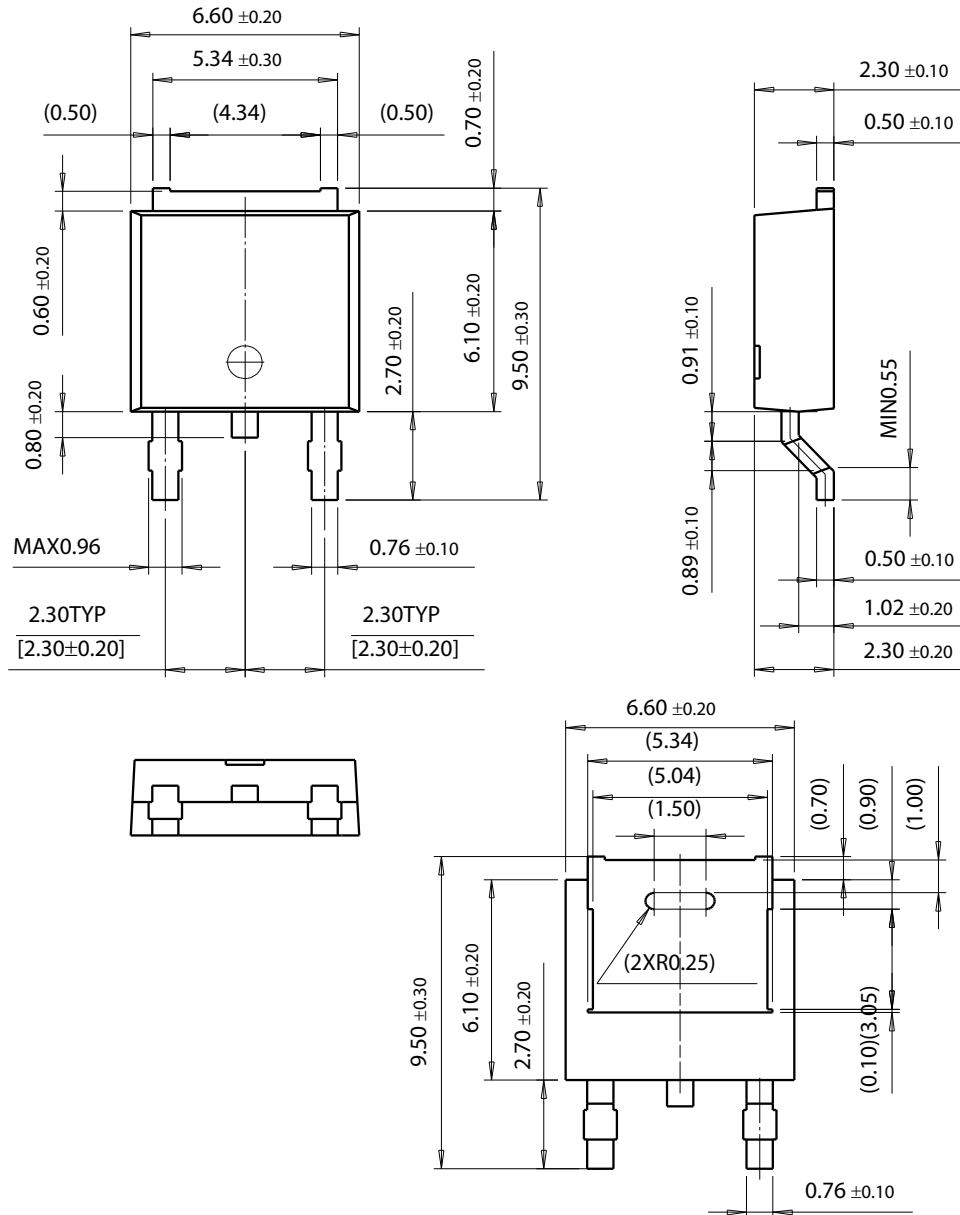

Ordering Information

Product Number	Package	Operating Temperature
KA79M05	TO-220	0 ~ + 125°C
KA79M06		
KA79M08		
KA79M12		
KA79M15		
KA79M18		
KA79M24		
LM79M05		
KA79M05R	D-PAK	
KA79M08R		
KA79M12R		

DISCLAIMER

FAIRCHILD SEMICONDUCTOR RESERVES THE RIGHT TO MAKE CHANGES WITHOUT FURTHER NOTICE TO ANY PRODUCTS HEREIN TO IMPROVE RELIABILITY, FUNCTION OR DESIGN. FAIRCHILD DOES NOT ASSUME ANY LIABILITY ARISING OUT OF THE APPLICATION OR USE OF ANY PRODUCT OR CIRCUIT DESCRIBED HEREIN; NEITHER DOES IT CONVEY ANY LICENSE UNDER ITS PATENT RIGHTS, NOR THE RIGHTS OF OTHERS.

LIFE SUPPORT POLICY

FAIRCHILD'S PRODUCTS ARE NOT AUTHORIZED FOR USE AS CRITICAL COMPONENTS IN LIFE SUPPORT DEVICES OR SYSTEMS WITHOUT THE EXPRESS WRITTEN APPROVAL OF THE PRESIDENT OF FAIRCHILD SEMICONDUCTOR CORPORATION. As used herein:

1. Life support devices or systems are devices or systems which, (a) are intended for surgical implant into the body, or (b) support or sustain life, and (c) whose failure to perform when properly used in accordance with instructions for use provided in the labeling, can be reasonably expected to result in a significant injury of the user.
2. A critical component in any component of a life support device or system whose failure to perform can be reasonably expected to cause the failure of the life support device or system, or to affect its safety or effectiveness.

Looking for pricing, stock, or lifecycle information?

Click below to explore more details on WIN SOURCE:

- ⊖ [View KA79M08RTF on WIN SOURCE](#)
- ⊖ [Fairchild/ON Semiconductor Information](#)

Optimize Your Supply Chain with WIN SOURCE Solutions

- ✓ Global Sourcing Solution
- ✓ Obsolete Management
- ✓ Cost Control Management
- ✓ Shortage Management
- ✓ Alternative Solution
- ✓ Excess Inventory Management