



MIC94050/94051

4-Terminal SymFET™ P-Channel MOSFET



General Description

The MIC94050 and MIC94051 are 4-terminal silicon gate P-channel MOSFETs that provide low on-resistance in a very small package.

Designed for high-side switch applications where space is critical, the MIC94050/1 exhibits an on-resistance of typically 0.125Ω at 4.5V gate-to-source voltage. The MIC94050/1 also operates with only 1.8V gate-to-source voltage.

The MIC94050 is the basic 4-lead P-channel MOSFET. The MIC94051 is a variation that includes an internal gate pull-up resistor that can reduce the system parts count in many applications.

The 4-terminal SOT-143 package permits a substrate connection separate from the source connection. This 4-terminal configuration improves the θ_{JA} (improved heat dissipation) and makes reverse-blocking switch applications practical.

The small size, low threshold, and low $R_{DS(on)}$ make the MIC94050/1 the ideal choice for PCMCIA, USB, back-up battery-power, and distributed power management applications.

Features

- 0.125Ω typical on-resistance at 4.5V gate-to-source voltage
- Operates with 1.8V gate-to-source voltage
- Separate substrate connection allows reverse-blocking

Applications

- Distributed power management
- PCMCIA card power management
- USB ports
- Battery-powered computers, peripherals
- Handheld bar-code scanners
- Portable communications equipment
- Reverse blocking battery management

Ordering Information

Part Number	Temp. Range*	Package	Pb-FREE
MIC94050BM4	-40°C to +150°C	SOT-143	NO
MIC94051BM4	-40°C to +150°C	SOT-143	NO
MIC94050YM4	-40°C to +150°C	SOT-143	YES
MIC94051YM4	-40°C to +150°C	SOT-143	YES

* Operating Junction Temperature

Pin Configuration

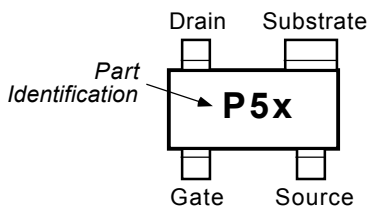

Part Number	Identification
MIC94050BM4	P50
MIC94051BM4	P51
MIC94050YM4	P50
MIC94051YM4	P51

SOT-143 Package (M4)

Typical PCB Layout

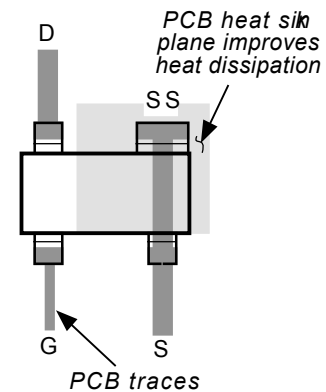

Schematic Symbol

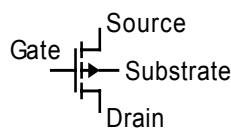

Schematic Symbol

Functional Diagrams

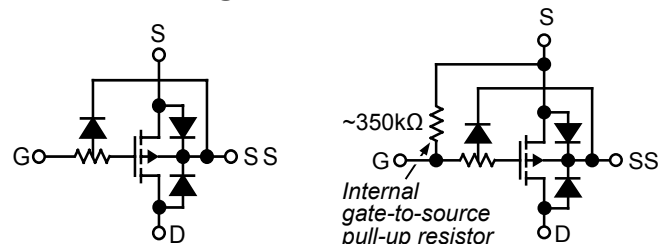

MIC94050

MIC94051

SymFET is a trademark of Micrel, Inc.

Micrel, Inc. • 1849 Fortune Drive • San Jose, CA 95131 • USA • tel + 1 (408) 944-0800 • fax + 1 (408) 944-0970 • <http://www.micrel.com>

Absolute Maximum Ratings

Drain-to-Source Voltage	-6V
Gate-to-Source Voltage	-6V
Continuous Drain Current	
$T_A = 25^\circ\text{C}$ ($V_{GS} = 4.5\text{V}$)	1.8A
$T_A = 100^\circ\text{C}$ ($V_{GS} = 4.5\text{V}$)	1.2A
Total Power Dissipation	
$T_A = 25^\circ\text{C}$	568mW
$T_A = 100^\circ\text{C}$	227mW
Operating Junction Temperature	-40°C to +150°C
Storage Temperature	-55°C to +150°C
ESD Rating, Note 2	

Operating Ratings

Thermal Resistance	
θ_{JA}	220°C/W
θ_{JC}	130°C/W

Electrical Characteristics (Note 1)

Symbol	Parameter	Condition (Note 1)	Min	Typ	Max	Units
V_{GS}	Gate Threshold Voltage	$V_{DS} = V_{GS}$, $I_D = -250\mu\text{A}$	0.5		1.2	V
I_{GSS}	Gate-Body Leakage	$V_{DS} = 0\text{V}$, $V_{GS} = -4.5\text{V}$, Note 2, Note 3			1	μA
R_{GS}	Gate-Source Resistance	$V_{DS} = 0\text{V}$, $V_{GS} = -4.5\text{V}$, Note 2, Note 4	200	350	500	k Ω
C_{ISS}	Input Capacitance	$V_{GS} = 0\text{V}$, $V_{DS} = -5.5\text{V}$		600		pF
I_{DSS}	Zero Gate Voltage Drain Current	$V_{DS} = -5.5\text{V}$, $V_{GS} = 0\text{V}$			1	μA
		$V_{DS} = -5.5\text{V}$, $V_{GS} = 0\text{V}$, $T_J = 85^\circ\text{C}$			5	μA
$R_{DS(ON)}$	Drain-Source On-Resistance	$V_{GS} = -4.5\text{V}$, $I_D = -100\text{mA}$		0.125	0.160	Ω
		$V_{GS} = -3.6\text{V}$, $I_D = -100\text{mA}$		0.135	0.180	Ω
		$V_{GS} = -2.5\text{V}$, $I_D = -100\text{mA}$		0.165	0.200	Ω
		$V_{GS} = -1.8\text{V}$, $I_D = -100\text{mA}$		0.225	0.320	Ω
g_{FS}	Forward Transconductance	$V_{DS} = -5.5\text{V}$, $I_D = -200\text{mA}$, Note 5		3		S

Note 1. $T_A = 25^\circ\text{C}$ unless noted. Substrate connected to source for all conditions.

Note 2. ESD gate \square precautions required

Note 3. MIC94050 only.

Note 4. MIC94051 only.

Note 5. Pulse Test: Pulse Width $\leq 80\mu\text{s}$, Duty Cycle $\leq 0.5\%$.

Typical Characteristics

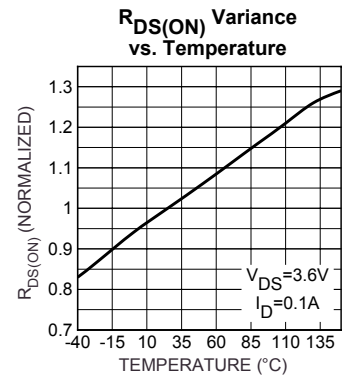
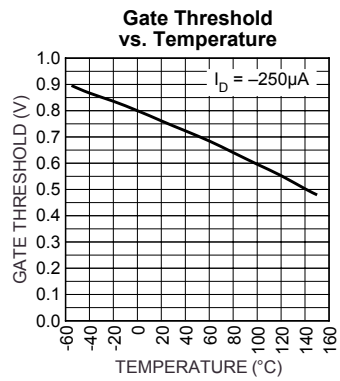
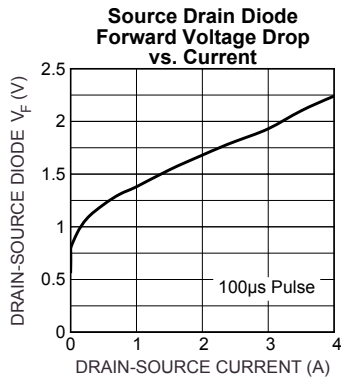
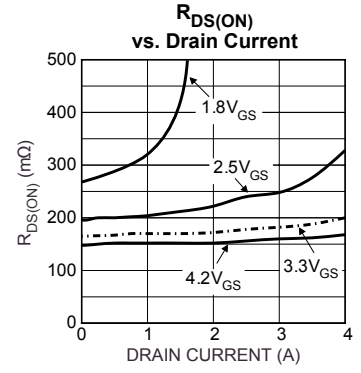
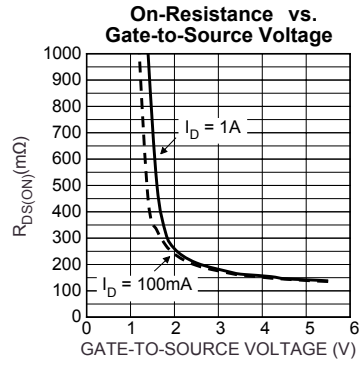
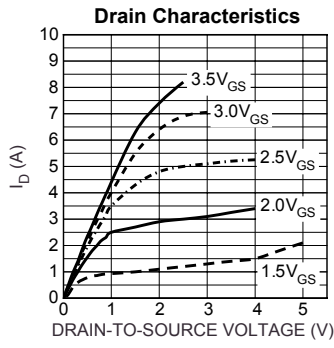

Typical Applications

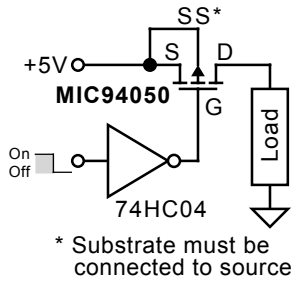

Figure 1. Load Switch Application

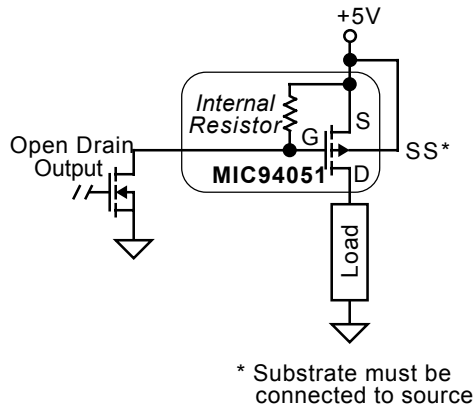

Figure 2. Load Switch Application (with internal gate-source pull-up)

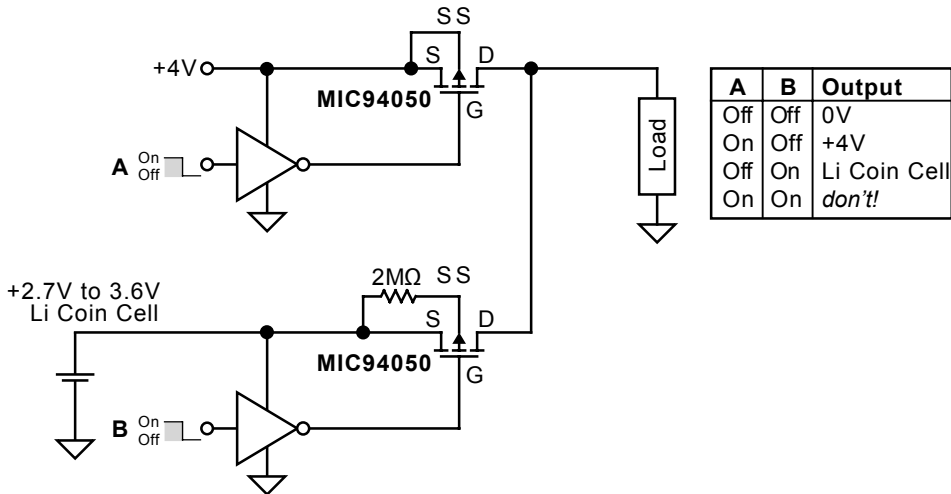
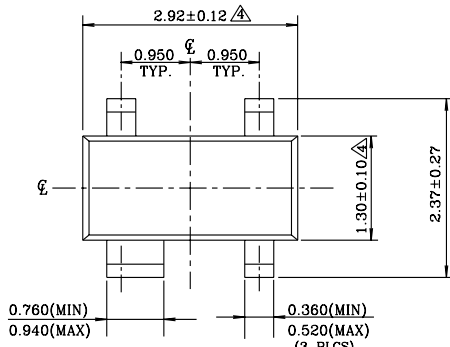
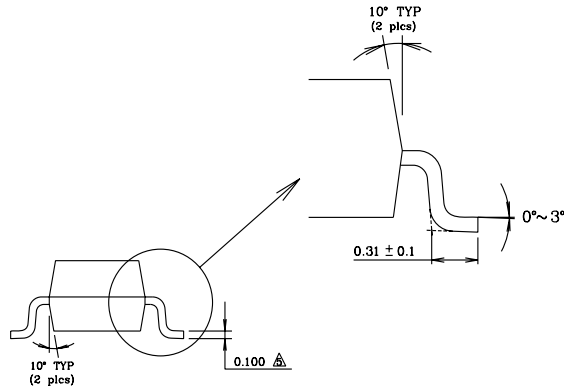

Figure 3. Reverse-Blocking Battery Back-Up Application

Package Information



TOP VIEW



END VIEW

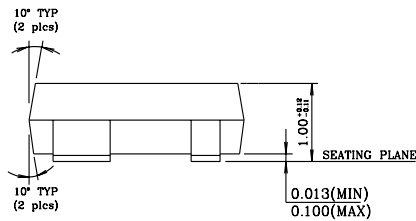

SIDE VIEW

NOTE:

1. Dimensions and tolerances are as per ANSI Y14.5M, 1982.
 2. Package surface to be mirror finish.
 3. Die is facing up for mold & trim/form.
- △ Dimension are exclusive of mold flash and gate burr.
 - △ Dimension are exclusive of solder plating.

SOT-143 (M4)

MICREL, INC. 2180 FORTUNE DRIVE SAN JOSE, CA 95131 USA

TEL + 1 (408) 944-0800 FAX + 1 (408) 474-1000 WEB <http://www.micrel.com>

The information furnished by Micrel in this data sheet is believed to be accurate and reliable. However, no responsibility is assumed by Micrel for its use. Micrel reserves the right to change circuitry and specifications at any time without notification to the customer.

Micrel Products are not □

reasonably be expected to result in personal injury. Life support devices or systems are devices or systems that (a) are intended for surgical implant into the body or (b) support or sustain life, and whose failure to perform can be reasonably expected to result in a significant injury to the user. A Purchaser's use or sale of Micrel Products for use in life support appliances, devices or systems is a Purchaser's own risk and Purchaser agrees to fully indemnify Micrel for any damages resulting from such use or sale.

Looking for pricing, stock, or lifecycle information?

Click below to explore more details on WIN SOURCE:

-  [View MIC94051BM4 TR on WIN SOURCE](#)
-  [Microchip Technology](#) Information

Optimize Your Supply Chain with WIN SOURCE Solutions

-  Global Sourcing Solution
-  Obsolete Management
-  Cost Control Management
-  Shortage Management
-  Alternative Solution
-  Excess Inventory Management