



# THE DATASHEET OF TLE6363G



## Data Sheet

### Overview

### Features

- Step up converter (Boost Voltage)
- Boost Over- and Under-Voltage-Lockout
- Step down converter (Logic Voltage)
- 2% output voltage tolerance
- Logic Over- and Under-Voltage-Lockout
- Overtemperature Shutdown
- Power ON/OFF reset generator
- Digital window watchdog
- System Enable Output
- Ambient operation temperature range – 40 °C to 125 °C
- Wide Supply voltage operation range
- Very low current consumption
- Very small P-DSO-14-2 SMD package

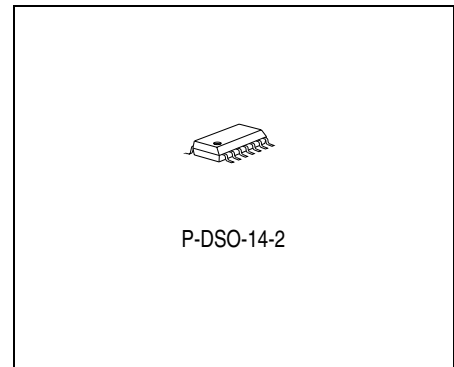

Type	Ordering Code	Package
TLE 6363 G	Q67006-A9601	P-DSO-14-2

### Functional Description

#### General

The **TLE 6363 G** is a multifunctional power supply circuit especially designed for automotive applications.

It delivers a programmable step up voltage (Boost) and a precise 5 V fully short circuit protected output voltage (Buck).

The **TLE 6363 G** contains a power on reset feature to start up the system, an integrated digital window watchdog to monitor the connected microcontroller and a system enable output to indicate the microcontroller window watchdog faults.

The device is based on Infineon's power technology SPT® which allows bipolar and CMOS control circuitry to be integrated with DMOS power devices on the same monolithic circuitry.

The very small **P-DSO-14-2** SMD packages meet the application requirements.

Furthermore, the build-in features like under- and overvoltage lockout for boost- and buck-voltage and the overtemperature shutdown feature increase the reliability of the **TLE 6363 G** supply system.

### Pin Definitions and Functions

Pin No. SO-14	Symbol	Function
1	R	<b>Reference Input</b> ; an external resistor from this pin to GND determines the reference current and the oscillator frequency
2	RO	<b>Reset Output</b> ; open drain output from reset comparator with an internal pull up resistor
3	WDI	<b>Watchdog Input</b> ; input for the watchdog control signal from the controller
4	GND	<b>Ground</b> ; analog signal ground
5	SEN	<b>System Enable Output</b> ; open drain output from Watchdog fail-circuit with an internal pull up resistor
6	BUC	<b>Buck-Converter Compensation Input</b> ; output of internal error amplifier; for loop-compensation connect an external R-C-series combination to GND
7	$V_{CC}$	<b>Supply Voltage Output</b> ; buck converter output; external blocking capacitor necessary
8	BUO	<b>Buck Converter Output</b> ; source of the integrated power-DMOS
9	$V_{BOOST}$	<b>Boost Converter Input</b> ; input supply voltage of the IC; coming from the boost converter output voltage; buck converter input voltage
10	BDS	<b>Buck Driver Supply Input</b> ; voltage to drive the buck converter powerstage
11	OVL	<b>Boost Status Output</b> ; open drain output from boost PWM comparator
12	BOFB	<b>Boost Converter Feedback Input</b> ; connect boost voltage divider to this pin; internal reference is the boost feedback threshold $V_{BOFBTH}$
13	BOGND	<b>Boost-Ground</b> ; power signal ground; source of boost converter power-DMOS
14	BOI	<b>Boost Converter Input</b> ; drain of the integrated buck converter power-DMOS

### Pin Configuration

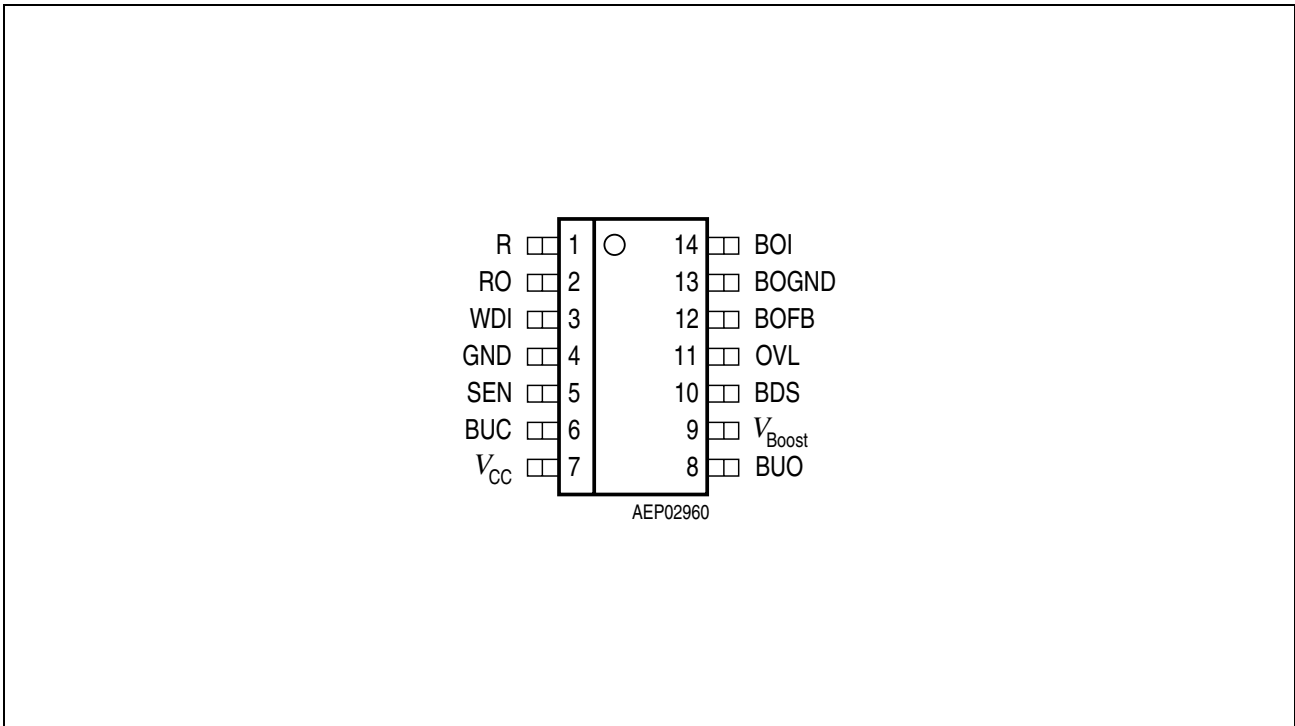

**Figure 1** Pin Configuration (top view)

**Block Diagram**

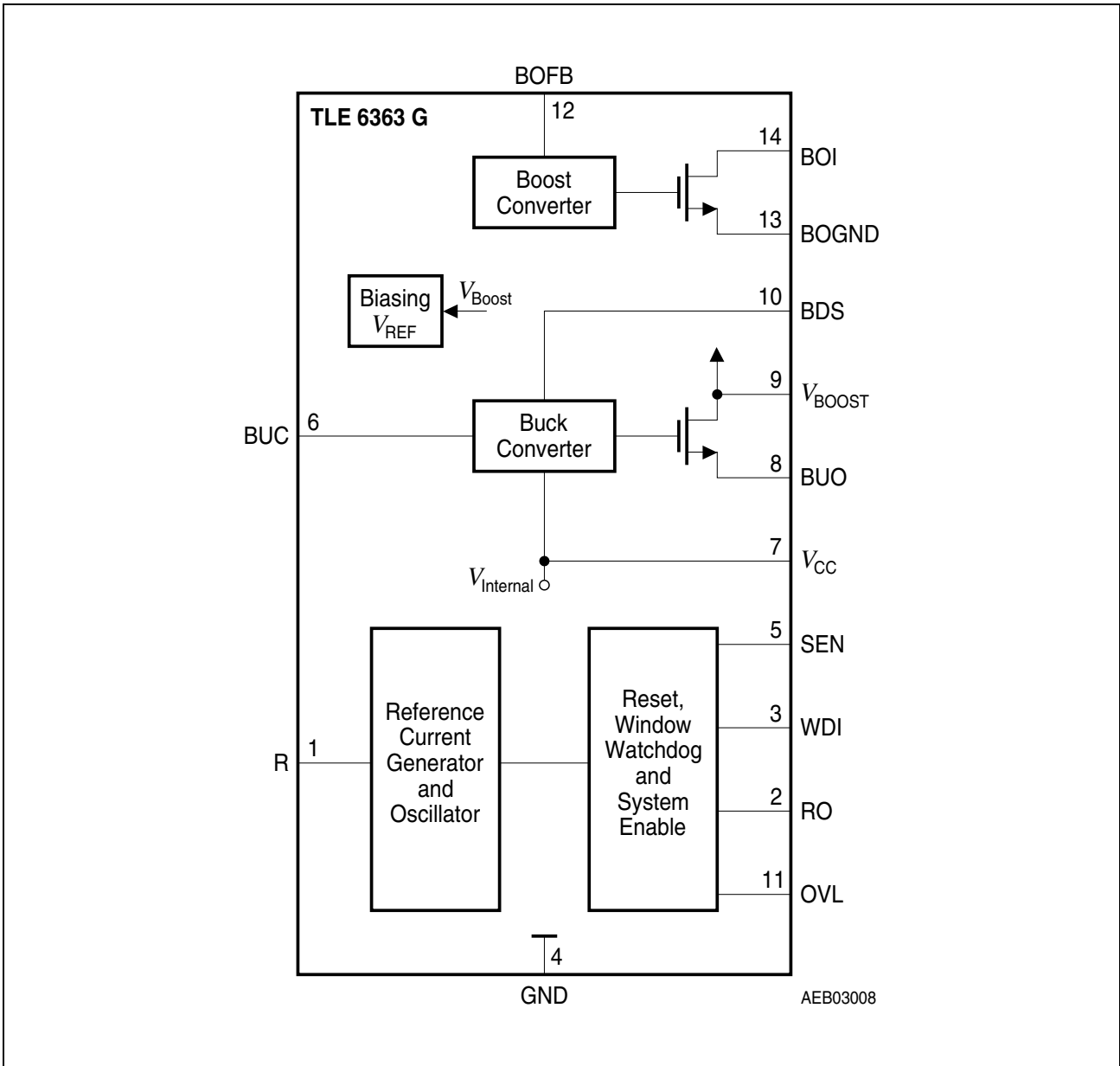

**Figure 2 Block Diagram**

**Absolute Maximum Ratings**

Parameter	Symbol	Limit Values		Unit	Remarks
		min.	max.		

**Voltages**

Boost input voltage	$V_{BOI}$	- 0.3	46	V	-
Boost output voltage	$V_{BOOST}$	- 0.3	46	V	-
Boost feedback voltage	$V_{BOFB}$	- 0.3	46	V	-
Buck output voltage	$V_{BUO}$	- 1	46	V	-
Buck driver supply voltage	$V_{BDS}$	- 0.3	48	V	-
Buck compensation input voltage	$V_{BUC}$	- 0.3	6.8	V	-
Logic supply voltage	$V_{CC}$	- 0.3	6.8	V	-
Reset output voltage	$V_{RO}$	- 0.3	6.8	V	-
System Enable output voltage	$V_{SEN}$	- 0.3	6.8	V	-
Current reference voltage	$V_R$	- 0.3	6.8	V	-
Watchdog input voltage	$V_{WDI}$	- 0.3	6.8	V	-
OVL output voltage	$V_{OVL}$	- 0.3	6.8	V	-

**ESD-Protection (Human Body Model;  $R = 1.5 \text{ k}\Omega$ ;  $C = 100 \text{ pF}$ )**

All pins to GND	$V_{HBM}$	- 2	2	kV	-
-----------------	-----------	-----	---	----	---

**Temperatures**

Junction temperature	$T_j$	- 40	150	°C	-
Storage temperature	$T_{stg}$	- 50	150	°C	-

*Note: Stresses above those listed here may cause permanent damage to the device. Exposure to absolute maximum rating conditions for extended periods may affect device reliability.*

**Operating Range**

Parameter	Symbol	Limit Values		Unit	Remarks
		min.	max.		
Boost input voltage	$V_{BOI}$	- 0.3	40	V	-
Boost input voltage; (normal operation)	$V_{BOOST}$	5	35	V	$V_{BOOST}$ increasing
Boost input voltage; (normal operation)	$V_{BOOST}$	4.5	36	V	$V_{BOOST}$ decreasing
Boost input voltage	$V_{BOOST}$	- 0.3	4.5	V	Boost- and Buck-Converter OFF
Boost feedback voltage	$V_{BOFB}$	0	3.0	V	-
Buck output voltage	$V_{BUO}$	- 0.6	40	V	-
Buck driver supply voltage	$V_{BDS}$	- 0.3	48	V	-
Buck compensation input voltage	$V_{BUC}$	0	3.0	V	-
Logic supply voltage	$V_{CC}$	4.00	6.25	V	-
Reset output voltage	$V_{RO}$	- 0.3	$V_{CC} + 0.3$	V	-
System Enable output voltage	$V_{SEN}$	- 0.3	$V_{CC} + 0.3$	V	-
Watchdog input voltage	$V_{WDI}$	0	$V_{CC} + 0.3$	V	-
Current reference voltage	$V_R$	0	3.0	V	-
Junction temperature	$T_j$	- 40	150	°C	-

**Thermal Resistance**

Junction ambient	$R_{thj-a}$	-	120	K/W	-
------------------	-------------	---	-----	-----	---

*Note: In the operating range, the functions given in the circuit description are fulfilled.*

### Electrical Characteristics

$8\text{ V} < V_{\text{Boost}} < 35\text{ V}$ ;  $4.75\text{ V} < V_{\text{CC}} < 5.25\text{ V}$ ;  $-40\text{ }^{\circ}\text{C} < T_j < 150\text{ }^{\circ}\text{C}$ ;  $R_{\text{R}} = 47\text{ k}\Omega$ ; all voltages with respect to ground; positive current defined flowing into pin; unless otherwise specified.

Parameter	Symbol	Limit Values			Unit	Test Conditions
		min.	typ.	max.		

### Current Consumption

Current consumption; see application circuit	$I_{\text{Boost}}$	–	1.5	4	mA	$I_{\text{CC}} = 0\text{ mA}$ ; $I_{\text{BoLoad}} = 0\text{ mA}$
Current consumption; see application circuit	$I_{\text{Boost}}$	–	5	10	mA	$I_{\text{CC}} = 200\text{ mA}$ ; $I_{\text{BoLoad}} = 50\text{ mA}$

### Under- and Over-Voltage Lockout at $V_{\text{Boost}}$

UV ON voltage; boost and buck conv. ON	$V_{\text{BOUVON}}$	4.0	4.5	5.0	V	$V_{\text{BOOST}}$ increasing;
UV OFF voltage; boost and buck conv. OFF	$V_{\text{BOUVOFF}}$	3.5	4.0	4.5	V	$V_{\text{BOOST}}$ decreasing
UV Hysteresis voltage	$V_{\text{BOUVHY}}$	0.2	0.5	1.0	V	HY = ON - OFF
OV OFF voltage; boost conv. OFF	$V_{\text{BOOVFF}}$	34	37	40	V	$V_{\text{BOOST}}$ increasing
OV ON voltage; boost conv. ON	$V_{\text{BOOVON}}$	30	33	36	V	$V_{\text{BOOST}}$ decreasing
OV Hysteresis voltage	$V_{\text{BOUVHY}}$	1.5	4	10	V	HY = OFF - ON

### Over-Voltage Lockout at $V_{\text{CC}}$

OV OFF voltage; buck conv. OFF	$V_{\text{BUOVOFF}}$	5.5	6.0	6.5	V	$V_{\text{CC}}$ increasing
OV ON voltage; buck conv. ON	$V_{\text{BUOVON}}$	5.25	5.75	6.25	V	$V_{\text{CC}}$ decreasing
OV Hysteresis voltage	$V_{\text{BUOVHY}}$	0.10	0.25	0.50	V	HY = OFF - ON

**Electrical Characteristics (cont'd)**

8 V <  $V_{\text{Boost}}$  < 35 V; 4.75 V <  $V_{\text{CC}}$  < 5.25 V;  $-40\text{ }^{\circ}\text{C} < T_j < 150\text{ }^{\circ}\text{C}$ ;  $R_{\text{R}} = 47\text{ k}\Omega$ ; all voltages with respect to ground; positive current defined flowing into pin; unless otherwise specified.

Parameter	Symbol	Limit Values			Unit	Test Conditions
		min.	typ.	max.		

**Boost-Converter; BOI, BOFB and  $V_{\text{BOOST}}$** 

Boost voltage; see application circuit	$V_{\text{BOOST}}$	24.0	27.5	31.0	V	$5\text{ mA} < I_{\text{Boost}} < 100\text{ mA}$ ; $T_j = 25\text{ }^{\circ}\text{C}$ $8\text{ V} < V_{\text{Batt}} < 16\text{ V}$
Boost Voltage; see application circuit	$V_{\text{BOOST}}$	23	–	32	V	$5\text{ mA} < I_{\text{Boost}} < 100\text{ mA}$ ; $8\text{ V} < V_{\text{Batt}} < 16\text{ V}$
Efficiency; see. appl. circuit	$\eta$	–	80	–	%	$I_{\text{Boost}} = 100\text{ mA}$
Power-Stage ON resistance	$R_{\text{BOON}}$	–	0.6	0.75	$\Omega$	$T_j = 25\text{ }^{\circ}\text{C}$ ; $I_{\text{BOI}} = 1\text{ A}$
Power-Stage ON resistance	$R_{\text{BOON}}$	–	–	1.4	$\Omega$	$I_{\text{BOI}} = 1\text{ A}$
Boost overcurrent threshold	$I_{\text{BOOC}}$	1.0	1.3	1.8	A	–
Feedback threshold voltage	$V_{\text{BOFBTH}}$	2.55	2.7	2.85	V	$V_{\text{BOI}} = 12\text{ V}$ $I_{\text{Boost}} = 25\text{ mA}$
Feedback input current	$I_{\text{FB}}$	– 2	– 0.4	0	$\mu\text{A}$	$2\text{ V} < V_{\text{BOFB}} < 4\text{ V}$

**Buck-Converter; BUO, BDS, BUC and  $V_{\text{CC}}$** 

Logic supply voltage	$V_{\text{CC}}$	4.9	–	5.1	V	$1\text{ mA} < I_{\text{CC}} < 250\text{ mA}$ ; see. appl. circuit
Efficiency; see. appl. circuit	$\eta$	–	85	–	%	$I_{\text{CC}} = 250\text{ mA}$ ; $V_{\text{Boost}} = 25\text{ V}$
Power-Stage ON resistance	$R_{\text{BUON}}$	–	0.38	0.5	$\Omega$	$T_j = 25\text{ }^{\circ}\text{C}$ ; $I_{\text{BUO}} = 1\text{ A}$
Power-Stage ON resistance	$R_{\text{BUON}}$	–	–	1.0	$\Omega$	$I_{\text{BUO}} = 1\text{ A}$
Buck overcurrent threshold	$I_{\text{BUOC}}$	0.7	0.95	1.2	A	–
Input current on pin $V_{\text{CC}}$	$I_{\text{CC}}$	–	0.2	0.5	mA	$V_{\text{CC}} = 5\text{ V}$

**Electrical Characteristics (cont'd)**

8 V <  $V_{\text{Boost}}$  < 35 V; 4.75 V <  $V_{\text{CC}}$  < 5.25 V;  $-40\text{ }^{\circ}\text{C} < T_j < 150\text{ }^{\circ}\text{C}$ ;  $R_R = 47\text{ k}\Omega$ ; all voltages with respect to ground; positive current defined flowing into pin; unless otherwise specified.

Parameter	Symbol	Limit Values			Unit	Test Conditions
		min.	typ.	max.		
Buck Gate supply voltage; $V_{\text{BGS}} = V_{\text{BDS}} - V_{\text{BUO}}$	$V_{\text{BGS}}$	5	–	10	V	–

**Reference Input; R  
(Oscillator; Timebase for Boost- and Buck-Converter, Reset and Watchdog)**

Voltage on pin R	$V_R$	1.3	1.4	1.5	V	–
Oscillator frequency	$f_{\text{OSC}}$	85	95	105	kHz	$T_j = 25\text{ }^{\circ}\text{C}$
Oscillator frequency	$f_{\text{OSC}}$	75	–	115	kHz	–
Cycle time for watchdog and reset timing	$t_{\text{CYL}}$	–	1.05	–	ms	$t_{\text{CYL}} = 100/f_{\text{OSC}}$

**Reset Generator; RO**

Reset threshold; $V_{\text{CC}}$ decreasing/increasing	$V_{\text{RT}}$	4.50	4.65	4.75	V	$V_{\text{RO}}$ H to L or L to H transition; $V_{\text{RO}}$ remains low down to $V_{\text{CC}} > 1\text{ V}$
Reset low voltage	$V_{\text{ROL}}$	–	0.2	0.4	V	$I_{\text{ROL}} = 2\text{ mA}$ ; $2.5\text{ V} < V_{\text{CC}} < V_{\text{RT}}$
Reset low voltage	$V_{\text{ROL}}$	–	0.2	0.4	V	$I_{\text{ROL}} = 0.2\text{ mA}$ ; $1\text{ V} < V_{\text{CC}} < V_{\text{RT}}$
Reset high voltage	$V_{\text{ROH}}$	$V_{\text{CC}} - 0.1$	–	$V_{\text{CC}} + 0.1$	V	$I_{\text{ROH}} = 0\text{ mA}$
Reset pull up current	$I_{\text{RO}}$	–	240	–	$\mu\text{A}$	$0\text{ V} < V_{\text{RO}} < 4\text{ V}$
Reset Reaction time	$t_{\text{RR}}$	50	100	150	$\mu\text{s}$	$V_{\text{CC}} < V_{\text{RT}}$
Power-up reset delay time	$t_{\text{RD}}$	–	64	–	$t_{\text{CYL}}$	$V_{\text{CC}} \geq 4.8\text{ V}$

**Electrical Characteristics (cont'd)**

8 V <  $V_{\text{Boost}}$  < 35 V; 4.75 V <  $V_{\text{CC}}$  < 5.25 V;  $-40\text{ }^{\circ}\text{C} < T_j < 150\text{ }^{\circ}\text{C}$ ;  $R_R = 47\text{ k}\Omega$ ; all voltages with respect to ground; positive current defined flowing into pin; unless otherwise specified.

Parameter	Symbol	Limit Values			Unit	Test Conditions
		min.	typ.	max.		

**Watchdog Generator; WDI**

H-input voltage threshold	$V_{\text{WDIH}}$	–	–	$0.7 \times V_{\text{CC}}$	V	–
L-input voltage threshold	$V_{\text{WDIL}}$	$0.3 \times V_{\text{CC}}$	–	–	V	–
Watchdog period	$T_{\text{WD}}$	–	128	–	$t_{\text{CYL}}$	$V_{\text{CC}} \geq 4.8\text{ V}$
Start of reset; after watchdog time-out	$t_{\text{SR}}$	–	64	–	$t_{\text{CYL}}$	$V_{\text{CC}} \geq 4.8\text{ V}$
Reset duration; after watchdog time-out	$t_{\text{WDR}}$	–	64	–	$t_{\text{CYL}}$	$V_{\text{CC}} \geq 4.8\text{ V}$
Open window time	$t_{\text{OW}}$	–	32	–	$t_{\text{CYL}}$	$V_{\text{CC}} \geq 4.8\text{ V}$
Closed window time	$t_{\text{CW}}$	–	32	–	$t_{\text{CYL}}$	$V_{\text{CC}} \geq 4.8\text{ V}$
Window watchdog trigger time	$t_{\text{WD}}$	–	46.4	–	$t_{\text{CYL}}$	$V_{\text{CC}} \geq 4.8\text{ V}$

**System Enable Output; SEN**

Enable low voltage	$V_{\text{SENL}}$	–	0.2	0.4	V	$I_{\text{SENL}} = 2\text{ mA}$ ; $2.5\text{ V} < V_{\text{CC}} < V_{\text{RT}}$
Enable low voltage	$V_{\text{SENL}}$	–	0.2	0.4	V	$I_{\text{SENL}} = 0.2\text{ mA}$ ; $1\text{ V} < V_{\text{CC}} < V_{\text{RT}}$
Enable high voltage	$V_{\text{SENH}}$	$V_{\text{CC}} - 0.1$	–	$V_{\text{CC}} + 0.1$	V	$I_{\text{SENH}} = 0\text{ mA}$
Enable pull up current	$I_{\text{SEN}}$	–	240	–	$\mu\text{A}$	$0\text{ V} < V_{\text{SEN}} < 4\text{ V}$

**Electrical Characteristics (cont'd)**

8 V <  $V_{\text{Boost}}$  < 35 V; 4.75 V <  $V_{\text{CC}}$  < 5.25 V;  $-40\text{ }^{\circ}\text{C} < T_j < 150\text{ }^{\circ}\text{C}$ ;  $R_{\text{R}} = 47\text{ k}\Omega$ ; all voltages with respect to ground; positive current defined flowing into pin; unless otherwise specified.

Parameter	Symbol	Limit Values			Unit	Test Conditions
		min.	typ.	max.		

**Boost Status Output; OVL**

Enable low voltage	$V_{\text{OVLL}}$	–	0.2	0.4	V	$I_{\text{OVLL}} = 1\text{ mA}$ ; $2.5\text{ V} < V_{\text{CC}} < V_{\text{RT}}$
Boost feedback threshold voltage;	$V_{\text{OVLTH}}$	2.3	2.45	2.6	V	See application circuit

**Thermal Shutdown (Boost and Buck-Converter OFF)**

Thermal shutdown junction temperature	$T_{\text{jSD}}$	150	175	200	$^{\circ}\text{C}$	–
Thermal switch-on junction temperature	$T_{\text{jSO}}$	120	–	170	$^{\circ}\text{C}$	–
Temperature hysteresis	$\Delta T$	–	30	–	K	–

*Note: The listed characteristics are ensured over the operating range of the integrated circuit. Typical characteristics specify mean values expected over the production spread. If not otherwise specified, typical characteristics apply at  $T_A = 25\text{ }^{\circ}\text{C}$  and the given supply voltage.*

### Circuit Description

Below some important sections of the TLE 6363 are described in more detail.

### Power On Reset

In order to avoid any system failure, a sequence of several conditions has to be passed. In case of  $V_{CC}$  power down ( $V_{CC} < V_{RT}$  for  $t > t_{RR}$ ) a logic LOW signal is generated at the pin RO to reset an external microcontroller. When the level of  $V_{CC}$  reaches the reset threshold  $V_{RT}$ , the signal at RO remains LOW for the Power-up reset delay time  $t_{RD}$  before switching to HIGH. If  $V_{CC}$  drops below the reset threshold  $V_{RT}$  for a time extending the reset reaction time  $t_{RR}$ , the reset circuit is activated and a power down sequence of period  $t_{RD}$  is initiated. The reset reaction time  $t_{RR}$  avoids wrong triggering caused by short “glitches” on the  $V_{CC}$ -line.

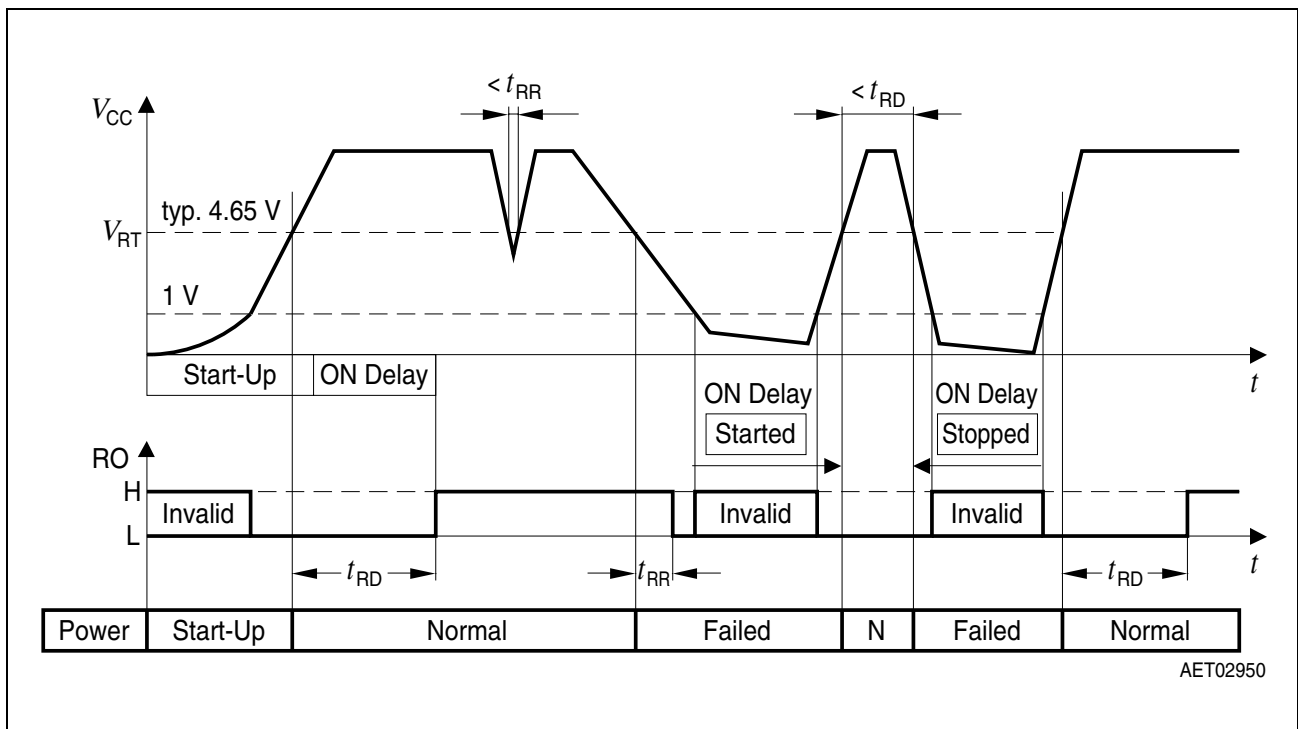

Figure 3 Reset Function

## Watchdog Operation

The watchdog uses one hundred of the oscillator's clock signal period as a timebase, defined as the watchdog cycle time  $t_{CYL}$ .

After power-on, the reset output signal at the RO pin (microcontroller reset) is kept LOW for the reset delay time  $t_{RD}$ , i.e. 64 cycles. With the LOW to HIGH transition of the signal at RO the device starts the closed window time  $t_{CW} = 32$  cycles. A trigger signal within this window is interpreted as a pretrigger failure according to the figures shown below. After the closed window the open window with the duration  $t_{OW}$  is started. The open window lasts at minimum until the trigger process has occurred, at maximum  $t_{OW}$  is 32 cycles.

A HIGH to LOW transition of the watchdog trigger signal on pin WDI is taken by a trigger. To avoid wrong triggering due to parasitic glitches two HIGH samples followed by two LOW samples (sample period  $t_{CYL}$ ) are decoded as a valid trigger. If a trigger signal appears at the watchdog input pin WDI during the open window or a power up/down occurs, the watchdog window signal is reset and a new closed window follows.

A reset is generated (RO goes LOW) if there is no trigger pulse during the open window or if a pretrigger occurs during the closed window. This reset happens after 64 cycles after the latest valid closed window start time and lasts for further 64 cycles.

The triggering is correct also, if the first three samples (two HIGH one LOW) of the trigger pulse at pin WDI are inside the closed window and only the fourth sample (the second LOW sample) is taken in the open window.

In addition to the microcontroller reset signal RO the device generates a system enable signal at pin SEN. If RO is HIGH the system enable goes active HIGH with the first valid watchdog trigger pulse at pin WDI. The SEN output goes LOW immediately if a pretrigger, a missing trigger or a power down reset occurs.

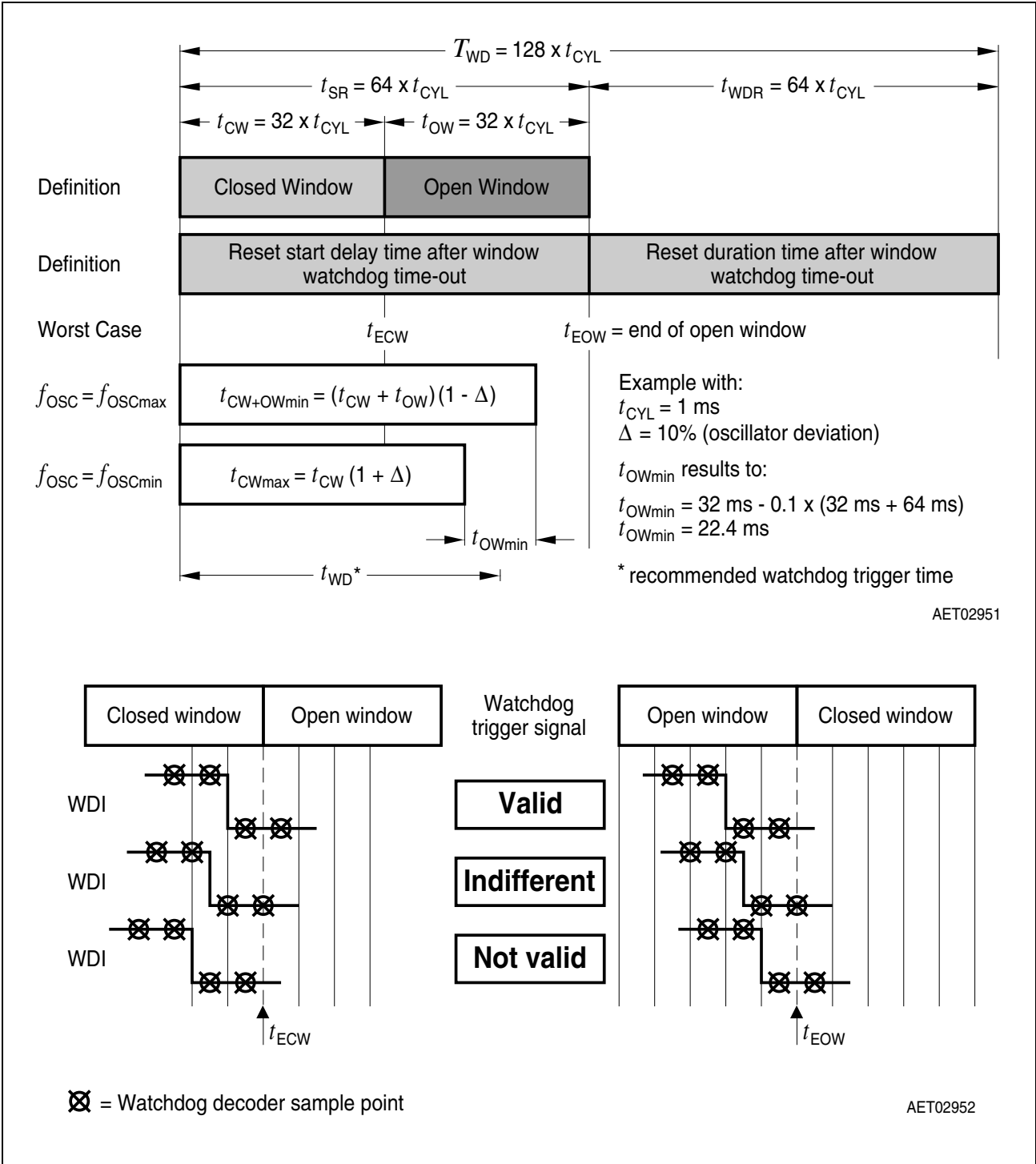

Figure 4 Window Watchdog Definitions

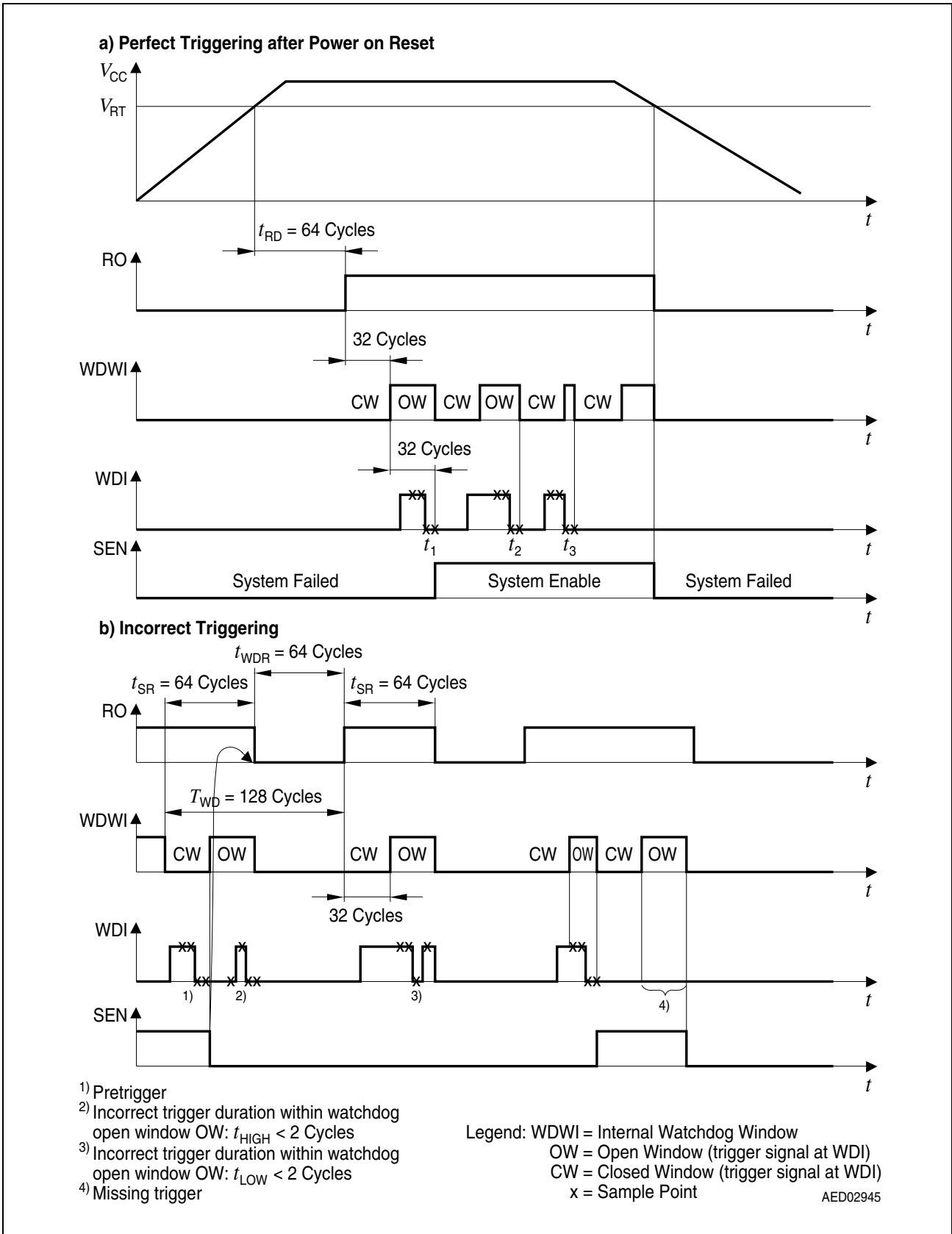

Figure 5 Window Watchdog Function

## Boost Converter

The TLE 6363 contains a fully integrated boost converter (except the boost-diode), which provides a supply voltage for an energy reserve e.g. an airbag firing system. The regulated boost output voltage  $V_{\text{BOOST}}$  is programmable by a divider network (external resistors) providing the feedback voltage for the boost feedback pin BOFB. The energy which is stored in the external electrolytic capacitor at  $V_{\text{BOOST}}$  guarantees accurate airbag firing, even if the battery is disconnected by a car crash.

The boost inductance  $L_{\text{BO}}$  (typ. 100  $\mu\text{H}$ ) is PWM-switched by an integrated current limited power DMOS transistor with a programmable (external resistor  $R_{\text{R}}$ ) frequency. An internal bandgap reference provides a temperature independent, on chip trimmed reference voltage for the regulation loop. An error amplifier compares the reference voltage with the boost feedback signal  $V_{\text{BOFB}}$  from the external divider network (determination of the output boost voltage  $V_{\text{BOOST}}$ ).

Application note for programming the output voltage at pin  $V_{\text{BOOST}}$ :

$$V_{\text{BOOST}} = V_{\text{BOFBTH}} \times \frac{(R_{\text{BO1}} + R_{\text{BO2}})}{R_{\text{BO2}}}$$

With a PWM (Pulse Width Modulation) comparator the output of the error amplifier is compared to a periodic linear ramp, provided by a sawtooth signal of the oscillator connected to pin R. A logic signal with variable pulse width is generated. It passes through the logic circuits (sets the output latch PWM-FF) and driver circuits to the power switching DMOS. The Schmitt-trigger output resets the output flip-flop PWM-FF by NOR 2. The PWM signal is gated by the NAND 2 to guarantee a dominant reset.

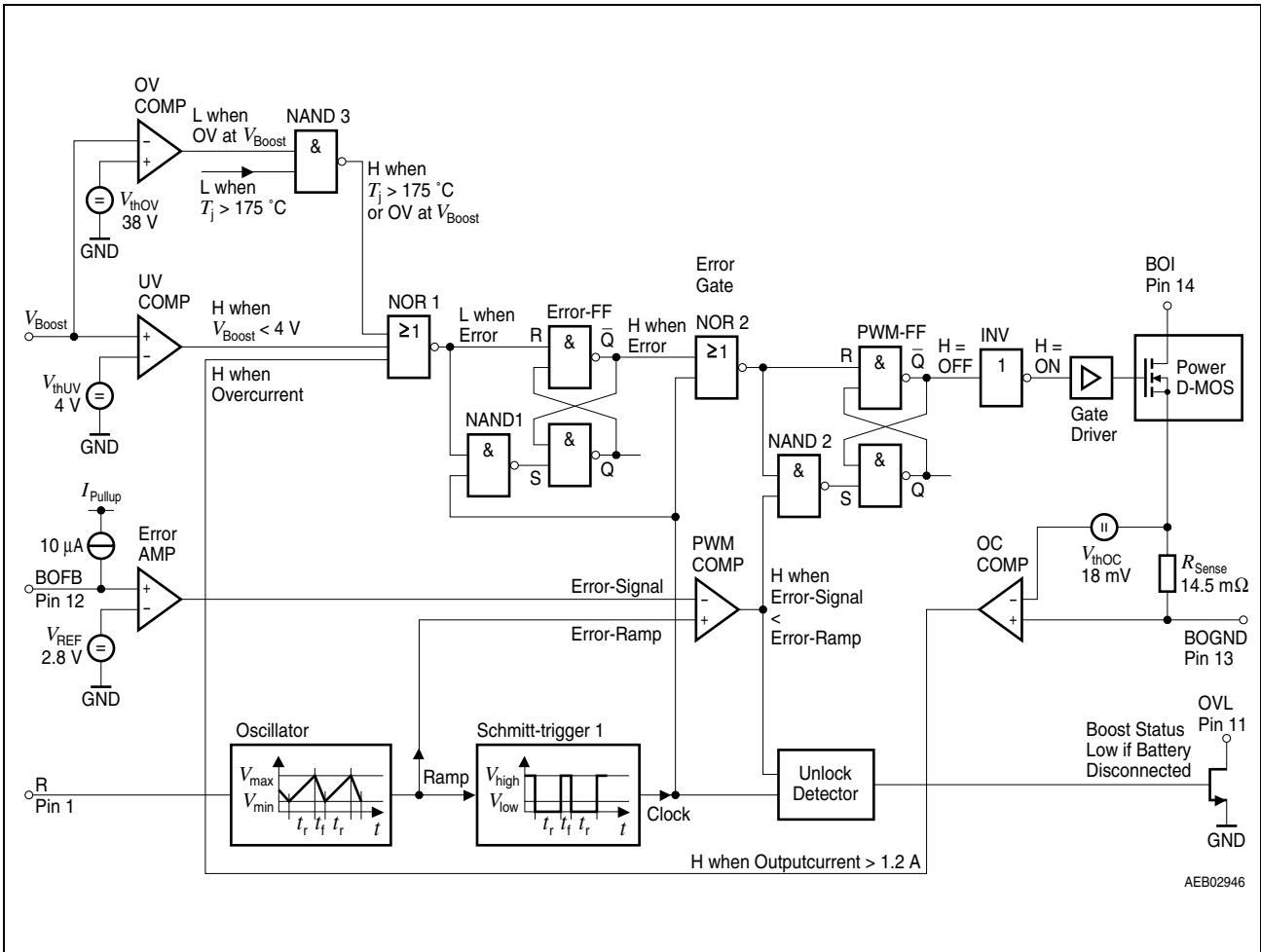

**Figure 6 Boost Converter Block Diagram**

**Figure 7** shows the most important waveforms during operation; for low, medium and high loads up to overload condition. The output transistor is switched off immediately if the overcurrent comparator detects an overcurrent level at the power DMOS or if the sense output switches to low induced by a  $V_{BOOST}$  undervoltage command.

The **TLE 6363** is also protected against several boost loop errors:

In case of a feedback interruption a pull up current source ( $I_{FB}$  typ.  $0.4 \mu A$ ), integrated at pin BOFB pulls the voltage at the feedback pin BOFB above the reference voltage. The boost output is switched off by the high error voltage which controls the PWM-Comparator at a zero duty cycle.

In the case of a resistive loop error caused by leakage currents to ground, the boost output voltage would increase to very high values. In order to protect the  $V_{BOOST}$  input as well as the external load against catastrophic failures, an overvoltage protection is provided which switches the output transistor off as soon as the voltage at pin  $V_{BOOST}$  exceeds the internal fixed overvoltage threshold  $V_{BOOV OFF} = \text{typ. } 37 \text{ V}$ .

Application Note:

A short circuit from  $V_{\text{BOOST}}$  to ground will not destroy the IC, however, it may damage the external boost diode or the boost inductance if there is no overcurrent limitation in that path.

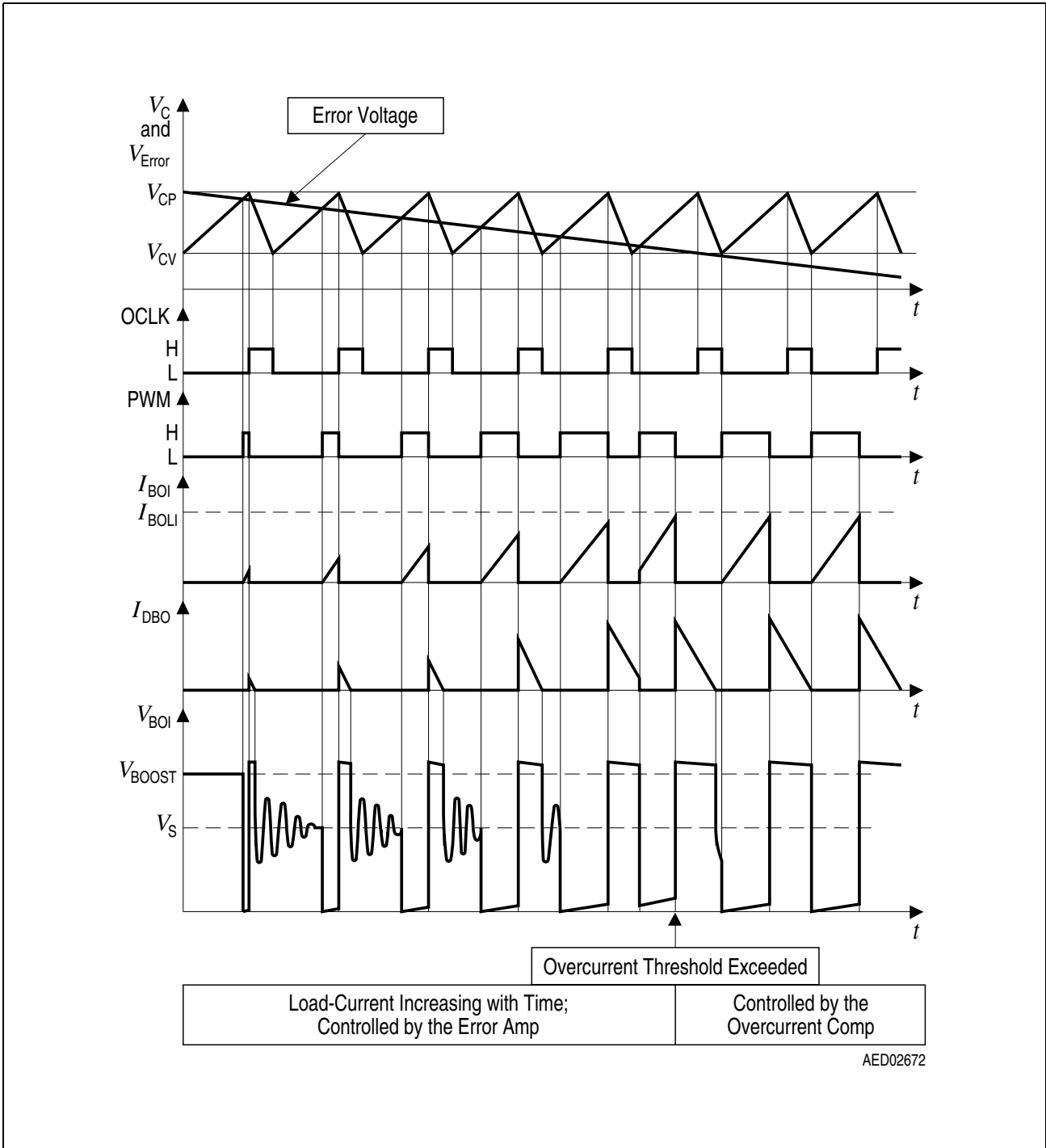

Figure 7 Most Important Waveforms of the Boost Converter Circuit

## Buck Converter

A stabilized logic supply voltage (typ. 5 V) for general purpose is realized in the system by a buck converter. An external buck-inductance  $L_{BU}$  is PWM switched by a high side DMOS power transistor with the programmed frequency (pin R).

The buck regulator supply is given by the boost converter output  $V_{BOOST}$ , in case of a battery power-down the stored energy of the boost converter capacitor is used.

Like the boost converter, the buck converter uses the temperature compensated bandgap reference voltage (typ. 2.8 V) for its regulation loop.

This reference voltage is connected to the non-inverting input of the error amplifier and an internal voltage divider supplies the inverting input. Therefore the output voltage  $V_{CC}$  is fixed due to the internal resistor ratio to typ. 5.0 V.

The output of the error amplifier goes to the inverting input of the PWM comparator as well as to the buck compensation output BUC.

When the error amplifier output voltage exceeds the sawtooth voltage the output power MOS-transistor is switched on. So the duration of the output transistor conduction phase depends on the  $V_{CC}$  level. A logic signal PWM with variable pulse width is generated.

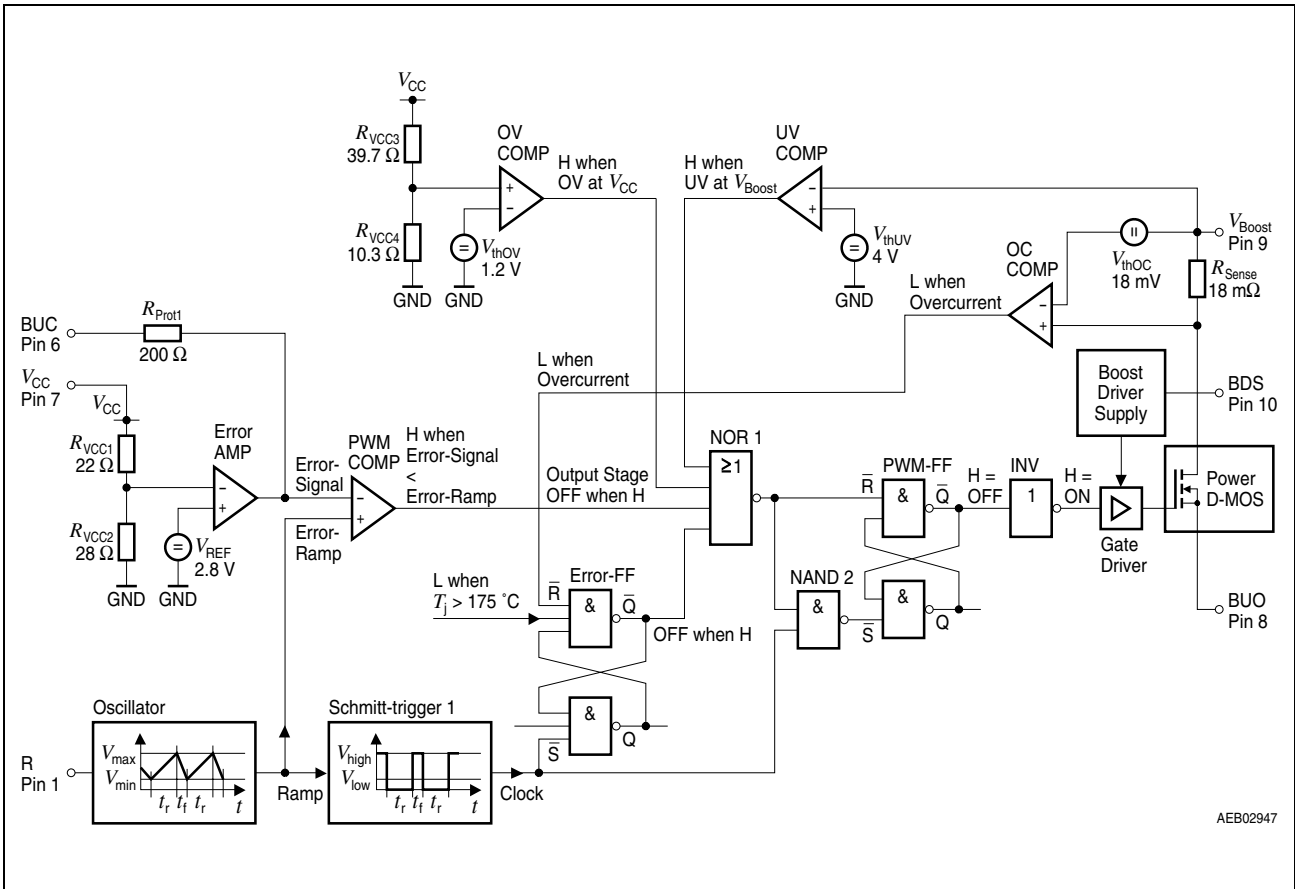
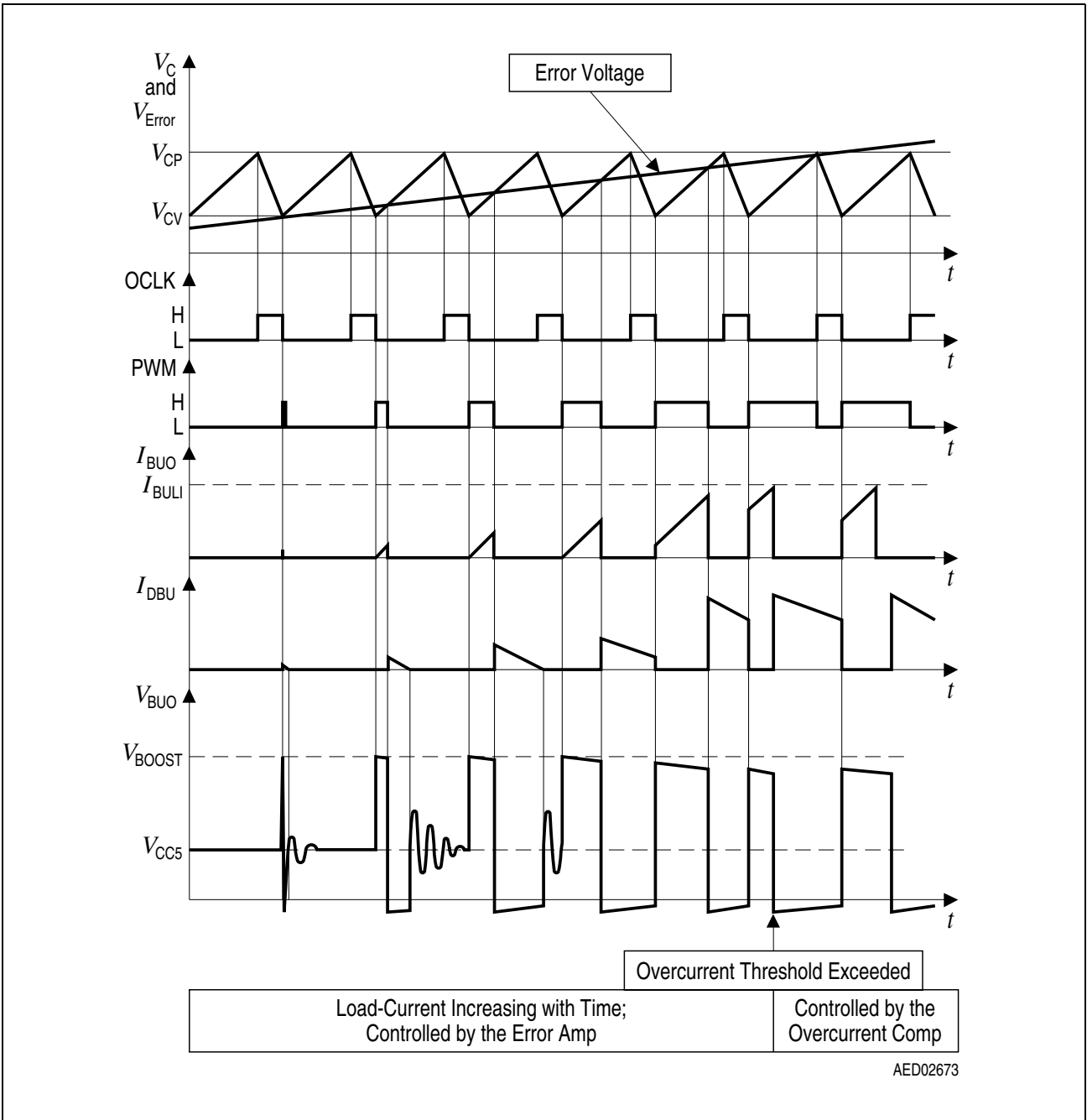

**Figure 8 Buck Converter Block Diagram**

External loop compensation is required for converter stability, and is formed by connecting a compensation resistor-capacitor series-network ( $R_{BUC}, C_{BUC}$ ) between pin BUC and GND.

In the case of overload or short-circuit at  $V_{CC}$  (the output current exceeds the buck overcurrent threshold  $I_{BUOC}$ ) the DMOS output transistor is switched off by the overcurrent comparator immediately. The pulse width is then controlled by the overcurrent comparator as seen before in the boost description.

In order to protect the  $V_{CC}$  input as well as the external load against catastrophic failures, an overvoltage protection is provided which switches the output transistor off as soon as the voltage at pin  $V_{CC}$  exceeds the internal fixed overvoltage threshold  $V_{BUOVOFF} = \text{typ. } 6.0 \text{ V}$ .



**Figure 9 Most Important Waveforms of the Buck Converter Circuit**

### Application Circuit

Figure 10 shows the application circuit of the TLE 6363 with the suggested external parts.

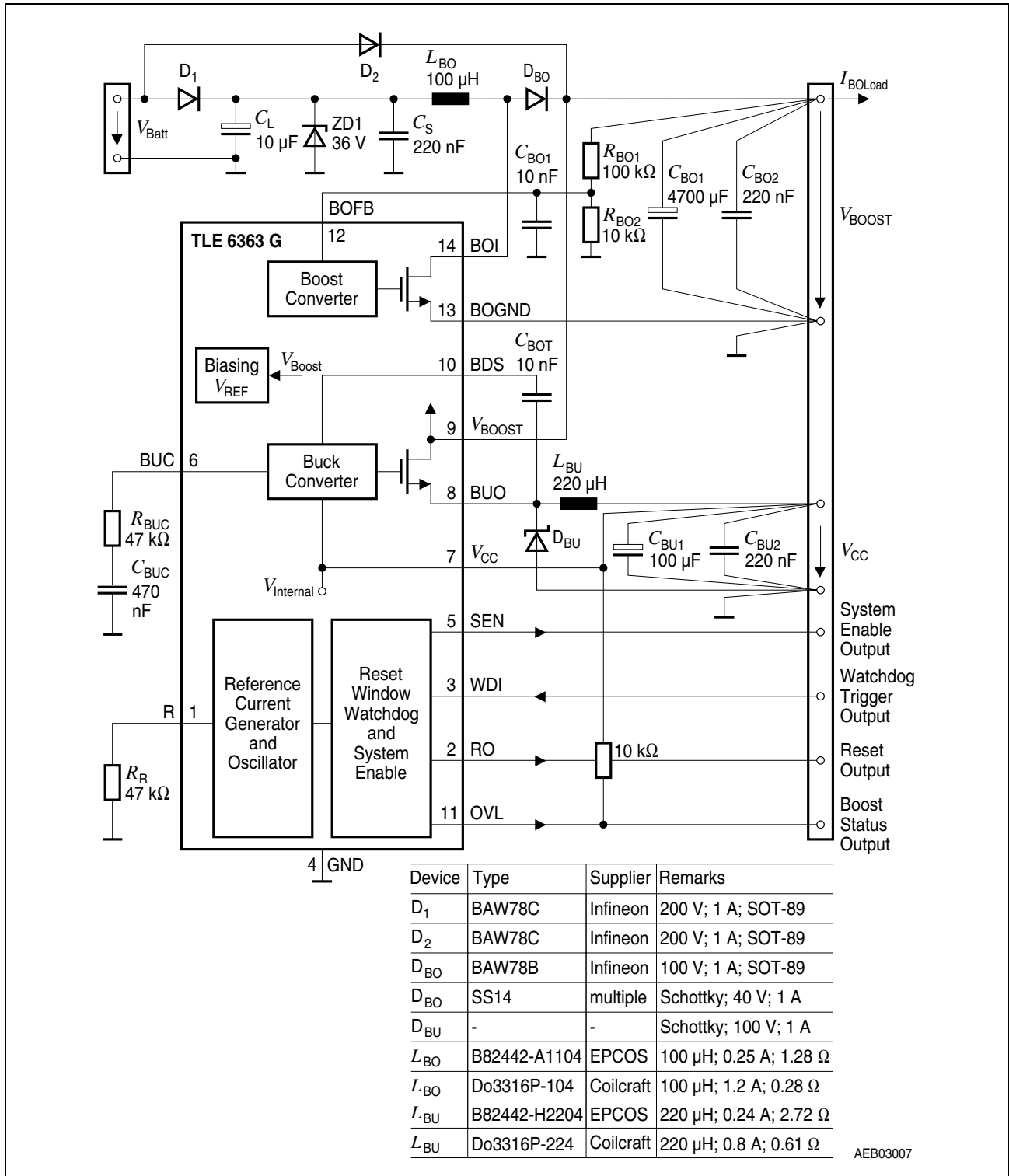
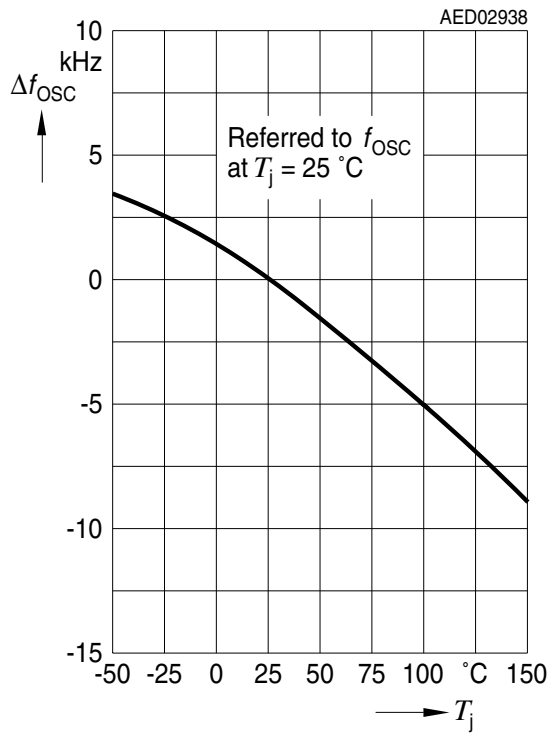

Figure 10 Application Circuit

**Diagrams: Oscillator and Boost/Buck-Converter Performance**

In the following the behaviour of the Boost/Buck-converter and the oscillator is shown.

**Oscillator Frequency Deviation vs. Junction Temperature**



**Boost Feedback Current vs. Junction Temperature**

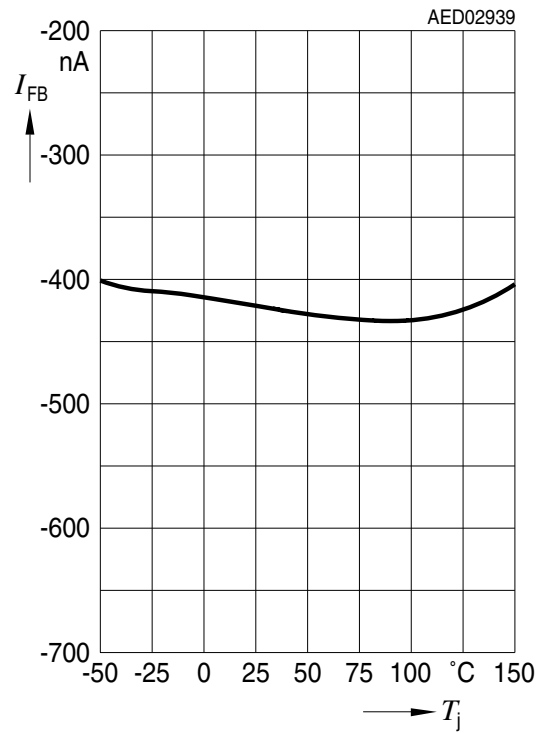

**Current Consumption vs. Junction Temperature**

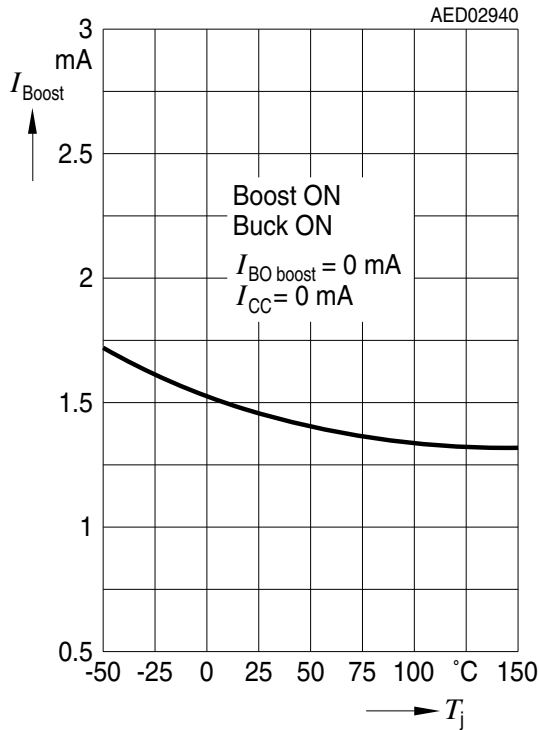

**Efficiency Buck vs. Boost Voltage**

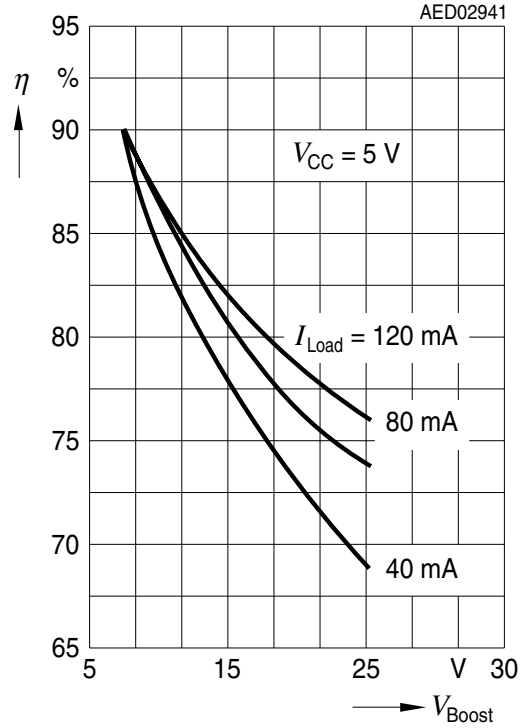

**Efficiency Buck vs. Load**

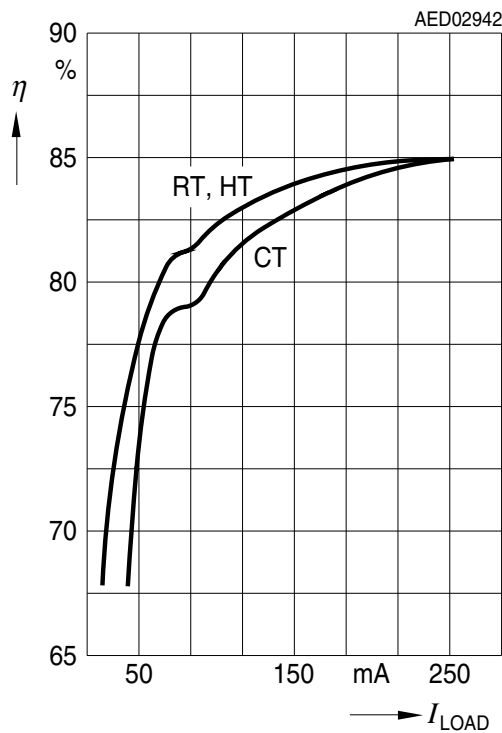

**Efficiency Boost vs. Input Voltage**

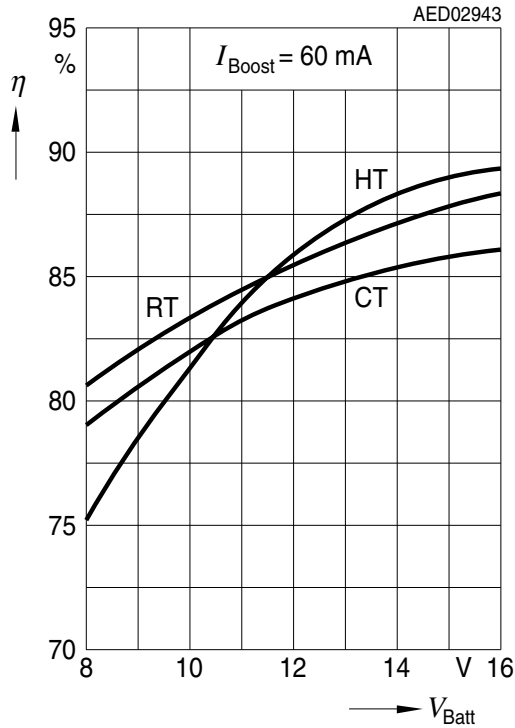

**Boost Output Voltage vs. Load**

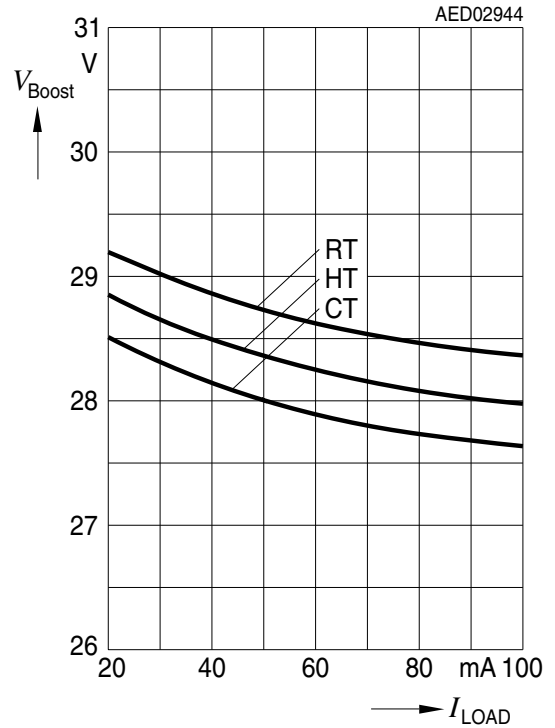

**Oscillator Frequency vs. Resistor from R to GND**

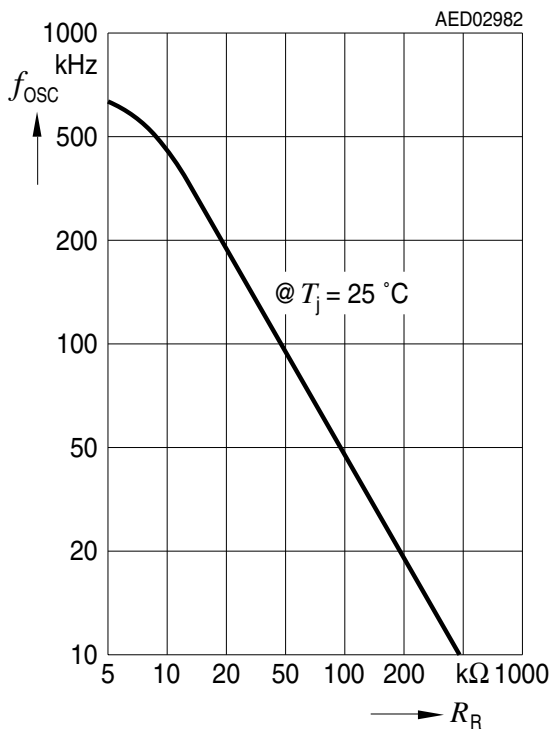

**Boost and Logic Output Voltage vs. Junction Temperature**

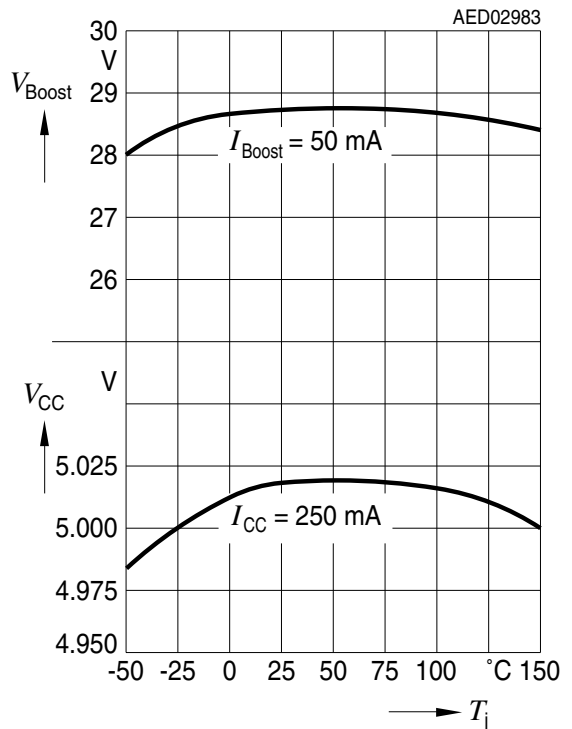

### Boost and Buck ON Resistance vs. Junction Temperature

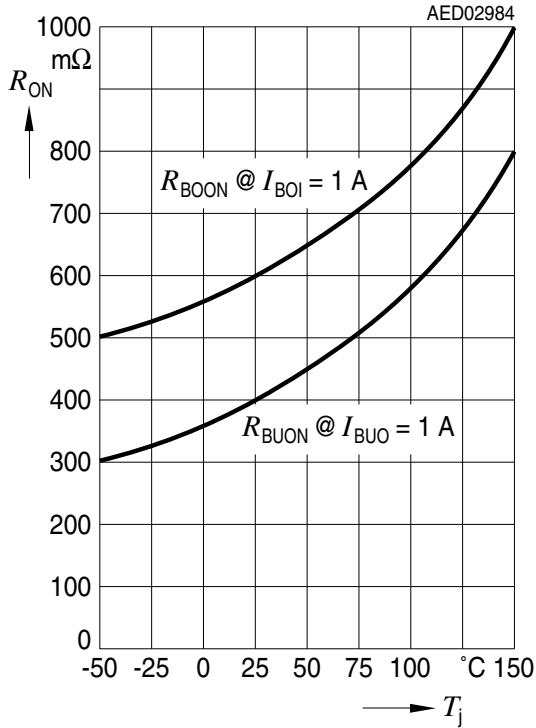

### Boost and Buck Overcurrent Threshold vs. Junction Temperature

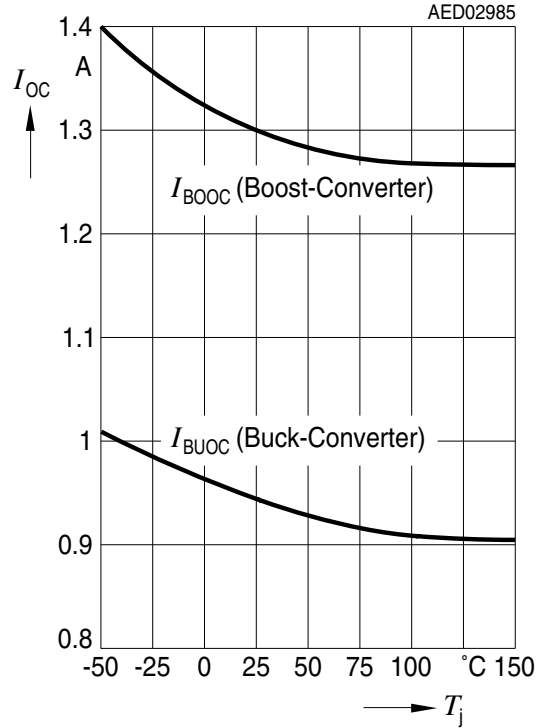

Package Outlines

**P-DSO-14-2**  
(Plastic Dual Small Outline Package)

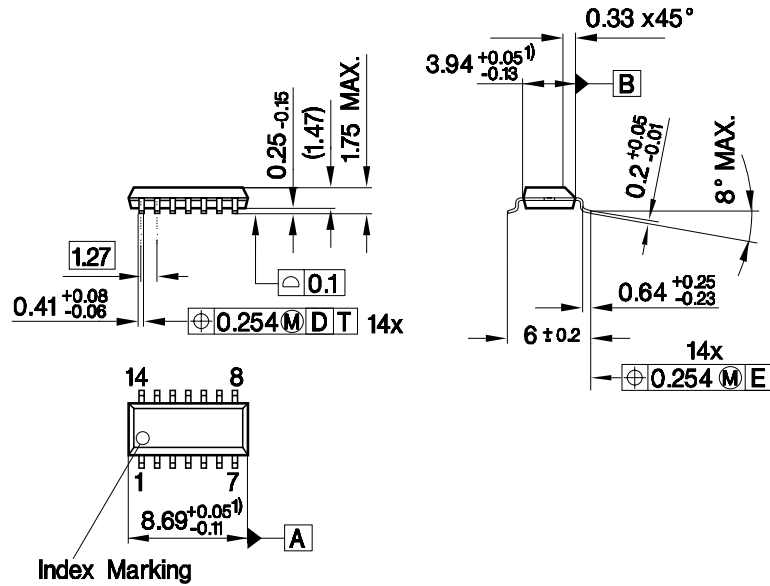

1) Does not include plastic or metal protrusion of 0.15 max. per side

GPS05474

**Sorts of Packing**

Package outlines for tubes, trays etc. are contained in our Data Book "Package Information"

SMD = Surface Mounted Device

Dimensions in mm

**Edition 2003-06-02**

**Published by Infineon Technologies AG,  
St.-Martin-Strasse 53,  
D-81541 München, Germany**

**© Infineon Technologies AG 2003.  
All Rights Reserved.**

**Attention please!**

The information herein is given to describe certain components and shall not be considered as warranted characteristics.

Terms of delivery and rights to technical change reserved.

We hereby disclaim any and all warranties, including but not limited to warranties of non-infringement, regarding circuits, descriptions and charts stated herein.

Infineon Technologies is an approved CECC manufacturer.

**Information**

For further information on technology, delivery terms and conditions and prices please contact your nearest Infineon Technologies Office in Germany or our Infineon Technologies Representatives worldwide (see address list).

**Warnings**

Due to technical requirements components may contain dangerous substances. For information on the types in question please contact your nearest Infineon Technologies Office.

Infineon Technologies Components may only be used in life-support devices or systems with the express written approval of Infineon Technologies, if a failure of such components can reasonably be expected to cause the failure of that life-support device or system, or to affect the safety or effectiveness of that device or system. Life support devices or systems are intended to be implanted in the human body, or to support and/or maintain and sustain and/or protect human life. If they fail, it is reasonable to assume that the health of the user or other persons may be endangered.

## Looking for pricing, stock, or lifecycle information?

Click below to explore more details on WIN SOURCE:

- ⊖ [View TLE6363G on WIN SOURCE](#)
- ⊖ [Infineon Technologies Information](#)

## Optimize Your Supply Chain with WIN SOURCE Solutions

- ✓ Global Sourcing Solution
- ✓ Obsolete Management
- ✓ Cost Control Management
- ✓ Shortage Management
- ✓ Alternative Solution
- ✓ Excess Inventory Management