



THE DATASHEET OF TPS65146RGER



Compact LCD Bias IC with LDO, VCOM Buffer and Reset Function

FEATURES

- 2.5V to 6.0V Input Voltage Range
- Up to 16.5V Boost Converter With 2A Switch Current
- 650kHz/1.2MHz Selectable Switching Frequency
- Adjustable Soft-Start for the Boost Converter
- 500mA LDO
- Reset Function ($\overline{\text{XAO}}$ Signal)
- Regulated VGH
- Gate Voltage Shaping
- VCOM Buffer

- LCD Discharge Function
- Overvoltage Protection
- Thermal Shutdown
- Undervoltage Lockout
- 24-Pin 4x4mm QFN Package

APPLICATIONS

- Notebook PC
- Monitor

DESCRIPTION

The TPS65146 offers a very compact power supply solution designed to supply the LCD bias voltages required by TFT (Thin Film Transistor) LCD panels running from a typical 3.3 V or 5 V supply rail. The device integrates a step-up converter for V_S (Source Driver voltage), a positive charge pump regulator for V_{GH} (Gate Driver High voltage), a logic voltage rail using an integrated LDO and a VCOM buffer driving the LCD backplane. In addition to that, a gate voltage shaping block is integrated for V_{GH} , modulating the signal (into V_{GHM}) with high flexibility by using a logic input VFLK and an external discharge resistor connected to RE pin. Also, an external discrete negative charge pump can be set using the boost converter of the TPS65146 to generate V_{GL} (Gate Driver Low voltage). The integrated reset function together with the LCD discharge function available in the TPS65146 provide the signals enabling the discharge of the LCD TFT pixels when powering-off. The device includes safety features like overvoltage protection (OVP), as well as thermal shutdown.

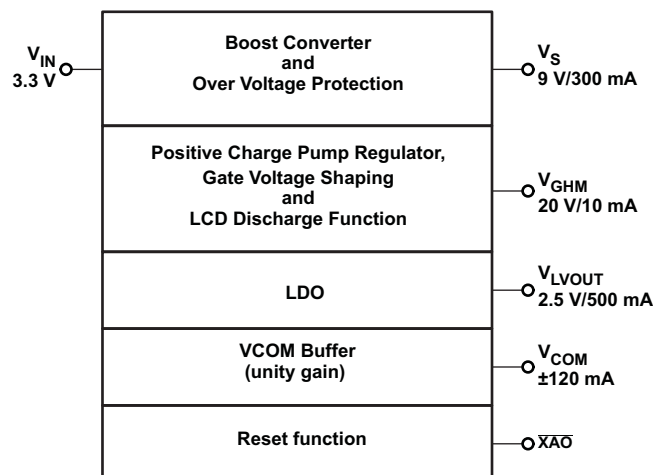

Please be aware that an important notice concerning availability, standard warranty, and use in critical applications of Texas Instruments semiconductor products and disclaimers thereto appears at the end of this data sheet.

TPS65146

SLVS869A–NOVEMBER 2008–REVISED JUNE 2009

www.ti.com

These devices have limited built-in ESD protection. The leads should be shorted together or the device placed in conductive foam during storage or handling to prevent electrostatic damage to the MOS gates.

ORDERING INFORMATION⁽¹⁾

T _A	ORDERING	PACKAGE	PACKAGE MARKING
–40°C to 85°C	TPS65146RGER	24-pin QFN	CEZ

- (1) The RGE package is available taped and reeled. For the most current package and ordering information, see the Package Option Addendum at the end of this document, or see the TI website www.ti.com.

ABSOLUTE MAXIMUM RATINGS

over operating free-air temperature range (unless otherwise noted) ⁽¹⁾

	VALUE	UNIT
Input voltage range V _{IN} , LV _{IN} ⁽²⁾	–0.3 to 6.5	V
Voltage range on pins FB, SS, FREQ, COMP, ADJ, LV _{OUT} , $\overline{\text{XAO}}$, FBP, VDPM, VFLK, VDET, CDET ⁽²⁾	–0.3 to 6.5	V
Voltage on pin SW, OPI, OPO, SUP, DRVP ⁽²⁾	–0.3 to 20	V
Input voltage on VG _H , VG _{HM} , RE ⁽²⁾	–0.3 to 35	V
ESD rating HBM	2	kV
ESD rating MM	200	V
ESD rating CDM	500	V
Continuous power dissipation	See Dissipation Rating Table	
Storage temperature range	–65 to 150	°C

- (1) Stresses beyond those listed under *absolute maximum ratings* may cause permanent damage to the device. These are stress ratings only, and functional operation of the device at these or any other conditions beyond those indicated under *recommended operating conditions* is not implied. Exposure to absolute-maximum-rated conditions for extended periods may affect device reliability.
- (2) All voltage values are with respect to network ground terminal.

DISSIPATION RATINGS⁽¹⁾⁽²⁾

PACKAGE	R _{θJA}	T _A ≤ 25°C POWER RATING	T _A = 70°C POWER RATING	T _A = 85°C POWER RATING
QFN	30°C/W	3.3 W	1.8 W	1.3 W

- (1) $P_D = (T_J - T_A)/R_{\theta JA}$.
- (2) R_{θJA}, given for High-K PCB board.

RECOMMENDED OPERATING CONDITIONS⁽¹⁾⁽²⁾

over operating free-air temperature range (unless otherwise noted)

	MIN	TYP	MAX	UNIT
V _{IN} , V _{LVIN} Input voltage range, with V _{LVIN} ≤ V _{IN}	2.5		6.0	V
T _A Operating ambient temperature	–40		85	°C
T _J Operating junction temperature	–40		125	°C

- (1) Maximum output voltage limited by the Overvoltage Protection and not the maximum Power Switch rating.
- (2) Refer to application section for further information

ELECTRICAL CHARACTERISTICS

$V_{IN} = V_{LVIN} = 3.3\text{ V}$, $V_S = V_{SUP} = 9\text{ V}$, $V_{LVOUT} = 2.5\text{ V}$, $V_{GH} = 20\text{ V}$, $T_A = -40^\circ\text{C}$ to 85°C , typical values are at $T_A = 25^\circ\text{C}$ (unless otherwise noted)

PARAMETER		TEST CONDITIONS	MIN	TYP	MAX	UNIT
SUPPLY						
V_{IN}	Input voltage range		2.5		6.0	V
I_{QIN}	Operating quiescent current into VIN	Device not switching, $V_{FB} = 1.240\text{ V} + 3\%$		0.17	0.5	mA
I_{QLVIN}	Operating quiescent current into LVIN	$V_{ADJ} = 1.240\text{ V}$, $V_{LVOUT} = \text{open}$, no load		25	45	μA
I_{QVGH}	Operating quiescent current into VGH	$V_{FLK} = \text{GND}$		22	40	μA
I_{QSUP}	Operating quiescent current into SUP	Device not switching, $V_{FB} = 1.240\text{ V} + 3\%$		1.8		mA
I_{SDVIN}	Shutdown current into VIN	$V_{IN} = 1.8\text{ V}$, $V_S = \text{GND}$		20	33	μA
I_{SDVGH}	Shutdown current into VGH	$V_{IN} = 1.8\text{ V}$, $V_{GH} = 32\text{ V}$		30	50	μA
I_{SDLVIN}	Shutdown current into LVIN	$V_{IN} = 1.8\text{ V}$, $V_{LVOUT} = \text{open}$		0.1	2	μA
I_{SDSUP}	Shutdown current into SUP	$V_{IN} = 1.8\text{ V}$, $V_{SUP} = 16.5\text{ V}$		3	5	μA
V_{UVLO}	Under-voltage lockout threshold	V_{IN} falling	2.0		2.2	V
		V_{IN} rising			2.3	
T_{SD}	Thermal shutdown	Temperature rising		150		$^\circ\text{C}$
T_{SDHYS}	Thermal shutdown hysteresis			14		$^\circ\text{C}$
LOGIC SIGNALS FREQ, VFLK						
I_{LEAK}	Input leakage current	$V_{FLK} = 6.0\text{ V}$, $\text{FREQ} = \text{GND}$			0.1	μA
V_{IH}	Logic high input voltage	$V_{IN} = 2.5\text{ V}$ to 6 V	2			V
V_{IL}	Logic low input voltage	$V_{IN} = 2.5\text{ V}$ to 6 V			0.5	V
BOOST CONVERTER						
V_S	Output voltage boost converter ⁽¹⁾		7		16.5	V
V_{OVP}	Overvoltage protection	V_S rising	16.9	18	19	V
V_{FB}	Feedback regulation voltage	$T_A = -40^\circ\text{C}$ to 85°C	1.226	1.240	1.254	V
		$T_A = 25^\circ\text{C}$	1.230	1.240	1.250	
I_{FB}	Feedback input bias current	$V_{FB} = 1.240\text{ V}$			0.1	μA
gm	Transconductance error amplifier gain			115		$\mu\text{A/V}$
$R_{DS(ON)}$	N-channel MOSFET on-resistance	$V_{IN} = V_{GS} = 5\text{ V}$, $I_{SW} = \text{current limit}$		0.13	0.38	Ω
		$V_{IN} = V_{GS} = 3.3\text{ V}$, $I_{SW} = \text{current limit}$		0.15	0.44	
I_{LEAK_SW}	SW leakage current	$V_{IN} = 1.8\text{ V}$, $V_{SW} = 17\text{ V}$			30	μA
I_{LIM}	N-Channel MOSFET current limit		2.0	2.5	3.0	A
I_{SS}	Softstart current	$V_{SS} = 1.240\text{ V}$		4		μA
f_{osc}	Switching frequency	$\text{FREQ} = \text{high}$	0.9	1.2	1.5	MHz
		$\text{FREQ} = \text{low}$	470	625	780	
I_{FREQ}	FREQ sink current	$\text{FREQ} = 3.3\text{ V}$		4		μA
	Line regulation	$V_{IN} = 2.5\text{ V}$ to 6.0 V , $I_{OUT} = 10\text{ mA}$		0.008		%/V
	Load regulation	$I_{OUT} = 0\text{ A}$ to 500 mA , $V_{IN} = 3.3\text{ V}$		0.15		%/A
LDO REGULATOR						
V_{LVOUT}	LDO output voltage range		1.240		4	V
V_{ADJ}	Feedback regulation voltage	$I_{LVOUT} = 2\text{ mA}$, $V_{LVOUT} = 1.240\text{ V}$, $T_A = -40^\circ\text{C}$ to 85°C	1.222	1.240	1.258	V
		$I_{LVOUT} = 2\text{ mA}$, $V_{LVOUT} = 1.240\text{ V}$, $T_A = 25^\circ\text{C}$	1.225	1.240	1.255	
I_{ADJ}	Feedback input bias current	$V_{ADJ} = 1.240\text{ V}$			0.1	μA
I_{SC_LDO}	Short circuit current limit	$V_{IN} = V_{LVIN} = 6\text{ V}$, $V_{LVOUT} = \text{GND}$, $\text{ADJ} = \text{GND}$			750	mA
V_{DO}	Dropout voltage	$I_{LVOUT} = 350\text{ mA}$, $V_{LVIN} = V_{LVOUT} - 0.1\text{ V}$		280	410	mV
		$I_{LVOUT} = 500\text{ mA}$, $V_{LVIN} = V_{LVOUT} - 0.1\text{ V}$		430	620	
	Line regulation	$V_{LVIN} = 2.7\text{ V}$ to 5.5 V , $I_{LVOUT} = 100\text{ mA}$		0.005		%/V
	Load regulation	$I_{LVOUT} = 1\text{ mA}$ to 300 mA		0.6		%/A

(1) Maximum output voltage limited by the Overvoltage Protection and not the maximum power switch rating of the boost converter.

ELECTRICAL CHARACTERISTICS (continued)
 $V_{IN} = V_{LVIN} = 3.3\text{ V}$, $V_S = V_{SUP} = 9\text{ V}$, $V_{LVOUT} = 2.5\text{ V}$, $V_{GH} = 20\text{ V}$, $T_A = -40^\circ\text{C}$ to 85°C , typical values are at $T_A = 25^\circ\text{C}$ (unless otherwise noted)

PARAMETER		TEST CONDITIONS	MIN	TYP	MAX	UNIT
VGH REGULATOR						
f_{SW}	Switching frequency		0.5 × f_{OSC}			MHz
V_{FBP}	Reference voltage of feedback	$T_A = -40^\circ\text{C}$ to 85°C	1.210	1.240	1.270	V
		$T_A = 25^\circ\text{C}$	1.221	1.240	1.259	
I_{FBP}	Feedback input bias current	$V_{FBP} = 1.240\text{ V}$			0.1	μA
$R_{DS(ON)Q1}$	DRVVP $R_{DS(ON)}$ (Q1 PMOS)	$V_S = 9\text{ V}$, $I_{DRVVP} = 40\text{ mA}$		8	20	Ω
$R_{DS(ON)Q2}$	DRVVP $R_{DS(ON)}$ (Q2 NMOS)	$V_S = 9\text{ V}$, $I_{DRVVP} = -40\text{ mA}$		2	6	Ω
GATE VOLTAGE SHAPING VGHM						
I_{DPM}	Capacitor charge current VDPM pin			20		μA
$R_{DS(ON)M1}$	VGH to VGHM $R_{DS(ON)}$ (M1 PMOS)	VFLK = low, $I_{VGHM} = 20\text{ mA}$, $V_{GH} = 20\text{ V}$		13	25	Ω
$R_{DS(ON)M2}$	VGHM to RE $R_{DS(ON)}$ (M2 PMOS)	VFLK = high, $I_{VGHM} = 20\text{ mA}$, $V_{GH} = 7.5\text{ V}$		13	25	Ω
RESET FUNCTION						
V_{IN_DET}	Operating voltage for V_{IN}		1.6		6.0	V
V_{DET}	Threshold voltage	Falling, $T_A = -40^\circ\text{C}$ to 85°C	1.074	1.100	1.126	V
		Falling, $T_A = 25^\circ\text{C}$	1.079	1.100	1.121	
V_{DET_HYS}	Threshold hysteresis			65		mV
I_{DET_B}	Input bias current	$V_{DET} = 1.1\text{ V}$			0.1	μA
I_{CDET}	Delay capacitor charge current	$V_{CDET} \leq 1.240\text{ V}$		10		μA
$I_{\overline{XAO}(ON)}$	Sink current capability ⁽²⁾	$V_{\overline{XAO}(ON)} = 0.5\text{ V}$	1			mA
$V_{\overline{XAO}(ON)}$	Low voltage level	$I_{\overline{XAO}(ON)} = 1\text{ mA}$			0.5	V
I_{LEAK_XAO}	Leakage current	$V_{\overline{XAO}} = V_{IN} = 3.3\text{V}$			2	μA
VCOM BUFFER						
V_{SUP}	V_S supply range ⁽³⁾		7		16.5	V
V_{OFFSET}	Input offset voltage	$V_{CM} = V_{OPI} = V_{SUP}/2 = 4.5\text{ V}$	-15		15	mV
I_B	Input bias current	$V_{CM} = V_{OPI} = V_{SUP}/2 = 4.5\text{ V}$	-1		1	μA
V_{CM}	Common mode input voltage range	$V_{OFFSET} = 10\text{ mV}$, $I_{OPO} = 10\text{ mA}$	2		$V_S - 2$	V
CMRR	Common mode rejection ratio	$V_{CM} = V_{OPI} = V_{SUP}/2 = 4.5\text{ V}$, 1 MHz		66		dB
V_{OL}	Output voltage swing low	$I_{OPO} = 10\text{ mA}$		0.10	0.20	V
V_{OH}	Output voltage swing high	$I_{OPO} = 10\text{ mA}$	$V_S - 0.80$	$V_S - 0.65$		V
I_{sc}	Short circuit current	Source ($V_{OPI} = V_{SUP}/2 = 4.5\text{ V}$, $OPO = \text{GND}$)	90	135		mA
		Sink ($V_{OPI} = V_{SUP}/2 = 4.5\text{ V}$, $V_{COM} = V_{SUP} = 9\text{ V}$)	100	160		
I_o	Output current	Source ($V_{OPI} = V_{SUP}/2 = 4.5\text{ V}$, $V_{OFFSET} = 15\text{ mV}$)		120		mA
		Sink ($V_{OPI} = V_{SUP}/2 = 4.5\text{ V}$, $V_{OFFSET} = 15\text{ mV}$)		130		
PSRR	Power supply rejection ratio			40		dB
SR	Slew rate	$A_V = 1$, $V_{OPI} = 2\text{ Vpp}$		40		V/ μs
BW	-3db bandwidth	$A_V = 1$, $V_{OPI} = 60\text{ mVpp}$		60		MHz

(2) External pull-up resistor to be chosen so that the current flowing into \overline{XAO} Pin ($V_{\overline{XAO}} = 0\text{ V}$) when active is below $I_{\overline{XAO_MIN}} = 1\text{ mA}$.

(3) Maximum output voltage limited by the Overvoltage Protection and not the maximum power switch rating of the boost converter.

PIN ASSIGNMENT

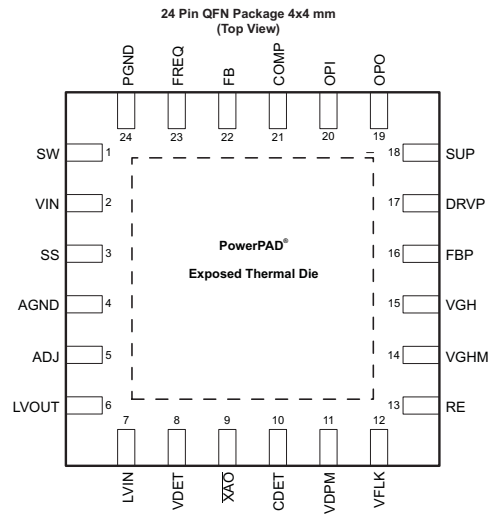

TERMINAL FUNCTIONS

PIN		I/O	DESCRIPTION
NAME	NO.		
SW	1		Switch pin of the boost converter.
VIN	2	I	Input supply pin.
SS	3	I/O	Boost soft-start control pin. Connect a capacitor to this pin if a soft-start is needed. Open = no soft-start.
AGND	4, exposed pad		Analog ground.
ADJ	5	I	LDO feedback pin.
LVOUT	6	O	LDO output pin.
LVIN	7	I	LDO input supply pin.
VDET	8	I	Reset function threshold pin. Connect a voltage divider to this pin to set the threshold voltage.
$\overline{\text{XAO}}$	9	O	Reset function output pin (open-drain). $\overline{\text{XAO}}$ signal is active low.
CDET	10	I/O	Sets the reset delay time. Pin for external capacitor. Floating if no delay is needed.
VDPM	11	I/O	Sets the delay to enable VGHM Output. Pin for external capacitor. Floating if no delay needed.
VFLK	12	I	Input pin for charge/discharge signal for VGHM. VFLK = "high" discharges VGHM through RE pin.
RE	13		Slope adjustment pin for gate voltage shaping. Connect a resistor to this pin to set the discharging slope of VGHM when VFLK = "high".
VGHM	14	O	Gate voltage shaping output pin
VGH	15	I	Input pin for the positive charge pump voltage.
FBP	16	I	Positive charge pump feedback pin.
DRVVP	17	O	Voltage driver pin of the positive charge pump.
SUP	18	I	Input supply pin for the gate voltage shaping and operational amplifier blocks. Also overvoltage protection sense pin. SUP pin must be supplied by V _S voltage.
OPO	19	O	Output pin of the VCOM Buffer.
OPI	20	I	Input pin of the VCOM Buffer.
COMP	21	I/O	Boost converter compensation pin .
FB	22	I	Boost converter feedback pin.
FREQ	23	I	Boost converter frequency select pin. Oscillator is 650 kHz when FREQ is connected to GND and 1.2 MHz when FREQ is connected to VIN.
PGND	24		Power ground.

FUNCTIONAL BLOCK DIAGRAM

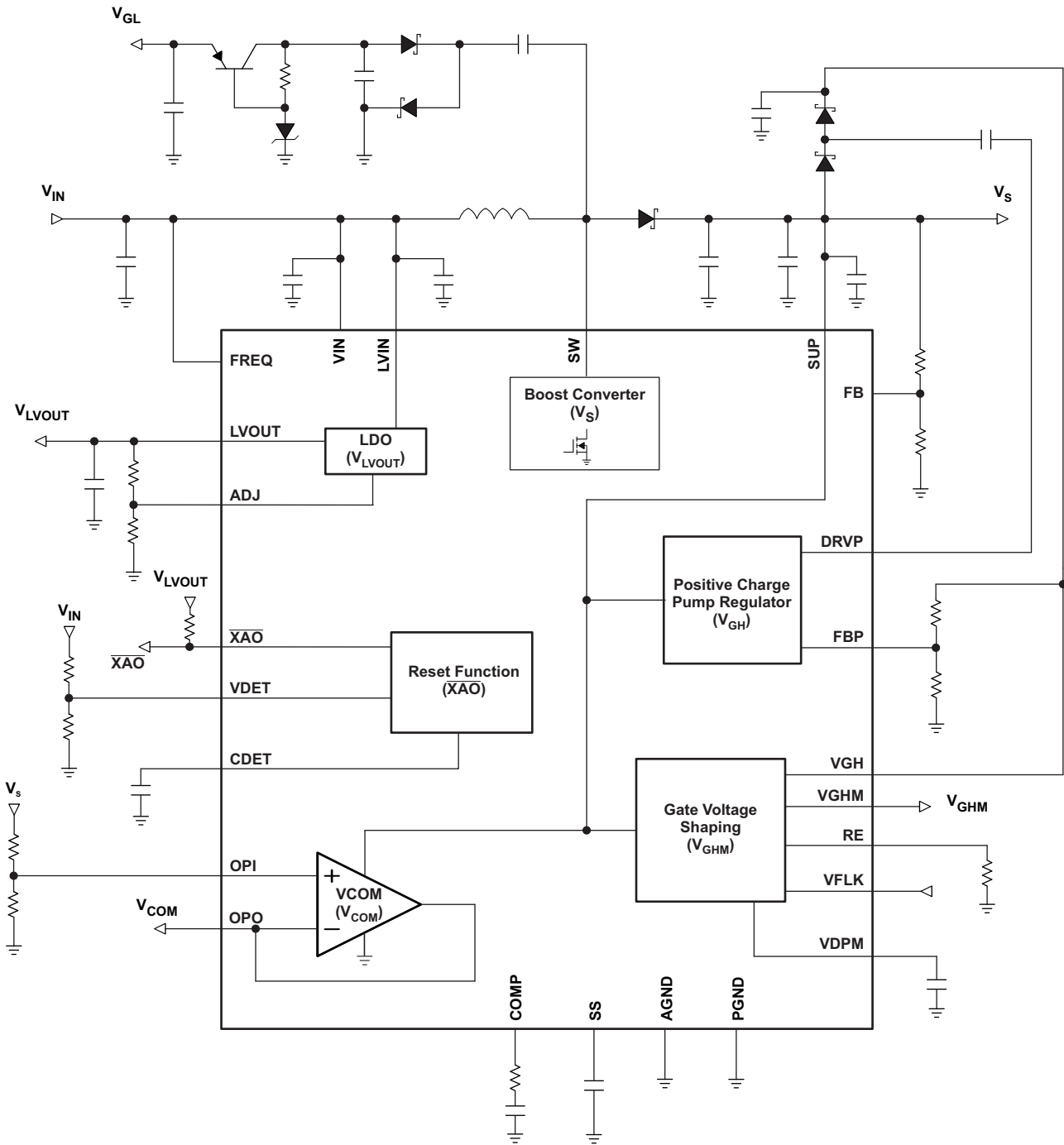

TYPICAL CHARACTERISTICS
TABLE OF GRAPHS

		FIGURE
Efficiency vs Load Current	$V_{IN} = 3.3\text{ V}$, $V_S = 9\text{ V}$ $f = 650\text{ kHz}/1.2\text{ MHz}$	Figure 1
Efficiency vs Load Current	$V_{IN} = 3.3\text{ V}$, $V_S = 12\text{ V}$ $f = 650\text{ kHz}/1.2\text{ MHz}$	Figure 2
PWM Switching Discontinuous Conduction Mode	$V_{IN} = 3.3\text{ V}$, $V_S = 9\text{ V}/4\text{ mA}$ $f = 1.2\text{ MHz}$	Figure 3
PWM Switching Continuous Conduction Mode	$V_{IN} = 3.3\text{ V}$, $V_S = 9\text{ V}/300\text{ mA}$ $f = 1.2\text{ MHz}$	Figure 4
Boost Frequency vs Load Current	$V_{IN} = 3.3\text{ V}$, $V_S = 9\text{ V}$ $f = 650\text{ kHz}/1.2\text{ MHz}$	Figure 5
Boost Frequency vs Supply Voltage	$V_S = 9\text{ V}/150\text{ mA}$, $f = 650\text{ kHz}/1.2\text{ MHz}$	Figure 6
Load Transient Response Boost Converter High Frequency	$V_{IN} = 3.3\text{ V}$, $V_S = 9\text{ V}$ $I_{OUT} = 50\text{ mA} \sim 200\text{ mA}$, $f = 1.2\text{ MHz}$	Figure 7
Load Transient Response Boost Converter Low Frequency	$V_{IN} = 3.3\text{ V}$, $V_S = 9\text{ V}$ $I_{OUT} = 50\text{ mA} \sim 200\text{ mA}$, $f = 650\text{ kHz}$	Figure 8
Soft-start Boost Converter	$V_{IN} = 3.3\text{ V}$, $V_S = 9\text{ V}$, $I_{OUT} = 300\text{ mA}$	Figure 9
Overshoot Protection Boost Converter (OVP)	$V_{IN} = 3.3\text{ V}$, $V_S = 9\text{ V}$	Figure 10
Load Transient Response LDO	$V_{LVIN} = 3.3\text{ V}$, $V_{LVOUT} = 2.5\text{ V}$ $I_{LVOUT} = 100\text{ mA} \sim 300\text{ mA}$	Figure 11
Gate Voltage Shaping	$V_{GH} = 20\text{ V}$	Figure 12
V_{GHM} Voltage vs Load Current	$V_{IN} = 3.3\text{ V}$, $V_S = 9\text{ V}$, $V_{GHM} = 19.8\text{ V}$	Figure 13
V_{GL} Voltage vs Load Current	$V_{IN} = 3.3\text{ V}$, $V_S = 9\text{ V}$, $V_{GL} = -6.7\text{ V}$	Figure 14
Power on Sequencing \overline{XAO} Signal and V_{GHM} Delay	$V_{IN} = 3.3\text{ V}$, $V_S = 9\text{ V}$, $V_{GHM} = 20\text{ V}$	Figure 15
Power off Sequencing \overline{XAO} Signal and V_{GHM} Delay	$V_{IN} = 3.3\text{ V}$, $V_S = 9\text{ V}$, $V_{GHM} = 20\text{ V}$	Figure 16
Power on Sequencing	$V_{IN} = 3.3\text{ V}$, $V_S = 9\text{ V}$, $V_{LVOUT} = 2.5\text{ V}$, $V_{VCOM} = 4.5\text{ V}$, $V_{GHM} = V_{GH} = 20\text{ V}$, $V_{GL} = -7\text{ V}$	Figure 17
Power off Sequencing	$V_{IN} = 3.3\text{ V}$, $V_S = 9\text{ V}$, $V_{LVOUT} = 2.5\text{ V}$, $V_{VCOM} = 4.5\text{ V}$, $V_{GHM} = V_{GH} = 20\text{ V}$, $V_{GL} = -7\text{ V}$	Figure 18

For all the following graphics, the inductors used for the measurements are MSS7341 ($L = 5\text{ }\mu\text{F}$) for $f = 1.2\text{ MHz}$, and CDRH8D28 ($L = 10\text{ }\mu\text{F}$) for $f = 650\text{ kHz}$.

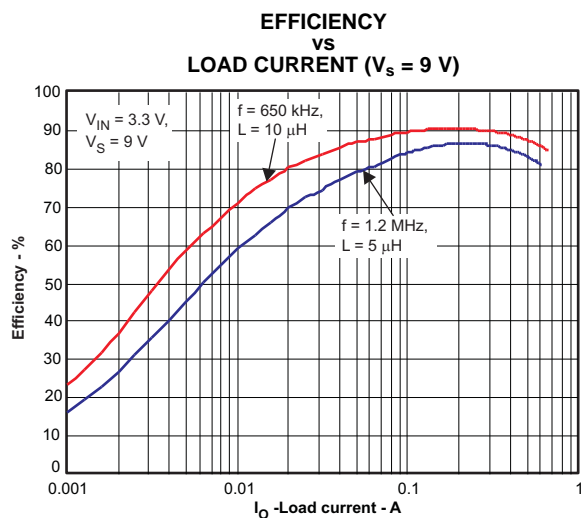
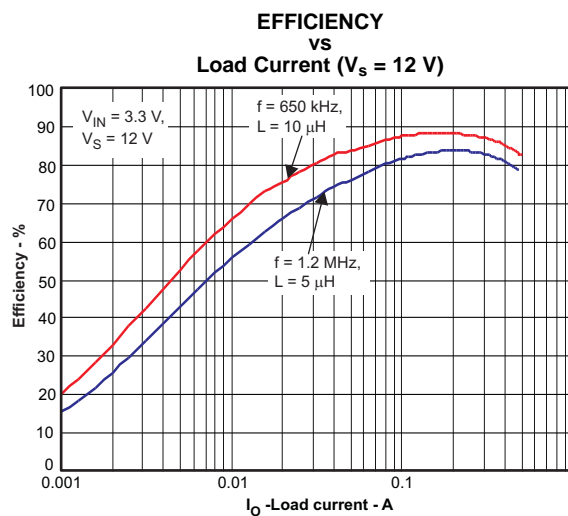
Figure 1.

Figure 2.

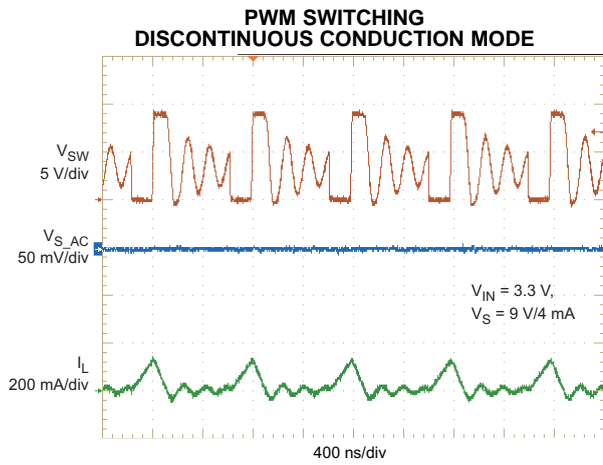

Figure 3.

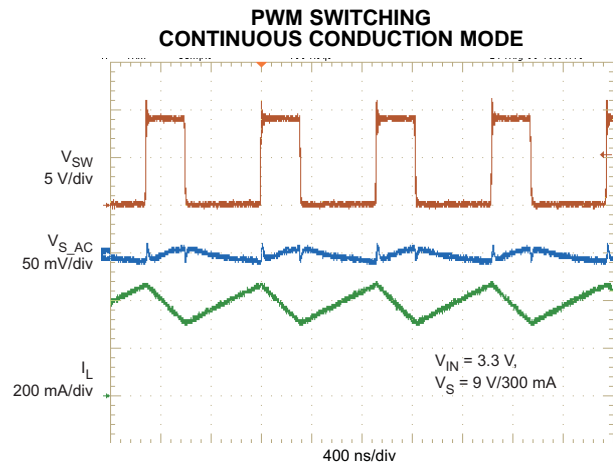

Figure 4.

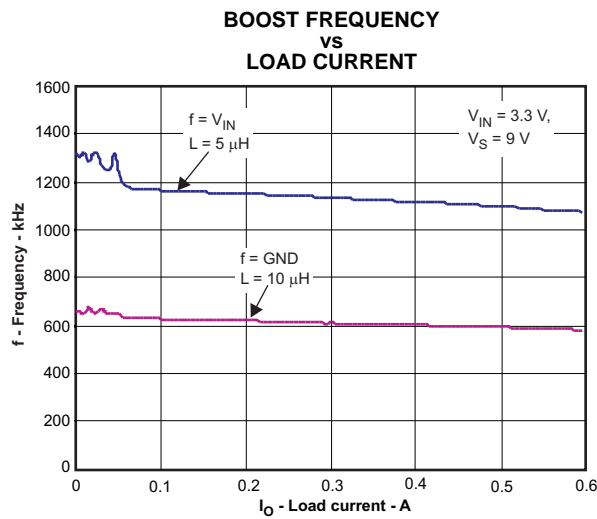

Figure 5.

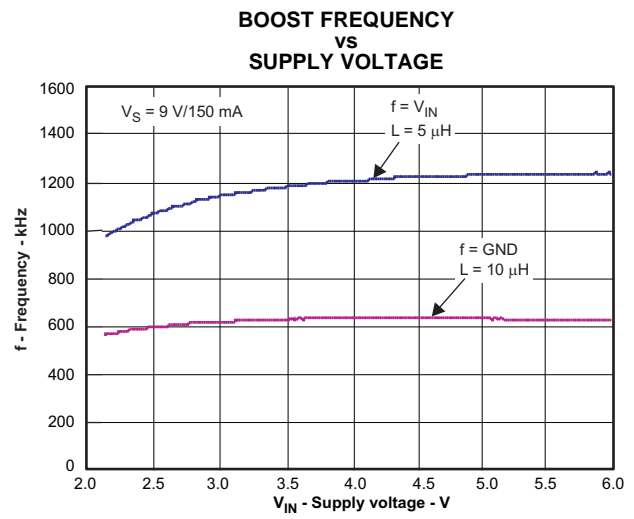

Figure 6.

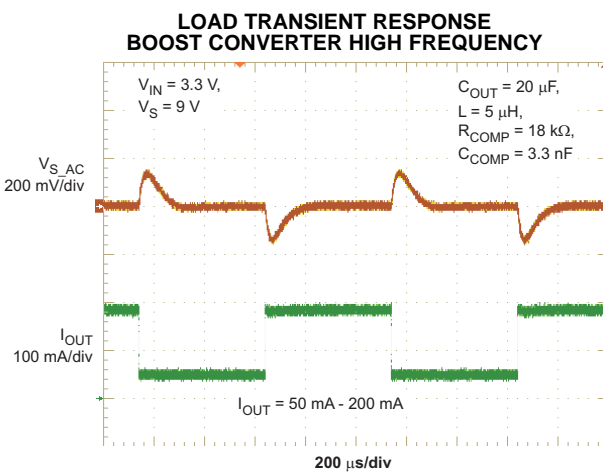

Figure 7.

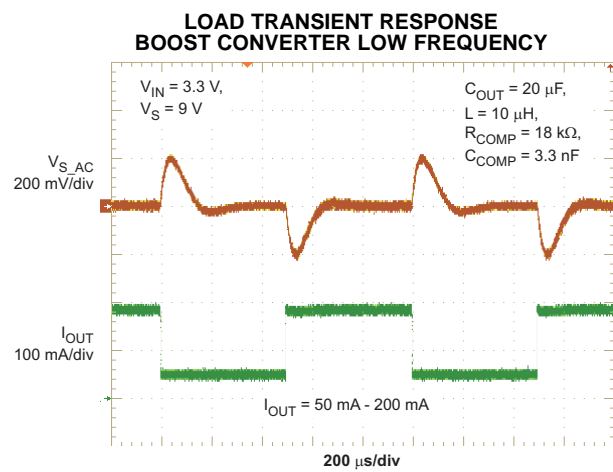
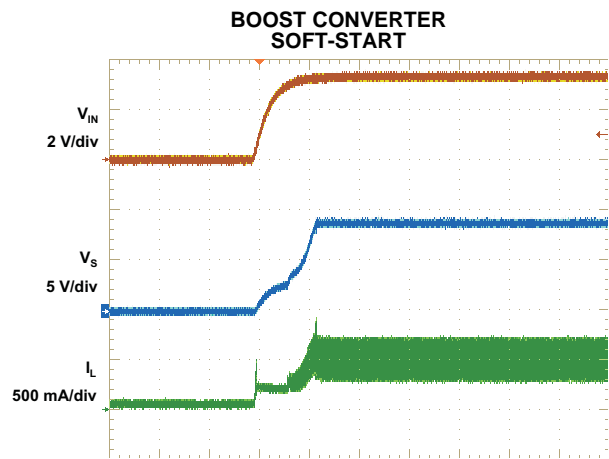
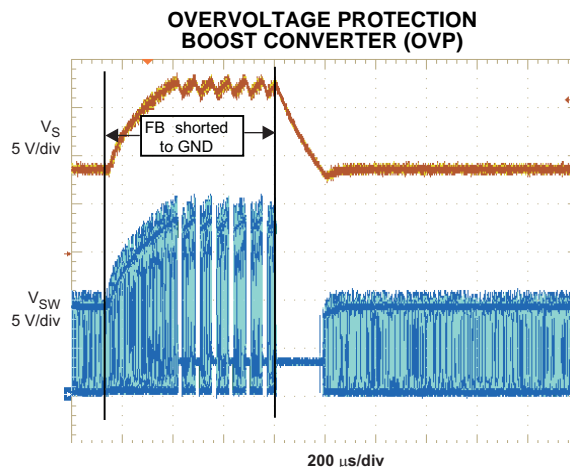

Figure 8.



10 ms/div
Figure 9.



200 μs/div
Figure 10.

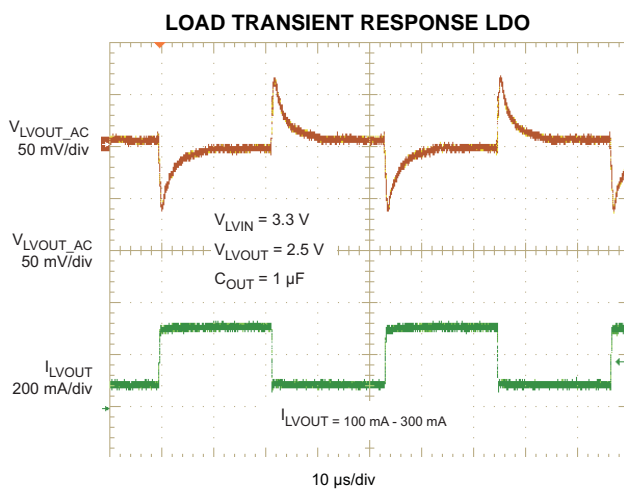

10 μs/div
Figure 11.

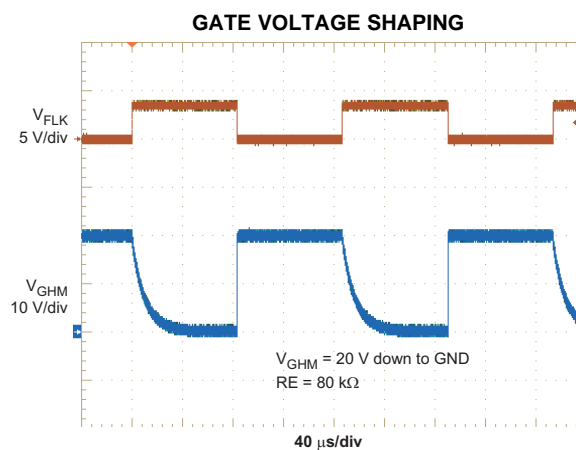

40 μs/div
Figure 12.

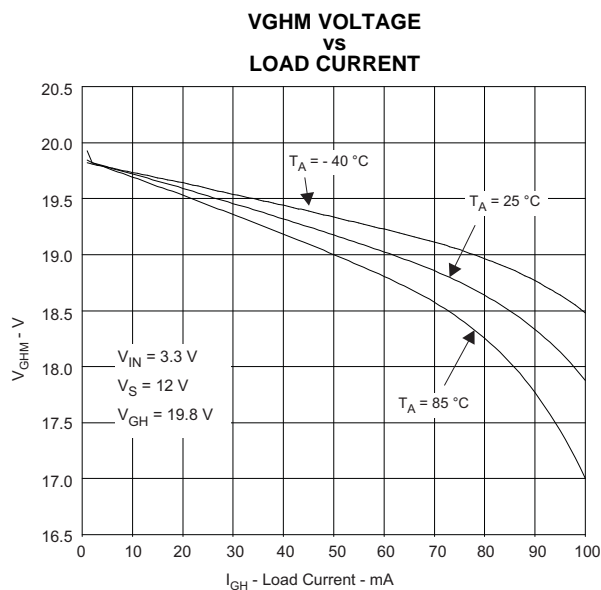

Figure 13.

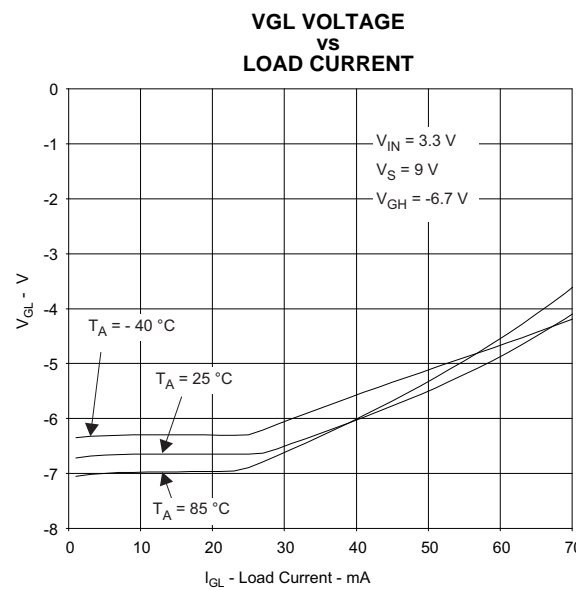

Figure 14.

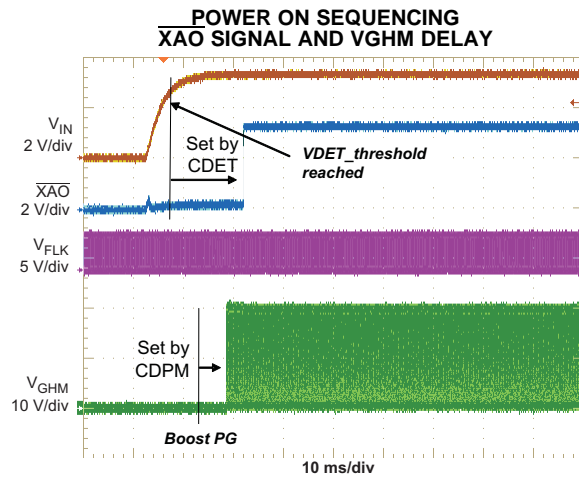

Figure 15.

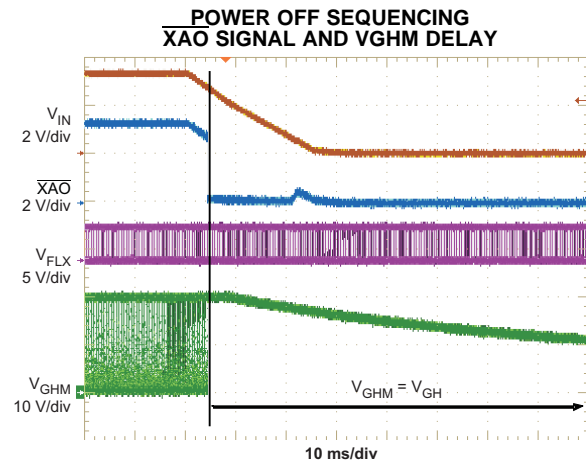

Figure 16.

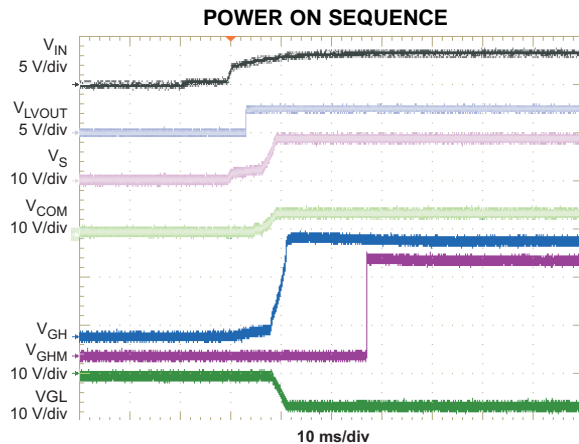

Figure 17.

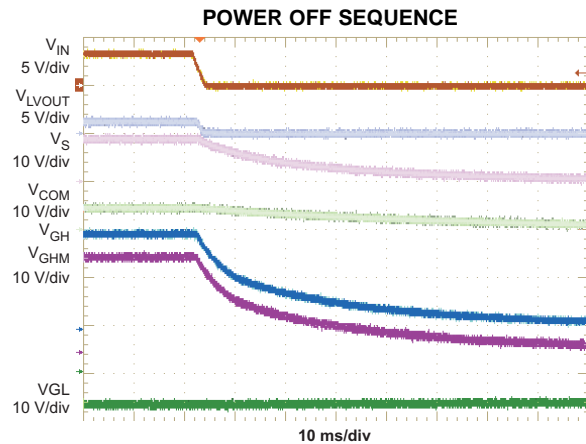

Figure 18.

APPLICATION INFORMATION

BOOST CONVERTER

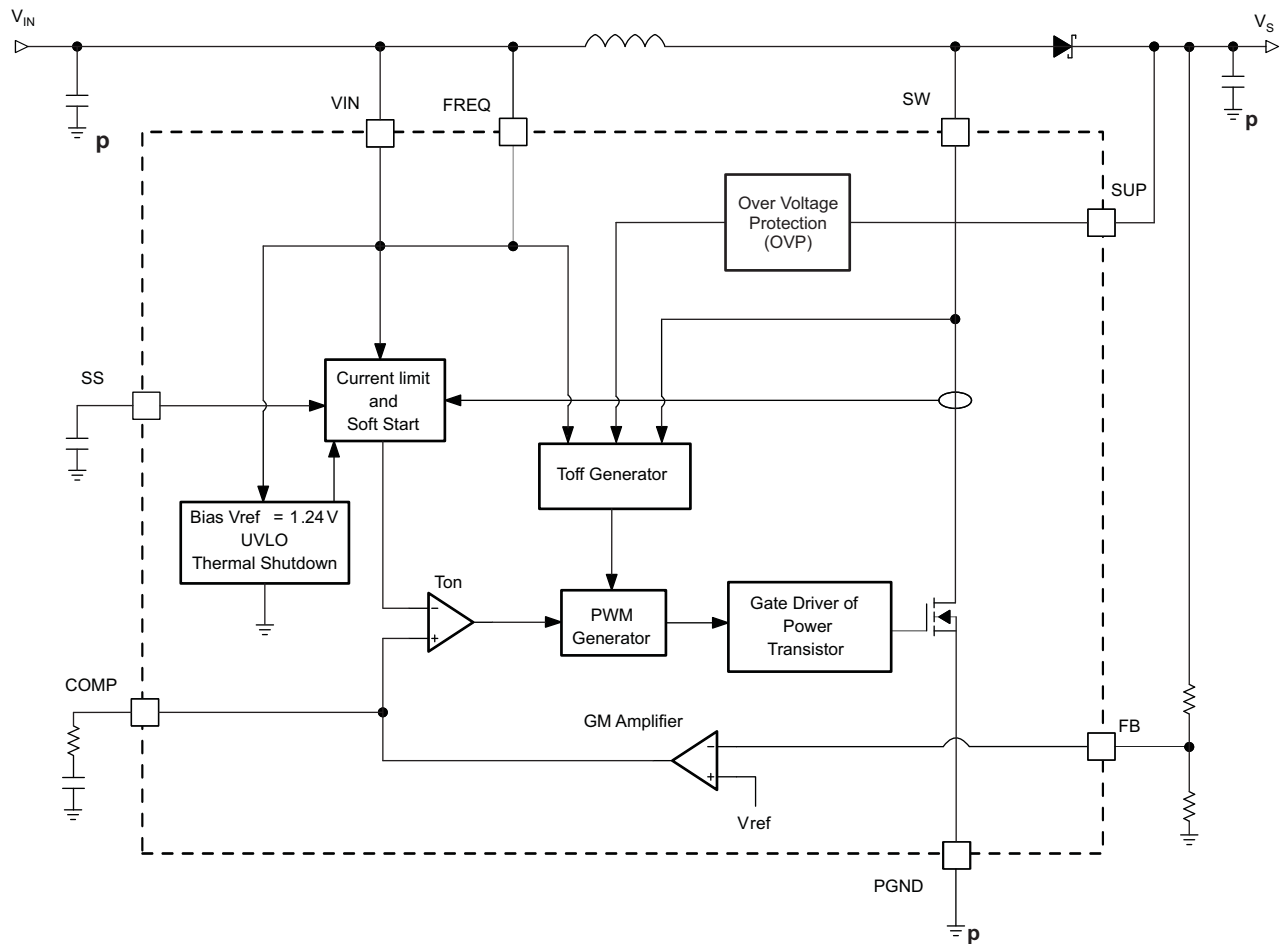

Figure 19. Boost converter block diagram

The boost converter is designed for output voltages up to 16.5 V with a switch peak current limit of 2.0 A minimum. The device, which operates in a current mode scheme with quasi-constant frequency, is externally compensated for maximum flexibility and stability. The switching frequency is selectable between 650 kHz and 1.2 MHz and the minimum input voltage is 2.5 V. To limit the inrush current at start-up a soft-start pin is available.

During the on-time, the current rises into the inductor. When the current reaches a threshold value set by the internal GM amplifier, the power transistor is turned off. The polarity of the inductor changes and forward biases the Schottky diode which lets the current flow towards the output of the boost converter. The off-time is fixed for a certain V_{IN} and V_S , and therefore maintains the same frequency when varying these parameters.

However, for different output loads, the frequency slightly changes due to the voltage drop across the $R_{DS(ON)}$ of the power transistor which will have an effect on the voltage across the inductor and thus on t_{ON} (t_{OFF} remains fixed).

The fixed off-time maintains a quasi-fixed frequency that provides better stability for the system over a wide range of input and output voltages than conventional boost converters. The TPS65146 topology has also the benefits of providing very good load and line regulations, and excellent line and load transient responses.

Boost Converter Design Procedure

The first step in the design procedure is to verify whether the maximum possible output current of the boost converter supports the specific application requirements. A simple approach is to estimate the converter efficiency, by taking the efficiency numbers from the provided efficiency curves or to use a worst case assumption for the expected efficiency, e.g. 85%.

1. Duty Cycle: $D = \frac{V_{IN} \times \eta}{V_S}$
2. Inductor ripple current: $\Delta I_L = \frac{V_{IN} \times D}{f \times L}$
3. Maximum output current: $I_{OUT_max} = \left(I_{LIM_min} - \frac{\Delta I_L}{2} \right) \times (1 - D)$
4. Peak switch Current: $I_{swpeak} = \frac{\Delta I_L}{2} + \frac{I_{out}}{1 - D}$

I_{swpeak} = converter switch current (must be < $I_{LIM_min} = 2.0$ A)

f_S = Converter switching frequency (typically 1.2 MHz or 650 kHz)

L = Selected inductor value (see the Inductor Selection section)

η = Estimated converter efficiency (please use the number from the efficiency plots or 85% as an estimation)

ΔI_L = Inductor peak-to-peak ripple current

The peak switch current is the steady state peak switch current the integrated switch, inductor and external Schottky diode has to be able to handle. The calculation must be done for the minimum input voltage where the peak switch current is highest.

Soft-Start (Boost Converter)

The boost converter has an adjustable soft-start to prevent high inrush current during start-up. To minimize the inrush current during start-up an external capacitor connected to the soft-start pin SS is used to slowly ramp up the internal current limit of the boost converter. When the V_{IN} exceeds the Undervoltage Lockout (UVLO) threshold, the soft-start capacitor C_{SS} is immediately charged up to 0.3 V. The capacitor is then charged at a constant current of 4 μ A typically until the output of the boost converter V_S has reached its Power Good threshold (90% of V_S nominal value). During this time, the voltage on SS pin directly controls the peak inductor current, starting with 0 A at $V_{SS} = 0.3$ V up to the full current limit at $V_{SS} \approx 800$ mV. The maximum load current is available after the soft-start is completed. The larger the capacitor, the slower the ramp of the current limit and the longer the soft-start time. A 100 nF capacitor is usually sufficient for most of the applications. When V_{IN} falls down below the UVLO level, the soft-start capacitor is discharged to ground.

Frequency Select Pin (FREQ)

The digital frequency select pin FREQ allows to set the switching frequency of the device to 650 kHz (FREQ = low) or 1.2 MHz (FREQ = high). Higher switching frequency improves load transient response but reduces slightly the efficiency. The other benefits of higher switching frequency are a lower output voltage ripple. Usually, it is recommended to use 1.2 MHz switching frequency unless light load efficiency is a major concern.

Inductor Selection

The main parameter for the inductor selection is the saturation current of the inductor which should be higher than the peak switch current as calculated above with additional margin to cover for heavy load transients. An alternative, more conservative, is to choose the inductor with a saturation current at least as high as the maximum switch current limit of 3.0 A. Another important parameter is the inductor DC resistance. Usually the lower the DC resistance the higher the efficiency. It is important to note that the inductor DC resistance is not the only parameter determining the efficiency. Especially for a boost converter where the inductor is the energy storage element, the type and core material of the inductor influences the efficiency as well. At high switching

frequencies of 1.2 MHz inductor core losses, proximity effects and skin effects become more important. Usually an inductor with a larger form factor gives higher efficiency. The efficiency difference between different inductors can vary between 2% to 10%. For the TPS65146, inductor values between 3.3 μH and 6.8 μH are a good choice with a switching frequency of 1.2 MHz. At 650 kHz we recommend inductors between 7 μH and 13 μH . I_{sat} $\geq I_{\text{swpeak}}$ imperatively. Possible inductors are shown in [Table 1](#).

Table 1. Inductor Selection

L (μH)	COMPONENT SUPPLIER	COMPONENT CODE	SIZE (LxWxH mm)	DCR TYP (m Ω)	I_{sat} (A)
1.2 MHz					
4.7	Sumida	CDRH3D14	4 × 4 × 1.5	120	1.1
4.7	Coilcraft	LPS4414-472ML	4.3 × 4.3 × 1.4	215	1.5
4.2	Sumida	CDRH5D28	5.7 × 5.7 × 3	23	2.2
5.0	Coilcraft	MSS7341	7.3 × 7.3 × 4.1	24	2.9
650 kHz					
10	Sumida	CDC5D23B	6 × 6 × 2.5	102	1.04
10	Sumida	CDR6D23MNNP	5 × 5 × 2.4	83	1.75
10	Würth Elektronik	744778910	7.3 × 7.3 × 3.2	51	2.2
10	Sumida	CDRH8D28	8.3 × 8.3 × 3	36	2.5

Rectifier Diode Selection

To achieve high efficiency a Schottky type should be used for the rectifier diode. The reverse voltage rating should be higher than the maximum output voltage of the converter. The averaged rectified forward current I_{avg} , the Schottky diode needs to be rated for, is equal to the output current I_{OUT} :

$$I_F = I_{\text{OUT}} \quad (1)$$

Usually a Schottky diode with 1 A to 1.5 A maximum average rectified forward current rating is sufficient for most of the applications. Also, the Schottky rectifier has to be able to dissipate the power. The dissipated power is the average rectified forward current I_F times the diode forward voltage V_F (or V_{Diode}).

$$P_D = I_F \times V_F$$

Typically the diode should be able to dissipate around 500mW depending on the load current and forward voltage.

Table 2. Rectifier Diode Selection

CURRENT RATING I_F	V_R	V_F / I_F	COMPONENT SUPPLIER	COMPONENT CODE	PACKAGE TYPE
750 mA	20 V	0.425 V/750 mA	Fairchild Semiconductor	FYV0704S	SOT 23
1 A	20 V	0.39 V/1 A	NXP	PMEG2010AEH	SOD 123
1 A	20 V	0.5 V/1 A	Vishay	SS12	SMA
1 A	20 V	0.44 V/1 A	Vishay	MSS1P2L	μ -SMP (<i>Low Profile</i>)
1.5 A	25 V	0.5 V/1 A	Vishay	BYS10-25	SMA

Setting the Output Voltage

The output voltage is set by an external resistor divider. Typically, a minimum current of 50 μA flowing through the feedback divider is enough to cover the noise fluctuation. The resistors are then calculated with 70 μA as:

$$R2 = \frac{V_{FB}}{70 \mu\text{A}} \approx 18 \text{ k}\Omega \quad R1 = R2 \times \left(\frac{V_S}{V_{FB}} - 1 \right)$$

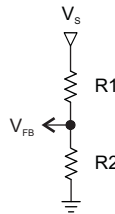

(2)

 with $V_{FB} = 1.240 \text{ V}$

Compensation (COMP)

The regulation loop can be compensated by adjusting the external components connected to the COMP pin. The COMP pin is the output of the internal transconductance error amplifier. The compensation capacitor will adjust the low frequency gain and the resistor value will adjust the high frequency gain. Lower output voltages require a higher gain and therefore a lower compensation capacitor value. A good start, that will work for the majority of the applications is $C_{COMP} = 3.3 \text{ nF}$ and $R_{COMP} = 18 \text{ k}\Omega$ for a 3.3 V input.

Input Capacitor Selection

For good input voltage filtering low ESR ceramic capacitors are recommended. TPS65146 has an analog input VIN. A 1- μF bypass is required as close as possible from VIN to GND.

One 10- μF ceramic input capacitor is sufficient for most of the applications. For better input voltage filtering this value can be increased. Refer to [Table 3](#) and typical applications for input capacitor recommendations.

Output Capacitor Selection

For best output voltage filtering a low ESR output capacitor is recommended. Two 10- μF ceramic output capacitors work for most of the applications. Higher capacitor values can be used to improve the load transient response. Refer to [Table 3](#) for the selection of the output capacitor.

Table 3. Rectifier Input and Output Capacitor Selection

CAPACITOR	VOLTAGE RATING	COMPONENT SUPPLIER	COMPONENT CODE	COMMENTS
10 $\mu\text{F}/0805$	10 V	Taiyo Yuden	LMK212 BJ 106KD	C_{IN}
1 $\mu\text{F}/0603$	10 V	Taiyo Yuden	EMK107 BJ 105KA	VIN bypass
10 $\mu\text{F}/1206$	25 V	Taiyo Yuden	TMK316 BJ 106ML	C_{OUT}

To calculate the output voltage ripple that following equations can be used:

$$\Delta V_C = \frac{V_S - V_{IN}}{V_S \times f} \times \frac{I_{OUT}}{C} \quad \Delta V_{C_ESR} = \Delta I_L \times R_{C_ESR} \quad (3)$$

ΔV_{C_ESR} can be neglected in many cases since ceramic capacitors provide very low ESR.

Undervoltage Lockout (UVLO)

To avoid mis-operation of the device at low input voltages an undervoltage lockout is included that disables the device, if the input voltage falls below 2.0 V.

Thermal shutdown

A thermal shutdown is implemented to prevent damages because of excessive heat and power dissipation. Typically the thermal shutdown threshold for the junction temperature is 150°C. When the thermal shutdown is triggered the device stops switching until the junction temperature falls below typically 136 °C. Then the device starts switching again.

Overvoltage Protection

The boost converter has an integrated overvoltage protection to prevent the power switch from exceeding the absolute maximum switch voltage rating at pin SW in case the feedback (FB) pin is floating or shorted to GND. In such an event, the output voltage rises and is monitored with the overvoltage protection comparator over the SUP pin. As soon as the comparator trips at typically 18 V, the boost converter turns the N-Channel MOSFET switch off. The output voltage falls below the overvoltage threshold and the converter continues to operate. In order to detect overvoltage, the SUP pin needs to be connected to the output voltage of the boost converter V_S .

LOW DROPOUT LINEAR REGULATOR (LDO)

The TPS65146 includes a Low Dropout Regulator providing the logic voltage to the panel. The LDO is designed to operate typically with a 1- μ F ceramic output capacitor. The LDO has an internal softstart feature to limit the inrush current. A minimum current of 50 μ A flowing through the feedback divider is usually enough to cover the noise fluctuation. The resistors of the voltage divider are then calculated with 70 μ A as:

$$R4 = \frac{V_{ADJ}}{70 \mu A} \approx 18 \text{ k}\Omega$$

$$R3 = R4 \times \left(\frac{V_{LVOUT}}{V_{ADJ}} - 1 \right)$$

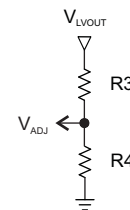

(4)

with $V_{ADJ} = 1.240 \text{ V}$

REGULATED POSITIVE CHARGE PUMP

The positive charge pump sets the voltage applied on the V_{GH} input pin, up to 32 V in tripler mode configuration. The charge pump block regulates the V_{GH} voltage by adjusting the drive current I_{DRVP}. Typically, a minimum current of 50 μA flowing through the feedback divider is usually enough to cover the noise fluctuation. The resistors of the divider used to set the V_{GH} voltage are calculated as:

$$R11 = \frac{V_{FBP}}{70 \mu A} \approx 18 \text{ k}\Omega$$

$$R10 = R11 \times \left(\frac{V_{GH}}{V_{FBP}} - 1 \right)$$

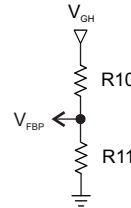

(5)

with V_{FBP} = 1.240 V

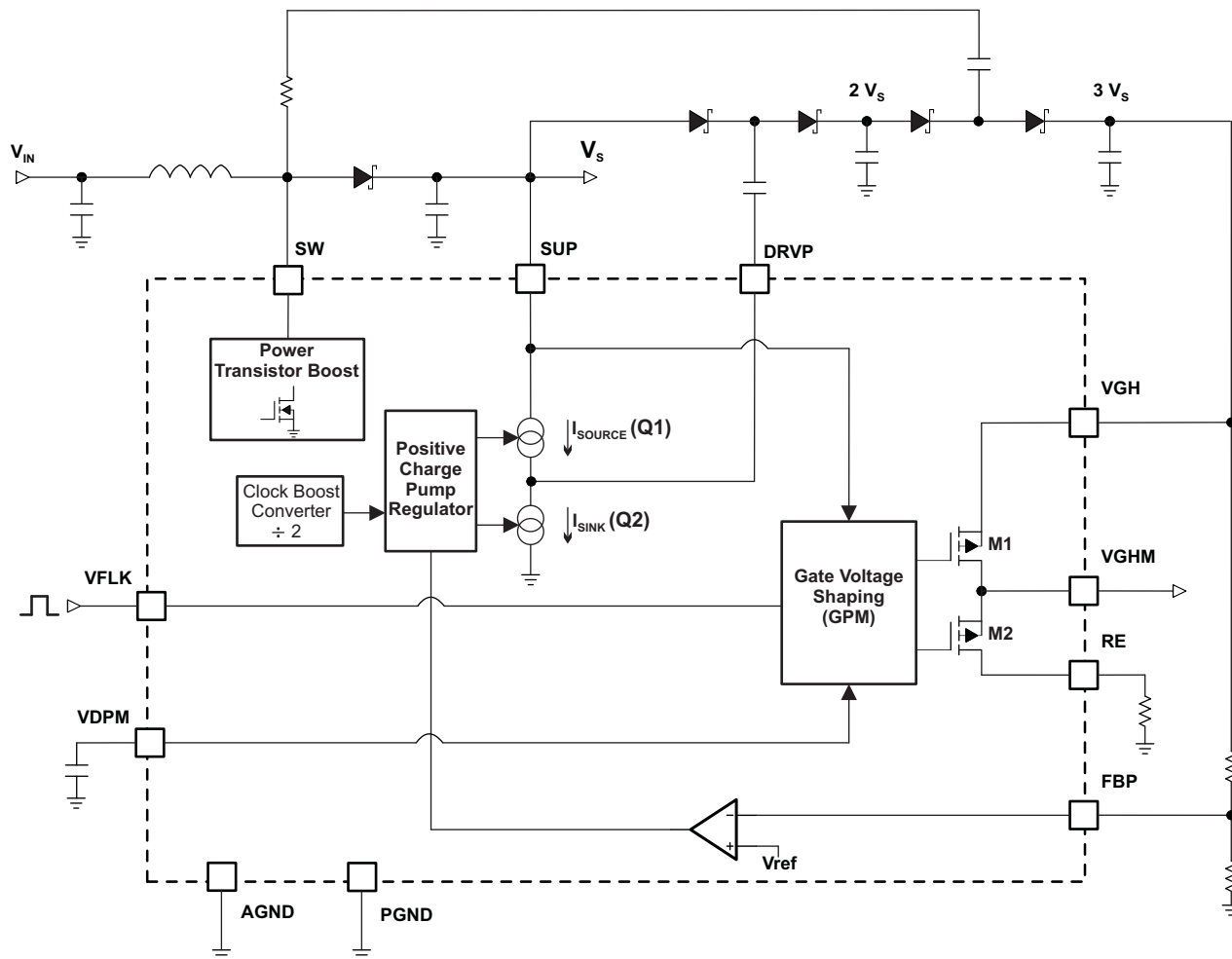

Figure 20. Positive Charge Pump regulator and Gate Voltage Shaping blocks

Doubler Mode: to use the positive Charge Pump in doubler mode configuration, the Schottky diode connected between the capacitor of DRVP pin and the 2.V_S point has to be connected to the 3.V_S point (see [Figure 20](#)).

Tripler Mode: since V_{GH} pin is rated to maximum 32 V, the maximum output voltage of the boost converter (V_S) possible is then limited to 11 V.

POSTIVE CHARGE PUMP CURRENT CAPABILITY

The possible output current that the positive charge pump is able to deliver in doubler mode depends mainly on the headroom ($2 \cdot V_S - V_{GH}$) and the internal voltage drop $V_{drop_internal}$. The graph below (Figure 21) helps defining the headroom range that the system needs:

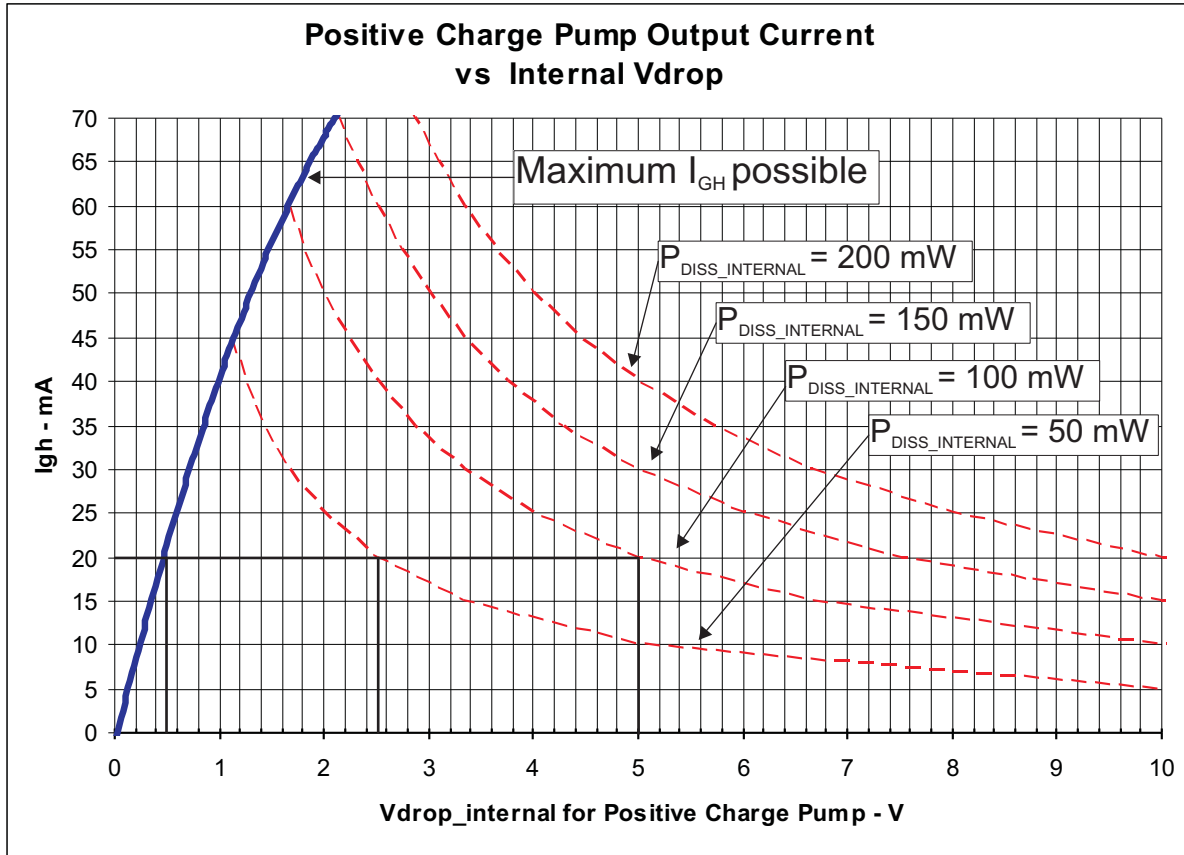

Figure 21.

Example:

For $I_{GH} = 20 \text{ mA}$, we refer to the “maximum I_{GH} possible” curve to determine the minimum headroom needed.

$$V_{headroom_20mA} = 2 \cdot V_{SUP} - V_{GH} \geq V_{drop_int_20mA} + 2 \cdot V_{Diode}^* = 0.5 + 2V = 2.5V \tag{6}$$

* in the case where $V_{Diode} = 1 \text{ V}$

This means that the headroom in this example must be more than 2.5 V to be able to source 20 mA at the output of the positive charge pump.

However, generating a too large headroom can lead to excessive power dissipation. The dashed curves show the internal power dissipation generated by a certain internal voltage drop. In the above example, if $V_{headroom_20mA} = 7 \text{ V}$ (with $V_{Diode} = 1 \text{ V}$), $V_{drop_internal_min} = 5 \text{ V}$ and the internal power dissipation $P_{DISS_INTERNAL}$ for the positive charge pump would reach 100 mW. The power dissipation of the charge pump block needs to be taken into account for the overall power dissipation rating.

NOTE:

refer to the power rating table not to exceed the overall maximum package power dissipation allowed.

EXTERNAL NEGATIVE CHARGE PUMP

The external negative charge pump works with two stages (charge pump and regulation). The charge pump provides a negative regulated output voltage. Figure 22 shows the operation details of the negative charge pump. With the first stage, the voltage on the collector of the bipolar transistor is equal to $-V_S + V_D$.

The next stage regulates the output voltage V_{GL} . A resistor and a Zener diode are used to clamp the voltage to the desired output value. The bipolar transistor is used to provide better load regulation as well as to reduce the quiescent current. The output voltage on V_{GL} will be equal to $-V_Z - V_{be}$.

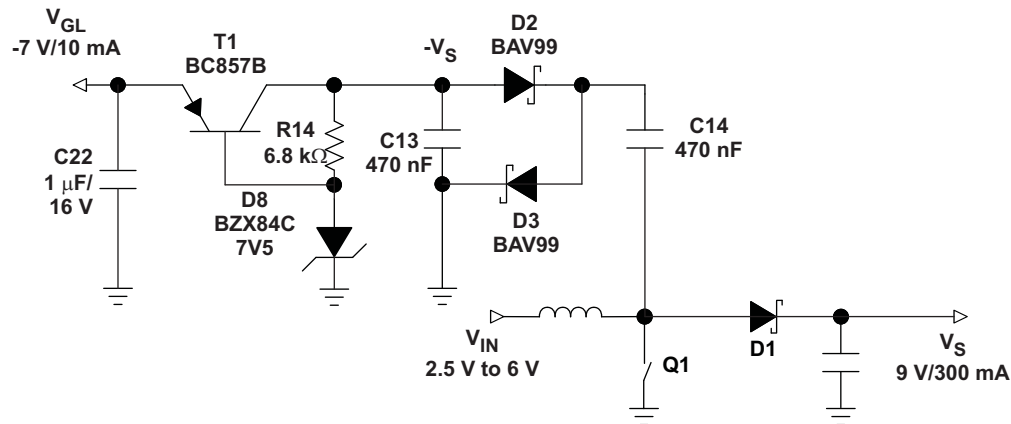

Figure 22. Partially Regulated External Negative

Capacitors (Charge Pumps)

For best output voltage filtering a low ESR output capacitor is recommended. Ceramic capacitors have a low ESR value but depending on the application tantalum capacitors can be used as well. For every capacitor, the reactance value has to be calculated as follows:

$$X_C = \frac{1}{2 \times \pi \times f \times C} \quad (7)$$

This value should be as low as possible in order to reduce the voltage drop due to the current flowing through it. The rated voltage of the capacitor has to be able to withstand the voltage across it. Capacitors rated at 50 V are enough for most of the applications. Typically a 470-nF capacitance is sufficient for the flying capacitors whereas bigger values like 1 μF or more can be used for the output capacitors to reduce the output voltage ripple.

CAPACITOR	COMPONENT SUPPLIER	COMPONENT CODE	COMMENTS
100 nF/0603	Taiyo Yuden	UMK107 BJ 104KA	Flying Cap
470 nF/0805	Taiyo Yuden	UMK212 BJ 474KG	Output Cap 1
1 μF/1210	Taiyo Yuden	UMK325 BJ 105KH	Output Cap 2

Diodes (Charge Pumps)

For high efficiency, one has to minimize the forward voltage drop of the diodes. Schottky diodes are recommended. The reverse voltage rating must withstand the maximum output voltage V_S of the boost converter. Usually a Schottky diode with 200 mA average forward rectified current is suitable for most of the applications.

CURRENT RATING I_{avg}	V_r	$V_{forward} / I_{avg}$	COMPONENT SUPPLIER	COMPONENT CODE	PACKAGE TYPE
200 mA	30 V	0.5V / 30mA	International Rectifier	BAT54S	SOT 23

GATE VOLTAGE SHAPING FUNCTION

Sequencing

At start-up, the VGHM output is enabled once VDPM voltage is higher than $V_{ref} = 1.240$ V. The capacitor connected to VDPM pin sets a delay from the Power Good signal of the boost converter.

$$C_{VDPM} = \frac{I_{DPM} \times t_{DPM}}{V_{ref}} = \frac{20 \mu A \times t_{DPM}}{1.240 V} \quad (8)$$

At power off, VGHM is connected to VGH as soon as VIN reaches the threshold voltage of the reset function.

Setting the Discharge Slope for Gate Voltage Shaping

VFLK = 'high' → VGHM discharges to 0V

VFLK = 'low' → VGHM = VGH

The slope at which VGHM discharges is set by the external resistor connected to RE, the internal MOSFET RDS(ON) (typ. 13Ω for M2 – see block diagram below) and by the external gate line capacitance connected to VGHM pin.

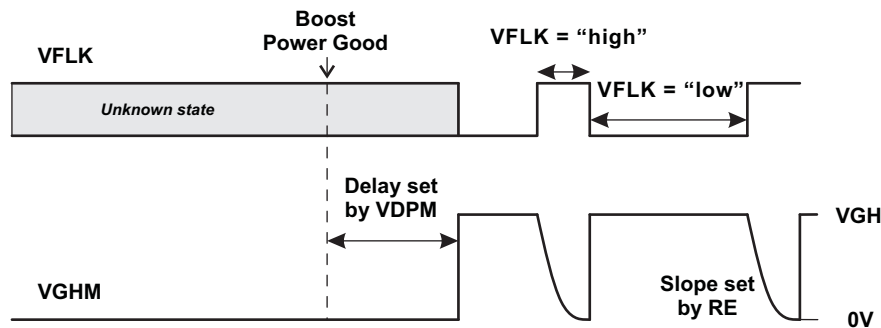

Figure 23. Gate Voltage Shaping Timing

If VFLK = 'high' and RE is connected with a resistor to ground (see Figure 23), VGHM will discharge from VGH to 0V. Since $5 \times \tau$ ($\tau = R \times C$) are needed to fully discharge C through R, we can define the time-constant of the gate voltage shaping block as follow:

$$\tau = (Re + R_{DS(ON)M2}) \times C_{VGHM}$$

Therefore, if the discharge of C_{VGHM} should finish during V_{FLK} = 'high':

$$t_{discharge} = 5 \times \tau = t_{V_{FLK} = 'high'} \Rightarrow RE = \frac{t_{V_{FLK} = 'high'}}{5 \times C_{VGHM}} - R_{DS(ON)M2} \quad (9)$$

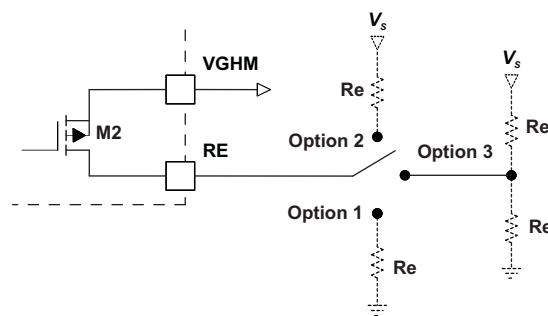

Figure 24. Discharge Path Options for VGHM

Options 2 and 3 from Figure 24 work like option 1 explained above. When M2 is turned on, VGHM discharges with a slope set by Re from VGH level down to Vs in option 2 configuration and in option 3 configuration down to the voltage set by the resistor divider. The discharging slope is set by Re resistor(s).

NOTE:

when options 2 or 3 are used, VGHM is not held to 0V at startup but to the voltage set on RE pin by the resistors Re and Re'.

VCOM BUFFER

The VCOM Buffer power supply pin is the SUP pin connected to the boost converter V_S . To achieve good performance and minimize the output noise, a 1- μF ceramic bypass capacitor is required directly from the SUP pin to ground. The buffer is not designed to drive high capacitive loads; therefore it is recommended to connect a series resistor at the output to provide stable operation when driving high capacitive load. With a 3.3- Ω series resistor, a capacitive load of 10 nF can be driven, which is usually sufficient for typical LCD applications.

RESET FUNCTION

The device has an integrated reset function with an open drain output capable of sinking 1 mA. The reset function monitors the voltage applied to its sense input VDET. As soon as the voltage on VDET falls below the threshold voltage (V_{DET}) of typically 1.1 V, the reset function asserts its reset signal by pulling $\overline{\text{XAO}}$ low. Typically, a minimum current of 50 μA flowing through the feedback divider is enough to cover the noise fluctuation. Therefore, to select R6, one has to set the input voltage limit ($V_{\text{IN_LIM}}$) at which the reset function will pull $\overline{\text{XAO}}$ to low state. $V_{\text{IN_LIM}}$ must be higher than the UVLO threshold.

$$R7 = \frac{V_{\text{DET}}}{70 \mu\text{A}} \approx 18 \text{ k}\Omega$$

$$R6 = R7 \times \left(\frac{V_{\text{IN_LIM}}}{1.1 \text{ V}} - 1 \right)$$

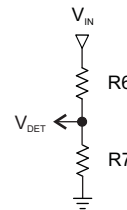

(10)

 with $V_{\text{DET}} = 1.1 \text{ V}$

When the input voltage V_{IN} rises, once the voltage on VDET pin exceeds its threshold voltage plus hysteresis the $\overline{\text{XAO}}$ signal will go high after the delay time set by the capacitor connected to CDET.

$$C_{\text{DET}} = \frac{10 \mu\text{A} \times t_{\text{DET}}}{1.240 \text{ V}}$$

(11)

The reset function is operational for $V_{\text{IN}} \geq 1.6 \text{ V}$.

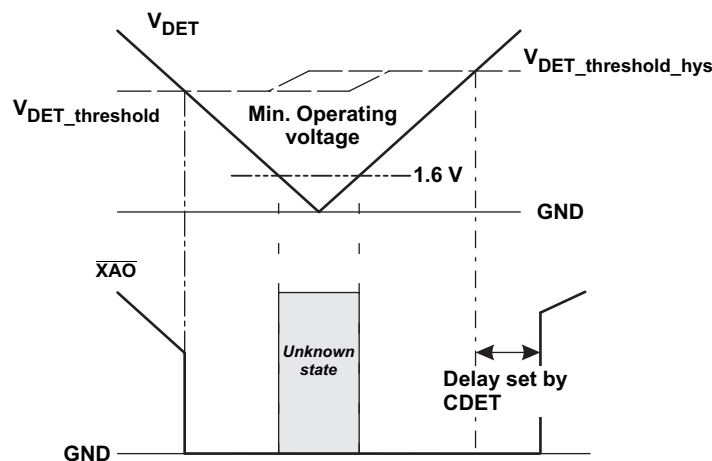

Figure 25. Voltage Detection and $\overline{\text{XAO}}$ Pin

The reset function is configured as a standard open-drain and requires a pull-up resistor. The resistor $R_{\overline{\text{XAO}}}$ (R5) which must be connected between the $\overline{\text{XAO}}$ pin and a positive voltage V_X greater than 2V - 'high' logic level - e.g. V_{LVOUT} , can be chosen as follows:

$$R_{\overline{\text{XAO_min}}} > \frac{V_X}{1 \text{ mA}} \quad \& \quad R_{\overline{\text{XAO_max}}} < \frac{V_X - 2 \text{ V}}{2 \mu\text{A}}$$

(12)

Power on sequencing

Once the input voltage V_{IN} reaches the Under Voltage Lockout (UVLO), the device is internally enabled and the LDO starts rising. When V_{LVOUT} of the LDO is at its Power Good voltage, the boost converter, as well as the Vcom buffer are enabled. As soon as V_S of the boost converter reaches its Power Good (90% of its nominal value), the positive charge pump block is enabled. Then the capacitor connected to VDPM is charged, setting the gate voltage shaping block delay time, and finally enables the VGHM signal.

1. LDO
2. Boost converter & VCOM Buffer
3. VGH and VDPM (delay time to enable the gate voltage shaping function)
4. VGHM (after proper delay)

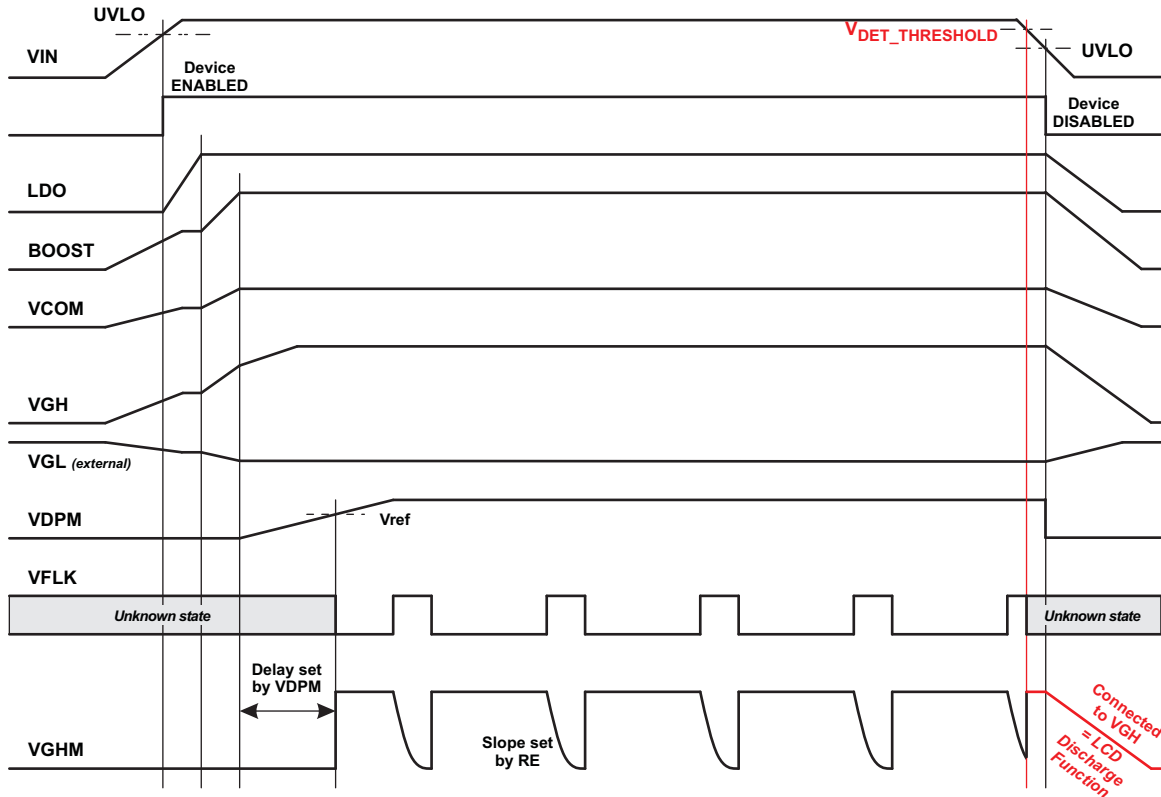

Figure 26. Sequencing TPS65146

Power off sequencing and LCD discharge function

When the input voltage V_{IN} falls below a predefined threshold (set by $V_{DET_THRESHOLD}$ - see Figure 26), \overline{XAO} is driven low and V_{GHM} is driven to V_{GH} . (Note that when V_{IN} falls below the UVLO threshold, all IC functions are disabled except \overline{XAO} and V_{GHM}). Since V_{GHM} is connected to V_{GH} , it tracks the output of the positive charge pump as it decays. This feature, together with \overline{XAO} can be used to discharge the panel by turning on all the pixel TFTs and discharging them into the gradually decaying V_{GHM} voltage. V_{GHM} is held low during power-up.

APPLICATION INFORMATION

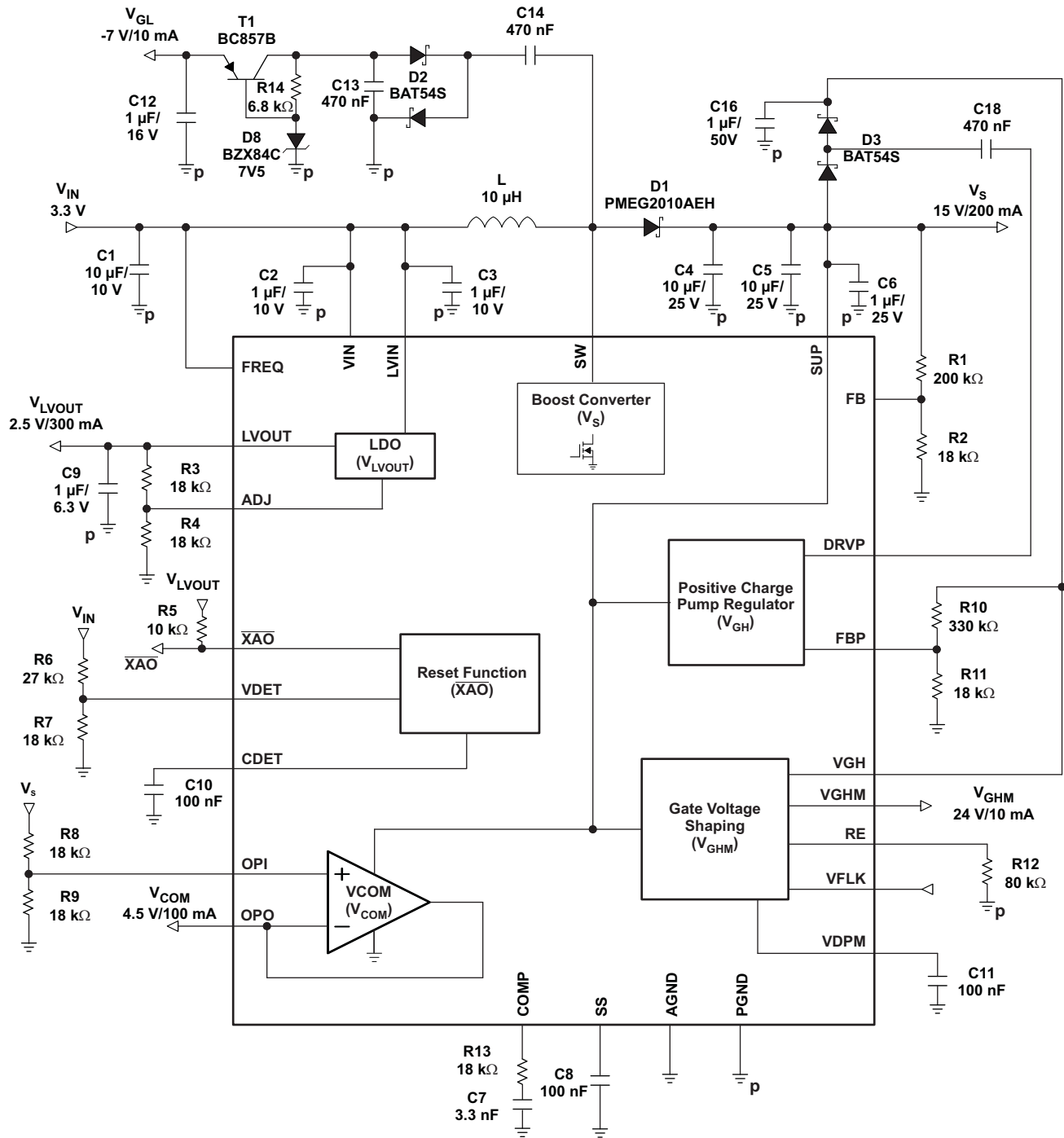

Figure 27. TPS65146 Typical Application with Positive Charge Pump in Doubler Mode Configuration

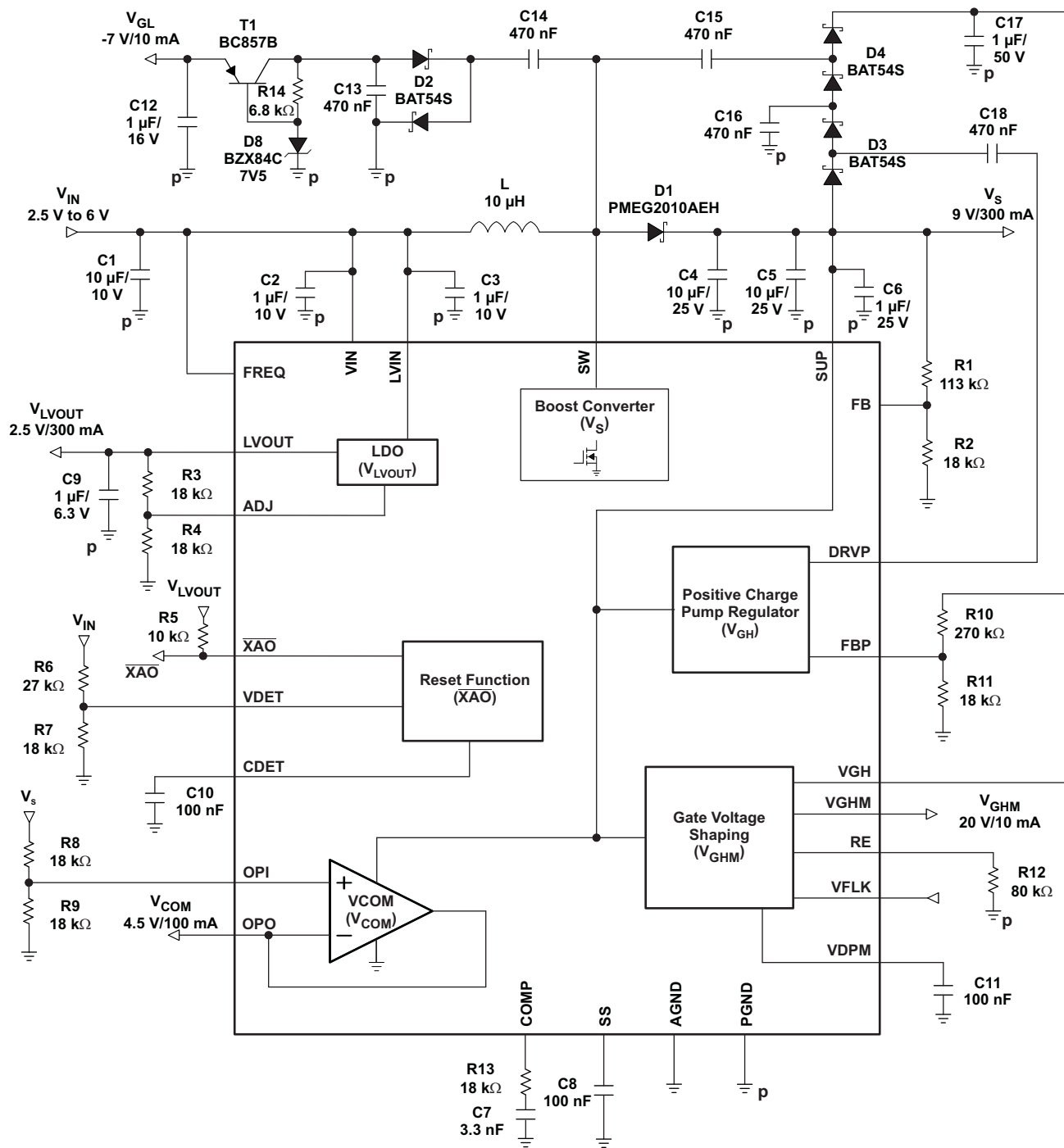

Figure 28. TPS65146 Typical Application with Positive Charge Pump in Tripler Mode Configuration

PACKAGING INFORMATION

Orderable Device	Status (1)	Package Type	Package Drawing	Pins	Package Qty	Eco Plan (2)	Lead/Ball Finish	MSL Peak Temp (3)	Op Temp (°C)	Top-Side Markings (4)	Samples
TPS65146RGER	ACTIVE	VQFN	RGE	24	3000	Green (RoHS & no Sb/Br)	CU NIPDAU	Level-2-260C-1 YEAR	-40 to 85	CEZ	Samples

(1) The marketing status values are defined as follows:

ACTIVE: Product device recommended for new designs.

LIFEBUY: TI has announced that the device will be discontinued, and a lifetime-buy period is in effect.

NRND: Not recommended for new designs. Device is in production to support existing customers, but TI does not recommend using this part in a new design.

PREVIEW: Device has been announced but is not in production. Samples may or may not be available.

OBSOLETE: TI has discontinued the production of the device.

(2) Eco Plan - The planned eco-friendly classification: Pb-Free (RoHS), Pb-Free (RoHS Exempt), or Green (RoHS & no Sb/Br) - please check <http://www.ti.com/productcontent> for the latest availability information and additional product content details.

TBD: The Pb-Free/Green conversion plan has not been defined.

Pb-Free (RoHS): TI's terms "Lead-Free" or "Pb-Free" mean semiconductor products that are compatible with the current RoHS requirements for all 6 substances, including the requirement that lead not exceed 0.1% by weight in homogeneous materials. Where designed to be soldered at high temperatures, TI Pb-Free products are suitable for use in specified lead-free processes.

Pb-Free (RoHS Exempt): This component has a RoHS exemption for either 1) lead-based flip-chip solder bumps used between the die and package, or 2) lead-based die adhesive used between the die and leadframe. The component is otherwise considered Pb-Free (RoHS compatible) as defined above.

Green (RoHS & no Sb/Br): TI defines "Green" to mean Pb-Free (RoHS compatible), and free of Bromine (Br) and Antimony (Sb) based flame retardants (Br or Sb do not exceed 0.1% by weight in homogeneous material)

(3) MSL, Peak Temp. -- The Moisture Sensitivity Level rating according to the JEDEC industry standard classifications, and peak solder temperature.

(4) Multiple Top-Side Markings will be inside parentheses. Only one Top-Side Marking contained in parentheses and separated by a "~" will appear on a device. If a line is indented then it is a continuation of the previous line and the two combined represent the entire Top-Side Marking for that device.

Important Information and Disclaimer: The information provided on this page represents TI's knowledge and belief as of the date that it is provided. TI bases its knowledge and belief on information provided by third parties, and makes no representation or warranty as to the accuracy of such information. Efforts are underway to better integrate information from third parties. TI has taken and continues to take reasonable steps to provide representative and accurate information but may not have conducted destructive testing or chemical analysis on incoming materials and chemicals. TI and TI suppliers consider certain information to be proprietary, and thus CAS numbers and other limited information may not be available for release.

In no event shall TI's liability arising out of such information exceed the total purchase price of the TI part(s) at issue in this document sold by TI to Customer on an annual basis.

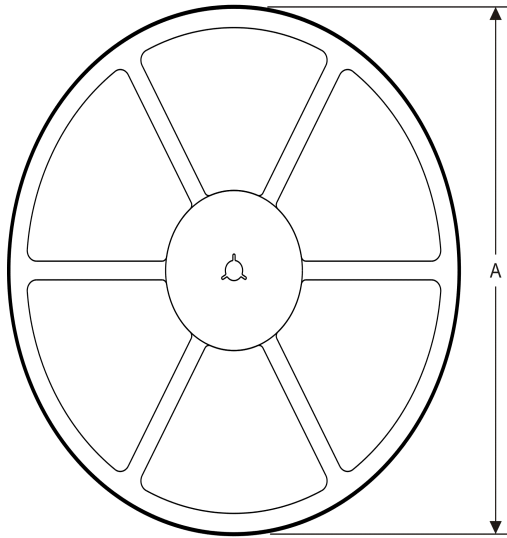
TAPE AND REEL INFORMATION
REEL DIMENSIONS

TAPE DIMENSIONS

A0	Dimension designed to accommodate the component width
B0	Dimension designed to accommodate the component length
K0	Dimension designed to accommodate the component thickness
W	Overall width of the carrier tape
P1	Pitch between successive cavity centers

TAPE AND REEL INFORMATION

*All dimensions are nominal

Device	Package Type	Package Drawing	Pins	SPQ	Reel Diameter (mm)	Reel Width W1 (mm)	A0 (mm)	B0 (mm)	K0 (mm)	P1 (mm)	W (mm)	Pin1 Quadrant
TPS65146RGER	VQFN	RGE	24	3000	330.0	12.4	4.25	4.25	1.15	8.0	12.0	Q2

TAPE AND REEL BOX DIMENSIONS



*All dimensions are nominal

Device	Package Type	Package Drawing	Pins	SPQ	Length (mm)	Width (mm)	Height (mm)
TPS65146RGER	VQFN	RGE	24	3000	367.0	367.0	35.0

GENERIC PACKAGE VIEW

RGE 24

VQFN - 1 mm max height

PLASTIC QUAD FLATPACK - NO LEAD

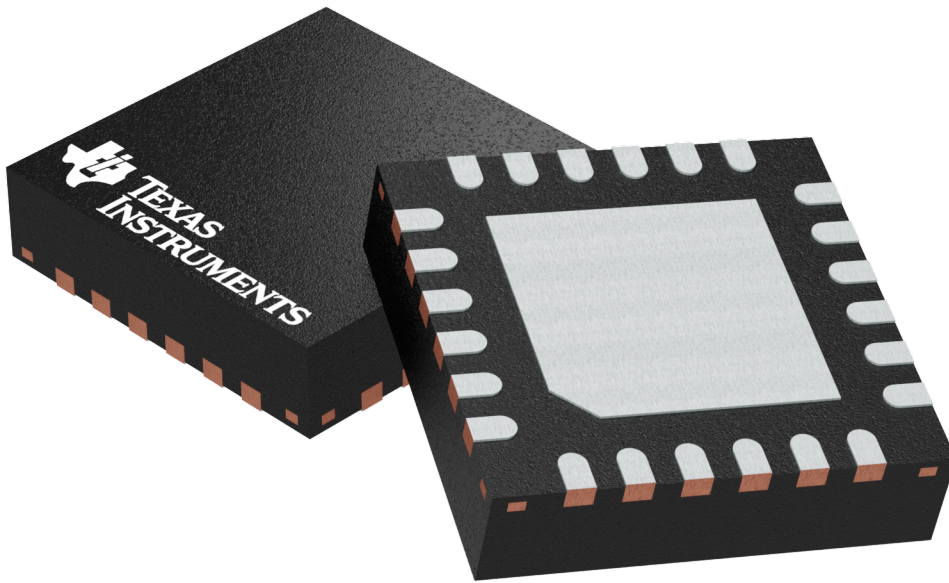

Images above are just a representation of the package family, actual package may vary.
Refer to the product data sheet for package details.

4204104/H

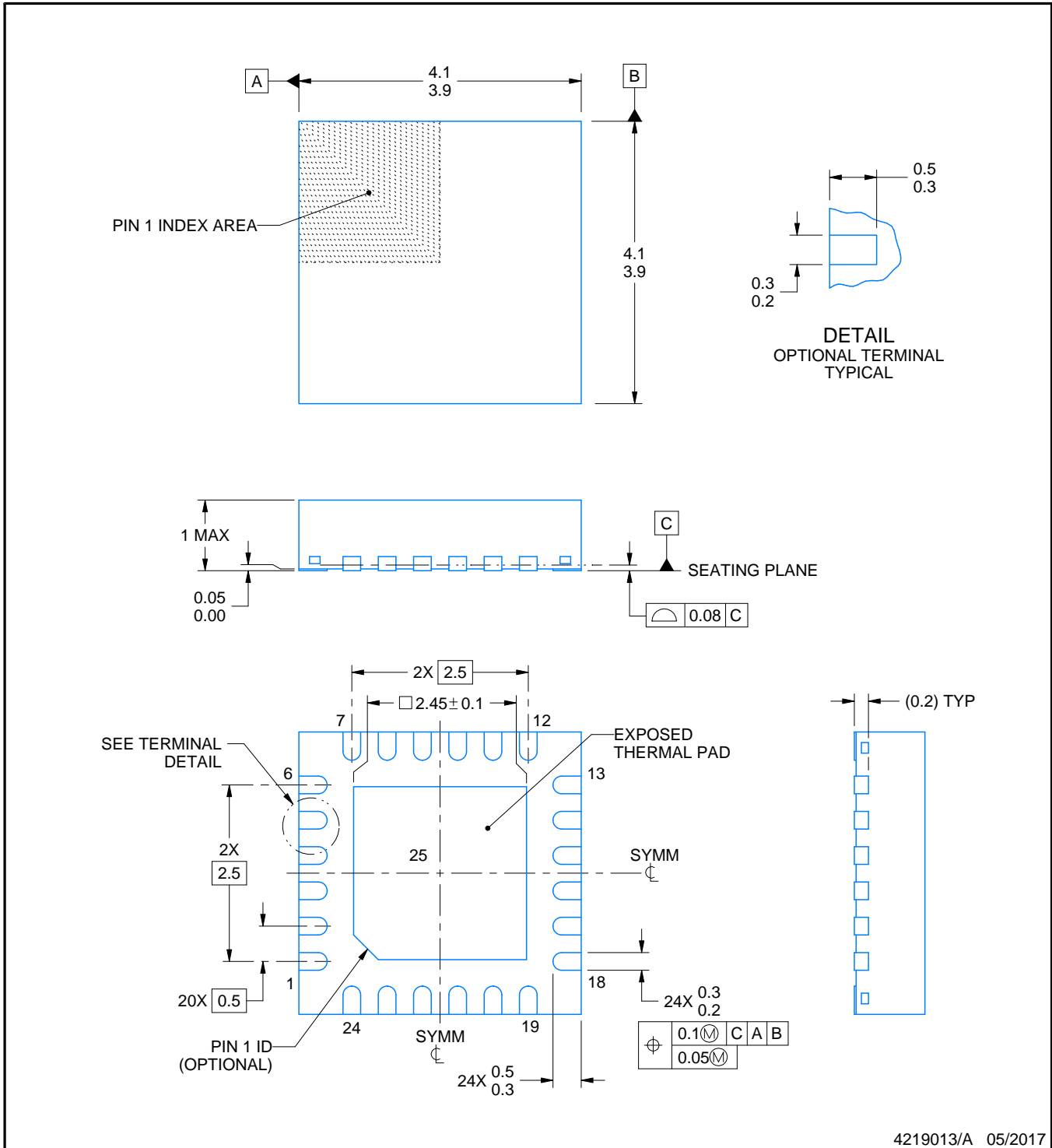
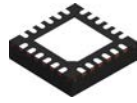

4219013/A 05/2017

NOTES:

1. All linear dimensions are in millimeters. Any dimensions in parenthesis are for reference only. Dimensioning and tolerancing per ASME Y14.5M.
2. This drawing is subject to change without notice.
3. The package thermal pad must be soldered to the printed circuit board for thermal and mechanical performance.

EXAMPLE STENCIL DESIGN

RGE0024B

VQFN - 1 mm max height

PLASTIC QUAD FLATPACK - NO LEAD

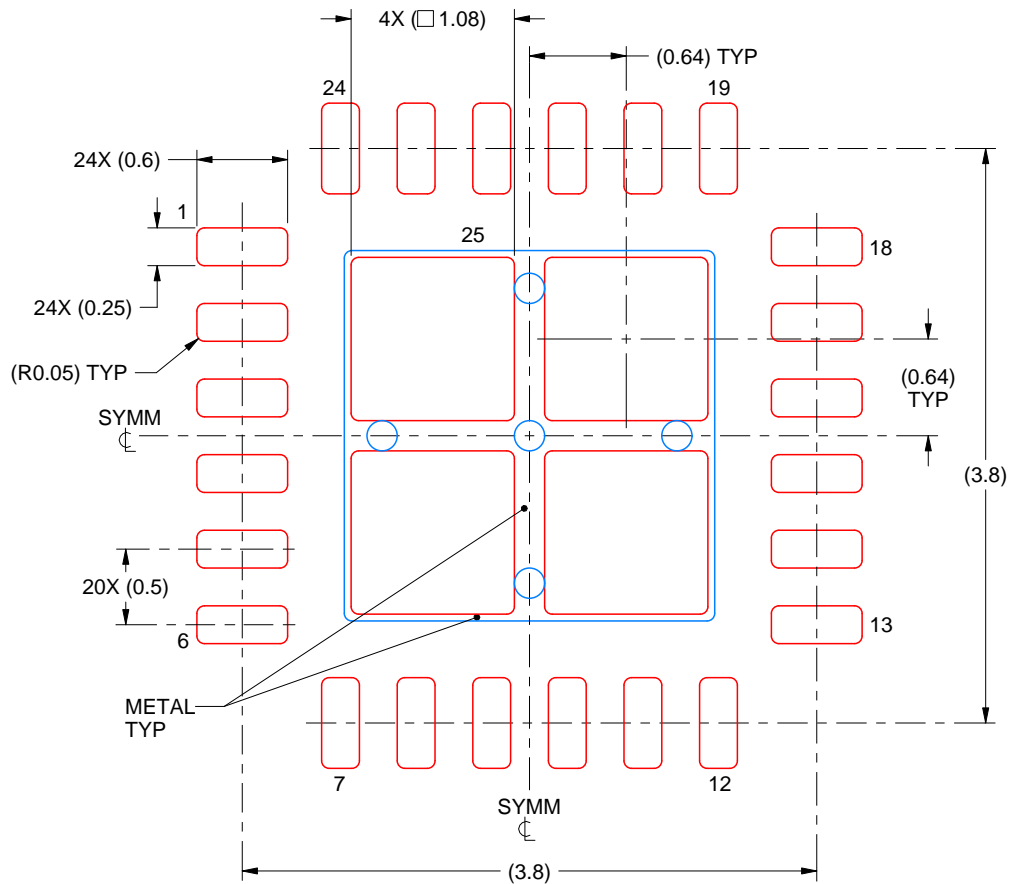

SOLDER PASTE EXAMPLE
BASED ON 0.125 mm THICK STENCIL

EXPOSED PAD 25
78% PRINTED SOLDER COVERAGE BY AREA UNDER PACKAGE
SCALE:20X

4219013/A 05/2017

NOTES: (continued)

6. Laser cutting apertures with trapezoidal walls and rounded corners may offer better paste release. IPC-7525 may have alternate design recommendations.

IMPORTANT NOTICE

Texas Instruments Incorporated (TI) reserves the right to make corrections, enhancements, improvements and other changes to its semiconductor products and services per JESD46, latest issue, and to discontinue any product or service per JESD48, latest issue. Buyers should obtain the latest relevant information before placing orders and should verify that such information is current and complete.

TI's published terms of sale for semiconductor products (<http://www.ti.com/sc/docs/stdterms.htm>) apply to the sale of packaged integrated circuit products that TI has qualified and released to market. Additional terms may apply to the use or sale of other types of TI products and services.

Reproduction of significant portions of TI information in TI data sheets is permissible only if reproduction is without alteration and is accompanied by all associated warranties, conditions, limitations, and notices. TI is not responsible or liable for such reproduced documentation. Information of third parties may be subject to additional restrictions. Resale of TI products or services with statements different from or beyond the parameters stated by TI for that product or service voids all express and any implied warranties for the associated TI product or service and is an unfair and deceptive business practice. TI is not responsible or liable for any such statements.

Buyers and others who are developing systems that incorporate TI products (collectively, "Designers") understand and agree that Designers remain responsible for using their independent analysis, evaluation and judgment in designing their applications and that Designers have full and exclusive responsibility to assure the safety of Designers' applications and compliance of their applications (and of all TI products used in or for Designers' applications) with all applicable regulations, laws and other applicable requirements. Designer represents that, with respect to their applications, Designer has all the necessary expertise to create and implement safeguards that (1) anticipate dangerous consequences of failures, (2) monitor failures and their consequences, and (3) lessen the likelihood of failures that might cause harm and take appropriate actions. Designer agrees that prior to using or distributing any applications that include TI products, Designer will thoroughly test such applications and the functionality of such TI products as used in such applications.

TI's provision of technical, application or other design advice, quality characterization, reliability data or other services or information, including, but not limited to, reference designs and materials relating to evaluation modules, (collectively, "TI Resources") are intended to assist designers who are developing applications that incorporate TI products; by downloading, accessing or using TI Resources in any way, Designer (individually or, if Designer is acting on behalf of a company, Designer's company) agrees to use any particular TI Resource solely for this purpose and subject to the terms of this Notice.

TI's provision of TI Resources does not expand or otherwise alter TI's applicable published warranties or warranty disclaimers for TI products, and no additional obligations or liabilities arise from TI providing such TI Resources. TI reserves the right to make corrections, enhancements, improvements and other changes to its TI Resources. TI has not conducted any testing other than that specifically described in the published documentation for a particular TI Resource.

Designer is authorized to use, copy and modify any individual TI Resource only in connection with the development of applications that include the TI product(s) identified in such TI Resource. NO OTHER LICENSE, EXPRESS OR IMPLIED, BY ESTOPPEL OR OTHERWISE TO ANY OTHER TI INTELLECTUAL PROPERTY RIGHT, AND NO LICENSE TO ANY TECHNOLOGY OR INTELLECTUAL PROPERTY RIGHT OF TI OR ANY THIRD PARTY IS GRANTED HEREIN, including but not limited to any patent right, copyright, mask work right, or other intellectual property right relating to any combination, machine, or process in which TI products or services are used. Information regarding or referencing third-party products or services does not constitute a license to use such products or services, or a warranty or endorsement thereof. Use of TI Resources may require a license from a third party under the patents or other intellectual property of the third party, or a license from TI under the patents or other intellectual property of TI.

TI RESOURCES ARE PROVIDED "AS IS" AND WITH ALL FAULTS. TI DISCLAIMS ALL OTHER WARRANTIES OR REPRESENTATIONS, EXPRESS OR IMPLIED, REGARDING RESOURCES OR USE THEREOF, INCLUDING BUT NOT LIMITED TO ACCURACY OR COMPLETENESS, TITLE, ANY EPIDEMIC FAILURE WARRANTY AND ANY IMPLIED WARRANTIES OF MERCHANTABILITY, FITNESS FOR A PARTICULAR PURPOSE, AND NON-INFRINGEMENT OF ANY THIRD PARTY INTELLECTUAL PROPERTY RIGHTS. TI SHALL NOT BE LIABLE FOR AND SHALL NOT DEFEND OR INDEMNIFY DESIGNER AGAINST ANY CLAIM, INCLUDING BUT NOT LIMITED TO ANY INFRINGEMENT CLAIM THAT RELATES TO OR IS BASED ON ANY COMBINATION OF PRODUCTS EVEN IF DESCRIBED IN TI RESOURCES OR OTHERWISE. IN NO EVENT SHALL TI BE LIABLE FOR ANY ACTUAL, DIRECT, SPECIAL, COLLATERAL, INDIRECT, PUNITIVE, INCIDENTAL, CONSEQUENTIAL OR EXEMPLARY DAMAGES IN CONNECTION WITH OR ARISING OUT OF TI RESOURCES OR USE THEREOF, AND REGARDLESS OF WHETHER TI HAS BEEN ADVISED OF THE POSSIBILITY OF SUCH DAMAGES.

Unless TI has explicitly designated an individual product as meeting the requirements of a particular industry standard (e.g., ISO/TS 16949 and ISO 26262), TI is not responsible for any failure to meet such industry standard requirements.

Where TI specifically promotes products as facilitating functional safety or as compliant with industry functional safety standards, such products are intended to help enable customers to design and create their own applications that meet applicable functional safety standards and requirements. Using products in an application does not by itself establish any safety features in the application. Designers must ensure compliance with safety-related requirements and standards applicable to their applications. Designer may not use any TI products in life-critical medical equipment unless authorized officers of the parties have executed a special contract specifically governing such use. Life-critical medical equipment is medical equipment where failure of such equipment would cause serious bodily injury or death (e.g., life support, pacemakers, defibrillators, heart pumps, neurostimulators, and implantables). Such equipment includes, without limitation, all medical devices identified by the U.S. Food and Drug Administration as Class III devices and equivalent classifications outside the U.S.

TI may expressly designate certain products as completing a particular qualification (e.g., Q100, Military Grade, or Enhanced Product). Designers agree that it has the necessary expertise to select the product with the appropriate qualification designation for their applications and that proper product selection is at Designers' own risk. Designers are solely responsible for compliance with all legal and regulatory requirements in connection with such selection.

Designer will fully indemnify TI and its representatives against any damages, costs, losses, and/or liabilities arising out of Designer's non-compliance with the terms and provisions of this Notice.

Looking for pricing, stock, or lifecycle information?

Click below to explore more details on WIN SOURCE:

 [View TPS65146RGER](#) on WIN SOURCE

 [Texas Instruments](#) Information

Optimize Your Supply Chain with WIN SOURCE Solutions

-  Global Sourcing Solution
-  Obsolete Management
-  Cost Control Management
-  Shortage Management
-  Alternative Solution
-  Excess Inventory Management