

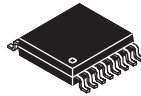

**THE DATASHEET OF
SN65LVDS349PW**





QUAD HIGH-SPEED DIFFERENTIAL RECEIVER

Check for Samples: [SN65LVDS349](#)

FEATURES

- Meets or Exceeds the Requirements of ANSI TIA/EIA-644A Standard
- Single-Channel Signaling Rates up to 560 Mbps
- -4 V to 5 V Common-Mode Input Voltage Range
- Flow-Through Architecture
- SN65LVDS349 Provides a Wide Common-Mode Range Replacement for the SN65LVDS048A or the DS90LV048A

APPLICATIONS

- Logic Level Translator
- Point-to-Point Baseband Data Transmission Over 100-Ω Media
- ECL/PECL-to-LVTTL Conversion
- Wireless Base Stations
- Central Office or PABX Switches

DESCRIPTION

The SN65LVDS349 is a high-speed, quadruple differential receiver with a wide common-mode input voltage range. This allows receipt of TIA/EIA-644 signals with up to 3-V of ground noise or a variety of differential and single-ended logic levels. The '349 is in a 16-pin package to match the industry-standard footprint of the DS90LV048. The '349 offers a flow-through architecture with all inputs on one side and outputs on the other to ease board layout and reduce crosstalk between receivers.

The LVDS349 provides 3x the standard's minimum common-mode noise voltage tolerance. The -4 V to 5 V common-mode range allows usage in harsh operating environments or accepts LVPECL, PECL, LVECL, ECL, CMOS, and LVCMOS levels without level shifting circuitry. See the Application Information Section for more details on the ECL/PECL to LVDS interface.

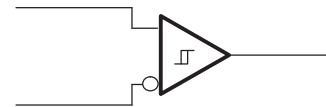
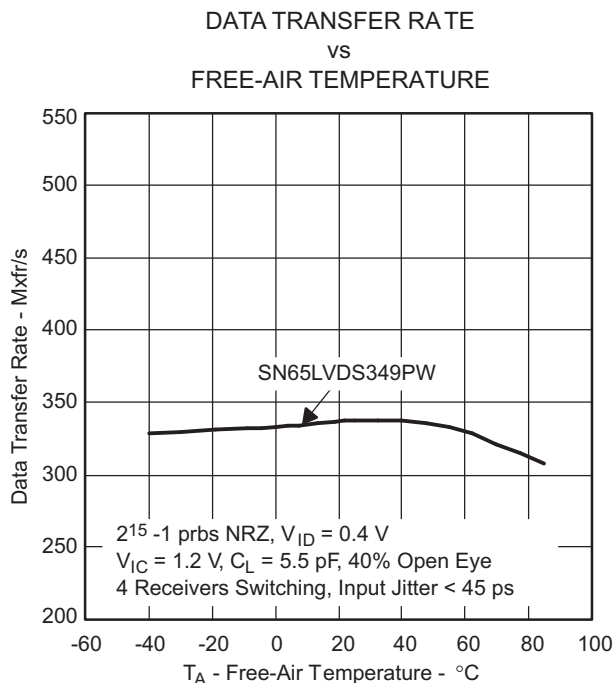

(One of four shown; failsafe circuit does not exist in LVDS349)



Please be aware that an important notice concerning availability, standard warranty, and use in critical applications of Texas Instruments semiconductor products and disclaimers thereto appears at the end of this data sheet.



These devices have limited built-in ESD protection. The leads should be shorted together or the device placed in conductive foam during storage or handling to prevent electrostatic damage to the MOS gates.

DESCRIPTION (CONTINUED)

Precise control of the differential input voltage thresholds allows for inclusion of 50 mV of input-voltage hysteresis to improve noise rejection. The differential input thresholds are still no more than ± 50 mV over the full input common-mode voltage range.

The receiver inputs can withstand ± 15 kV human-body model (HBM), with respect to ground, without damage. This provides reliability in cabled and other connections where potentially damaging noise is always a threat.

The intended application of these devices and signaling technique is for point-to-point baseband data transmission over controlled impedance media of approximately 100 Ω . The transmission media may be printed-circuit board traces, backplanes, or cables. The ultimate rate and distance of data transfer is dependent upon the attenuation characteristics of the media and the noise coupling to the environment.

The SN65LVDS349 is characterized for operation from -40°C to 85°C .

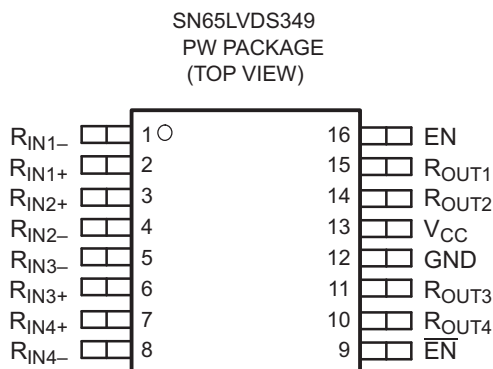

FUNCTIONAL BLOCK DIAGRAM (one of four receivers shown)

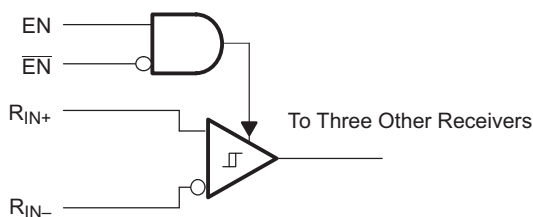

A. Failsafe circuit does not exist in LVDS349

Table 1. AVAILABLE OPTIONS⁽¹⁾

PART NUMBER ⁽²⁾	PACKAGE TYPE	PACKAGE MARKING
SN65LVDS349PW	TSSOP	DL349

(1) For the most current package and ordering information, see the Package Option Addendum at the end of this document, or visit the device product folder on ti.com.

(2) Add the R suffix to the device type (e.g., SN65LVDS349PWR) for taped and reeled carrier.

Table 2. FUNCTION TABLE⁽¹⁾

349 DEVICE			
INPUTS			OUTPUTS
$V_{ID} = V_{RIN+} - V_{RIN-}$	EN	\overline{EN}	R_{OUT}
$V_{ID} \geq 50 \text{ mV}$	H	L or OPEN	H
$-50 \text{ mV} < V_{ID} < 50 \text{ mV}$	H	L or OPEN	?
$V_{ID} \leq -50 \text{ mV}$	H	L or OPEN	L
Open	H	L or OPEN	? ⁽²⁾⁽³⁾
X	L or OPEN	X	Z
	X	H	Z

- (1) This logic table is at dc condition.
- (2) Outputs can toggle with inputs disconnected.
- (3) ? indicates state is indeterminate

EQUIVALENT INPUT AND OUTPUT SCHEMATIC DIAGRAMS

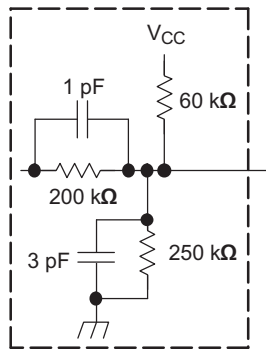

Attenuation Network

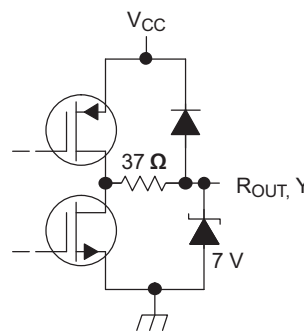
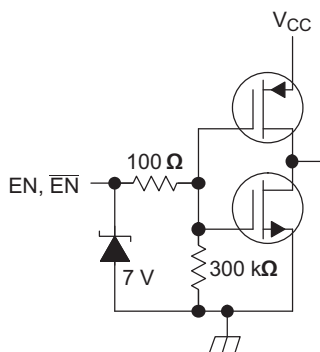
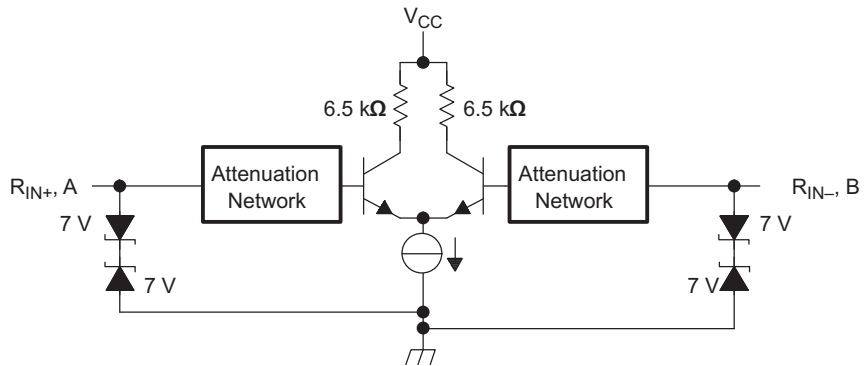

ABSOLUTE MAXIMUM RATINGS

over operating free-air temperature range (unless otherwise noted)⁽¹⁾

			UNIT
Supply voltage range ⁽²⁾ , V_{CC} , V_{CCA} , V_{CCD1} , and V_{CCD2}			-0.5 V to 4 V
Voltage range	Enables, R_{OUT} , or Y		-0.5 V to 6 V
	R_{IN+} , R_{IN-} , A or B		-5 V to 6 V
Electrostatic discharge	Human body model ⁽³⁾	A, B, R_{IN+} , R_{IN-} and GND	±15 kV
		All pins	±7 kV
	Charged-device model ⁽⁴⁾	All pins	±500 V
Continuous power dissipation			See Dissipation Rating Table
Storage temperature range			-65°C to 150°C

- (1) Stresses beyond those listed under "absolute maximum ratings" may cause permanent damage to the device. These are stress ratings only, and functional operation of the device at these or any other conditions beyond those indicated under "recommended operating conditions" is not implied. Exposure to absolute-maximum-rated conditions for extended periods may affect device reliability.
- (2) All voltage values, except differential I/O bus voltages, are with respect to network ground terminal (GND, AGND).
- (3) Tested in accordance with JEDEC Standard 22, Test Method A114-A.
- (4) Tested in accordance with JEDEC Standard 22, Test Method C101.

THERMAL INFORMATION

THERMAL METRIC ⁽¹⁾		SN65LVDS349	UNITS
		PW	
		16 PINS	
θ_{JA}	Junction-to-ambient thermal resistance ⁽²⁾	111.9	°C/W
$\theta_{JC(top)}$	Junction-to-case(top) thermal resistance ⁽³⁾	33.3	
θ_{JB}	Junction-to-board thermal resistance ⁽⁴⁾	52.4	
ψ_{JT}	Junction-to-top characterization parameter ⁽⁵⁾	2.0	
ψ_{JB}	Junction-to-board characterization parameter ⁽⁶⁾	51.2	
$\theta_{JC(bottom)}$	Junction-to-case(bottom) thermal resistance ⁽⁷⁾	N/A	

- (1) For more information about traditional and new thermal metrics, see the *IC Package Thermal Metrics* application report, [SPRA953](#).
- (2) The junction-to-ambient thermal resistance under natural convection is obtained in a simulation on a JEDEC-standard, high-K board, as specified in JESD51-7, in an environment described in JESD51-2a.
- (3) The junction-to-case (top) thermal resistance is obtained by simulating a cold plate test on the package top. No specific JEDEC-standard test exists, but a close description can be found in the ANSI SEMI standard G30-88.
- (4) The junction-to-board thermal resistance is obtained by simulating in an environment with a ring cold plate fixture to control the PCB temperature, as described in JESD51-8.
- (5) The junction-to-top characterization parameter, ψ_{JT} , estimates the junction temperature of a device in a real system and is extracted from the simulation data for obtaining θ_{JA} , using a procedure described in JESD51-2a (sections 6 and 7).
- (6) The junction-to-board characterization parameter, ψ_{JB} , estimates the junction temperature of a device in a real system and is extracted from the simulation data for obtaining θ_{JA} , using a procedure described in JESD51-2a (sections 6 and 7).
- (7) The junction-to-case (bottom) thermal resistance is obtained by simulating a cold plate test on the exposed (power) pad. No specific JEDEC standard test exists, but a close description can be found in the ANSI SEMI standard G30-88.

RECOMMENDED OPERATING CONDITIONS

		MIN	NOM	MAX	UNIT		
$V_{CC}, V_{CCA}, V_{CCD1},$ and V_{CCD2}	Supply voltage	3	3.3	3.6	V		
V_{IH}	High-level input voltage	Enables		5	V		
V_{IL}	Low-level input voltage	Enables		0.8	V		
	Magnitude of differential input voltage	$ V_{ID} $ (LVDS349)		3	V		
	Input voltage (any combination of common mode or input signals)				-4	5	V
T_A	Operating free-air temperature				-40	85	°C

ELECTRICAL CHARACTERISTICS

over recommended operating conditions (unless otherwise noted)

PARAMETER		TEST CONDITIONS	MIN	TYP ⁽¹⁾	MAX	UNIT	
V_{ITH1}	Positive-going differential input voltage threshold	See Figure 1 and Figure 2			50	mV	
V_{ITH2}	Negative-going differential input voltage threshold	See Figure 1	-50			mV	
$V_{ID(HYS)}$	Differential input voltage hysteresis, $V_{ITH1} - V_{ITH2}$			50		mV	
V_{OH}	High-level output voltage	$I_{OH} = -4$ mA	2.4			V	
V_{OL}	Low-level output voltage	$I_{OL} = 4$ mA			0.4	V	
I_{CC}	Supply current	LVDS349	Enabled, EN at V_{CC} , \overline{EN} at 0 V, No load		16	20	mA
			Disabled, EN at 0 or \overline{EN} at V_{CC}		1.1	4	
I_I	Input current (RIN+, RIN-, A or B inputs)	LVDS349	$V_I = -4$ V, Other input open		-75	0	μ A
			$0 \text{ V} \leq V_I \leq 2.4$ V, Other input 1.2 V		-20	0	
			$V_I = 5$ V, Other input open		0	40	
$I_{I(OFF)}$	Power-off input current (RIN+, RIN-, A or B inputs)	LVDS349	$V_{CC} = 1.5$ V, $V_I = -4$ V or 5 V, Other input open		-50	50	μ A
			$V_{CC} = 1.5$ V, $0 \text{ V} \leq V_I \leq 2.4$ V, Other input at 1.2 V		-20	20	
I_{ID}	Differential input current ($I_{RIN+} - I_{RIN-}$, or $I_{IA} - I_{IB}$)	LVDS349	$V_{ID} = 100$ mV, $V_{IC} = -3.9$ V or 4.9 V		-4	4	μ A
I_{IH}	High-level input current	Enables	$V_{IH} = 2$ V		0	10	μ A
I_{IL}	Low-level input current	Enables	$V_{IL} = 0.8$ V		0	10	μ A
I_{OZ}	High-impedance output current		$V_O = 0$ V		-10	10	μ A
C_{IN}	Input capacitance, RIN+, RIN- input to GND or A or B input to AGND		$V_I = 0.4 \sin(4E6\pi ft) + 0.5$ V			5	pF

(1) All typical values are at 25°C and with a 3.3-V supply.

SWITCHING CHARACTERISTICS

over recommended operating conditions (unless otherwise noted)

PARAMETER		TEST CONDITIONS	MIN	TYP ⁽¹⁾	MAX	UNIT
t_{PLH}	Propagation delay time, low-to-high-level output	$C_L = 10$ pF, See Figure 3	2.5	4	6	ns
t_{PHL}	Propagation delay time, high-to-low-level output		2.5	4	6	ns
$t_{sk(p)}$	Pulse skew ($ t_{pHL1} - t_{pLH1} $)			200		ps
$t_{sk(o)}$	Output skew ⁽²⁾			150		ps
$t_{sk(pp)}$	Part-to-part skew ⁽³⁾				1	ns
t_r	Output signal rise time			1.2		ns
t_f	Output signal fall time			1		ns
t_r	Output signal rise time	$C_L = 1$ pF, See Figure 3		650		ps
t_f	Output signal fall time			400		ps
t_{PHZ}	Propagation delay time, high-level-to-high-impedance output	See Figure 4		5	9	ns
t_{PLZ}	Propagation delay time, low-level-to-high-impedance output			5	9	ns
t_{PZH}	Propagation delay time, high-impedance-to-high-level output			8	12	ns
t_{PZL}	Propagation delay time, high-impedance-to-low-level output			8	12	ns

- (1) All typical values are at 25°C and with a 3.3-V supply.
- (2) $t_{sk(o)}$ is the magnitude of the time difference between the t_{pHL} or t_{pLH} of all receivers of a single device with all of their inputs connected together.
- (3) $t_{sk(pp)}$ is the magnitude of the difference in propagation delay times between any specified terminals of two devices when both devices operate with the same supply voltages, at the same temperature, and have identical packages and test circuits.

PARAMETER MEASUREMENT INFORMATION

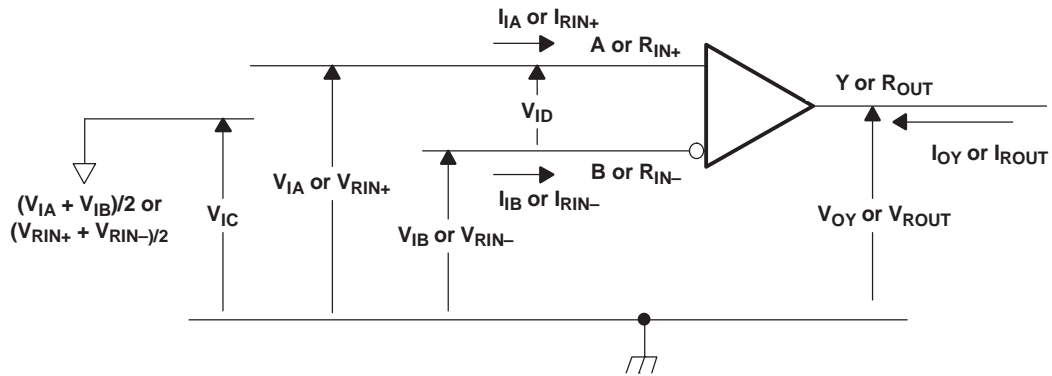
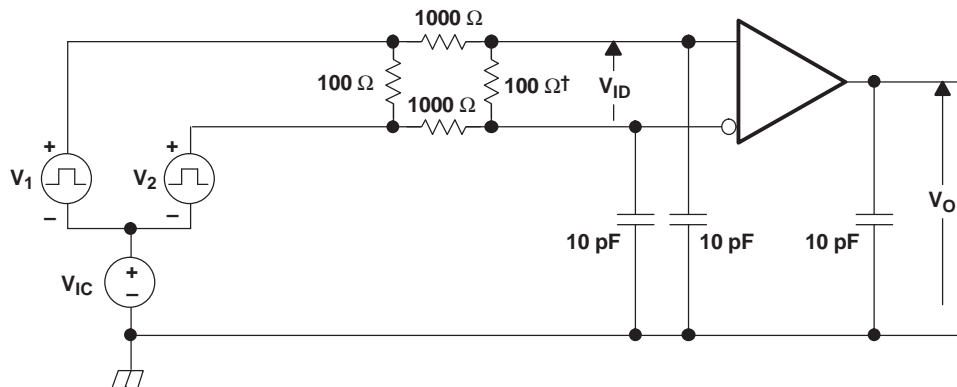
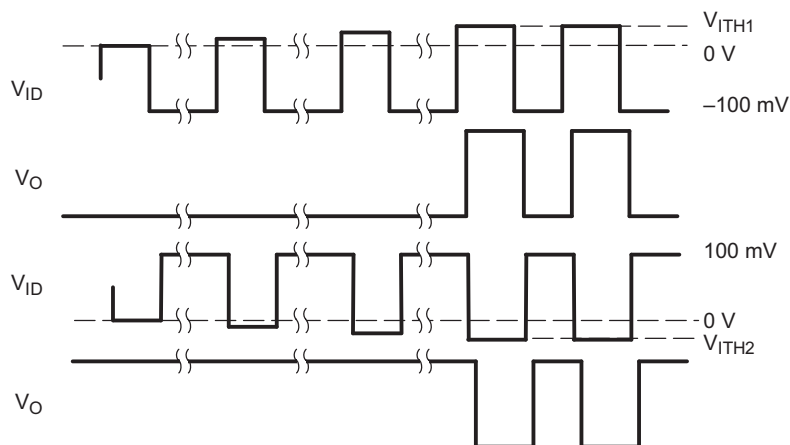

Figure 1. Voltage and Current Definitions



- A. Fixture capacitance $\pm 20\%$.
- B. Resistors are metal film, 1% tolerance, and surface mount



- A. Input signal of 3 MHz, duty cycle of $50 \pm 0.2\%$, and transition time of < 1 ns.

Figure 2. V_{ITH1} and V_{ITH2} Input Voltage Threshold Test Circuit and Definitions

PARAMETER MEASUREMENT INFORMATION (continued)

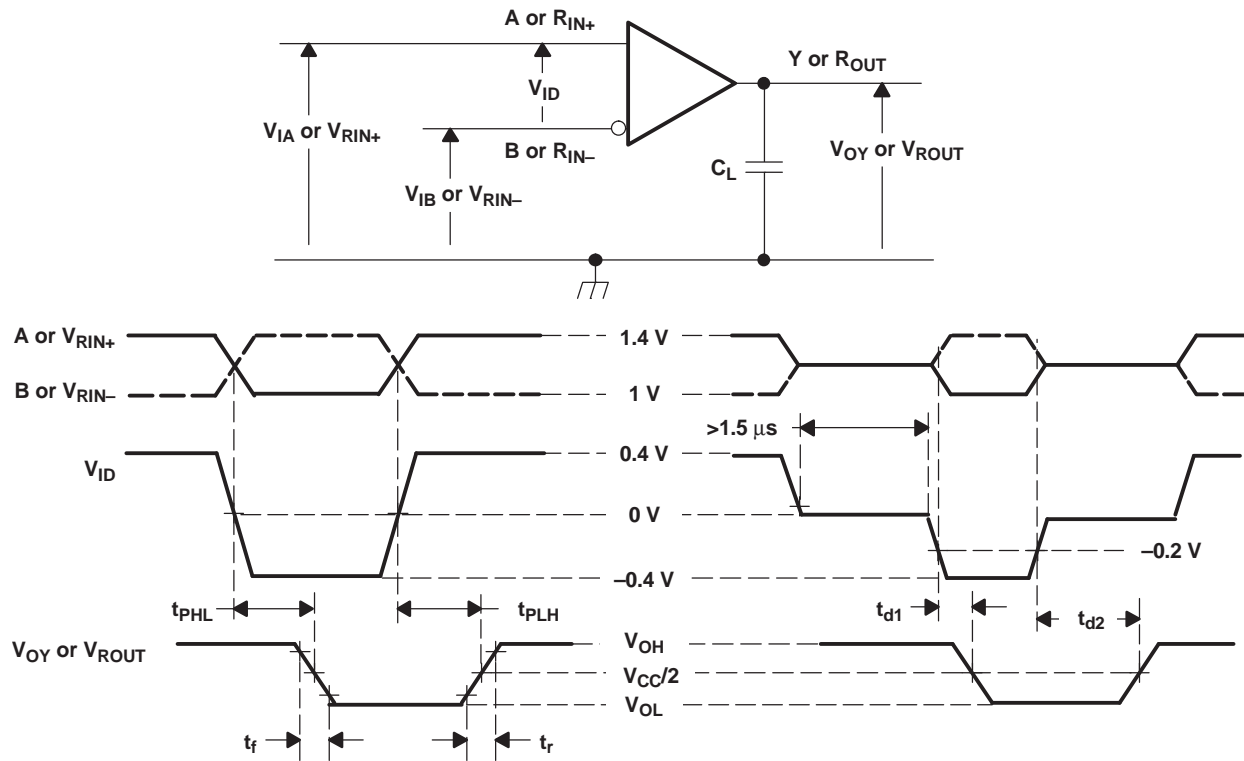

- A. All input pulses are supplied by a generator having the following characteristics: t_r or t_f ≤ 1 ns, signaling rate = 250 kHz, duty cycle = 50 ±2%, C_L includes instrumentation and fixture capacitance within 0,06 mm of the D.U.T and is ±20%.

Figure 3. Timing Test Circuit and Waveforms

PARAMETER MEASUREMENT INFORMATION (continued)

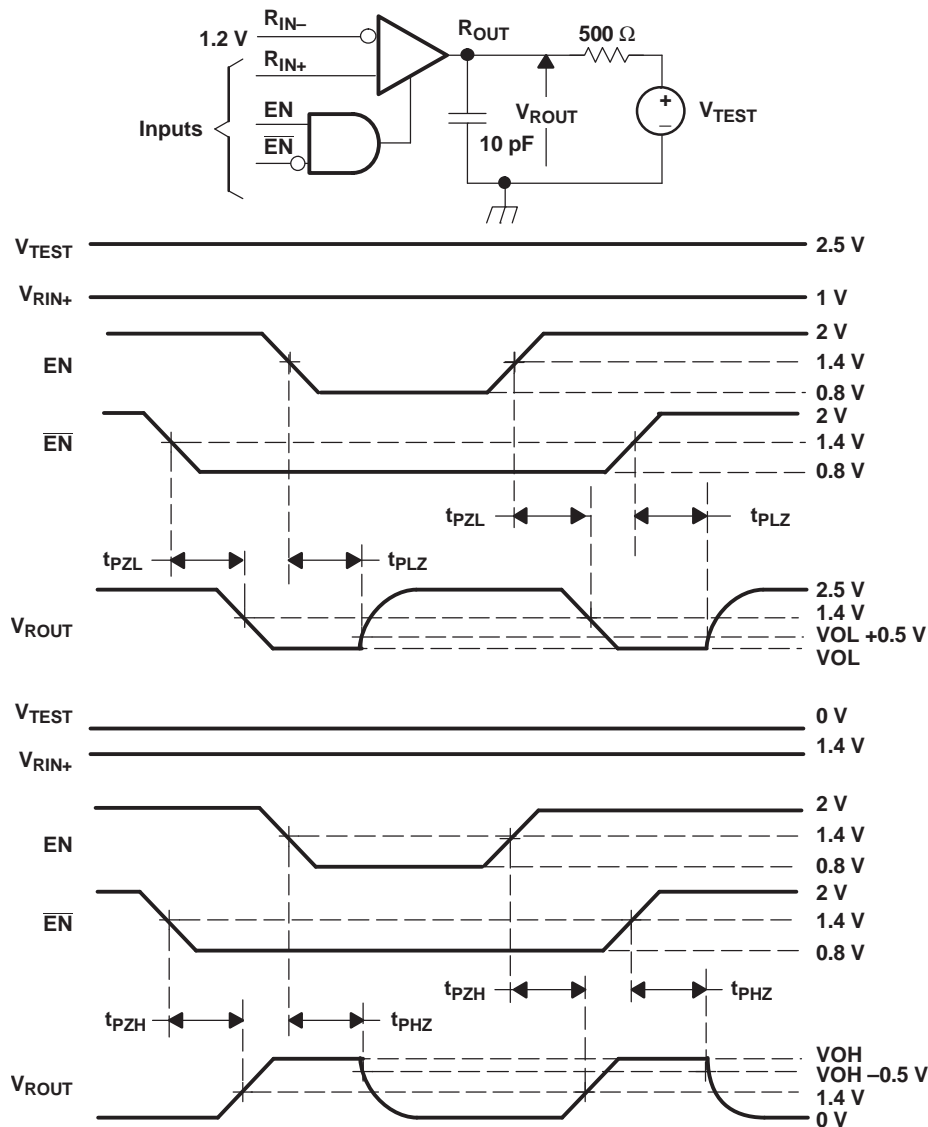

- A. All input pulses are supplied by a generator having the following characteristics: t_r or $t_f \leq 1$ ns, signaling rate = 500 kHz, duty cycle = $50 \pm 2\%$, C_L includes instrumentation and fixture capacitance within 0,06 mm of the D.U.T and is $\pm 20\%$.

Figure 4. Enable/Disable Time Test Circuit and Waveforms

TYPICAL CHARACTERISTICS

**LOW-TO-HIGH PROPAGATION DELAY
vs
FREE-AIR TEMPERATURE**

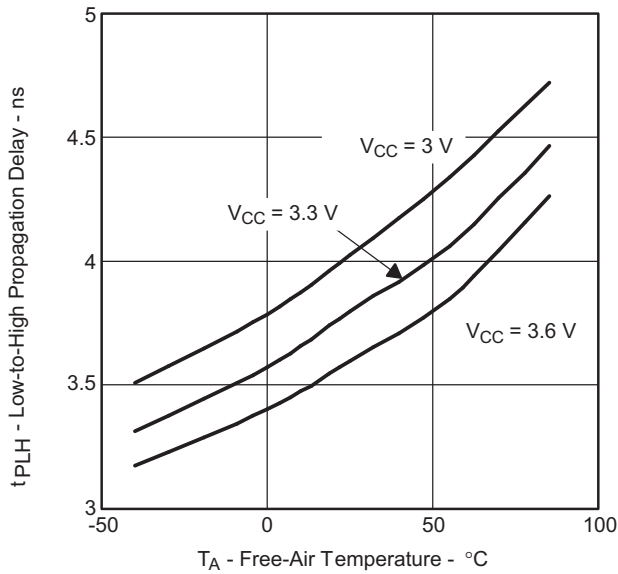

Figure 5.

**HIGH-TO-LOW PROPAGATION DELAY
vs
FREE-AIR TEMPERATURE**

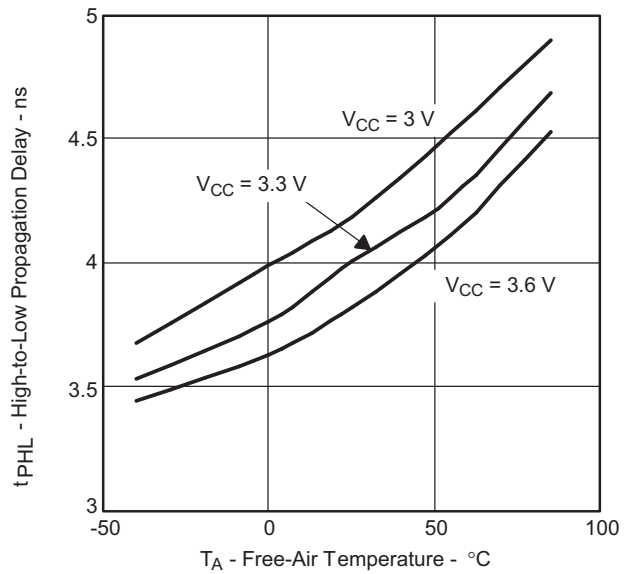

Figure 6.

**LOW-LEVEL OUTPUT CURRENT
vs
LOW-LEVEL OUTPUT VOLTAGE**

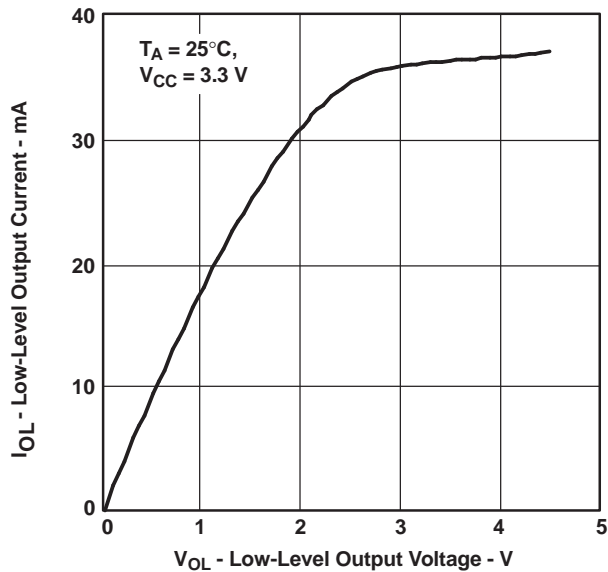

Figure 7.

**HIGH-LEVEL OUTPUT CURRENT
vs
HIGH-LEVEL OUTPUT VOLTAGE**

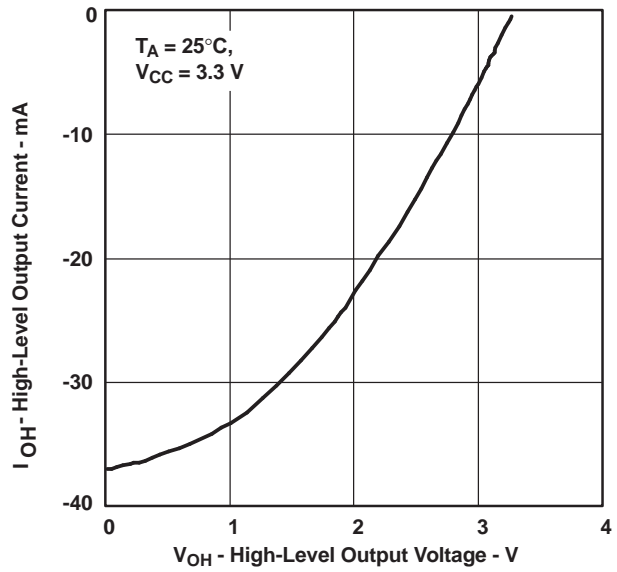

Figure 8.

TYPICAL CHARACTERISTICS (continued)

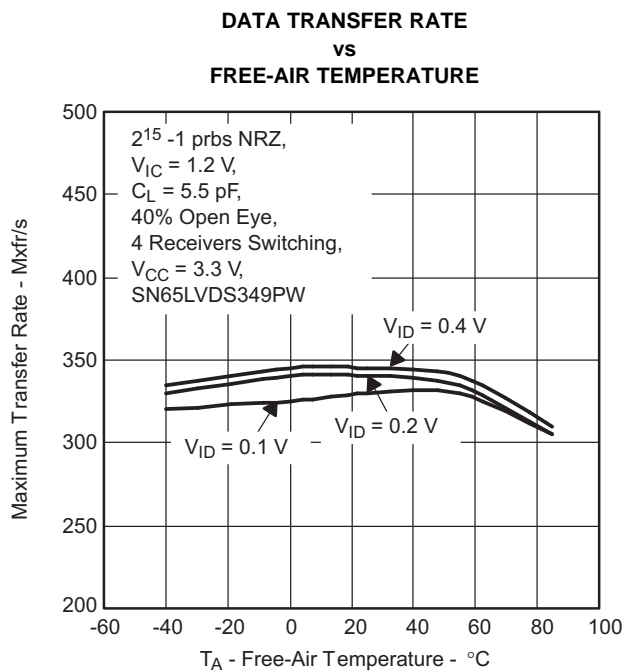

Figure 9.

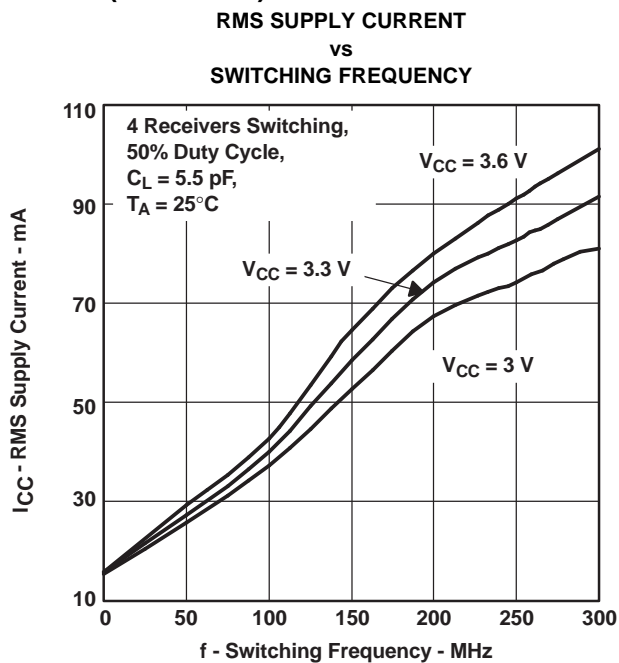

Figure 10.

2²³ -1 prbs NRZ, $T_A = 25^\circ\text{C}$, $C_L = 5.5\text{ pF}$,
 4 Receivers Switching, $V_{CC} = 3.3\text{ V}$

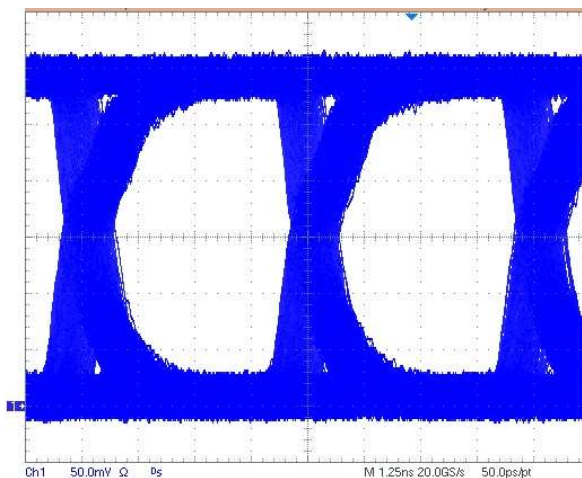

Figure 11. SN65LVDS349 Eye Pattern Running at 200 Mxfr/s

APPLICATION INFORMATION

IMPEDANCE MATCHING AND REFLECTIONS

A termination mismatch can result in reflections that degrade the signal at the load. A low source impedance causes the signal to alternate polarity at the load (oscillates) as shown in Figure 12. High source impedance results in the signal accumulating monotonically to the final value (stair step) as shown in Figure 13. Both of these modes result in a delay in valid signal and reduce the opening in the eye pattern. A 10% termination mismatch results in a 5% reflection ($r = Z_L - Z_O / Z_L + Z_O$), even a 1:3 mismatch absorbs half of the incoming signal. This shows that termination is important in the more critical cases, however, in a general sense, a rather large termination mismatch is not as critical when the differential output signal is much greater than the receiver sensitivity.

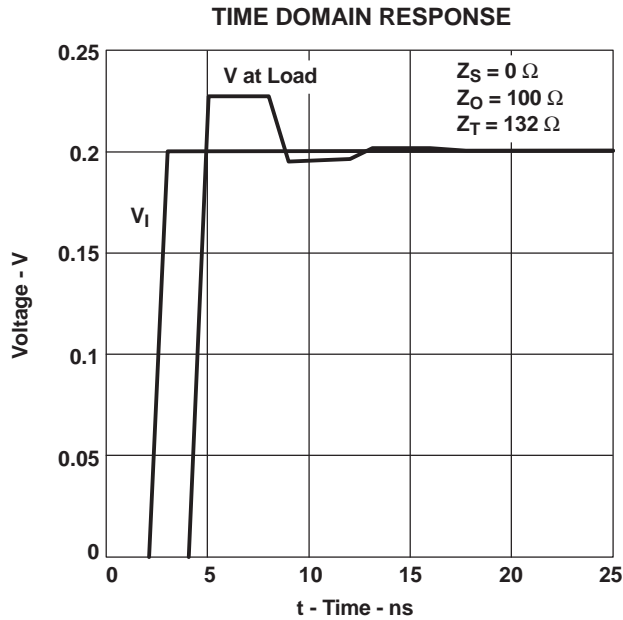

Figure 12. Low-Source Impedance

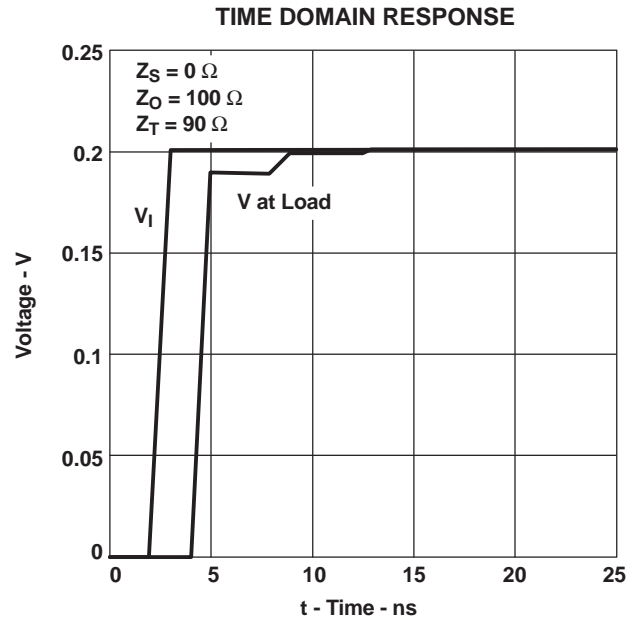

Figure 13. High-Source Impedance

For example, a 200-mV drive signal into a 100-Ω lossless transmission media with a termination resistor of 90 Ω to 132Ω results in ~227 mV to 189 mV into the receiver. This would typically be more than enough signal into a receiver with a sensitivity of ± 50 mV assuming no other disturbance or attenuation on the line. The other factors, which reduce the signal margin, do affect this and therefore it is important to match the impedance as closely as possible to allow more noise immunity at the receiver.

ACTIVE FAILSAFE FEATURE

A differential line receiver commonly has a failsafe circuit to prevent it from switching on input noise. Current LVDS failsafe solutions require either external components with subsequent reductions in signal quality or integrated solutions with limited application.

In the SN65LVDS349, the failsafe circuit does not exist. Thus the output can switch if there is noise on the input lines.

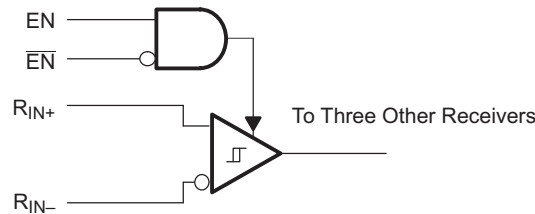

Figure 14. Failsafe Circuit Does Not Exist in the SN65LVDS349

ECL/PECL-to-LVTTL CONVERSION WITH TI LVDS RECEIVER

The various versions of emitter-coupled logic (i.e., ECL, PECL, and LVPECL) are often the physical layer of choice for system designers. Designers know that established technology is capable of high-speed data transmission. In the past, system requirements often forced the selection of ECL. Now technologies like LVDS provide designers with another alternative. While the total exchange of ECL for LVDS may not be a design option, designers have been able to take advantage of LVDS by implementing a small resistor divider network at the input of the LVDS receiver. TI has taken the next step by introducing a wide common-mode LVDS receiver (no divider network required) which can be connected directly to an ECL driver with only the termination bias voltage required for ECL termination ($V_{CC} - 2\text{ V}$).

Figure 15 shows the use of an LV/PECL driver driving 5 meters of CAT-5 cable and being received by TI's wide common-mode receiver and the resulting eye-pattern. The values for R3 are required in order to provide a resistor path to ground for the LV/PECL driver. With no resistor divider, R1 simply needs to match the characteristic load impedance of $50\ \Omega$. The R2 resistor is a small value intended to minimize common-mode reflections.

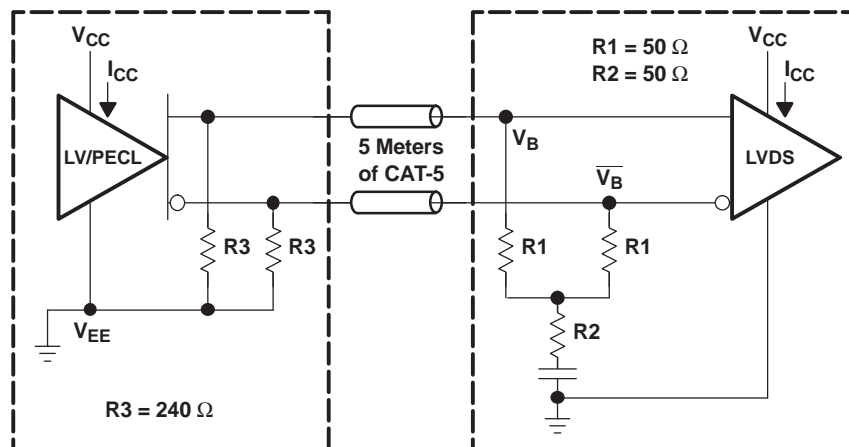

Figure 15. LVPECL or PECL to Remote Wide Common-Mode LVDS Receiver

PACKAGING INFORMATION

Orderable Device	Status (1)	Package Type	Package Drawing	Pins	Package Qty	Eco Plan (2)	Lead/Ball Finish	MSL Peak Temp (3)	Op Temp (°C)	Top-Side Markings (4)	Samples
SN65LVDS349PW	ACTIVE	TSSOP	PW	16	90	Green (RoHS & no Sb/Br)	CU NIPDAU	Level-1-260C-UNLIM	-40 to 85	DL349	Samples
SN65LVDS349PWR	ACTIVE	TSSOP	PW	16	2000	Green (RoHS & no Sb/Br)	CU NIPDAU	Level-1-260C-UNLIM	-40 to 85	DL349	Samples

(1) The marketing status values are defined as follows:

ACTIVE: Product device recommended for new designs.

LIFEBUY: TI has announced that the device will be discontinued, and a lifetime-buy period is in effect.

NRND: Not recommended for new designs. Device is in production to support existing customers, but TI does not recommend using this part in a new design.

PREVIEW: Device has been announced but is not in production. Samples may or may not be available.

OBSOLETE: TI has discontinued the production of the device.

(2) Eco Plan - The planned eco-friendly classification: Pb-Free (RoHS), Pb-Free (RoHS Exempt), or Green (RoHS & no Sb/Br) - please check <http://www.ti.com/productcontent> for the latest availability information and additional product content details.

TBD: The Pb-Free/Green conversion plan has not been defined.

Pb-Free (RoHS): TI's terms "Lead-Free" or "Pb-Free" mean semiconductor products that are compatible with the current RoHS requirements for all 6 substances, including the requirement that lead not exceed 0.1% by weight in homogeneous materials. Where designed to be soldered at high temperatures, TI Pb-Free products are suitable for use in specified lead-free processes.

Pb-Free (RoHS Exempt): This component has a RoHS exemption for either 1) lead-based flip-chip solder bumps used between the die and package, or 2) lead-based die adhesive used between the die and leadframe. The component is otherwise considered Pb-Free (RoHS compatible) as defined above.

Green (RoHS & no Sb/Br): TI defines "Green" to mean Pb-Free (RoHS compatible), and free of Bromine (Br) and Antimony (Sb) based flame retardants (Br or Sb do not exceed 0.1% by weight in homogeneous material)

(3) MSL, Peak Temp. -- The Moisture Sensitivity Level rating according to the JEDEC industry standard classifications, and peak solder temperature.

(4) Multiple Top-Side Markings will be inside parentheses. Only one Top-Side Marking contained in parentheses and separated by a "~" will appear on a device. If a line is indented then it is a continuation of the previous line and the two combined represent the entire Top-Side Marking for that device.

Important Information and Disclaimer: The information provided on this page represents TI's knowledge and belief as of the date that it is provided. TI bases its knowledge and belief on information provided by third parties, and makes no representation or warranty as to the accuracy of such information. Efforts are underway to better integrate information from third parties. TI has taken and continues to take reasonable steps to provide representative and accurate information but may not have conducted destructive testing or chemical analysis on incoming materials and chemicals. TI and TI suppliers consider certain information to be proprietary, and thus CAS numbers and other limited information may not be available for release.

In no event shall TI's liability arising out of such information exceed the total purchase price of the TI part(s) at issue in this document sold by TI to Customer on an annual basis.

TAPE AND REEL INFORMATION

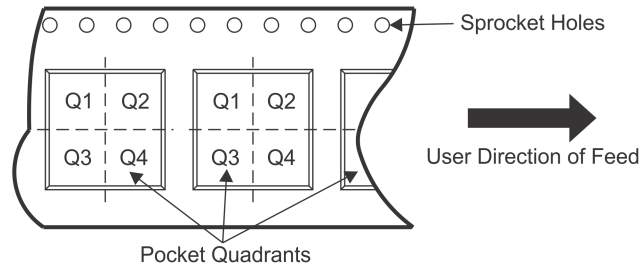
QUADRANT ASSIGNMENTS FOR PIN 1 ORIENTATION IN TAPE

*All dimensions are nominal

Device	Package Type	Package Drawing	Pins	SPQ	Reel Diameter (mm)	Reel Width W1 (mm)	A0 (mm)	B0 (mm)	K0 (mm)	P1 (mm)	W (mm)	Pin1 Quadrant
SN65LVDS349PWR	TSSOP	PW	16	2000	330.0	12.4	6.9	5.6	1.6	8.0	12.0	Q1

TAPE AND REEL BOX DIMENSIONS



*All dimensions are nominal

Device	Package Type	Package Drawing	Pins	SPQ	Length (mm)	Width (mm)	Height (mm)
SN65LVDS349PWR	TSSOP	PW	16	2000	350.0	350.0	43.0



4220204/A 02/2017

NOTES:

1. All linear dimensions are in millimeters. Any dimensions in parenthesis are for reference only. Dimensioning and tolerancing per ASME Y14.5M.
2. This drawing is subject to change without notice.
3. This dimension does not include mold flash, protrusions, or gate burrs. Mold flash, protrusions, or gate burrs shall not exceed 0.15 mm per side.
4. This dimension does not include interlead flash. Interlead flash shall not exceed 0.25 mm per side.
5. Reference JEDEC registration MO-153.

EXAMPLE BOARD LAYOUT

PW0016A

TSSOP - 1.2 mm max height

SMALL OUTLINE PACKAGE



LAND PATTERN EXAMPLE
EXPOSED METAL SHOWN
SCALE: 10X



SOLDER MASK DETAILS

4220204/A 02/2017

NOTES: (continued)

- 6. Publication IPC-7351 may have alternate designs.
- 7. Solder mask tolerances between and around signal pads can vary based on board fabrication site.

EXAMPLE STENCIL DESIGN

PW0016A

TSSOP - 1.2 mm max height

SMALL OUTLINE PACKAGE



SOLDER PASTE EXAMPLE
BASED ON 0.125 mm THICK STENCIL
SCALE: 10X

4220204/A 02/2017

NOTES: (continued)

8. Laser cutting apertures with trapezoidal walls and rounded corners may offer better paste release. IPC-7525 may have alternate design recommendations.
9. Board assembly site may have different recommendations for stencil design.

IMPORTANT NOTICE AND DISCLAIMER

TI PROVIDES TECHNICAL AND RELIABILITY DATA (INCLUDING DATASHEETS), DESIGN RESOURCES (INCLUDING REFERENCE DESIGNS), APPLICATION OR OTHER DESIGN ADVICE, WEB TOOLS, SAFETY INFORMATION, AND OTHER RESOURCES "AS IS" AND WITH ALL FAULTS, AND DISCLAIMS ALL WARRANTIES, EXPRESS AND IMPLIED, INCLUDING WITHOUT LIMITATION ANY IMPLIED WARRANTIES OF MERCHANTABILITY, FITNESS FOR A PARTICULAR PURPOSE OR NON-INFRINGEMENT OF THIRD PARTY INTELLECTUAL PROPERTY RIGHTS.

These resources are intended for skilled developers designing with TI products. You are solely responsible for (1) selecting the appropriate TI products for your application, (2) designing, validating and testing your application, and (3) ensuring your application meets applicable standards, and any other safety, security, or other requirements. These resources are subject to change without notice. TI grants you permission to use these resources only for development of an application that uses the TI products described in the resource. Other reproduction and display of these resources is prohibited. No license is granted to any other TI intellectual property right or to any third party intellectual property right. TI disclaims responsibility for, and you will fully indemnify TI and its representatives against, any claims, damages, costs, losses, and liabilities arising out of your use of these resources.

TI's products are provided subject to TI's Terms of Sale (www.ti.com/legal/termsofsale.html) or other applicable terms available either on ti.com or provided in conjunction with such TI products. TI's provision of these resources does not expand or otherwise alter TI's applicable warranties or warranty disclaimers for TI products.

Mailing Address: Texas Instruments, Post Office Box 655303, Dallas, Texas 75265
Copyright © 2019, Texas Instruments Incorporated

Looking for pricing, stock, or lifecycle information?

Click below to explore more details on WIN SOURCE:

 [View SN65LVDS349PW on WIN SOURCE](#)

 [Texas Instruments](#) Information

Optimize Your Supply Chain with WIN SOURCE Solutions

-  Global Sourcing Solution
-  Obsolete Management
-  Cost Control Management
-  Shortage Management
-  Alternative Solution
-  Excess Inventory Management