



**THE DATASHEET OF
UCC3889DTR**





Off-line Power Supply Controller

FEATURES

- Transformerless Off-line Applications
- Ideal Primary-side Bias Supply
- Efficient BiCMOS Design
- Wide Input Range
- Fixed or Adjustable Low Voltage Output
- Uses Low Cost SMD Inductors
- Short Circuit Protected
- Optional Isolation Capability

DESCRIPTION

The UCC1889 controller is optimized for use as an off-line, low power, low voltage, regulated bias supply. The unique circuit topology utilized in this device can be visualized as two cascaded flyback converters, each operating in the discontinuous mode, and both driven from a single external power switch. The significant benefit of this approach is the ability to achieve voltage conversion ratios of 400V to 12V with no transformer and low internal losses.

The control algorithm utilized by the UCC1889 is to force the switch on time to be inversely proportional to the input line voltage while the switch off time is made inversely proportional to the output voltage. This action is automatically controlled by an internal feedback loop and reference. The cascaded configuration allows a voltage conversion from 400V to 12V to be achieved with a switch duty cycle greater than 10%. This topology also offers inherent short circuit protection since as the output voltage falls to zero, the switch off time approaches infinity.

The output voltage can be easily set to 12V or 18V. Moreover, it can be programmed for other output voltages less than 18V with a few additional components. An isolated version can be achieved with this topology as described further in Unitrode Application Note U-149.

OPERATION

With reference to the application diagram below, when input voltage is first applied, the R_{ON} current into T_{ON} is directed to V_{CC} where it charges the external capacitor, C_3 , connected to V_{CC} . As voltage builds on V_{CC} , an internal undervoltage lockout holds the circuit off and the output at $DRIVE$ low until V_{CC} reaches 8.4V. At this time, $DRIVE$ goes high turning on the power switch, Q_1 , and redirecting the current into T_{ON} to the timing capacitor, C_T . C_T charges to a fixed threshold with a current $I_{CHG} = 0.8 \cdot (V_{IN} - 4.5V) / R_{ON}$. Since $DRIVE$ will only be high for as long as C_T charges, the power switch on time will be inversely proportional to line voltage. This provides a constant line voltage-switch on time product.

TYPICAL APPLICATION

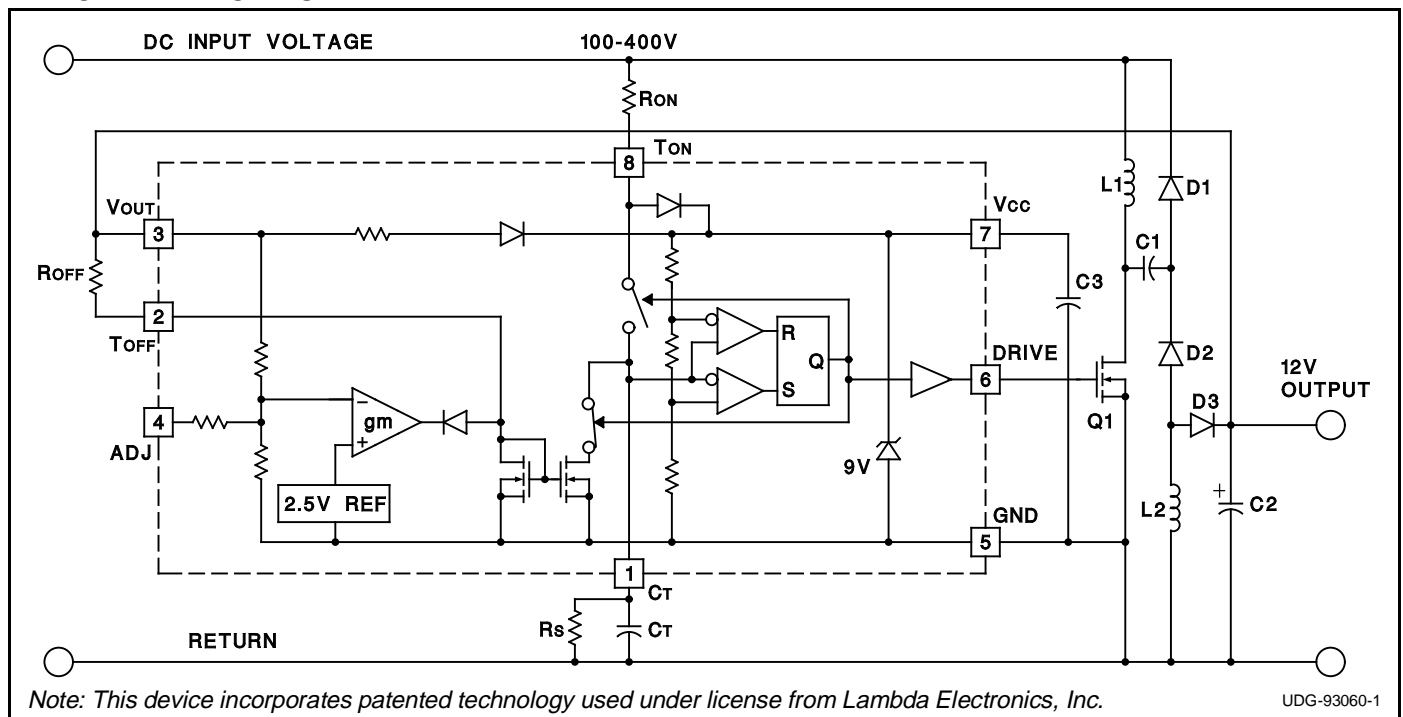

OPERATION (cont.)

At the end of the on time, Q1 is turned off and the RON current into TON is again diverted to VCC. Thus the current through RON, which charges CT during the on time, contributes to supplying control power during the off time.

The power switch off time is controlled by the discharge of CT which, in turn, is programmed by the regulated output voltage. The relationship between CT discharge current, IDCHG, and output voltage is illustrated as follows:

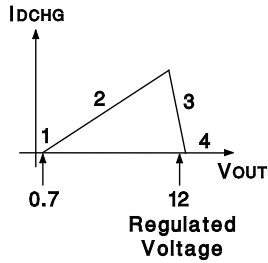

1. When VOUT = 0, the off time is infinite. This feature provides inherent short circuit protection. However, to ensure output voltage startup when the output is not a short, a high value resistor, Rs, is placed in parallel with CT to establish a minimum switching frequency.
2. As VOUT rises above approximately 0.7V to its regulated value, IDCHG is defined by ROFF, and therefore is equal to:

$$IDCHG = (VOUT - 0.7V) / ROFF$$

As VOUT increases, IDCHG increases resulting in the reduction of off time. The frequency of operation increases and VOUT rises quickly to its regulated value.

3. In this region, a transconductance amplifier reduces IDCHG in order to maintain VOUT in regulation.
4. If VOUT should rise above its regulation range, IDCHG falls to zero and the circuit returns to the minimum frequency established by Rs and CT.

The range of switching frequencies is established by RON, ROFF, Rs, and CT as follows:

$$\text{Frequency} = 1 / (TON + TOFF)$$

$$TON = RON \cdot CT \cdot 4.6 V / (VIN - 4.5V)$$

$$TOFF \text{ (max)} = 1.4 \cdot Rs \cdot CT$$

Regions 1 and 4

$$TOFF = ROFF \cdot CT \cdot 3.7V / (VOUT - 0.7V)$$

Region 2, excluding the effects of Rs which have a minimal impact on TOFF.

The above equations assume that VCC equals 9V. The voltage at TON increases from approximately 2.5V to 6.5V while CT is charging. To take this into account, VIN is adjusted by 4.5V in the calculation of TON. The voltage at TOFF is approximately 0.7V.

DESIGN EXAMPLE

The UCC3889 regulates a 12 volt, 1 Watt nonisolated DC output from AC inputs between 80 and 265 volts. In this example, the IC is programmed to deliver a maximum on time gate drive pulse width of 2.4 microseconds which occurs at 80 VAC. The corresponding switching frequency is approximately 100kHz at low line, and overall efficiency is approximately 50%. Additional design information is available in Unitrode Application Note U-149.

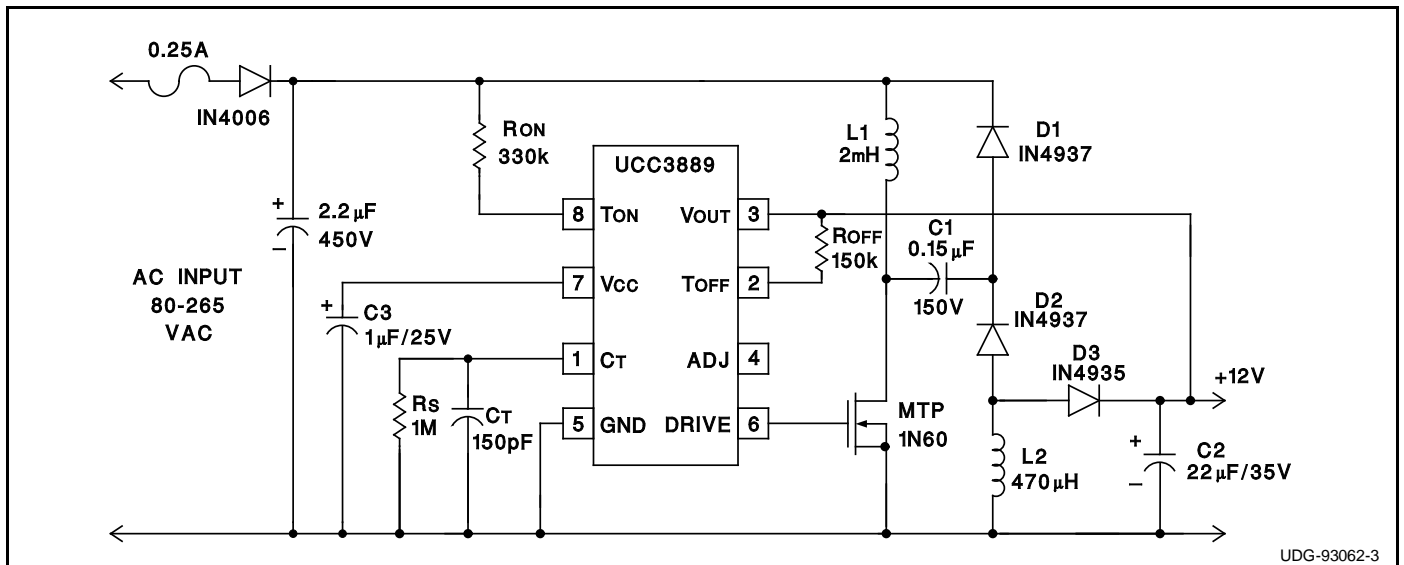

UDG-93062-3

ABSOLUTE MAXIMUM RATINGS

| | |
|---|-----------------|
| I _{CC} | 5mA |
| Current into T _{ON} Pin | 1.5mA |
| Voltage on V _{OUT} Pin | 20V |
| Current into T _{OFF} Pin | 250µA |
| Storage Temperature | -65°C to +150°C |

Note: Unless otherwise indicated, voltages are referenced to ground and currents are positive into, negative out of, the specified terminals.

CONNECTION DIAGRAM

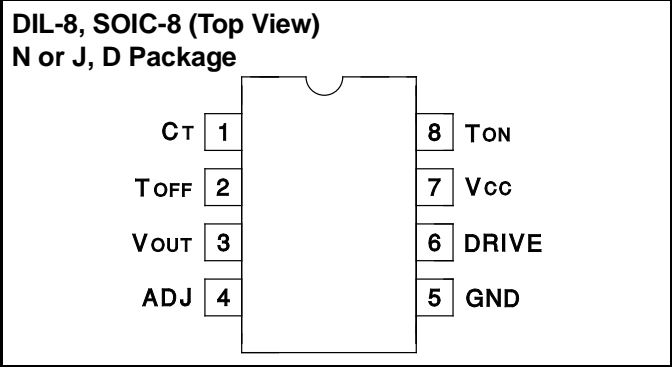

ELECTRICAL CHARACTERISTICS Unless otherwise stated, these specifications hold for T_A = 0°C to 70°C for the UCC3889, -40°C to +85°C for the UCC2889, and -55°C to +125°C for the UCC1889. No load at DRIVE pin (C_{LOAD}=0).

| PARAMETER | TEST CONDITIONS | MIN | TYP | MAX | UNITS |
|--|--|------|------|------|-------|
| General | | | | | |
| V _{CC} Zener Voltage | I _{CC} < 1.5mA | 8.6 | 9.0 | 9.3 | V |
| Startup Current | V _{OUT} = 0 | | 150 | 250 | µA |
| Operating Current I(V _{OUT}) | V _{OUT} = 11V, F = 150kHz | | 1.2 | 2.5 | mA |
| Under-Voltage-Lockout | | | | | |
| Start Threshold | V _{OUT} = 0 | 8.0 | 8.4 | 8.8 | V |
| Minimum Operating Voltage after Start | V _{OUT} = 0 | 6.0 | 6.3 | 6.6 | V |
| Hysteresis | V _{OUT} = 0 | 1.8 | | | V |
| Oscillator | | | | | |
| Amplitude | V _{CC} = 9V | 3.5 | 3.7 | 3.9 | V |
| C _T to DRIVE high Propagation Delay | Overdrive = 0.2V | | 100 | 200 | ns |
| C _T to DRIVE low Propagation Delay | Overdrive = 0.2V | | 50 | 100 | ns |
| Driver | | | | | |
| VOL | I = 20mA, V _{CC} = 9V | | 0.15 | 0.4 | V |
| | I = 100mA, V _{CC} = 9V | | 0.7 | 1.8 | V |
| VOH | I = -20mA, V _{CC} = 9V | 8.5 | 8.8 | | V |
| | I = -100mA, V _{CC} = 9V | 6.1 | 7.8 | | V |
| Rise Time | C _{LOAD} = 1nF | | 35 | 70 | ns |
| Fall Time | C _{LOAD} = 1nF | | 30 | 60 | ns |
| Line Voltage Detection | | | | | |
| Charge Coefficient: I _{CHG} / I(T _{ON}) | V _{CT} = 3V, DRIVE = High, I(T _{ON}) = 1mA | 0.73 | 0.79 | 0.85 | |
| Minimum Line Voltage for Fault | R _{ON} = 330k | 60 | 80 | 100 | V |
| Minimum Current I(T _{ON}) for Fault | R _{ON} = 330k | | 220 | | µA |
| On Time During Fault | C _T = 150pF, V _{LINE} = Min - 1V | | 2 | | µs |
| Oscillator Restart Delay after Fault | | | 0.5 | | ms |
| V_{OUT} Error Amp | | | | | |
| V _{OUT} Regulated 12V (ADJ Open) | V _{CC} = 9V, I _{DCHG} = I(T _{OFF})/2 | 11.2 | 11.9 | 12.8 | V |
| V _{OUT} Regulated 18V (ADJ = 0V) | V _{CC} = 9V, I _{DCHG} = I(T _{OFF})/2 | 16.5 | 17.5 | 19.5 | V |
| Discharge Ratio: I _{DCHG} / I(T _{OFF}) | I(T _{OFF}) = 50µA | 0.93 | 1.00 | 1.07 | |
| Voltage at T _{OFF} | I(T _{OFF}) = 50µA | 0.6 | 0.95 | 1.3 | V |
| Regulation gm (Note 1) | Max I _{DCHG} = 50µA | | 1.0 | | mA/V |
| | Max I _{DCHG} = 125µA | 0.8 | 1.7 | 2.9 | mA/V |

Note 1: gm is defined as $\frac{\Delta I_{DCHG}}{\Delta V_{OUT}}$ for the values of V_{OUT} when V_{OUT} is in regulation. The two points used to calculate gm are for I_{DCHG} at 65% and 35% of its maximum value.

PIN DESCRIPTIONS

ADJ: The ADJ pin is used to provide a 12V or an 18V regulated supply without additional external components. To select the 12V option, ADJ pin is left open. To select the 18V option, ADJ pin must be grounded. For other output voltages less than 18V, a resistor divider between VOUT, ADJ and GND is needed. Note, however, that for output voltages less than VCC, the device needs additional bootstrapping to VCC from an external source such as the line voltage. If so, precautions must be taken to ensure that total ICC does not exceed 5mA.

CT (timing capacitor): The signal voltage across CT has a peak-to-peak swing of 3.7V for 9V VCC. As the voltage on CT crosses the oscillator upper threshold, DRIVE goes low. As the voltage on CT crosses the oscillator lower threshold, DRIVE goes high.

DRIVE: This output is a CMOS stage capable of sinking 200mA peak and sourcing 150mA peak. The output voltage swing is 0 to VCC.

GND (chip ground): All voltages are measured with respect to GND.

TOFF (regulated output control): TOFF sets the discharge current of the timing capacitor through an external

resistor connected between VOUT and TOFF.

TON (line voltage control): TON serves three functions. When CT is discharging (off time), the current through TON is routed to VCC. When CT is charging (on time), the current through TON is split 80% to set the CT charge time and 20% to sense minimum line voltage which occurs for a TON current of 220µA. For a minimum line voltage of 80V, RON is 330kΩ.

The CT voltage slightly affects the value of the charge current during the on time. During this time, the voltage at the TON pin increases from approximately 2.5V to 6.5V.

VCC (chip supply voltage): The supply voltage of the device at pin VCC is internally clamped at 9V. Normally, VCC is not directly powered from an external voltage source such as the line voltage. In the event that VCC is directly connected to a voltage source for additional bootstrapping, precautions must be taken to ensure that total ICC does not exceed 5mA.

VOUT (regulated output): The VOUT pin is directly connected to the power supply output voltage. When VOUT is greater than VCC, VOUT bootstraps VCC.

BLOCK DIAGRAM

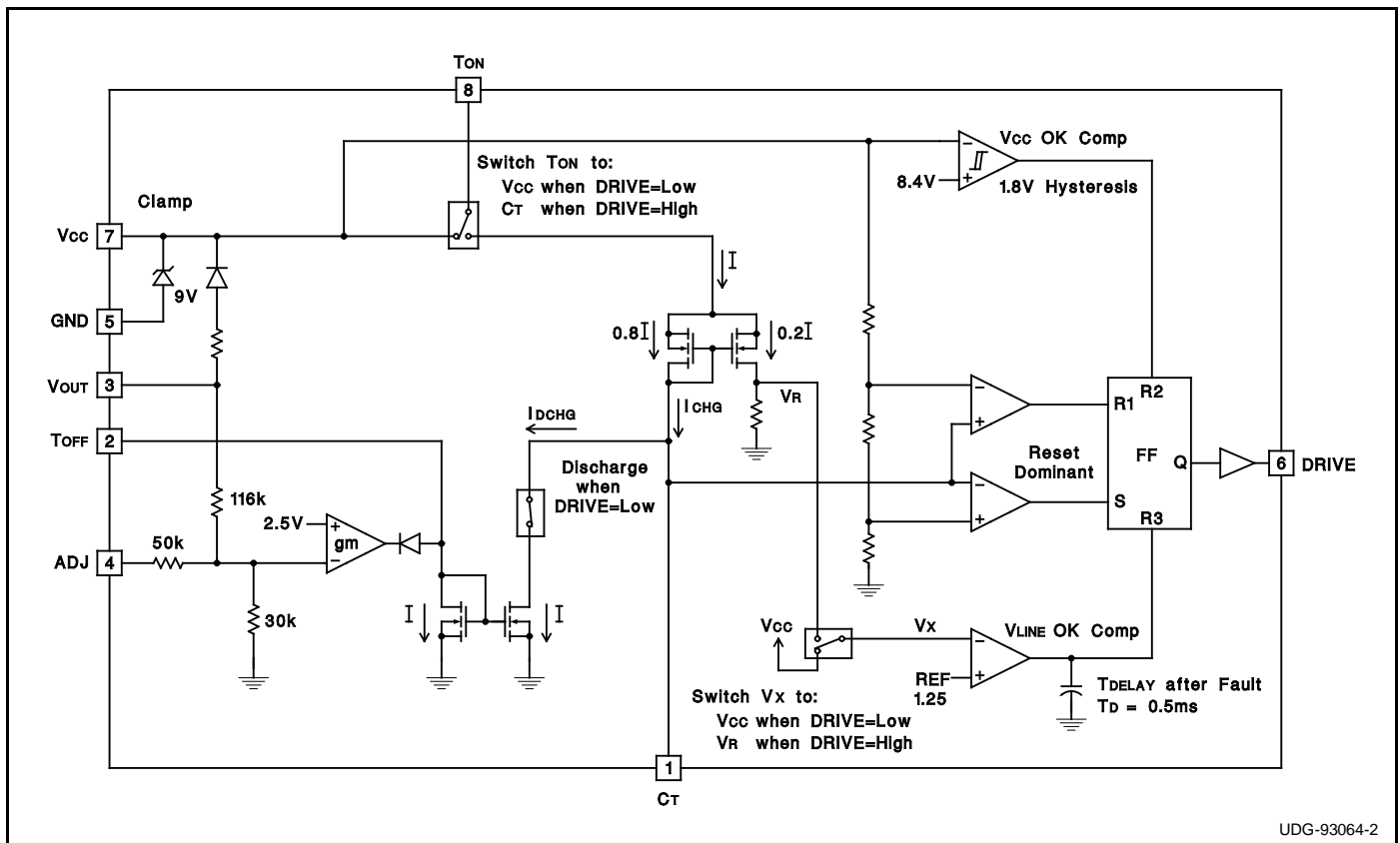

TYPICAL WAVEFORMS

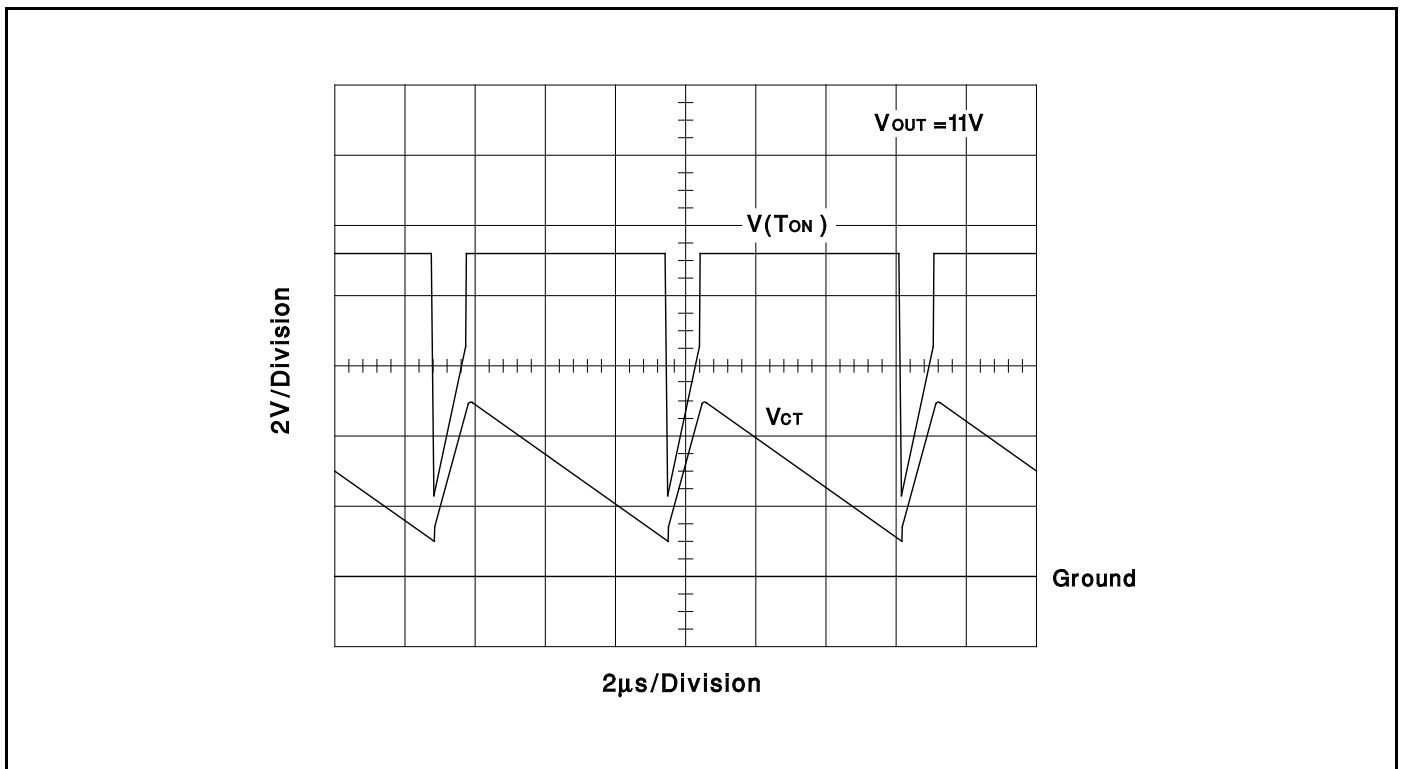
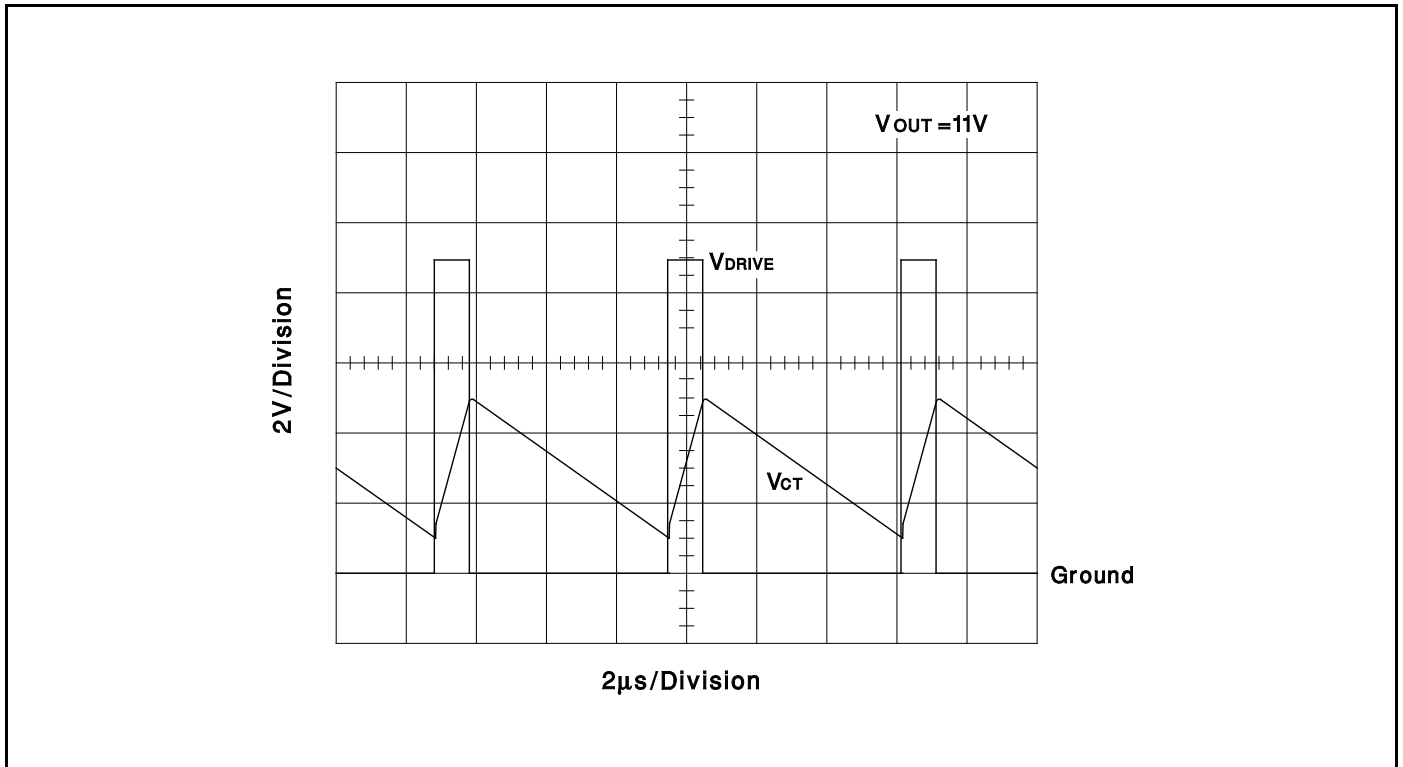

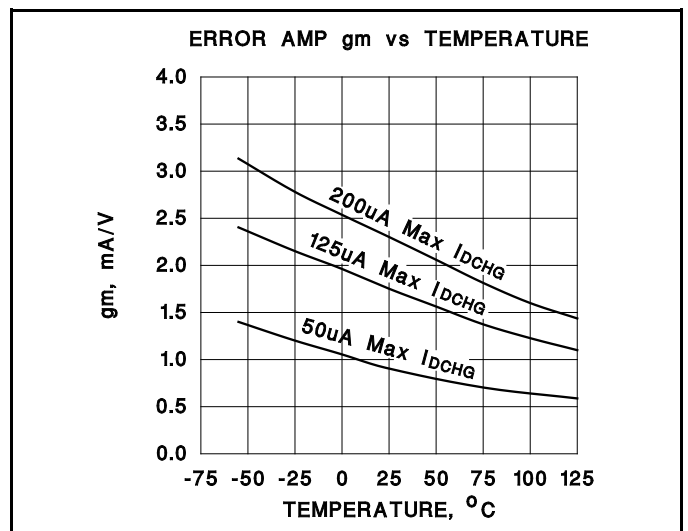
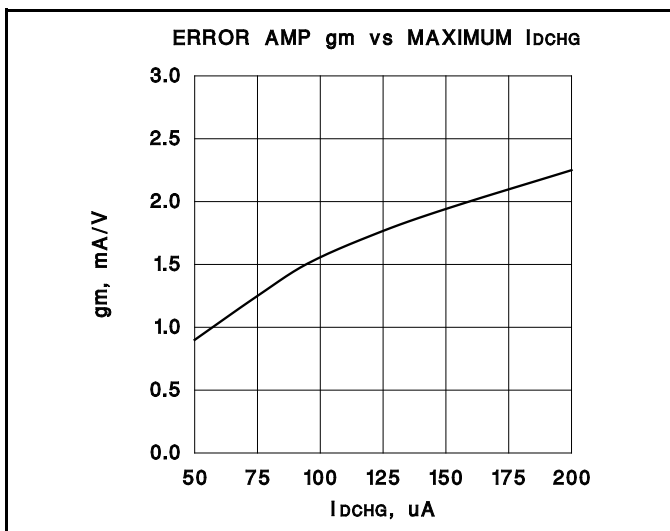
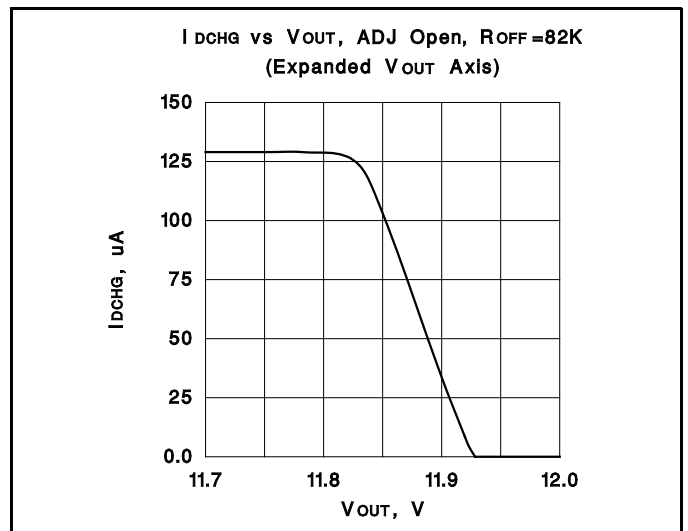
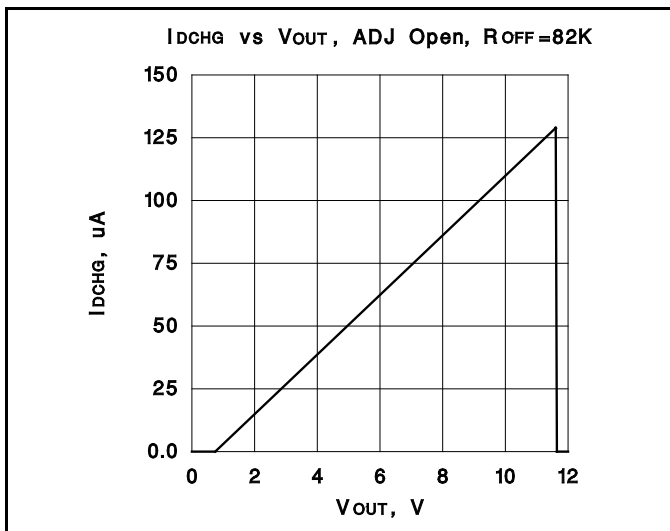
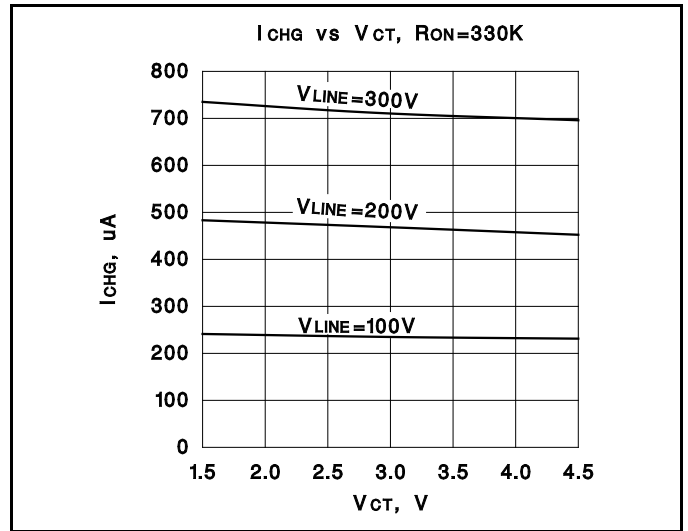
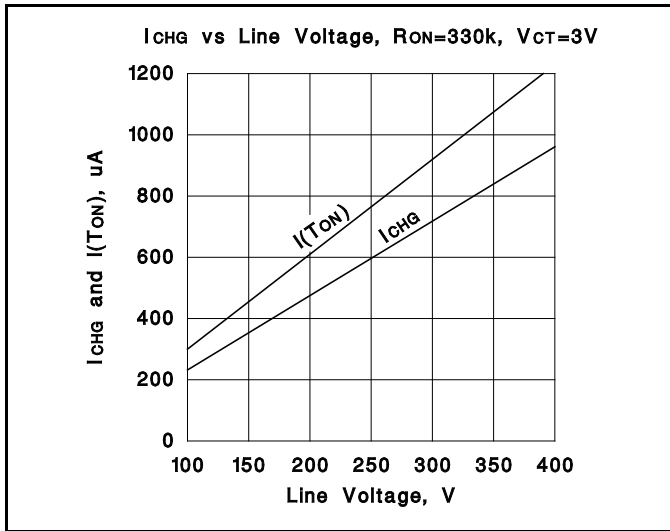

PACKAGING INFORMATION

| Orderable Device | Status (1) | Package Type | Package Drawing | Pins | Package Qty | Eco Plan (2) | Lead/Ball Finish (6) | MSL Peak Temp (3) | Op Temp (°C) | Device Marking (4/5) | Samples |
|------------------|---------------|--------------|-----------------|------|-------------|-------------------------|-------------------------|----------------------|--------------|-------------------------|-------------------------|
| UCC2889D | ACTIVE | SOIC | D | 8 | 75 | Green (RoHS & no Sb/Br) | CU NIPDAU | Level-2-260C-1 YEAR | -40 to 85 | UCC2889 | Samples |
| UCC2889DTR | ACTIVE | SOIC | D | 8 | 2500 | Green (RoHS & no Sb/Br) | CU NIPDAU | Level-2-260C-1 YEAR | -40 to 85 | UCC2889 | Samples |
| UCC2889DTRG4 | ACTIVE | SOIC | D | 8 | 2500 | Green (RoHS & no Sb/Br) | CU NIPDAU | Level-2-260C-1 YEAR | -40 to 85 | UCC2889 | Samples |
| UCC2889N | ACTIVE | PDIP | P | 8 | 50 | Green (RoHS & no Sb/Br) | CU NIPDAU | N / A for Pkg Type | -40 to 85 | UCC2889N | Samples |
| UCC3889D | ACTIVE | SOIC | D | 8 | 75 | Green (RoHS & no Sb/Br) | CU NIPDAU | Level-2-260C-1 YEAR | 0 to 70 | UCC3889 | Samples |
| UCC3889DG4 | ACTIVE | SOIC | D | 8 | 75 | Green (RoHS & no Sb/Br) | CU NIPDAU | Level-2-260C-1 YEAR | 0 to 70 | UCC3889 | Samples |
| UCC3889DTR | ACTIVE | SOIC | D | 8 | 2500 | Green (RoHS & no Sb/Br) | CU NIPDAU | Level-2-260C-1 YEAR | 0 to 70 | UCC3889 | Samples |
| UCC3889N | ACTIVE | PDIP | P | 8 | 50 | Green (RoHS & no Sb/Br) | CU NIPDAU | N / A for Pkg Type | 0 to 70 | UCC3889N | Samples |

(1) The marketing status values are defined as follows:

ACTIVE: Product device recommended for new designs.

LIFEBUY: TI has announced that the device will be discontinued, and a lifetime-buy period is in effect.

NRND: Not recommended for new designs. Device is in production to support existing customers, but TI does not recommend using this part in a new design.

PREVIEW: Device has been announced but is not in production. Samples may or may not be available.

OBsolete: TI has discontinued the production of the device.

(2) **RoHS:** TI defines "RoHS" to mean semiconductor products that are compliant with the current EU RoHS requirements for all 10 RoHS substances, including the requirement that RoHS substance do not exceed 0.1% by weight in homogeneous materials. Where designed to be soldered at high temperatures, "RoHS" products are suitable for use in specified lead-free processes. TI may reference these types of products as "Pb-Free".

RoHS Exempt: TI defines "RoHS Exempt" to mean products that contain lead but are compliant with EU RoHS pursuant to a specific EU RoHS exemption.

Green: TI defines "Green" to mean the content of Chlorine (Cl) and Bromine (Br) based flame retardants meet JS709B low halogen requirements of <=100ppm threshold. Antimony trioxide based flame retardants must also meet the <=1000ppm threshold requirement.

(3) MSL, Peak Temp. - The Moisture Sensitivity Level rating according to the JEDEC industry standard classifications, and peak solder temperature.

(4) There may be additional marking, which relates to the logo, the lot trace code information, or the environmental category on the device.

⁽⁵⁾ Multiple Device Markings will be inside parentheses. Only one Device Marking contained in parentheses and separated by a "-" will appear on a device. If a line is indented then it is a continuation of the previous line and the two combined represent the entire Device Marking for that device.

⁽⁶⁾ Lead/Ball Finish - Orderable Devices may have multiple material finish options. Finish options are separated by a vertical ruled line. Lead/Ball Finish values may wrap to two lines if the finish value exceeds the maximum column width.

Important Information and Disclaimer:The information provided on this page represents TI's knowledge and belief as of the date that it is provided. TI bases its knowledge and belief on information provided by third parties, and makes no representation or warranty as to the accuracy of such information. Efforts are underway to better integrate information from third parties. TI has taken and continues to take reasonable steps to provide representative and accurate information but may not have conducted destructive testing or chemical analysis on incoming materials and chemicals. TI and TI suppliers consider certain information to be proprietary, and thus CAS numbers and other limited information may not be available for release.

In no event shall TI's liability arising out of such information exceed the total purchase price of the TI part(s) at issue in this document sold by TI to Customer on an annual basis.

TAPE AND REEL INFORMATION

QUADRANT ASSIGNMENTS FOR PIN 1 ORIENTATION IN TAPE

*All dimensions are nominal

| Device | Package Type | Package Drawing | Pins | SPQ | Reel Diameter (mm) | Reel Width W1 (mm) | A0 (mm) | B0 (mm) | K0 (mm) | P1 (mm) | W (mm) | Pin1 Quadrant |
|------------|--------------|-----------------|------|------|--------------------|--------------------|---------|---------|---------|---------|--------|---------------|
| UCC2889DTR | SOIC | D | 8 | 2500 | 330.0 | 12.4 | 6.4 | 5.2 | 2.1 | 8.0 | 12.0 | Q1 |
| UCC3889DTR | SOIC | D | 8 | 2500 | 330.0 | 12.4 | 6.4 | 5.2 | 2.1 | 8.0 | 12.0 | Q1 |

TAPE AND REEL BOX DIMENSIONS

*All dimensions are nominal

| Device | Package Type | Package Drawing | Pins | SPQ | Length (mm) | Width (mm) | Height (mm) |
|------------|--------------|-----------------|------|------|-------------|------------|-------------|
| UCC2889DTR | SOIC | D | 8 | 2500 | 367.0 | 367.0 | 35.0 |
| UCC3889DTR | SOIC | D | 8 | 2500 | 367.0 | 367.0 | 35.0 |



D0008A

PACKAGE OUTLINE

SOIC - 1.75 mm max height

SMALL OUTLINE INTEGRATED CIRCUIT

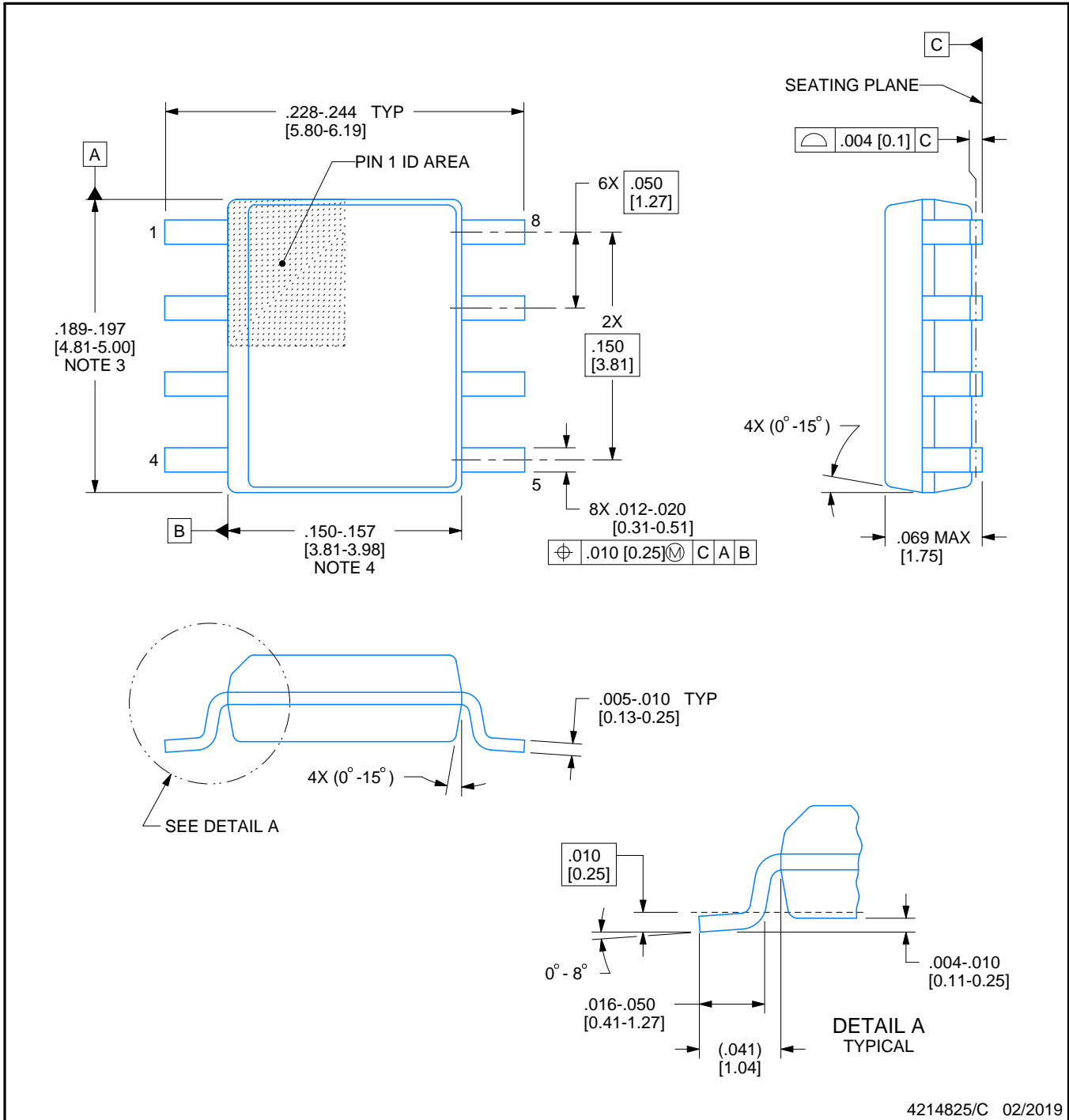

4214825/C 02/2019

NOTES:

- Linear dimensions are in inches [millimeters]. Dimensions in parenthesis are for reference only. Controlling dimensions are in inches. Dimensioning and tolerancing per ASME Y14.5M.
- This drawing is subject to change without notice.
- This dimension does not include mold flash, protrusions, or gate burrs. Mold flash, protrusions, or gate burrs shall not exceed $.006$ [0.15] per side.
- This dimension does not include interlead flash.
- Reference JEDEC registration MS-012, variation AA.

EXAMPLE BOARD LAYOUT

D0008A

SOIC - 1.75 mm max height

SMALL OUTLINE INTEGRATED CIRCUIT



LAND PATTERN EXAMPLE
 EXPOSED METAL SHOWN
 SCALE:8X



SOLDER MASK DETAILS

4214825/C 02/2019

NOTES: (continued)

- 6. Publication IPC-7351 may have alternate designs.
- 7. Solder mask tolerances between and around signal pads can vary based on board fabrication site.

EXAMPLE STENCIL DESIGN

D0008A

SOIC - 1.75 mm max height

SMALL OUTLINE INTEGRATED CIRCUIT



SOLDER PASTE EXAMPLE
BASED ON .005 INCH [0.125 MM] THICK STENCIL
SCALE:8X

4214825/C 02/2019

NOTES: (continued)

8. Laser cutting apertures with trapezoidal walls and rounded corners may offer better paste release. IPC-7525 may have alternate design recommendations.
9. Board assembly site may have different recommendations for stencil design.

P (R-PDIP-T8)

PLASTIC DUAL-IN-LINE PACKAGE

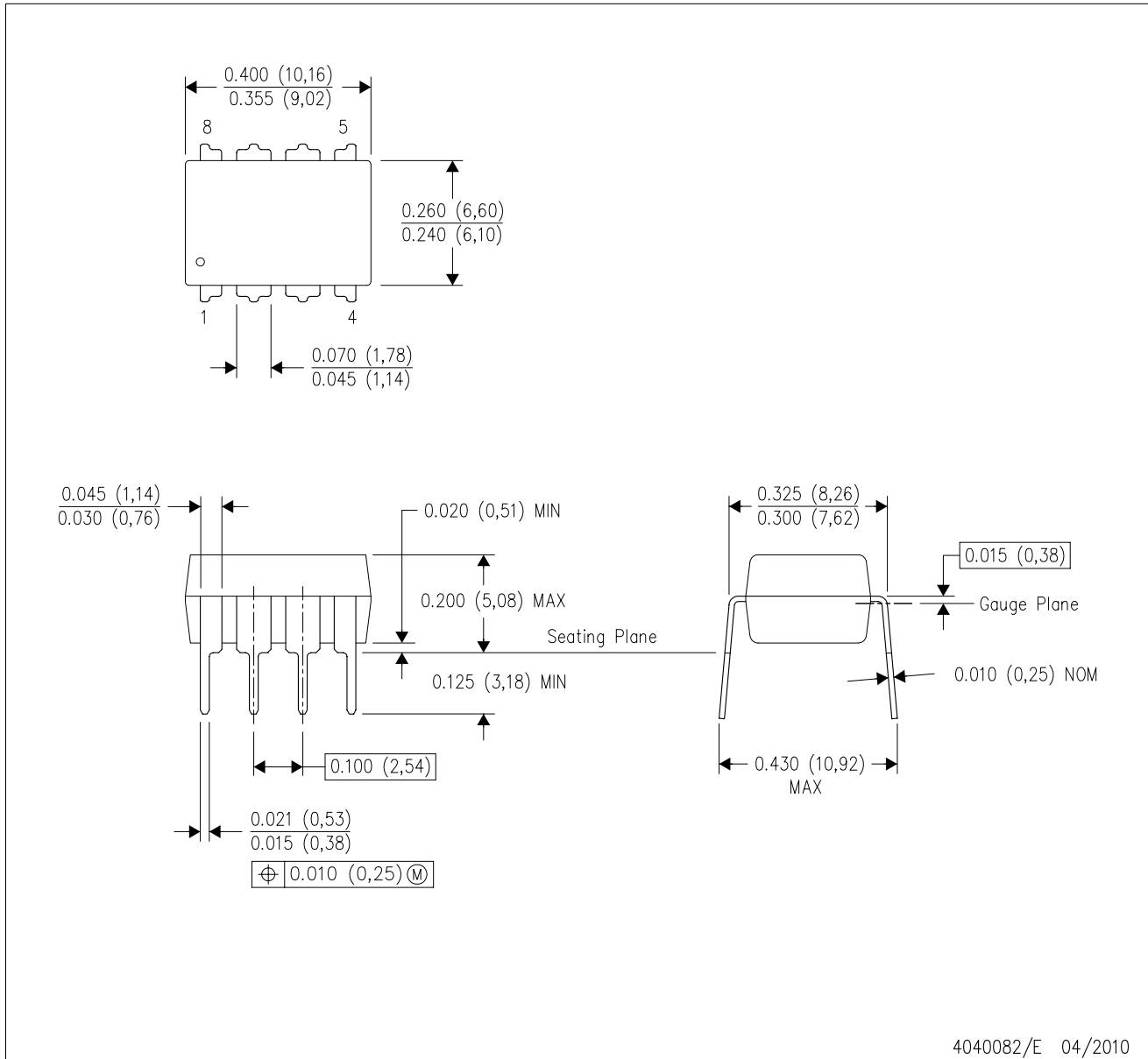

- NOTES:
- A. All linear dimensions are in inches (millimeters).
 - B. This drawing is subject to change without notice.
 - C. Falls within JEDEC MS-001 variation BA.

IMPORTANT NOTICE AND DISCLAIMER

TI PROVIDES TECHNICAL AND RELIABILITY DATA (INCLUDING DATASHEETS), DESIGN RESOURCES (INCLUDING REFERENCE DESIGNS), APPLICATION OR OTHER DESIGN ADVICE, WEB TOOLS, SAFETY INFORMATION, AND OTHER RESOURCES "AS IS" AND WITH ALL FAULTS, AND DISCLAIMS ALL WARRANTIES, EXPRESS AND IMPLIED, INCLUDING WITHOUT LIMITATION ANY IMPLIED WARRANTIES OF MERCHANTABILITY, FITNESS FOR A PARTICULAR PURPOSE OR NON-INFRINGEMENT OF THIRD PARTY INTELLECTUAL PROPERTY RIGHTS.

These resources are intended for skilled developers designing with TI products. You are solely responsible for (1) selecting the appropriate TI products for your application, (2) designing, validating and testing your application, and (3) ensuring your application meets applicable standards, and any other safety, security, or other requirements. These resources are subject to change without notice. TI grants you permission to use these resources only for development of an application that uses the TI products described in the resource. Other reproduction and display of these resources is prohibited. No license is granted to any other TI intellectual property right or to any third party intellectual property right. TI disclaims responsibility for, and you will fully indemnify TI and its representatives against, any claims, damages, costs, losses, and liabilities arising out of your use of these resources.

TI's products are provided subject to TI's Terms of Sale (www.ti.com/legal/termsofsale.html) or other applicable terms available either on ti.com or provided in conjunction with such TI products. TI's provision of these resources does not expand or otherwise alter TI's applicable warranties or warranty disclaimers for TI products.

Mailing Address: Texas Instruments, Post Office Box 655303, Dallas, Texas 75265
Copyright © 2019, Texas Instruments Incorporated

Looking for pricing, stock, or lifecycle information?

Click below to explore more details on WIN SOURCE:

 [View UCC3889DTR](#) on WIN SOURCE

 [Texas Instruments](#) Information

Optimize Your Supply Chain with WIN SOURCE Solutions

-  Global Sourcing Solution
-  Obsolete Management
-  Cost Control Management
-  Shortage Management
-  Alternative Solution
-  Excess Inventory Management