



**THE DATASHEET OF  
LM9074M/NOPB**



# LM9074

*LM9074 System Voltage Regulator with Keep-Alive ON/OFF Control*



Literature Number: SNVS078E

# LM9074

## System Voltage Regulator with Keep-Alive ON/OFF Control

### General Description

The LM9074 is a 5V, 3% accurate, 180 mA NPN voltage regulator. The regulator features an active low delayed reset output flag which can be used to reset a microprocessor system on turn-ON and in the event that the regulator output falls out of regulation for any reason. An external capacitor programs a delay time interval before the reset output can return high.

Designed for automotive application the LM9074 contains a variety of protection features such as reverse battery, over-voltage shutdown, thermal shutdown, input transient protection and a wide operating temperature range.

A unique two-input logic control scheme is used to enable or disable the regulator output. An ON/OFF input can be provided by an ignition switch derived signal while a second, Keep-Alive input, is generated by a system controller. This allows for a system to remain ON after ignition has been switched OFF. The system controller can then execute a power-down routine and after which command the regulator OFF to a low quiescent current state (60  $\mu$ A max).

Design techniques have been employed to allow the regulator to remain operational and not generate false reset signals when subjected to high levels of RF energy (300V/m from 2 MHz to 400 MHz).

### Features

- Automotive application reliability
- 3% output voltage tolerance
- Insensitive to radiated RFI
- Dropout voltage less than 2.5V with 180mA output current
- Externally programmed reset delay interval
- Keep-alive feature with 2 logic control inputs
- +40V Load dump transient protection
- Thermal shutdown
- Short circuit protection and disable safety features
- Reverse battery protection
- Low OFF quiescent current, 60 $\mu$ A maximum
- Wide operating temperature range  $-40^{\circ}\text{C}$  to  $+125^{\circ}\text{C}$

### Connection Diagram and Ordering Information (Top View)

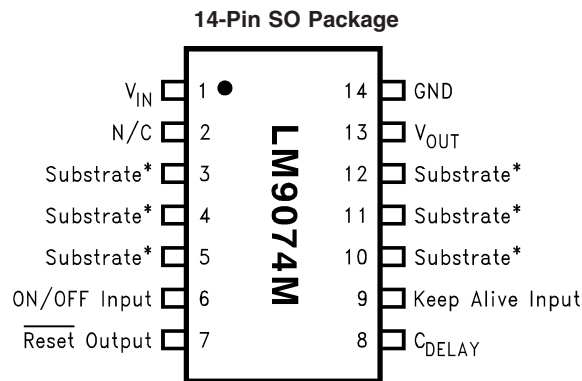

\* Substrate pins must be connected to Ground Pin

10130502

**Order Number LM9074M**  
**See NS Package Number M14A**

**Absolute Maximum Ratings** (Note 1)

Input Voltage	
ON/OFF, Keep-Alive Inputs (through 1 k $\Omega$ )	
DC Input Voltage	-26V to +26V
Positive Input Transient (t<100 ms)	40V
Negative Input Transient (t<1 ms)	-50V
Reset Output Sink Current	5 mA
Power Dissipation	Internally Limited
Junction Temperature	150°C
ESD Susceptibility (Note 2)	12 kV, 2 kV

Lead Temperature (Soldering, 10 seconds)	260°C
Storage Temperature	-50°C to +150°C

**Operating Ratings** (Note 1)

Input Voltage	7.5V to 16.5V
Ambient Temperature	-40°C to +125°C
$\theta_{ja}$ , M14A Package	88°C/W
$\theta_{jc}$ , M14A Package	34°C/W

**Electrical Characteristics**

The following specifications apply for  $V_{CC} = 7.5V$  to  $16.5V$ ,  $-40^\circ C \leq T_A \leq 125^\circ C$ , unless otherwise specified.  $C_{OUT} = 0.1\mu F$ .

Symbol	Parameter	Conditions	Min	Max	Units
<b>REGULATOR OUTPUT</b>					
$V_{OUT}$	Output Voltage	$20\text{ mA} \leq I_{OUT} \leq 180\text{ mA}$	4.85	5.15	V
$\Delta V_{OUT}$ Line	Line Regulation	$I_{OUT} = 20\text{ mA}$ , $9V \leq V_{IN} \leq 16.5V$ $I_{OUT} = 20\text{ mA}$ , $7.5V \leq V_{IN} \leq 16.5V$		25 50	mV mV
$\Delta V_{OUT}$ Load	Load Regulation	$V_{IN} = 14.4V$ , $20\text{ mA} \leq I_{OUT} \leq 180\text{ mA}$		50	mV
$I_q$	Quiescent Current	$4V \leq V_{ON/OFF} \leq V_{IN}$ $20\text{ mA} \leq I_{OUT} \leq 180\text{ mA}$		25	mA
$I_{off}$	OFF Quiescent Current	$V_{IN} \leq 16.5V$ , Regulator OFF $-40^\circ C \leq T_J \leq 60^\circ C$ $60^\circ C \leq T_J \leq 135^\circ C$		20 60	$\mu A$ $\mu A$
$V_{do}$	Dropout Voltage	$I_{OUT} = 20\text{ mA}$ $I_{OUT} = 180\text{ mA}$		2.0 2.5	V V
$I_{sc}$	Short Circuit Current	$R_L = 1\Omega$	0.4	1.0	A
PSRR	Ripple Rejection	$V_{IN} = (14V_{DC}) + (1V_{RMS} @ 120\text{ Hz})$ $I_{OUT} = 50\text{ mA}$	60		dB
$V_{othOFF}$	Safety $V_{OUT}$ Latch-OFF Threshold	In Keep-Alive mode $V_{ON/OFF} = 0V$ , $V_{KA} = 0V$	4	4.5	V
$V_o$ Transient	$V_{OUT}$ during Transients	$V_{IN}$ Peak $\leq 40V$ , $R_L = 100\Omega$ , $\tau = 100\text{ ms}$		5.5	V
<b>RESET OUTPUT</b>					
$V_{th}$	Threshold Voltage	$\Delta V_{OUT}$ Required to Generate a Reset Output $4.85V \leq V_{OUT} \leq 5.15V$	-300	-500	mV
$V_{low}$	Reset Output Low Voltage	$I_{sink} = 1.6\text{ mA}$ , $V_{OUT} > 3.2V$ $1.4V \leq V_{OUT} \leq 3.2V$		0.4 0.8	V V
$V_{high}$	Reset Output High Voltage		$0.9 V_{OUT}$	$V_{OUT}$	V
$t_{delay}$	Delay Time	$C_{delay} = 0.1\mu F$	7	45	ms
$I_{delay}$	Charging Current for $C_{delay}$		-7	25	$\mu A$
$R_{pu}$	Internal Pull-up Resistance		12	80	k $\Omega$
<b>CONTROL LOGIC</b>					
$V_{KAlow}$	Low Input Threshold Voltage, Keep-Alive Input	$3.5V \leq V_{OUT} \leq 5.25V$	$0.3 V_{OUT}$	$0.5 V_{OUT}$	V
$V_{KAhigh}$	High Input Threshold Voltage, Keep-Alive Input	$3.5V \leq V_{OUT} \leq 5.25V$	$0.6 V_{OUT}$	$0.8 V_{OUT}$	V
$V_{ON/OFF low}$	Low Input Voltage, ON/OFF Input	$R_{series} = 1\text{ k}\Omega$	-2	2	V
$V_{ON/OFF high}$	High Input Voltage, ON/OFF Input	$R_{series} = 1\text{ k}\Omega$	4	$V_{IN}$	V

## Electrical Characteristics (Continued)

The following specifications apply for  $V_{CC}=7.5V$  to  $16.5V$ ,  $-40^{\circ}C \leq T_A \leq 125^{\circ}C$ , unless otherwise specified.  $C_{OUT}=0.1\mu F$ .

Symbol	Parameter	Conditions	Min	Max	Units
<b>CONTROL LOGIC</b>					
$I_{ON/OFF}$	Input Current, ON/OFF Input	$V_{ON/OFF} \leq 4V$ $4V < V_{ON/OFF} < 7V$ $V_{ON/OFF} \geq 7V$		330 670 10	$\mu A$ $\mu A$ mA
$R_{pu_{KA}}$	Internal Pull-up Resistance, Keep-Alive Input		20	100	k $\Omega$
$R_{pd_{ON/OFF}}$	Internal Pull-down Resistance ON/OFF Input		50	210	k $\Omega$

**Note 1: Absolute Maximum Ratings** indicate limits beyond which damage to the device may occur. **Operating Ratings** indicate conditions for which the device is intended to be functional, but do not guarantee specific performance limits. For guaranteed specifications and conditions, see the **Electrical Characteristics**.

**Note 2:** All pins will survive an ESD impulse of  $\pm 2000V$  using the human body model of 100 pF discharged through a 1.5 k $\Omega$  resistor. In addition, input pins  $V_{IN}$  and the ON/OFF input will withstand ten pulses of  $\pm 12 kV$  from a 150 pF capacitor discharged through a 560 $\Omega$  resistor with each pin bypassed with a 22 nF, 100V capacitor.

## Reset Operation and Protection Features

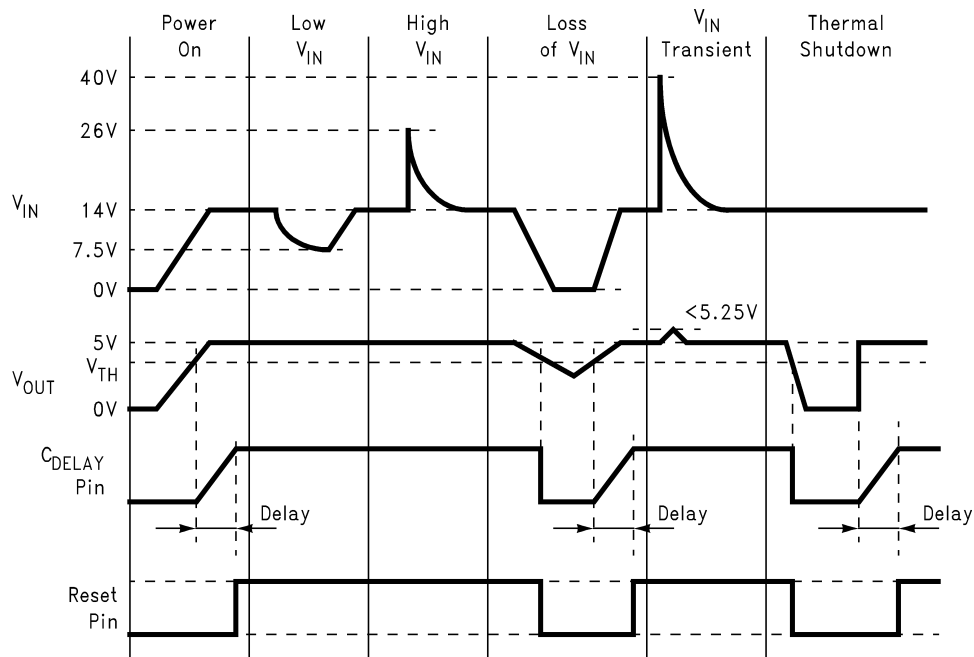

10130505

# Typical Performance Characteristics

( $T_A = 25^\circ\text{C}$  unless indicated otherwise)

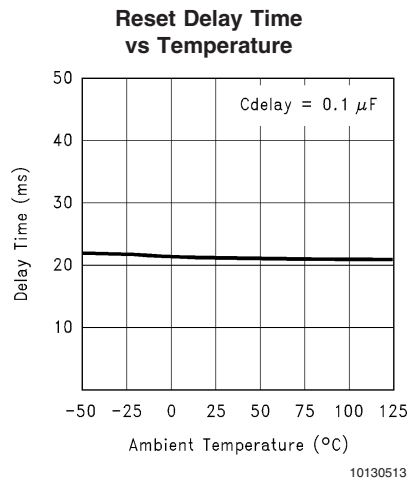
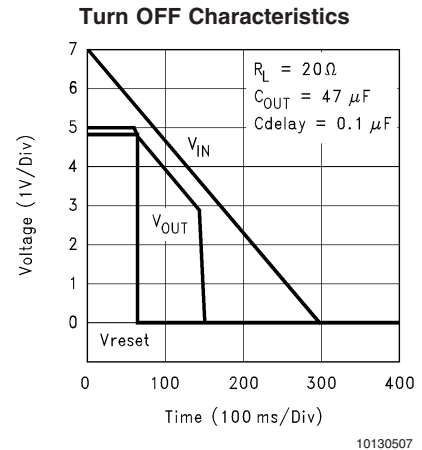
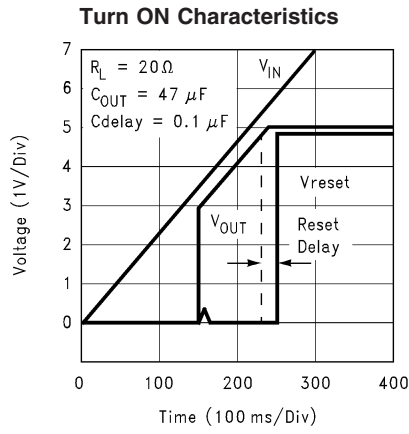

## ON/OFF, Keep-Alive and Safety Latch-Off Control Diagrams

**Note:** If Keep-Alive is provided by a microprocessor powered by the output voltage of the LM9074, the logic "1" voltage level will track  $V_{OUT}$  as the regulator turns OFF.

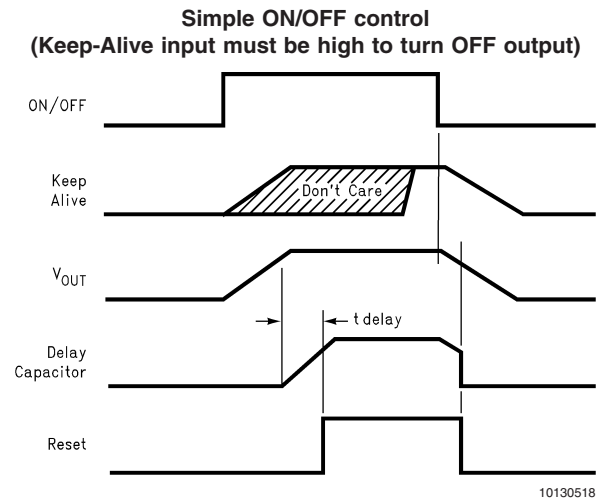

**Keep-Alive Mode; Turn ON with ON/OFF control, Keep output biased with Keep-Alive input, Turn OFF with Keep-Alive (Keep-Alive low keeps output ON, Keep-Alive going high turns output OFF)**

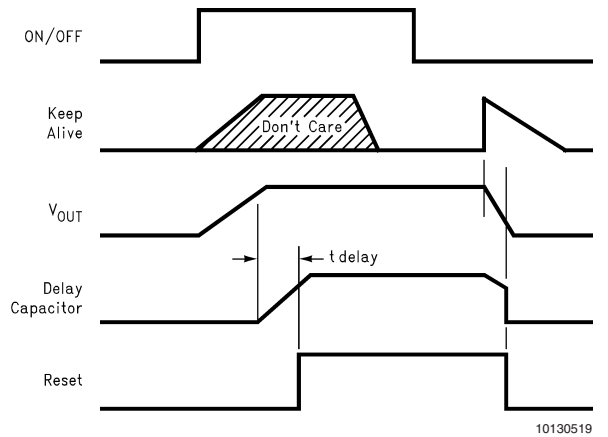

# ON/OFF, Keep-Alive and Safety Latch-Off Control Diagrams

(Continued)

Switch ON with ON/OFF input; Keep output biased with Keep-Alive; Hold output ON with ON/OFF; Turn OFF with ON/OFF input. (Temporary Keep-Alive Mode)

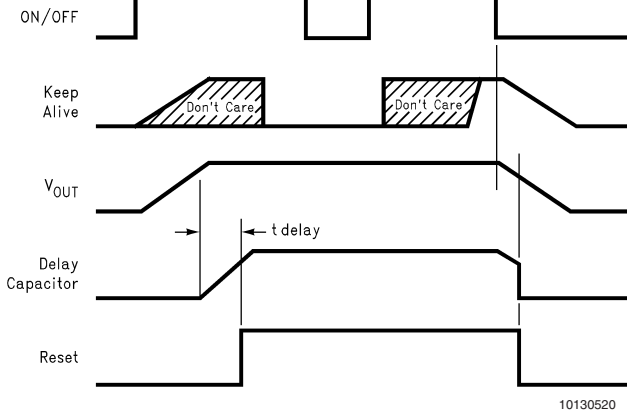

10130520

## Safety Latch OFF of V<sub>OUT</sub> when in Keep-Alive Mode (ON/OFF going high required to turn Output back ON)

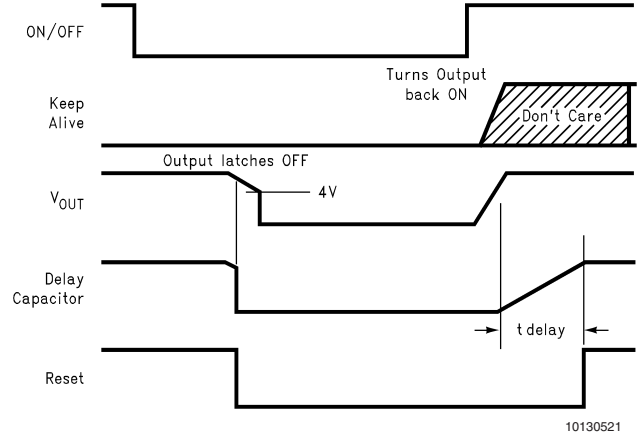

10130521

## Control Logic Truth Table

ON/OFF Input	Keep-Alive Input	Output Voltage	Reset Output	Operating Condition
L	X	0V	L	Low quiescent current standby (OFF) condition
↑	X	5V	↑ after delay	Output turns ON
H	X	5V	H	Normal ON condition
↓	H	0V	L	Output turns OFF
↓	L	5V	H	Output kept ON by Keep-Alive Input
↑	L	5V	H	Output remains ON (or turns ON)
H	X	$\Delta V_{OUT} \geq -300 \text{ mV}$	L	Output pulled out of regulation, reset flag generated
L	L	$V_{OUT} \leq 4V$	L	Output latches OFF

## Block Diagram

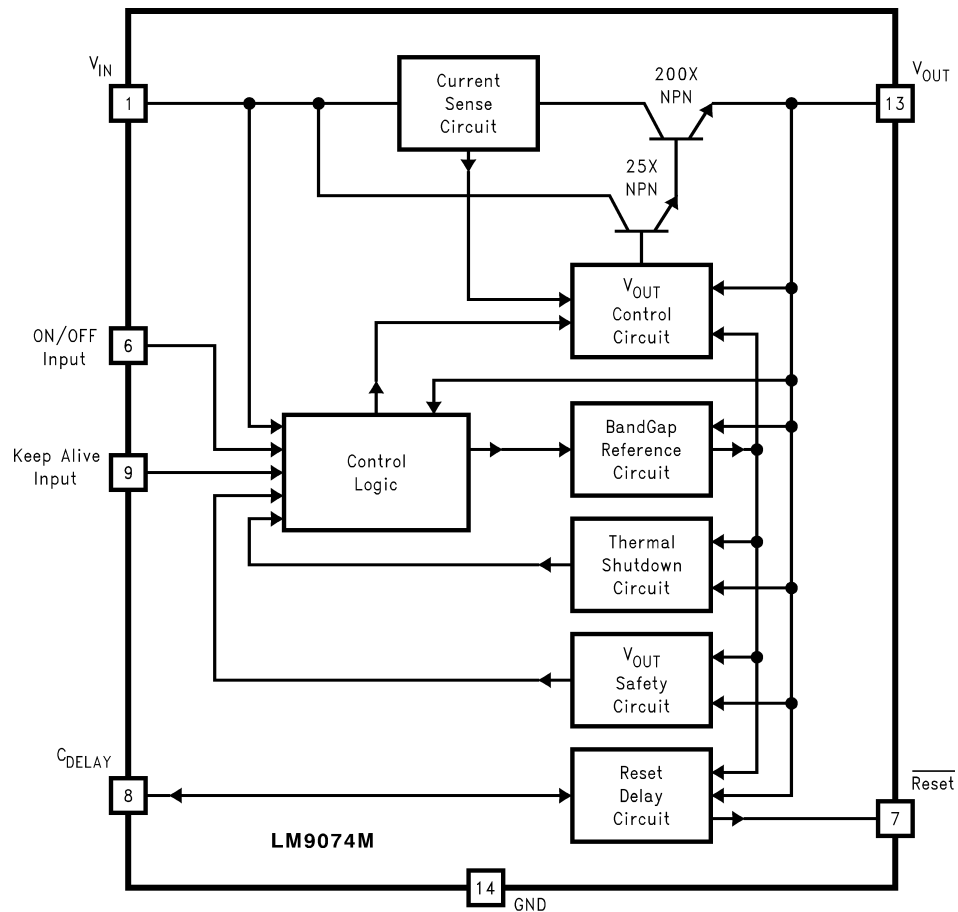

## Application Information

The LM9074 voltage regulator has been optimized for use in microprocessor based automotive systems. Several unique design features have been incorporated to address many FMEA (Failure Mode Effects Analysis) concerns for fail-safe system performance.

### FAULT TOLERANT FEATURES

While not specifically guaranteed due to production testing limitations, the LM9074 has been tested and shown to continue to provide a regulated output and, not generate an erroneous system reset signal while subjected to high levels of RF electric field energy (up to 300 V/m signal strength over a 2 MHz to 400 MHz frequency range). This is very important in vehicle safety related applications where the system must continue to operate normally. To maintain this

immunity to RFI the output bypass capacitor is important (47  $\mu$ F is recommended).

This regulator is suitable for applications where continuous connection to the battery is required (*Refer to the Typical Application Circuit*). ON/OFF control of the regulator and system can be accomplished by switching the ON/OFF input to the battery or ignition supply  $V_{IN}$  supply through a SPST switch. If this input becomes open circuited, an internal pull-down resistor ensures that the regulator turns OFF. When the regulator is switched OFF the current load on the battery drops to less than 60  $\mu$ A. With the possibility in many applications for  $V_{IN}$  and the ON/OFF input pins to be connected in a system through long lengths of wire, the ESD protection of these pins has been increased to 12 kV with the addition of small input bypass capacitors.

## Application Information (Continued)

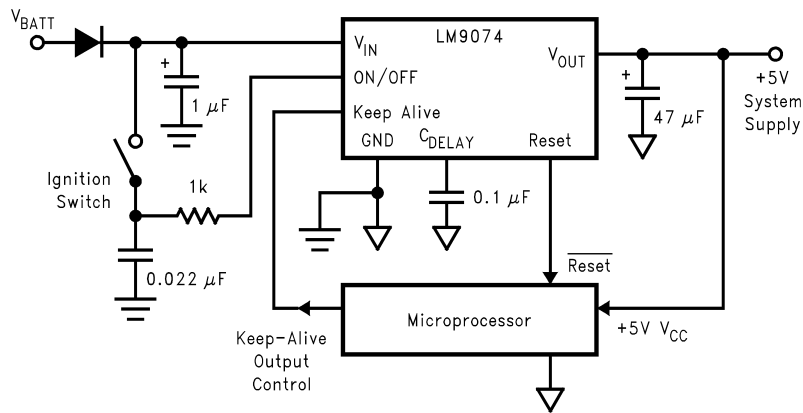

10130523

**FIGURE 1. Typical Application Circuit**

An output bypass capacitor of at least  $0.1\mu\text{F}$  is required for stability ( $47\mu\text{F}$  is recommended). An input capacitor of  $1\mu\text{F}$  or larger is recommended to improve line transient and noise performance.

With the Keep-Alive input, a system microprocessor has the ability to keep the regulator ON (with a logic “0” on Keep-Alive) after the ON/OFF input has been commanded OFF. A power-down sequence, when system variables are typically stored in programmable memory, can be executed and take as much time as necessary. At the end of the operation the micro then pulls Keep-Alive high and the regulator and system turn OFF and revert to the low quiescent current standby mode.

For additional system reliability, consideration has been made for the possibility of a short circuited load at the output

of the regulator. When the regulator is switched ON, conventional current limiting and thermal shutdown protect the regulator. When the regulator is switched OFF however, a grounded  $V_{CC}$  supply to the micro (due to the shorted regulator output) will force the Keep-Alive input to be low and thus try to maintain the Keep-Alive mode of operation. With a shorted load, the drain on the battery could be as high as 1.5A. A separate internal circuit monitors the output voltage of the regulator. If  $V_{OUT}$  is less than 4V, as would be the case with a shorted load, the Keep-Alive function is logically disabled to ensure that the regulator turns OFF and reverts to less than a  $60\mu\text{A}$  load on the battery.

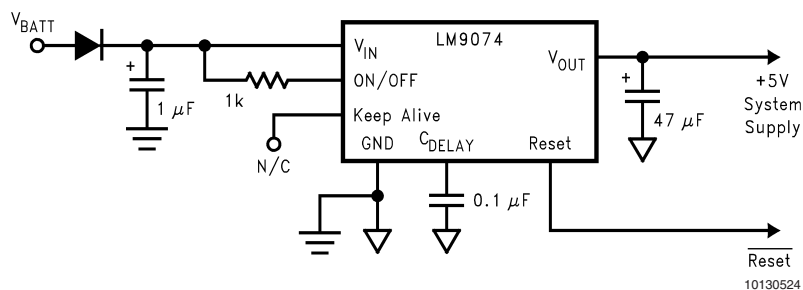

10130524

**FIGURE 2. Control Logic Not Used**

Conventional load dump protection is built in to withstand up to +60V and -50V transients. A  $1\text{ k}\Omega$  resistor in series with the ON/OFF and Keep-Alive inputs are recommended to provide the same level of transient protection for these pins if required. Protection against reverse polarity battery connections is also built in. With a reversed battery the output of the LM9074 will not go more negative than one diode drop below ground. This will prevent damage to any of the 5V load circuits.

For applications where the control logic is not required the logic pins should be configured as shown in Figure 2. A separate device, called the LM9071, can be used. The

LM9071 is available in a 5-lead TO-220 package and does not provide control logic functions, but still retains all of the protection features of the LM9074.

### RESET FLAG

Excessive loading of the output to the point where the output voltage drops by 300 mV to 500 mV will signal a reset flag to the micro. This will warn of a  $V_{CC}$  supply that may produce unpredictable operation of the system. On power-up and recovery from a fault condition the delay capacitor is used to

### Application Information (Continued)

hold the micro in a reset condition for a programmable time interval to allow the system operating voltages and clock to stabilize before executing code.

The typical delay time interval can be estimated using the following equation:

$$t_{\text{DELAY}} = ((3.4\text{V} \times C_{\text{DELAY}}) / I_{\text{DELAY}})$$

For a  $C_{\text{DELAY}}$  value of  $0.1 \mu\text{F}$  and a typical  $I_{\text{DELAY}}$  of  $12 \mu\text{A}$ , the typical delay time will be:

$$t_{\text{DELAY}} = ((3.4\text{V} \times 0.1 \mu\text{F}) / 12 \mu\text{A}) = 28.3 \text{ ms}$$

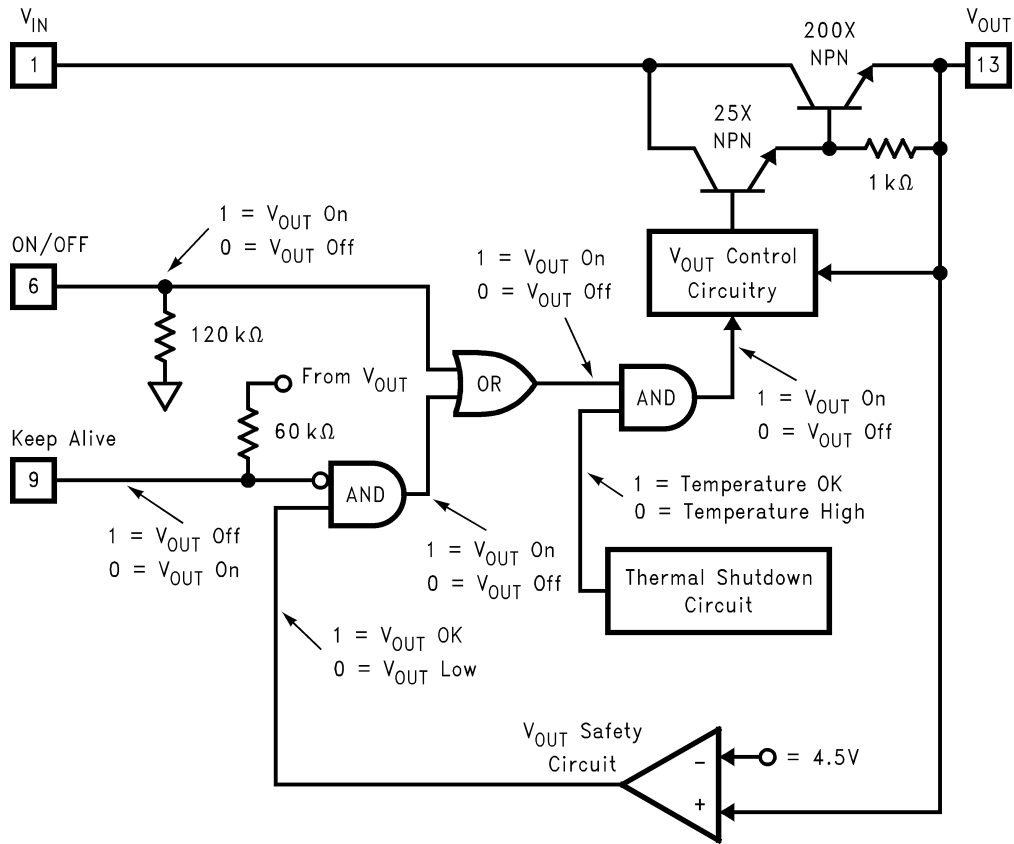

10130526

#### MICROPROCESSOR SYSTEM REGULATOR WITH KEEP-ALIVE INTERVAL AT TURN-OFF

The following circuit illustrates a system application utilizing both of the logic control inputs of the LM9074. Closing the ON/OFF switch powers ON the system. Once powered, the system controller sets the Keep-Alive line low. The NPN transistor is used only to signal the controller that the ON/

OFF switch has been opened and the system is to be turned OFF. Upon detecting this high level at the ON/OFF Sense input line, the controller can then perform a power down routine. The system will remain fully powered until the controller commands total shut down by taking the Keep-Alive line high. The system then shuts OFF and reverts to a very low current drain standby condition until switched back on.

Application Information (Continued)

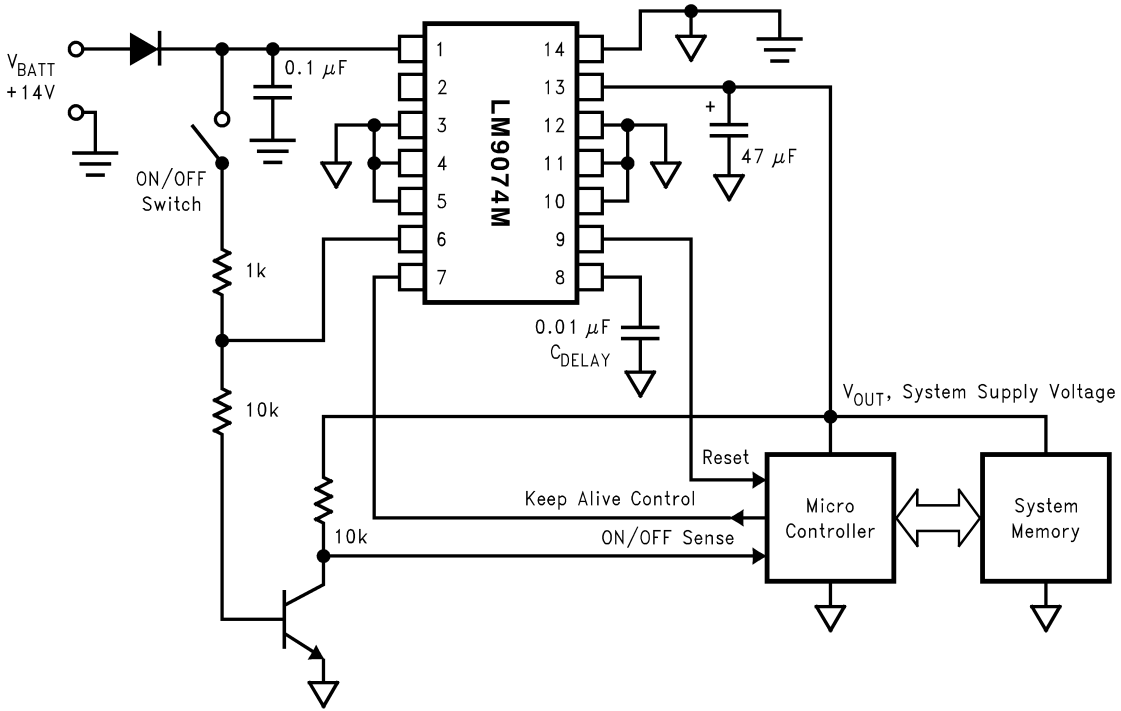

Control Waveforms

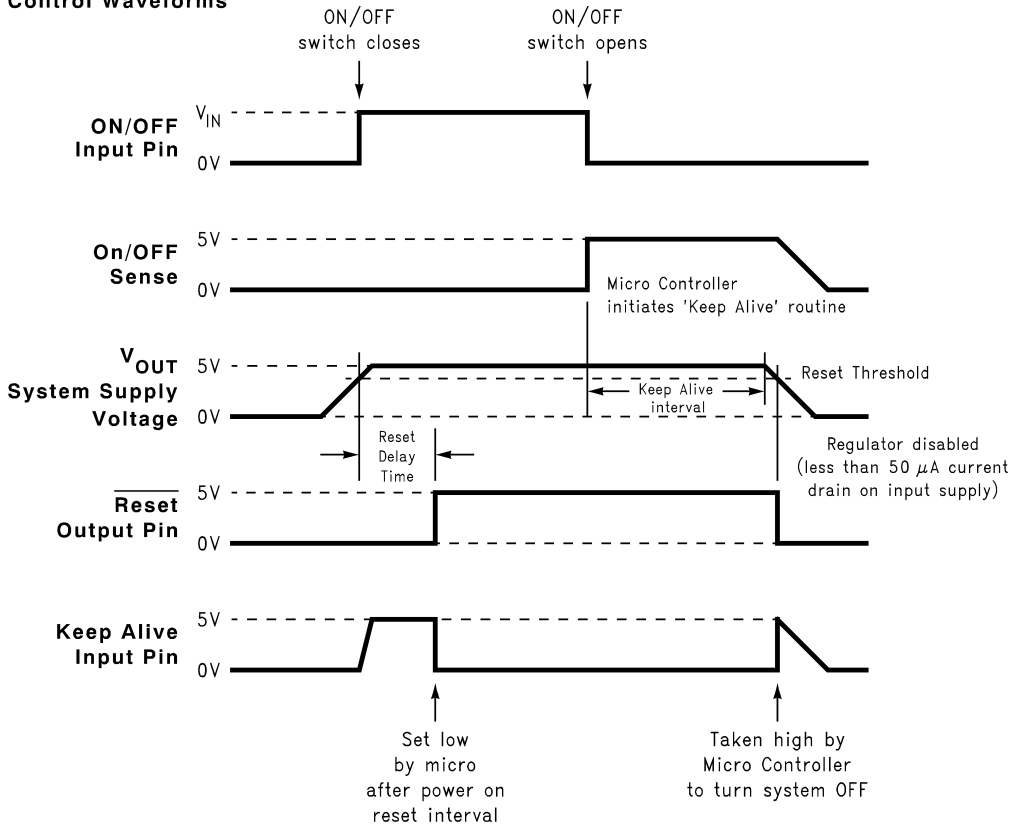

10130525

## Physical Dimensions inches (millimeters) unless otherwise noted

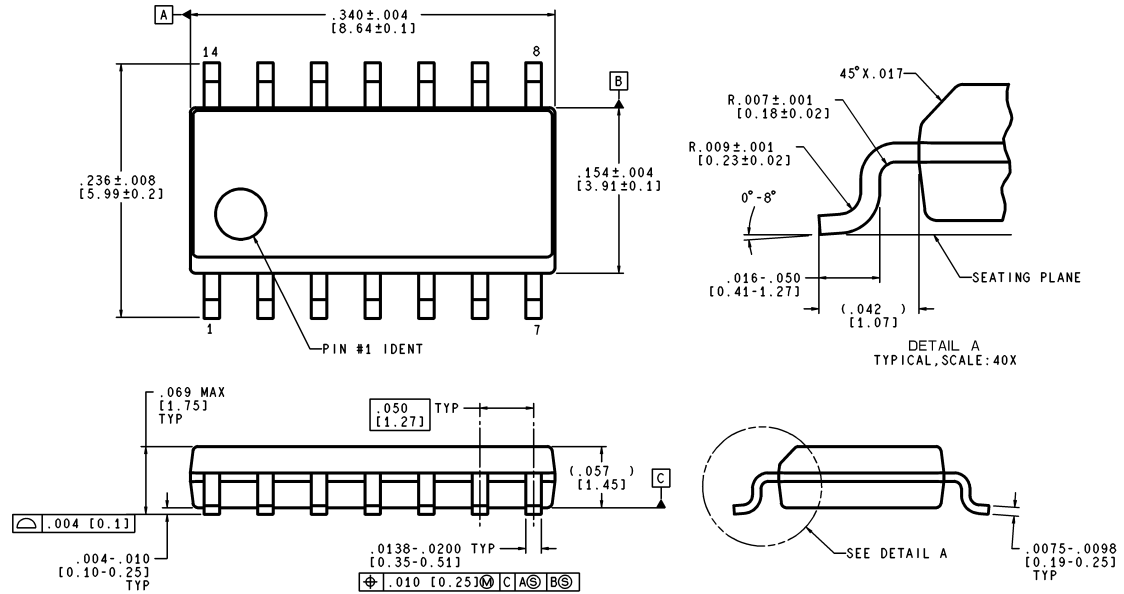

CONTROLLING DIMENSION IS INCH  
VALUES IN [ ] ARE MILLIMETERS

M14A (Rev. J)

**14-Lead (0.150" Wide) Molded SO Package**  
**Order Number LM9074M**  
**NS Package Number M14A**

National does not assume any responsibility for use of any circuitry described, no circuit patent licenses are implied and National reserves the right at any time without notice to change said circuitry and specifications.

For the most current product information visit us at [www.national.com](http://www.national.com).

### LIFE SUPPORT POLICY

NATIONAL'S PRODUCTS ARE NOT AUTHORIZED FOR USE AS CRITICAL COMPONENTS IN LIFE SUPPORT DEVICES OR SYSTEMS WITHOUT THE EXPRESS WRITTEN APPROVAL OF THE PRESIDENT AND GENERAL COUNSEL OF NATIONAL SEMICONDUCTOR CORPORATION. As used herein:

1. Life support devices or systems are devices or systems which, (a) are intended for surgical implant into the body, or (b) support or sustain life, and whose failure to perform when properly used in accordance with instructions for use provided in the labeling, can be reasonably expected to result in a significant injury to the user.
2. A critical component is any component of a life support device or system whose failure to perform can be reasonably expected to cause the failure of the life support device or system, or to affect its safety or effectiveness.

### BANNED SUBSTANCE COMPLIANCE

National Semiconductor manufactures products and uses packing materials that meet the provisions of the Customer Products Stewardship Specification (CSP-9-111C2) and the Banned Substances and Materials of Interest Specification (CSP-9-111S2) and contain no "Banned Substances" as defined in CSP-9-111S2.

Leadfree products are RoHS compliant.



**National Semiconductor**  
**Americas Customer**  
**Support Center**  
 Email: [new.feedback@nsc.com](mailto:new.feedback@nsc.com)  
 Tel: 1-800-272-9959

**National Semiconductor**  
**Europe Customer Support Center**  
 Fax: +49 (0) 180-530 85 86  
 Email: [europa.support@nsc.com](mailto:europa.support@nsc.com)  
 Deutsch Tel: +49 (0) 69 9508 6208  
 English Tel: +44 (0) 870 24 0 2171  
 Français Tel: +33 (0) 1 41 91 8790

**National Semiconductor**  
**Asia Pacific Customer**  
**Support Center**  
 Email: [ap.support@nsc.com](mailto:ap.support@nsc.com)

**National Semiconductor**  
**Japan Customer Support Center**  
 Fax: 81-3-5639-7507  
 Email: [jpn.feedback@nsc.com](mailto:jpn.feedback@nsc.com)  
 Tel: 81-3-5639-7560

## IMPORTANT NOTICE

Texas Instruments Incorporated and its subsidiaries (TI) reserve the right to make corrections, modifications, enhancements, improvements, and other changes to its products and services at any time and to discontinue any product or service without notice. Customers should obtain the latest relevant information before placing orders and should verify that such information is current and complete. All products are sold subject to TI's terms and conditions of sale supplied at the time of order acknowledgment.

TI warrants performance of its hardware products to the specifications applicable at the time of sale in accordance with TI's standard warranty. Testing and other quality control techniques are used to the extent TI deems necessary to support this warranty. Except where mandated by government requirements, testing of all parameters of each product is not necessarily performed.

TI assumes no liability for applications assistance or customer product design. Customers are responsible for their products and applications using TI components. To minimize the risks associated with customer products and applications, customers should provide adequate design and operating safeguards.

TI does not warrant or represent that any license, either express or implied, is granted under any TI patent right, copyright, mask work right, or other TI intellectual property right relating to any combination, machine, or process in which TI products or services are used. Information published by TI regarding third-party products or services does not constitute a license from TI to use such products or services or a warranty or endorsement thereof. Use of such information may require a license from a third party under the patents or other intellectual property of the third party, or a license from TI under the patents or other intellectual property of TI.

Reproduction of TI information in TI data books or data sheets is permissible only if reproduction is without alteration and is accompanied by all associated warranties, conditions, limitations, and notices. Reproduction of this information with alteration is an unfair and deceptive business practice. TI is not responsible or liable for such altered documentation. Information of third parties may be subject to additional restrictions.

Resale of TI products or services with statements different from or beyond the parameters stated by TI for that product or service voids all express and any implied warranties for the associated TI product or service and is an unfair and deceptive business practice. TI is not responsible or liable for any such statements.

TI products are not authorized for use in safety-critical applications (such as life support) where a failure of the TI product would reasonably be expected to cause severe personal injury or death, unless officers of the parties have executed an agreement specifically governing such use. Buyers represent that they have all necessary expertise in the safety and regulatory ramifications of their applications, and acknowledge and agree that they are solely responsible for all legal, regulatory and safety-related requirements concerning their products and any use of TI products in such safety-critical applications, notwithstanding any applications-related information or support that may be provided by TI. Further, Buyers must fully indemnify TI and its representatives against any damages arising out of the use of TI products in such safety-critical applications.

TI products are neither designed nor intended for use in military/aerospace applications or environments unless the TI products are specifically designated by TI as military-grade or "enhanced plastic." Only products designated by TI as military-grade meet military specifications. Buyers acknowledge and agree that any such use of TI products which TI has not designated as military-grade is solely at the Buyer's risk, and that they are solely responsible for compliance with all legal and regulatory requirements in connection with such use.

TI products are neither designed nor intended for use in automotive applications or environments unless the specific TI products are designated by TI as compliant with ISO/TS 16949 requirements. Buyers acknowledge and agree that, if they use any non-designated products in automotive applications, TI will not be responsible for any failure to meet such requirements.

Following are URLs where you can obtain information on other Texas Instruments products and application solutions:

### Products

Audio	<a href="http://www.ti.com/audio">www.ti.com/audio</a>
Amplifiers	<a href="http://amplifier.ti.com">amplifier.ti.com</a>
Data Converters	<a href="http://dataconverter.ti.com">dataconverter.ti.com</a>
DLP® Products	<a href="http://www.dlp.com">www.dlp.com</a>
DSP	<a href="http://dsp.ti.com">dsp.ti.com</a>
Clocks and Timers	<a href="http://www.ti.com/clocks">www.ti.com/clocks</a>
Interface	<a href="http://interface.ti.com">interface.ti.com</a>
Logic	<a href="http://logic.ti.com">logic.ti.com</a>
Power Mgmt	<a href="http://power.ti.com">power.ti.com</a>
Microcontrollers	<a href="http://microcontroller.ti.com">microcontroller.ti.com</a>
RFID	<a href="http://www.ti-rfid.com">www.ti-rfid.com</a>
OMAP Mobile Processors	<a href="http://www.ti.com/omap">www.ti.com/omap</a>
Wireless Connectivity	<a href="http://www.ti.com/wirelessconnectivity">www.ti.com/wirelessconnectivity</a>

### Applications

Communications and Telecom	<a href="http://www.ti.com/communications">www.ti.com/communications</a>
Computers and Peripherals	<a href="http://www.ti.com/computers">www.ti.com/computers</a>
Consumer Electronics	<a href="http://www.ti.com/consumer-apps">www.ti.com/consumer-apps</a>
Energy and Lighting	<a href="http://www.ti.com/energy">www.ti.com/energy</a>
Industrial	<a href="http://www.ti.com/industrial">www.ti.com/industrial</a>
Medical	<a href="http://www.ti.com/medical">www.ti.com/medical</a>
Security	<a href="http://www.ti.com/security">www.ti.com/security</a>
Space, Avionics and Defense	<a href="http://www.ti.com/space-avionics-defense">www.ti.com/space-avionics-defense</a>
Transportation and Automotive	<a href="http://www.ti.com/automotive">www.ti.com/automotive</a>
Video and Imaging	<a href="http://www.ti.com/video">www.ti.com/video</a>

TI E2E Community Home Page

[e2e.ti.com](http://e2e.ti.com)

Mailing Address: Texas Instruments, Post Office Box 655303, Dallas, Texas 75265  
Copyright © 2011, Texas Instruments Incorporated

## Looking for pricing, stock, or lifecycle information?

Click below to explore more details on WIN SOURCE:

 [View LM9074M/NOPB on WIN SOURCE](#)

 [Texas Instruments](#) Information

## Optimize Your Supply Chain with WIN SOURCE Solutions

-  Global Sourcing Solution
-  Obsolete Management
-  Cost Control Management
-  Shortage Management
-  Alternative Solution
-  Excess Inventory Management