

PHX18NQ11T

N-channel TrenchMOS™ standard level FET

Rev. 02 — 24 March 2005

Product data sheet

1. Product profile

1.1 General description

Standard level N-channel enhancement mode Field-Effect Transistor (FET) in a fully isolated plastic package using TrenchMOS™ technology.

1.2 Features

- Standard level threshold
- Low on-state resistance
- Low thermal resistance
- Isolated mounting base
- Fast switching
- Lead-free

1.3 Applications

- DC-to-DC converters
- Class-D amplifiers
- Switched-mode power supplies

1.4 Quick reference data

- $V_{DS} \leq 110$ V
- $I_D \leq 12.5$ A
- $R_{DSon} \leq 90$ m Ω
- $P_{tot} \leq 31.2$ W

2. Pinning information

Table 1: Pinning

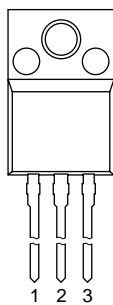
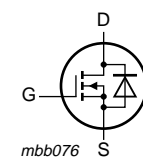
Pin	Description	Simplified outline	Symbol
1	gate		
2	drain		
3	source		
mb	mounting base; isolated		

SOT186A (3-lead TO-220F)

PHILIPS

3. Ordering information

Table 2: Ordering information

Type number	Package		Version
	Name	Description	
PHX18NQ11T	TO-220F	plastic single-ended package; isolated heatsink mounted; 1 mounting hole; 3 leads	SOT186A

4. Limiting values

Table 3: Limiting values

In accordance with the Absolute Maximum Rating System (IEC 60134).

Symbol	Parameter	Conditions	Min	Max	Unit	
V_{DS}	drain-source voltage (DC)	$25\text{ °C} \leq T_j \leq 150\text{ °C}$	-	110	V	
V_{DGR}	drain-gate voltage (DC)	$25\text{ °C} \leq T_j \leq 150\text{ °C}$; $R_{GS} = 20\text{ k}\Omega$	-	110	V	
V_{GS}	gate-source voltage (DC)		-	± 20	V	
I_D	drain current (DC)	$T_h = 25\text{ °C}$; $V_{GS} = 10\text{ V}$; Figure 2 and 3	[1]	-	12.5	A
		$T_h = 100\text{ °C}$; $V_{GS} = 10\text{ V}$; Figure 2	[1]	-	7.9	A
I_{DM}	peak drain current	$T_h = 25\text{ °C}$; pulsed; $t_p \leq 10\text{ }\mu\text{s}$; Figure 3	[1]	-	50.2	A
P_{tot}	total power dissipation	$T_h = 25\text{ °C}$; Figure 1	[1]	-	31.2	W
T_{stg}	storage temperature		-55	+150	°C	
T_j	junction temperature		-55	+150	°C	
Source-drain diode						
I_S	source (diode forward) current (DC)	$T_h = 25\text{ °C}$	[1]	-	12.5	A
I_{SM}	peak source (diode forward) current	$T_h = 25\text{ °C}$; pulsed; $t_p \leq 10\text{ }\mu\text{s}$	[1]	-	50.2	A
Avalanche ruggedness						
$E_{DS(AL)S}$	non-repetitive drain-source avalanche energy	unclamped inductive load; $I_D = 7.5\text{ A}$; $t_p = 0.09\text{ ms}$; $V_{DD} \leq 15\text{ V}$; $R_{GS} = 50\text{ }\Omega$; $V_{GS} = 10\text{ V}$; starting at $T_j = 25\text{ °C}$	-	56	mJ	

[1] External heatsink connected to mounting base.

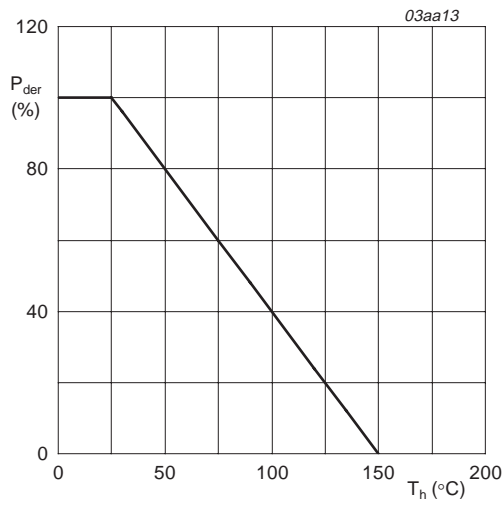

$$P_{der} = \frac{P_{tot}}{P_{tot(25^\circ\text{C})}} \times 100\%$$

Fig 1. Normalized total power dissipation as a function of heatsink temperature

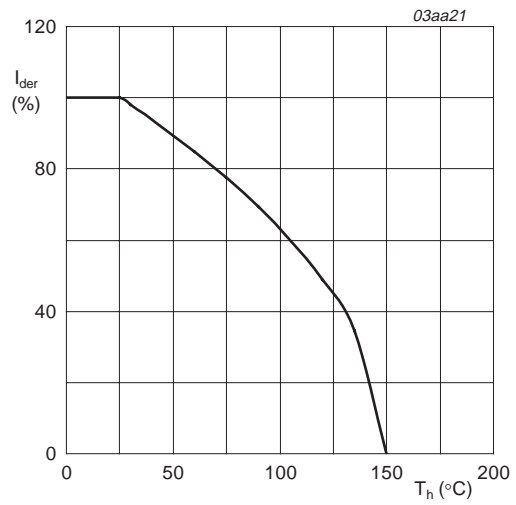

$$I_{der} = \frac{I_D}{I_{D(25^\circ\text{C})}} \times 100\%$$

Fig 2. Normalized continuous drain current as a function of heatsink temperature

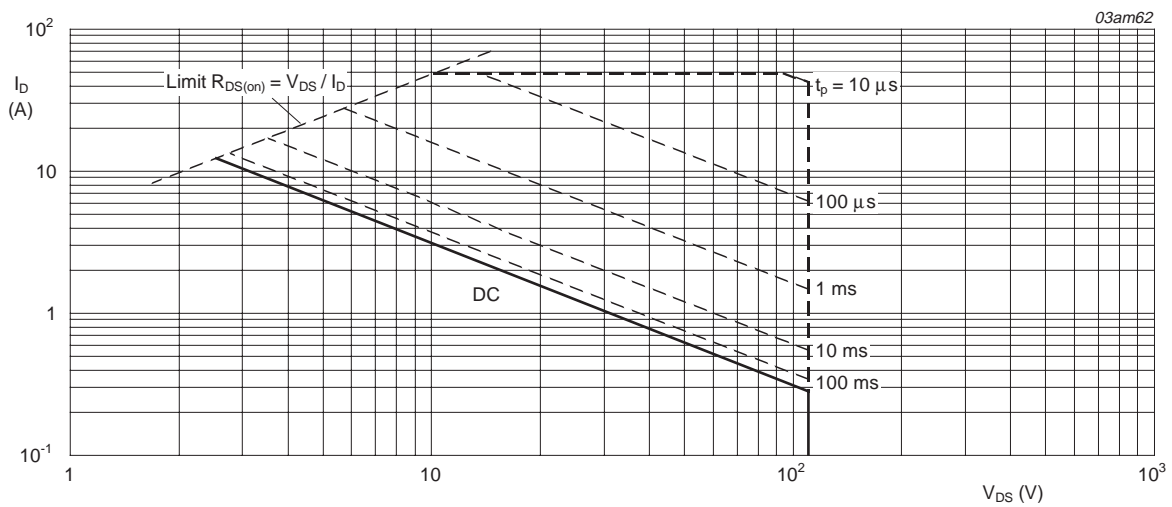

$T_h = 25^\circ\text{C}$; I_{DM} is single pulse; $V_{GS} = 10\text{ V}$

Fig 3. Safe operating area; continuous and peak drain currents as a function of drain-source voltage

5. Thermal characteristics

Table 4: Thermal characteristics

Symbol	Parameter	Conditions	Min	Typ	Max	Unit
$R_{th(j-h)}$	thermal resistance from junction to heatsink	Figure 4	[1]	-	4	K/W

[1] External heatsink connected to mounting base.

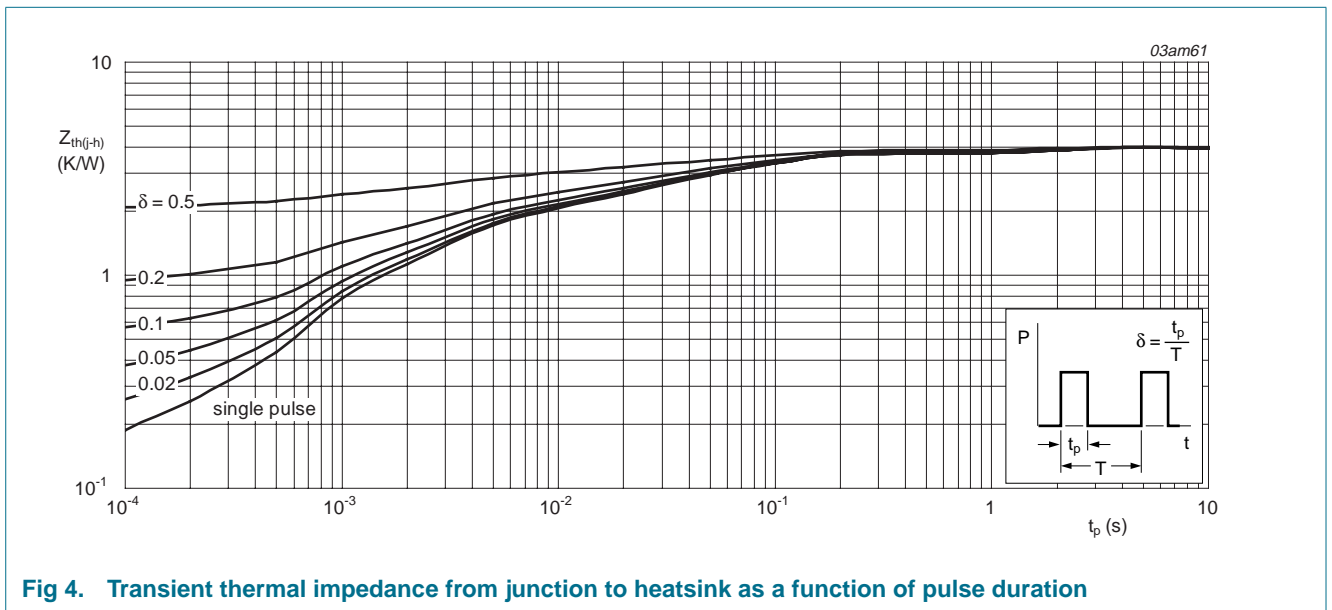
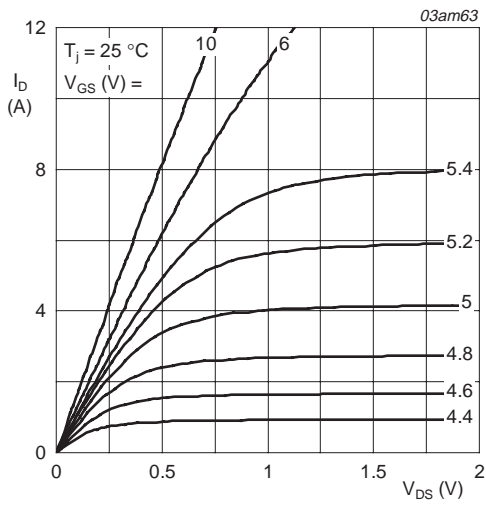

Fig 4. Transient thermal impedance from junction to heatsink as a function of pulse duration

6. Characteristics

Table 5: Characteristics
T_j = 25 °C unless otherwise specified.

Symbol	Parameter	Conditions	Min	Typ	Max	Unit
Static characteristics						
V _{(BR)DSS}	drain-source breakdown voltage	I _D = 250 μA; V _{GS} = 0 V				
		T _j = 25 °C	110	-	-	V
		T _j = -55 °C	99	-	-	V
V _{GS(th)}	gate-source threshold voltage	I _D = 1 mA; V _{DS} = V _{GS} ; Figure 9 and 10				
		T _j = 25 °C	2	3	4	V
		T _j = 150 °C	1.2	-	-	V
		T _j = -55 °C	-	-	4.4	V
I _{DSS}	drain-source leakage current	V _{DS} = 100 V; V _{GS} = 0 V				
		T _j = 25 °C	-	-	1	μA
		T _j = 150 °C	-	-	500	μA
I _{GSS}	gate-source leakage current	V _{GS} = ±10 V; V _{DS} = 0 V	-	10	100	nA
R _{DS(on)}	drain-source on-state resistance	V _{GS} = 10 V; I _D = 9 A; Figure 6 and 8				
		T _j = 25 °C	-	67	90	mΩ
		T _j = 150 °C	-	148	198	mΩ
Dynamic characteristics						
Q _{g(tot)}	total gate charge	I _D = 3 A; V _{DD} = 80 V; V _{GS} = 10 V; Figure 13	-	21	-	nC
Q _{gs}	gate-source charge		-	2.5	-	nC
Q _{gd}	gate-drain (Miller) charge		-	8	-	nC
C _{iss}	input capacitance	V _{GS} = 0 V; V _{DS} = 25 V; f = 1 MHz; Figure 11	-	635	-	pF
C _{oss}	output capacitance		-	105	-	pF
C _{rss}	reverse transfer capacitance		-	60	-	pF
t _{d(on)}	turn-on delay time	V _{DD} = 50 V; R _L = 15 Ω; V _{GS} = 10 V;	-	6	-	ns
t _r	rise time	R _G = 5.6 Ω	-	12	-	ns
t _{d(off)}	turn-off delay time		-	20	-	ns
t _f	fall time		-	10	-	ns
Source-drain diode						
V _{SD}	source-drain (diode forward) voltage	I _S = 12 A; V _{GS} = 0 V; Figure 12	-	0.87	1.2	V
t _{rr}	reverse recovery time	I _S = 12 A; dI _S /dt = -100 A/μs; V _{GS} = 0 V	-	55	-	ns
Q _r	recovered charge		-	135	-	nC



$T_j = 25\text{ °C}$

Fig 5. Output characteristics: drain current as a function of drain-source voltage; typical values

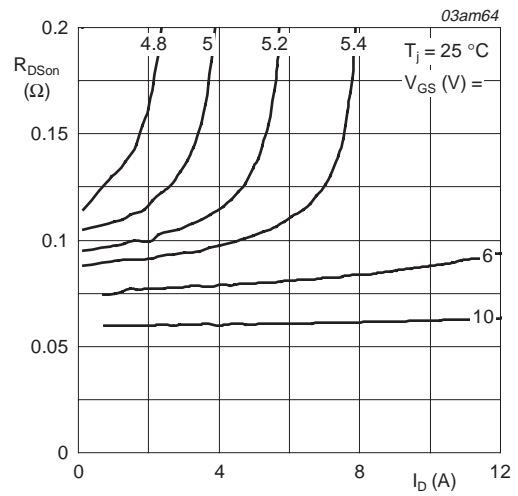

$T_j = 25\text{ °C}$

Fig 6. Drain-source on-state resistance as a function of drain current; typical values

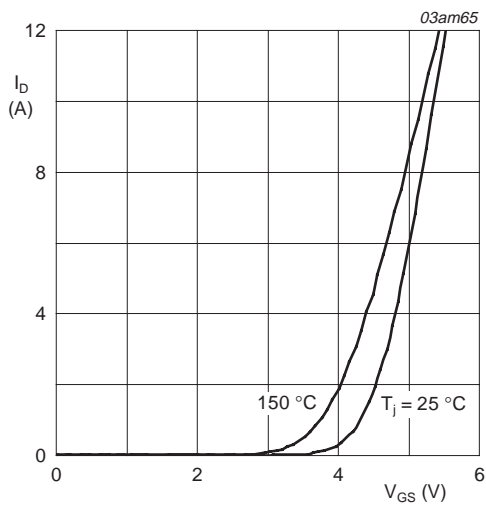

$T_j = 25\text{ °C and } 150\text{ °C}; V_{DS} > I_D \times R_{DS(on)}$

Fig 7. Transfer characteristics: drain current as a function of gate-source voltage; typical values

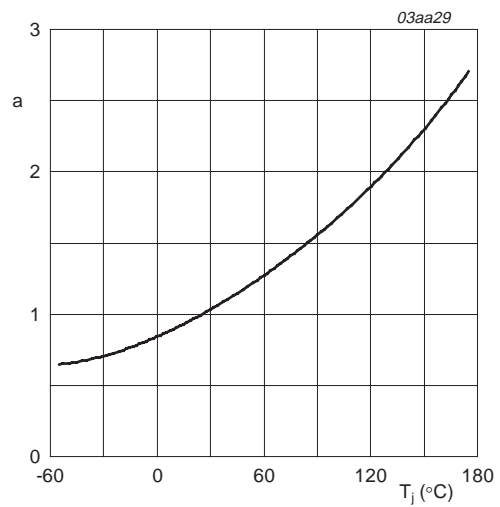

$$a = \frac{R_{DS(on)}}{R_{DS(on)(25\text{ °C})}}$$

Fig 8. Normalized drain-source on-state resistance factor as a function of junction temperature

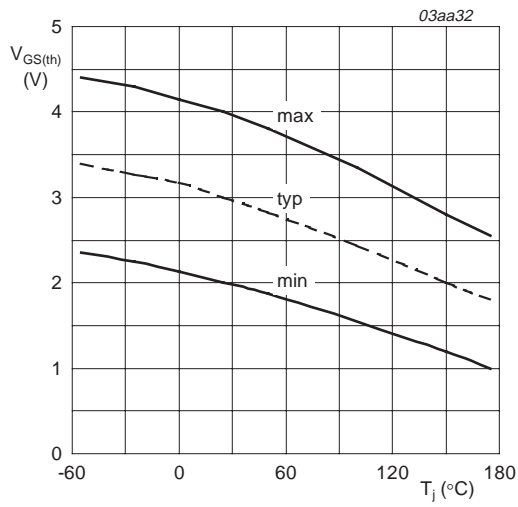

$I_D = 1 \text{ mA}; V_{DS} = V_{GS}$

Fig 9. Gate-source threshold voltage as a function of junction temperature

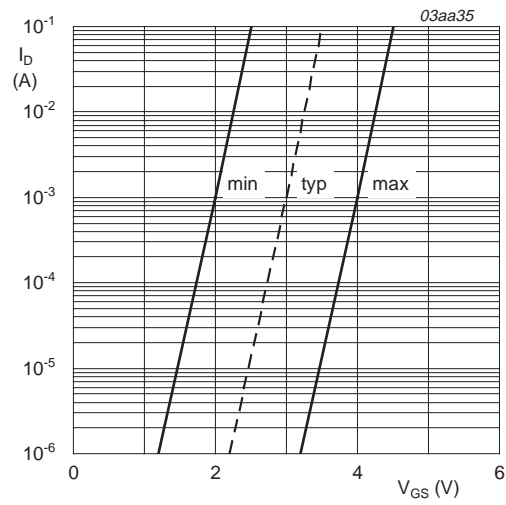

$T_j = 25 \text{ }^\circ\text{C}; V_{DS} = 5 \text{ V}$

Fig 10. Sub-threshold drain current as a function of gate-source voltage

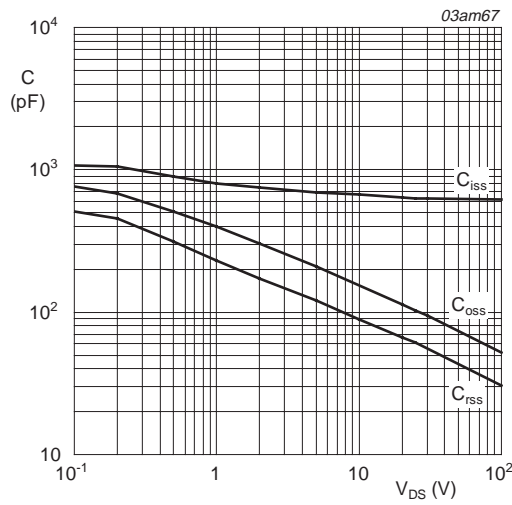

$V_{GS} = 0 \text{ V}; f = 1 \text{ MHz}$

Fig 11. Input, output and reverse transfer capacitances as a function of drain-source voltage; typical values

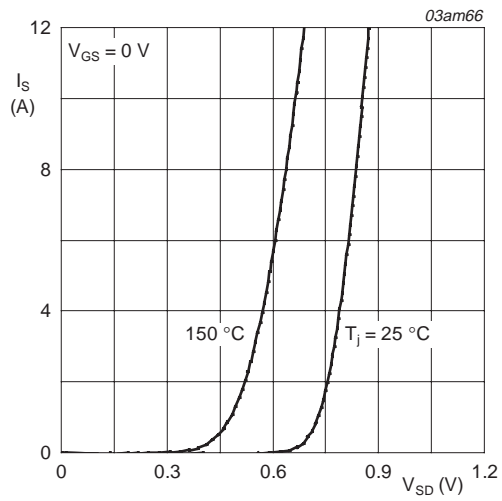

$T_J = 25^\circ\text{C}$ and 150°C ; $V_{GS} = 0\text{ V}$

Fig 12. Source (diode forward) current as a function of source-drain (diode forward) voltage; typical values

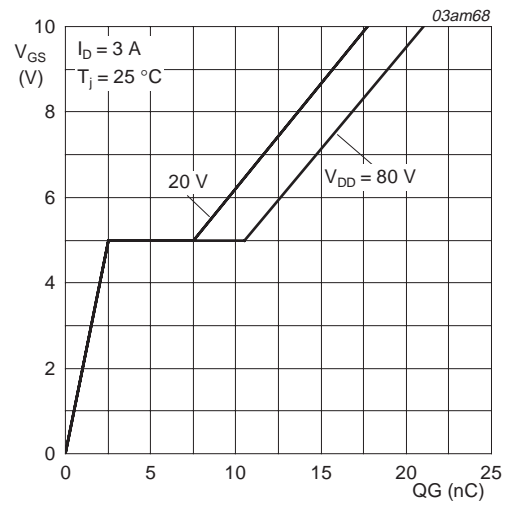

$I_D = 3\text{ A}$; $V_{DD} = 20\text{ V}$ and 80 V

Fig 13. Gate-source voltage as a function of gate charge; typical values

7. Isolation characteristics

Table 6: Isolation Characteristics

Symbol	Parameter	Conditions	Min	Typ	Max	Unit
$V_{(isol)RMS}$	RMS isolation voltage from all three terminals to external heatsink	$f = 50\text{-}60\text{ Hz}$; sinusoidal waveform; $RH \leq 65\%$; clean and dust-free	-	-	2500	V
$C_{(d-h)}$	Capacitance from drain to external heatsink		-	10	-	pF

8. Package outline

Plastic single-ended package; isolated heatsink mounted;
1 mounting hole; 3 lead TO-220 'full pack'

SOT186A

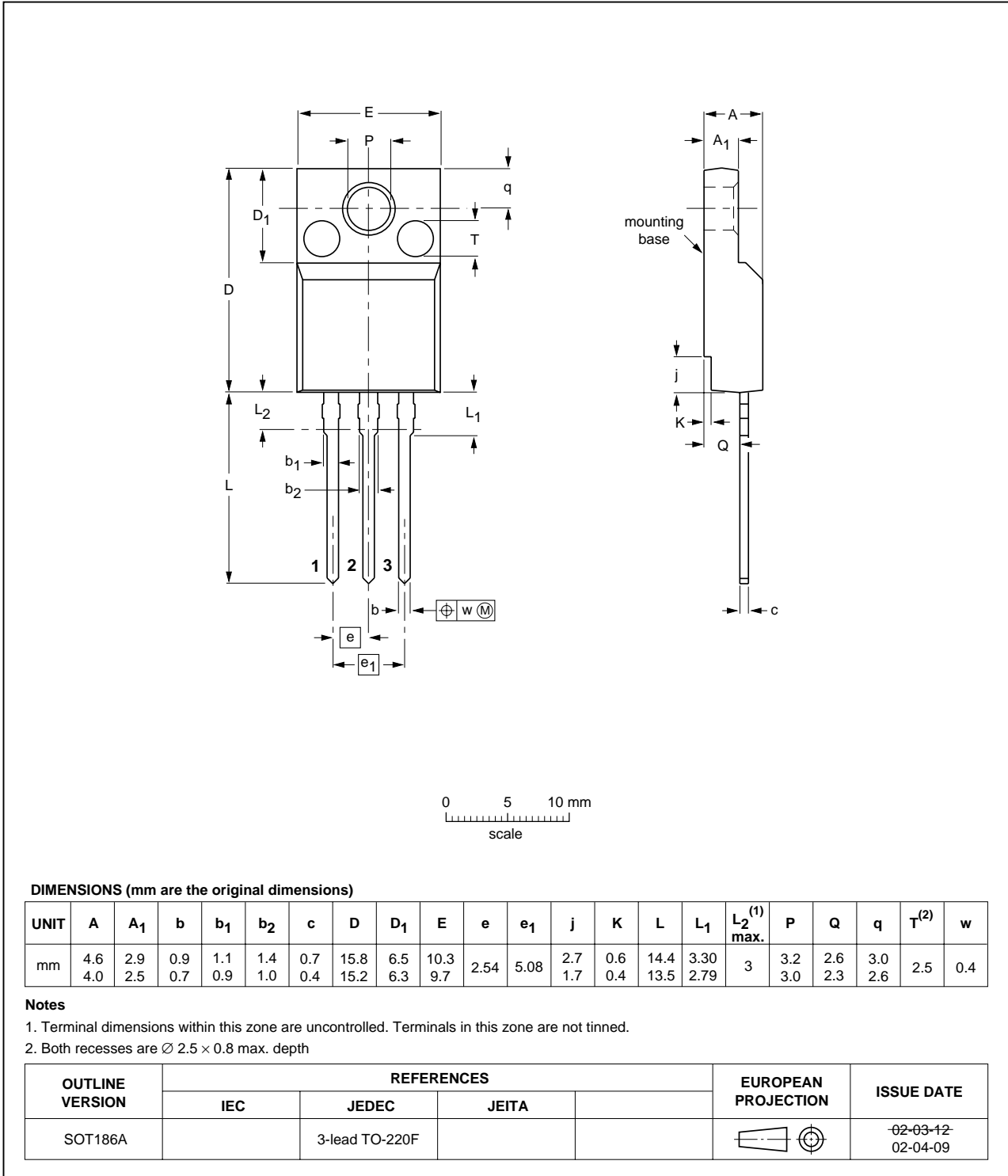

Fig 14. Package outline SOT186A (3-lead TO-220F)

9. Revision history

Table 7: Revision history

Document ID	Release date	Data sheet status	Change notice	Doc. number	Supersedes
PHX18NQ11T_2	20050324	Product data sheet	-	9397 750 14444	PHX18NQ11T-01
Modifications:					
					<ul style="list-style-type: none">• The format of this data sheet has been redesigned to comply with the new presentation and information standard of Philips Semiconductors.• Table 1 "Pinning": description corrected• Section 1.2 "Features" and Section 1.3 "Applications": information added
PHX18NQ11T-01	20040213	Product data	-	9397 750 12915	-

10. Data sheet status

Level	Data sheet status ^[1]	Product status ^{[2] [3]}	Definition
I	Objective data	Development	This data sheet contains data from the objective specification for product development. Philips Semiconductors reserves the right to change the specification in any manner without notice.
II	Preliminary data	Qualification	This data sheet contains data from the preliminary specification. Supplementary data will be published at a later date. Philips Semiconductors reserves the right to change the specification without notice, in order to improve the design and supply the best possible product.
III	Product data	Production	This data sheet contains data from the product specification. Philips Semiconductors reserves the right to make changes at any time in order to improve the design, manufacturing and supply. Relevant changes will be communicated via a Customer Product/Process Change Notification (CPCN).

[1] Please consult the most recently issued data sheet before initiating or completing a design.

[2] The product status of the device(s) described in this data sheet may have changed since this data sheet was published. The latest information is available on the Internet at URL <http://www.semiconductors.philips.com>.

[3] For data sheets describing multiple type numbers, the highest-level product status determines the data sheet status.

11. Definitions

Short-form specification — The data in a short-form specification is extracted from a full data sheet with the same type number and title. For detailed information see the relevant data sheet or data handbook.

Limiting values definition — Limiting values given are in accordance with the Absolute Maximum Rating System (IEC 60134). Stress above one or more of the limiting values may cause permanent damage to the device. These are stress ratings only and operation of the device at these or at any other conditions above those given in the Characteristics sections of the specification is not implied. Exposure to limiting values for extended periods may affect device reliability.

Application information — Applications that are described herein for any of these products are for illustrative purposes only. Philips Semiconductors make no representation or warranty that such applications will be suitable for the specified use without further testing or modification.

12. Disclaimers

Life support — These products are not designed for use in life support appliances, devices, or systems where malfunction of these products can reasonably be expected to result in personal injury. Philips Semiconductors

14. Contact information

For additional information, please visit: <http://www.semiconductors.philips.com>

For sales office addresses, send an email to: sales.addresses@www.semiconductors.philips.com

customers using or selling these products for use in such applications do so at their own risk and agree to fully indemnify Philips Semiconductors for any damages resulting from such application.

Right to make changes — Philips Semiconductors reserves the right to make changes in the products - including circuits, standard cells, and/or software - described or contained herein in order to improve design and/or performance. When the product is in full production (status 'Production'), relevant changes will be communicated via a Customer Product/Process Change Notification (CPCN). Philips Semiconductors assumes no responsibility or liability for the use of any of these products, conveys no license or title under any patent, copyright, or mask work right to these products, and makes no representations or warranties that these products are free from patent, copyright, or mask work right infringement, unless otherwise specified.

13. Trademarks

TrenchMOS — is a trademark of Koninklijke Philips Electronics N.V.

15. Contents

1	Product profile	1
1.1	General description	1
1.2	Features	1
1.3	Applications	1
1.4	Quick reference data	1
2	Pinning information	1
3	Ordering information	2
4	Limiting values	2
5	Thermal characteristics	4
6	Characteristics	5
7	Isolation characteristics	8
8	Package outline	9
9	Revision history	10
10	Data sheet status	11
11	Definitions	11
12	Disclaimers	11
13	Trademarks	11
14	Contact information	11



© Koninklijke Philips Electronics N.V. 2005



All rights are reserved. Reproduction in whole or in part is prohibited without the prior written consent of the copyright owner. The information presented in this document does not form part of any quotation or contract, is believed to be accurate and reliable and may be changed without notice. No liability will be accepted by the publisher for any consequence of its use. Publication thereof does not convey nor imply any license under patent- or other industrial or intellectual property rights.

Date of release: 24 March 2005
Document number: 9397 750 14444

Published in The Netherlands

Looking for pricing, stock, or lifecycle information?

Click below to explore more details on WIN SOURCE:

-  [View PHX18NQ11T,127 on WIN SOURCE](#)
-  [NXP / Nexperia Information](#)

Optimize Your Supply Chain with WIN SOURCE Solutions

-  Global Sourcing Solution
-  Obsolete Management
-  Cost Control Management
-  Shortage Management
-  Alternative Solution
-  Excess Inventory Management