



**THE DATASHEET OF  
L9959T-TR-D**



## Single and dual PMOS high-side H-bridge

Datasheet - production data

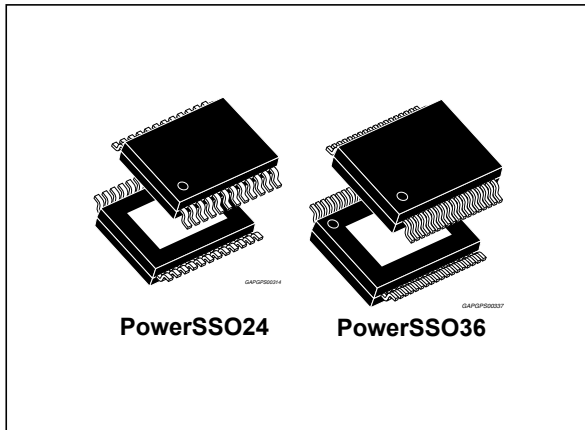

- Current-monitoring with current feedback output signal CF
- SPI-interface for configuration and diagnosis
- Error history in second diagnosis register
- Two independent enable pins: "/ABE" and "DIS"
- Control of power stages by SPI or two input signals, PWM and DIR (configurable via SPI)
- Logic levels 5 V compatible
- Conformity to improved EMC requirements due to smart H-bridge switching

### Features

- Full path  $R_{DS(ON)}$  less than 540 m $\Omega$
- Continuous load current > 3 A
- Operating battery supply voltage 5 V to 28 V
- Operating  $V_{DD}$  supply voltage 4.5 V to 5.5 V
- All ECU internal pins can withstand up to 18 V
- Output switching frequency up to 11 kHz
- Monitoring of  $V_{DD}$  supply voltage
- SPI programmable output current limitation from 5 A to 8.6 A (in 3 steps)
- Over temperature and short circuit protection
- Full diagnosis capability
- Fast switch-off open-drain input/output

### Description

L9959S/L9959U and L9959T are single and dual integrated H-bridges for resistive and inductive loads featuring output current direction and supervising functions.

The PowerSSO24 houses one full H-Bridge, while the PowerSSO36 houses both two H-Bridges that can work in parallel, through independent input driving commands, and one full H-bridge, by improving PCB footprint design versus different target applications.

Target application ranges from throttle control actuators to exhaust gas recirculation control valves in automotive domain to a more general use to drive DC and Stepper motors.

Table 1. Device summary

Order code	Package	Packing
L9959S-TR-D	PowerSSO24	Tape & Reel
L9959T-TR-D	PowerSSO36	Tape & Reel
L9959U-TR-D	PowerSSO36	Tape & Reel

# Contents

<b>1</b>	<b>Block diagram</b> .....	<b>6</b>
<b>2</b>	<b>Pins description</b> .....	<b>7</b>
2.1	Pin definitions and functions .....	8
<b>3</b>	<b>Electrical specifications</b> .....	<b>13</b>
3.1	Absolute maximum ratings .....	13
3.2	ESD protection .....	13
3.3	Thermal data .....	14
3.4	Electrical characteristics .....	14
3.5	Outputs OUT1 and OUT2 .....	16
3.6	Temperature dependent current reduction .....	20
3.7	Free-wheeling diodes .....	20
3.8	SPI / logic electrical characteristics .....	21
<b>4</b>	<b>Application information</b> .....	<b>23</b>
4.1	Power stage switching behavior .....	23
4.1.1	PWM mode (same current direction) .....	23
4.1.2	DIR-change mode .....	24
4.2	Protection and monitoring .....	25
4.2.1	Current feedback .....	26
4.2.2	Current limitation .....	27
4.2.3	Temperature dependent current reduction .....	27
4.2.4	Short to battery (SCB) and short to Ground (SCG) .....	28
4.2.5	Short circuit over load (SCL) .....	28
4.2.6	Open load (OL) .....	29
4.3	VS-undervoltage .....	29
4.4	Inverse current at $V_S$ .....	29
4.5	/ABE pin .....	30
4.6	VDD-monitor .....	30
4.7	VDD-monitor test .....	30
4.8	Power-on reset .....	31

---

<b>5</b>	<b>SPI functional description</b> .....	<b>32</b>
5.1	General description .....	32
5.1.1	SPI select (SS) .....	32
5.1.2	Serial data In (SI) .....	32
5.1.3	Serial clock (SCK) .....	32
5.1.4	Serial out (SO) .....	32
5.1.5	SPI communication flow .....	32
5.2	SPI-instruction .....	33
5.3	Device register map .....	34
5.4	SPI - control and status registers .....	35
5.4.1	Reset sources .....	40
5.4.2	Configuration registers reset sources .....	40
<b>6</b>	<b>Application circuit</b> .....	<b>41</b>
<b>7</b>	<b>Package information</b> .....	<b>42</b>
7.1	PowerSSO-24 (exposed pad) package information .....	42
7.2	PowerSSO-36 (exposed pad) package information .....	45
<b>8</b>	<b>Revision history</b> .....	<b>48</b>

## List of tables

Table 1.	Device summary . . . . .	1
Table 2.	L9959S PSSO24 pin-out . . . . .	8
Table 3.	L9959T (Two H-Bridge drivers in one package) PSSO36 pin-out . . . . .	9
Table 4.	L9959U (Single version in PSSO36) pin out. . . . .	12
Table 5.	Absolute maximum ratings . . . . .	13
Table 6.	ESD protection . . . . .	13
Table 7.	Thermal data. . . . .	14
Table 8.	Supply. . . . .	14
Table 9.	Power-on reset . . . . .	15
Table 10.	V <sub>DD</sub> monitoring . . . . .	15
Table 11.	Undervoltage shutdown . . . . .	16
Table 12.	On-resistance (4.5 V < V <sub>S</sub> < 28 V) . . . . .	16
Table 13.	Power output switching times (8 V < V <sub>S</sub> < 18 V). . . . .	16
Table 14.	Current feedback (CF) . . . . .	18
Table 15.	Current limiting . . . . .	19
Table 16.	Over-current detection (8 V < V <sub>S</sub> < 18 V) . . . . .	19
Table 17.	Open-load detection . . . . .	20
Table 18.	Retest delay . . . . .	20
Table 19.	Temperature dependent current reduction . . . . .	20
Table 20.	Free-wheel diodes . . . . .	20
Table 21.	Inputs: SI, SS, SCK, DIR, DIS and PWM; Output: SO . . . . .	21
Table 22.	Dynamic characteristics . . . . .	22
Table 23.	Device states with respect to supply voltage . . . . .	31
Table 24.	SPI instruction byte. . . . .	33
Table 25.	Check byte . . . . .	34
Table 26.	Command overview . . . . .	34
Table 27.	Device identifier (ID) . . . . .	35
Table 28.	Revision register (REV) . . . . .	35
Table 29.	DIA_REG1 . . . . .	35
Table 30.	Diagnosis bits (DIA_REG1) . . . . .	36
Table 31.	Diagnosis register 2 (DIA_REG2) . . . . .	36
Table 32.	Diagnosis bits (DIA_REG2) . . . . .	37
Table 33.	Configuration register (CONFIG_REG) . . . . .	37
Table 34.	Current Level (CONFIG_REG) . . . . .	38
Table 35.	Status and configuration register (STATCON_REG) . . . . .	38
Table 36.	Special register (SPECIAL_REG) . . . . .	39
Table 37.	PowerSSO-24 (exposed pad) package mechanical data . . . . .	43
Table 38.	PowerSSO-36 (exposed pad) package mechanical data . . . . .	45
Table 39.	Document revision history. . . . .	48

## List of figures

Figure 1.	Block diagram . . . . .	6
Figure 2.	PSSO24 pin connection (top view) . . . . .	7
Figure 3.	PSSO36 pin connection (top view) . . . . .	7
Figure 4.	PSSO36 (Single version) pin connection (top view) . . . . .	8
Figure 5.	Output delay times (e.g. low-side output) . . . . .	17
Figure 6.	Output rise and fall times . . . . .	17
Figure 7.	Output disable and enable time (/ABE Input) . . . . .	17
Figure 8.	Output disable and enable time (DIS Input) . . . . .	18
Figure 9.	SPI timing information. . . . .	22
Figure 10.	PWM mode current flow . . . . .	23
Figure 11.	PWM mode output voltage . . . . .	24
Figure 12.	DIR-change (current is changing its direction) . . . . .	24
Figure 13.	DIR-change current flow phase 2 . . . . .	25
Figure 14.	DIR-change output voltage . . . . .	25
Figure 15.	Current feedback and current limiting . . . . .	26
Figure 16.	Current limitation. . . . .	27
Figure 17.	Temperature dependent current reduction . . . . .	27
Figure 18.	Current limiting and short circuit . . . . .	28
Figure 19.	Write access . . . . .	33
Figure 20.	Read access . . . . .	33
Figure 21.	Application circuit . . . . .	41
Figure 22.	PowerSSO-24 (exposed pad) package outline. . . . .	42
Figure 23.	PowerSSO-36 (exposed pad) package outline. . . . .	45

# 1 Block diagram

Figure 1. Block diagram

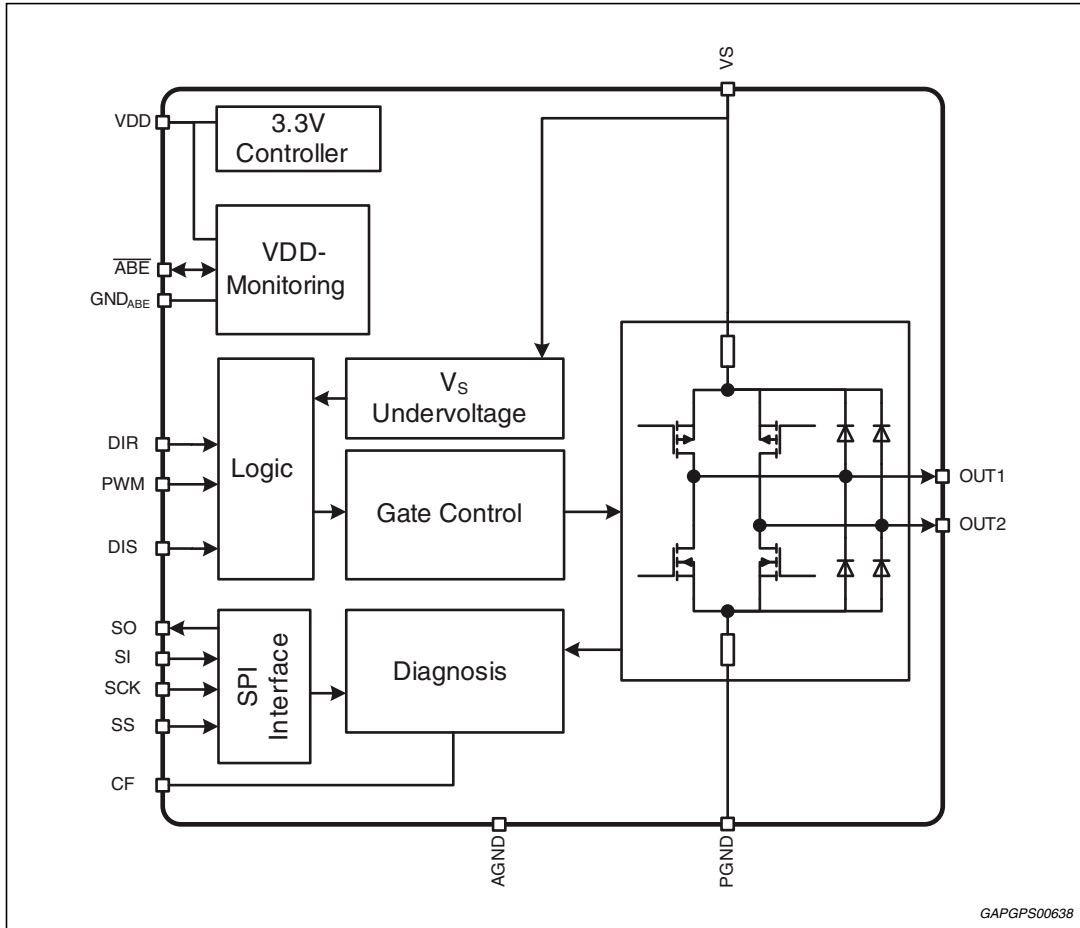

GAPGPS00638

## 2 Pins description

Figure 2. PSSO24 pin connection (top view)

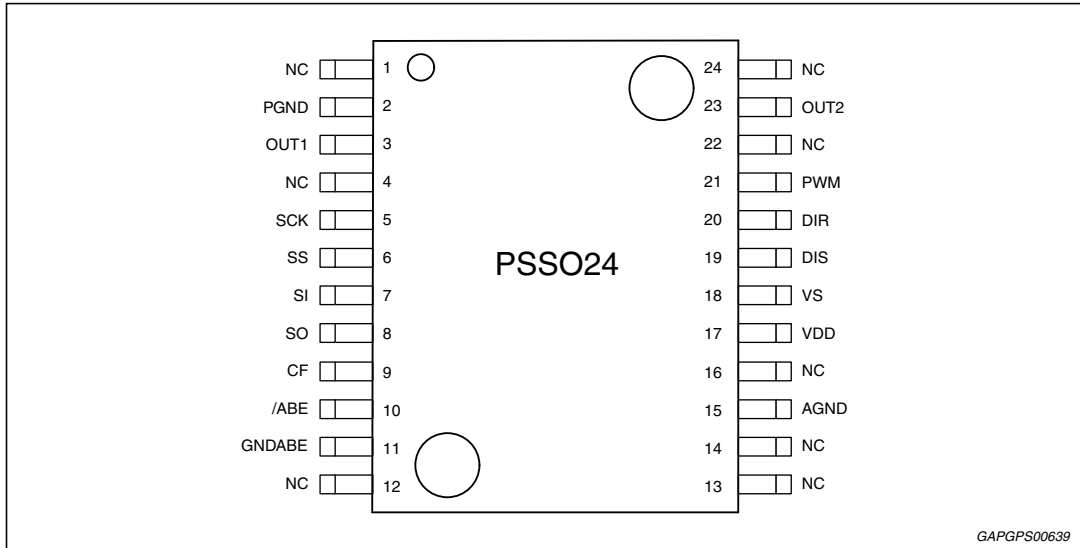

Figure 3. PSSO36 pin connection (top view)

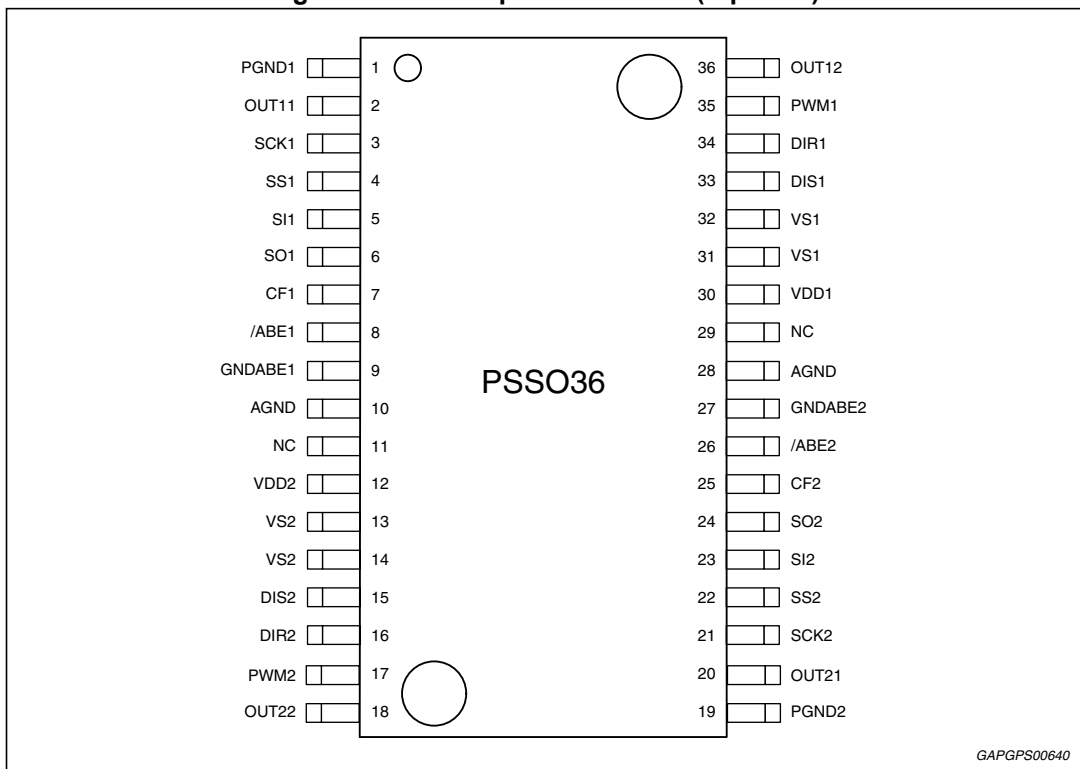
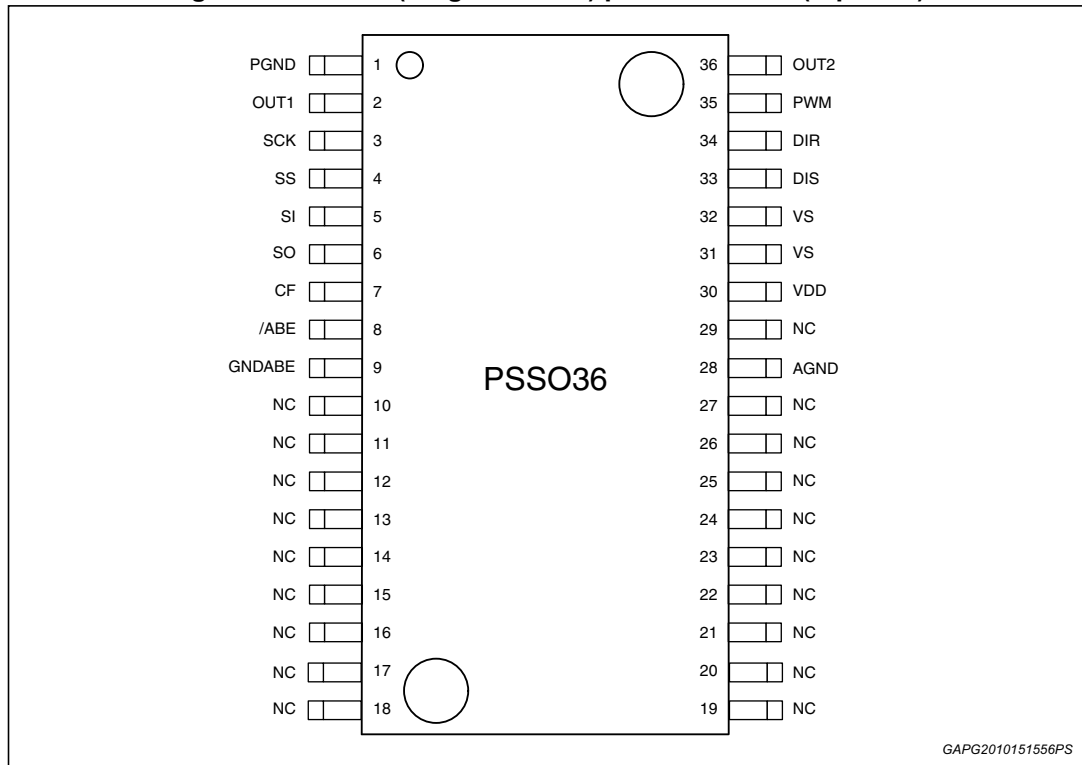

Figure 4. PSSO36 (Single version) pin connection (top view)



## 2.1 Pin definitions and functions

Table 2. L9959S PSSO24 pin-out

Pin	Symbol	Function
1, 4, 12, 13, 14, 16, 22, 24	NC	To be connected to GND on PCB.
2	PGND	Power Ground
3	OUT1	Bridge output 1 and 2: The bridge outputs are built of a high-side p-channel and a low-side N-channel transistor.
5	SCK	Serial clock input: This input controls the internal shift register of the SPI.
6	SS	Slave Select input: The serial data transfer between the device and the micro controller is enabled by pulling the input SS to low level.
7	SI	Slave in (Serial data input): The input receives serial data from the microcontroller.
8	SO	Slave Out (Serial data output): The diagnosis data is available via the SPI through this tristate-output.

Table 2. L9959S PSSO24 pin-out (continued)

Pin	Symbol	Function
9	CF	Current Proportional Feedback output: The CF pin provides in conjunction with an external resistor an output current, which is proportional to the H-Bridge current.
10	/ABE	Bidirectional Ability/Enable Pin: Open-Drain Output, which is pulled low in case of VDD over- and under-voltage. If the input is pulled to low, all output stages are switched off.
11	GNDABE	Sense Ground for VDD monitoring
15	AGND	Device Ground. (Connected to Exposed PAD)
17	VDD	VDD Supply: 5 V Supply
18	VS	Power supply voltage for power stage outputs (external reverse protection required)
19	DIS	Disable input: DIS switches OUT1 and OUT2 to tristate.
20	DIR	Direction input: The DIR pin controls the switch direction of OUT1 and OUT2.
21	PWM	PWM input: The PWM input switches OUT1 and OUT2.
23	OUT2	Bridge output 1 and 2: The bridge outputs are built of a high-side p-channel and a low-side N-channel transistor.
EP	AGND	Exposed Pad: Connected to AGND.

Table 3. L9959T (Two H-Bridge drivers in one package) PSSO36 pin-out

Pin	Symbol	Function
1	PGND1 <sup>(1)</sup>	Ground: Important: For the capability of driving the full current at the outputs, all ground pins must be externally connected.
2	OUT11	Bridge output 11, 12, 21, and 22: The bridge outputs are built of a high-side p-channel and a low-side N-channel transistor. The bridge outputs of chip 1 are OUT11 and OUT12, of chip 2 OUT21 and OUT22.
3	SCK1	Serial clock input: This input controls the internal shift register of the SPI. SCK1 belongs to chip 1 and SCK2 to chip 2.
4	SS1	Slave Select input: The serial data transfer between the device and the micro controller is enabled by pulling the input SS to low level. SS1 belongs to chip 1 and SS2 to chip 2.
5	SI1	Slave in (Serial data input): The input receives serial data from the microcontroller. SI1 belongs to chip 1 and SI2 to chip 2.
6	SO1	Slave Out (Serial data output): The diagnosis data is available via the SPI through this tristate-output. SO1 belongs to chip 1 and SO2 to chip 2.

Table 3. L9959T (Two H-Bridge drivers in one package) PSSO36 pin-out (continued)

Pin	Symbol	Function
7	CF1	Current Proportional Feedback output: The CF pin provides in conjunction with an external resistor an output current, which is proportional to the H-Bridge current. CF1 belongs to OUT11 and OUT12, CF2 to OUT21 and OUT22.
8	/ABE1	Bidirectional Ability/Enable Pin 1: Open-Drain Output, which is pulled low in case of VDD over- and under-voltage. If the input is pulled to low, all output stages are switched off. /ABE1 belongs to chip 1.
9	GNDABE1	Sense Ground for VDD monitoring
10, 28	AGND	Device Ground. (Connected to Exposed PAD)
11, 29	NC	To be connected to GND on PCB.
12	VDD2 <sup>(2)</sup>	VDD Supply: 5V Supply.
13, 14,	VS2 <sup>(3)</sup>	Power supply voltage for power stage outputs (external reverse protection required): Important: For the capability of driving the full current at the outputs all pins of VS must be externally connected.
15	DIS2	Disable input 2: DIS2 switches OUT21 and OUT22 to tristate.
16	DIR2	Direction input 2: DIR2 pin controls the switch direction of OUT21 and OUT22.
17	PWM2	PWM input 2: PWM1 input switches OUT21 and OUT22.
18	OUT22	Bridge output 11, 12, 21, and 22: The bridge outputs are built of a high-side p-channel and a low-side N-channel transistor. The bridge outputs of chip 1 are OUT11 and OUT12, of chip 2 OUT21 and OUT22.
19	PGND2 <sup>(1)</sup>	Ground: Important: For the capability of driving the full current at the outputs, all ground pins must be externally connected.
20	OUT21	Bridge output 11, 12, 21, and 22: The bridge outputs are built of a high-side p-channel and a low-side N-channel transistor. The bridge outputs of chip 1 are OUT11 and OUT12, of chip 2 OUT21 and OUT22.
21	SCK2	Serial clock input: This input controls the internal shift register of the SPI. SCK1 belongs to chip 1 and SCK2 to chip 2.
22	SS2	Slave Select input: The serial data transfer between the device and the micro controller is enabled by pulling the input SS to low level. SS1 belongs to chip 1 and SS2 to chip 2.
23	SI2	Slave in (Serial data input): The input receives serial data from the microcontroller. SI1 belongs to chip 1 and SI2 to chip 2.
24	SO2	Slave Out (Serial data output): The diagnosis data is available via the SPI through this tristate-output. SO1 belongs to chip 1 and SO2 to chip 2.

**Table 3. L9959T (Two H-Bridge drivers in one package) PSSO36 pin-out (continued)**

Pin	Symbol	Function
25	CF2	Current Proportional Feedback output: The CF pin provides in conjunction with an external resistor an output current, which is proportional to the H-Bridge current. CF1 belongs to OUT11 and OUT12, CF2 to OUT21 and OUT22.
26	/ABE2	Bidirectional Ability/Enable Pin 2: Open-Drain Output, which is pulled low in case of VDD over- and under-voltage. If the input is pulled to low, all output stages are switched off. /ABE2 belongs to chip 2.
27	GNDABE2	Sense Ground for VDD monitoring
30	VDD1 <sup>(2)</sup>	VDD Supply: 5V Supply.
31, 32	VS1 <sup>(3)</sup>	Power supply voltage for power stage outputs (external reverse protection required): Important: For the capability of driving the full current at the outputs all pins of VS must be externally connected.
33	DIS1	Disable input 1: DIS1 switches OUT11 and OUT12 to tristate
34	DIR1	Direction input 1: DIR1 pin controls the switch direction of OUT11 and OUT12.
35	PWM1	PWM input 1: PWM1 input switches OUT11 and OUT12.
36	OUT12	Bridge output 11, 12, 21, and 22: The bridge outputs are built of a high-side p-channel and a low-side N-channel transistor. The bridge outputs of chip 1 are OUT11 and OUT12, of chip 2 OUT21 and OUT22.
EP	AGND <sup>(4)</sup>	Exposed PAD: connected to AGND

1. Pins 1 is referred to die 1, whereas 19 is referred to die 2.
2. Pins 12 is referred to die 2, whereas 30 is referred to die 1.
3. Pins 13 and 14 are referred to die 2, whereas pins 31 and 32 are referred to die1.
4. Pins 10 is referred to die 2, whereas 28 is referred to die 1.

Table 4. L9959U (Single version in PSSO36) pin out

Pin	Symbol	Function
1	PGND	Ground: Important: For the capability of driving the full current at the outputs, all ground pins must be externally connected.
2	OUT1	The bridge outputs are built of a high-side p-channel and a low-side N-channel transistor.
3	SCK	Serial clock input: This input controls the internal shift register of the SPI.
7	CF	Current Proportional Feedback output: The CF pin provides in conjunction with an external resistor an output current, which is proportional to the H-Bridge current
8	/ABE	Bidirectional Ability/Enable Pin: Open-Drain Output, which is pulled low in case of VDD over- and under-voltage. If the input is pulled to low, all output stages are switched off.
9	GNDABE	Sense Ground for VDD monitoring
10,11, 12,13, 14,15, 16,17, 18,19, 20,21, 22,23, 24,25, 26,27, 29	NC	To be connected to GND on PCB.
28	AGND	Device Ground. (Connected to Exposed PAD)
30	VDD	VDD Supply: 5 V Supply.
31, 32	VS1	Power supply voltage for power stage outputs (external reverse protection required): Important: For the capability of driving the full current at the outputs all pins of VS must be externally connected.
33	DIS	Disable input : DIS switches OUT1 and OUT2 to tristate
34	DIR	Direction input: DIR pin controls the switch direction of OUT1 and OUT2.
35	PWM	PWM input: PWM input switches OUT1 and OUT2.
36	OUT2	The bridge outputs are built of a high-side p-channel and a low-side N-channel transistor.

## 3 Electrical specifications

### 3.1 Absolute maximum ratings

**Warning:** Stressing the device above the rating listed in the "Absolute maximum ratings" table may cause permanent damage to the device. These are stress ratings only and operation of the device at these or any other conditions above those indicated in the operating sections of this specification is not implied. Exposure to absolute maximum rating conditions for extended periods may affect device reliability. Refer also to the STMicroelectronics SURE program and other relevant quality document.

**Table 5. Absolute maximum ratings**

Symbol	Parameter / Test condition	Value [DC Voltage]	Unit
$V_{VS}$	DC supply voltage The device is able to sustain load dump as specified in the ISO16750 documentation	-1.0 to +40	V
$V_{VDD}$	Stabilized supply voltage, logic supply	-0.3 to 18	V
$C_F^{(1)}$	Current feedback output	-0.3 to 18	V
$V_{SI}, V_{SCK}, V_{SS}, V_{SO}, V_{DIR}, V_{PWM}, V_{DIS}$	Logic input / output voltage range	-0.3 to 18	V
$V_{OUTn}$	Output voltage (n = 1,2 or 11,12,21,22); $V_{OUTn} < V_S + 1\text{ V}$	-1.0 to 40	V
	Dynamic pulse / t < 500ms; $V_{OUTn} < V_S + 2\text{ V}$	-2.0 to 40	V
$T_j$	Operating junction temperature	-40 to 150	°C
	Dynamic junction temperature (1000hrs)	150 to 175	°C
$T_{stg}$	Storage temperature	-55 to 150	°C

1. It is withstood at  $V_S = 18\text{ V}$

### 3.2 ESD protection

**Table 6. ESD protection**

Parameter	Value	Unit
All pins versus ground group (AGND, PGND1, PGND2, GND_ABE1, GND_ABE2)	$\pm 2^{(1)}$	kV
VS pin, Power Output Pins: OUT1, OUT2 or OUT11, OUT12, OUT21, OUT22 versus ground group (AGND, PGND1, PGND2, GND_ABE1, GND_ABE2)	$\pm 4^{(2)}$	kV

1. HBM according to MIL 883C, Method 3015.7 or EIA/JESD22-A114-A.

2. HBM with all unzipped pins grounded.

### 3.3 Thermal data

Table 7. Thermal data

Symbol	Parameter	Value	Unit
$R_{thj-case}$	Thermal resistance junction-to-case (max) for L9959S, L9959T	2.0	°C/W

### 3.4 Electrical characteristics

The voltages are referred to ground and currents are assumed positive, when the current flows into the pin.  $4.5\text{ V} \leq V_S \leq 18\text{ V}$ ,  $4.5\text{ V} \leq V_{DD} \leq 5.5\text{ V}$ ; all outputs open;  $T_j = -40\text{ °C}$  to  $150\text{ °C}$ , unless otherwise specified.

Table 8. Supply

Symbol	Parameter	Test condition	Min.	Typ.	Max.	Unit
$V_S$	Operating voltage range	-	4.5	-	28	V
$I_{VS}$	$V_S$ current consumption in active mode	$V_{DD} = 5\text{ V}$ ; $V_S = 5\text{ V}$ and $V_S = 18\text{ V}$ ; Bridge disabled	-	-	5	mA
		$V_{DD} = 5\text{ V}$ ; $V_S = 5\text{ V}$ and $V_S = 18\text{ V}$ ; $f_{OUT} = 2\text{ kHz}$ ; $I_{OUT} = 0\text{ A}$	-	-	6	mA
		$V_{DD} = 5\text{ V}$ ; $V_S = 5\text{ V}$ and $V_S = 18\text{ V}$ ; $f_{OUT} = 10\text{ kHz}$ ; $I_{OUT} = 0\text{ A}$	-	-	14	mA
		$V_{DD} = 5\text{ V}$ ; $V_S = 28\text{ V}$ ; $f_{OUT} = 10\text{ kHz}$ ; $I_{OUT} = 0\text{ A}$	-	-	14	mA
$I_{VS(stby)}$	$V_S$ current consumption in passive mode	$V_{DD} = 0\text{ V}$	0	-	2.5	mA
$V_{VS\_slew}^{(1)}$	Slew rate on $V_S$	-	-	-	100	V/ $\mu$ s
$V_{VS\_slew}^{(2)}$	Slew rate on $V_S$	-	-	-	20	V/ $\mu$ s
$V_{DD}$	Operating voltage range	-	4.5	-	5.5	V
$I_{VDD}$	$V_{DD}$ supply current	$V_S = 18\text{ V}$ ; $V_{DD} = 5\text{ V}$	-	-	10	mA

1. No change of parameters for VDD-monitoring and in SPI logic
2. No change of parameters

Table 9. Power-on reset

Symbol	Parameter	Test condition	Min.	Typ.	Max.	Unit
$V_{DDRES}$	Reset active threshold	-	2.8	-	3.4	V
$V_{DDPOR}$	Power-on reset threshold	-	3.3	-	4	V
$V_{DDPORHYS}$	Power-on reset hysteresis	-	-	600	-	mV
$t_{POR}$	Power-on reset extension time	-	-	-	1	ms

Table 10.  $V_{DD}$  monitoring

Symbol	Parameter	Test condition	Min.	Typ.	Max.	Unit
$V_{DD}$	$V_{DD}$ monitoring voltage range	-	$V_{DDPOR}$	-	18	V
$V_{DD\_THL}$	Under voltage threshold	$V_S = 0\text{ V}$	4.2	-	4.5	V
$V_{DD\_THH}$	Over voltage threshold	$V_S = 0\text{ V}$	5.25	-	5.5	V
$t_{FIL\_OFF}$	Switch-off filtering time	Guaranteed by scan.	60	-	135	$\mu\text{s}$
$t_{FIL\_ON}$	Switch-on filtering time		60	-	135	$\mu\text{s}$
$V_{TEST\_THL}$	Under voltage test threshold	-	5.25	-	5.5	V
$V_{TEST\_THH}$	Over voltage test threshold	-	4.2	-	4.4	V
$V_{DD\_MR}$	Full $V_{DD}$ supply range	-	-0.3	-	18	V
$V_{DD\_SLEW}$	$V_{DD}$ slew	-	-	-	500	mV/ $\mu\text{s}$
$\Delta V_{DD\_THX}$	Threshold ( $V_{DD\_THH}$ , $V_{DD\_THL}$ ) shift during vs. inverse current	-	-0.1	-	0.1	V
$V_{ABE\_INL}$	/ABE input low-level	-	-0.3	-	1.65	V
$V_{ABE\_INH}$	/ABE input high-level	-	3.15	-	18	V
$V_{ABE\_INHYS}$	/ABE input hysteresis	-	0.2	-	1.0	V
$I_{ABE\_IN}$	/ABE input pull-down current	$0\text{ V} < V_{ABE} < 1.5\text{ V}$	0	-	60	$\mu\text{A}$
		$V_{ABE} = 2.1\text{ V}, 5\text{ V}, 18\text{ V};$ $V_S = 18\text{ V}; V_{DD} = 5\text{ V},$ $18\text{ V}$	20	40	60	$\mu\text{A}$
$V_{ABE\_OUTL}$	/ABE output low voltage	$2.5\text{ V} < V_{DD} < V_{DD\_THL};$ $I_{ABE\_OUTL} < 2.5\text{ mA}$	0	-	1.0	V
$V_{ABE\_OUTL}$	/ABE output low voltage	$V_{DD\_THH} < V_{DD} < 18\text{V};$ $I_{ABE\_OUTL} < 7.5\text{ mA}$	0	-	1.2	V
$V_{ABE\_OUTL}$	/ABE output passive low voltage	-	0	-	1.2	V
$\Delta I_{ABE}$	$I_{ABE}$ Change during vs. inverse current	-	-100	-	100	$\mu\text{A}$

Table 11. Undervoltage shutdown

Symbol	Parameter	Test condition	Min.	Typ.	Max.	Unit
V <sub>UV_OFF</sub>	VS UV threshold	VS decreasing	3.1	3.8	4.5	V
V <sub>UV_ON</sub>	VS UV threshold	VS increasing	3.3	4.0	4.7	V
V <sub>UV_HYS</sub>	VS UV hysteresis	V <sub>UV_ON</sub> - V <sub>UV_OFF</sub>	0.1	-	1	V
t <sub>FUV</sub>	VS UV detection time	-	-	-	1.5	µs

### 3.5 Outputs OUT1 and OUT2

Table 12. On-resistance (4.5 V < V<sub>S</sub> < 28 V)

Symbol	Parameter	Test condition	Min.	Typ.	Max.	Unit
r <sub>ONVS</sub> OUT1,2	On-resistance to supply	V <sub>DD</sub> = 5 V; V <sub>S</sub> = 10 V, I <sub>OUT1,2</sub> = 3 A	-	-	315	mΩ
r <sub>ONGND</sub> OUT1,2	On-resistance to PGND	V <sub>DD</sub> = 5 V; V <sub>S</sub> = 10 V, I <sub>OUT1,2</sub> = 3 A	-	-	225	mΩ
I <sub>LEAK</sub>	Switched-off output current of OUT1,2	V <sub>DD</sub> = 5 V; V <sub>S</sub> = 13 V; V <sub>OUT</sub> = 0 V	-200	-	-	µA
		V <sub>DD</sub> = 5 V; V <sub>S</sub> = 13 V; V <sub>OUT</sub> = V <sub>S</sub>	-	-	200	µA

Table 13. Power output switching times (8 V < V<sub>S</sub> < 18 V)

Symbol	Parameter	Test condition	Min.	Typ.	Max.	Unit
t <sub>d ON</sub>	Output delay time driver on	-	-	-	6	µs
t <sub>d OFF</sub>	Output delay time driver off	-	-	-	20	µs
t <sub>d dis</sub> <sup>(1)</sup>	Disable delay time	Guaranteed through scan.	-	-	12.5	µs
t <sub>d pwon</sub>	Power-on delay time		-	-	1	ms
t <sub>d en</sub>	Enable delay time		-	-	50	µs
dl <sub>OUT</sub> /dt	Current slew rate	-	-	1.6		A/µs
dV <sub>OUTHS</sub> /dt <sub>(2)</sub>	Output rise/fall slew-rate high-side slow selected with bit SR = 0 fast selected with bit SR = 1	V <sub>DD</sub> = 5 V; V <sub>S</sub> = 14 V R <sub>LOAD1,2</sub> = 2.6 Ω (8 V <sub>S</sub> ), 6 Ω (18 V <sub>S</sub> )	0.975 2.8	-	2.7 8	V/µs
dV <sub>fOUTLS</sub> /dt <sub>(2)</sub>	Output rise slew-rate low-side valid only after the toggling of DIR input		0.975	-	2.7	V/µs
dV <sub>fOUTLS</sub> /dt <sub>(2)</sub>	Output fall slew-rate low-side		2.5	4	8	V/µs
f <sub>pwmmax</sub>	PWM input frequency	-	-	-	11	kHz

1. Driven by /ABE or DIS input.

2. The slew-rates (dV<sub>OUT</sub>/dt1) are defined by dV (voltage difference 20% - 80%) divided by the rise-/fall times (t<sub>r</sub>/t<sub>f</sub> see [Figure 6: Output rise and fall times](#)).

Figure 5. Output delay times (e.g. low-side output)

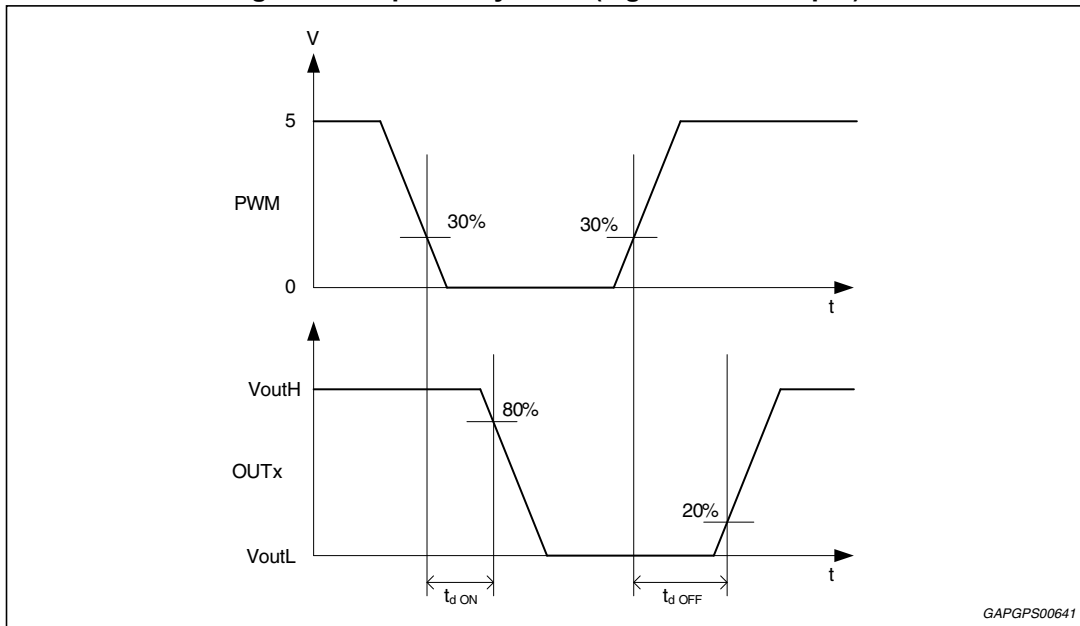

Figure 6. Output rise and fall times

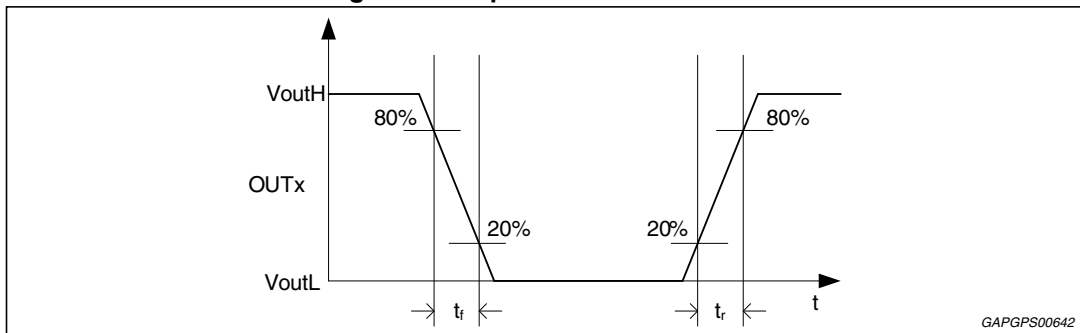

Figure 7. Output disable and enable time (/ABE Input)

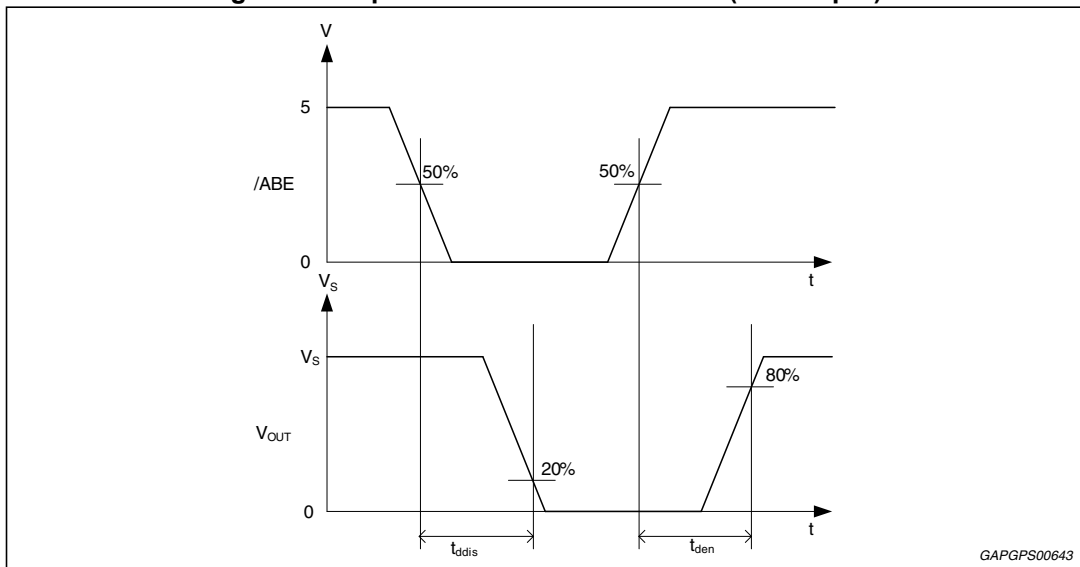
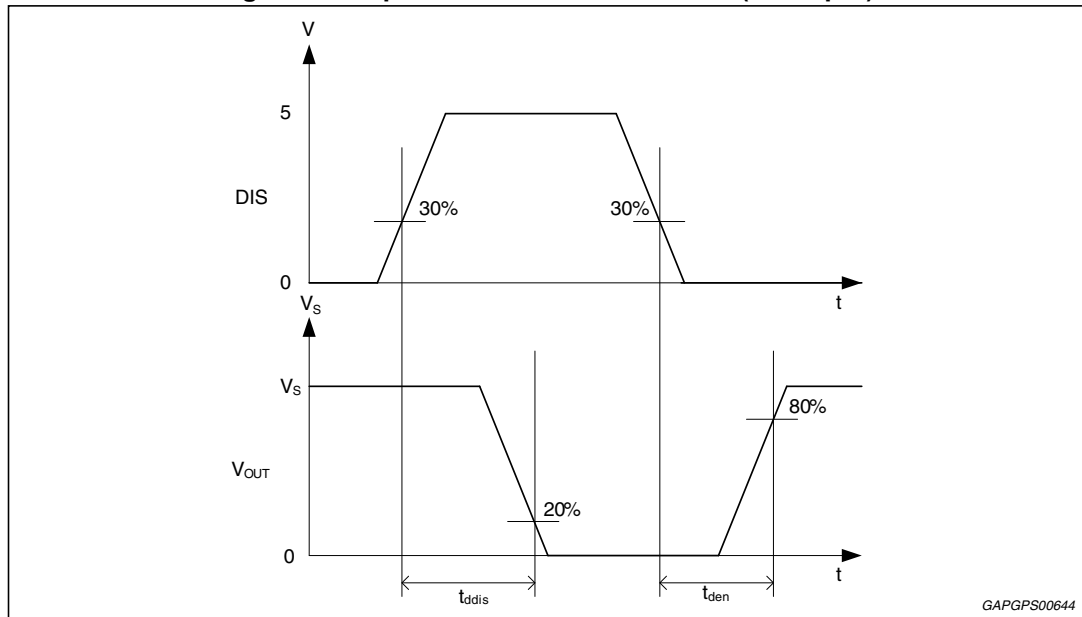

Figure 8. Output disable and enable time (DIS Input)



GAPGPS00644

Table 14. Current feedback (CF)

Symbol	Parameter	Test condition	Min.	Typ.	Max.	Unit
V <sub>CF</sub> <sup>(1)</sup>	CF voltage range	V <sub>S</sub> > 6.5 V, OUTx = 0 A, T <sub>J</sub> = -40 °C; Current level 2,3,4	0.01	0.05	0.20	V
		V <sub>S</sub> > 6.5 V, OUTx = 250mA, T <sub>J</sub> = 130 °C; Current level 2,3,4	0.04	0.275	0.5	V
		V <sub>S</sub> > 6.5 V, OUTx = 0.4 * I <sub>clx</sub> , T <sub>J</sub> = 130 °C; Current level 2,3,4	1.71	1.80	1.89	V
		V <sub>S</sub> > 6.5 V, OUTx = I <sub>clx</sub> , T <sub>J</sub> = -40 °C to 150 °C; Current level 2,3,4	3.82	4.5	5.18	V
R <sub>CF</sub> <sup>(2)</sup>	CF resistor range	-	5.1	-	kΩ	
I <sub>OFFSET</sub>	CF offset current	-	10	-	μA	

1. Measured at a 5.1k resistor between CF and GND (R<sub>CF</sub>). Levels see [Table 34](#) Current Level (CONFIG\_REG).

2. Defined by design, not tested.

Note: This signal has an individual error ±5 % in each of the three currents levels, at trimming temperature of 130 °C. Additional an individual error ±10 % in each of the three current levels over temperature and aging. So the maximum error is of ±15 % in each of the three current levels. The offset and the gain errors may be different in each current level. The adjustment is done at 130 °C and compensates the error corresponding to 0.4 \* I<sub>clx</sub>

Table 15. Current limiting

Symbol	Parameter	Test condition	Min.	Typ.	Max.	Unit
$ I_{CL2} ^{(1)}$	Current limit <sub>2</sub>	$R_{CF} = 5.1 \text{ k}\Omega$	4.25	5	5.75	A
$ I_{CL3} ^{(1)}$	Current limit <sub>3</sub>		5.6	6.6	7.6	A
$ I_{CL4} ^{(1)}$	Current limit <sub>4</sub>		7.3	8.6	9.9	A
$ I_{HYS2-4} ^{(1)}$	Current limit hysteresis <sub>1</sub>	-	-5% $I_{CL2-4}$	-	-10% $I_{CL2-4}$	A
$t_b$	Blanking time	Guaranteed through scan.	8	11	15	$\mu\text{s}$
$t_{trans}$	Time between two transient		90	-	130	$\mu\text{s}$

1. Programmable current levels see [Table 34](#) Current Level (CONFIG\_REG). Measured using a 5.1 k $\Omega$  resistor between CF and GND ( $R_{CF}$ ).

Table 16. Over-current detection ( $8 \text{ V} < V_S < 18 \text{ V}$ )

Symbol	Parameter	Test condition	Min.	Typ.	Max.	Unit
$ I_{OC2\_LS} ^{(1)}$	Low side over current threshold <sub>2</sub>	$V_{DD} = 5 \text{ V}$	4.9	-	8.2	A
$ I_{OC3\_LS} ^{(1)}$	Low side over current threshold <sub>3</sub>	$V_{DD} = 5 \text{ V}$	6.7	-	11.1	A
$ I_{OC4\_LS} ^{(1)}$	Low side over current threshold <sub>4</sub>	$V_{DD} = 5 \text{ V}$	8.4	-	14	A
$ I_{OC2\_HS} ^{(1)}$	High side over current threshold <sub>2</sub>	$V_{DD} = 5 \text{ V}$	5.5	-	9.2	A
$ I_{OC3\_HS} ^{(1)}$	High side over current threshold <sub>3</sub>	$V_{DD} = 5 \text{ V}$	6.9	-	11.5	A
$ I_{OC4\_HS} ^{(1)}$	High side over current threshold <sub>4</sub>	$V_{DD} = 5 \text{ V}$	8.6	-	14.4	A
$I_{TRACK-2}^{(2)}$	$ I_{OC2}  -  I_{CL2} $	$V_{DD} = 5 \text{ V}$	0.4	-	5.5	A
$I_{TRACK-3}^{(2)}$	$ I_{OC3}  -  I_{CL3} $	$V_{DD} = 5 \text{ V}$	0.4	-	5.5	A
$I_{TRACK-4}^{(2)}$	$ I_{OC4}  -  I_{CL4} $	$V_{DD} = 5 \text{ V}$	0.4	-	5.5	A
$t_{DF}$	Delay time for fault detection	guaranteed by design	1	2	4.5	$\mu\text{s}$
$t_{DF\_off}$	Switch-off delay time	-			6	$\mu\text{s}$
$t_{DF\_del}$	Delayed switch-off time	-	20		200	$\mu\text{s}$
$t_{SC}$	Short-circuit detection	guaranteed through scan	292	350	413	$\mu\text{s}$

1. Programmable current levels see [Table 34](#) Current Level (CONFIG\_REG).
2. Tracking values are referred for both LS and HS.

Table 17. Open-load detection

Symbol	Parameter	Test condition	Min.	Typ.	Max.	Unit
$R_{OL}$	Open-load detection threshold	-	5	-	50	k $\Omega$
$t_{DIAGOL}$	Open-load diagnosis enable delay	Guaranteed through scan.	100	-	150	ms
$t_{DIAGOL1}$	Open-load diagnosis filter time <sub>1</sub>		2.4	-	3.6	ms
$t_{DIAGOL2}$	Open-load diagnosis filter time <sub>2</sub>		200	-	300	$\mu$ s
$V_{out1\_OFF}$	Out1 voltage regulator	-	1.67	-	1.97	V

Note: If the value of the connected load is below 5 k $\Omega$  no Open Load is detected; whereas if the value of the connected load is more than 50 k $\Omega$ , Open Load is detected. If the load is in the range between (5 to 50) k $\Omega$ , the Open Load diagnosis could be not reliable.

Table 18. Retest delay

Symbol	Parameter	Test condition	Min.	Typ.	Max.	Unit
$t_{delay\ retest}$	Retest delay for failures: SCB, SCG, SCL	Guaranteed through scan.	290	350	410	$\mu$ s

### 3.6 Temperature dependent current reduction

Table 19. Temperature dependent current reduction

Symbol	Parameter	Test condition	Min.	Typ.	Max.	Unit
$ I_{L\_TSD} $	Current limit at $T_{SD}$	-	1.4	2.5	3.6	A
$T_{ILR}$	Start of temperature dependent current reduction	-	150	165	-	$^{\circ}$ C
$T_{SD}$	Thermal shut-down	-	175	-	-	$^{\circ}$ C
$T_{SD}-T_{ILR}$	Range of temperature dependent current reduction	-	20	25	30	$^{\circ}$ C
$T_{fTSD}$	Thermo-shut-down detection filter time	Guaranteed through scan.	6	-	18	$\mu$ s

Note: see also [Figure 17: Temperature dependent current reduction](#).

### 3.7 Free-wheeling diodes

Table 20. Free-wheel diodes

Symbol	Parameter	Test condition	Min.	Typ.	Max.	Unit
$U_D$	Free-wheeling diode forward voltage	$I_{OUT} = 3\text{ A}$	-	-	2	V
$T_{it}^{(1)}$	Free-wheeling diode reverse recovery time	-	-	-	100	ns

1. Not subject to production test; specified by design.

### 3.8 SPI / logic electrical characteristics

The voltages are referred to ground and currents are assumed positive, when the current flows into the pin.  $4.5\text{ V} \leq V_S \leq 18\text{ V}$ ,  $4.5\text{ V} \leq V_{CC} \leq 5.5\text{ V}$ ; all outputs open;  $T_j = -40\text{ }^\circ\text{C}$  to  $150\text{ }^\circ\text{C}$ , unless otherwise specified.

**Table 21. Inputs: SI, SS, SCK, DIR, DIS and PWM; Output: SO**

Symbol	Parameter	Test condition	Min	Typ	Max	Unit
<b>Inputs: SI, SS, SCK DIR, PWM</b>						
$V_{IL}$	Input voltage low-level	$V_{DD} = 5\text{ V}$	-0.3	-	0.75	V
$V_{IH}$	Input voltage high-level	$V_{DD} = 5\text{ V}$	1.75	-	$V_{DD}+0.3$	V
$V_{IHYS}$	Input hysteresis	$V_{DD} = 5\text{ V}$	0.2	-	1.0	V
$R_{PUIin}$	Input pull-up resistor	$V_{DD} = 5\text{ V}$	50	-	250	k $\Omega$
$I_{INx}$	PWM, DIR input current	$V_{INx} > 3.0\text{V}$	-5	-	5	$\mu\text{A}$
$C_{Slin}^{(1)}$	SI input capacitance	-	-	-	10	pF
$C_{SCKin}^{(1)}$	SCK input capacitance	-	-	-	10	pF
$C_{SSin}^{(1)}$	SS Input Capacitance	-	-	-	15	pF
$C_{DIR,PWMIn}^{(1)}$	DIR, PWM input capacitance	-	-	-	20	pF
<b>Input: DIS</b>						
$R_{DISPU}$	Pull-up resistor	$0\text{ V} < V_{DIS} < 2.1\text{ V}$	10	-	45	k $\Omega$
$I_{DISx}$	DIS input current	$V_{DIS} > 3\text{ V}$	-5	-	5	$\mu\text{A}$
$C_{DISin}^{(1)}$	DIS input capacitance	-	-	-	20	pF
$t_{DIS}$	DIS pulse width	-	0.5	1	1.5	$\mu\text{s}$
<b>Input pin disturbance (SI, SS, SCK DIR, PWM,DIS)</b>						
$\Delta V_{x\_HL}$	Change of $V_{IH}$ and $V_{IL}$ during inverse current on $V_S$	Not subjected to test in production.	-0.1	-	0.1	V
$\Delta I_{Sx}$	Change of input current of SPI input pins during inverse current on $V_S$		-100	-	100	$\mu\text{A}$
<b>Output: SO</b>						
$V_{SOL}$	Output voltage low level	$I_{OL} = 2\text{ mA}$ ,	0	-	0.4	V
$V_{SOH}$	Output voltage high level	$I_{OH} = -2\text{ mA}$	$V_{DD}-0.5$	-	$V_{DD}$	V
$SR_{SO}^{(1)}$	Slew rate	$C_{LOAD} = 200\text{ pF}$	0.3	-	0.6	V/ns
$I_{SOLK}$	Tristate leakage current	$V_{SS} = V_{DD}$	-10	-	10	$\mu\text{A}$
$C_{SOout}^{(1)}$	SO output capacitance	-	-	-	10	pF
<b>Output pin disturbance (SO)</b>						
$\Delta I_{SOLK}$	Change of $I_{SOLK}$ during inverse Current on $V_S$	-	-100	-	100	$\mu\text{A}$

1. Not measured in production test. Parameter guaranteed by design.

Table 22. Dynamic characteristics

Symbol	Parameter	Test condition	Min.	Typ.	Max.	Unit
$t_{cyc}$	Cycle time	-	490	-	-	ns
$t_{lead}$	Enable lead time	-	300	-	-	ns
$t_{lag}$	Enable lag time	-	150	-	-	ns
$t_v$	Data valid	SCK = 2 V; SO = 0.2 V; $C_L = 40$ pF	40	-	-	ns
		SCK = 2 V; SO = 0.2 V; $C_L = 200$ pF	150	-	-	ns
		SCK = 2 V; SO = 0.2 V; $C_L = 350$ pF	230	-	-	ns
$t_{su}$	Data setup time	-	40	-	-	ns
$t_h$	Data hold time	-	40	-	-	ns
$t_{dis}$	Disable time	-	0	-	100	ns
$t_{dt}$	Transfer delay	-	300	-	-	ns
$t_{dld}$	Disable lead time	-	250	-	-	ns
$t_{dlg}$	Disable lag time	-	250	-	-	ns
$t_{acc}$	Access time	-	8.35	-	-	$\mu$ s

Figure 9. SPI timing information

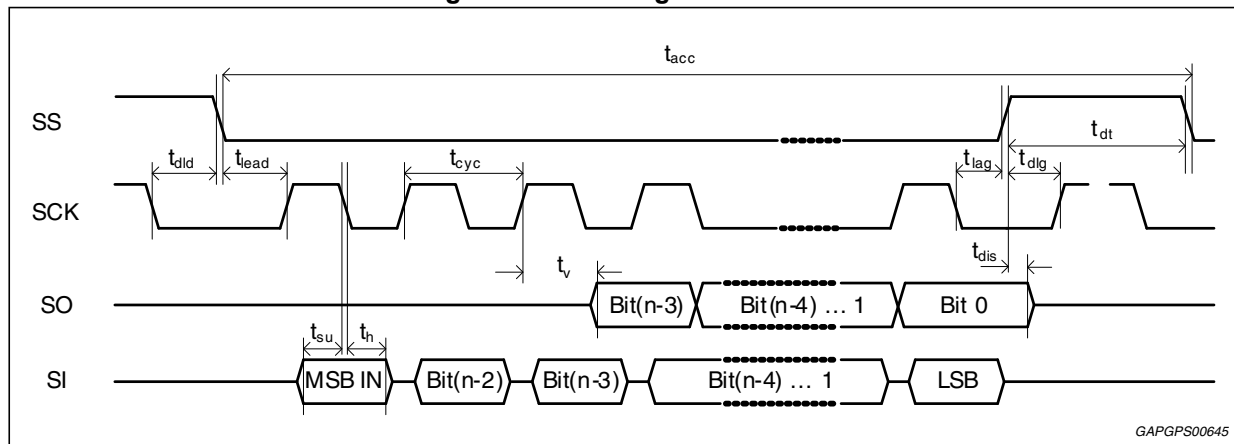

## 4 Application information

### 4.1 Power stage switching behavior

The L9959 output stages can either be controlled by the pins PWM and DIR or by their corresponding SPI registers (SPWM and SDIR: see [Table 33](#) in Configuration Register (CONFIG\_REG)). The SPI bit MUX in the configuration register (CONFIG\_REG) is used to define the driving control strategy of the H-bridge. If the power stages are disabled by /ABE or DIS, this bit is reset and the pins PWM and DIR control the outputs.

The active free-wheeling, in which the body diode is actively shorted by its associated Power-MOS, can be disabled by the bit **FW** in the configuration register (CONFIG\_REG). By default, active free-wheeling is enabled.

The device minimizes electro-magnetic emission by switching the high-side and low-side drivers in a special sequence. Two cases are distinguished: The PWM-mode, during which the current direction does not change and the direction switches using the DIR, which changes the current direction (see [Figure 10](#), [Figure 12](#) and [Figure 13](#)).

#### 4.1.1 PWM mode (same current direction)

The PWM input pin switches the high-/low-side output of the half-bridge, which is selected by the DIR pin.

DIR = '0': OUT1 is switched, DIR = '1': OUT2 is switched.

PWM = '0': Switched low-side is on, PWM = '1': Switched high-side is on.

Figure 10. PWM mode current flow

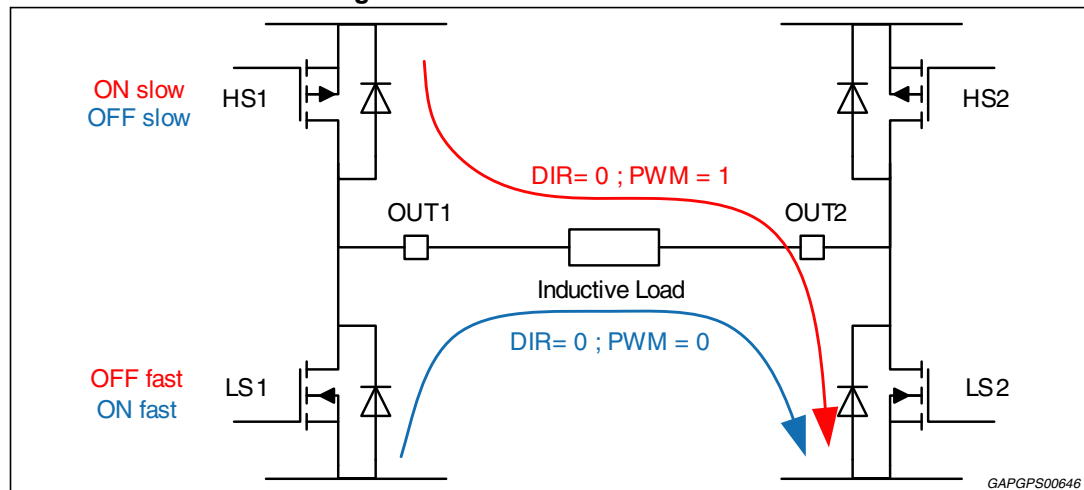
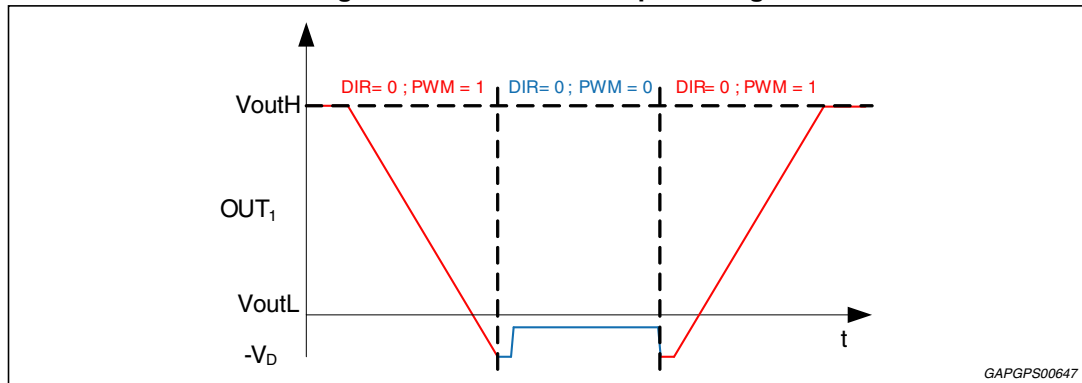

Figure 11. PWM mode output voltage



During PWM mode the high-side (e.g. *Figure 10* HS1) output is switched off with a slow slew rate until it is off and the low-side body-diode has taken over the entire current (passive freewheeling). Then the associated low-side transistor (e.g. *Figure 10* LS1) is turned on with a fast slope to reduce the voltage across the device and to minimize the power.

The output is pulled to high voltage, by first turning off the low-side driver with a fast slew rate and, after it is off, the high-side driver is switched on by a slow one (e.g. *Figure 10* LS1, HS1).

This assures, that the voltage and current change over the body diode is done smoothly, reducing the electromagnetic emission.

### 4.1.2 DIR-change mode

The first part of the sequence is identical to the PWM-mode (s.a.). After this has been finished and the associated low-side driver is on (e.g. *Figure 12* LS1), in phase 1 the other low-side driver is turned on (e.g. *Figure 12* LS2) to enter passive freewheeling phase. Then in phase 2 the low-side output of OUT2 is switched-off slowly and the current through the load is taken over by the body-diode of the high-side (e.g. *Figure 13* HS2).

Depending on the inductance of the load, the current vanishes more or less quickly. After the low-side driver is turned off, the high-side is switched on with a slow slew-rate.

This assures, that direction switch occurs while the current over the load has vanished, which reduces the electromagnetic emission.

Figure 12. DIR-change (current is changing its direction)

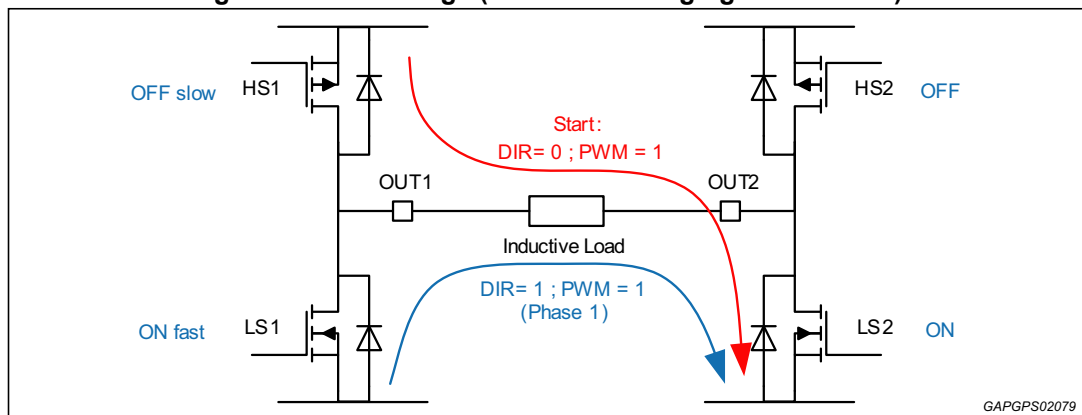

Figure 13. DIR-change current flow phase 2

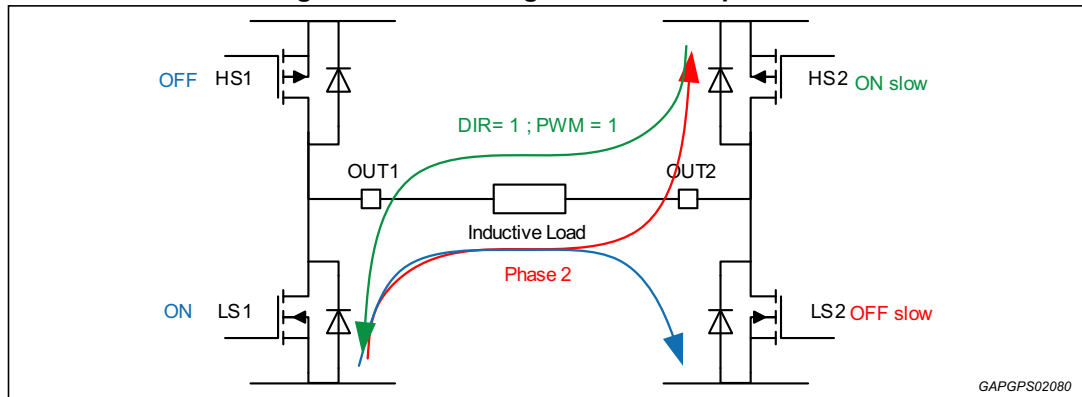
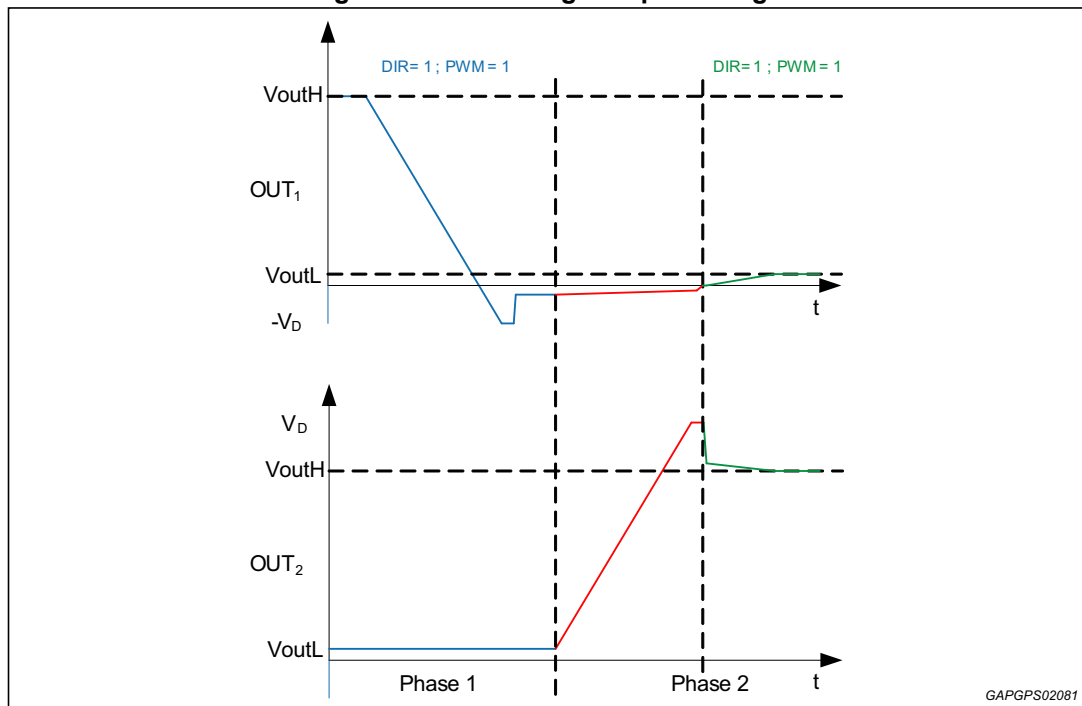

Figure 14. DIR-change output voltage



## 4.2 Protection and monitoring

A set of failure as Short-circuit to Ground (SCG), Short-circuit to battery (SCB) and Short-circuit to load (SCL) errors (SBC, SCG, SCL) are confirmed after their occurrence by accessing the error condition after time  $t_{\text{delay\_retest}}$  a second time. Only after the error is confirmed, it is entered into the diagnosis register 1 (DIA\_REG1), and the device is disabled and no further diagnosis is run.

The device can be enabled again by the following actions: Power-on reset, disabling and enabling the device using the pins /ABE or DIS (e.g. disabling - enabling sequence). The diagnosis registers can be cleared by sending a reset command by SPI (**STATCON\_REG**) to either diagnosis register 1 (**DIA\_REG1**) or 2 (**DIA\_REG2**). The bit1 (Reset) of the CONFIG\_REG if forced to zero resets both the device registers configuration and diagnosis registers to default but is not able to restart the device. In order to restart IC it is necessary

to force a transition **LOW/HIGH/LOW** on DIS pin or a transition **HIGH/LOW/HIGH** on /ABE pin.

The errors in the diagnosis register 1 (DIA\_REG1) are transferred to the diagnosis register 2 by setting the bit DIACLR1 in the status and configuration register (STATCON\_REG) or by using the enabling -disabling sequence on /ABE or DIS. This will also clear the diagnosis register 1.

### 4.2.1 Current feedback

A feedback current signal is provided at pin CF (Current Feedback). This current is proportional to the current in the H-Bridge, but does not change its direction. It is measured in the low-side transistor, which is not switched by PWM. This is determined by the input DIR or the SDIR register respectively. Therefore, the direction of the current can be seen from this direction signal.

One current sense monitoring circuit is present and it is connected to the output of the active LS driver (DIR change mode).

After the DIR transition, the LSx reference output is switched only in the phase in which both LS drivers are active for recirculation.

In the time-frame between HS turn-off and the start of active freewheeling, (including dead time and passive freewheeling), the current sense monitors the current flowing in the previous active LS driver.

This time-frame is not fixed but adaptative to real operative conditions (battery and selected slew rate mode).

In *Table 14: Current feedback (CF)* the CF behavior over an external resistor of 5.1k Ohm is specified. The current out of CF consists of a static offset current and a current proportional to the current in the select low-side transistor. The voltage at pin CF scales with the resistor at this pin.

**Figure 15. Current feedback and current limiting**

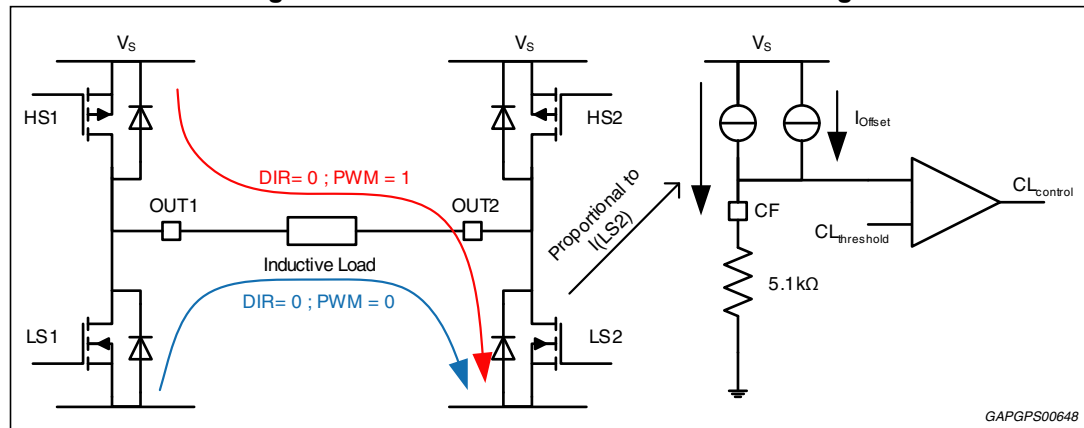

*Figure 15* Current Feedback and Current Limiting shows the current feedback in case the OUT1 is controlled by PWM (DIR = 0). In this case, the current is measured through low-side 2. If the direction is inverted, the current is measured through low-side 1.

### 4.2.2 Current limitation

The H-Bridge output current can be limited to three different values (see [Table 15: Current limiting](#)). If the current reaches the current limiting threshold  $I_{CL}$ , the output driver is switched off after the blanking time  $t_b$ , and switched on again after the current dropped below the lower current limit hysteresis threshold ( $I_{CL} - I_{HYS}$ ). The current limiting thresholds can be adjusted using the resistor at pin CF. The values in [Table 15](#) refer to a 5.1k Ohm external resistor. The current limiting threshold can be calculated by  $(4.5V/R_{CF} - I_{OFFSET}) * (I_{CLx} * 5.1k/4.45V)$  from [Table 15](#) and  $I_{OFFSET} = 10\mu A$  (typical).  $R_{CF}$  is the resistor used at pin CF.

The overcurrent threshold is not changed by RCF (see [Table 16](#)). The current limitation is active as long as the output driver is switched on. The information that the device is in current limitation is stored in the diagnosis register 2 (**DIA\_REG2**).

Figure 16. Current limitation

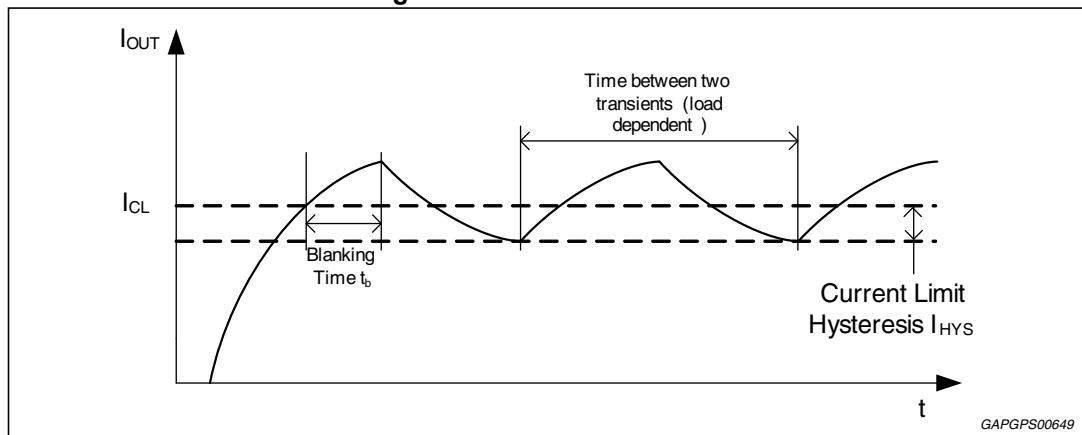

### 4.2.3 Temperature dependent current reduction

If the device reaches the temperature **TILR**, the current will be reduced (see [Figure 17: Temperature dependent current reduction](#)). If the temperature reaches the temperature shutdown threshold **TSD**, the outputs are switched off. The current limitation information is written into the diagnosis register 2 (**DIA\_REG2**).

Figure 17. Temperature dependent current reduction

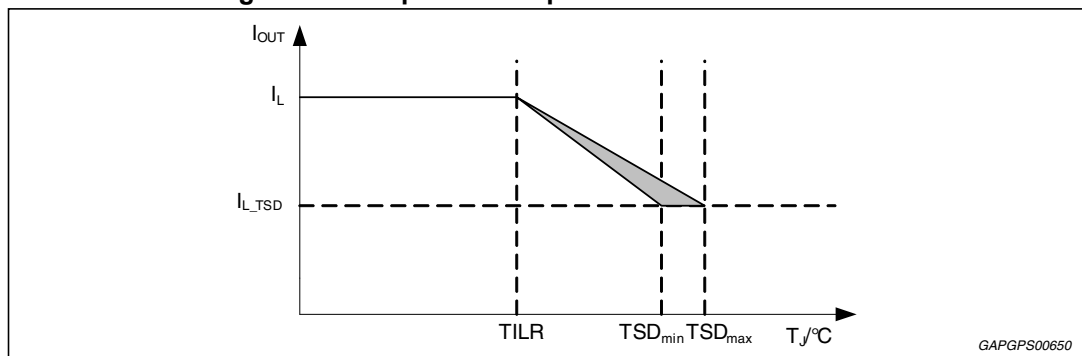

### 4.2.4 Short to battery (SCB) and short to Ground (SCG)

While the power stages are on, the current through them is monitored. If the output current reaches the current limit  $I_L$ , the output is switched off after the blanking time  $t_b$ . In case the current reaches the limit  $I_{OC}$  during this time, a short to battery (SCB) on low-sides or a short to ground (SCG) on high-sides is diagnosed, and the affected output driver is switched off immediately, the not affected one after the time  $t_{DF\_del}$ .

In order to confirm this error, the outputs are turned on again. If the error is detected for the second time, it is confirmed but it is still not possible to determine to which of the following types belongs to:

- SCB and SCL
- SCG and SCL

To discriminate the fault type, it is necessary to turn outputs on for the third time, and in case the fault is detected, the diagnosis register (DIA\_REG1) is updated consequently and the device is disabled. Otherwise, the SCG and SCB faults are confirmed only.

Figure 18. Current limiting and short circuit

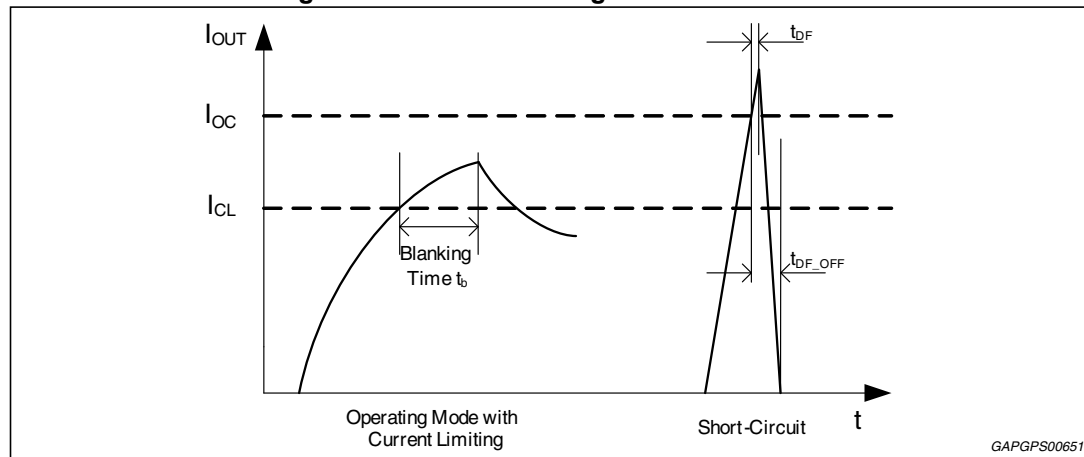

The three different over-current limits are related to the programmable current limitation, which can be programmed into the SPI register ([Table 33: Configuration register \(CONFIG\\_REG\)](#)). The over-current limits are independent of the resistor at pin CF.

*Note:* SCG: Fault Detection works correctly if the following condition is respected:  $Duty (switch\ on\ time) > T_{don} + Slew\ rate + t_{DF}$ .

### 4.2.5 Short circuit over load (SCL)

Short circuit over load (SCL) is diagnosed by a retest sequence after a short to battery (SCB) or a short to ground (SCG) has been detected and confirmed by a retry on the switched-on high-side and low-side driver. Then after the time  $t_{retest}$ , the opposite driver is switched off (i.e. the high-side in case of a short to battery on the low-side and vice versa). If the failure then disappears, a short over load (SCL) is detected.

The error is only entered into the diagnosis register and the device is disabled, if it is confirmed.

### 4.2.6 Open load (OL)

Open load can either be detected in active mode or while the output drivers are in a tri-state condition, disabled by DIS or /ABE. Open load in active mode is enabled by setting the **OLDA** in the configuration register (CONFIG\_REG).

#### Open load in active mode

With OLDA = '1', the open load condition can only be diagnosed if an inductive load is used. In normal operation, the output free wheels via the built-in diodes below ground, if the high-side output driver is switched-off. If the output does not go below ground, an open load is detected. It is possible to enable the filter OLDAFILTER by setting the dedicated bit 4 in SPECIAL\_REG (0 or 40ms). With OLDAFILTER = '1', the open-load will be recheck at the next PWM cycle and if detected again, the failure will be confirmed in DIAG\_REG1 (and latched).

In case OLDAFILTER is set at '0' (40ms) the recheck will be executed after the filter time expiration and next PWM pulse. If detected again, the failure will be confirmed (and latched).

*Note: For Open-load in active mode L9959 works properly in case the duration of the transient conditions is less than 40msec (Transient condition: function of starting current, ending current, load electrical parameters, DC MOTOR mechanical characteristics...).*

#### Open load in inactive mode

In inactive mode the open load is independent from the OLDAFILTER status (don't care condition) and it is detected by applying a pull-down current ( $I_{PD}$ ) to both outputs.

A pull-up current is generated at one output to compensate these two output currents.

If the pull-up current is in the range of one pull-down current, an open load is diagnosed.

If the load is connected, the pull up current is in the range of the sum of both pull-down currents.

An open load is detected, if the load resistance is above the open load resistance threshold; no open load is detected, if it is below this threshold ( $R_{OL}$ ).

After the outputs are disabled, it takes the time  $t_{DIAGOL}$  until the open load diagnostic can be enabled. The open load settling time to reach the correct pull up current is  $t_{diagOL1}$ , the open load filter time is  $t_{diagOL2}$ .

### 4.3 VS-undervoltage

VS is monitored for under-voltage. If VS goes below the VS-undervoltage threshold, the outputs are switched to tristate after the time  $t_{FUV}$ .

### 4.4 Inverse current at $V_S$

An inverse current of maximum 5 A, which decreases during a period of max 250 ms out of the device at VS does not lead to any destruction. After the exposure to such an inverse current the device returns to the specified functionality.

## 4.5 /ABE pin

/ABE (Ability/Enable) is a bidirectional pin, with an open-drain output. In normal operating condition, this pin is pulled up by an external resistor. If /ABE is set to low, the outputs enter tristate mode.

/ABE can be used to switch off the outputs quickly by an external signal. It is possible to connect the /ABE pins of several devices together, so all of them can be disabled in case one detects an error, which is flagged by the /ABE pin.

## 4.6 VDD-monitor

$V_{DD}$  is monitored for under- and over-voltage referenced to  $GND_{ABE}$ .

If  $V_{DD}$  goes below  $V_{DD\_THL}$  or above  $V_{DD\_THH}$ , /ABE is pulled to low and the outputs enter tristate mode after the time  $t_{FIL\_OFF}$ . The VDD-monitoring state is stored into the status and control register (STACON\_REG).

If VDD increases above  $V_{DD\_THL}$ , /ABE is pulled to high after the filter time  $t_{FIL\_ON}$ . The SPI remains functional as long as  $V_{DD}$  is above the power-on reset threshold.

The behavior of the pin /ABE and the output stages after VDD goes below  $V_{DD\_THH}$  from VDD-over-voltage is determined by bit CONFIG 0 in the status and configuration register (STATCON):

CONFIG0 = 1: /ABE is latched and the outputs remain in tristate

CONFIG0 = 0: /ABE goes to inactive and the output stages are enabled after the filtering time  $t_{FIL\_ON}$ .

## 4.7 VDD-monitor test

VDD-Monitor blocks can be tested in the application via SPI. During this test, the output stages are still switched off in case of over- and under-voltage.

### Upper threshold

The over-voltage threshold can be reduced using the configuration registers 1 and 2 (CONFIG1 and CONFIG2) in the status and control register (STACON\_REG) to  $V_{TEST\_THH}$  (see [Table 35: Status and configuration register \(STATCON\\_REG\)](#)). Since  $V_{TEST\_THH}$  is below the normal VDD voltage, the status bit STATUS0 shows a VDD over-voltage.

### Lower threshold

The under-voltage threshold can be increased to  $V_{TEST\_THL}$  using CONFIG1 and CONFIG2 in the STATCON register. Since the VDD voltage is below  $V_{TEST\_THL}$ , the resulting VDD-undervoltage resets STATUS0.

After leaving the VDD-monitor test mode, the bits in the STACON register return to their normal state.

## 4.8 Power-on reset

At power-on, while VDD increases, the internal registers are cleared and the outputs are set to tristate at the reset-active voltage  $V_{DDRES}$ . Above the power-on reset threshold  $V_{DDPOR}$  the device starts to operate after the time  $t_{POR}$ . If VDD drops below  $V_{DDPOR}$ , the device enters its reset state, i.e. all internal registers are cleared and the outputs are set to tristate.

**Table 23. Device states with respect to supply voltage**

$V_S$ [V]	$V_{DD}$ [V]	Functional state
28 – 40	0 – 18	No damage to the device, no functional behavior guaranteed
4.5 – 6.5	4.5 – 5.5	Device functional, Current Feedback accuracy reduced
6.5 – 28	4.5 – 5.5	Device functional
4.5 – 28	4.0 – 4.5 5.5 - 18	Device functional, but power-outputs tristate by $V_{DD}$ -monitor, /ABE pulled to low, SPI functional
0 – 4.5 4.5 – 28	$V_{DDPOR}$ – 4.5	Device in reset mode, SPI functional, power-outputs tristate, /ABE pulled to low
0 – 4.5 4.5 – 28	2.5 - $V_{DDPOR}$	Device in reset mode, SPI reset, power-outputs tristate, /ABE tristate
0 – 4.5	4.5 – 5.5	Device functional, outputs are tristate by $V_S$ -undervoltage
0 – 4.5	4.0 – 4.5 5.5 - 18	Device functional, outputs are tristate by $V_S$ -undervoltage and $V_{DD}$ -monitor, /ABE pulled to low

*Note:* All voltages are nominal. Please refer to [Section 3: Electrical specifications](#) for their specified values.

## 5 SPI functional description

### 5.1 General description

The SPI communication is based on a Serial Peripheral Interface structure using SS (SPI Select), SI (Serial Data In), SO (Serial Data Out) and SCK (Serial Clock) signal lines. The first data at pin SI is latched into the device with the first falling edge of the clock SCK after the clock has changed from low to high, which is the second edge after SPI-Select has been pulled to low.

#### 5.1.1 SPI select (SS)

The SS input pin is used to select the serial interface of this device. When SS is high, the output pin (SO) is in high impedance state. A low signal starts the serial communication. A communication frame is the time between the falling edge of SS and its rising edge.

#### 5.1.2 Serial data In (SI)

The SI input pin is used to transfer data serially into the device. The data applied to the SI is sampled at the falling edge of the SCK signal.

#### 5.1.3 Serial clock (SCK)

The Data Input (SI) is latched at the falling edge of Serial Clock SCK. Data on Serial Data Out (SO) is shifted out at the rising edge of the serial clock (SCK). The serial clock SCK must be active only during a frame (SS low).

#### 5.1.4 Serial out (SO)

The content of the selected status or control register is transferred out of the device using the SO pin on the rising edge of SCK. Each subsequent rising edge of the SCK will shift the next bit out.

#### 5.1.5 SPI communication flow

The SPI communication is started by sending an SPI instruction to the device beginning with the MSB. The first two bits of this instruction are used as a device identifier (see [Table 24: SPI instruction byte](#)). Whether the transfer is a read or a write access is determined by the SPI command (see [Table 26: Command overview](#)). The SPI data is transmitted from the device at the same time as the data is received, although on different SCK edges. While the 8-bit instruction is sent, the device responds with the check byte. Since the first two bits of the instruction are used as a device identifier, the first two bits of the check byte are tristate. This avoids bus conflicts on the SO line. During a write access, the 8-bit data byte is received after the instruction byte. The device responds with **00<sub>H</sub>**. In a read cycle the device sends the 8-bit data, while the receive data bits are ignored (see [Figure 19: Write access](#) and [Figure 20: Read access](#)). If an invalid instruction is detected, the register of the device are not modified and the data byte **FF<sub>H</sub>** is transmitted instead of the data or **00<sub>H</sub>** respectively. The bit **TRANS\_F** in the check byte is set in case of an invalid instruction and transmitted during the next SPI-access. An instruction is invalid, if an unused instruction code is detected, the previous transmission has not been completed or the number of clocks is not equal to 16.

Figure 19. Write access

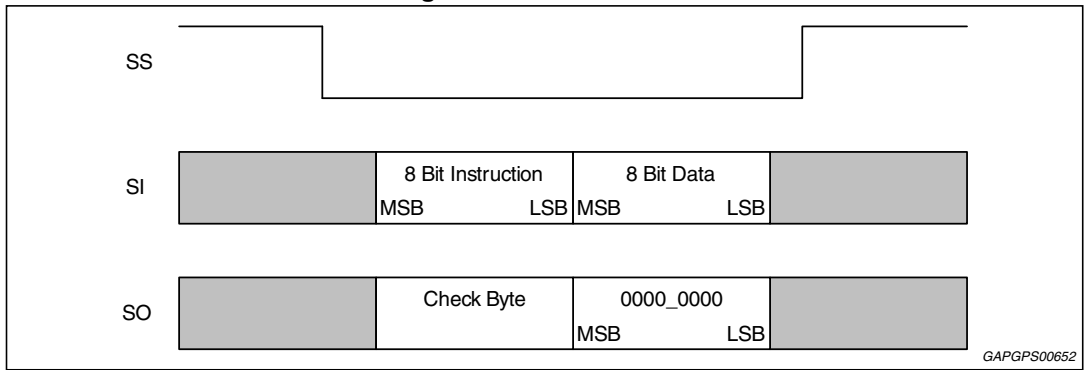
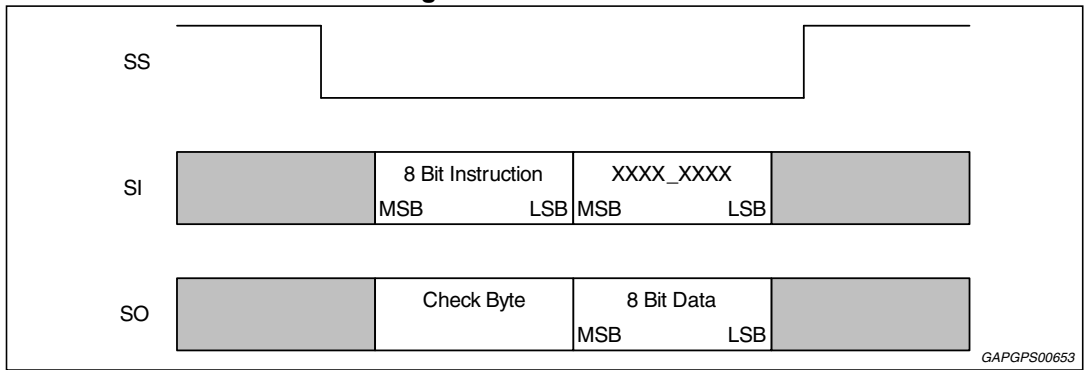

Figure 20. Read access



## 5.2 SPI-instruction

Table 24. SPI instruction byte

Bit	7	6	5	4	3	2	1	0
Name	CPAD1	CPAD0	INST<5>	INST<4>	INST<3>	INST<2>	INST<1>	INST<0>
Bit	Name	Content						
7	CPAD1	Chip Address: 0						
6	CPAD0	Chip Address: 0						
5	INST<5>	Read/Write: Read: 0 Write: 1						
4:0	INST<4:0>	SPI Instruction						

**Table 25. Check byte**

Bit	7	6	5	4	3	2	1	0
Name	Tristate	Tristate	1	0	1	0	1	TRANS_F
Bit	Name	Content						
7:6	Tristate	Tristate						
6:1		Fix Content: 10101						
0	TRANS_F	Transfer-Failure Invalid instruction TRANS_F = 1						

### 5.3 Device register map

**Table 26. Command overview**

Command	INST<5:0>	Content
RD_ID	00_0100	Read Device ID
RD_REV	00_0110	Read Device Revision
RD_DIA1	01_0000	Read Diagnostic Information Register 1
RD_DIA2	01_1000	Read Diagnostic Information Register 2
RD_CONFIG	00_1000	Read Configuration
RD_STATCON	00_1100	Read VDD Monitoring Status
RD_SPECIAL	00_1110	Read information from SPECIAL
WR_DIA1	11_0000	Write to Diagnostic Information Register 1
WR_DIA2	11_1000	Write to Diagnostic Information Register 2
WR_CONFIG	10_1000	Write Configuration
WR_STATCON	10_1100	Write VDD Monitoring Status
WR_SPECIAL	10_1110	Write information to SPECIAL
All Other	-	Invalid Command: TRANS_F: 1

## 5.4 SPI - control and status registers

Table 27. Device identifier (ID)

Bit	7	6	5	4	3	2	1	0
Name	ID<7>	ID<6>	ID<5>	ID<4>	ID<3>	ID<2>	ID<1>	ID<0>
Bit	Name	Content						
7:0	ID<7:0>	Device ID: <b>DFH</b>						

Table 28. Revision register (REV)

Bit	7	6	5	4	3	2	1	0
Name	SWR<3>	SWR<2>	SWR<1>	SWR<0>	MSR<3>	MSR<2>	MSR<1>	MSR<0>
Bit	Name	Content						
7:4	SWR<3:0>	Software Revision: <b>0H</b>						
3:0	MSR<3:0>	Mask Set Revision: <b>06H</b> <sup>(1)</sup>						

1. Here below the Mask set revision:

00H - AA  
 01H - BA  
 02H - CA  
 03H - CB  
 04H - DA  
 05H - DB  
 06H - DC

Table 29. DIA\_REG1

Bit	7	6	5	4	3	2	1	0
Name	/ABE / DIS	OT	Res	Res	DIA21	DIA20	DIA11	DIA10
Bit	Name	Content						
7	/ABE / DIS	H-bridge Disable: 0, if /ABE = 0 or DIS = 1						
6	OT	Over temperature: 0:OT, 1: no OT						
5:4	Reserved	0						
3	DIA21	Diagnose Bits ( <i>Table 30: Diagnosis bits (DIA_REG1)</i> )						
2	DIA20							
1	DIA11							
0	DIA10							
Reset <sup>(5.4.1)</sup>	7	6	5	4	3	2	1	0
POR	X	1	1	1	1	1	1	1
SPIR	X	1	X	X	1	1	1	1
ENDISR	X	1	X	X	1	1	1	1
RDR	X	X	X	X	X	X	X	X
DIACLR1	X	1	X	X	1	1	1	1

**Table 30. Diagnosis bits (DIA\_REG1)**

DIA21	DIA20	DIA11	DIA10	Description	Remark
0	0	0	1	Short Circuit to Ground at OUT1 (SCG1)	Latched
0	0	1	0	Short Circuit to Ground at OUT2 (SCG2)	Latched
0	1	0	1	Short Circuit to Battery at OUT1 (SCB1)	Latched
0	1	1	0	Short Circuit to Battery at OUT2 (SCB2)	Latched
0	1	1	1	Short Circuit over Load (SCL)	Latched
1	0	0	0	Short Circuit to Battery at Disabled Output	Latched
1	0	0	1	Short Circuit to Ground at Disabled Output	Latched
1	0	1	0	Open Load at disabled or active Output (OL)	Latched
1	1	0	1	Under Voltage at VS	Not Latched
1	1	1	1	No Failure	-

*Note: Reading this register does not reset the bits. Writing STACON\_REG.DIACLR1 = 0 transfers all latched errors to DIA\_REG2 and resets DIA\_REG1 afterwards, if there is no VS-undervoltage.*

**Table 31. Diagnosis register 2 (DIA\_REG2)**

Bit	7	6	5	4	3	2	1	0
Name	CurrRed	CurrLim	OT	Res	DIA21	DIA20	DIA11	DIA10
Bit	Name	Content						
7	CurrRed	Current Reduction: 0, if temperature dependent current reduction is active This information bit is reset after each read access						
6	CurrLim	Current Limitation: 0, if current limitation is active This information bit is reset after each read access						
5	OT	Over temperature 1 no over-temperature 0 over-temperature						
4	Res	Reserved, 0						
3	DIA21	Diagnosis Bits (see <a href="#">Table 32: Diagnosis bits (DIA_REG2)</a> )						
2	DIA20							
1	DIA11							
0	DIA10							
Reset <sup>(5.4.1)</sup>	7	6	5	4	3	2	1	0
POR	1	1	1	0	1	1	1	1
SPIR	1	1	1	X	1	1	1	1
ENDISR	1	1	X	X	X	X	X	X
RDR	1	1	X	X	X	X	X	X
DIACLR2	1	1	1	X	1	1	1	1



Table 32. Diagnosis bits (DIA\_REG2)

DIA21	DIA20	DIA11	DIA10	Description	Remark
0	0	0	1	Short Circuit to Ground at OUT1 (SCG1)	Latched
0	0	1	0	Short Circuit to Ground at OUT2 (SCG2)	Latched
0	1	0	1	Short Circuit to Battery at OUT1 (SCB1)	Latched
0	1	1	0	Short Circuit to Battery at OUT2 (SCB2)	Latched
0	1	1	1	Short Circuit over Load (SCL)	Latched
1	0	0	0	Short Circuit to Battery at Disabled Output	Latched
1	0	0	1	Short Circuit to Ground at Disabled Output	Latched
1	0	1	0	Open Load at disabled or active Output (OL)	Latched
1	1	1	1	No Failure	-

Table 33. Configuration register (CONFIG\_REG)

Bit	7	6	5	4	3	2	1	0
Name	FW	MUX	SPWM	SDIR	CL1	CL2	RESET	OLDA
Bit	Name	Content						
7	FW	Free-Wheeling mode selection 0: FW via Body Diode; 1: FW with active short of Body Diode						
6	MUX	Multiplex Bit for H-bridge control strategy: 0: control by bits SPWM and SDIR; 1: Control by inputs PWM and DIR						
5	SDIR	SPI control for Direction: Same as input DIR						
4	SPWM	SPI control for PWM: Same as input PWM						
3	CL1	See <a href="#">Table 34: Current Level (CONFIG_REG)</a> .						
2	CL2							
1	RESET	Reset: 0: Reset of device configuration to default; 1: No change						
0	OLDA	Open-Load Diagnosis in active mode: 1: OLD A is enabled; 0: OLD A is disabled						
Reset <sup>(5.4.1)</sup>	7	6	5	4	3	2	1	0
POR	1	1	1	1	1	0	1	0
SPIR	1	1	1	1	1	0	1	0
ENDISR	X	X	X	X	X	X	1	X
RDR	X	X	X	X	X	X	1	X

**Table 34. Current Level (CONFIG\_REG)**

CL1	CL2	Current Level	Typical Current
0	0	No Change	No Change
0	1	2	5.0 A
1	0	3 (default value)	6.6 A
1	1	4	8.6 A

**Table 35. Status and configuration register (STATCON\_REG)**

Bit	7	6	5	4	3	2	1	0
Name	CONFIG2	CONFIG1	CONFIG0	DIACLR2	DIACLR1	STATUS2	STATUS1	STATUS0
Bit	Name	Content						
7	CONFIG2	VDD Test Threshold: 0: VDD Threshold Test is on 1: VDD Threshold test is off						
6	CONFIG1	VDD Test Threshold: 1: Lower VDD Test Threshold is lifted 0:Upper VDD Test Threshold is lowered						
5	CONFIG0	VDD Over-Voltage Latch: 0: Latch is disabled 1: Latch is enabled						
4	DIACLR2	Reset DIA_REG2: 0: Reset errors in DIA_REG2 1: No action (Reading this bit always returns „1.)						
3	DIACLR1	Transfer Errors: 0: All latched errors of DIA_REG1 are transferred to DIA_REG2. DIA21,DIA20, DIA11, DIA10are set to “1111”. During VS-Undervoltage DIACLR1 is disabled 1: No action (Reading this bit always returns „1.)						
2	STATUS2	Logic Level at Pin /ABE						
1	STATUS1	VDD Under-Voltage: 0: Under-Voltage 1: No Under-Voltage						
0	STATUS0	VDD Over-Voltage: 0: Over-Voltage 1: No Over-Voltage This information is not reset during VS-Undervoltage. It will be reset by CONFIG0, SPI reset or internal VDD reset						
Reset <sup>(5.4.1)</sup>	7	6	5	4	3	2	1	0
POR	1	1	0	1	1	X	X	X
SPIR	1	1	0	1	1	X	X	X
ENDISR	X	X	X	1	1	X	X	X
RDR	X	X	X	1	1	X	X	X

*Note: Only the bits ‘CONFIG’ and ‘DIACLR’ in this register can be written, all other bits are ‘read-only’*

Table 36. Special register (SPECIAL\_REG)

Bit	7	6	5	4	3	2	1	0
Name	Not specified			OLDAFILTER	Not specified	SR	Not specified	SPRCSPEC
Controller access: write-access: WR_SPECIAL read-access: RD_SPECIAL								
Bit	Name	Content						
7	Not specified	-						
6	Not specified	-						
5	Not specified	-						
4	OLDAFILTER	Open-load filter in active mode only. OLDAFILTER is a don't care in case of Off state 1: open-load in on detected after one retry 0: openload in on detected after 40 ms						
3	Not specified	-						
2	SR	Voltage SR selection 1: fast slew rate 0: slow slew rate						
1	Not specified	-						
0	SPRCSPEC	SPREADSPECTRUM mode selection 1: spread spectrum = active 0: spread spectrum = disabled Spread spectrum = active provides the internal state machine with slightly jittering clock. Spread spectrum = disabled. The internal state machine runs with constant clock frequency.						
Reset (5.4.1)	7	6	5	4	3	2	1	0
POR	0	0	0	1	0	0	0	1
SPIR	0	0	0	1	0	0	0	1
ENDISR	X	X	X	X	X	X	X	X
RDR	X	X	X	X	X	X	X	X

### 5.4.1 Reset sources

- POR: Reset due to a VDD power up on VDD (Power-Up Reset)
- ENDISR: Reset caused by an enable or disable of the power stages (DIS or /ABE edge triggered) (Enable-/Disable Reset)

### 5.4.2 Configuration registers reset sources

- POR: Reset due to a VDD power up on VDD (Power-Up Reset)
- SPIR: Reset by setting bit **RESET** in the configuration register (CONFIG\_REG) (SPIReset)
- RDIR: Reset caused by a read access to the corresponding register (Read Register)
- DIACLR1: Reset by setting bit DIACLR1 in the Status and Configuration Register STATCON (Diagnosis Reset 1)
- DIACLR2: Reset by setting bit DIACLR2 in the Status and Configuration Register STATCON (Diagnosis Reset 2)

# 6 Application circuit

Figure 21. Application circuit

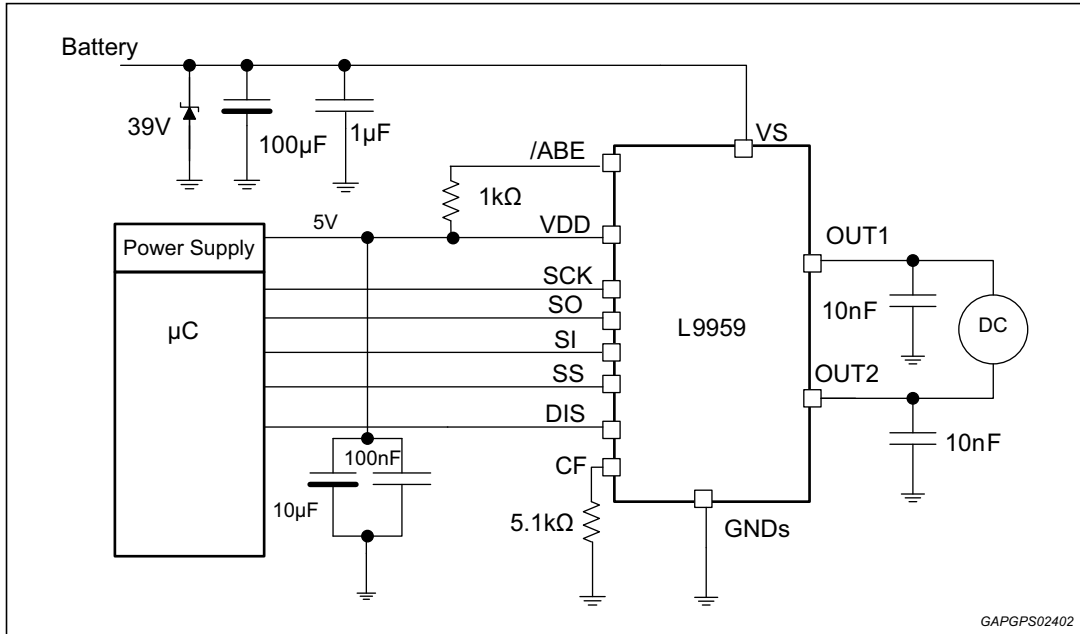

GAPGPS02402

# 7 Package information

In order to meet environmental requirements, ST offers these devices in different grades of ECOPACK® packages, depending on their level of environmental compliance. ECOPACK® specifications, grade definitions and product status are available at: [www.st.com](http://www.st.com).  
 ECOPACK® is an ST trademark.

## 7.1 PowerSSO-24 (exposed pad) package information

Figure 22. PowerSSO-24 (exposed pad) package outline

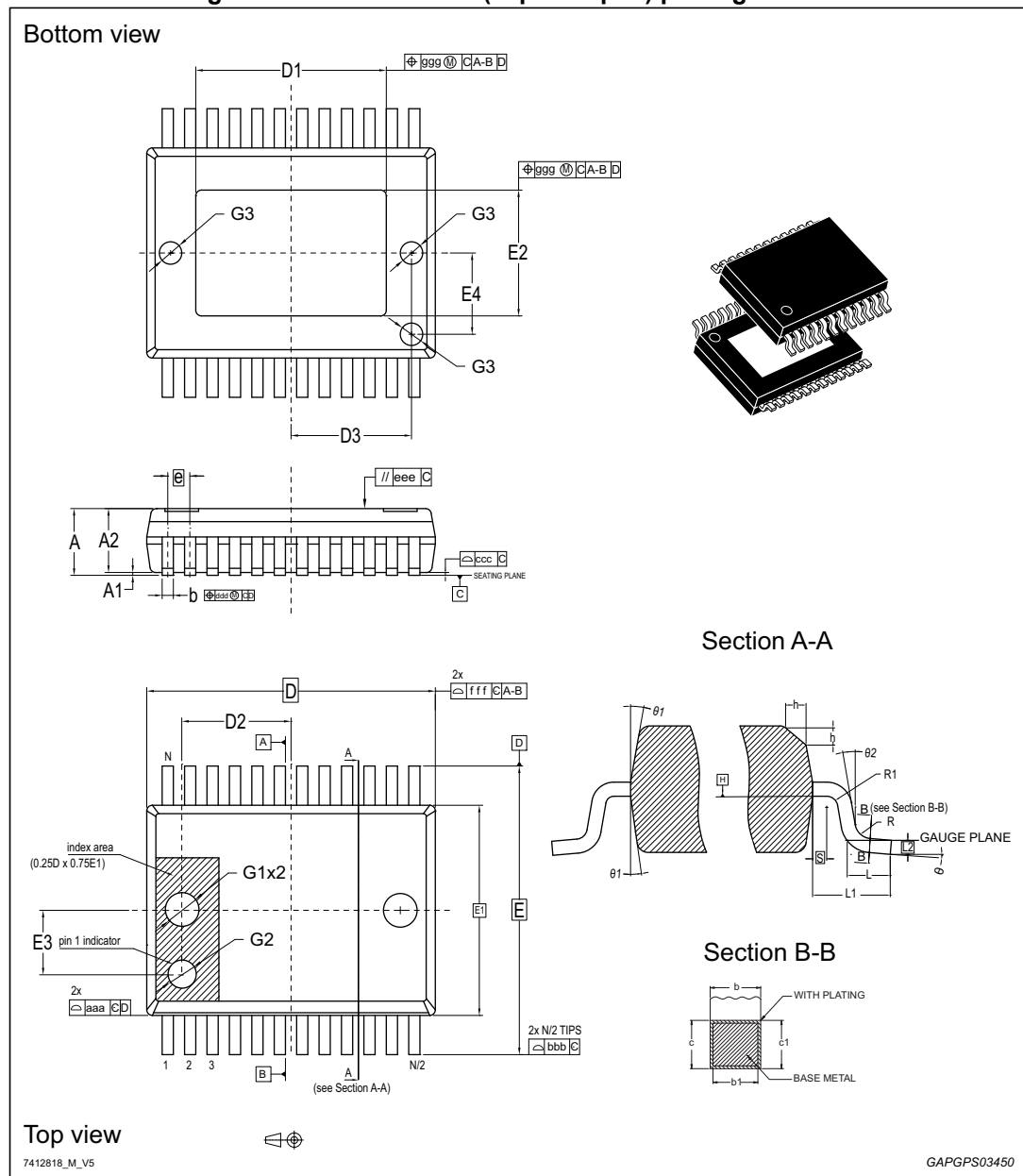

Table 37. PowerSSO-24 (exposed pad) package mechanical data

Ref	Dimensions					
	Millimeters			Inches <sup>(1)</sup>		
	Min.	Typ.	Max.	Min.	Typ.	Max.
Θ	0°	-	8°	0°	-	8°
Θ1	5°	-	10°	5°	-	10°
Θ2	0°	-	-	0°	-	-
A	-	-	2.45	-	-	0.0965
A1	0.0	-	0.1	0.0	-	0.0039
A2	2.15	-	2.35	0.0846	-	0.0925
b	0.33	-	0.51	0.013	-	0.0201
b1	0.28	0.40	0.48	0.011	0.0157	0.0189
c	0.23	-	0.32	0.0091	-	0.0126
c1	0.20	0.20	0.30	0.0079	0.0079	0.0118
D <sup>(2)</sup>	10.30 BSC			0.4055 BSC		
D1	VARIATION					
D2	-	3.65	-	-	0.1437	-
D3	-	4.30	-	-	0.1693	-
e	0.80 BSC			0.0315 BSC		
E	10.30 BSC			0.4055 BSC		
E1 <sup>(2)</sup>	7.50 BSC			0.2953 BSC		
E2	VARIATION					
E3	-	2.30	-	-	0.0906	-
E4	-	2.90	-	-	0.1142	-
G1	-	1.20	-	-	0.0472	-
G2	-	1.0	-	-	0.0394	-
G3	-	0.80	-	-	0.0315	-
h	0.30	-	0.40	0.0118	-	0.0157
L	0.55	0.70	0.85	0.0217	-	0.0335
L1	1.40 REF			0.0551 REF		
L2	0.25 BSC			0.0098 BSC		
N	24 (# lead)					
R	0.30	-	-	0.0118	-	-
R1	0.20	-	-	0.0079	-	-
S	0.25	-	-	0.0098	-	-

**Table 37. PowerSSO-24 (exposed pad) package mechanical data (continued)**

Ref	Dimensions					
	Millimeters			Inches <sup>(1)</sup>		
	Min.	Typ.	Max.	Min.	Typ.	Max.
<b>Tolerance of form and position</b>						
aaa	0.20			0.0079		
bbb	0.20			0.0079		
ccc	0.10			0.0039		
ddd	0.20			0.0079		
eee	0.10			0.0039		
fff	0.20			0.0079		
ggg	0.15			0.0059		
<b>VARIATIONS</b>						
<b>Option A</b>						
D1	6.5	-	7.1	0.2559	-	0.2795
E2	4.1	-	4.7	0.1614	-	0.1850
<b>Option B</b>						
D1	4.9	-	5.5	0.1929	-	0.2165
E2	4.1	-	4.7	0.1614	-	0.1850

1. Values in inches are converted from mm and rounded to 4 decimal digits.
2. Dimensions D and E1 do not include mold flash or protrusions. Allowable mold flash or protrusions is '0.25 mm' per side D and '0.15 mm' per side E1. D and E1 are Maximum plastic body size dimensions including mold mismatch.

## 7.2 PowerSSO-36 (exposed pad) package information

Figure 23. PowerSSO-36 (exposed pad) package outline

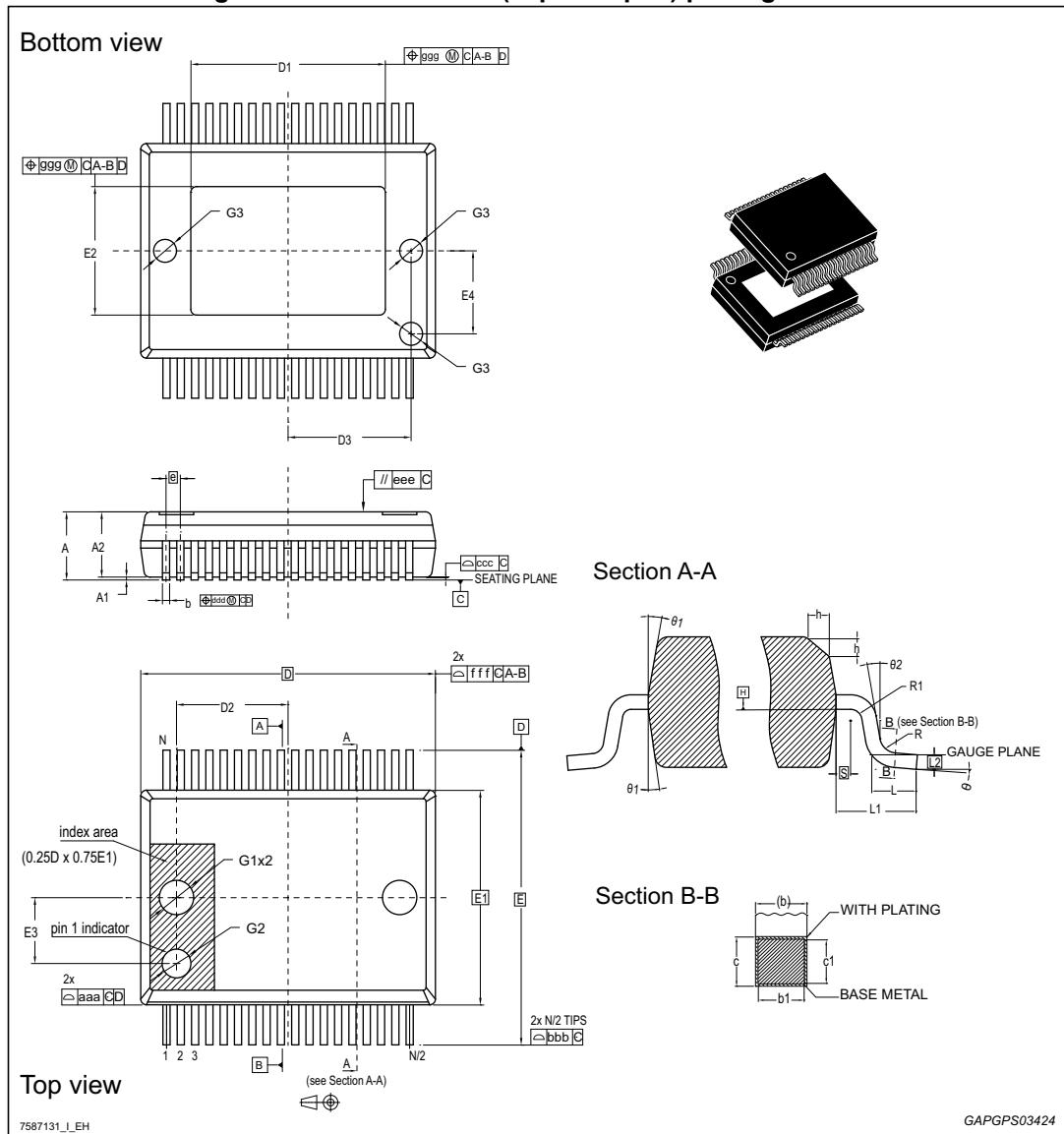

Table 38. PowerSSO-36 (exposed pad) package mechanical data

Ref	Dimensions					
	Millimeters			Inches <sup>(1)</sup>		
	Min.	Typ.	Max.	Min.	Typ.	Max.
Θ	0°	-	8°	0°	-	8°
Θ1	5°	-	10°	5°	-	10°
Θ2	0°	-	-	0°	-	-
A	2.15	-	2.45	0.0846	-	0.0965

**Table 38. PowerSSO-36 (exposed pad) package mechanical data (continued)**

Ref	Dimensions					
	Millimeters			Inches <sup>(1)</sup>		
	Min.	Typ.	Max.	Min.	Typ.	Max.
A1	0.0	-	0.1	0.0	-	0.0039
A2	2.15	-	2.35	0.0846	-	0.0925
b	0.18	-	0.32	0.0071	-	0.0126
b1	0.13	0.25	0.3	0.0051	0.0098	0.0118
c	0.23	-	0.32	0.0091	-	0.0126
c1	0.2	0.2	0.3	0.0079	0.0079	0.0118
D <sup>(2)</sup>	10.30 BSC			0.4055 BSC		
D1	<b>VARIATION</b>					
D2	-	3.65	-	-	0.1437	-
D3	-	4.3	-	-	0.1693	-
e	0.50 BSC			0.0197 BSC		
E	10.30 BSC			0.4055 BSC		
E1 <sup>(2)</sup>	7.50 BSC			0.2953 BSC		
E2	<b>VARIATION</b>					
E3	-	2.3	-	-	0.0906	-
E4	-	2.9	-	-	0.1142	-
G1	-	1.2	-	-	0.0472	-
G2	-	1	-	-	0.0394	-
G3	-	0.8	-	-	0.0315	-
h	0.3	-	0.4	0.0118	-	0.0157
L	0.55	0.7	0.85	0.0217	-	0.0335
L1	1.40 REF			0.0551 REF		
L2	0.25 BSC			0.0098 BSC		
N	36			1.4173		
R	0.3	-	-	0.0118	-	-
R1	0.2	-	-	0.0079	-	-
S	0.25	-	-	0.0098	-	-
<b>Tolerance of form and position</b>						
aaa	0.2			0.0079		
bbb	0.2			0.0079		
ccc	0.1			0.0039		
ddd	0.2			0.0079		

Table 38. PowerSSO-36 (exposed pad) package mechanical data (continued)

Ref	Dimensions					
	Millimeters			Inches <sup>(1)</sup>		
	Min.	Typ.	Max.	Min.	Typ.	Max.
eee	0.1			0.0039		
fff	0.2			0.0079		
ggg	0.15			0.0059		
<b>VARIATIONS</b>						
<b>Option A</b>						
D1	6.5	-	7.1	0.2559	-	0.2795
E2	4.1	-	4.7	0.1614	-	0.1850
<b>Option B</b>						
D1	4.9	-	5.5	0.1929	-	0.2165
E2	4.1	-	4.7	0.1614	-	0.1850
<b>Option C</b>						
D1	6.9	-	7.5	0.2717	-	0.2953
E2	4.3	-	5.2	0.1693	-	0.2047

1. Values in inches are converted from mm and rounded to 4 decimal digits.
2. Dimensions D and E1 do not include mold flash or protrusions. Allowable mold flash or protrusions is '0.25 mm' per side D and '0.15 mm' per side E1. D and E1 are Maximum plastic body size dimensions including mold mismatch.

## 8 Revision history

**Table 39. Document revision history**

Date	Revision	Changes
27-Jul-2015	1	Initial release.
28-Oct-2015	2	Added: – New commercial part number in <i>Table 1: Device summary on page 1</i> ; – <i>Figure 4: PSSO36 (Single version) pin connection (top view) on page 8</i> ; – <i>Table 4: L9959U (Single version in PSSO36) pin out on page 12</i> . Corrected in <i>Table 10: VDD monitoring on page 15</i> the test conditions of $V_{ABE\_OUTL}$ . Updated <i>Description on page 1</i> .
25-Feb-2016	3	Corrected typo in the <i>Table 10: VDD monitoring on page 15</i> (Test condition column of the ' $V_{ABE\_OUTL}$ ' parameter).

**IMPORTANT NOTICE – PLEASE READ CAREFULLY**

STMicroelectronics NV and its subsidiaries ("ST") reserve the right to make changes, corrections, enhancements, modifications, and improvements to ST products and/or to this document at any time without notice. Purchasers should obtain the latest relevant information on ST products before placing orders. ST products are sold pursuant to ST's terms and conditions of sale in place at the time of order acknowledgement.

Purchasers are solely responsible for the choice, selection, and use of ST products and ST assumes no liability for application assistance or the design of Purchasers' products.

No license, express or implied, to any intellectual property right is granted by ST herein.

Resale of ST products with provisions different from the information set forth herein shall void any warranty granted by ST for such product.



ST and the ST logo are trademarks of ST. All other product or service names are the property of their respective owners.

Information in this document supersedes and replaces information previously supplied in any prior versions of this document.







© 2016 STMicroelectronics – All rights reserved

## Looking for pricing, stock, or lifecycle information?

Click below to explore more details on WIN SOURCE:

-  [View L9959T-TR-D on WIN SOURCE](#)
-  [STMicroelectronics Information](#)

## Optimize Your Supply Chain with WIN SOURCE Solutions

-  Global Sourcing Solution
-  Obsolete Management
-  Cost Control Management
-  Shortage Management
-  Alternative Solution
-  Excess Inventory Management