



**THE DATASHEET OF
DDTC124XUA-7**



Features

- Epitaxial Planar Die Construction
- Built-In Biasing Resistors
- Surface Mount Package Suited for Automated Assembly
- **Totally Lead-Free & Fully RoHS Compliant (Notes 1 & 2)**
- **Halogen and Antimony Free. "Green" Device (Note 3)**
- **Qualified to AEC-Q101 Standards for High Reliability**

Mechanical Data

- Case: SOT323
- Case Material: Molded Plastic, "Green" Molding Compound; UL Flammability Classification Rating 94V-0
- Moisture Sensitivity: Level 1 per J-STD-020
- Terminals: Finish – Matte Tin Plated Leads, Solderable per MIL-STD-202, Method 208 (E3)
- Weight: 0.006 grams (Approximate)

Part Number	R1(NOM)	R2(NOM)
DDTC113ZUA	1kΩ	10kΩ
DDTC123YUA	2.2kΩ	10kΩ
DDTC123JUA	2.2kΩ	47kΩ
DDTC143XUA	4.7kΩ	10kΩ
DDTC143FUA	4.7kΩ	22kΩ
DDTC143ZUA	4.7kΩ	47kΩ
DDTC114YUA	10kΩ	47kΩ
DDTC114WUA	10kΩ	4.7kΩ
DDTC124XUA	22kΩ	47kΩ
DDTC144VUA	47kΩ	10kΩ
DDTC144WUA	47kΩ	22kΩ



Top View

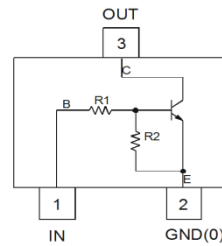

Device Schematic

Ordering Information (Note 4)

Product	Compliance	Marking	Reel Size (inches)	Tape Width (mm)	Quantity per Reel
DDTC113ZUA-7-F	AEC-Q101	N02	7	8	3,000
DDTC123YUA-7-F	AEC-Q101	N05	7	8	3,000
DDTC123JUA-7-F	AEC-Q101	N06	7	8	3,000
DDTC143XUA-7-F	AEC-Q101	N09	7	8	3,000
DDTC143FUA-7-F	AEC-Q101	N10	7	8	3,000
DDTC143ZUA-7-F	AEC-Q101	N11	7	8	3,000
DDTC114YUA-7-F	AEC-Q101	N14	7	8	3,000
DDTC114WUA-7-F	AEC-Q101	N15	7	8	3,000
DDTC124XUA-7-F	AEC-Q101	N18	7	8	3,000
DDTC144VUA-7-F	AEC-Q101	N21	7	8	3,000
DDTC144WUA-7-F	AEC-Q101	N22	7	8	3,000

- Notes:
1. No purposely added lead. Fully EU Directive 2002/95/EC (RoHS) & 2011/65/EU (RoHS 2) compliant.
 2. See http://www.diodes.com/quality/lead_free.html for more information about Diodes Incorporated's definitions of Halogen- and Antimony-free, "Green" and Lead-free.
 3. Halogen- and Antimony-free "Green" products are defined as those which contain <900ppm bromine, <900ppm chlorine (<1500ppm total Br + Cl) and <1000ppm antimony compounds.
 4. For packaging details, go to our website at <http://www.diodes.com/products/packages.html>.

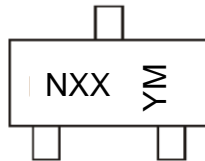
Marking Information
SOT323

NXX = Product Type Marking Code
 YM = Date Code Marking
 Y = Year (ex: D = 2016)
 M = Month (ex: 9 = September)

Date Code Key

Year	2016	2017	2018	2019	2020	2021	2022	2023	2024	2025	2026	
Code	D	E	F	G	H	I	J	K	L	M	N	
Month	Jan	Feb	Mar	Apr	May	Jun	Jul	Aug	Sep	Oct	Nov	Dec
Code	1	2	3	4	5	6	7	8	9	O	N	D

Absolute Maximum Ratings NPN Section (@T_A = +25°C, unless otherwise specified.)

Characteristic	Symbol	Value	Unit
Supply Voltage <Pin: (3) to (2)>	V _{CC}	50	V
Input Voltage <Pin: (1) to (2)>	V _{IN}	DDTC113ZUA -5 to +10 DDTC123YUA -5 to +12 DDTC123JUA -5 to +12 DDTC143XUA -7 to +20 DDTC143FUA -6 to +30 DDTC143ZUA -5 to +30 DDTC114YUA -6 to +40 DDTC114WUA -10 to +30 DDTC124XUA -10 to +40 DDTC144VUA -15 to +40 DDTC144WUA -10 to +40	V
Output Current	I _O	DDTC113ZUA 100 DDTC123YUA 100 DDTC123JUA 100 DDTC143XUA 100 DDTC143FUA 100 DDTC143ZUA 100 DDTC114YUA 70 DDTC114WUA 100 DDTC124XUA 50 DDTC144VUA 30 DDTC144WUA 30	mA
Output Current	I _C (Max)	100	mA

Thermal Characteristics (@T_A = +25°C, unless otherwise specified.)

Characteristic	Symbol	Value	Unit
Power Dissipation (Notes 5 & 6)	P _D	200	mW
Thermal Resistance, Junction to Ambient Air (Note 5)	R _{θJA}	625	°C/W
Operating and Storage Temperature Range	T _J , T _{STG}	-55 to +150	°C

Notes: 5. Mounted on FR4 PC Board with minimum recommended pad layout.
 6. 150mW per element must not be exceeded.

Electrical Characteristics (@T_A = +25°C, unless otherwise specified.)

Characteristic		Symbol	Min	Typ	Max	Unit	Test Condition	
Input Voltage	DDTC113ZUA	V _{I(OFF)}	0.3	—	—	V	V _{CC} = 5V, I _O = 100μA	
	DDTC123YUA		0.3					
	DDTC123JUA		0.5					
	DDTC143XUA		0.3					
	DDTC143FUA		0.3					
	DDTC143ZUA		0.5					
	DDTC114YUA		0.3					
	DDTC114WUA		0.8					
	DDTC124XUA		0.4					
	DDTC144VUA		1.0					
	DDTC144WUA		0.8					
	DDTC113ZUA		V _{I(ON)}					—
	DDTC123YUA	3.0		V _O = 0.3V, I _O = 20mA				
	DDTC123JUA	1.1		V _O = 0.3V, I _O = 5mA				
	DDTC143XUA	2.5		V _O = 0.3V, I _O = 20mA				
	DDTC143FUA	1.3		V _O = 0.3V, I _O = 3mA				
	DDTC143ZUA	1.3		V _O = 0.3V, I _O = 5mA				
	DDTC114YUA	1.4		V _O = 0.3V, I _O = 1mA				
	DDTC114WUA	3.0		V _O = 0.3V, I _O = 2mA				
	DDTC124XUA	2.5		V _O = 0.3V, I _O = 2mA				
	DDTC144VUA	5.0		V _O = 0.3V, I _O = 2mA				
	DDTC144WUA	4.0		V _O = 0.3V, I _O = 2mA				
Output Voltage	V _{O(ON)}	—		0.1	0.3	V	I _O /I _I = 5mA / 0.25mA DDTC123JUA I _O /I _I = 5mA / 0.25mA DDTC143ZUA I _O /I _I = 5mA / 0.25mA DDTC114YUA I _O /I _I = 10mA / 0.5mA All Others	
Input Current	DDTC113ZUA	I _I	—	—	7.2	mA	V _I = 5V	
	DDTC123YUA				3.8			
	DDTC123JUA				3.6			
	DDTC143XUA				1.8			
	DDTC143FUA				1.8			
	DDTC143ZUA				1.8			
	DDTC114YUA				0.88			
	DDTC114WUA				0.88			
	DDTC124XUA				0.36			
	DDTC144VUA				0.16			
	DDTC144WUA				0.16			
	Output Current				I _{O(OFF)}			—
DC Current Gain	DDTC113ZUA	G _I	—	—	—	—	V _O = 5V, I _O = 5mA	
	DDTC123YUA						33	V _O = 5V, I _O = 10mA
	DDTC123JUA						80	V _O = 5V, I _O = 10mA
	DDTC143XUA						30	V _O = 5V, I _O = 10mA
	DDTC143FUA						68	V _O = 5V, I _O = 10mA
	DDTC143ZUA						80	V _O = 5V, I _O = 10mA
	DDTC114YUA						68	V _O = 5V, I _O = 5mA
	DDTC114WUA						24	V _O = 5V, I _O = 10mA
	DDTC124XUA						68	V _O = 5V, I _O = 5mA
	DDTC144VUA						33	V _O = 5V, I _O = 5mA
	DDTC144WUA						56	V _O = 5V, I _O = 5mA
	Input Resistor (R ₁) Tolerance						ΔR ₁	-30
Resistance Ratio Tolerance	ΔR ₂ /R ₁	-20	—	+20	%	—		
Gain-Bandwidth Product	f _T	—	250	—	MHz	V _{CE} = 10V, I _E = 5mA, f = 100MHz		

Typical Curves – Total Device

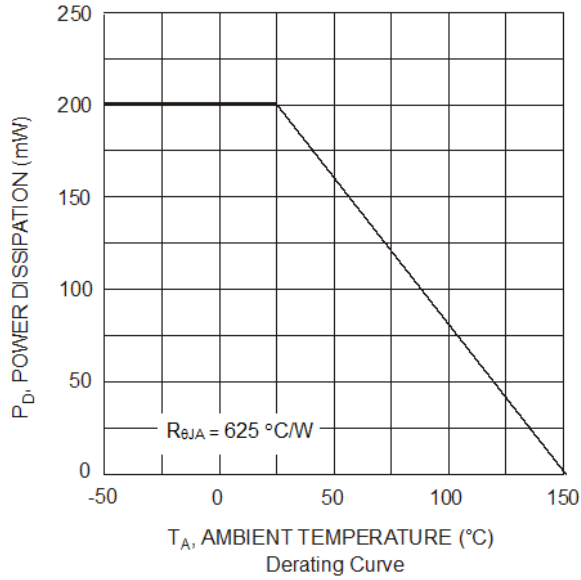

Typical Curves – DDTC123JUA (@T_A = +25°C, unless otherwise specified.)

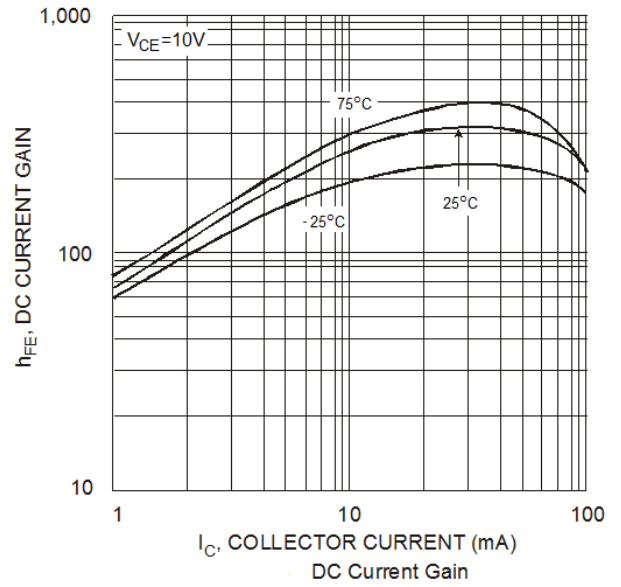
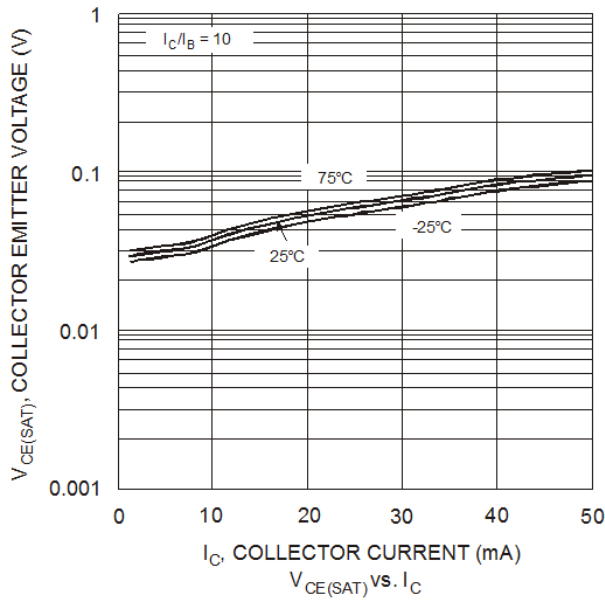

Typical Curves – DDTC123JUA (continued)

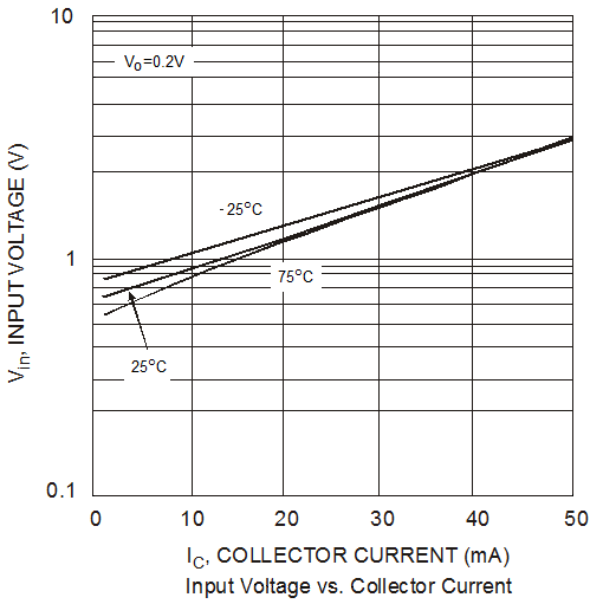
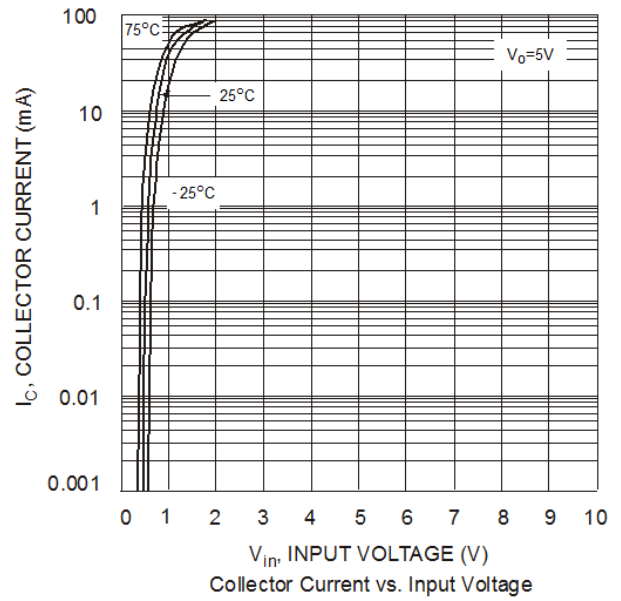
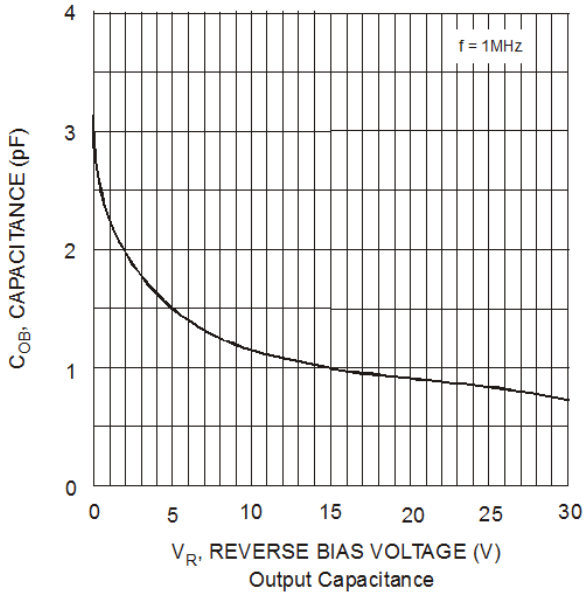

Package Outline Dimensions

Please see <http://www.diodes.com/package-outlines.html> for the latest version.

SOT323

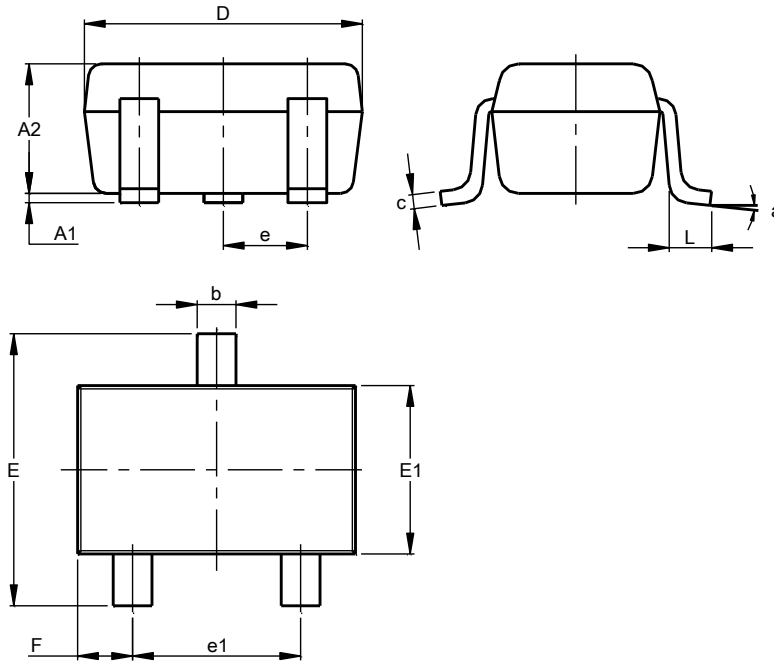

SOT323			
Dim	Min	Max	Typ
A1	0.00	0.10	0.05
A2	0.90	1.00	0.95
b	0.25	0.40	0.30
c	0.10	0.18	0.11
D	1.80	2.20	2.15
E	2.00	2.20	2.10
E1	1.15	1.35	1.30
e	0.650 BSC		
e1	1.20	1.40	1.30
F	0.375	0.475	0.425
L	0.25	0.40	0.30
a	0°	8°	--
All Dimensions in mm			

Suggested Pad Layout

Please see <http://www.diodes.com/package-outlines.html> for the latest version.

SOT323

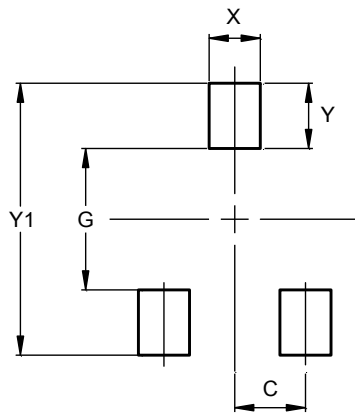

Dimensions	Value (in mm)
C	0.650
G	1.300
X	0.470
Y	0.600
Y1	2.500

IMPORTANT NOTICE

DIODES INCORPORATED MAKES NO WARRANTY OF ANY KIND, EXPRESS OR IMPLIED, WITH REGARDS TO THIS DOCUMENT, INCLUDING, BUT NOT LIMITED TO, THE IMPLIED WARRANTIES OF MERCHANTABILITY AND FITNESS FOR A PARTICULAR PURPOSE (AND THEIR EQUIVALENTS UNDER THE LAWS OF ANY JURISDICTION).

Diodes Incorporated and its subsidiaries reserve the right to make modifications, enhancements, improvements, corrections or other changes without further notice to this document and any product described herein. Diodes Incorporated does not assume any liability arising out of the application or use of this document or any product described herein; neither does Diodes Incorporated convey any license under its patent or trademark rights, nor the rights of others. Any Customer or user of this document or products described herein in such applications shall assume all risks of such use and will agree to hold Diodes Incorporated and all the companies whose products are represented on Diodes Incorporated website, harmless against all damages.

Diodes Incorporated does not warrant or accept any liability whatsoever in respect of any products purchased through unauthorized sales channel. Should Customers purchase or use Diodes Incorporated products for any unintended or unauthorized application, Customers shall indemnify and hold Diodes Incorporated and its representatives harmless against all claims, damages, expenses, and attorney fees arising out of, directly or indirectly, any claim of personal injury or death associated with such unintended or unauthorized application.

Products described herein may be covered by one or more United States, international or foreign patents pending. Product names and markings noted herein may also be covered by one or more United States, international or foreign trademarks.

This document is written in English but may be translated into multiple languages for reference. Only the English version of this document is the final and determinative format released by Diodes Incorporated.

LIFE SUPPORT

Diodes Incorporated products are specifically not authorized for use as critical components in life support devices or systems without the express written approval of the Chief Executive Officer of Diodes Incorporated. As used herein:

A. Life support devices or systems are devices or systems which:

1. are intended to implant into the body, or
2. support or sustain life and whose failure to perform when properly used in accordance with instructions for use provided in the labeling can be reasonably expected to result in significant injury to the user.

B. A critical component is any component in a life support device or system whose failure to perform can be reasonably expected to cause the failure of the life support device or to affect its safety or effectiveness.

Customers represent that they have all necessary expertise in the safety and regulatory ramifications of their life support devices or systems, and acknowledge and agree that they are solely responsible for all legal, regulatory and safety-related requirements concerning their products and any use of Diodes Incorporated products in such safety-critical, life support devices or systems, notwithstanding any devices- or systems-related information or support that may be provided by Diodes Incorporated. Further, Customers must fully indemnify Diodes Incorporated and its representatives against any damages arising out of the use of Diodes Incorporated products in such safety-critical, life support devices or systems.

Copyright © 2016, Diodes Incorporated

www.diodes.com

Looking for pricing, stock, or lifecycle information?

Click below to explore more details on WIN SOURCE:

 [View DDTTC124XUA-7 on WIN SOURCE](#)

 [Diodes Incorporated](#) Information

Optimize Your Supply Chain with WIN SOURCE Solutions

-  Global Sourcing Solution
-  Obsolete Management
-  Cost Control Management
-  Shortage Management
-  Alternative Solution
-  Excess Inventory Management