



**THE DATASHEET OF  
PQ033EF02SZH**



# PQxxxEF02SZH Series

TO-220 Type, Low Voltage Operation  
Low Power-Loss Voltage Regulators

## ■ Features

1. Low voltage operation  
(Minimum operating voltage: 2.35V)
2. Low dissipation current  
(Dissipation current at no load: MAX. 2mA  
Output OFF-state dissipation current: MAX. 5μA)
3. Low power-loss  
Dropout voltage: MAX. 0.5V
4. Built-in overcurrent and overheat protection functions
5. RoHS directive compliant

## ■ Applications

1. AV equipment  
(Digital TV/STB/PDP/DVD recorder)
2. OA equipment  
(Printer/LCD monitor/Copier/LC projector)

## ■ Model Line-up

Output voltage	Model No.	Output voltage	Model No.
1.5V	<b>PQ015EF02SZH</b>	2.5V	<b>PQ025EF02SZH</b>
1.8V	<b>PQ018EF02SZH</b>	3.3V	<b>PQ033EF02SZH</b>

## ■ Absolute Maximum Ratings

(Ta=25°C)

Parameter	Symbol	Rating	Unit
*1 Input voltage	V <sub>IN</sub>	10	V
*1 ON/OFF control terminal voltage	V <sub>C</sub>	10	V
Output current	I <sub>O</sub>	2.0	A
*2 Power dissipation	P <sub>D1</sub>	1.4	W
	P <sub>D2</sub>	15	
*3 Junction temperature	T <sub>J</sub>	150	°C
Operating temperature	T <sub>opr</sub>	-40 to +85	°C
Storage temperature	T <sub>stg</sub>	-40 to +150	°C
Soldering temperature	T <sub>sol</sub>	260(10s)	°C

\*1 All are open except GND and applicable terminals.  
 \*2 P<sub>D1</sub>: No heat sink, P<sub>D2</sub>: With infinite heat sink.  
 \*3 Overheat protection may operate at T<sub>J</sub>=125°C to 150°C

## ■ Outline Dimensions

(Unit : mm)

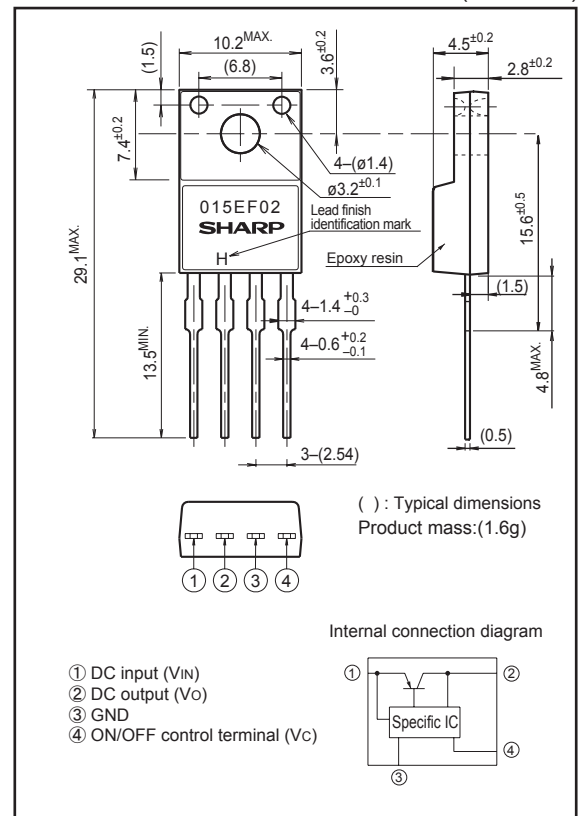

Lead finish: Lead-free solder plating  
(Composition: Sn2Cu)

Notice The content of data sheet is subject to change without prior notice.

In the absence of confirmation by device specification sheets, SHARP takes no responsibility for any defects that may occur in equipment using any SHARP devices shown in catalogs, data books, etc. Contact SHARP in order to obtain the latest device specification sheets before using any SHARP device.

### Electrical Characteristics

(Unless otherwise specified, condition shall be  $V_{IN}=V_O(TYP.)+1V, I_O=1A, V_C=2.7V, T_a=25^\circ C$ )

Parameter	Symbol	Conditions	MIN.	TYP.	MAX.	Unit
Input voltage	$V_{IN}$	-	Refer to the table below			V
Output voltage	$V_O$	-	Refer to the table below			V
Load regulation	$Reg_L$	$I_O=5mA$ to $2.0A$	-	0.2	2.0	%
Line regulation	$Reg_l$	$V_{IN}=V_O(TYP.)+1V$ to $V_O(TYP.)+6V, I_O=5mA$	-	0.1	1.0	%
Temperature coefficient of output voltage	$TcV_O$	$T_j=0$ to $+125^\circ C, I_O=5mA$	-	$\pm 0.01$	-	%/ $^\circ C$
Ripple rejection	RR	-	45	60	-	dB
*4 Dropout voltage	$V_{I-O}$	$I_O=2A$ *5	-	-	0.5	V
*6 ON-state voltage for control	$V_{C(ON)}$	-	2.0	-	-	V
ON-state current for control	$I_{C(ON)}$	-	-	-	200	$\mu A$
OFF-state voltage for control	$V_{C(OFF)}$	-	-	-	0.8	V
OFF-state current for control	$I_{C(OFF)}$	$V_C=0.4V$	-	-	2	$\mu A$
Quiescent current	$I_q$	$I_O=0A$	-	1	2	mA
Output OFF-state dissipation current	$I_{qs}$	$I_O=0A, V_C=0.4V$	-	-	5	$\mu A$

\* 4 Applied to PQ033EF02SZH.

\* 5 Input voltage shall be the value when output voltage is 95% in comparison with the initial value.

\* 6 In case of opening control terminal ④, output voltage turns off.

Table.1 Input Voltage Range

Model No.	Symbol	Conditions	MIN.	TYP.	MAX.	Unit
PQ015EF02SZH	$V_{IN}$	$I_O=1A, V_C=2.7V, T_a=25^\circ C$	2.35	-	10	V
PQ018EF02SZH			2.35	-	10	
PQ025EF02SZH			3.0	-	10	
PQ033EF02SZH			3.8	-	10	

Table.2 Output Voltage

Model No.	Symbol	Conditions	MIN.	TYP.	MAX.	Unit
PQ015EF02SZH	$V_O$	$V_{IN}=V_O(TYP.)+1V, I_O=1A, V_C=2.7V, T_a=25^\circ C$	1.45	1.5	1.55	V
PQ018EF02SZH			1.75	1.8	1.85	
PQ025EF02SZH			2.438	2.5	2.562	
PQ033EF02SZH			3.218	3.3	3.382	

Fig.1 Test Circuit

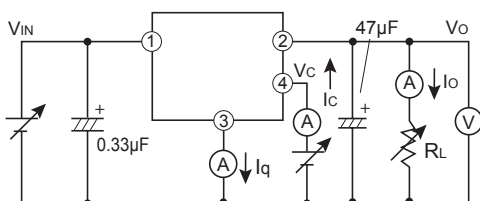
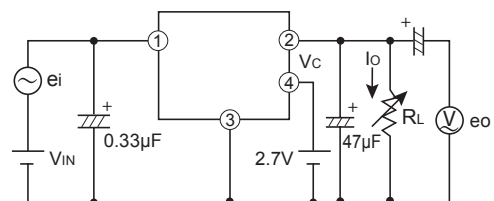
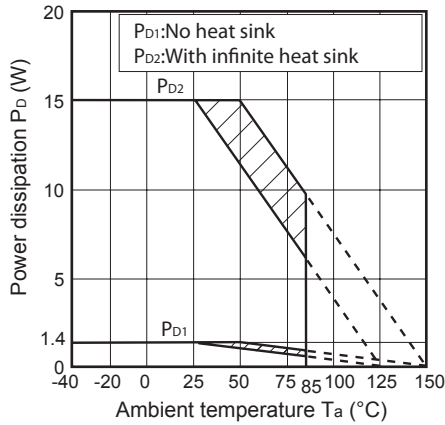

Fig.2 Test Circuit of Ripple Rejection



$f=120Hz$  (sine wave)  
 $e_i(rms)=0.5V$   
 $V_{IN}=V_O(TYP.)+2V$   
 $I_O=0.3A$   
 $RR=20 \log(e_i(rms)/e_o(rms))$

Fig.3 Power Dissipation vs. Ambient Temperature



Note) Oblique line portion: Overheat protection may operate in this area.

Fig.4 Overcurrent Protection Characteristics (PQ015EF02SZH)

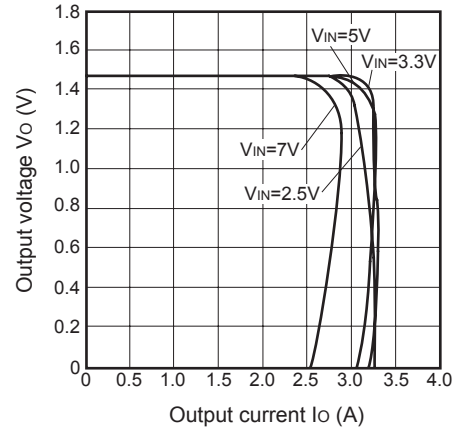

Fig.5 Overcurrent Protection Characteristics (PQ018EF02SZH)

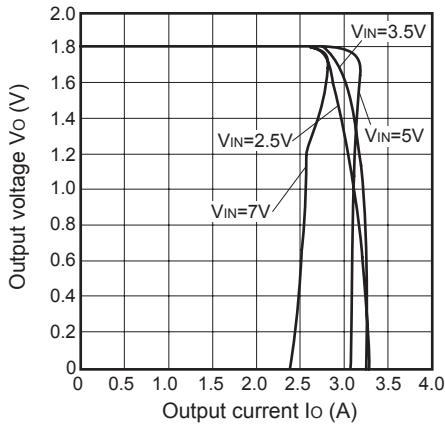

Fig.6 Overcurrent Protection Characteristics (PQ025EF02SZH)

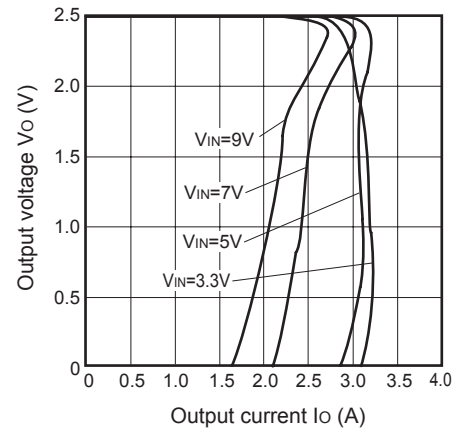

Fig.7 Overcurrent Protection Characteristics (PQ033EF02SZH)

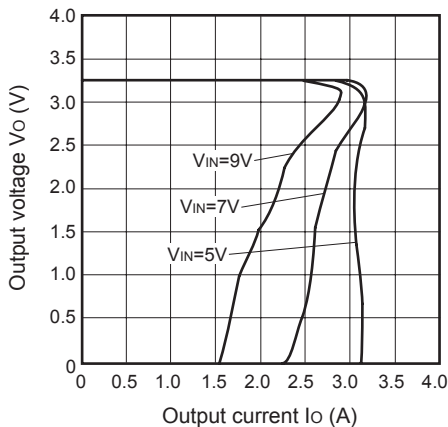

Fig.8 Output Voltage vs. Input Voltage (PQ015EF02SZH)

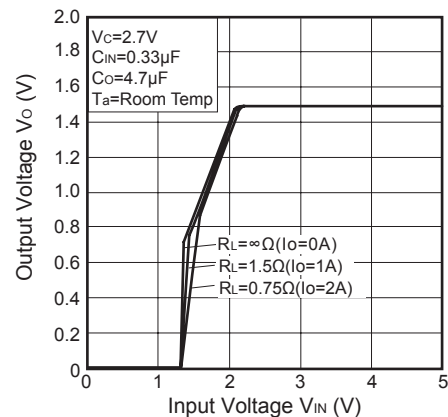

Fig.9 Output Voltage vs. Input Voltage (PQ018EF02SZH)

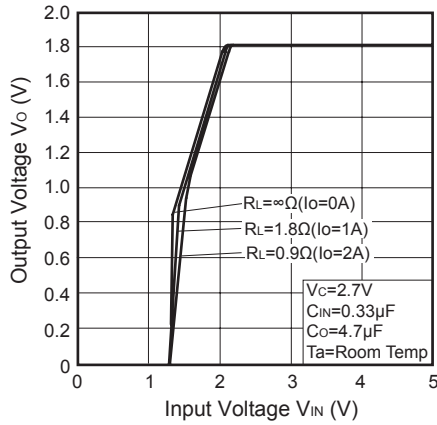

Fig.10 Output Voltage vs. Input Voltage (PQ025EF02SZH)

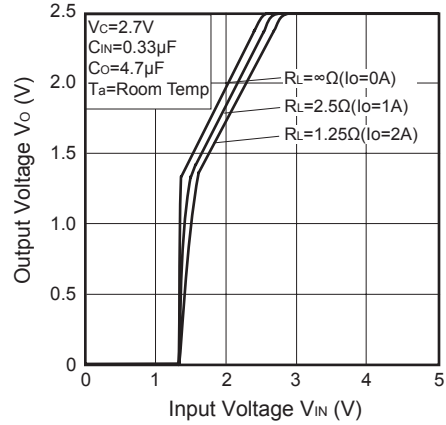

Fig.11 Output Voltage vs. Input Voltage (PQ033EF02SZH)

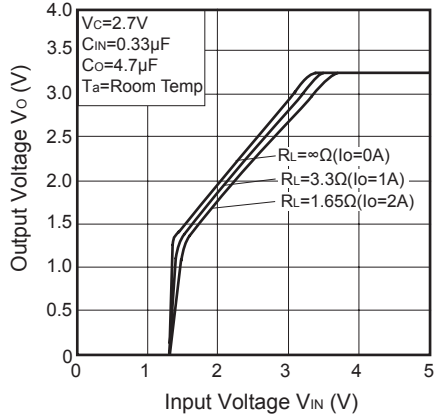

Fig.12 Circuit Operating Current vs. Input Voltage (PQ015EF02SZH)

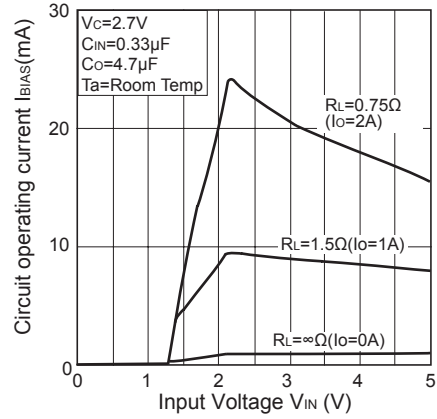

Fig.13 Circuit Operating Current vs. Input Voltage (PQ018EF02SZH)

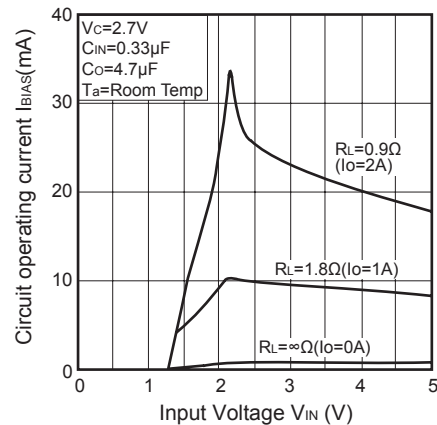

Fig.14 Circuit Operating Current vs. Input Voltage (PQ025EF02SZH)

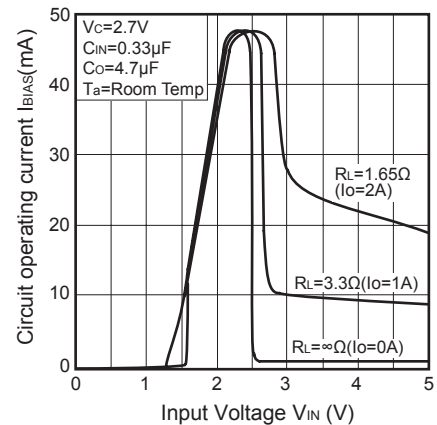

Fig.15 Circuit Operating Current vs. Input Voltage (PQ033EF02SZH)

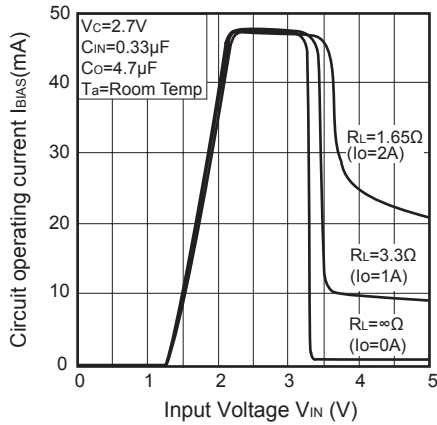

Fig.16 Dropout Voltage vs. Output Current (PQ033EF02SZH)

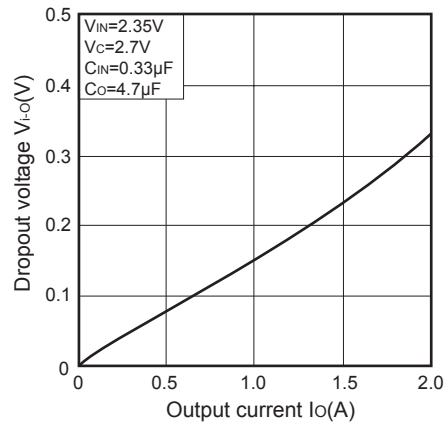

Fig.17 Output Voltage vs. Ambient Temperature (PQ018EF02SZH)

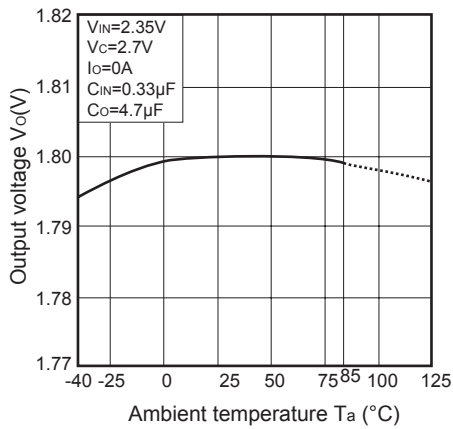

Fig.18 Quiescent Current vs. Ambient Temperature (PQ018EF02SZH)

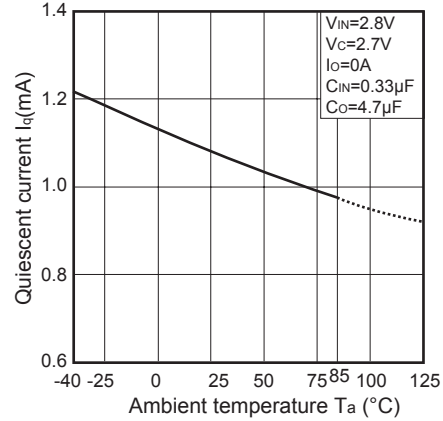
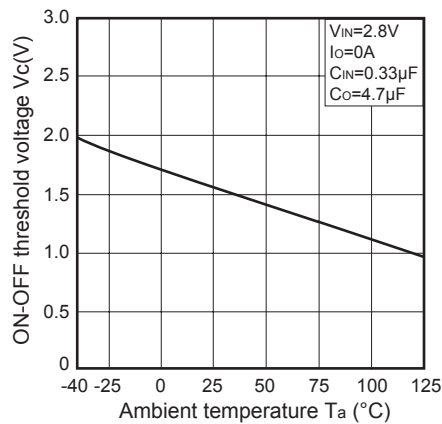
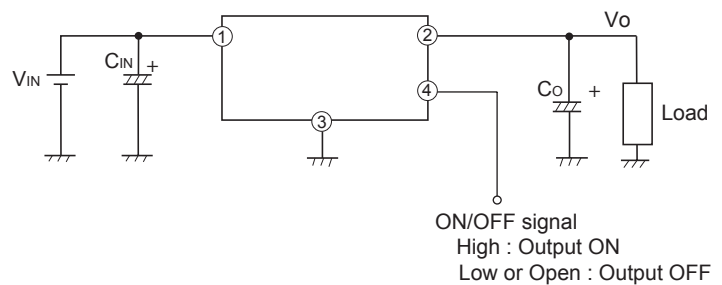

Fig.19 ON/OFF Threshold Voltage vs. Ambient Temperature (PQ018EF02SZH)



### Typical Application



## Looking for pricing, stock, or lifecycle information?

Click below to explore more details on WIN SOURCE:

-  [View PQ033EF02SZH on WIN SOURCE](#)
-  [Sharp Microelectronics](#) Information

## Optimize Your Supply Chain with WIN SOURCE Solutions

-  Global Sourcing Solution
-  Obsolete Management
-  Cost Control Management
-  Shortage Management
-  Alternative Solution
-  Excess Inventory Management