



THE DATASHEET OF MAX675EPA+





+5V Precision Voltage Reference

MAX675

General Description

The MAX675 is a precision voltage reference that is pretrimmed to within $\pm 0.15\%$ of 5V. The reference features excellent temperature stability (as low as 12.0ppm/ $^{\circ}\text{C}$ guaranteed), low current drain and low noise. It is supplied in the space-saving narrow SO package, as well as, the standard 8-pin Plastic DIP package.

Features

- ◆ Pretrimmed to +5V, $\pm 0.15\%$
- ◆ Excellent Temperature Stability: 12ppm/ $^{\circ}\text{C}$
- ◆ Low Noise: 10 $\mu\text{Vp-p}$
- ◆ Low Supply Current: 1.4mA (max)
- ◆ Short-Circuit Protected
- ◆ Load Regulation 0.001%/mA
- ◆ Pin-for-Pin Compatible with REF02

Applications

- A/D Converters
- D/A Converters
- Digital Voltmeters
- Voltage Regulators
- Threshold Detectors

Ordering Information

PART	TEMP RANGE	PIN-PACKAGE	TEMPCO (ppm/ $^{\circ}\text{C}$)	INITIAL ERROR (mV)
MAX675CPA	0 $^{\circ}\text{C}$ to +70 $^{\circ}\text{C}$	8 PDIP	12	7
MAX675CSA	0 $^{\circ}\text{C}$ to +70 $^{\circ}\text{C}$	8 Narrow SO	12	7
MAX675EPA	-40 $^{\circ}\text{C}$ to +85 $^{\circ}\text{C}$	8 PDIP	15	7
MAX675ESA	-40 $^{\circ}\text{C}$ to +85 $^{\circ}\text{C}$	8 Narrow SO	15	7

Ordering Information continued at end of data sheet.

Pin Configurations

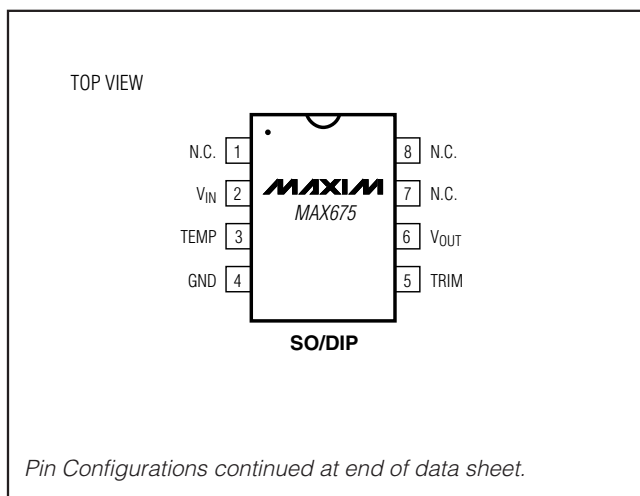

Typical Operating Circuit

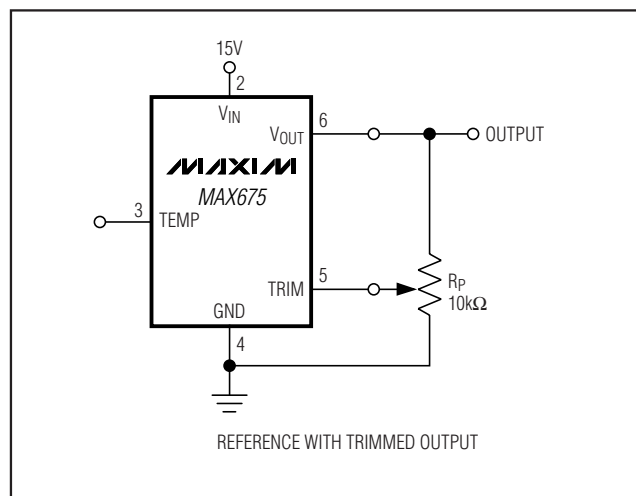

+5V Precision Voltage Reference

ABSOLUTE MAXIMUM RATINGS

Input Voltage	40V	Operating Temperature Range	
Power Dissipation		MAX675C	0°C to +70°C
TO-99 (TV) (derate at 7.1mW/ C above +80°C).....	500mW	MAX675E	-40°C to +85°C
CERDIP (J) (derate at 6.7mW/ C above +75°C).....	500mW	MAX675M	-55°C to +125°C
Plastic DIP (P) (derate at 5.6mW/ C above +36°C)	500mW	Dice Junction Temperature (T _J)	-65°C to +150°C
Narrow SO (S) (derate at 5.0mW/ C above +55°C)	300mW	Output Short-Circuit Duration	
Storage Temperature Range	-65°C to +150°C	(to Ground or V _{IN}).....	Indefinite
		Lead Temperature (soldering, 60s)	+300°C

Stresses beyond those listed under "Absolute Maximum Ratings" may cause permanent damage to the device. These are stress ratings only, and functional operation of the device at these or any other conditions beyond those indicated in the operational sections of the specifications is not implied. Exposure to absolute maximum rating conditions for extended periods may affect device reliability.

ELECTRICAL CHARACTERISTICS

(V_{IN} = +15V, T_A = +25°C, unless otherwise noted.)

PARAMETER	SYMBOL	CONDITIONS	MIN	TYP	MAX	UNITS
Output Voltage Tolerance		I _L = 0mA			±7	mV
Output Voltage Temperature Coefficient (Note 1)	TCV _O	MAX675CTV/CPA/CSA			12	ppm/°C
		MAX675ETV/EJA/EPA/ESA			15	
		MAX675MTV/MJA			20	
Output Adjustment Range	V _{TRIM}	R _p = 10	±150	±300		mV
Line Regulation (Note 2)		V _{IN} = 18V to 33V		0.006	0.01	%/V
Load Regulation (Note 2)		I _L = 0 to 10mA		0.001	0.002	%/mA
Turn-On Settling Time	t _{ON}	To ±0.1% of final value		5		µs
Quiescent Supply Current	I _Q	No load		750	1400	µA
Noise (Note 3)	e _{N(P-P)}	0.1Hz to 10Hz		10	15	µVP-P
Sink Current	I _S		0.3	0.5		mA
Short-Circuit Current	I _{SC}	V _{OUT} = 0V		30		mA
Current Temperature Voltage Output	V _T	(Note 4)		630		mV

Note 1: Temperature Coefficient is measured by the "box" method, i.e., the maximum ΔV_{OUT} is divided by ΔT .

Note 2: Line and Load Regulation specifications include the effect of self-heating.

Note 3: Guaranteed by design for MAX675CPA, MAX675CSA, MAX675EPA, MAX675ESA; sample tested for all other grades and packages.

Note 4: Limit current in or out of pin 3 to 50nA and capacitance on pin 3 to 30pF.

+5V Precision Voltage Reference

MAX675

Output Adjustment

The MAX675 trim terminal can be used to adjust the output voltage over a $5V \pm 150mV$ range. This feature allows system errors to be trimmed by setting the reference to a voltage other than 5V such as 5.120V for binary applications (see *Typical Operating Circuit*). The trim terminal may, of course, be left open if no adjustment is needed.

Adjustment of the output does not significantly affect the temperature performance of the device. The temperature coefficient change is approximately $0.7ppm/^\circ C$ for each 100mV of output adjustment from its initial value.

Temperature Voltage Output

The MAX675 provides a temperature-dependent output voltage on the TEMP pin. This voltage is proportional to the absolute temperature, and has a scale factor of approximately $2.1mV/^\circ C$ (Figure 2).

$$\text{Output Voltage} = 2.1(T + 273)mV$$

where T = Temperature in $^\circ C$

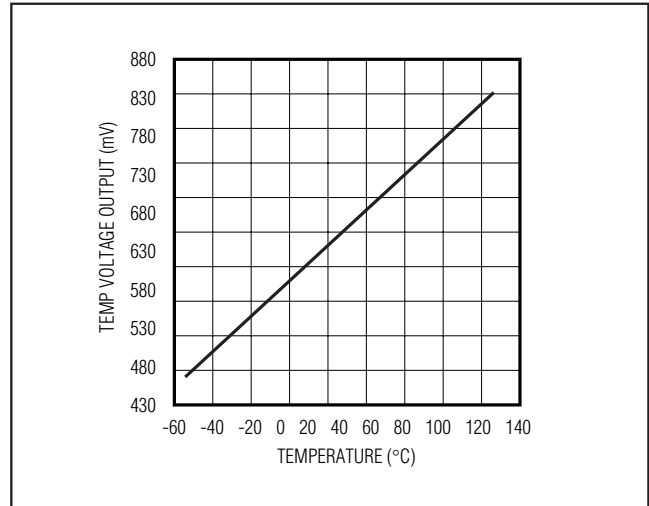
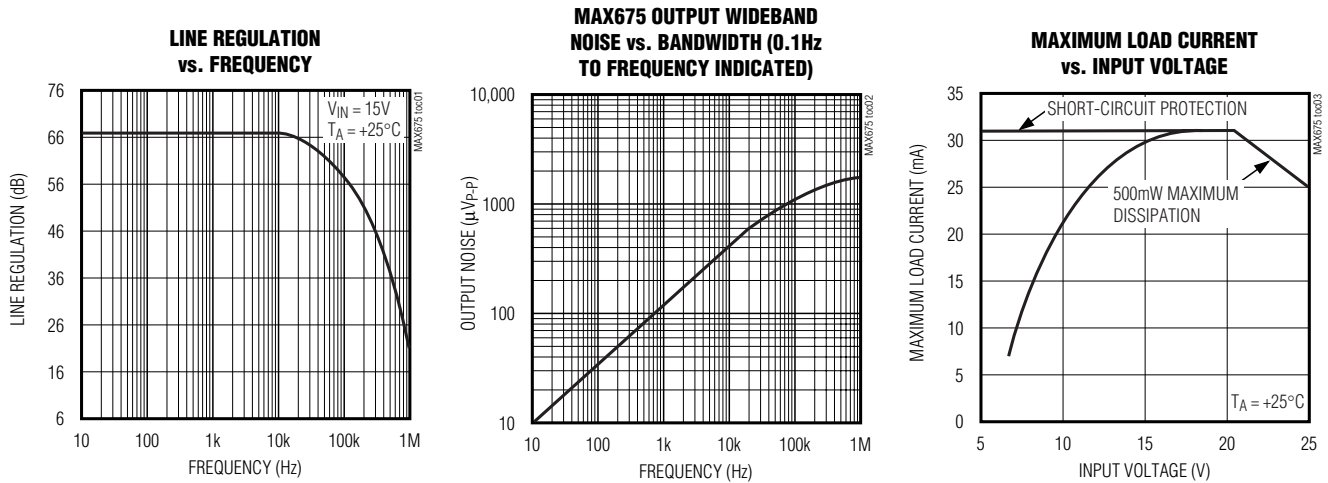

Figure 2. MAX675 Temperature Voltage Output vs. Temperature

Typical Operating Characteristics

($T_A = +25^\circ C$, unless otherwise noted.)



+5V Precision Voltage Reference

Typical Operating Characteristics (continued)

($T_A = +25^\circ\text{C}$, unless otherwise noted.)

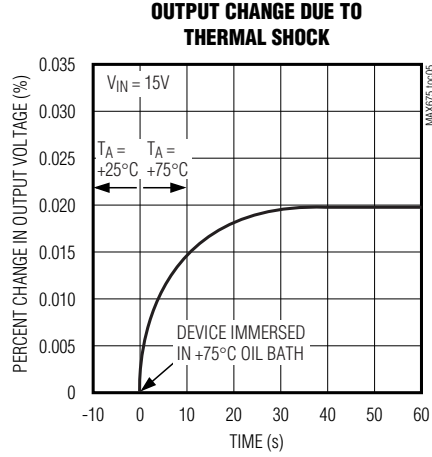
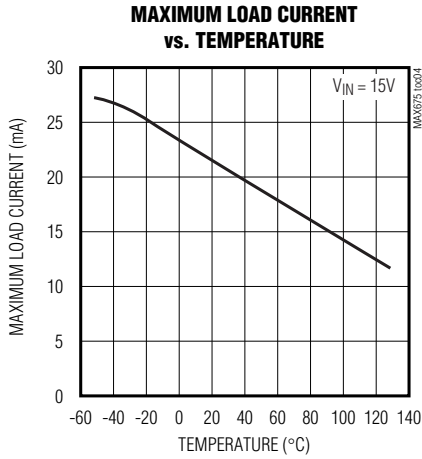

Typical Applications

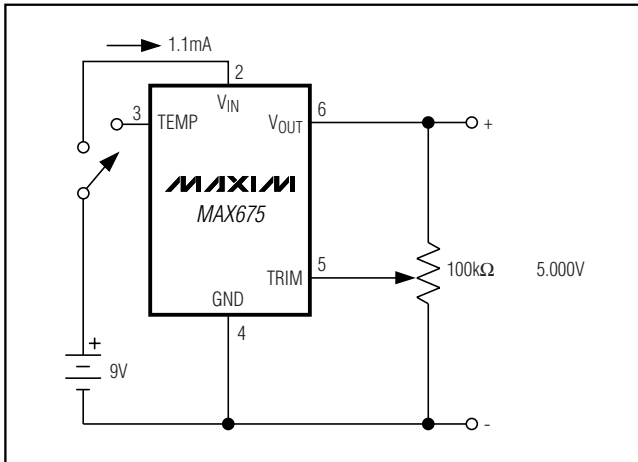

Figure 3. Precision Calibration Standard

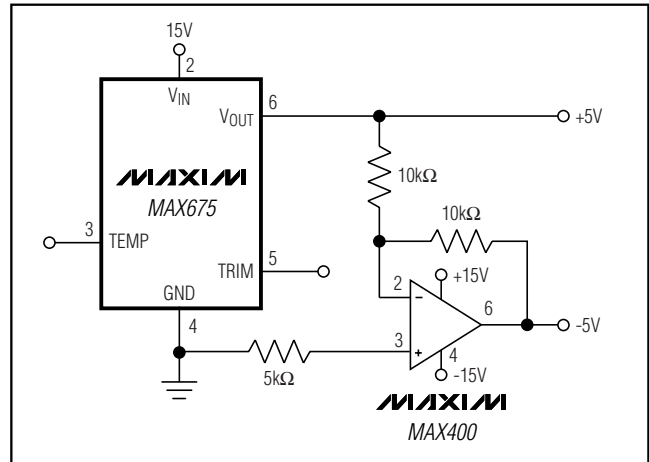

Figure 4. ±5V Reference

+5V Precision Voltage Reference

MAX675

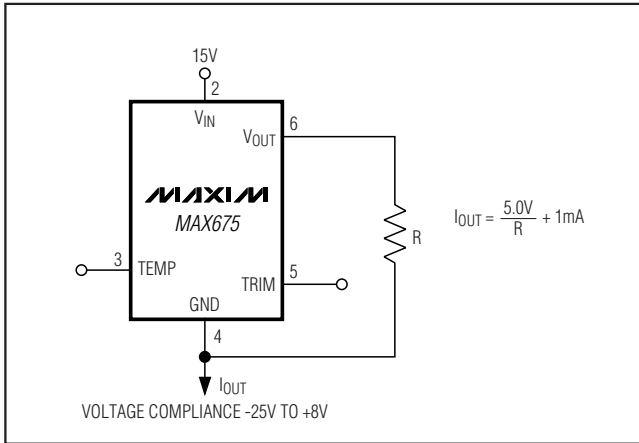

Figure 5. Current Source

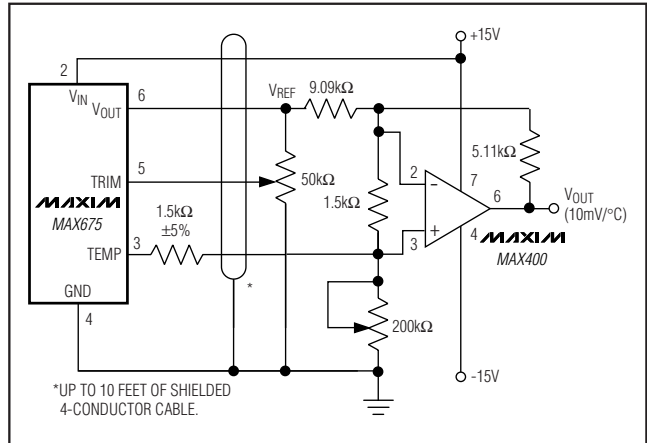
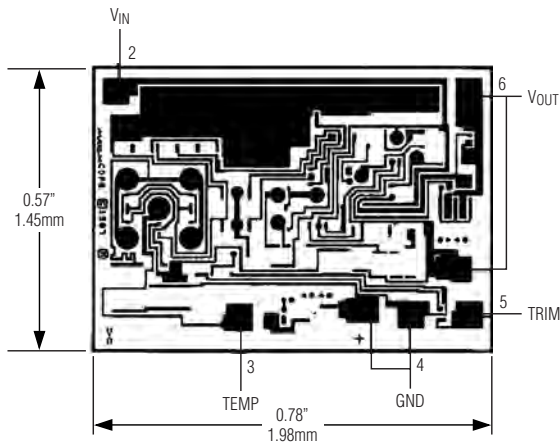
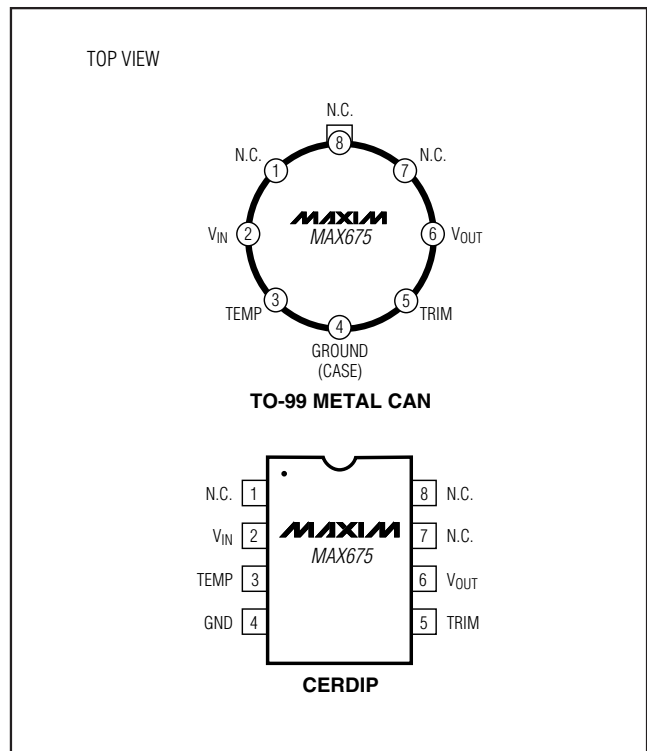

Figure 6. Precision Temperature Transducer with Remote Sensor

Chip Topography



Pin Configurations (continued)



Ordering Information

PART	TEMP RANGE	PIN-PACKAGE	TEMPCO (ppm/°C)	INITIAL ERROR (mV)
MAX675CTV*	0°C to +70°C	8 TO-99	12	7
MAX675ETV*	-40°C to +85°C	8 TO-99	15	7
MAX675EJA*	-40°C to +85°C	8 CERDIP	15	7
MAX675MTV*	-55°C to +125°C	8 TO-99	20	7
MAX675MJA*	-55°C to +125°C	8 CERDIP	20	7

*Contact factory for availability. Not recommended for new designs.

Maxim cannot assume responsibility for use of any circuitry other than circuitry entirely embodied in a Maxim product. No circuit patent licenses are implied. Maxim reserves the right to change the circuitry and specifications without notice at any time.

Maxim Integrated Products, 120 San Gabriel Drive, Sunnyvale, CA 94086 408-737-7600 5

Looking for pricing, stock, or lifecycle information?

Click below to explore more details on WIN SOURCE:

- ⊖ [View MAX675EPA+](#) on WIN SOURCE
- ⊖ [Maxim Integrated](#) Information

Optimize Your Supply Chain with WIN SOURCE Solutions

- ✓ Global Sourcing Solution
- ✓ Obsolete Management
- ✓ Cost Control Management
- ✓ Shortage Management
- ✓ Alternative Solution
- ✓ Excess Inventory Management