



**THE DATASHEET OF
MAX312LCUE+**





10Ω, Quad, SPST, +3V Logic-Compatible Analog Switches

MAX312L/MAX313L/MAX314L

General Description

Maxim's MAX312L/MAX313L/MAX314L analog switches feature low on-resistance (10Ω max) and 1.5Ω on-resistance matching between channels. These switches are +3V logic compatible when powered from ±15V or +12V supplies. The switches conduct equally well in either direction, and offer low leakage over temperature (2.5nA at +85°C).

The MAX312L/MAX313L/MAX314L are quad, single-pole/single-throw (SPST) analog switches. The MAX312L is normally closed (NC), and the MAX313L is normally open (NO). The MAX314L has two NC switches and two NO switches. All three devices operate from a single +4.5V to +36V supply or from dual ±4.5V to ±20V, and are available in 16-pin TSSOP, SO, and DIP packages.

Applications

- Test Equipment
- Communication Systems
- PBX, PABX Systems
- Audio Signal Routing
- Avionics
- Sample-and-Hold Circuits
- Data-Acquisition Systems
- xDSL Modems

Features

- ◆ +3V Logic-Compatible Digital Inputs
V_{IH} = 2.0V
V_{IL} = 0.8V
- ◆ Pin Compatible with MAX312/MAX313/MAX314 and DG411/DG412/DG413
- ◆ Low On-Resistance (10Ω max)
- ◆ Guaranteed R_{ON} Match Between Channels (1.5Ω max)
- ◆ Guaranteed R_{ON} Flatness over Specified Signal Range (2Ω max)
- ◆ Crosstalk > 96dB at 20kHz
- ◆ Single-Supply Operation: +4.5V to +36V
Dual-Supply Operation: ±4.5V to ±20V
- ◆ Rail-to-Rail Signal Handling

Ordering Information

PART	TEMP RANGE	PIN-PACKAGE
MAX312LCUE	0°C to +70°C	16 TSSOP
MAX312LCSE	0°C to +70°C	16 Narrow SO
MAX312LCPE	0°C to +70°C	16 Plastic DIP
MAX312LEUE	-40°C to +85°C	16 TSSOP
MAX312LESE	-40°C to +85°C	16 Narrow SO
MAX312LEPE	-40°C to +85°C	16 Plastic DIP
MAX312LETP	-40°C to +85°C	20 Thin QFN-EP*

*EP = Exposed pad.

Ordering Information continued at end of data sheet.

Pin Configurations

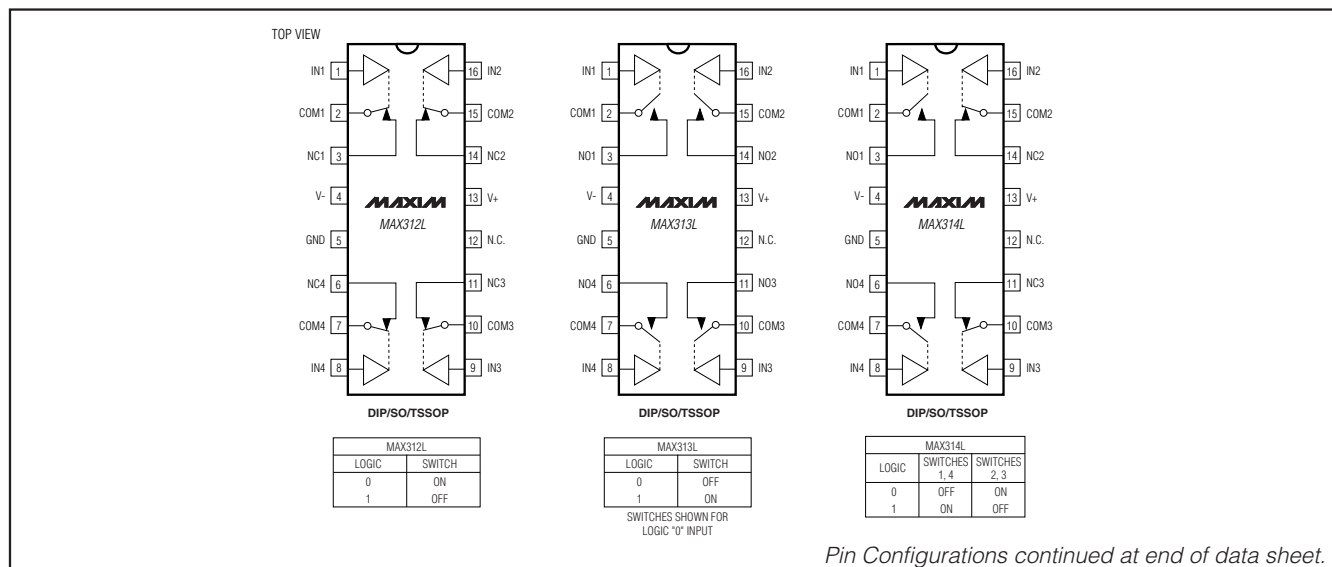

Pin Configurations continued at end of data sheet.



10 Ω , Quad, SPST, +3V Logic-Compatible Analog Switches

ABSOLUTE MAXIMUM RATINGS

(Voltages Referenced to GND)

V+	-0.3V to +44V
V-	+0.3V to -44V
V+ to V-	-0.3V to +44V
V _{IN} to V-	-0.3V to +44V
All Other Pins (Note 1)	(V- - 0.3V) to (V+ + 0.3V)
Continuous Current (COM ₋ , NO ₋ , NC ₋)	±100mA
Peak Current (COM ₋ , NO ₋ , NC ₋) (pulsed at 1ms, 10% duty cycle max)	±300mA

Continuous Power Dissipation (T_A = +70°C)

TSSOP (derate 6.7mW/°C above +70°C)	457mW
Narrow SO (derate 8.70mW/°C above +70°C)	696mW
Plastic DIP (derate 10.53mW/°C above +70°C)	842mW
Thin QFN (derate 21.3mW/°C above +70°C)	1702.1mW
Operating Temperature Ranges	
MAX31 _{LC} _E	0°C to +70°C
MAX31 _{LE} _E	-40°C to +85°C
Storage Temperature Range	-65°C to +150°C
Junction Temperature	+150°C
Lead Temperature (soldering, 10s)	+300°C

Note 1: Signals on COM₋, NO₋, or NC₋ exceeding V+ or V- are clamped by internal diodes. Limit forward-diode current to maximum current rating.

Stresses beyond those listed under "Absolute Maximum Ratings" may cause permanent damage to the device. These are stress ratings only, and functional operation of the device at these or any other conditions beyond those indicated in the operational sections of the specifications is not implied. Exposure to absolute maximum rating conditions for extended periods may affect device reliability.

ELECTRICAL CHARACTERISTICS—Dual Supplies

(V+ = +15V, V- = -15V, GND = 0, V_{IH} = 2.0V, V_{IL} = 0.8V, T_A = T_{MIN} to T_{MAX}, unless otherwise noted. Typical values are at T_A = +25°C.) (Notes 2, 3)

PARAMETER	SYMBOL	CONDITIONS	T _A	MIN	TYP	MAX	UNITS
ANALOG SWITCH							
Analog Signal Range	V _{COM-} , V _{NO-} , V _{NC-}			V-		V+	V
On-Resistance	R _{ON}	I _{COM-} = 10mA, V _{NO-} or V _{NC-} = ±10V	+25°C	6.5	10		Ω
			T _{MIN} to T _{MAX}			15	
On-Resistance Match Between Channels (Note 4)	Δ R _{ON}	I _{COM-} = 10mA, V _{NO-} or V _{NC-} = ±10V	+25°C	0.3	1.5		Ω
			T _{MIN} to T _{MAX}			3	
On-Resistance Flatness (Note 5)	R _{FLAT(ON)}	I _{COM-} = 10mA, V _{NO-} or V _{NC-} = -5V, 0, 5V	+25°C	0.2	2		Ω
			T _{MIN} to T _{MAX}			4	
Off-Leakage Current (NO ₋ or NC ₋) (Note 6)	I _{NO} I _{NC}	V _{COM-} = +10V, V _{NO-} or V _{NC-} = ±10V	+25°C	-0.5	-0.02	0.5	nA
			T _{MIN} to T _{MAX}	-2.5		2.5	
COM Off-Leakage Current (Note 6)	I _{COM(OFF)}	V _{COM-} = ±10V, - V _{NO-} or V _{NC-} = +10V	+25°C	-0.5	-0.02	0.5	nA
			T _{MIN} to T _{MAX}	-2.5		2.5	
COM On-Leakage Current (Note 6)	I _{COM(ON)}	V _{NO-} or V _{NC-} = ±10V, V _{COM-} = ±10V	+25°C	-1	-0.04	1	nA
			T _{MIN} to T _{MAX}	-5		5	
DYNAMIC							
Turn-On Time	t _{ON}	V _{COM-} = ±10V, R _L = 300 Ω , C _L = 35pF, Figure 1	+25°C	115	225		ns
			T _{MIN} to T _{MAX}			275	
Turn-Off Time	t _{OFF}	V _{COM-} = ±10V, R _L = 300 Ω , C _L = 35pF, Figure 1	+25°C	100	185		ns
			T _{MIN} to T _{MAX}			235	
Break-Before-Make Time Delay (MAX314L only, Note 7)	t _D	R _L = 300 Ω , C _L = 35pF, Figure 2	+25°C	1	10		ns
Charge Injection (Note 7)	Q	V _{GEN} = 0, R _{GEN} = 0, C _L = 1.0nF, Figure 3	+25°C	-30	20	30	pC

10Ω, Quad, SPST, +3V Logic-Compatible Analog Switches

MAX312L/MAX313L/MAX314L

ELECTRICAL CHARACTERISTICS—Dual Supplies (continued)

(V+ = +15V, V- = -15V, GND = 0, V_{IH} = 2.0V, V_{IL} = 0.8V, T_A = T_{MIN} to T_{MAX}, unless otherwise noted. Typical values are at T_A = +25°C.) (Notes 2, 3)

PARAMETER	SYMBOL	CONDITIONS	T _A	MIN	TYP	MAX	UNITS
Off-Isolation (Note 8)	V _{ISO}	f = 1MHz, R _L = 50Ω, C _L = 5pF, Figure 4	+25°C		-75		dB
Crosstalk (Note 9)	V _{CT}	f = 1MHz, R _L = 50Ω, C _L = 5pF, Figure 5	+25°C		-85		dB
NC_ or NO_ Off-Capacitance	C _{OFF}	f = 1MHz, Figure 6	+25°C		15		pF
COM_ Off-Capacitance	C _{COM_ (OFF)}	f = 1MHz, Figure 6	+25°C		15		pF
On-Capacitance	C _{ON}	f = 1MHz, Figure 6	+25°C		47		pF
LOGIC INPUT							
Input Logic High	V _{IH}			2.0			V
Input Logic Low	V _{IL}					0.8	V
Input Current with Input Logic High	I _{INH}	IN_ = 2.0V		-0.5	0.005	0.5	μA
Input Current with Input Logic Low	I _{INL}	IN_ = 0.8V		-0.5	0.005	0.5	μA
POWER SUPPLY							
Power-Supply Range	V+, V-			±4.5		±20.0	V
Positive Supply Current	I+	V+ = +16.5V, V- = -16.5V, V _{IN} = 0 or V+	+25°C		0.01	1	μA
			T _{MIN} to T _{MAX}			5	
		V+ = +16.5V, V- = -16.5V, V _{IN} = 5V	+25°C		130	200	
			T _{MIN} to T _{MAX}			300	
Negative Supply Current	I-	V+ = +16.5V, V- = -16.5V, V _{IN} = 0 or 5V	+25°C			1	μA
			T _{MIN} to T _{MAX}			5	
Ground Current	I _{GND}	V+ = +16.5V, V- = -16.5V, V _{IN} = 0 or V+	+25°C		0.01	1	μA
			T _{MIN} to T _{MAX}			5	
		V+ = +16.5V, V- = -16.5V, V _{IN} = 5V	+25°C		130	200	
			T _{MIN} to T _{MAX}			300	

ELECTRICAL CHARACTERISTICS—Single Supply

(V+ = +12V, V- = 0, GND = 0, V_{IH} = 2.0V, V_{IL} = 0.8V, T_A = T_{MIN} to T_{MAX}, unless otherwise noted. Typical values are at T_A = +25°C.) (Notes 2, 3)

PARAMETER	SYMBOL	CONDITIONS	T _A	MIN	TYP	MAX	UNITS
ANALOG SWITCH							
Analog Signal Range	V _{COM_} , V _{NO_} , V _{NC_}			0		V+	V
On-Resistance	R _{ON}	I _{COM_} = 10mA, V _{NC_} or V _{NO_} = +10V	+25°C		12.5	25	Ω
			T _{MIN} to T _{MAX}			35	

10 Ω , Quad, SPST, +3V Logic-Compatible Analog Switches

ELECTRICAL CHARACTERISTICS—Single Supply (continued)

(V₊ = +12V, V₋ = 0, GND = 0, V_{IH} = 2.0V, V_{IL} = 0.8V, T_A = T_{MIN} to T_{MAX}, unless otherwise noted. Typical values are at T_A = +25°C.) (Notes 2, 3)

PARAMETER	SYMBOL	CONDITIONS	T _A	MIN	TYP	MAX	UNITS
On-Resistance Match Between Channels (Note 4)	ΔR_{ON}	I _{COM_} = 10mA, V _{NO_} or V _{NC_} = +10V	+25°C	0.3	2		Ω
			T _{MIN} to T _{MAX}			2.5	
On-Resistance Flatness (Note 5)	R _{FLAT(ON)}	I _{COM_} = 10mA, V _{NO_} or V _{NC_} = +2V, +6V, +10V	+25°C	1.7	3.5		Ω
			T _{MIN} to T _{MAX}			4.5	
DYNAMIC							
Turn-On Time	t _{ON}	V _{COM_} = 8V, R _L = 300 Ω , C _L = 35pF, Figure 1	+25°C	165	325		ns
			T _{MIN} to T _{MAX}			425	
Turn-Off Time	t _{OFF}	V _{COM_} = 8V, R _L = 300 Ω , C _L = 35pF, Figure 1	+25°C	117	175		ns
			T _{MIN} to T _{MAX}			225	
Break-Before-Make Time Delay (MAX314L only, Note 7)	t _D	R _L = 300 Ω , C _L = 35pF, Figure 2	+25°C	1	5		ns
Charge Injection	Q	Figure 3, C _L = 1.0nF, V _{GEN} = 0, R _{GEN} = 0	+25°C		-10		pC
LOGIC INPUT							
Input Logic High	V _{IH}			2.0			V
Input Logic Low	V _{IL}					0.8	V
Input Current with Input Logic High	I _{INH}	I _{N_} = 2.0V		-0.5	0.005	0.5	μ A
Input Current with Input Logic Low	I _{INL}	I _{N_} = 0.8V		-0.5	0.005	0.5	μ A
POWER SUPPLY							
Power-Supply Range	V ₊			+4.5		+36	V
Positive Supply Current	I ₊	V ₊ = +13.2V, V _{IN} = 0 or V ₊	+25°C	0.01	1		μ A
			T _{MIN} to T _{MAX}			5	
		V ₊ = +13.2V, V _{IN} = 5V	+25°C	25	125		
			T _{MIN} to T _{MAX}			175	

Note 2: The algebraic convention, where the most negative value is a minimum and the most positive value a maximum, is used in this data sheet.

Note 3: -40°C specifications are guaranteed by design.

Note 4: ΔR_{ON} = ΔR_{ON} max - ΔR_{ON} min.

Note 5: Flatness is defined as the difference between the maximum and minimum value of on-resistance as measured over the specified analog signal range.

Note 6: Leakage parameters are 100% tested at maximum-rated hot temperature and guaranteed by correlation at +25°C.

Note 7: Guaranteed by design.

Note 8: Off-isolation = $20\log_{10} [V_{COM}/(V_{NC}$ or $V_{NO})]$, V_{COM} = output, V_{NC} or V_{NO} = input to off switch.

Note 9: Between any two switches.

10Ω, Quad, SPST, +3V Logic-Compatible Analog Switches

Typical Operating Characteristics

($T_A = +25^\circ\text{C}$, unless otherwise noted.)

MAX312L/MAX313L/MAX314L

ON-RESISTANCE vs. V_{COM} (DUAL SUPPLIES)

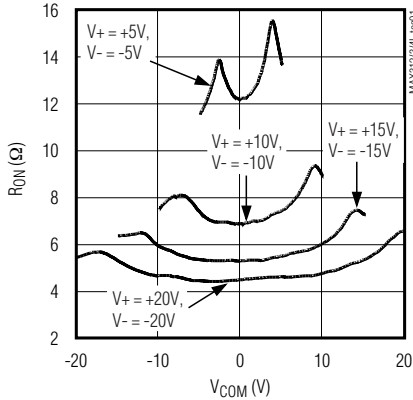

ON-RESISTANCE vs. V_{COM} (SINGLE SUPPLY)

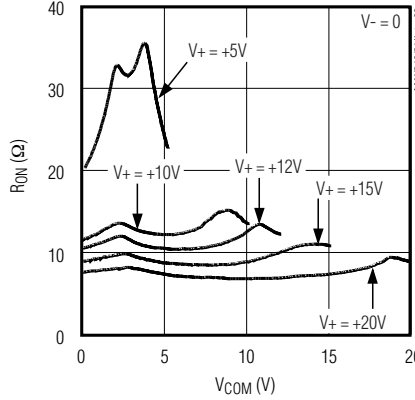

ON-RESISTANCE vs. V_{COM} AND TEMPERATURE (DUAL SUPPLIES)

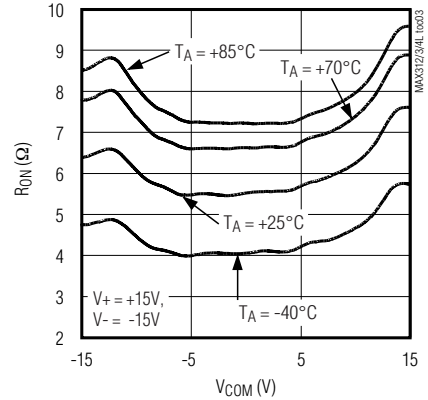

ON-RESISTANCE vs. V_{COM} AND TEMPERATURE (SINGLE SUPPLY)

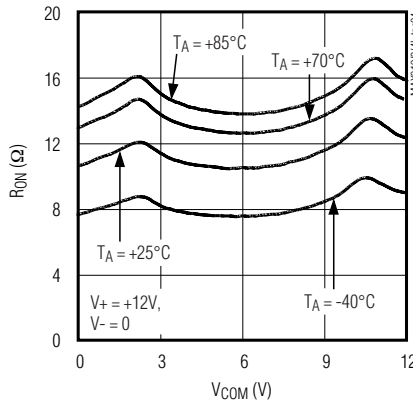

OFF- AND ON-LEAKAGE CURRENT vs. TEMPERATURE

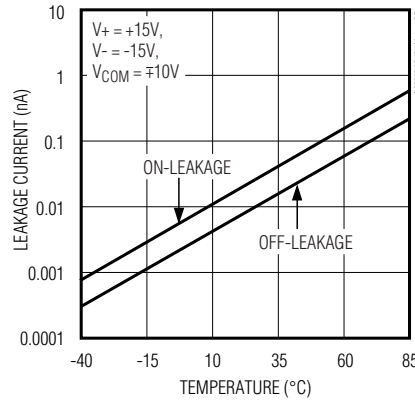

CHARGE INJECTION vs. V_{COM}

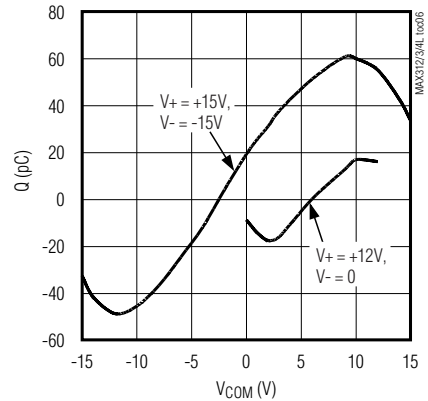

SUPPLY CURRENT vs. TEMPERATURE

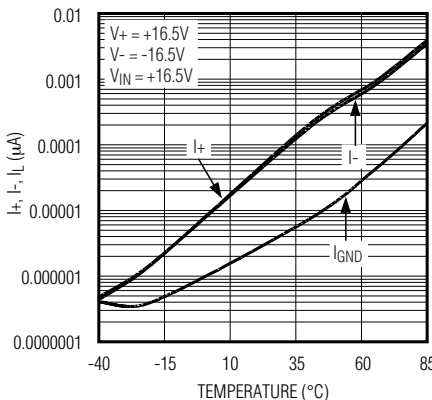

TOTAL HARMONIC DISTORTION vs. FREQUENCY

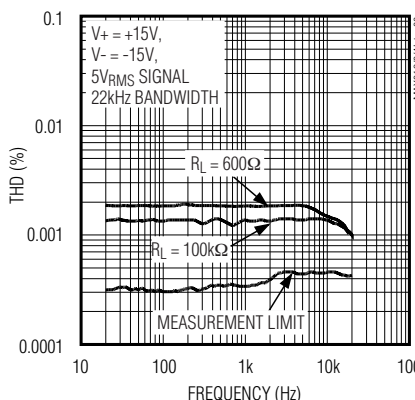

FREQUENCY RESPONSE

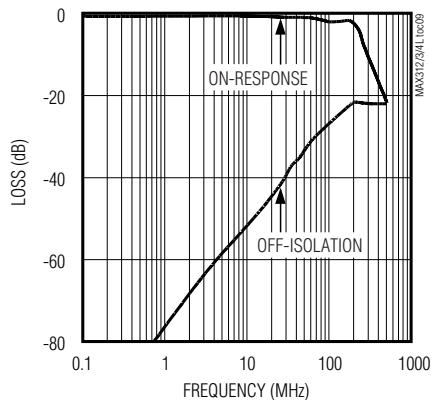

10Ω, Quad, SPST, +3V Logic-Compatible Analog Switches

Typical Operating Characteristics (continued)

($T_A = +25^\circ\text{C}$, unless otherwise noted.)

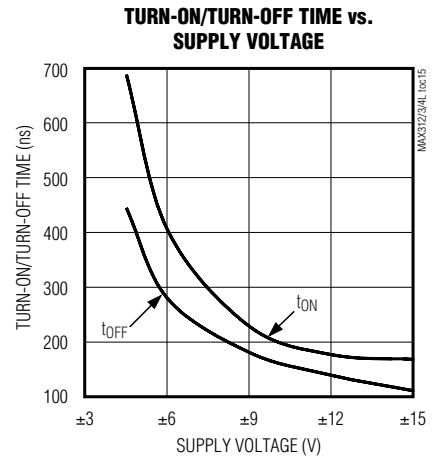
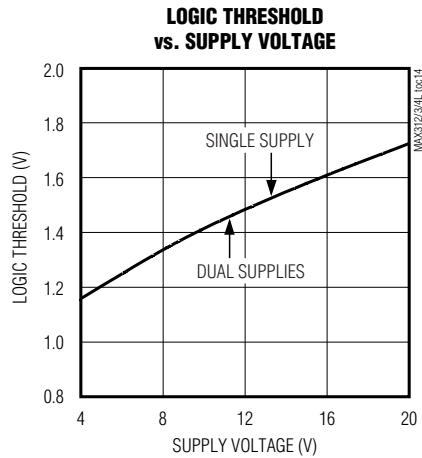
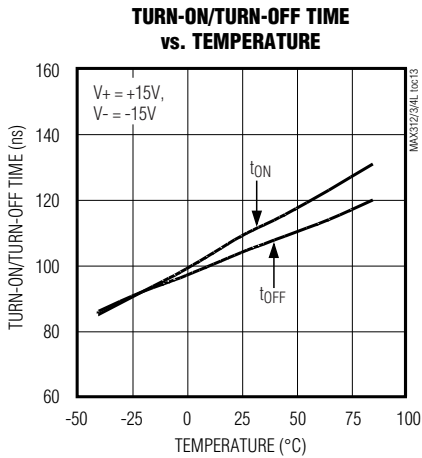
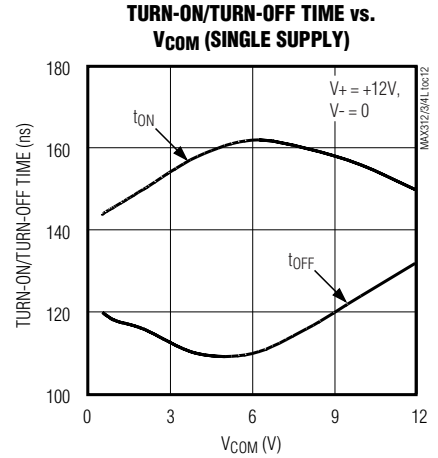

10Ω, Quad, SPST, +3V Logic-Compatible Analog Switches

Pin Descriptions

PIN (TSSOP, SO, DIP)			NAME	FUNCTION
MAX312L	MAX313L	MAX314L		
1, 8, 9, 16	1, 8, 9, 16	1, 8, 9, 16	IN1, IN4, IN3, IN2	Logic Inputs
2, 7, 10, 15	2, 7, 10, 15	2, 7, 10, 15	COM1, COM4, COM3, COM2	Analog Signal Common Terminals
3, 6, 11, 14	—	—	NC1, NC4, NC3, NC2	Analog Signal Normally Closed Terminals
—	3, 6, 11, 14	—	NO1, NO4, NO3, NO2	Analog Signal Normally Open Terminals
—	—	3, 6	NO1, NO4	Analog Signal Normally Open Terminals
—	—	11, 14	NC3, NC2	Analog Signal Normally Closed Terminals
4	4	4	V-	Negative Analog Supply Input (connect V- to GND for single-supply operation)
5	5	5	GND	Ground
12	12	12	N.C.	No Connection. Not internally connected.
13	13	13	V+	Positive Analog Supply Input

MAX312L/MAX313L/MAX314L

10 Ω , Quad, SPST, +3V Logic-Compatible Analog Switches

Pin Descriptions (continued)

PIN (TQFN)			NAME	FUNCTION
MAX312L	MAX313L	MAX314L		
7, 9, 17, 19	7, 9, 17, 19	7, 9, 17, 19	IN4, IN3, IN2, IN1	Logic Inputs
6, 10, 16, 20	6, 10, 16, 20	6, 10, 16, 20	COM4, COM3, COM2, COM1	Analog Signal Common Terminals
1, 5, 11, 15	—	—	NC1, NC4, NC3, NC2	Analog Signal Normally Closed Terminals
—	1, 5, 11, 15	—	NO1, NO4, NO3, NO2	Analog Signal Normally Open Terminals
—	—	1, 5	NO1, NO4	Analog Signal Normally Open Terminals
—	—	11, 15	NC3, NC2	Analog Signal Normally Closed Terminals
2	2	2	V-	Negative Analog Supply Input (connect to GND for single-supply operation)
4	4	4	GND	Ground
3, 8, 12, 13, 18	3, 8, 12, 13, 18	3, 8, 12, 13, 18	N.C.	No Connection. Not internally connected.
14	14	14	V+	Positive Analog Supply Input
—	—	—	EP	Exposed Pad. Connect EP to V+.

Applications Information

Low-Distortion Audio

The MAX312L/MAX313L/MAX314L, having very low R_{ON} and very low R_{ON} variation with signal amplitude, are well suited for low-distortion audio applications. The *Typical Operating Characteristics* show Total Harmonic Distortion (THD) vs. Frequency graphs for several signal amplitudes and impedances. Higher source and load impedances improve THD, but reduce off-isolation.

Off-Isolation at High Frequencies

In 50 Ω systems, the high-frequency on-response of these parts extends from DC to above 100MHz with a typical loss of -2dB. When the switch is turned off, however, it behaves like a capacitor, and off-isolation decreases with increasing frequency. (Above 300MHz, the switch actually passes more signal turned off than turned on.) This effect is more pronounced with higher source-and-load impedances.

Above 5MHz, circuit board layout becomes critical, and it becomes difficult to characterize the response of the switch independent of the circuit. The graphs shown in the *Typical Operating Characteristics* were taken using a 50 Ω source and load connected with BNC connectors.

Power-Supply Sequencing-Free Operation

Most CMOS switches require specific power-supply sequencing in order to prevent the devices from latching up. The older MAX312/MAX313/MAX314 devices require a proper power-supply sequence of V+, V_L, V-, and so forth. Otherwise, it becomes necessary to add signal diodes to the circuit in order to protect it from potential latchups. The new MAX312L/MAX313L/MAX314L devices eliminate the need for a V_L pin and permit the user to utilize any power-up sequence that is required. It is, however, important not to exceed the absolute maximum ratings because stresses beyond the listed ratings may cause permanent damage to the devices.

Chip Information

TRANSISTOR COUNT: 92

PROCESS: CMOS

10Ω, Quad, SPST, +3V Logic-Compatible Analog Switches

Test Circuits/Timing Diagrams

MAX312L/MAX313L/MAX314L

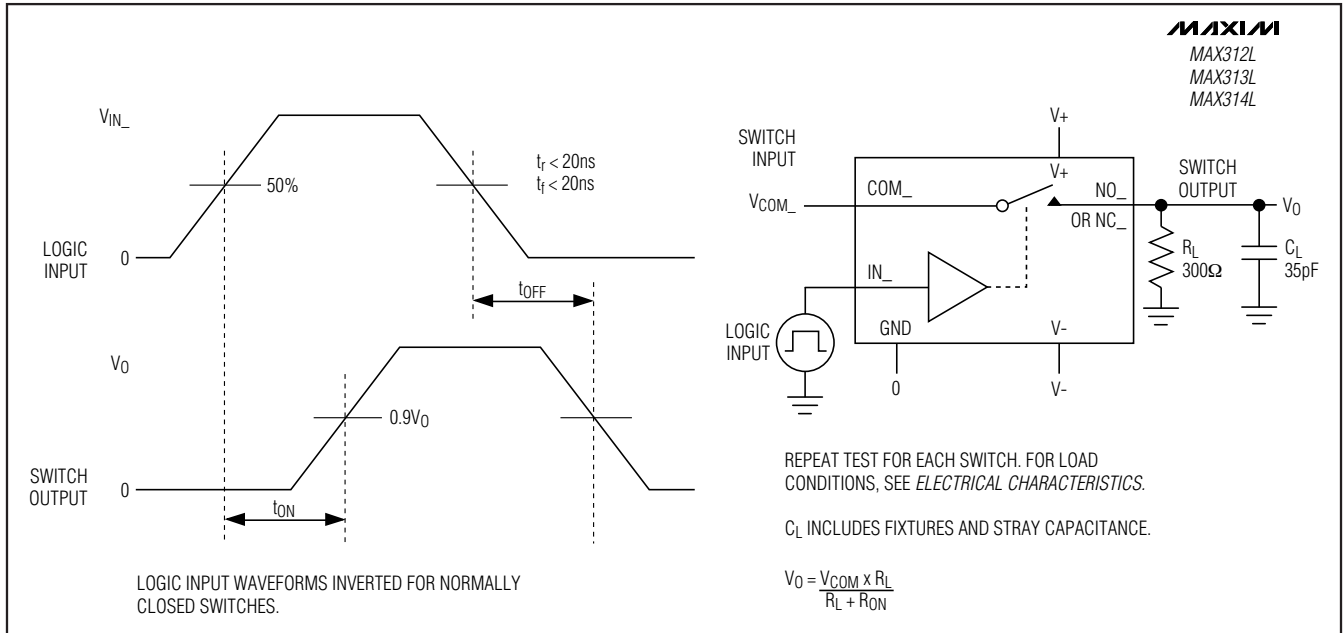

Figure 1. Switching-Time Test Circuit

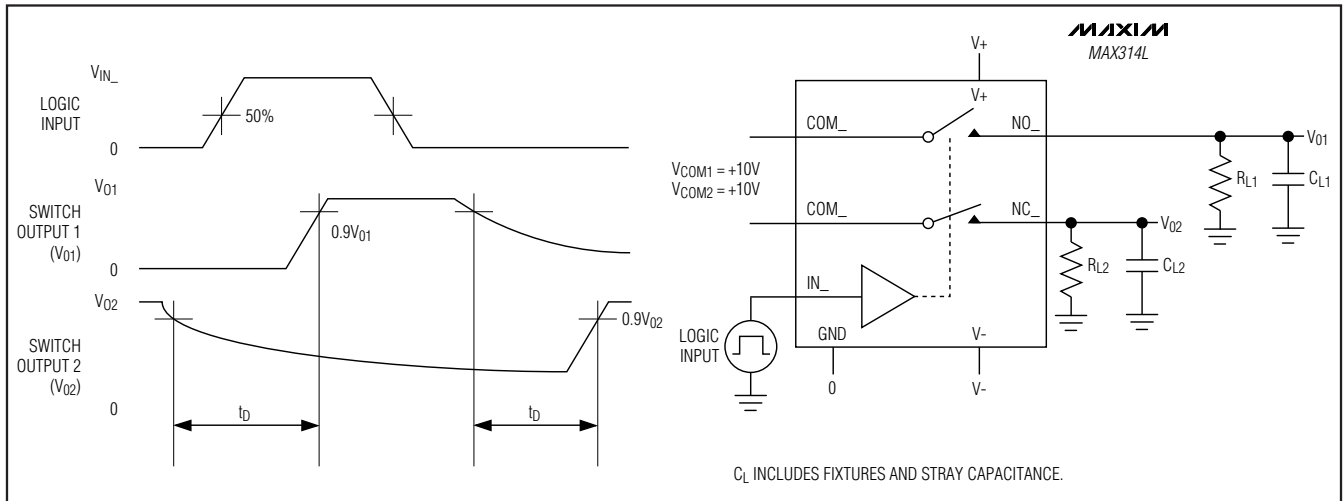

Figure 2. Break-Before-Make Test Circuit (MAX314L Only)

10Ω, Quad, SPST, +3V Logic-Compatible Analog Switches

Test Circuits/Timing Diagrams (continued)

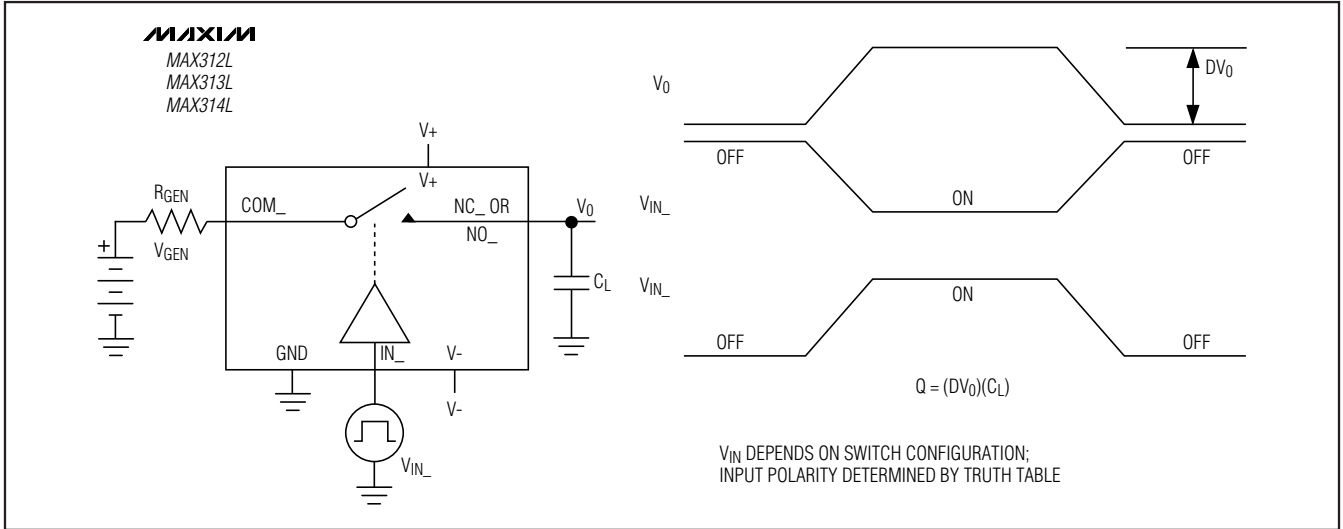

Figure 3. Charge Injection Test Circuit

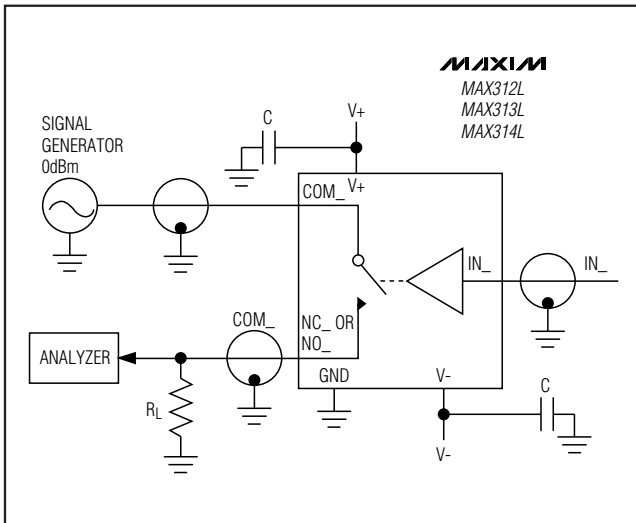

Figure 4. Off-Isolation Test Circuit

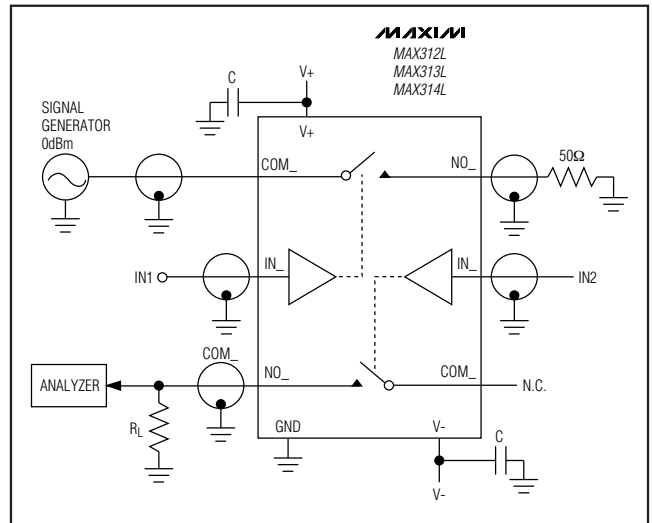

Figure 5. Crosstalk Test Circuit

10Ω, Quad, SPST, +3V Logic-Compatible Analog Switches

Test Circuits/Timing Diagrams (continued)



Figure 6. Channel Off-Capacitance Test Circuit



Figure 7. Channel On-Capacitance Test Circuit

Ordering Information (continued)

PART	TEMP RANGE	PIN-PACKAGE
MAX313LCUE	0°C to +70°C	16 TSSOP
MAX313LCSE	0°C to +70°C	16 Narrow SO
MAX313LCPE	0°C to +70°C	16 Plastic DIP
MAX313LEUE	-40°C to +85°C	16 TSSOP
MAX313LESE	-40°C to +85°C	16 Narrow SO
MAX313LEPE	-40°C to +85°C	16 Plastic DIP
MAX313LETP	-40°C to +85°C	20 Thin QFN-EP*
MAX314LCUE	0°C to +70°C	16 TSSOP
MAX314LCSE	0°C to +70°C	16 Narrow SO
MAX314LCPE	0°C to +70°C	16 Plastic DIP
MAX314LEUE	-40°C to +85°C	16 TSSOP
MAX314LESE	-40°C to +85°C	16 Narrow SO
MAX314LEPE	-40°C to +85°C	16 Plastic DIP
MAX314LETP	-40°C to +85°C	20 Thin QFN-EP*

*EP = Exposed pad.

MAX312L/MAX313L/MAX314L

10Ω, Quad, SPST, +3V Logic-Compatible Analog Switches

Pin Configurations (continued)

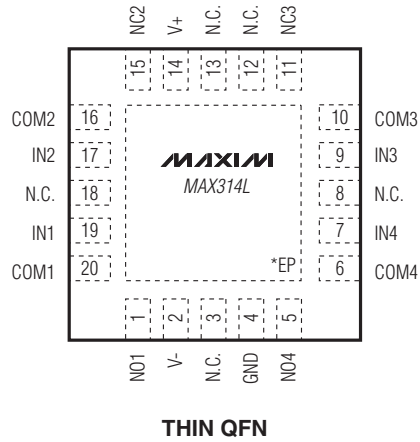
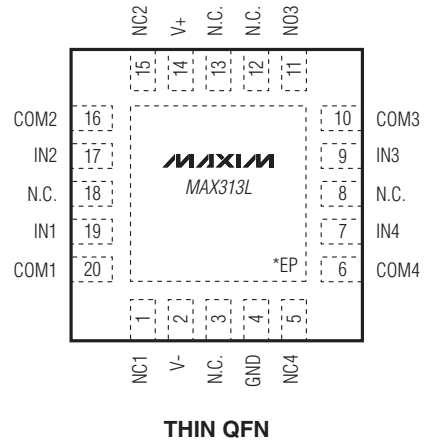
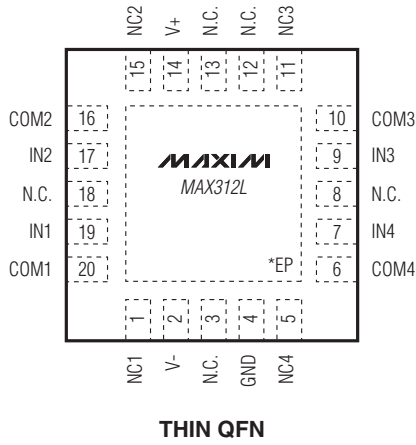

*EP = EXPOSED PAD. CONNECT TO V+.

10Ω, Quad, SPST, +3V Logic-Compatible Analog Switches

Package Information

For the latest package outline information and land patterns, go to www.maxim-ic.com/packages.

PACKAGE TYPE	PACKAGE CODE	DOCUMENT NO.
16 TSSOP	U16-1	21-0066
16 Narrow SO	S16-8	21-0041
16 Plastic DIP	P16-2	21-0043
20 TQFN	T2055-5	21-0140

MAX312L/MAX313L/MAX314L

10Ω, Quad, SPST, +3V Logic-Compatible Analog Switches

Revision History

REVISION NUMBER	REVISION DATE	DESCRIPTION	PAGES CHANGED
0	10/01	Initial release.	—
1	9/08	Added the TQFN package.	1, 2, 8, 11, 12, 13

Maxim cannot assume responsibility for use of any circuitry other than circuitry entirely embodied in a Maxim product. No circuit patent licenses are implied. Maxim reserves the right to change the circuitry and specifications without notice at any time.

14 **Maxim Integrated Products, 120 San Gabriel Drive, Sunnyvale, CA 94086 408-737-7600**

Looking for pricing, stock, or lifecycle information?

Click below to explore more details on WIN SOURCE:

- ⊖ [View MAX312LCUE+ on WIN SOURCE](#)
- ⊖ [Maxim Integrated Information](#)

Optimize Your Supply Chain with WIN SOURCE Solutions

- ✓ Global Sourcing Solution
- ✓ Obsolete Management
- ✓ Cost Control Management
- ✓ Shortage Management
- ✓ Alternative Solution
- ✓ Excess Inventory Management