



**THE DATASHEET OF  
TLV70130DBVR**



## 24-V Input Voltage, 150-mA, Ultralow I<sub>Q</sub> Low-Dropout Regulators

### FEATURES

- **Wide Input Voltage Range: 2.5 V to 24 V**
- **Low 3.2- $\mu$ A Quiescent Current**
- **Ground Pin Current: 3.4  $\mu$ A at 100-mA I<sub>OUT</sub>**
- **Stable with Any Capacitor (> 0.47  $\mu$ F)**
- **Available in SOT23-5 Package**
- **Operating Junction Temperature:  
–40°C to +125°C**

### APPLICATIONS

- **Ultralow Power Microcontrollers**
- **E-Meters**
- **Fire Alarms/Smoke Detector Systems**
- **Handset Peripherals**
- **Industrial/Automotive Applications**
- **Remote Controllers**
- **Zigbee™ Networks**
- **PDA's**
- **Portable, Battery-Powered Equipment**

### DESCRIPTION

The TLV701xx series of low-dropout (LDO) regulators are ultralow quiescent current devices designed for extremely power-sensitive applications. Quiescent current is virtually constant over the complete load current and ambient temperature range. These devices are an ideal power management attachment to low-power microcontrollers, such as the [MSP430](#).

The TLV701xx operates over a wide operating input voltage of 2.5 V to 24 V. Thus, it is an excellent choice for both battery-powered systems as well as industrial applications that see large line transients.

The TLV701xx is available in a 3-mm × 3-mm SOT23-5 package that is ideal for cost-effective board manufacturing.

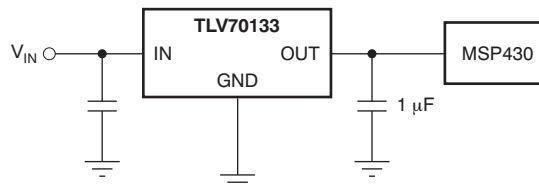
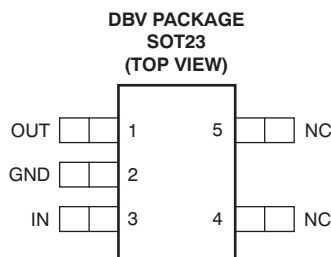
**PRODUCT PREVIEW**

Please be aware that an important notice concerning availability, standard warranty, and use in critical applications of Texas Instruments semiconductor products and disclaimers thereto appears at the end of this data sheet.

ZigBee is a trademark of ZigBee Alliance.

All other trademarks are the property of their respective owners.



This integrated circuit can be damaged by ESD. Texas Instruments recommends that all integrated circuits be handled with appropriate precautions. Failure to observe proper handling and installation procedures can cause damage.

ESD damage can range from subtle performance degradation to complete device failure. Precision integrated circuits may be more susceptible to damage because very small parametric changes could cause the device not to meet its published specifications.

### AVAILABLE OPTIONS<sup>(1)</sup>

| PRODUCT      | V <sub>OUT</sub>  |
|--------------|---|
| TLV701xxyyyz | <b>XX</b> is nominal output voltage (for example, 30 = 3.0 V)<br><b>YYY</b> is Package Designator<br><b>Z</b> is Package Quantity |

- (1) For the most current package and ordering information, see the Package Option Addendum at the end of this document, or visit the device product folder at [www.ti.com](http://www.ti.com).

### ABSOLUTE MAXIMUM RATINGS<sup>(1)</sup>

Over operating free-air temperature range, unless otherwise noted.

|   |   | VALUE              |      | UNIT |
|---|---|--------------------|------|------|
|   |   | MIN                | MAX  |      |
| Voltage <sup>(2)</sup>                        | IN  | -0.3               | 24   | V    |
| Current source                                | OUT   | Internally limited |      |      |
| Temperature                                   | Operating junction, T <sub>J</sub>                          | -40                | +150 | °C   |
|   | Storage, T <sub>stg</sub>                                   | -65                | +150 | °C   |
| Electrostatic Discharge Rating <sup>(3)</sup> | Human body model (HBM)<br>QSS 009-105 (JESD22-A114A)        |                    | 2    | kV   |
|   | Charged device model (CDM)<br>QSS 009-147 (JESD22-C101B.01) |                    | 500  | V    |

- (1) Stresses beyond those listed under *absolute maximum ratings* may cause permanent damage to the device. These are stress ratings only, and functional operation of the device at these or any other conditions beyond those indicated under *recommended operating conditions* is not implied. Exposure to absolute-maximum-rated conditions for extended periods may affect device reliability.
- (2) All voltages are with respect to network ground terminal.
- (3) ESD testing is performed according to the respective JEDEC standard.

### THERMAL INFORMATION

| THERMAL METRIC <sup>(1)</sup> |  | TLV701XX | UNITS |
|-------------------------------|--|----------|-------|
|                               |  | DBV      |       |
|                               |  | 5 PINS   |       |
| θ <sub>JA</sub>               | Junction-to-ambient thermal resistance       | 213.1    | °C/W  |
| θ <sub>JCtop</sub>            | Junction-to-case (top) thermal resistance    | 110.9    |       |
| θ <sub>JB</sub>               | Junction-to-board thermal resistance         | 97.4     |       |
| ψ <sub>JT</sub>               | Junction-to-top characterization parameter   | 22.0     |       |
| ψ <sub>JB</sub>               | Junction-to-board characterization parameter | 78.4     |       |
| θ <sub>JCbot</sub>            | Junction-to-case (bottom) thermal resistance | n/a      |       |

- (1) For more information about traditional and new thermal metrics, see the *IC Package Thermal Metrics* application report, [SPRA953](http://www.ti.com/lit/zip/Spra953).

**ELECTRICAL CHARACTERISTICS: T<sub>A</sub> = +25°C**

All values are at T<sub>A</sub> = +25°C, V<sub>IN</sub> = V<sub>OUT(nom)</sub> + 1 V, I<sub>OUT</sub> = 1 mA, and C<sub>OUT</sub> = 1 μF, unless otherwise noted.

| PARAMETER                             | TEST CONDITIONS                | TLV701xx   |     |     | UNIT |    |
|---------------------------------------|--------------------------------|--|-----|-----|------|----|
|                                       |                                | MIN  | TYP | MAX |      |    |
| V <sub>O</sub>                        | Input voltage range            |  |     | 24  | V    |    |
|                                       | Output voltage range           | 1.2  |     | 5   | V    |    |
| V <sub>OUT</sub>                      | DC output accuracy             | -2   |     | 2   | %    |    |
| ΔV <sub>O</sub> for ΔV <sub>IN</sub>  | Line regulation                | V <sub>OUT(NOM)</sub> + 1 V < V <sub>IN</sub> < 24 V |     | 20  | 50   | mV |
| ΔV <sub>O</sub> for ΔI <sub>OUT</sub> | Load regulation                | 1 mA < I <sub>OUT</sub> < 10 mA                      |     | 6   |      | mV |
|                                       |                                | 1 mA < I <sub>OUT</sub> < 50 mA                      |     | 19  |      | mV |
|                                       |                                | 1 mA < I <sub>OUT</sub> < 100 mA                     |     | 29  | 50   | mV |
| V <sub>DO</sub>                       | Dropout voltage <sup>(1)</sup> | I <sub>OUT</sub> = 10 mA                             |     | 75  |      | mV |
|                                       |                                | I <sub>OUT</sub> = 50 mA                             |     | 400 |      | mV |
| I <sub>CL</sub>                       | Output current limit           | V <sub>OUT</sub> = 0 V                               |     | 160 | 1000 | mA |
| I <sub>GND</sub>                      | Ground pin current             | I <sub>OUT</sub> = 0 mA                              |     | 3.2 | 4.5  | μA |
|                                       |                                | I <sub>OUT</sub> = 100 mA                            |     | 3.4 | 5.5  | μA |
| PSRR                                  | Power-supply rejection ratio   | f = 100 kHz, C <sub>OUT</sub> = 10 μF                |     | 60  |      | dB |

(1) V<sub>IN</sub> = V<sub>OUT(NOM)</sub> - 0.1 V.

**FUNCTIONAL BLOCK DIAGRAM**

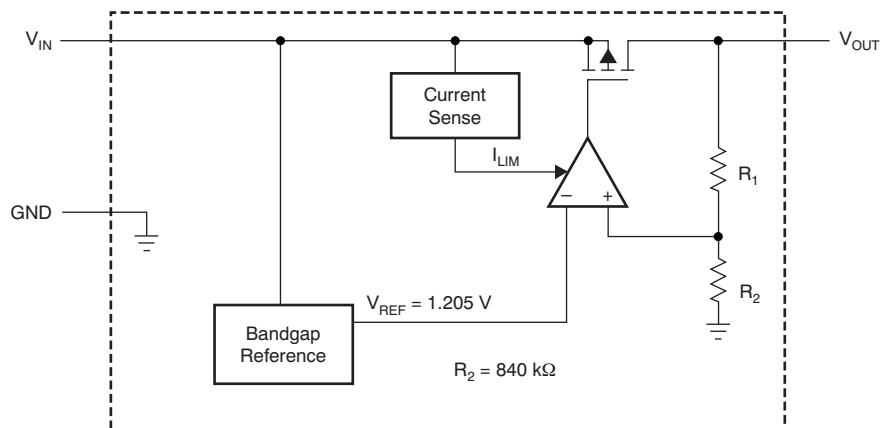

**PRODUCT PREVIEW**

### PIN CONFIGURATIONS

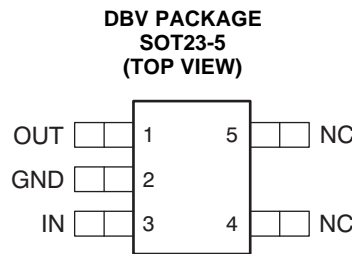

**Table 1. Pin Descriptions**

| TLV701xx |      | DESCRIPTION  |
|----------|------|--|
| NAME     | DBV  |  |
| GND      | 2    | Ground   |
| IN       | 3    | Unregulated input voltage.   |
| OUT      | 1    | Regulated output voltage.<br>Any capacitor 1 $\mu$ F or greater between this pin and ground is needed for stability. |
| NC       | 4, 5 | No connection. This pin can be left open or tied to ground for improved thermal performance.                         |

PRODUCT PREVIEW

TYPICAL CHARACTERISTICS

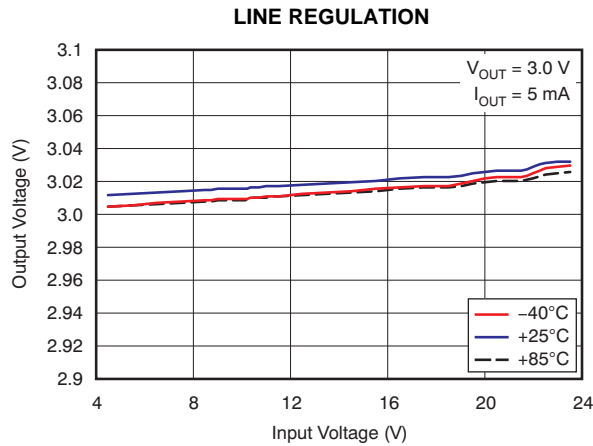

Figure 1.

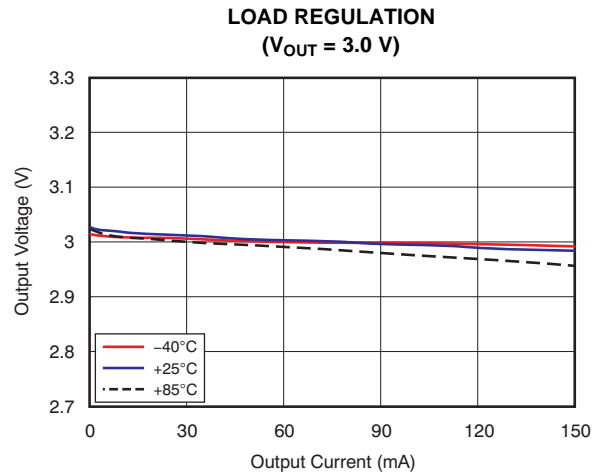

Figure 2.

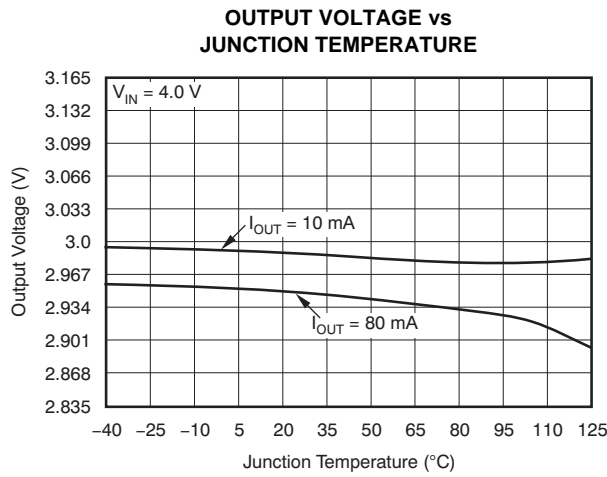

Figure 3.

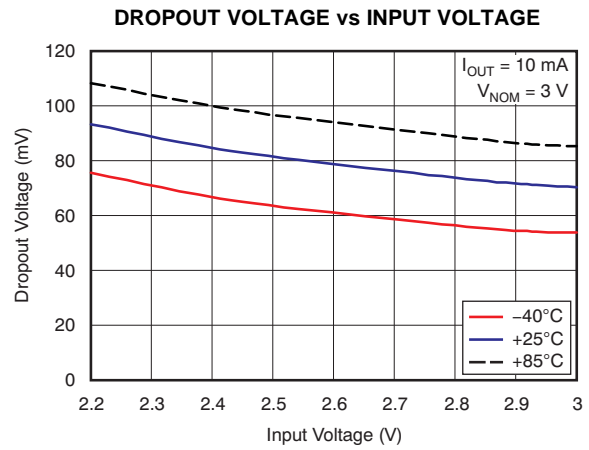

Figure 4.

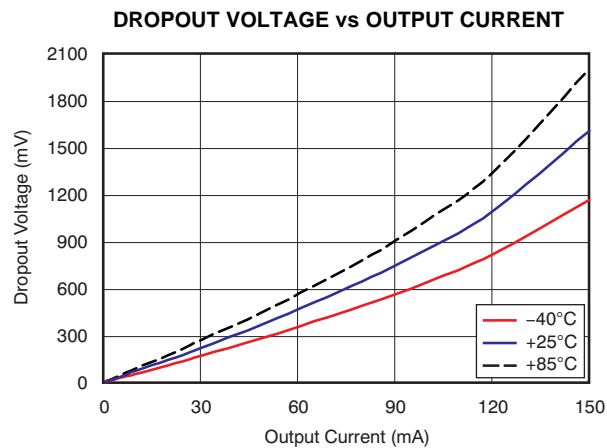

Figure 5.

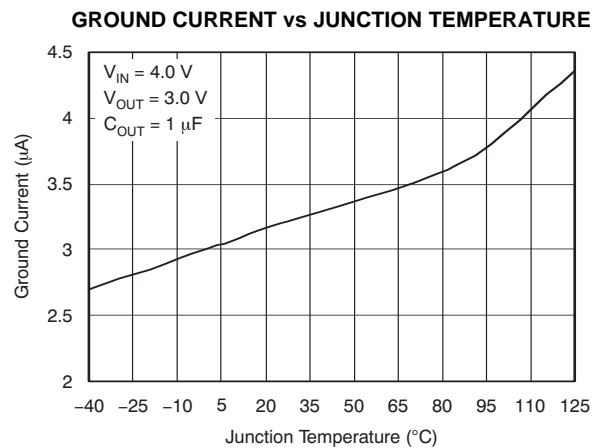

Figure 6.

PRODUCT PREVIEW

**TYPICAL CHARACTERISTICS (continued)**

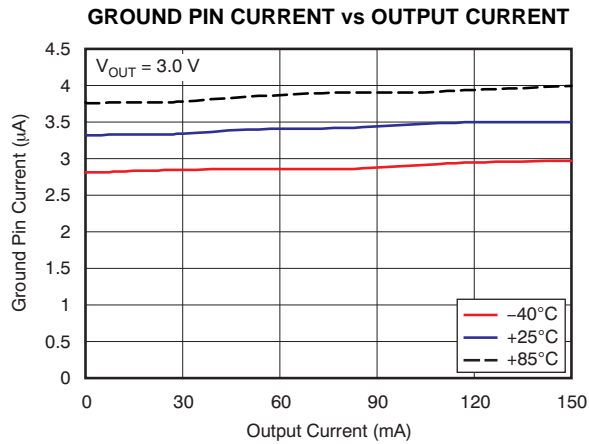

Figure 7.

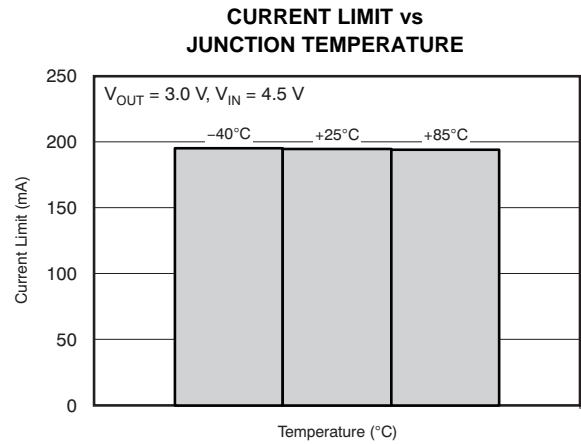

Figure 8.

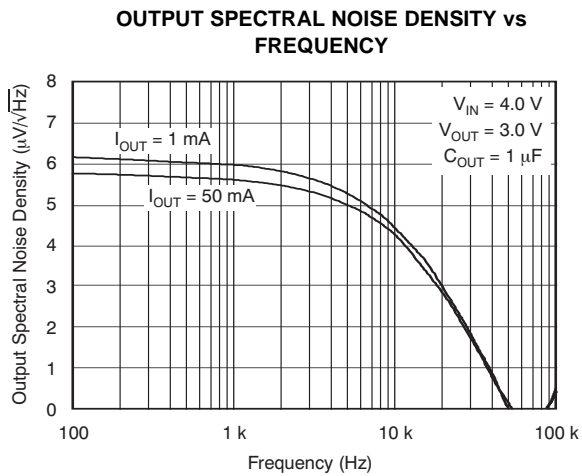

Figure 9.

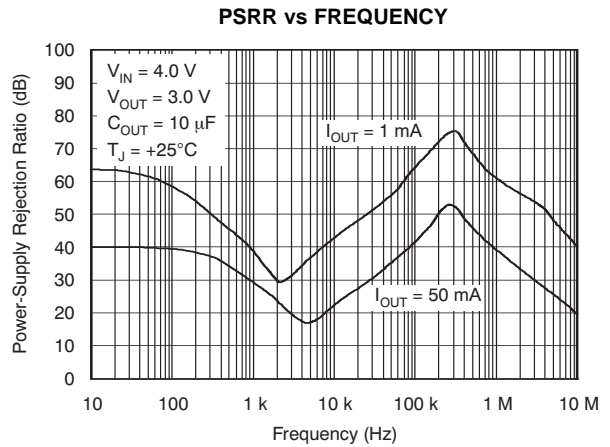

Figure 10.

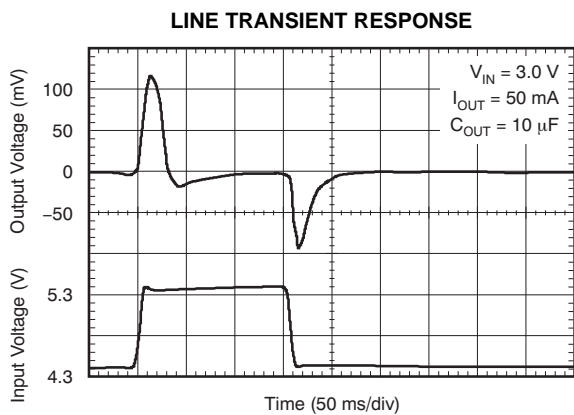

Figure 11.

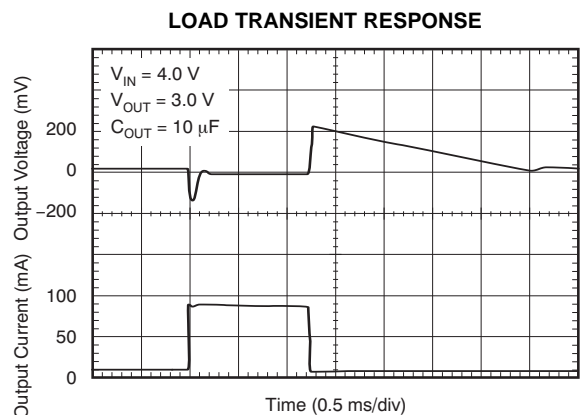

Figure 12.

PRODUCT PREVIEW

## APPLICATION INFORMATION

The TLV701xx series of devices belong to a family of ultralow,  $I_Q$ , low-dropout (LDO) regulators.  $I_Q$  remains fairly constant over the complete output load current and temperature range. The devices are ensured to operate over a temperature range of  $-40^{\circ}\text{C}$  to  $+125^{\circ}\text{C}$ .

### INPUT AND OUTPUT CAPACITOR REQUIREMENTS

The TLV701 requires a 1- $\mu\text{F}$  or larger capacitor connected between OUT and GND for stability. Ceramic or tantalum capacitors can be used. Larger value capacitors result in better transient and noise performance.

Although an input capacitor is not required for stability, when a 0.1- $\mu\text{F}$  or larger capacitor is placed between IN and GND, it counteracts reactive input sources and improves transient and noise performance. Higher value capacitors are necessary if large, fast rise time load transients are anticipated.

### BOARD LAYOUT RECOMMENDATIONS

Input and output capacitors should be placed as close to the device pins as possible. To avoid interference of noise and ripple on the board, it is recommended that the board be designed with separate ground planes for  $V_{\text{IN}}$  and  $V_{\text{OUT}}$ , with the ground plane connected only at the device GND pin. In addition, the ground connection for the output capacitor should be connected directly to the device GND pin.

### POWER DISSIPATION AND JUNCTION TEMPERATURE

To ensure reliable operation, worst-case junction temperature should not exceed  $+125^{\circ}\text{C}$ . This restriction limits the power dissipation the regulator can handle in any given application. To ensure the junction temperature is within acceptable limits, calculate the maximum allowable dissipation,  $P_{\text{D(max)}}$ , and the actual dissipation,  $P_{\text{D}}$ , which must be less than or equal to  $P_{\text{D(max)}}$ .

The maximum power dissipation limit is determined using [Equation 1](#):

$$P_{\text{D(max)}} = \frac{T_{\text{Jmax}} - T_{\text{A}}}{R_{\theta\text{JA}}} \quad (1)$$

where:

$T_{\text{Jmax}}$  is the maximum allowable junction temperature.

$R_{\theta\text{JA}}$  is the thermal resistance junction-to-ambient for the package.

$T_{\text{A}}$  is the ambient temperature.

The regulator dissipation is calculated using [Equation 2](#):

$$P_{\text{D}} = (V_{\text{IN}} - V_{\text{OUT}}) \times I_{\text{OUT}} \quad (2)$$

Power dissipation that results from quiescent current is negligible.

### REGULATOR PROTECTION

The TLV701xx series of LDO regulators use a PMOS-pass transistor that has a built-in back diode that conducts reverse current when the input voltage drops below the output voltage (for example, during power-down). Current is conducted from the output to the input and is not internally limited. If extended reverse voltage operation is anticipated, external limiting might be appropriate.

The TLV701xx features internal current limiting. During normal operation, the TLV701xx limits output current to approximately 250 mA. When current limiting engages, the output voltage scales back linearly until the overcurrent condition ends. Take care not to exceed the rated maximum operating junction temperature of  $+125^{\circ}\text{C}$ . Continuously running the device under conditions where the junction temperature exceeds  $+125^{\circ}\text{C}$  degrades device reliability.

The ability to remove heat from the die is different for each package type, presenting different considerations in the printed circuit board (PCB) layout. The PCB area around the device that is free of other components moves the heat from the device to the ambient air. Using heavier copper increases the effectiveness in removing heat from the device. The addition of plated through-holes to heat-dissipating layers also improves heatsink effectiveness. Power dissipation depends on input voltage and load conditions. Power dissipation ( $P_{\text{D}}$ ) is equal to the product of the output current and the voltage drop across the output pass element, as shown in [Equation 2](#).

## PACKAGING INFORMATION

| Orderable Device | Status<br>(1) | Package Type | Package Drawing | Pins | Package Qty | Eco Plan<br>(2)         | Lead/Ball Finish<br>(6) | MSL Peak Temp<br>(3) | Op Temp (°C) | Device Marking<br>(4/5) | Samples                 |
|------------------|---------------|--------------|-----------------|------|-------------|-------------------------|-------------------------|----------------------|--------------|-------------------------|-------------------------|
| TLV70130DBVR     | ACTIVE        | SOT-23       | DBV             | 5    | 3000        | Green (RoHS & no Sb/Br) | CU NIPDAU               | Level-1-260C-UNLIM   | -40 to 125   | YBVA                    | <a href="#">Samples</a> |
| TLV70130DBVT     | ACTIVE        | SOT-23       | DBV             | 5    | 250         | Green (RoHS & no Sb/Br) | CU NIPDAU               | Level-1-260C-UNLIM   | -40 to 125   | YBVA                    | <a href="#">Samples</a> |
| TLV70133DBVR     | ACTIVE        | SOT-23       | DBV             | 5    | 3000        | Green (RoHS & no Sb/Br) | CU NIPDAU               | Level-1-260C-UNLIM   | -40 to 125   | YBWA                    | <a href="#">Samples</a> |
| TLV70133DBVT     | ACTIVE        | SOT-23       | DBV             | 5    | 250         | Green (RoHS & no Sb/Br) | CU NIPDAU               | Level-1-260C-UNLIM   | -40 to 125   | YBWA                    | <a href="#">Samples</a> |

(1) The marketing status values are defined as follows:

**ACTIVE:** Product device recommended for new designs.

**LIFEBUY:** TI has announced that the device will be discontinued, and a lifetime-buy period is in effect.

**NRND:** Not recommended for new designs. Device is in production to support existing customers, but TI does not recommend using this part in a new design.

**PREVIEW:** Device has been announced but is not in production. Samples may or may not be available.

**OBSELETE:** TI has discontinued the production of the device.

(2) Eco Plan - The planned eco-friendly classification: Pb-Free (RoHS), Pb-Free (RoHS Exempt), or Green (RoHS & no Sb/Br) - please check <http://www.ti.com/productcontent> for the latest availability information and additional product content details.

**TBD:** The Pb-Free/Green conversion plan has not been defined.

**Pb-Free (RoHS):** TI's terms "Lead-Free" or "Pb-Free" mean semiconductor products that are compatible with the current RoHS requirements for all 6 substances, including the requirement that lead not exceed 0.1% by weight in homogeneous materials. Where designed to be soldered at high temperatures, TI Pb-Free products are suitable for use in specified lead-free processes.

**Pb-Free (RoHS Exempt):** This component has a RoHS exemption for either 1) lead-based flip-chip solder bumps used between the die and package, or 2) lead-based die adhesive used between the die and leadframe. The component is otherwise considered Pb-Free (RoHS compatible) as defined above.

**Green (RoHS & no Sb/Br):** TI defines "Green" to mean Pb-Free (RoHS compatible), and free of Bromine (Br) and Antimony (Sb) based flame retardants (Br or Sb do not exceed 0.1% by weight in homogeneous material)

(3) MSL, Peak Temp. - The Moisture Sensitivity Level rating according to the JEDEC industry standard classifications, and peak solder temperature.

(4) There may be additional marking, which relates to the logo, the lot trace code information, or the environmental category on the device.

(5) Multiple Device Markings will be inside parentheses. Only one Device Marking contained in parentheses and separated by a "~" will appear on a device. If a line is indented then it is a continuation of the previous line and the two combined represent the entire Device Marking for that device.

(6) Lead/Ball Finish - Orderable Devices may have multiple material finish options. Finish options are separated by a vertical ruled line. Lead/Ball Finish values may wrap to two lines if the finish value exceeds the maximum column width.

**Important Information and Disclaimer:** The information provided on this page represents TI's knowledge and belief as of the date that it is provided. TI bases its knowledge and belief on information provided by third parties, and makes no representation or warranty as to the accuracy of such information. Efforts are underway to better integrate information from third parties. TI has taken and continues to take reasonable steps to provide representative and accurate information but may not have conducted destructive testing or chemical analysis on incoming materials and chemicals. TI and TI suppliers consider certain information to be proprietary, and thus CAS numbers and other limited information may not be available for release.

In no event shall TI's liability arising out of such information exceed the total purchase price of the TI part(s) at issue in this document sold by TI to Customer on an annual basis.

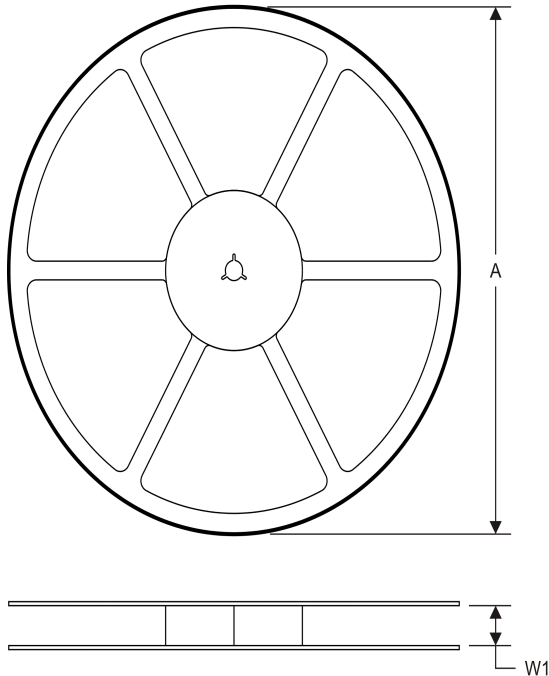
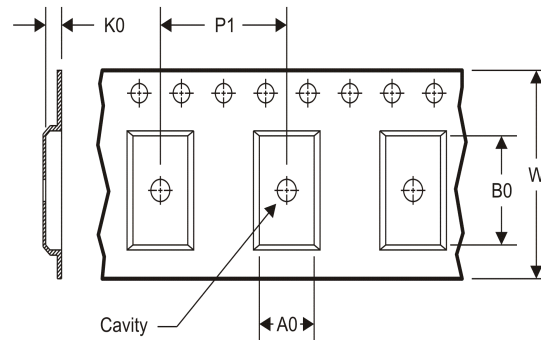
**TAPE AND REEL INFORMATION**
**REEL DIMENSIONS**

**TAPE DIMENSIONS**

|    |   |
|----|---|
| A0 | Dimension designed to accommodate the component width     |
| B0 | Dimension designed to accommodate the component length    |
| K0 | Dimension designed to accommodate the component thickness |
| W  | Overall width of the carrier tape                         |
| P1 | Pitch between successive cavity centers                   |

**TAPE AND REEL INFORMATION**

\*All dimensions are nominal

| Device       | Package Type | Package Drawing | Pins | SPQ  | Reel Diameter (mm) | Reel Width W1 (mm) | A0 (mm) | B0 (mm) | K0 (mm) | P1 (mm) | W (mm) | Pin1 Quadrant |
|--------------|--------------|-----------------|------|------|--------------------|--------------------|---------|---------|---------|---------|--------|---------------|
| TLV70130DBVR | SOT-23       | DBV             | 5    | 3000 | 178.0              | 9.0                | 3.23    | 3.17    | 1.37    | 4.0     | 8.0    | Q3            |
| TLV70130DBVT | SOT-23       | DBV             | 5    | 250  | 178.0              | 9.0                | 3.23    | 3.17    | 1.37    | 4.0     | 8.0    | Q3            |
| TLV70133DBVR | SOT-23       | DBV             | 5    | 3000 | 178.0              | 9.0                | 3.23    | 3.17    | 1.37    | 4.0     | 8.0    | Q3            |
| TLV70133DBVT | SOT-23       | DBV             | 5    | 250  | 178.0              | 9.0                | 3.23    | 3.17    | 1.37    | 4.0     | 8.0    | Q3            |

**TAPE AND REEL BOX DIMENSIONS**

\*All dimensions are nominal

| Device       | Package Type | Package Drawing | Pins | SPQ  | Length (mm) | Width (mm) | Height (mm) |
|--------------|--------------|-----------------|------|------|-------------|------------|-------------|
| TLV70130DBVR | SOT-23       | DBV             | 5    | 3000 | 180.0       | 180.0      | 18.0        |
| TLV70130DBVT | SOT-23       | DBV             | 5    | 250  | 180.0       | 180.0      | 18.0        |
| TLV70133DBVR | SOT-23       | DBV             | 5    | 3000 | 180.0       | 180.0      | 18.0        |
| TLV70133DBVT | SOT-23       | DBV             | 5    | 250  | 180.0       | 180.0      | 18.0        |



# EXAMPLE BOARD LAYOUT

DBV0005A

SOT-23 - 1.45 mm max height

SMALL OUTLINE TRANSISTOR



LAND PATTERN EXAMPLE  
EXPOSED METAL SHOWN  
SCALE:15X

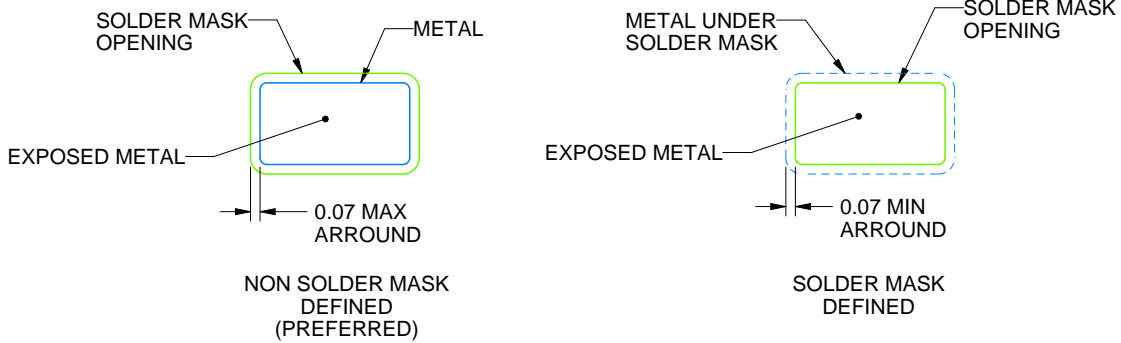

SOLDER MASK DETAILS

4214839/D 11/2018

NOTES: (continued)

5. Publication IPC-7351 may have alternate designs.
6. Solder mask tolerances between and around signal pads can vary based on board fabrication site.



## IMPORTANT NOTICE AND DISCLAIMER

TI PROVIDES TECHNICAL AND RELIABILITY DATA (INCLUDING DATASHEETS), DESIGN RESOURCES (INCLUDING REFERENCE DESIGNS), APPLICATION OR OTHER DESIGN ADVICE, WEB TOOLS, SAFETY INFORMATION, AND OTHER RESOURCES "AS IS" AND WITH ALL FAULTS, AND DISCLAIMS ALL WARRANTIES, EXPRESS AND IMPLIED, INCLUDING WITHOUT LIMITATION ANY IMPLIED WARRANTIES OF MERCHANTABILITY, FITNESS FOR A PARTICULAR PURPOSE OR NON-INFRINGEMENT OF THIRD PARTY INTELLECTUAL PROPERTY RIGHTS.

These resources are intended for skilled developers designing with TI products. You are solely responsible for (1) selecting the appropriate TI products for your application, (2) designing, validating and testing your application, and (3) ensuring your application meets applicable standards, and any other safety, security, or other requirements. These resources are subject to change without notice. TI grants you permission to use these resources only for development of an application that uses the TI products described in the resource. Other reproduction and display of these resources is prohibited. No license is granted to any other TI intellectual property right or to any third party intellectual property right. TI disclaims responsibility for, and you will fully indemnify TI and its representatives against, any claims, damages, costs, losses, and liabilities arising out of your use of these resources.

TI's products are provided subject to TI's Terms of Sale ([www.ti.com/legal/termsofsale.html](http://www.ti.com/legal/termsofsale.html)) or other applicable terms available either on [ti.com](http://ti.com) or provided in conjunction with such TI products. TI's provision of these resources does not expand or otherwise alter TI's applicable warranties or warranty disclaimers for TI products.

Mailing Address: Texas Instruments, Post Office Box 655303, Dallas, Texas 75265  
Copyright © 2019, Texas Instruments Incorporated

## Looking for pricing, stock, or lifecycle information?

Click below to explore more details on WIN SOURCE:

 [View TLV70130DBVR on WIN SOURCE](#)

 [Texas Instruments](#) Information

## Optimize Your Supply Chain with WIN SOURCE Solutions

-  Global Sourcing Solution
-  Obsolete Management
-  Cost Control Management
-  Shortage Management
-  Alternative Solution
-  Excess Inventory Management