



**THE DATASHEET OF
M74VHC1GT66DFT2G**



MC74VHC1GT66

SPST (NO) Normally Open Analog Switch

The MC74VHC1GT66 is a Single Pole Single Throw (SPST) analog switch. It achieves high speed propagation delays and low ON resistances while maintaining low power dissipation. This bilateral switch controls analog and digital voltages that may vary across the full power-supply range (from V_{CC} to GND).

The MC74VHC1GT66 is compatible in function to a single gate of the High Speed CMOS MC74VHCT4066 and the metal-gate CMOS MC14066. The device has been designed so that the ON resistances (R_{ON}) are much lower and more linear over input voltage than R_{ON} of the metal-gate CMOS or High Speed CMOS analog switches.

The ON/OFF Control input is compatible with TTL-type input thresholds allowing the device to be used as a logic-level translator from 3 V CMOS logic to 5 V CMOS logic or from 1.8 V CMOS logic to 3 V CMOS logic while operating at the high-voltage power supply. The input protection circuitry on this device allows overvoltage tolerance on the input, which provides protection when voltages of up to 7 V are applied, regardless of the supply voltage. This allows the MC74VHC1GT66 to be used to interface 5 V circuits to 3 V circuits.

Features

- High Speed: $t_{PD} = 20$ ns (Typ) at $V_{CC} = 5$ V
- Low Power Dissipation: $I_{CC} = 1.0$ μ A (Max) at $T_A = 25^\circ$ C
- Diode Protection Provided on Inputs and Outputs
- Improved Linearity and Lower ON Resistance over Input Voltage
- On/Off Control Input Has OVT
- Chip Complexity: FETs = 11; Equivalent Gates = 3
- Pb-Free Packages are Available



ON Semiconductor®

<http://onsemi.com>

MARKING DIAGRAMS



SC-88A
DF SUFFIX
CASE 419A

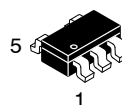
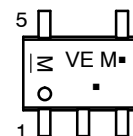

TSOP-5
DT SUFFIX
CASE 483

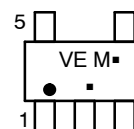

VE = Device Code
M = Date Code*
W = Work Week
▪ = Pb-Free Package

(Note: Microdot may be in either location)

*Date Code orientation and/or position may vary depending upon manufacturing location.

PIN ASSIGNMENT

PIN ASSIGNMENT	
1	IN/OUT X_A
2	OUT/IN Y_A
3	GND
4	ON/OFF CONTROL
5	V_{CC}

FUNCTION TABLE

On/Off Control Input	State of Analog Switch
L	Off
H	On

ORDERING INFORMATION

See detailed ordering and shipping information in the package dimensions section on page 7 of this data sheet.

MC74VHC1GT66

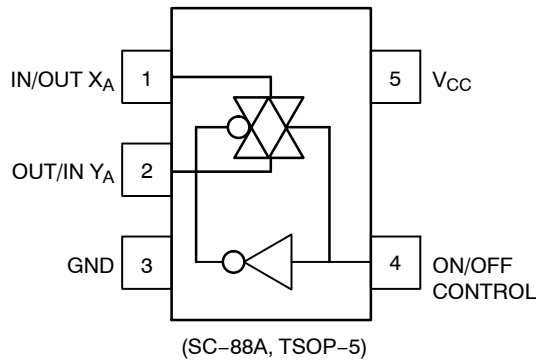

Figure 1. Pinout Diagram

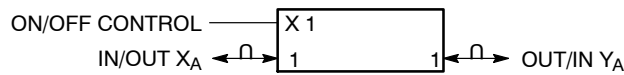

Figure 2. Logic Symbol

MAXIMUM RATINGS

Symbol	Characteristics	Value	Unit
V_{CC}	DC Supply Voltage	-0.5 to +7.0	V
V_{IN}	DC Input Voltage	-0.5 to +7.0	V
V_{IS}	Analog Output Voltage	-0.5 to 7.0	V
I_{IK}	Input Diode Current	-20	mA
I_{CC}	DC Supply Current, V_{CC} and GND	+25	mA
T_{STG}	Storage Temperature Range	-65 to +150	°C
T_L	Lead Temperature, 1 mm from Case for 10 Seconds	260	°C
T_J	Junction Temperature Under Bias	+150	°C
θ_{JA}	Thermal Resistance	SC70-5 (Note 1) SOT23-5 350 230	°C/W
P_D	Power Dissipation in Still Air at 85°C	SC70-5 SOT23-5 150 200	mW
MSL	Moisture Sensitivity	Level 1	
F_R	Flammability Rating	Oxygen Index: 28 to 34 UL 94 V-0 @ 0.125 in	
V_{ESD}	ESD Withstand Voltage	Human Body Model (Note 2) Machine Model (Note 3) Charged Device Model (Note 4) > 2000 > 200 N/A	V
$I_{Latchup}$	Latchup Performance	Above V_{CC} and Below GND at 125°C (Note 5) ± 500	mA

Stresses exceeding Maximum Ratings may damage the device. Maximum Ratings are stress ratings only. Functional operation above the Recommended Operating Conditions is not implied. Extended exposure to stresses above the Recommended Operating Conditions may affect device reliability.

1. Measured with minimum pad spacing on an FR4 board, using 10 mm-by-1 inch, 2-ounce copper trace with no air flow.
2. Tested to EIA/JESD22-A114-A.
3. Tested to EIA/JESD22-A115-A.
4. Tested to JESD22-C101-A.
5. Tested to EIA/JESD78.

MC74VHC1GT66

RECOMMENDED OPERATING CONDITIONS

Symbol	Characteristics	Min	Max	Unit
V _{CC}	DC Supply Voltage	2.0	5.5	V
V _{IN}	Digital Input Voltage	GND	5.5	V
V _{IS}	Analog Input Voltage	GND	V _{CC}	V
T _A	Operating Temperature Range	-55	+125	°C
t _r , t _f	Input Rise and Fall Time	0	100 20	ns/V

$V_{CC} = 3.3\text{ V} \pm 0.3\text{ V}$
 $V_{CC} = 5.0\text{ V} \pm 0.5\text{ V}$

Device Junction Temperature versus Time to 0.1% Bond Failures

Junction Temperature °C	Time, Hours	Time, Years
80	1,032,200	117.8
90	419,300	47.9
100	178,700	20.4
110	79,600	9.4
120	37,000	4.2
130	17,800	2.0
140	8,900	1.0

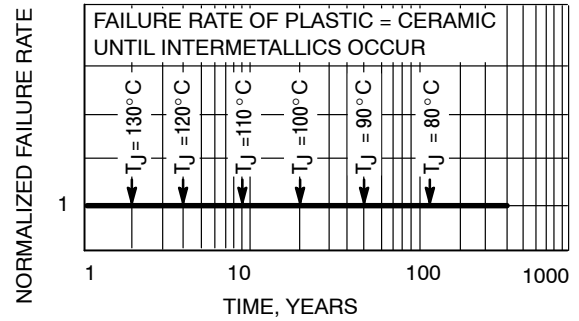

Figure 3. Failure Rate vs. Time Junction Temperature

MC74VHC1GT66

DC ELECTRICAL CHARACTERISTICS

Symbol	Parameter	Test Conditions	V _{CC} (V)	T _A = 25°C		T _A ≤ 85°C		-55°C ≤ T _A ≤ 125°C		Unit
				Min	Max	Min	Max	Min	Max	
V _{IH}	Minimum High-Level Input Voltage ON/OFF Control Input	R _{ON} = Per Spec	3.0 4.5 5.5	1.2 2.0 2.0		1.2 2.0 2.0		1.2 2.0 2.0		V
V _{IL}	Maximum Low-Level Input Voltage ON/OFF Control Input	R _{ON} = Per Spec	3.0 4.5 5.5		0.53 0.8 0.8		0.53 0.8 0.8		0.53 0.8 0.8	V
I _{IN}	Maximum Input Leakage Current ON/OFF Control Input	V _{IN} = V _{CC} or GND	0 to 5.5		±0.1		±1.0		±1.0	μA
I _{CC}	Maximum Quiescent Supply Current	V _{IN} = V _{CC} or GND V _{IO} = 0 V	5.5		1.0		20		40	μA
I _{CCT}	Quiescent Supply Current	ON/OFF Control at 3.4 V	5.5		1.35		1.5		1.65	mA
R _{ON}	Maximum "ON" Resistance	V _{IN} = V _{IH} V _{IS} = V _{CC} or GND I _{IS} ≤ 10 mA (Figure 4)	3.0 4.5 5.5		60 45 40		70 50 45		100 60 55	Ω
I _{OFF}	Maximum Off-Channel Leakage Current	V _{IN} = V _{IL} V _{IS} = V _{CC} or GND Switch Off (Figure 5)	5.5		0.1		0.5		1.0	μA

AC ELECTRICAL CHARACTERISTICS C_{load} = 50 pF, Input t_r/t_f = 3.0 ns

Symbol	Parameter	Test Conditions	V _{CC} (V)	T _A = 25°C			T _A ≤ 85°C		-55°C ≤ T _A ≤ 125°C		Unit
				Min	Typ	Max	Min	Max	Min	Max	
t _{PLH} , t _{PHL}	Maximum Propagation Delay, Input X to Y	Y _A = Open (Figures 7, 14)	2.0 3.0 4.5 5.5		1 0.6 0.6 0.6	5 2 1 1		6 3 1 1		7 4 2 1	ns
t _{PLZ} , t _{PHZ}	Maximum Propagation Delay, ON/OFF Control to Analog Output	R _L = 1000 Ω (Figures 8, 15)	2.0 3.0 4.5 5.5		32 28 24 20	40 35 30 25		45 40 35 30		50 45 40 35	ns
t _{PZL} , t _{PZH}	Maximum Propagation Delay, ON/OFF Control to Analog Output	R _L = 1000 Ω (Figures 8, 15)	2.0 3.0 4.5 5.5		32 28 24 20	40 35 30 25		45 40 35 30		50 45 40 35	ns
C _{IN}	Maximum Input Capacitance	ON/OFF Control Input	0.0		3	10		10		10	pF
		Control Input = GND Analog I/O Feedthrough	5.0		4 4	10 10		10 10		10 10	

C _{PD}	Power Dissipation Capacitance (Note 6)	Typical @ 25°C, V _{CC} = 5.0 V		pF
		18		

6. C_{PD} is defined as the value of the internal equivalent capacitance which is calculated from the operating current consumption without load. Average operating current can be obtained by the equation: I_{CC(OPR)} = C_{PD} • V_{CC} • f_{in} + I_{CC}. C_{PD} is used to determine the no-load dynamic power consumption; P_D = C_{PD} • V_{CC}² • f_{in} + I_{CC} • V_{CC}.

MC74VHC1GT66

ADDITIONAL APPLICATION CHARACTERISTICS (Voltages Referenced to GND Unless Noted)

Symbol	Parameter	Test Conditions	V _{CC}	Limit 25°C	Unit
BW	Maximum On-Channel Bandwidth or Minimum Frequency Response (Figure 10)	f _{in} = 1 MHz Sine Wave Adjust f _{in} voltage to obtain 0 dBm at V _{OS} Increase f _{in} = frequency until dB meter reads -3 dB R _L = 50 Ω	3.0 4.5 5.5	150 175 180	MHz
ISO _{off}	Off-Channel Feedthrough Isolation (Figure 11)	f _{in} = Sine Wave Adjust f _{in} voltage to obtain 0 dBm at V _{IS} f _{in} = 10 kHz, R _L = 600 Ω	3.0 4.5 5.5	-80 -80 -80	dB
NOISE _{feed}	Feedthrough Noise Control to Switch (Figure 12)	V _{in} ≤ 1 MHz Square Wave (t _r = t _f = 2ns) R _L = 600 Ω	3.0 4.5 5.5	45 60 130	mV _{PP}
THD	Total Harmonic Distortion (Figure 13)	f _{in} = 1 kHz, R _L = 10 kΩ THD = THD _{Measured} - THD _{Source} V _{IS} = 3.0 V _{PP} sine wave V _{IS} = 5.0 V _{PP} sine wave	3.3 5.5	0.30 0.15	%

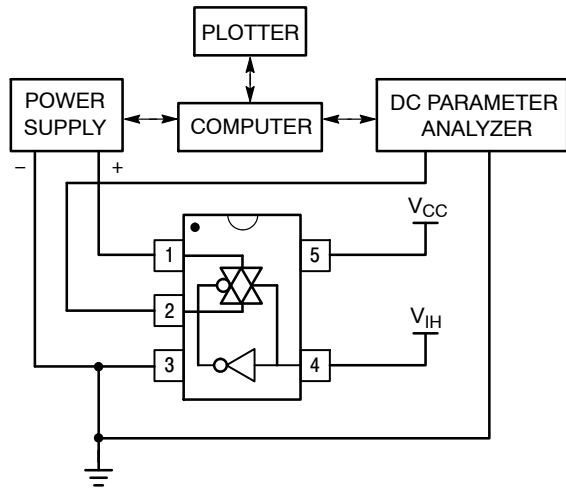

Figure 4. On Resistance Test Set-Up

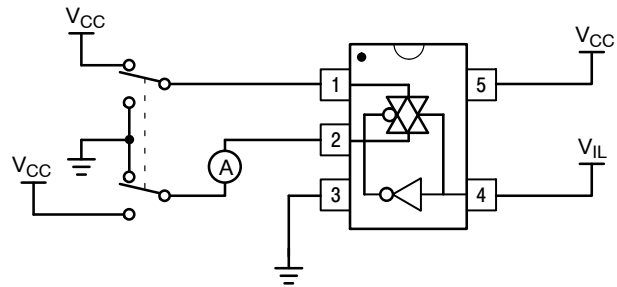

Figure 5. Maximum Off-Channel Leakage Current Test Set-Up

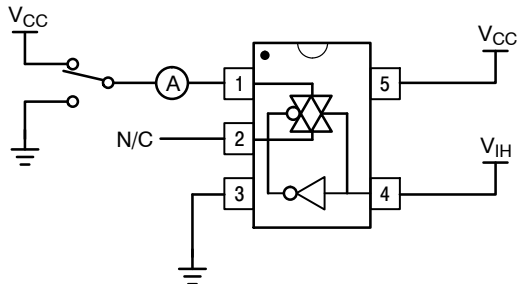

Figure 6. Maximum On-Channel Leakage Current Test Set-Up

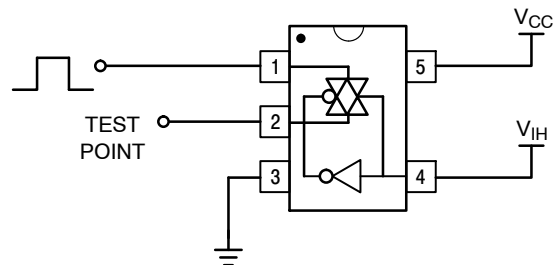
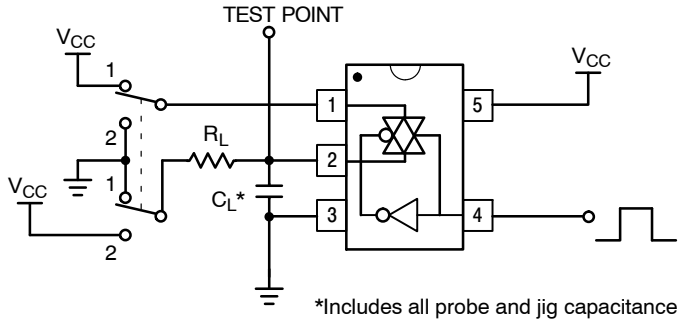

Figure 7. Propagation Delay Test Set-Up

MC74VHC1GT66

Switch to Position 2 when testing t_{PLZ} and t_{PZL}
 Switch to Position 1 when testing t_{PHZ} and t_{PZH}



*Includes all probe and jig capacitance.

Figure 8. Propagation Delay Output Enable/Disable Test Set-Up

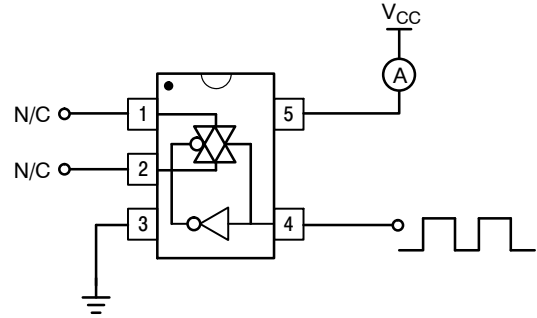
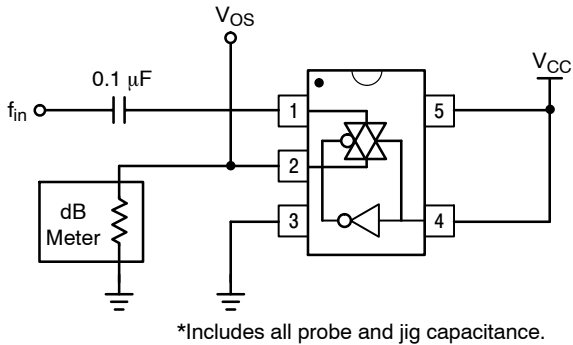
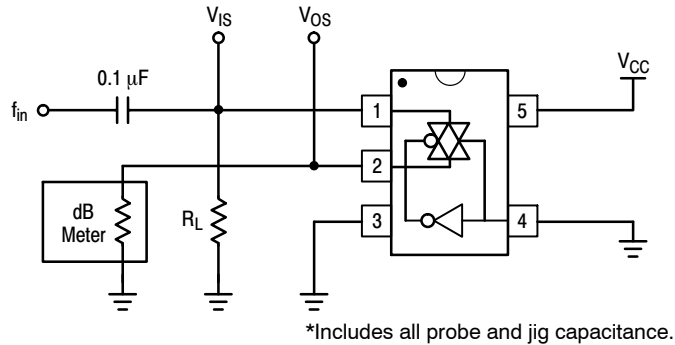

Figure 9. Power Dissipation Capacitance Test Set-Up



*Includes all probe and jig capacitance.

Figure 10. Maximum On-Channel Bandwidth Test Set-Up



*Includes all probe and jig capacitance.

Figure 11. Off-Channel Feedthrough Isolation Test Set-Up

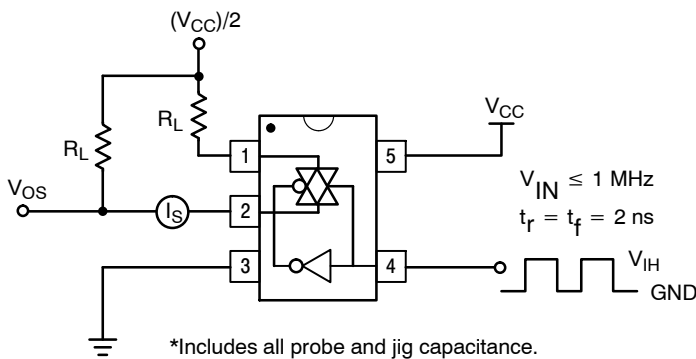

*Includes all probe and jig capacitance.

Figure 12. Feedthrough Noise, ON/OFF Control to Analog Out, Test Set-Up

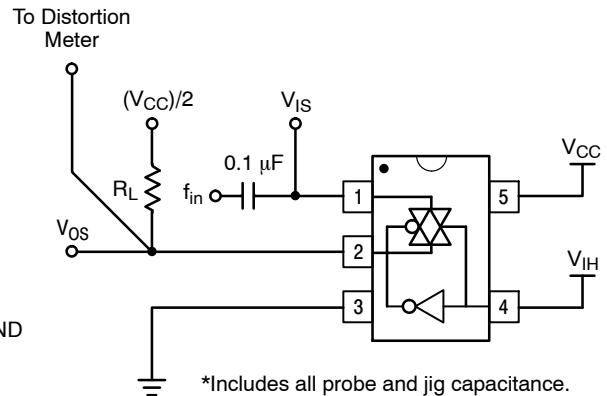

*Includes all probe and jig capacitance.

Figure 13. Total Harmonic Distortion Test Set-Up

MC74VHC1GT66

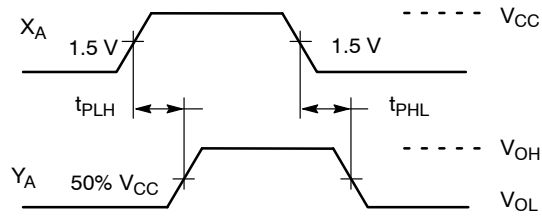

Figure 14. Propagation Delay, Analog In to Analog Out Waveforms

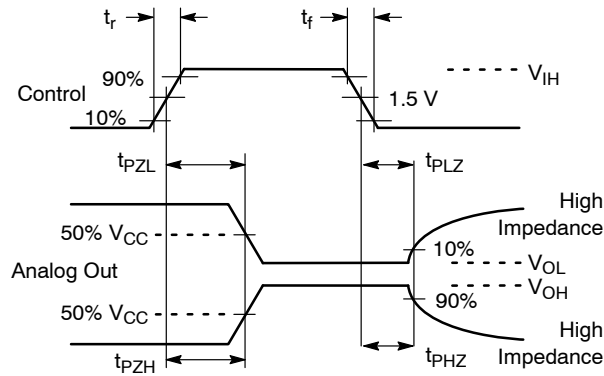

Figure 15. Propagation Delay, ON/OFF Control

ORDERING INFORMATION

Device	Package	Shipping [†]
M74VHC1GT66DFT1G	SC-88A (Pb-Free)	3000 / Tape & Reel
MC74VHC1GT66DFT2	SC-88A	
M74VHC1GT66DFT2G	SC-88A (Pb-Free)	
MC74VHC1GT66DTT1	TSOP-5	
M74VHC1GT66DTT1G	TSOP-5 (Pb-Free)	

[†]For information on tape and reel specifications, including part orientation and tape sizes, please refer to our Tape and Reel Packaging Specifications Brochure, BRD8011/D.

MC74VHC1GT66

PACKAGE DIMENSIONS

SC-88A (SC-70-5/SOT-353)
CASE 419A-02
ISSUE K

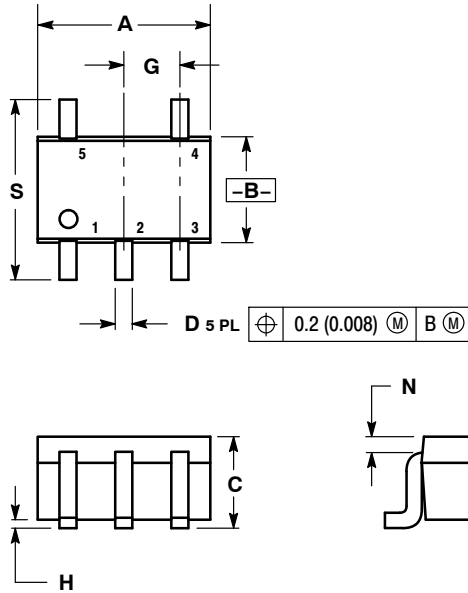

- NOTES:
1. DIMENSIONING AND TOLERANCING PER ANSI Y14.5M, 1982.
 2. CONTROLLING DIMENSION: INCH.
 3. 419A-01 OBSOLETE. NEW STANDARD 419A-02.
 4. DIMENSIONS A AND B DO NOT INCLUDE MOLD FLASH, PROTRUSIONS, OR GATE BURRS.

DIM	INCHES		MILLIMETERS	
	MIN	MAX	MIN	MAX
A	0.071	0.087	1.80	2.20
B	0.045	0.053	1.15	1.35
C	0.031	0.043	0.80	1.10
D	0.004	0.012	0.10	0.30
G	0.026 BSC		0.65 BSC	
H	---	0.004	---	0.10
J	0.004	0.010	0.10	0.25
K	0.004	0.012	0.10	0.30
N	0.008 REF		0.20 REF	
S	0.079	0.087	2.00	2.20

SOLDERING FOOTPRINT*

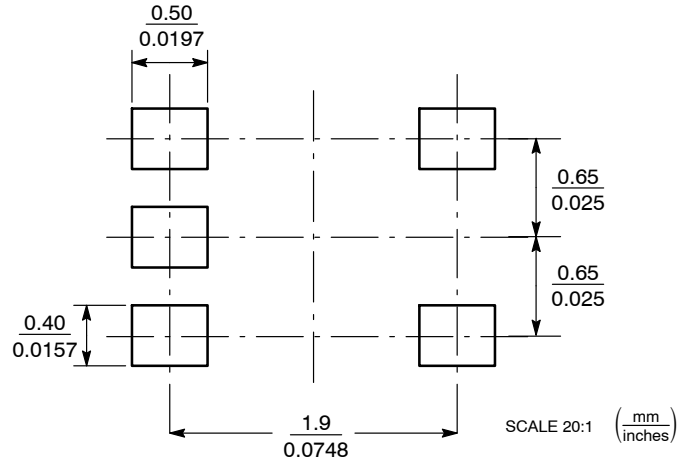

*For additional information on our Pb-Free strategy and soldering details, please download the ON Semiconductor Soldering and Mounting Techniques Reference Manual, SOLDERRM/D.

MC74VHC1GT66

PACKAGE DIMENSIONS

TSOP-5
CASE 483-02
ISSUE H

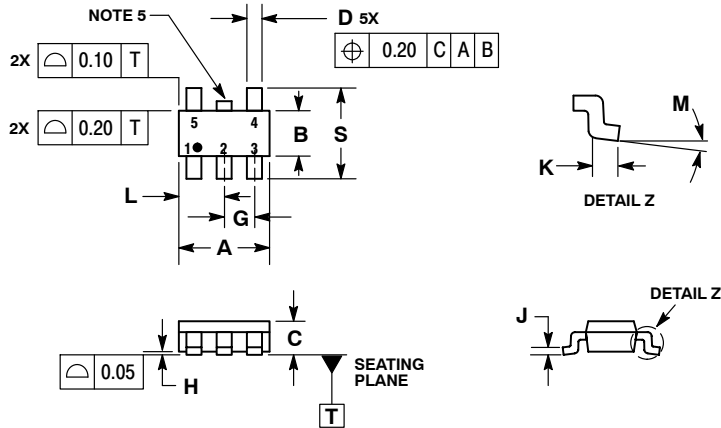

NOTES:

1. DIMENSIONING AND TOLERANCING PER ASME Y14.5M, 1994.
2. CONTROLLING DIMENSION: MILLIMETERS.
3. MAXIMUM LEAD THICKNESS INCLUDES LEAD FINISH THICKNESS. MINIMUM LEAD THICKNESS IS THE MINIMUM THICKNESS OF BASE MATERIAL.
4. DIMENSIONS A AND B DO NOT INCLUDE MOLD FLASH, PROTRUSIONS, OR GATE BURRS.
5. OPTIONAL CONSTRUCTION: AN ADDITIONAL TRIMMED LEAD IS ALLOWED IN THIS LOCATION. TRIMMED LEAD NOT TO EXTEND MORE THAN 0.2 FROM BODY.

DIM	MILLIMETERS	
	MIN	MAX
A	3.00 BSC	
B	1.50 BSC	
C	0.90	1.10
D	0.25	0.50
G	0.95 BSC	
H	0.01	0.10
J	0.10	0.26
K	0.20	0.60
L	1.25	1.55
M	0°	10°
S	2.50	3.00

SOLDERING FOOTPRINT*

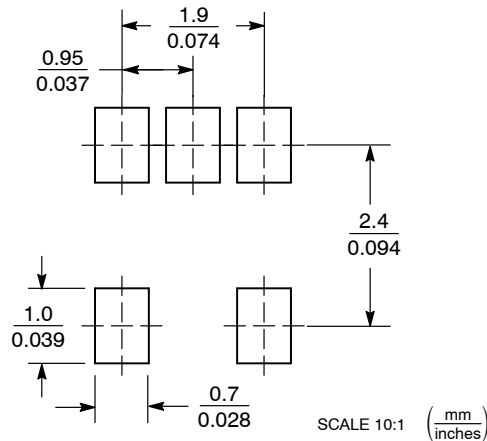

*For additional information on our Pb-Free strategy and soldering details, please download the ON Semiconductor Soldering and Mounting Techniques Reference Manual, SOLDERRM/D.

ON Semiconductor and are registered trademarks of Semiconductor Components Industries, LLC (SCILLC). SCILLC reserves the right to make changes without further notice to any products herein. SCILLC makes no warranty, representation or guarantee regarding the suitability of its products for any particular purpose, nor does SCILLC assume any liability arising out of the application or use of any product or circuit, and specifically disclaims any and all liability, including without limitation special, consequential or incidental damages. "Typical" parameters which may be provided in SCILLC data sheets and/or specifications can and do vary in different applications and actual performance may vary over time. All operating parameters, including "Typicals" must be validated for each customer application by customer's technical experts. SCILLC does not convey any license under its patent rights nor the rights of others. SCILLC products are not designed, intended, or authorized for use as components in systems intended for surgical implant into the body, or other applications intended to support or sustain life, or for any other application in which the failure of the SCILLC product could create a situation where personal injury or death may occur. Should Buyer purchase or use SCILLC products for any such unintended or unauthorized application, Buyer shall indemnify and hold SCILLC and its officers, employees, subsidiaries, affiliates, and distributors harmless against all claims, costs, damages, and expenses, and reasonable attorney fees arising out of, directly or indirectly, any claim of personal injury or death associated with such unintended or unauthorized use, even if such claim alleges that SCILLC was negligent regarding the design or manufacture of the part. SCILLC is an Equal Opportunity/Affirmative Action Employer. This literature is subject to all applicable copyright laws and is not for resale in any manner.

PUBLICATION ORDERING INFORMATION

LITERATURE FULFILLMENT:
Literature Distribution Center for ON Semiconductor
P.O. Box 5163, Denver, Colorado 80217 USA
Phone: 303-675-2175 or 800-344-3860 Toll Free USA/Canada
Fax: 303-675-2176 or 800-344-3867 Toll Free USA/Canada
Email: orderlit@onsemi.com

N. American Technical Support: 800-282-9855 Toll Free
USA/Canada
Europe, Middle East and Africa Technical Support:
Phone: 421 33 790 2910
Japan Customer Focus Center
Phone: 81-3-5773-3850

ON Semiconductor Website: www.onsemi.com
Order Literature: <http://www.onsemi.com/orderlit>
For additional information, please contact your local Sales Representative

Looking for pricing, stock, or lifecycle information?

Click below to explore more details on WIN SOURCE:

- ⊖ [View M74VHC1GT66DFT2G on WIN SOURCE](#)
- ⊖ [ON Semiconductor Information](#)

Optimize Your Supply Chain with WIN SOURCE Solutions

- ✓ Global Sourcing Solution
- ✓ Obsolete Management
- ✓ Cost Control Management
- ✓ Shortage Management
- ✓ Alternative Solution
- ✓ Excess Inventory Management