

High-Voltage Current-Mode PWM Controller

Features

- Input Voltage Range of V_{DD} Regulator
 - HV9110: 10V to 120V
 - HV9112: 9V to 80V
 - HV9113: 10V to 120V
- Maximum Duty, Feedback Accuracy
 - HV9110: 49%, 1%
 - HV9112: 49%, 2%
 - HV9113: 99%, 1%
- Current Mode Control
- <1 mA Supply Current
- >1 MHz clock

Applications

- DC/DC Power Converters

General Description

HV9110/HV9112/HV9113 are Switch-Mode Power Supply (SMPS) controllers suitable for the control of a variety of converter topologies, including the flyback converter and the forward converter.

The V_{DD} regulator supports an input voltage as high as 80V or 120V.

HV9110/HV9112/HV9113 controllers include all essentials for a power converter design, such as a bandgap reference, an error amplifier, a ramp generator, a high-speed PWM comparator, and a gate driver. A shutdown latch provides on/off control.

The HV9110 and HV9113 feature an input voltage range of 10V to 120V, and the HV9112 has an input voltage range of 9V to 80V. The HV9110 and HV9112 have a maximum duty of 49%, while the HV9113 has a maximum duty of 99%.

Package Type

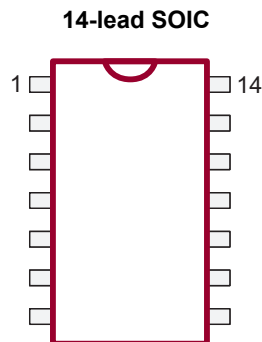

See [Table 3-1](#) for pin information.

HV9110/HV9112/HV9113

Functional Block Diagram

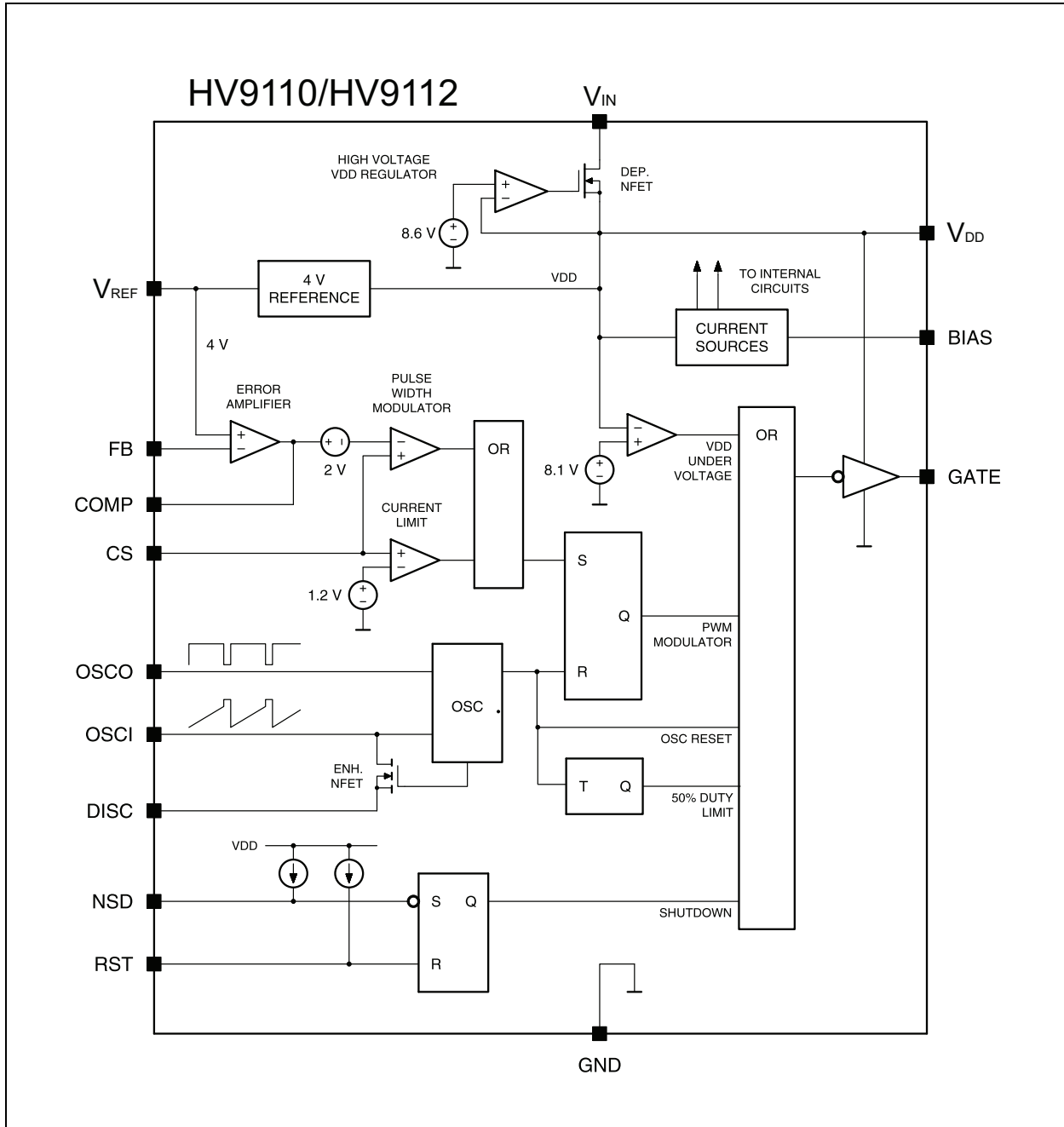

HV9110/HV9112/HV9113

Functional Block Diagram

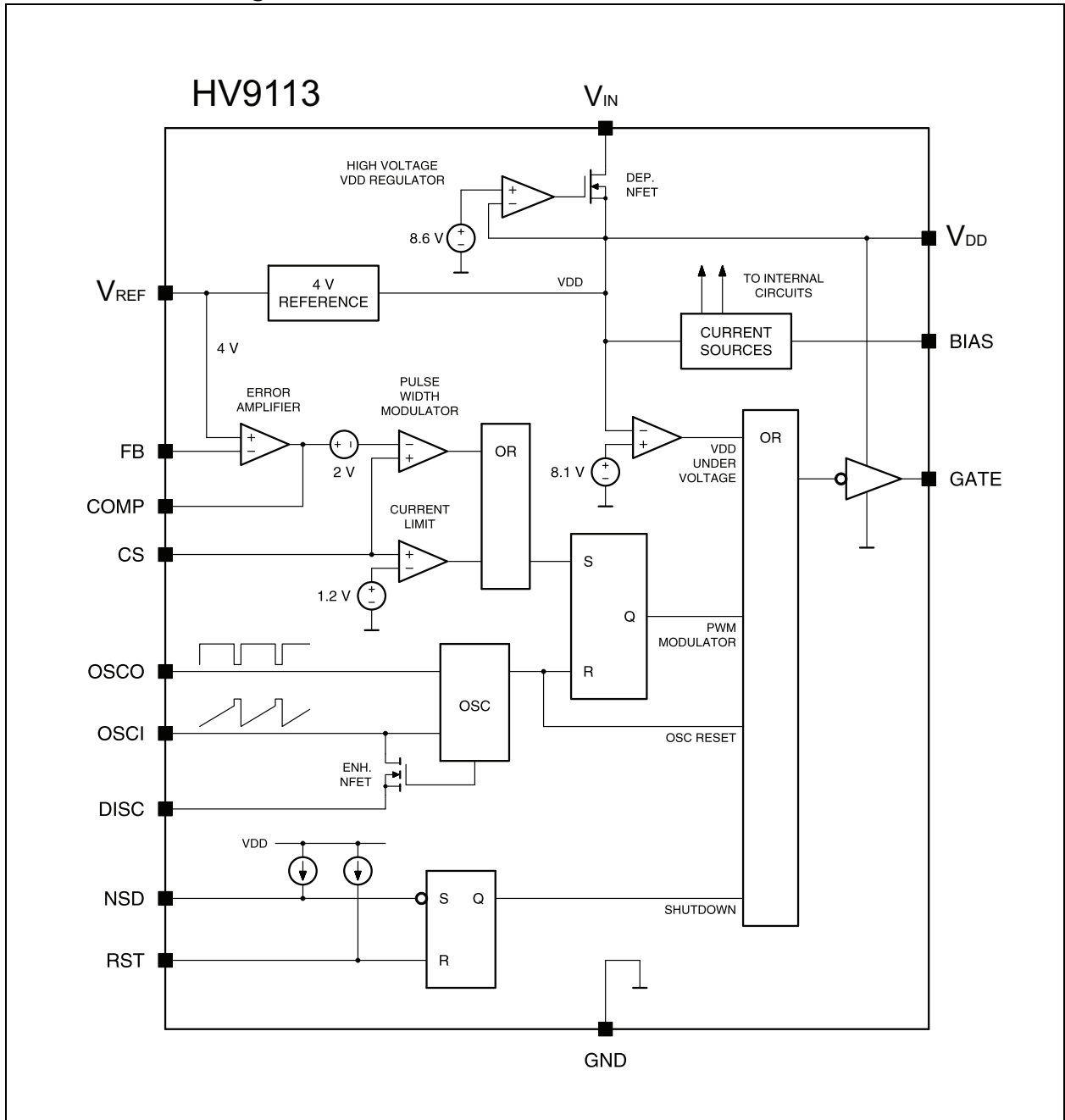

HV9110/HV9112/HV9113

1.0 ELECTRICAL CHARACTERISTICS

ABSOLUTE MAXIMUM RATINGS†

Input Voltage, V_{IN}	
HV9110/HV9113	120V
HV9112	80V
Device Supply Voltage, V_{DD}	15.5V
Logic Input Voltage Range	-0.3V to $V_{DD} + 0.3V$
Linear Input Voltage Range	-0.3V to $V_{DD} + 0.3V$
Storage Temperature Range	-65°C to +150°C
Operating Temperature Range	-55°C to +125°C
Power Dissipation: 14-lead SOIC	750 mW

† **Notice:** Stresses above those listed under “Maximum Ratings” may cause permanent damage to the device. This is a stress rating only and functional operation of the device at those or any other conditions above those indicated in the operational listings of this specification is not implied. Exposure to maximum rating conditions for extended periods may affect device reliability.

ELECTRICAL CHARACTERISTICS

Electrical Specifications: $V_{DD} = 10V$, $V_{IN} = 48V$, $V_{DISC} = 0V$, $R_{BIAS} = 390\text{ k}\Omega$, $R_{OSC} = 330\text{ k}\Omega$, $T_A = 25^\circ\text{C}$ unless otherwise noted.							
Parameters		Sym.	Min.	Typ.	Max.	Units	Conditions
REFERENCE							
Output Voltage	HV9110/13	V_{REF}	3.92	4	4.08	V	$R_L = 10\text{ M}\Omega$
	HV9112		3.88	4	4.12		
	HV9110/13		3.82	4	4.16		$R_L = 10\text{ M}\Omega$, $T_A = -55^\circ\text{C}$ to $+125^\circ\text{C}$
Output Impedance		Z_{OUT}	15	30	45	k Ω	(Note 1)
Short Circuit Current		I_{SHORT}	—	125	250	μA	$V_{REF} = \text{GND}$
Change in V_{REF} with Temperature		ΔV_{REF}	—	0.25	—	mV/ $^\circ\text{C}$	$T_A = -55^\circ\text{C}$ to $+125^\circ\text{C}$ (Note 1)
OSCILLATOR							
Oscillator Frequency		f_{MAX}	1	3	—	MHz	$R_{OSC} = 0\Omega$
Initial Accuracy		f_{OSC}	80	100	120	kHz	$R_{OSC} = 330\text{ k}\Omega$ (Note)
			160	200	240		$R_{OSC} = 150\text{ k}\Omega$ (Note)
V_{DD} Regulation		—	—	—	15	%	$9.5V < V_{DD} < 13.5V$
Temperature Coefficient		—	—	170	—	ppm/ $^\circ\text{C}$	$T_A = -55^\circ\text{C}$ to $+125^\circ\text{C}$ (Note 1)
PWM							
Maximum Duty Cycle	HV9110/HV9112	D_{MAX}	49	49.4	49.6	%	(Note 1)
	HV9113		95	97	99		
Dead Time	HV9113	D_{MIN}	—	225	—	ns	HV9113 only (Note 1)
Minimum Duty Cycle			—	—	0	%	
Pulse Width where Pulse drops out			—	80	125	ns	(Note 1)
CURRENT LIMIT							
Maximum Input Signal		V_{LIM}	1	1.2	1.4	V	$V_{FB} = 0V$
Delay to Output		t_D	—	80	120	ns	$V_{CS} = 1.5V$, $V_{COMP} \leq 2V$ (Note 1)

HV9110/HV9112/HV9113

ELECTRICAL CHARACTERISTICS (CONTINUED)

Electrical Specifications: $V_{DD} = 10V$, $V_{IN} = 48V$, $V_{DISC} = 0V$, $R_{BIAS} = 390\text{ k}\Omega$, $R_{OSC} = 330\text{ k}\Omega$, $T_A = 25^\circ\text{C}$ unless otherwise noted.							
Parameters	Sym.	Min.	Typ.	Max.	Units	Conditions	
ERROR AMPLIFIER							
Feedback Voltage	HV9110/13	V_{FB}	3.96	4	4.04	V	V_{FB} shorted to COMP
	HV9112		3.92	4	4.08		
Input Bias Current	I_{IN}	—	25	500	nA	$V_{FB} = 4V$	
Input Offset Voltage	V_{OS}	Nulled during trim			—		
Open-loop Voltage Gain	A_{VOL}	60	80	—	dB	(Note 1)	
Unity Gain Bandwidth	GB	1	1.3	—	MHz	(Note 1)	
Output Source Current	I_{SOURCE}	-1.4	-2	—	mA	$V_{FB} = 3.4V$	
Output Sink Current	I_{SINK}	0.12	0.15	—	mA	$V_{FB} = 4.5V$	
HIGH-VOLTAGE REGULATOR AND START-UP							
Input Voltage	HV9110/13	V_{IN}	—	—	120	V	$I_{IN} < 10\text{ }\mu\text{A}$; $V_{CC} > 9.4V$
	HV9112		—	—	80		
Input Leakage Current	I_{IN}	—	—	10	μA	$V_{DD} > 9.4V$	
Regulator Turn-off Threshold Voltage	V_{TH}	8	8.7	9.4	V	$I_{IN} = 10\text{ }\mu\text{A}$	
Undervoltage Lockout	V_{LOCK}	7	8.1	8.9	V		
SUPPLY							
Supply Current	I_{DD}	—	0.75	1	mA	$C_L < 75\text{ pF}$	
Quiescent Supply Current	I_Q	—	0.55	—	mA	$V_{NSD} = 0V$	
Nominal Bias Current	I_{BIAS}	—	20	—	μA		
Operating Range	V_{DD}	9	—	13.5	V		
SHUTDOWN LOGIC							
Shutdown Delay	t_{SD}	—	50	100	ns	$C_L = 500\text{ pF}$, $V_{CS} = 0V$ (Note 1)	
NSD Pulse Width	t_{SW}	50	—	—	ns	(Note 1)	
RST Pulse Width	t_{RW}	50	—	—	ns	(Note 1)	
Latching Pulse Width	t_{LW}	25	—	—	ns	V_{NSD} , $V_{RST} = 0V$ (Note 1)	
Input Low Voltage	V_{IL}	—	—	2	V		
Input High Voltage	V_{IH}	7	—	—	V		
Input Current, Input High Voltage	I_{IH}	—	1	5	μA	$V_{IN} = V_{DD}$	
Input Current, Input Low Voltage	I_{IL}	—	-25	-35	μA	$V_{IN} = 0V$	
OUTPUT							
Output High Voltage	HV9110/13	V_{OH}	$V_{DD}-0.25$	—	—	V	$I_{OUT} = 10\text{ mA}$
	HV9112		$V_{DD}-0.3$	—	—		
	HV9110/13		$V_{DD}-0.3$	—	—		
Output Low Voltage	All	V_{OL}	—	—	0.2	V	$I_{OUT} = -10\text{ mA}$
	HV9110/13		—	—	0.3		
Output Resistance	Pull up	R_{OUT}	—	15	25	Ω	$I_{OUT} = \pm 10\text{ mA}$
	Pull down		—	8	20		
	Pull up		—	20	30	Ω	
	Pull down		—	10	30		
Rise Time	t_R	—	30	75	ns	$C_L = 500\text{ pF}$ (Note 1)	
Fall Time	t_F	—	20	75	ns	$C_L = 500\text{ pF}$ (Note 1)	

Note 1: Design guidance only; Not 100% tested in production.
Note 2: Stray capacitance on OSC input pin must be $\leq 5\text{ pF}$.

HV9110/HV9112/HV9113

TEMPERATURE SPECIFICATIONS

Parameters	Sym.	Min.	Typ.	Max.	Units	Conditions
TEMPERATURE RANGES						
Operating Temperature	—	-55	—	125	°C	
Storage Temperature	—	-65	—	150	°C	
PACKAGE THERMAL RESISTANCE						
14-lead SOIC	θ_{ja}	—	83	—	°C/W	

1.1 Truth Table

TRUTH TABLE

SHUTDOWN	RESET	OUTPUT
H	H	Normal operation
H	H → L	Normal operation, no change
L	H	Off, not latched
L	L	Off, latched
L → H	L	Off, latched, no change

2.0 TYPICAL PERFORMANCE CURVES

Note: The graphs and tables provided following this note are a statistical summary based on a limited number of samples and are provided for informational purposes only. The performance characteristics listed herein are not tested or guaranteed. In some graphs or tables, the data presented may be outside the specified operating range (e.g. outside specified power supply range) and therefore outside the warranted range.

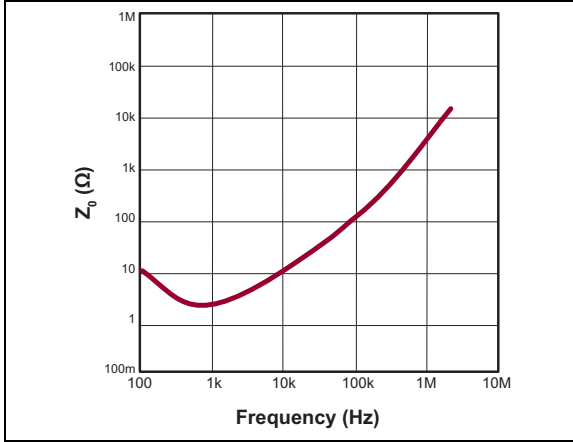

FIGURE 2-1: Error Amplifier Output Impedance (Z_o).

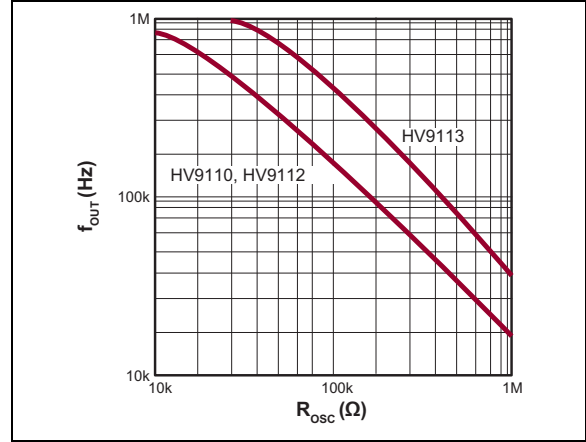

FIGURE 2-4: Output Switching Frequency vs. Oscillator Resistance.

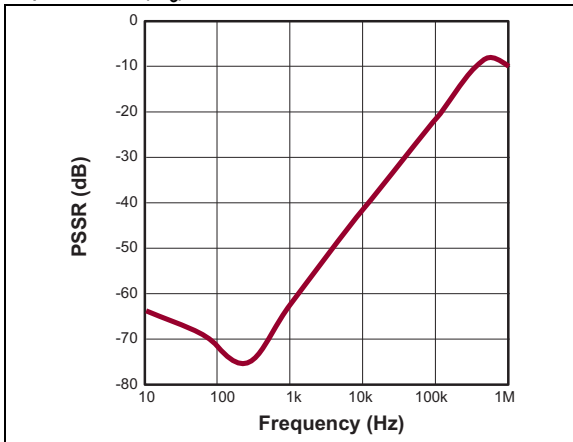

FIGURE 2-2: PSRR - Error Amplifier and Reference.

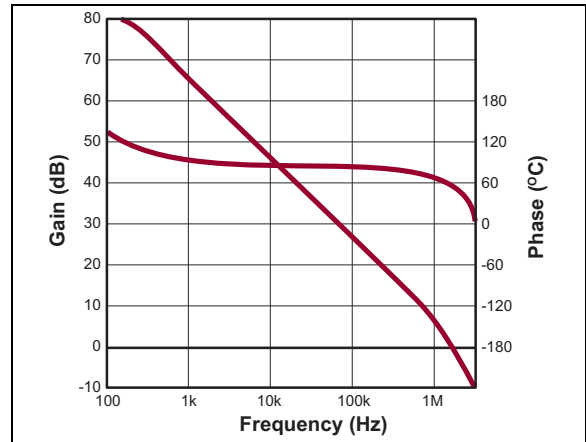

FIGURE 2-5: Error Amplifier Open-loop Gain/Phase.

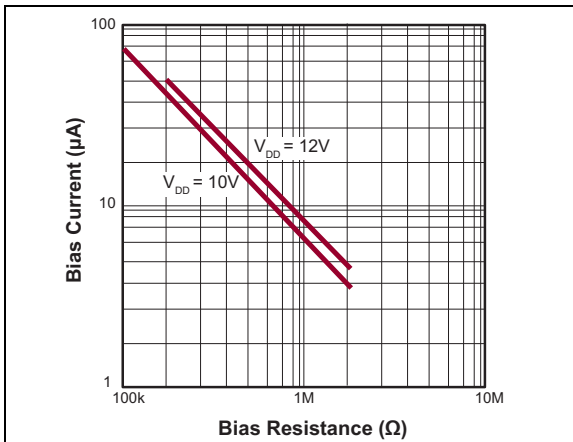

FIGURE 2-3: Bias Current vs. Bias Resistance.

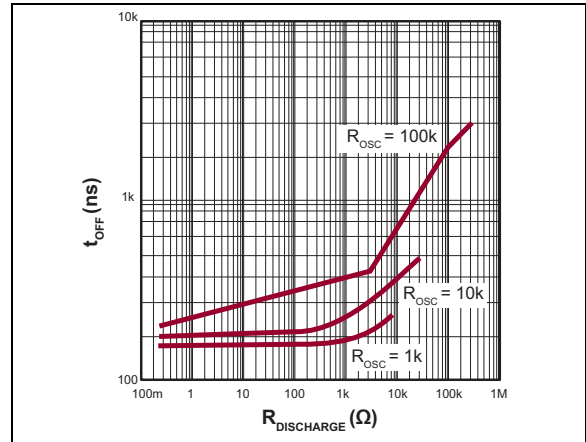

FIGURE 2-6: $R_{DISCHARGE}$ vs. t_{OFF} (HV9113 only).

HV9110/HV9112/HV9113

3.0 PIN DESCRIPTION

Table 3-1 shows the pin description for HV9110/HV9112/HV9113. The locations of the pins are listed in [Features](#).

TABLE 3-1: PIN DESCRIPTION

Pin Number	HV9110/HV9112/HV9113 Pin Name	Description
1	BIAS	Internal bias, current set
2	V _{IN}	High-voltage V _{DD} regulator input
3	CS	Current sense input
4	GATE	Gate drive output
5	GND	Ground
6	V _{DD}	High-voltage V _{DD} regulator output
7	OSCO	Oscillator output
8	OSCI	Oscillator input
9	DISC	Oscillator discharge, current set
10	V _{REF}	4V reference output Reference voltage level can be overridden by an externally applied voltage source.
11	NSD	Active low input to set shutdown latch
12	RST	Active high input to reset shutdown latch
13	COMP	Error amplifier output
14	FB	Feedback voltage input

4.0 TEST CIRCUITS

The test circuits for characterizing error amplifier output impedance, Z_{OUT} , and error amplifier, power supply rejection ratio, PSRR, are shown in Figure 4-1 and Figure 4-2.

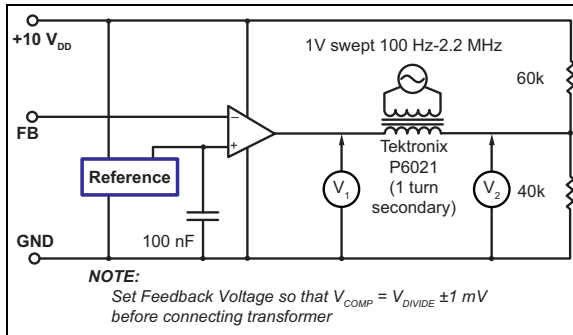

FIGURE 4-1: Error Amp Z_{OUT}

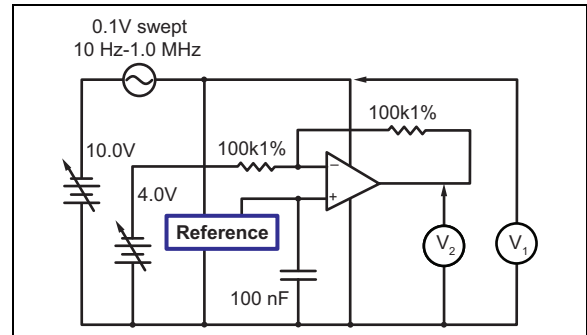

FIGURE 4-2: PSRR.

HV9110/HV9112/HV9113

5.0 DETAILED DESCRIPTION

5.1 High-Voltage Regulator

The high-voltage regulator included in HV9110/HV9112/HV9113 consists of a high-voltage N-channel Depletion-mode DMOS transistor driven by an error amplifier, providing a current path between the V_{IN} terminal and the V_{DD} terminal. The maximum current, about 20 mA, occurs when $V_{DD} = 0$, with current reducing as V_{DD} rises. This path shuts off when V_{DD} rises to somewhere between 8V and 9.4V. So, if V_{DD} is held at 10V or 12V by an external source, no current other than leakage is drawn through the high voltage transistor. This minimizes dissipation within the high-voltage regulator.

Use an external capacitor between V_{DD} and GND. This capacitor should have good high-frequency characteristics. Ceramic caps work well.

The device uses a compound resistor divider to monitor V_{DD} for both the undervoltage lockout circuit and the shutoff circuit of the high-voltage FET. Setting the undervoltage sense point about 0.6V lower on the string than the FET shutoff point guarantees that the undervoltage lockout releases before the FET shuts off.

5.2 Bias Circuit

HV9110/HV9112/HV9113 require an external bias resistor, connected between the Bias pin and GND, to set currents in a series of current mirrors used by the analog sections of the chip. The nominal external bias current requirement is 15 μ A to 20 μ A, which can be set by a 390 k Ω to 510 k Ω resistor if $V_{DD} = 10$ V, or a 510 k Ω to 680 k Ω resistor if $V_{DD} = 12$ V. A precision resistor is not required, $\pm 5\%$ meets device requirements.

5.3 Clock Oscillator

The clock oscillator of the HV9110/HV9112/HV9113 consists of a ring of CMOS inverters, timing capacitors, and a capacitor-discharge FET. A single external resistor between the OSCI and OSCO sets the oscillator frequency. (See [Figure 2-4](#).)

The HV9110 and HV9112 include a frequency-dividing flip-flop that allows the part to operate with a 50% duty limit. Accordingly, the effective switching frequency of the power converter is half the oscillator frequency. (See [Figure 2-4](#).)

An internal discharge FET resets the oscillator ramp at the end of the oscillator cycle. The discharge FET is externally connected to GND, by way of a resistor. The resistor programs the oscillator dead time at the end of the oscillator period.

The oscillator turns off during shutdown to reduce supply current by about 150 μ A.

5.4 Reference

The reference of the HV9110/HV9112/HV9113 consists of a band-gap reference, followed by a buffer amplifier, which scales the voltage up to 4V. The scaling resistors of the buffer amplifier are trimmed during manufacture so that the output of the error amplifier, when connected in a gain of -1 configuration, is as close to 4V as possible. This nulls out the input offset of the error amplifier. As a consequence, even though the observed reference voltage of a specific part may not be exactly 4V, the feedback voltage required for proper regulation will be 4V.

An approximately 50 k Ω resistor is located internally between the output of the reference buffer amplifier and the circuitry it feeds—reference output pin and non-inverting input to the error amplifier. This allows overriding the internal reference with a low impedance voltage source ≤ 6 V. Using an external reference reinstates the input offset voltage of the error amplifier. Overriding the reference should seldom be necessary.

The reference of the HV9110/HV9112/HV9113 is a high-impedance node, and usually there will be significant electrical noise nearby. Therefore, a bypass capacitor between the reference pin and GND is strongly recommended. The reference buffer amplifier is compensated to be stable with a capacitive load of 0.01 μ F to 0.1 μ F.

5.5 Error Amplifier

The error amplifier on HV9110/HV9112/HV9113 is a low-power, differential-input, operational amplifier. A PMOS input stage is used, so the common mode range includes ground and the input impedance is high.

5.6 Current Sense Comparators

The HV9110/HV9112/HV9113 use a dual-comparator system with independent comparators for modulation and current limiting. This provides the designer greater latitude in compensation design, as there are no clamps, except ESD protection, on the compensation pin.

5.7 Remote Shutdown

The NSD and RST pins control the shutdown latch. These pins have internal current-source pull-ups so they can be driven from open drain logic. When not used they should be left open or connected to V_{DD} .

5.8 Output Buffer

The output buffer of HV9110/HV9112/HV9113 is of standard CMOS construction P-channel pull-up and N-channel pull-down. Thus, the body-drain diodes of the output stage can be used for spike clipping. External Schottky diode clamping of the output is not required.

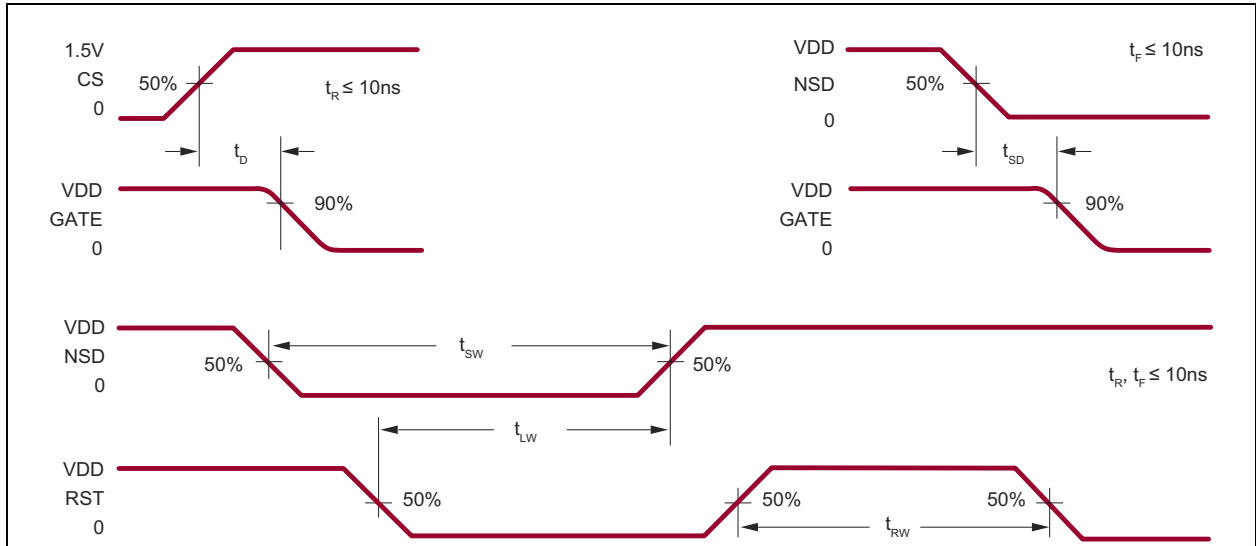
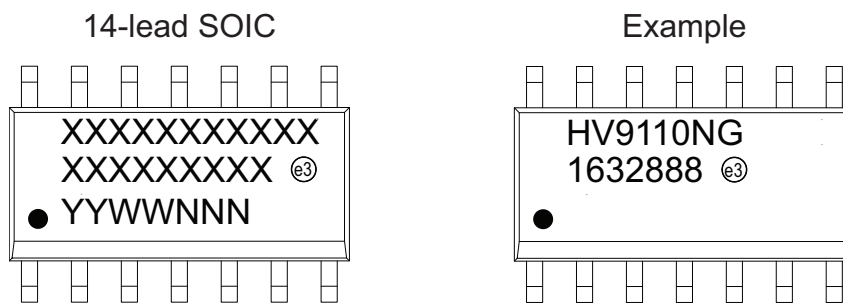

FIGURE 5-1: Shutdown Timing Waveforms.

HV9110/HV9112/HV9113

6.0 PACKAGING INFORMATION

6.1 Package Marking Information



Legend:	XX...X	Product Code or Customer-specific information
	Y	Year code (last digit of calendar year)
	YY	Year code (last 2 digits of calendar year)
	WW	Week code (week of January 1 is week '01')
	NNN	Alphanumeric traceability code
	(e3)	Pb-free JEDEC® designator for Matte Tin (Sn)
	*	This package is Pb-free. The Pb-free JEDEC designator (e3) can be found on the outer packaging for this package.

Note: In the event the full Microchip part number cannot be marked on one line, it will be carried over to the next line, thus limiting the number of available characters for product code or customer-specific information. Package may or not include the corporate logo.

14-Lead SOIC (Narrow Body) Package Outline (NG) 8.65x3.90mm body, 1.75mm height (max), 1.27mm pitch

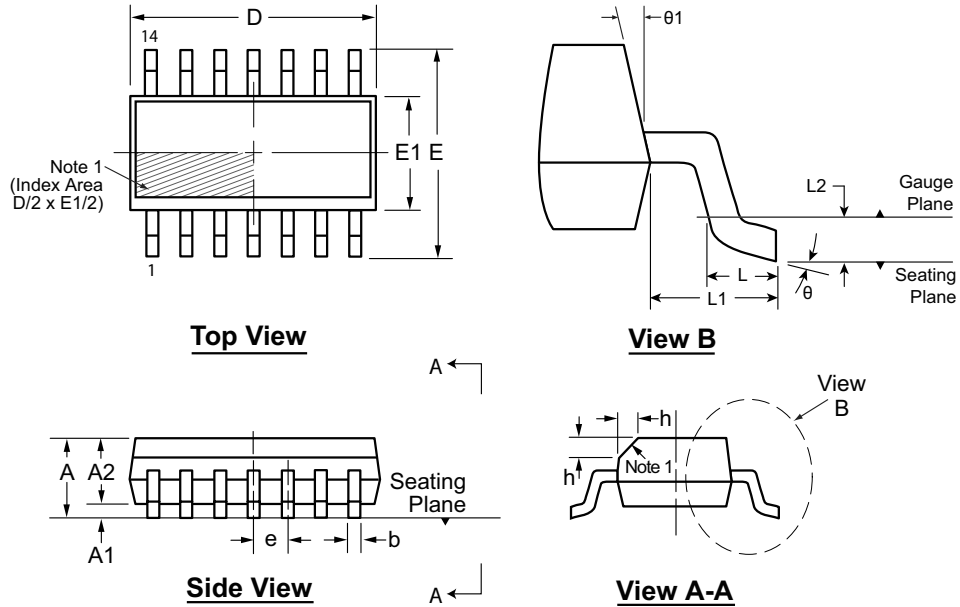

Note: For the most current package drawings, see the Microchip Packaging Specification at www.microchip.com/packaging.

Note:

1. This chamfer feature is optional. If it is not present, then a Pin 1 identifier must be located in the index area indicated. The Pin 1 identifier can be: a molded mark/identifier; an embedded metal marker; or a printed indicator.

Symbol	A	A1	A2	b	D	E	E1	e	h	L	L1	L2	θ	$\theta 1$		
Dimension (mm)	MIN	1.35*	0.10	1.25	0.31	8.55*	5.80*	3.80*	1.27 BSC	0.25	0.40	1.04 REF	0.25	8°	5°	
	NOM	-	-	-	-	8.65	6.00	3.90		-	-		0.25		BSC	-
	MAX	1.75	0.25	1.65*	0.51	8.75*	6.20*	4.00*		0.50	1.27		-		-	15°

JEDEC Registration MS-012, Variation AB, Issue E, Sept. 2005.

* This dimension is not specified in the JEDEC drawing.

Drawings are not to scale.

HV9110/HV9112/HV9113

NOTES:

APPENDIX A: REVISION HISTORY

Revision A (June 2016)

- Merged Supertex Doc #s DSFP-HV9110, DSFP-HV9112 and DSFP-DSFP-HV9113 to Microchip DS20005505A.
- Revised [Electrical Characteristics](#) to accommodate the merged products.
- Updated pin names to reflect new naming convention.
- Significant text changes to [Detailed Description](#).
- Minor text changes throughout.

HV9110/HV9112/HV9113

PRODUCT IDENTIFICATION SYSTEM

To order or obtain information, e.g., on pricing or delivery, refer to the factory or the listed sales office.

<u>PART NO.</u>	<u>XX</u>	-	<u>X</u>	-	<u>X</u>
Device	Package Options		Environmental		Media Type
Device:	HV9110 =	=	High-voltage Current-mode PWM Controller, 10V to 120V Input Voltage Range, 49% Duty Cycle		
	HV9112 =	=	High-voltage Current-mode PWM Controller, 9V to 80V Input Voltage Range, 49% Duty Cycle		
	HV9113 =	=	High-voltage Current-mode PWM Controller, 10V to 120V Input Voltage Range, 99% Duty Cycle		
Package:	NG	=	14-lead SOIC		
Environmental	G	=	Lead (Pb)-free/RoHS-compliant Package		
Media Type:	(blank)	=	53/Tube for an NG package		

Examples:

a) HV9110NG-G: High-voltage Current-mode PWM Controller 10V to 120V Input Voltage Range, 49% Duty Cycle, 14-lead SOIC Package, 53/Tube

b) HV9112NG-G: High-voltage Current-mode PWM Controller, 9V to 80V Input Voltage Range, 49% Duty Cycle, 14-lead SOIC Package, 53/Tube

c) HV9113NG-G: High-voltage Current-mode PWM Controller, 10V to 120V Input Voltage Range, 99% Duty Cycle, 14-lead SOIC Package, 53/Tube

Note the following details of the code protection feature on Microchip devices:

- Microchip products meet the specification contained in their particular Microchip Data Sheet.
- Microchip believes that its family of products is one of the most secure families of its kind on the market today, when used in the intended manner and under normal conditions.
- There are dishonest and possibly illegal methods used to breach the code protection feature. All of these methods, to our knowledge, require using the Microchip products in a manner outside the operating specifications contained in Microchip's Data Sheets. Most likely, the person doing so is engaged in theft of intellectual property.
- Microchip is willing to work with the customer who is concerned about the integrity of their code.
- Neither Microchip nor any other semiconductor manufacturer can guarantee the security of their code. Code protection does not mean that we are guaranteeing the product as “unbreakable.”

Code protection is constantly evolving. We at Microchip are committed to continuously improving the code protection features of our products. Attempts to break Microchip's code protection feature may be a violation of the Digital Millennium Copyright Act. If such acts allow unauthorized access to your software or other copyrighted work, you may have a right to sue for relief under that Act.

DS20005505A Information contained in this publication regarding device applications and the like is provided only for your convenience and may be superseded by updates. It is your responsibility to ensure that your application meets with your specifications. MICROCHIP MAKES NO REPRESENTATIONS OR WARRANTIES OF ANY KIND WHETHER EXPRESS OR IMPLIED, WRITTEN OR ORAL, STATUTORY OR OTHERWISE, RELATED TO THE INFORMATION, INCLUDING BUT NOT LIMITED TO ITS CONDITION, QUALITY, PERFORMANCE, MERCHANTABILITY OR FITNESS FOR PURPOSE. Microchip disclaims all liability arising from this information and its use. Use of Microchip devices in life support and/or safety applications is entirely at the buyer's risk, and the buyer agrees to defend, indemnify and hold harmless Microchip from any and all damages, claims, suits, or expenses resulting from such use. No licenses are conveyed, implicitly or otherwise, under any Microchip intellectual property rights unless otherwise stated.

Microchip received ISO/TS-16949:2009 certification for its worldwide headquarters, design and wafer fabrication facilities in Chandler and Tempe, Arizona; Gresham, Oregon and design centers in California and India. The Company's quality system processes and procedures are for its PIC® MCUs and dsPIC® DSCs, KEELOQ® code hopping devices, Serial EEPROMs, microperipherals, nonvolatile memory and analog products. In addition, Microchip's quality system for the design and manufacture of development systems is ISO 9001:2000 certified.

**QUALITY MANAGEMENT SYSTEM
CERTIFIED BY DNV
= ISO/TS 16949 =**

Trademarks

The Microchip name and logo, the Microchip logo, AnyRate, dsPIC, FlashFlex, flexPWR, Heldo, JukeBlox, KEELOQ, KEELOQ logo, Klear, LANCheck, LINK MD, MediaLB, MOST, MOST logo, MPLAB, OptoLyzer, PIC, PICSTART, PIC32 logo, RightTouch, SpyNIC, SST, SST Logo, SuperFlash and UNI/O are registered trademarks of Microchip Technology Incorporated in the U.S.A. and other countries.

ClockWorks, The Embedded Control Solutions Company, ETHERSYNCH, Hyper Speed Control, HyperLight Load, IntellIMOS, mTouch, Precision Edge, and QUIET-WIRE are registered trademarks of Microchip Technology Incorporated in the U.S.A.

Analog-for-the-Digital Age, Any Capacitor, AnyIn, AnyOut, BodyCom, chipKIT, chipKIT logo, CodeGuard, dsPICDEM, dsPICDEM.net, Dynamic Average Matching, DAM, ECAN, EtherGREEN, In-Circuit Serial Programming, ICSP, Inter-Chip Connectivity, JitterBlocker, KlearNet, KlearNet logo, MiWi, motorBench, MPASM, MPF, MPLAB Certified logo, MPLIB, MPLINK, MultiTRAK, NetDetach, Omniscient Code Generation, PICDEM, PICDEM.net, PICkit, PICtail, PureSilicon, RightTouch logo, REAL ICE, Ripple Blocker, Serial Quad I/O, SQL, SuperSwitcher, SuperSwitcher II, Total Endurance, TSHARC, USBCheck, VariSense, ViewSpan, WiperLock, Wireless DNA, and ZENA are trademarks of Microchip Technology Incorporated in the U.S.A. and other countries.

SQTP is a service mark of Microchip Technology Incorporated in the U.S.A.

Silicon Storage Technology is a registered trademark of Microchip Technology Inc. in other countries.

GestIC is a registered trademarks of Microchip Technology Germany II GmbH & Co. KG, a subsidiary of Microchip Technology Inc., in other countries.

All other trademarks mentioned herein are property of their respective companies.

© 2016, Microchip Technology Incorporated, Printed in the U.S.A., All Rights Reserved.

ISBN: 978-1-5224-0736-2



MICROCHIP

Worldwide Sales and Service

AMERICAS

Corporate Office

2355 West Chandler Blvd.
Chandler, AZ 85224-6199

Tel: 480-792-7200

Fax: 480-792-7277

Technical Support:

[http://www.microchip.com/
support](http://www.microchip.com/support)

Web Address:

www.microchip.com

Atlanta

Duluth, GA

Tel: 678-957-9614

Fax: 678-957-1455

Austin, TX

Tel: 512-257-3370

Boston

Westborough, MA

Tel: 774-760-0087

Fax: 774-760-0088

Chicago

Itasca, IL

Tel: 630-285-0071

Fax: 630-285-0075

Cleveland

Independence, OH

Tel: 216-447-0464

Fax: 216-447-0643

Dallas

Addison, TX

Tel: 972-818-7423

Fax: 972-818-2924

Detroit

Novi, MI

Tel: 248-848-4000

Houston, TX

Tel: 281-894-5983

Indianapolis

Noblesville, IN

Tel: 317-773-8323

Fax: 317-773-5453

Los Angeles

Mission Viejo, CA

Tel: 949-462-9523

Fax: 949-462-9608

New York, NY

Tel: 631-435-6000

San Jose, CA

Tel: 408-735-9110

Canada - Toronto

Tel: 905-695-1980

Fax: 905-695-2078

ASIA/PACIFIC

Asia Pacific Office

Suites 3707-14, 37th Floor
Tower 6, The Gateway
Harbour City, Kowloon

Hong Kong

Tel: 852-2943-5100

Fax: 852-2401-3431

Australia - Sydney

Tel: 61-2-9868-6733

Fax: 61-2-9868-6755

China - Beijing

Tel: 86-10-8569-7000

Fax: 86-10-8528-2104

China - Chengdu

Tel: 86-28-8665-5511

Fax: 86-28-8665-7889

China - Chongqing

Tel: 86-23-8980-9588

Fax: 86-23-8980-9500

China - Dongguan

Tel: 86-769-8702-9880

China - Guangzhou

Tel: 86-20-8755-8029

China - Hangzhou

Tel: 86-571-8792-8115

Fax: 86-571-8792-8116

China - Hong Kong SAR

Tel: 852-2943-5100

Fax: 852-2401-3431

China - Nanjing

Tel: 86-25-8473-2460

Fax: 86-25-8473-2470

China - Qingdao

Tel: 86-532-8502-7355

Fax: 86-532-8502-7205

China - Shanghai

Tel: 86-21-5407-5533

Fax: 86-21-5407-5066

China - Shenyang

Tel: 86-24-2334-2829

Fax: 86-24-2334-2393

China - Shenzhen

Tel: 86-755-8864-2200

Fax: 86-755-8203-1760

China - Wuhan

Tel: 86-27-5980-5300

Fax: 86-27-5980-5118

China - Xian

Tel: 86-29-8833-7252

Fax: 86-29-8833-7256

ASIA/PACIFIC

China - Xiamen

Tel: 86-592-2388138

Fax: 86-592-2388130

China - Zhuhai

Tel: 86-756-3210040

Fax: 86-756-3210049

India - Bangalore

Tel: 91-80-3090-4444

Fax: 91-80-3090-4123

India - New Delhi

Tel: 91-11-4160-8631

Fax: 91-11-4160-8632

India - Pune

Tel: 91-20-3019-1500

Japan - Osaka

Tel: 81-6-6152-7160

Fax: 81-6-6152-9310

Japan - Tokyo

Tel: 81-3-6880-3770

Fax: 81-3-6880-3771

Korea - Daegu

Tel: 82-53-744-4301

Fax: 82-53-744-4302

Korea - Seoul

Tel: 82-2-554-7200

Fax: 82-2-558-5932 or

82-2-558-5934

Malaysia - Kuala Lumpur

Tel: 60-3-6201-9857

Fax: 60-3-6201-9859

Malaysia - Penang

Tel: 60-4-227-8870

Fax: 60-4-227-4068

Philippines - Manila

Tel: 63-2-634-9065

Fax: 63-2-634-9069

Singapore

Tel: 65-6334-8870

Fax: 65-6334-8850

Taiwan - Hsin Chu

Tel: 886-3-5778-366

Fax: 886-3-5770-955

Taiwan - Kaohsiung

Tel: 886-7-213-7828

Taiwan - Taipei

Tel: 886-2-2508-8600

Fax: 886-2-2508-0102

Thailand - Bangkok

Tel: 66-2-694-1351

Fax: 66-2-694-1350

EUROPE

Austria - Wels

Tel: 43-7242-2244-39

Fax: 43-7242-2244-393

Denmark - Copenhagen

Tel: 45-4450-2828

Fax: 45-4485-2829

France - Paris

Tel: 33-1-69-53-63-20

Fax: 33-1-69-30-90-79

Germany - Dusseldorf

Tel: 49-2129-3766400

Germany - Karlsruhe

Tel: 49-721-625370

Germany - Munich

Tel: 49-89-627-144-0

Fax: 49-89-627-144-44

Italy - Milan

Tel: 39-0331-742611

Fax: 39-0331-466781

Italy - Venice

Tel: 39-049-7625286

Netherlands - Drunen

Tel: 31-416-690399

Fax: 31-416-690340

Poland - Warsaw

Tel: 48-22-3325737

Spain - Madrid

Tel: 34-91-708-08-90

Fax: 34-91-708-08-91

Sweden - Stockholm

Tel: 46-8-5090-4654

UK - Wokingham

Tel: 44-118-921-5800

Fax: 44-118-921-5820

06/23/16

Looking for pricing, stock, or lifecycle information?

Click below to explore more details on WIN SOURCE:

- ⊖ [View HV9110NG-G on WIN SOURCE](#)
- ⊖ [Microchip Technology](#) Information

Optimize Your Supply Chain with WIN SOURCE Solutions

- ✓ Global Sourcing Solution
- ✓ Obsolete Management
- ✓ Cost Control Management
- ✓ Shortage Management
- ✓ Alternative Solution
- ✓ Excess Inventory Management