



**THE DATASHEET OF  
87008AGILFT**





# ICS87008I

## LOW SKEW, 1-TO-8

### DIFFERENTIAL-TO-LVCMOS/LVTTL CLOCK GENERATOR

## GENERAL DESCRIPTION

The ICS87008I is a low skew, 1:8 LVCMOS/LVTTL Clock Generator. The device has 2 banks of 4 outputs and each bank can be independently selected for  $\pm 1$  or  $\pm 2$  frequency operation. Each bank also has its own power supply pins so that the banks can operate at the following different voltage levels: 3.3V, 2.5V, and 1.8V. The low impedance LVCMOS/LVTTL outputs are designed to drive 50 $\Omega$  series or parallel terminated transmission lines.

The divide select inputs, DIV\_SEL<sub>A</sub> and DIV\_SEL<sub>B</sub>, control the output frequency of each bank. The output banks can be independently selected for  $\pm 1$  or  $\pm 2$  operation. The bank enable inputs, CLK\_ENA and CLK\_ENB, support enabling and disabling each bank of outputs individually. The CLK\_ENA and CLK\_ENB circuitry has a synchronizer to prevent runt pulses when enabling or disabling the clock outputs. The master reset input, nMR/OE, resets the  $\pm 1/\pm 2$  flip flops and also controls the active and high impedance states of all outputs. This pin has an internal pull-up resistor and is normally used only for test purposes or in systems which use low power modes.

The ICS87008I is characterized to operate with the core at 3.3V or 2.5V and the banks at 3.3V, 2.5V, or 1.8V. Guaranteed bank, output, and part-to-part skew characteristics make the 87008I ideal for those clock applications demanding well-defined performance and repeatability.

## FEATURES

- Eight LVCMOS/LVTTL outputs (2 banks of 4 outputs)
- Selectable differential CLK1, nCLK1 or LVCMOS clock input
- CLK1, nCLK1 pair can accept the following differential input levels: LVPECL, LVDS, LVHSTL, SSTL, HCSL
- CLK0 supports the following input types: LVCMOS, LVTTL
- Maximum output frequency: 250MHz
- Independent bank control for  $\pm 1$  or  $\pm 2$  operation
- Glitchless, asynchronous clock enable/disable
- Output skew: 105ps (maximum) @ 3.3V core/3.3V output
- Bank skew: 70ps (maximum) @ 3.3V core/3.3V output
- 3.3V or 2.5V core/3.3V, 2.5V, or 1.8V output operating supply
- -40°C to 85°C ambient operating temperature
- Available in both standard and lead-free RoHS compliant packages

## BLOCK DIAGRAM

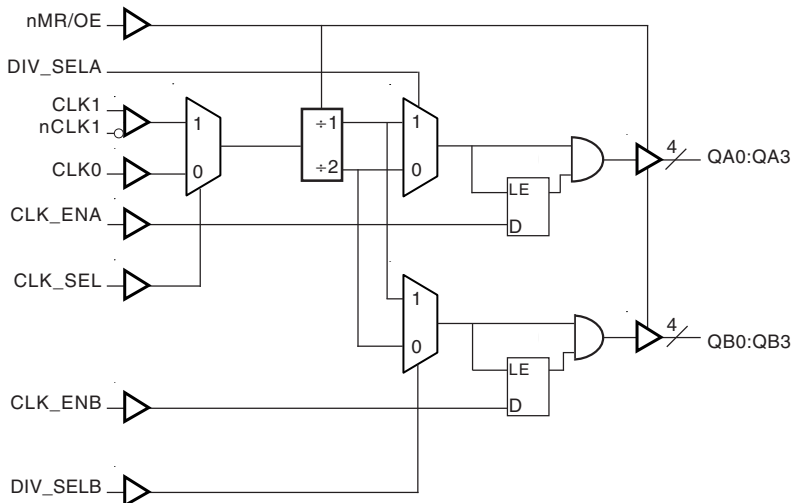

## PIN ASSIGNMENT

CLK1	1	24	CLK0
nCLK1	2	23	CLK_SEL
VDDOA	3	22	VDDOB
QA0	4	21	QB0
QA1	5	20	QB1
GND	6	19	GND
QA2	7	18	QB2
QA3	8	17	QB3
VDDOA	9	16	VDDOB
DIV_SEL_A	10	15	DIV_SEL_B
CLK_ENA	11	14	CLK_ENB
VDD	12	13	nMR/OE

**ICS87008I**  
**24-Lead TSSOP**  
 4.4mm x 7.8mm x 0.92mm body package  
**G Package**  
 Top View



# ICS87008I

## LOW SKEW, 1-TO-8 DIFFERENTIAL-TO-LVCMOS/LVTTL CLOCK GENERATOR

**TABLE 1. PIN DESCRIPTIONS**

Number	Name	Type		Description
1	CLK1	Input	Pulldown	Non-inverting differential clock input.
2	nCLK1	Input	Pullup/ Pulldown	Inverting differential clock input. $V_{DD}/2$ default when left floating.
3, 9	$V_{DDOA}$	Power		Output Bank A supply pins.
4, 5, 7, 8	QA0, QA1, QA2, QA3	Output		Bank A outputs. LVCMOS / LVTTL interface levels.
6, 19	GND	Power		Supply ground.
10	DIV_SELA	Input	Pullup	Controls frequency division for Bank A outputs. LVCMOS / LVTTL interface levels.
11	CLK_ENA	Input	Pullup	Output enable for Bank A outputs. Active HIGH. If pin is LOW, outputs drive low. LVCMOS / LVTTL interface levels.
12	$V_{DD}$	Power		Power supply pin.
13	nMR/OE	Input	Pullup	Master reset. When LOW, resets the $\div 1/\div 2$ flip flops and sets the outputs to high impedance. LVCMOS / LVTTL interface levels.
14	CLK_ENB	Input	Pullup	Output enable for Bank B outputs. Active HIGH. If pin is LOW, outputs drive low. LVCMOS / LVTTL interface levels.
15	DIV_SELB	Input	Pullup	Controls frequency division for Bank B outputs. LVCMOS / LVTTL interface levels..
16, 22	$V_{DDOB}$	Power		Output Bank B supply pins.
17, 18, 20, 21	QB3, QB2, QB1, QB0	Output		Bank B outputs. LVCMOS / LVTTL interface levels.
23	CLK_SEL	Input	Pulldown	Clock select input. When HIGH, selects CLK1, nCLK1 inputs. When LOW, selects CLK0 input. LVCMOS / LVTTL interface levels.
24	CLK0	Input	Pulldown	LVCMOS / LVTTL clock input.

NOTE: *Pullup* and *Pulldown* refer to internal input resistors. See Table 2, Pin Characteristics, for typical values.

**TABLE 2. PIN CHARACTERISTICS**

Symbol	Parameter	Test Conditions	Minimum	Typical	Maximum	Units
$C_{IN}$	Input Capacitance			4		pF
$R_{PULLUP}$	Input Pullup Resistor			51		k $\Omega$
$R_{PULLDOWN}$	Input Pulldown Resistor			51		k $\Omega$
$C_{PD}$	Power Dissipation Capacitance (per output)	$V_{DD}, V_{DDOx} = 3.465V$ ; NOTE 1			18	pF
		$V_{DD}, V_{DDOx} = 2.625V$ ; NOTE 1			20	pF
		$V_{DD} = 3.465, V_{DDOx} = 2.625V$ ; NOTE 1			20	pF
		$V_{DD} = 3.465, V_{DDOx} = 1.89V$ ; NOTE 1			30	pF
		$V_{DD} = 2.625, V_{DDOx} = 1.89V$ ; NOTE 1			20	pF
$R_{OUT}$	Output Impedance			7		$\Omega$

NOTE 1:  $V_{DDOx}$  denotes  $V_{DDOA}$  and  $V_{DDOB}$ .

**TABLE 3. FUNCTION TABLE**

Inputs			Outputs	
nMR/OE	CLK_ENx	DIV_SELx	Bank X	Qx Frequency
0	X	X	Hi Z	N/A
1	1	0	Active	f <sub>IN</sub> /2
1	1	1	Active	f <sub>IN</sub>
1	0	X	Low	N/A



# ICS87008I

## LOW SKEW, 1-TO-8 DIFFERENTIAL-TO-LVCMOS/LVTTL CLOCK GENERATOR

### ABSOLUTE MAXIMUM RATINGS

Supply Voltage, $V_{DD}$	4.6V
Inputs, $V_i$	-0.5V to $V_{DD} + 0.5$ V
Outputs, $V_o$	-0.5V to $V_{DD} + 0.5$ V
Package Thermal Impedance, $\theta_{JA}$	70°C/W (0 lfpm)
Storage Temperature, $T_{STG}$	-65°C to 150°C

NOTE: Stresses beyond those listed under Absolute Maximum Ratings may cause permanent damage to the device. These ratings are stress specifications only. Functional operation of product at these conditions or any conditions beyond those listed in the *DC Characteristics* or *AC Characteristics* is not implied. Exposure to absolute maximum rating conditions for extended periods may affect product reliability.

**TABLE 4A. POWER SUPPLY DC CHARACTERISTICS,  $V_{DD} = 3.3V \pm 5\%$  OR  $2.5V \pm 5\%$ ,  $T_A = -40^\circ\text{C}$  TO  $85^\circ\text{C}$**

Symbol	Parameter	Test Conditions	Minimum	Typical	Maximum	Units
$V_{DD}$	Power Supply Voltage		3.135	3.3	3.465	V
			2.375	2.5	2.625	V
$V_{DDOA}$ , $V_{DDOB}$	Output Supply Voltage; NOTE 1		3.135	3.3	3.465	V
			2.375	2.5	2.625	V
			1.71	1.8	1.89	V
$I_{DD}$	Power Supply Current			54	mA	
$I_{DDOA}$ , $I_{DDOB}$	Output Supply Current; NOTE 2			6.5	mA	



# ICS870081

## LOW SKEW, 1-TO-8 DIFFERENTIAL-TO-LVCMOS/LVTTL CLOCK GENERATOR

**TABLE 4B. LVCMOS/LVTTL DC CHARACTERISTICS,  $V_{DD} = 3.3V \pm 5\%$  OR  $2.5V \pm 5\%$ ,  $T_A = -40^\circ C$  TO  $85^\circ C$**

Symbol	Parameter	Test Conditions	Minimum	Typical	Maximum	Units
$V_{IH}$	Input High Voltage	DIV_SELA, DIV_SELB, CLK_ENA, CLK_ENB, nMR/OE, CLK_SEL	2		$V_{DD} + 0.3$	V
		CLK0	2		$V_{DD} + 0.3$	V
$V_{IL}$	Input Low Voltage	DIV_SELA, DIV_SELB, CLK_ENA, CLK_ENB, nMR/OE, CLK_SEL	-0.3		0.8	V
		CLK0	-0.3		1.3	V
$I_{IH}$	Input High Current	DIV_SELA, DIV_SELB, CLK_ENA, CLK_ENB, nMR/OE	$V_{DD} = V_{IN} = 3.465V$ , $V_{DD} = V_{IN} = 2.625V$		5	$\mu A$
		CLK0, CLK_SEL	$V_{DD} = V_{IN} = 3.465V$ , $V_{DD} = V_{IN} = 2.625V$		150	$\mu A$
$I_{IL}$	Input Low Current	DIV_SELA, DIV_SELB, CLK_ENA, CLK_ENB, nMR/OE	$V_{DD} = 3.465V, V_{IN} = 0V$ $V_{DD} = 2.625V, V_{IN} = 0V$	-150		$\mu A$
		CLK0, CLK_SEL	$V_{DD} = 3.465V, V_{IN} = 0V$ $V_{DD} = 2.625V, V_{IN} = 0V$	-5		$\mu A$
$V_{OH}$	Output High Voltage; NOTE 1	$V_{DDOX} = 3.3V \pm 5\%$ ; NOTE 2	2.6			V
		$V_{DDOX} = 2.5V \pm 5\%$ ; NOTE 2	1.8			V
		$V_{DDOX} = 1.8V \pm 5\%$ ; NOTE 2	1.5			V
$V_{OL}$	Output Low Voltage; NOTE 1	$V_{DDOX} = 3.3V \pm 5\%$ ; NOTE 2			0.5	V
		$V_{DDOX} = 2.5V \pm 5\%$ ; NOTE 2			0.5	V
		$V_{DDOX} = 1.8V \pm 5\%$ ; NOTE 2			0.4	V
$I_{OZL}$	Output Tristate Current Low		-5			$\mu A$
$I_{OZH}$	Output Tristate Current High				5	$\mu A$

NOTE 1: Outputs terminated with  $50\Omega$  to  $V_{DDOX}/2$ . See Parameter Measurement Information, Output Load Test Circuits.

NOTE 2:  $V_{DDOX}$  denotes  $V_{DDOA}$ , and  $V_{DDOB}$ .

**TABLE 4C. DIFFERENTIAL DC CHARACTERISTICS,  $V_{DD} = V_{DD} = 3.3V \pm 5\%$  OR  $2.5V \pm 5\%$ ,  $T_A = -40^\circ C$  TO  $85^\circ C$**

Symbol	Parameter	Test Conditions	Minimum	Typical	Maximum	Units
$I_{IH}$	Input High Current	nCLK1	$V_{IN} = V_{DD} = 3.465V$ , $V_{IN} = V_{DD} = 2.625V$		5	$\mu A$
		CLK1	$V_{IN} = V_{DD} = 3.465V$ , $V_{IN} = V_{DD} = 2.625V$		150	$\mu A$
$I_{IL}$	Input Low Current	nCLK1	$V_{IN} = 0V, V_{DD} = 3.465V$ , $V_{IN} = 0V, V_{DD} = 2.625V$	-150		$\mu A$
		CLK1	$V_{IN} = 0V, V_{DD} = 3.465V$ , $V_{IN} = 0V, V_{DD} = 2.625V$	-5		$\mu A$
$V_{PP}$	Peak-to-Peak Input Voltage		0.15		1.3	V
$V_{CMR}$	Common Mode Input Voltage; NOTE 1, 2		GND + 0.5		$V_{DD} - 0.85$	V

NOTE 1: For single ended applications, the maximum input voltage for CLK1, nCLK1 is  $V_{DD} + 0.3V$ .

NOTE 2: Common mode voltage is defined as  $V_{IH}$ .



# ICS87008I

## LOW SKEW, 1-TO-8 DIFFERENTIAL-TO-LVCMOS/LVTTL CLOCK GENERATOR

**TABLE 5A. AC CHARACTERISTICS,  $V_{DD} = V_{DDOX} = 3.3V \pm 5\%$ ,  $T_A = -40^\circ C$  TO  $85^\circ C$**

Symbol	Parameter	Test Conditions	Minimum	Typical	Maximum	Units
$f_{MAX}$	Output Frequency				250	MHz
$t_{pLH}$	Propagation Delay, Low to High	CLK0; NOTE 1A	1.9	3.5	5.1	ns
		CLK1, nCLK1; NOTE 1B	3.0	3.7	4.5	ns
$t_{sk(b)}$	Bank Skew; NOTE 2, 6				70	ps
$t_{sk(o)}$	Output Skew; NOTE 3, 6				105	ps
$t_{sk(pp)}$	Part-to-Part Skew; NOTE 4, 6				650	ps
$t_R / t_F$	Output Rise/Fall Time	20% to 80%	300		1100	ps
odc	Output Duty Cycle	$f \leq 133MHz$	45		55	%
$t_{EN}$	Output Enable Time; NOTE 5				10	ns
$t_{DIS}$	Output Disable Time; NOTE 5				10	ns

All parameters measured at 250MHz using CLK1, nCLK1 unless noted otherwise.

NOTE 1A: Measured from the  $V_{DD}/2$  of the input to  $V_{DDOX}/2$  of the output.

NOTE 1B: Measured from the differential input crossing point to  $V_{DDOX}/2$  of the output.

NOTE 2: Defined as skew within a bank with equal load conditions.

NOTE 3: Defined as skew between outputs at the same supply voltage and with equal load conditions.

Measured at  $V_{DDOX}/2$ .

NOTE 4: Defined as skew between outputs on different devices operating at the same supply voltages and with equal load conditions. Using the same type of input on each device, the output is measured at  $V_{DDOX}/2$ .

NOTE 5: These parameters are guaranteed by characterization. Not tested in production.

NOTE 6: This parameter is defined in accordance with JEDEC Standard 65.

**TABLE 5B. AC CHARACTERISTICS,  $V_{DD} = V_{DDOX} = 2.5V \pm 5\%$ ,  $T_A = -40^\circ C$  TO  $85^\circ C$**

Symbol	Parameter	Test Conditions	Minimum	Typical	Maximum	Units
$f_{MAX}$	Output Frequency				250	MHz
$t_{pLH}$	Propagation Delay, Low to High	CLK0; NOTE 1A	2.0	3.8	5.5	ns
		CLK1, nCLK1; NOTE 1B	3	4	5	ns
$t_{sk(b)}$	Bank Skew; NOTE 2, 6				35	ps
$t_{sk(o)}$	Output Skew; NOTE 3, 6				130	ps
$t_{sk(pp)}$	Part-to-Part Skew; NOTE 4, 6				1	ns
$t_R / t_F$	Output Rise/Fall Time	20% to 80%	300		1000	ps
odc	Output Duty Cycle	$f \leq 125MHz$	45		55	%
$t_{EN}$	Output Enable Time; NOTE 5				10	ns
$t_{DIS}$	Output Disable Time; NOTE 5				10	ns

All parameters measured at 250MHz using CLK1, nCLK1 unless noted otherwise.

NOTE 1A: Measured from the  $V_{DD}/2$  of the input to  $V_{DDOX}/2$  of the output.

NOTE 1B: Measured from the differential input crossing point to  $V_{DDOX}/2$  of the output.

NOTE 2: Defined as skew within a bank with equal load conditions.

NOTE 3: Defined as skew between outputs at the same supply voltage and with equal load conditions.

Measured at  $V_{DDOX}/2$ .

NOTE 4: Defined as skew between outputs on different devices operating at the same supply voltages and with equal load conditions. Using the same type of input on each device, the output is measured at  $V_{DDOX}/2$ .

NOTE 5: These parameters are guaranteed by characterization. Not tested in production.

NOTE 6: This parameter is defined in accordance with JEDEC Standard 65.



# ICS87008I

## LOW SKEW, 1-TO-8 DIFFERENTIAL-TO-LVCMOS/LVTTL CLOCK GENERATOR

**TABLE 5C. AC CHARACTERISTICS,  $V_{DD} = 3.3V \pm 5\%$ ,  $V_{DDOX} = 2.5V \pm 5\%$ ,  $T_A = -40^\circ C$  TO  $85^\circ C$**

Symbol	Parameter	Test Conditions	Minimum	Typical	Maximum	Units
$f_{MAX}$	Output Frequency				250	MHz
$t_{pLH}$	Propagation Delay, Low to High	CLK0; NOTE 1A	2.25	3.6	5.0	ns
		CLK1, nCLK1; NOTE 1B	3.1	3.8	4.4	ns
$t_{sk(b)}$	Bank Skew; NOTE 2, 6				60	ps
$t_{sk(o)}$	Output Skew; NOTE 3, 6				130	ps
$t_{sk(pp)}$	Part-to-Part Skew; NOTE 4, 6				900	ps
$t_R / t_F$	Output Rise/Fall Time	20% to 80%	290		950	ps
odc	Output Duty Cycle	$f \leq 133MHz$	45		55	%
$t_{EN}$	Output Enable Time; NOTE 5				10	ns
$t_{DIS}$	Output Disable Time; NOTE 5				10	ns

All parameters measured at 250MHz using CLK1, nCLK1 unless noted otherwise.

NOTE 1A: Measured from the  $V_{DD}/2$  of the input to  $V_{DDOX}/2$  of the output.

NOTE 1B: Measured from the differential input crossing point to  $V_{DDOX}/2$  of the output.

NOTE 2: Defined as skew within a bank with equal load conditions.

NOTE 3: Defined as skew between outputs at the same supply voltage and with equal load conditions.

Measured at  $V_{DDOX}/2$ .

NOTE 4: Defined as skew between outputs on different devices operating at the same supply voltages and with equal load conditions. Using the same type of input on each device, the output is measured at  $V_{DDOX}/2$ .

NOTE 5: These parameters are guaranteed by characterization. Not tested in production.

NOTE 6: This parameter is defined in accordance with JEDEC Standard 65.

**TABLE 5D. AC CHARACTERISTICS,  $V_{DD} = 3.3V \pm 5\%$ ,  $V_{DDOX} = 1.8V \pm 5\%$ ,  $T_A = -40^\circ C$  TO  $85^\circ C$**

Symbol	Parameter	Test Conditions	Minimum	Typical	Maximum	Units
$f_{MAX}$	Output Frequency				250	MHz
$t_{pLH}$	Propagation Delay, Low to High	CLK0; NOTE 1A	3.0	4.5	4.9	ns
		CLK1, nCLK1; NOTE 1B	3.3	4.1	5.0	ns
$t_{sk(b)}$	Bank Skew; NOTE 2, 6				55	ps
$t_{sk(o)}$	Output Skew; NOTE 3, 6				150	ps
$t_{sk(pp)}$	Part-to-Part Skew; NOTE 4, 6				1.1	ns
$t_R / t_F$	Output Rise/Fall Time	20% to 80%	280		850	ps
odc	Output Duty Cycle	$f \leq 133MHz$	45		55	%
$t_{EN}$	Output Enable Time; NOTE 5				10	ns
$t_{DIS}$	Output Disable Time; NOTE 5				10	ns

All parameters measured at 250MHz using CLK1, nCLK1 unless noted otherwise.

NOTE 1A: Measured from the  $V_{DD}/2$  of the input to  $V_{DDOX}/2$  of the output.

NOTE 1B: Measured from the differential input crossing point to  $V_{DDOX}/2$  of the output.

NOTE 2: Defined as skew within a bank with equal load conditions.

NOTE 3: Defined as skew between outputs at the same supply voltage and with equal load conditions.

Measured at  $V_{DDOX}/2$ .

NOTE 4: Defined as skew between outputs on different devices operating at the same supply voltages and with equal load conditions. Using the same type of input on each device, the output is measured at  $V_{DDOX}/2$ .

NOTE 5: These parameters are guaranteed by characterization. Not tested in production.

NOTE 6: This parameter is defined in accordance with JEDEC Standard 65.



# ICS87008I

## LOW SKEW, 1-TO-8 DIFFERENTIAL-TO-LVCMOS/LVTTL CLOCK GENERATOR

**TABLE 5E. AC CHARACTERISTICS,  $V_{DD} = 2.5V \pm 5\%$ ,  $V_{DDOX} = 1.8V \pm 5\%$ ,  $T_A = -40^\circ C$  TO  $85^\circ C$**

Symbol	Parameter	Test Conditions	Minimum	Typical	Maximum	Units
$f_{MAX}$	Output Frequency				250	MHz
$t_{pLH}$	Propagation Delay, Low to High	CLK0; NOTE 1A	2.6	4.1	5.6	ns
		CLK1, nCLK1; NOTE 1B	3.3	4.4	5.4	ns
$t_{sk(b)}$	Bank Skew; NOTE 2, 6				45	ps
$t_{sk(o)}$	Output Skew; NOTE 3, 6				150	ps
$t_{sk(pp)}$	Part-to-Part Skew; NOTE 4, 6				1.2	ns
$t_R / t_F$	Output Rise/Fall Time	20% to 80%	325		900	ps
odc	Output Duty Cycle	$f \leq 100MHz$	45		55	%
$t_{EN}$	Output Enable Time; NOTE 5				10	ns
$t_{DIS}$	Output Disable Time; NOTE 5				10	ns

All parameters measured at 250MHz using CLK1, nCLK1 unless noted otherwise.

NOTE 1A: Measured from the  $V_{DD}/2$  of the input to  $V_{DDOX}/2$  of the output.

NOTE 1B: Measured from the differential input crossing point to  $V_{DDOX}/2$  of the output.

NOTE 2: Defined as skew within a bank with equal load conditions.

NOTE 3: Defined as skew between outputs at the same supply voltage and with equal load conditions.

Measured at  $V_{DDOX}/2$ .

NOTE 4: Defined as skew between outputs on different devices operating at the same supply voltages and with equal load conditions. Using the same type of input on each device, the output is measured at  $V_{DDOX}/2$ .

NOTE 5: These parameters are guaranteed by characterization. Not tested in production.

NOTE 6: This parameter is defined in accordance with JEDEC Standard 65.



## PARAMETER MEASUREMENT INFORMATION

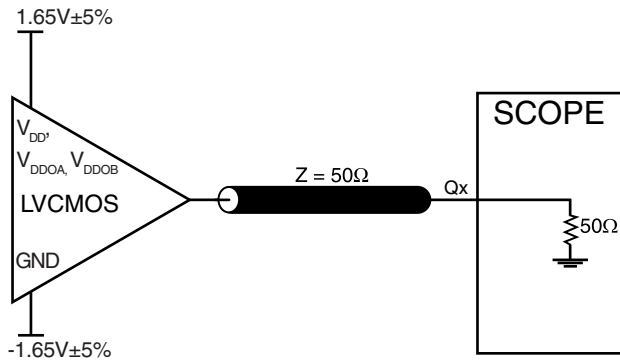

**3.3V CORE/3.3V OUTPUT LOAD AC TEST CIRCUIT**

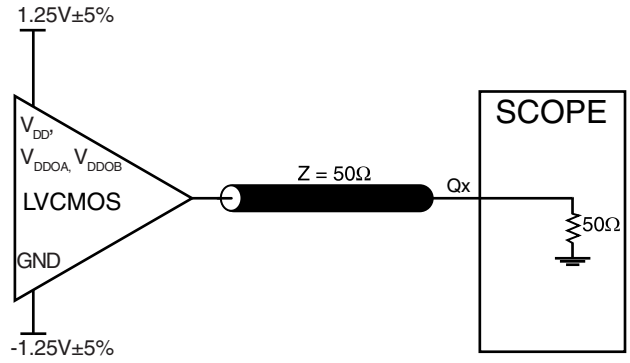

**2.5V CORE/2.5V OUTPUT LOAD AC TEST CIRCUIT**

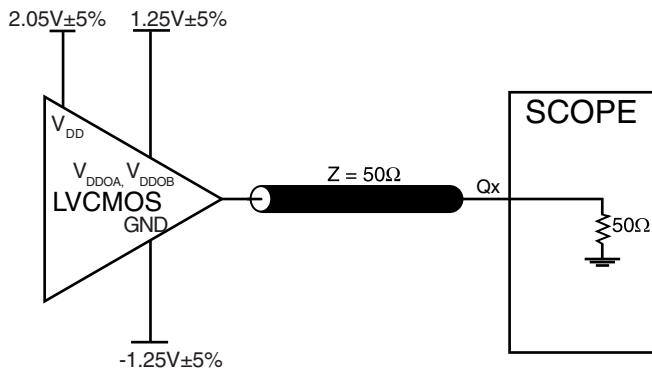

**3.3V CORE/2.5V OUTPUT LOAD AC TEST CIRCUIT**

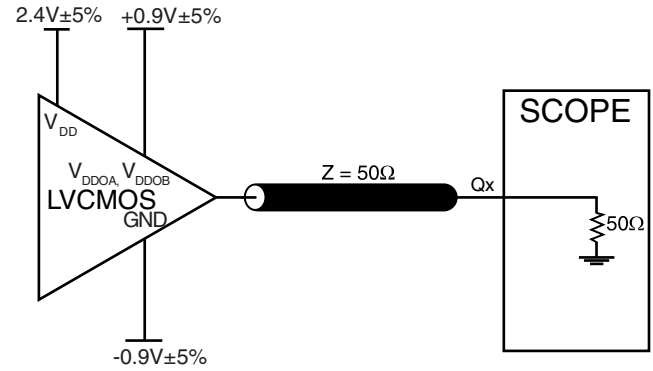

**3.3V CORE/1.8V OUTPUT LOAD AC TEST CIRCUIT**

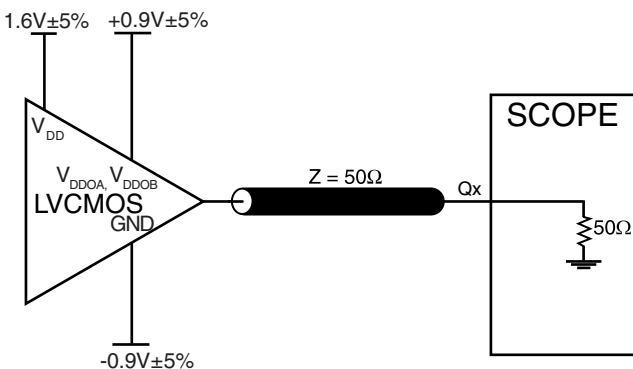

**2.5V CORE/1.8V OUTPUT LOAD AC TEST CIRCUIT**

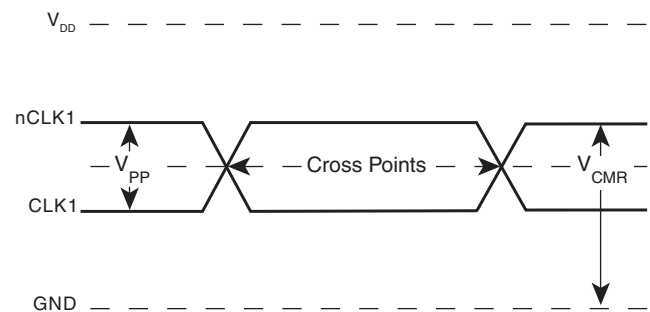

**DIFFERENTIAL INPUT LEVEL**



# ICS87008I

## LOW SKEW, 1-TO-8 DIFFERENTIAL-TO-LVCMOS/LVTTL CLOCK GENERATOR

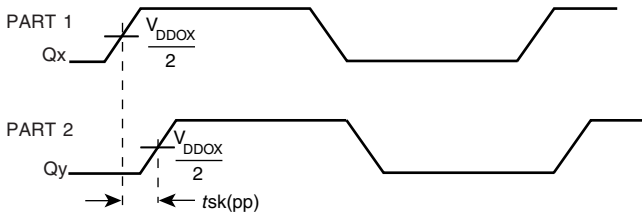

**PART-TO-PART SKEW**

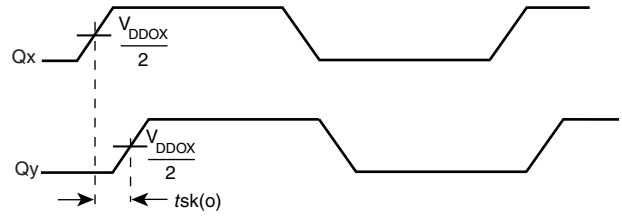

**OUTPUT SKEW**

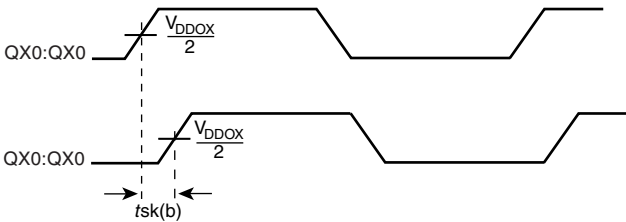

**BANK SKEW (where X denotes outputs in the same bank)**

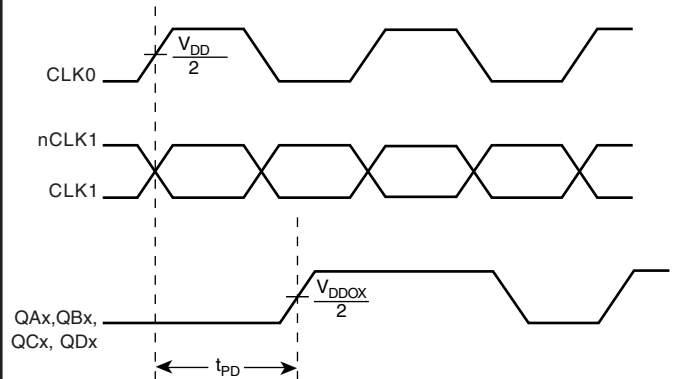

**PROPAGATION DELAY**

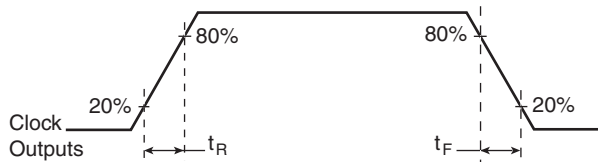

**OUTPUT RISE/FALL TIME**

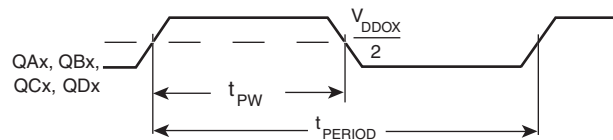

$$odc = \frac{t_{PW}}{t_{PERIOD}} \times 100\%$$

**OUTPUT DUTY CYCLE/PULSE WIDTH/PERIOD**

## APPLICATION INFORMATION

### WIRING THE DIFFERENTIAL INPUT TO ACCEPT SINGLE ENDED LEVELS

Figure 1 shows how the differential input can be wired to accept single ended levels. The reference voltage  $V_{REF} = V_{DD}/2$  is generated by the bias resistors R1, R2 and C1. This bias circuit should be located as close as possible to the input pin. The ratio

of R1 and R2 might need to be adjusted to position the  $V_{REF}$  in the center of the input voltage swing. For example, if the input clock swing is only 2.5V and  $V_{DD} = 3.3V$ ,  $V_{REF}$  should be 1.25V and  $R2/R1 = 0.609$ .

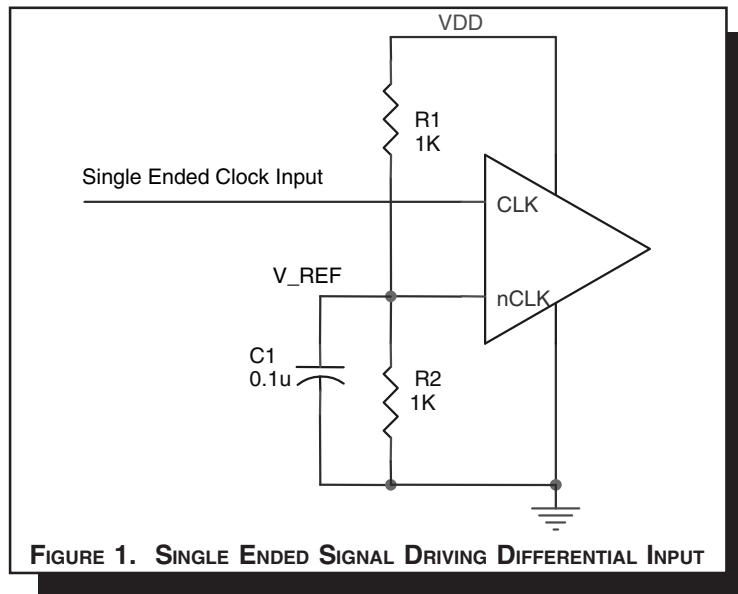

### RECOMMENDATIONS FOR UNUSED INPUT AND OUTPUT PINS

#### INPUTS:

##### CLK INPUT:

For applications not requiring the use of a clock input, it can be left floating. Though not required, but for additional protection, a 1kΩ resistor can be tied from the CLK input to ground.

##### CLK/nCLK INPUT:

For applications not requiring the use of the differential input, both CLK and nCLK can be left floating. Though not required, but for additional protection, a 1kΩ resistor can be tied from CLK to ground.

##### PCLK/nPCLK INPUT:

For applications not requiring the use of a differential input, both the PCLK and nPCLK pins can be left floating. Though not required, but for additional protection, a 1kΩ resistor can be tied from PCLK to ground.

#### LVCMOS CONTROL PINS:

All control pins have internal pull-ups or pull-downs; additional resistance is not required but can be added for additional protection. A 1kΩ resistor can be used.

#### OUTPUTS:

##### LVCMOS OUTPUT:

All unused LVCMOS output can be left floating. We recommend that there is no trace attached.

### DIFFERENTIAL CLOCK INPUT INTERFACE

The CLK/nCLK accepts LVDS, LVPECL, LVHSTL, SSTL, HCSL and other differential signals. Both  $V_{SWING}$  and  $V_{OH}$  must meet the  $V_{PP}$  and  $V_{CMR}$  input requirements. Figures 2A to 2E show interface examples for the CLK/nCLK input driven by the most common driver types. The input interfaces suggested here are

examples only. Please consult with the vendor of the driver component to confirm the driver termination requirements. For example in Figure 2A, the input termination applies for LVHSTL drivers. If you are using an LVHSTL driver from another vendor, use their termination recommendation.

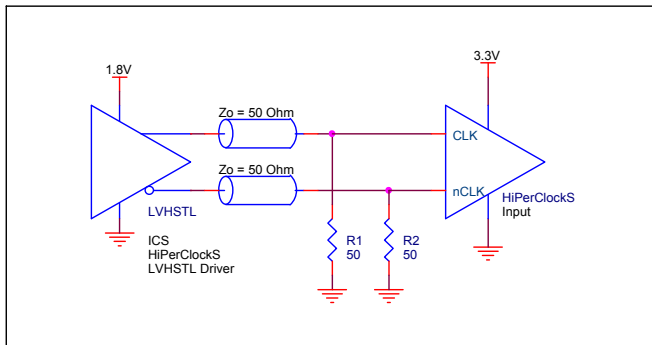

**FIGURE 2A. CLK/nCLK INPUT DRIVEN BY LVHSTL DRIVER**

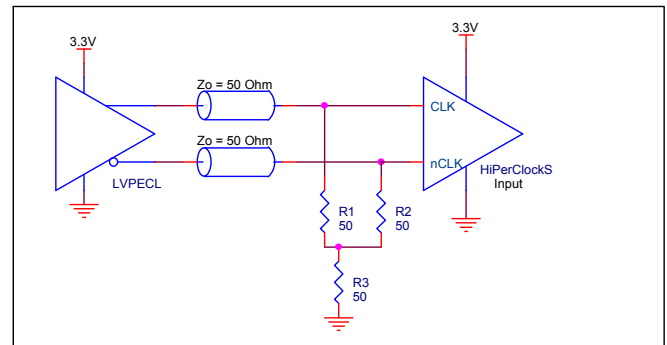

**FIGURE 2B. CLK/nCLK INPUT DRIVEN BY 3.3V LVPECL DRIVER**

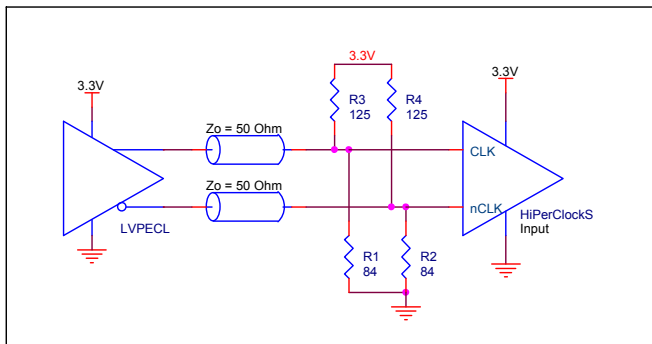

**FIGURE 2C. CLK/nCLK INPUT DRIVEN BY 3.3V LVPECL DRIVER**

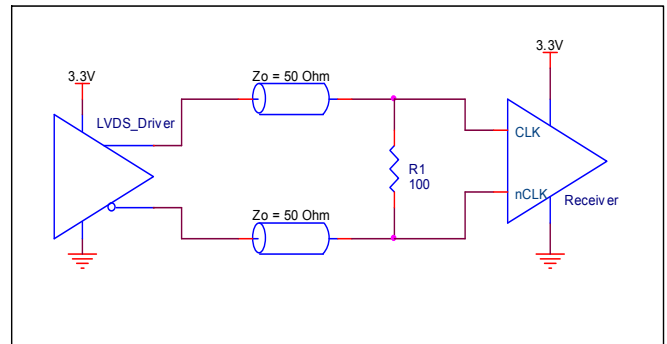

**FIGURE 2D. CLK/nCLK INPUT DRIVEN BY 3.3V LVDS DRIVER**

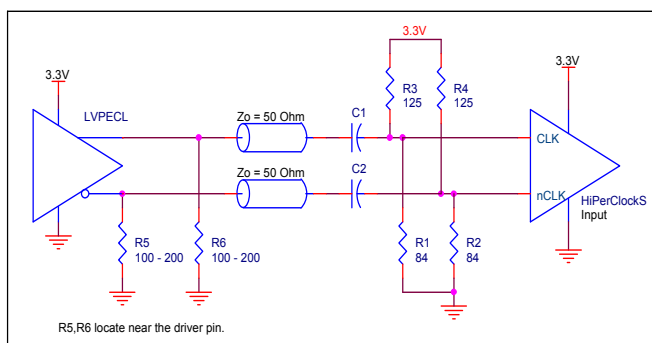

**FIGURE 2E. CLK/nCLK INPUT DRIVEN BY 3.3V LVPECL DRIVER WITH AC COUPLE**



## RELIABILITY INFORMATION

TABLE 6.  $\theta_{JA}$  VS. AIR FLOW TABLE FOR 24 LEAD TSSOP

$\theta_{JA}$ by Velocity (Linear Feet per Minute)			
	0	200	500
Multi-Layer PCB, JEDEC Standard Test Boards	70°C/W	63°C/W	60°C/W

### TRANSISTOR COUNT

The transistor count for ICS87008I is: 1262

PACKAGE OUTLINE - G SUFFIX FOR 24 LEAD TSSOP

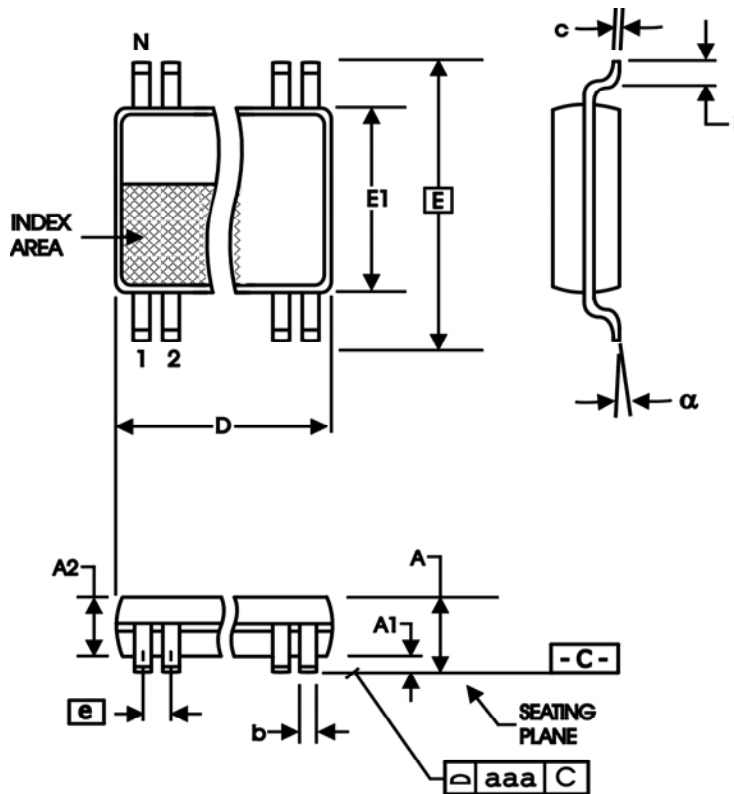

TABLE 7. PACKAGE DIMENSIONS

SYMBOL	Millimeters	
	Minimum	Maximum
N	24	
A	--	1.20
A1	0.05	0.15
A2	0.80	1.05
b	0.19	0.30
c	0.09	0.20
D	7.70	7.90
E	6.40 BASIC	
E1	4.30	4.50
e	0.65 BASIC	
L	0.45	0.75
α	0°	8°
aaa	--	0.10

Reference Document: JEDEC Publication 95, MS-153



**ICS87008I**  
LOW SKEW, 1-TO-8  
DIFFERENTIAL-TO-LVCMOS/LVTTL CLOCK GENERATOR

**TABLE 8. ORDERING INFORMATION**

<b>Part/Order Number</b>	<b>Marking</b>	<b>Package</b>	<b>Shipping Packaging</b>	<b>Temperature</b>
87008AGI	ICS87008AGI	24 Lead TSSOP	tray	-40°C to 85°C
87008AGIT	ICS87008AGI	24 Lead TSSOP	1000 tape & reel	-40°C to 85°C
87008AGILF	ICS87008AGILF	24 Lead "Lead-Free" TSSOP	tray	-40°C to 85°C
87008AGILFT	ICS87008AGILF	24 Lead "Lead-Free" TSSOP	1000 tape & reel	-40°C to 85°C

NOTE: Parts that are ordered with an "LF" suffix to the part number are the Pb-Free configuration and are RoHS compliant.

While the information presented herein has been checked for both accuracy and reliability, Integrated Device Technology, Inc. (IDT) assumes no responsibility for either its use or for infringement of any patents or other rights of third parties, which would result from its use. No other circuits, patents, or licenses are implied. This product is intended for use in normal commercial and industrial applications. Any other applications such as those requiring high reliability, or other extraordinary environmental requirements are not recommended without additional processing by IDT. IDT reserves the right to change any circuitry or specifications without notice. IDT does not authorize or warrant any IDT product for use in life support devices or critical medical instruments.



**ICS87008I**  
LOW SKEW, 1-TO-8  
DIFFERENTIAL-TO-LVCMOS/LVTTL CLOCK GENERATOR

REVISION HISTORY SHEET				
Rev	Table	Page	Description of Change	Date
A	T8	14	Ordering Information Table - added "T" (for tape and reel) Part/Order Number.	9/10/04
A	T8	10 14	Added <i>Recommendations for Unused Input and Output Pins</i> . Ordering Information Table - added lead-free part number, marking, and note.	2/21/06
B	T8	14 16	Updated datasheet's header/footer with IDT from ICS. Removed ICS prefix from Part/Order Number column. Added Contact Page.	7/31/10



**ICS87008I**  
LOW SKEW, 1-TO-8  
DIFFERENTIAL-TO-LVCMOS/LVTTL CLOCK GENERATOR

---

**We've Got Your Timing Solution.**



6024 Silver Creek Valley Road  
San Jose, CA 95138

**Sales**  
800-345-7015 (inside USA)  
+408-284-8200 (outside USA)  
Fax: 408-284-2775

**Tech Support**  
netcom@idt.com

© 2010 Integrated Device Technology, Inc. All rights reserved. Product specifications subject to change without notice. IDT, the IDT logo, ICS and HiPerClockS are trademarks of Integrated Device Technology, Inc. Accelerated Thinking is a service mark of Integrated Device Technology, Inc. All other brands, product names and marks are or may be trademarks or registered trademarks used to identify products or services of their respective owners.  
Printed in USA

## Looking for pricing, stock, or lifecycle information?

Click below to explore more details on WIN SOURCE:

- ⊖ [View 87008AGILFT on WIN SOURCE](#)
- ⊖ [IDT, Integrated Device Technology Inc Information](#)

## Optimize Your Supply Chain with WIN SOURCE Solutions

- ✓ Global Sourcing Solution
- ✓ Obsolete Management
- ✓ Cost Control Management
- ✓ Shortage Management
- ✓ Alternative Solution
- ✓ Excess Inventory Management