



# THE DATASHEET OF MSR1560G



# MSR1560G, MSRF1560G

## Switch-mode Soft Recovery Power Rectifier

These state-of-the-art devices are designed for boost converter or hard-switched converter applications, especially for Power Factor Correction application. It could also be used as a free wheeling diode in variable speed motor control applications and switching mode power supplies.

### Features

- Soft Recovery with Low Reverse Recovery Charge ( $Q_{RR}$ ) and Peak Reverse Recovery Current ( $I_{RRM}$ )
- Epoxy meets UL 94 V-0 @ 0.125 in
- Low Forward Voltage
- Low Leakage Current
- High Temperature Glass Passivated Junction
- These are Pb-Free Devices

### Mechanical Characteristics:

- Case: Epoxy, Molded
- Weight: 1.9 Grams (Approximately)
- Finish: All External Surfaces Corrosion Resistant and Terminal Leads Readily Solderable
- Lead Temperature for Soldering Purposes: 260°C Max. for 10 Seconds

### MAXIMUM RATINGS

Rating	Symbol	Value	Unit
Peak Repetitive Reverse Voltage Working Peak Reverse Voltage DC Blocking Voltage	$V_{RRM}$ $V_{RWM}$ $V_R$	600	V
Average Rectified Forward Current (At Rated $V_R$ , $T_C = 125^\circ\text{C}$ )	$I_O$	15	A
Peak Repetitive Forward Current (At Rated $V_R$ , Square Wave, 20 kHz, $T_C = 125^\circ\text{C}$ )	$I_{FRM}$	30	A
Non-Repetitive Peak Surge Current (Surge applied at rated load conditions, halfwave, single phase, 60 Hz)	$I_{FSM}$	100	A
Operating Junction and Storage Temperature Range	$T_J, T_{stg}$	-65 to +150	$^\circ\text{C}$

### THERMAL CHARACTERISTICS

Parameter	Symbol	Value	Unit
MSR1560G: Thermal Resistance Junction-to-Case Junction-to-Ambient	$R_{\theta JC}$ $R_{\theta JA}$	1.6 72.8	$^\circ\text{C/W}$
MSRF1560G: Thermal Resistance Junction-to-Case Junction-to-Ambient	$R_{\theta JC}$ $R_{\theta JA}$	4.25 75	$^\circ\text{C/W}$

Stresses exceeding those listed in the Maximum Ratings table may damage the device. If any of these limits are exceeded, device functionality should not be assumed, damage may occur and reliability may be affected.



**ON Semiconductor®**

<http://onsemi.com>

## SOFT RECOVERY POWER RECTIFIER 15 AMPERES, 600 VOLTS

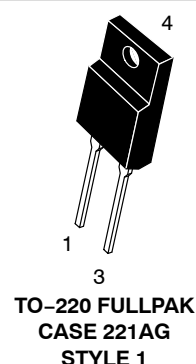
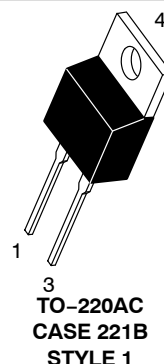
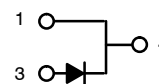

### MARKING DIAGRAMS

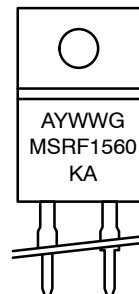
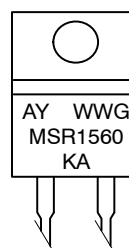

- A = Assembly Location
- Y = Year
- WW = Work Week
- G = Pb-Free Package
- KA = Diode Polarity

### ORDERING INFORMATION

Device	Package	Shipping
MSR1560G	TO-220AC (Pb-Free)	50 Units/Rail
MSRF1560G	TO-220FP (Pb-Free)	50 Units/Rail

# MSR1560G, MSRF1560G

## ELECTRICAL CHARACTERISTICS

Characteristic	Symbol	Value		Unit
		$T_J = 25^\circ\text{C}$	$T_J = 150^\circ\text{C}$	
Instantaneous Forward Voltage (Note 1) ( $I_F = 15\text{ A}$ ) Maximum Typical	$V_F$	1.8 1.5	1.4 1.2	V
		$T_J = 25^\circ\text{C}$	$T_J = 150^\circ\text{C}$	
Instantaneous Reverse Current ( $V_R = 600\text{ V}$ ) Maximum Typical	$I_R$	15 0.4	5000 100	$\mu\text{A}$
		$T_J = 25^\circ\text{C}$	$T_J = 150^\circ\text{C}$	
Reverse Recovery Time (Note 2) ( $V_R = 30\text{ V}$ , $I_F = 1\text{ A}$ , $di/dt = 100\text{ A}/\mu\text{s}$ ) Maximum Typical	$t_{rr}$	45 35	65 54	ns
		$T_J = 25^\circ\text{C}$	$T_J = 100^\circ\text{C}$	
Typical Recovery Softness Factor ( $V_R = 30\text{ V}$ , $I_F = 1\text{ A}$ , $di/dt = 100\text{ A}/\mu\text{s}$ )	$s = t_b/t_a$	0.67	0.74	
Typical Peak Reverse Recovery Current ( $V_R = 30\text{ V}$ , $I_F = 1\text{ A}$ , $di/dt = 100\text{ A}/\mu\text{s}$ )	$I_{RRM}$	2.3	3.2	A
Typical Reverse Recovery Charge ( $V_R = 30\text{ V}$ , $I_F = 1\text{ A}$ , $di/dt = 100\text{ A}/\mu\text{s}$ )	$Q_{RR}$	31	78	nC

Product parametric performance is indicated in the Electrical Characteristics for the listed test conditions, unless otherwise noted. Product performance may not be indicated by the Electrical Characteristics if operated under different conditions.

1. Pulse Test: Pulse Width  $\leq 380\ \mu\text{s}$ , Duty Cycle  $\leq 2\%$
2.  $T_{RR}$  measured projecting from 25% of  $I_{RRM}$  to zero current

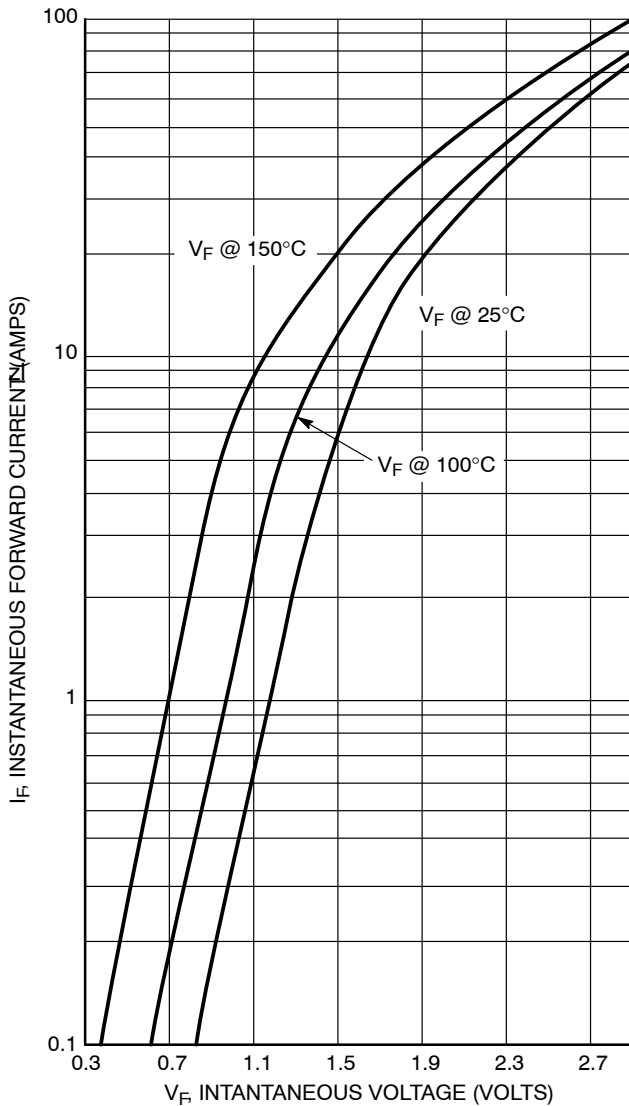

Figure 1. Maximum Forward Voltage

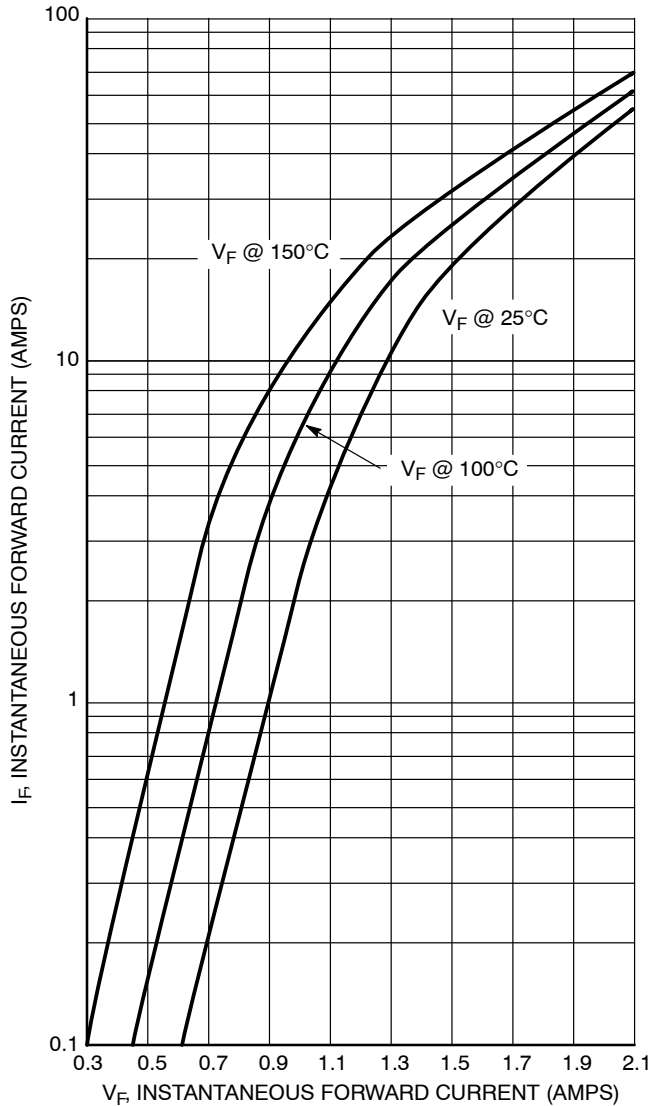
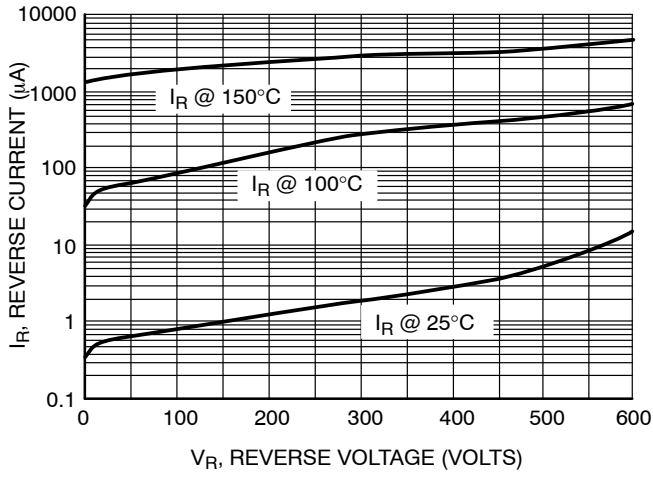
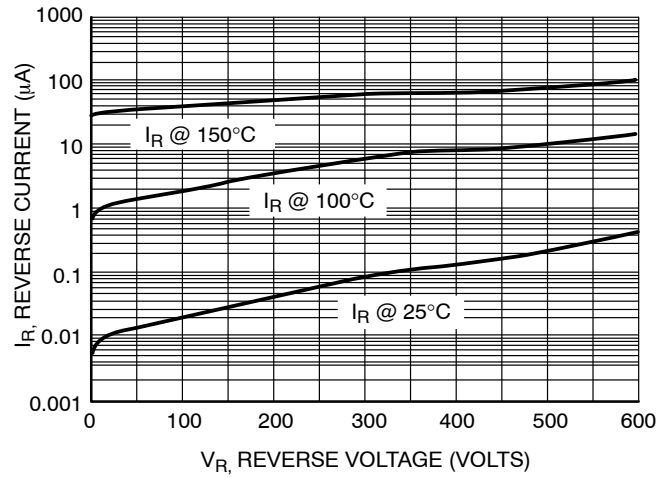

Figure 2. Typical Forward Voltage

# MSR1560G, MSRF1560G



**Figure 3. Maximum Reverse Current**



**Figure 4. Typical Reverse Current**

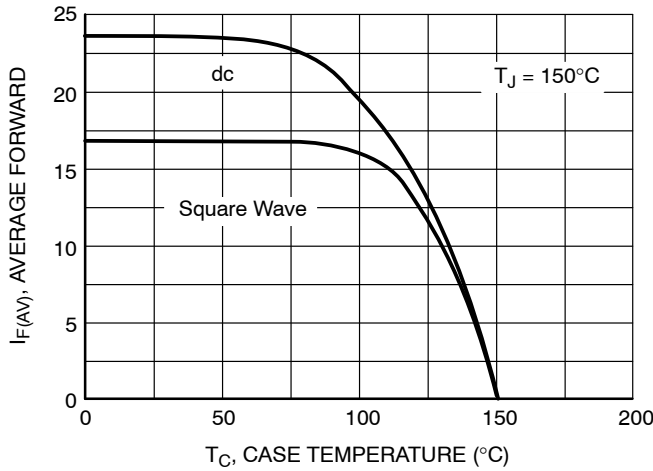

**Figure 5. Current Derating**

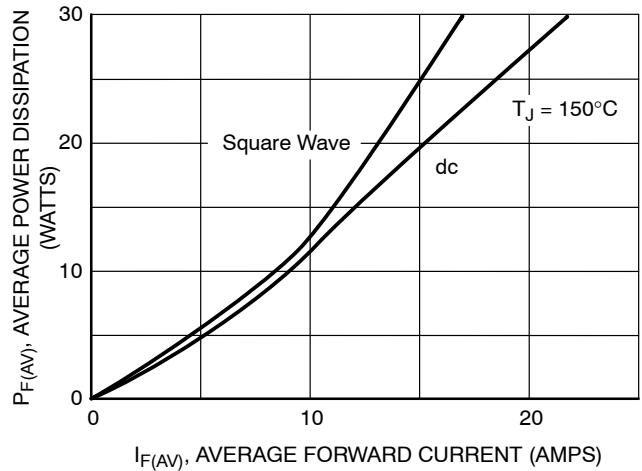

**Figure 6. Power Dissipation**

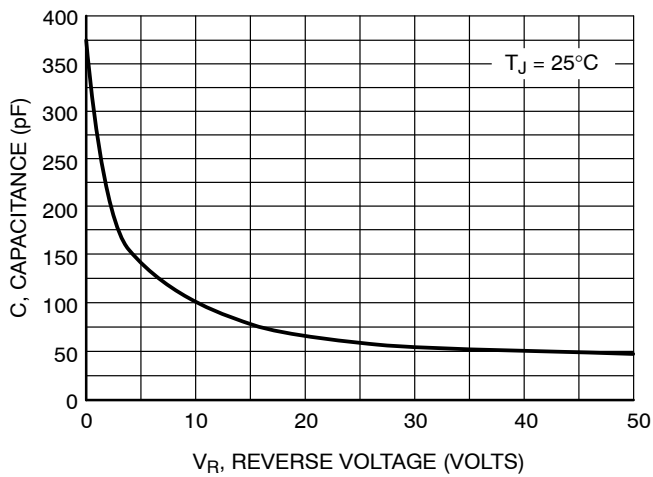

**Figure 7. Maximum Capacitance**

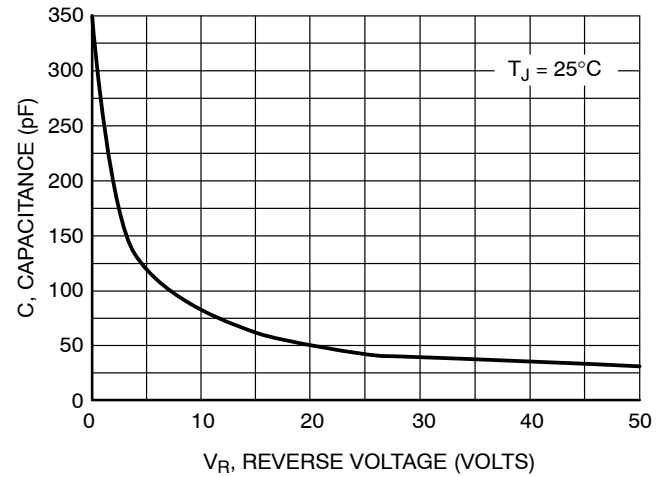

**Figure 8. Typical Capacitance**

# MSR1560G, MSRF1560G

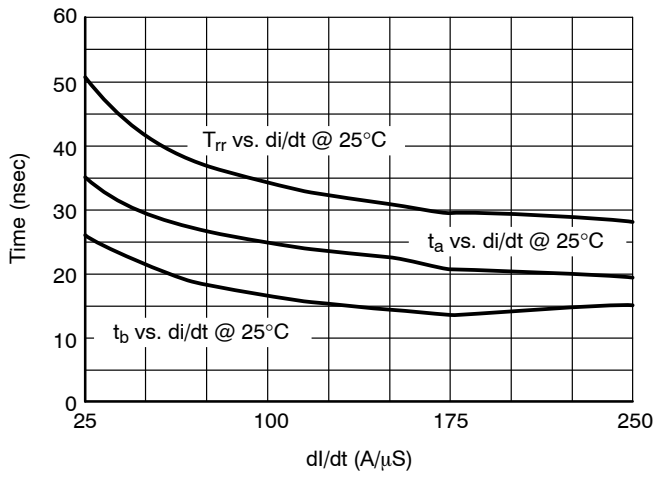

Figure 9. Typical Trr vs. di/dt

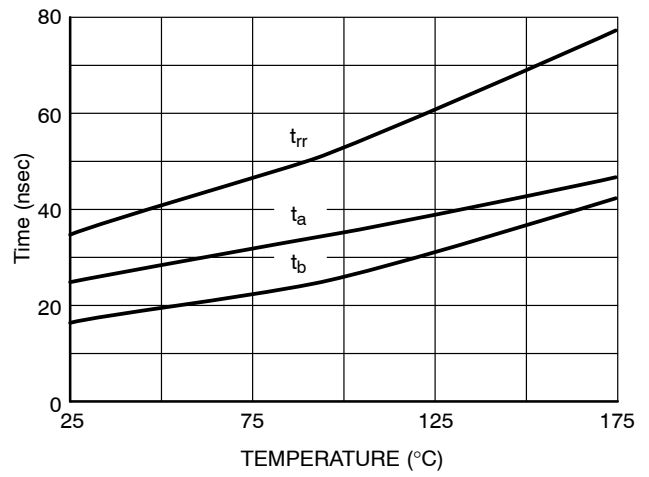

Figure 10. Typical Trr vs. Temperature

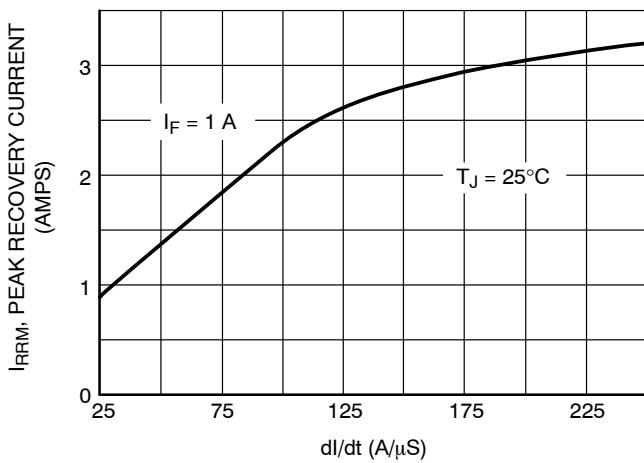

Figure 11. Typical Peak Reverse Recovery Current

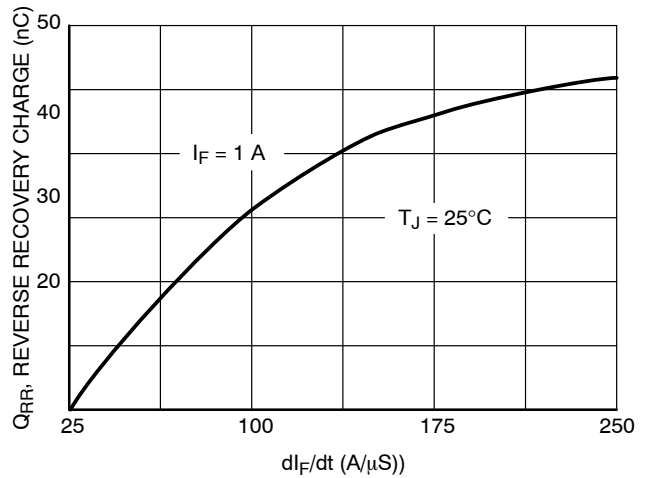

Figure 12. Typical Reverse Recovery Charge

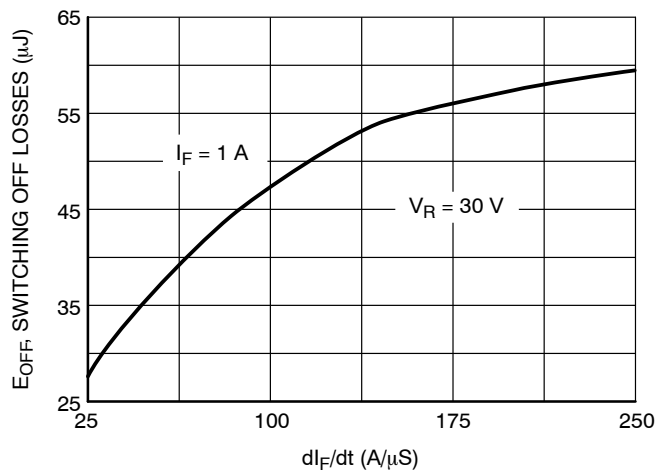

Figure 13. Typical Switching Off Losses

# MSR1560G, MSRF1560G

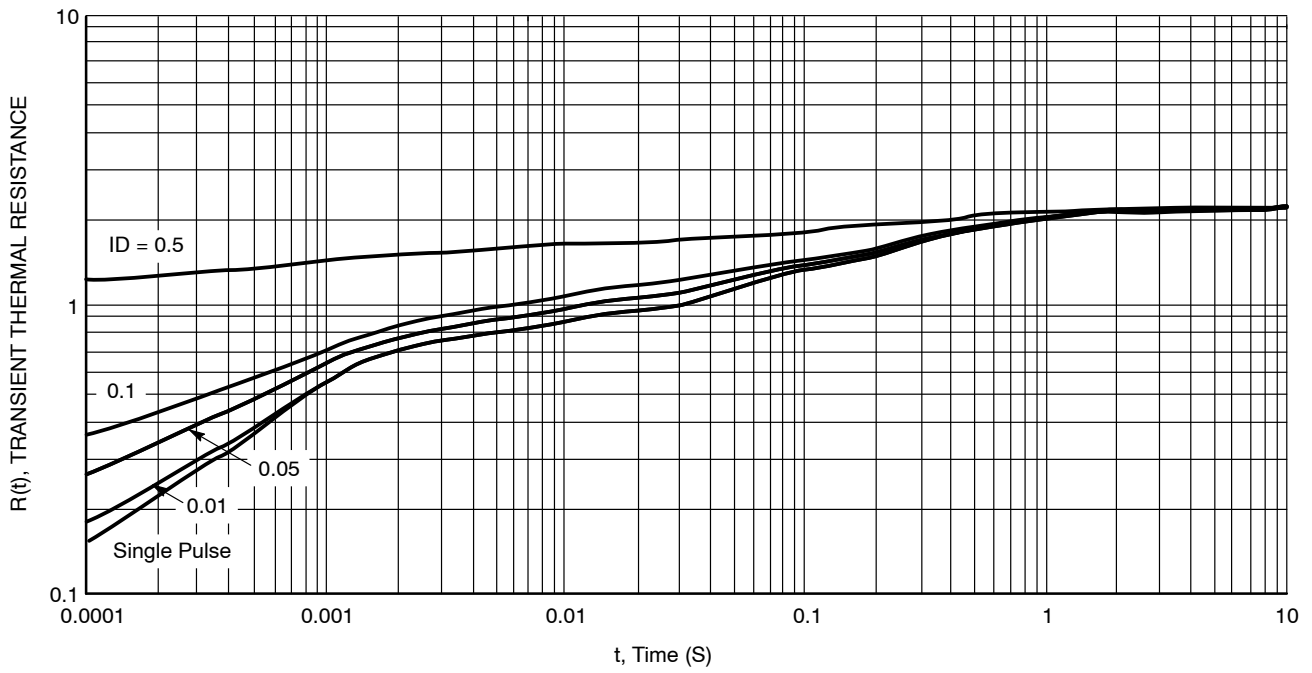

Figure 14. Transient Thermal Response

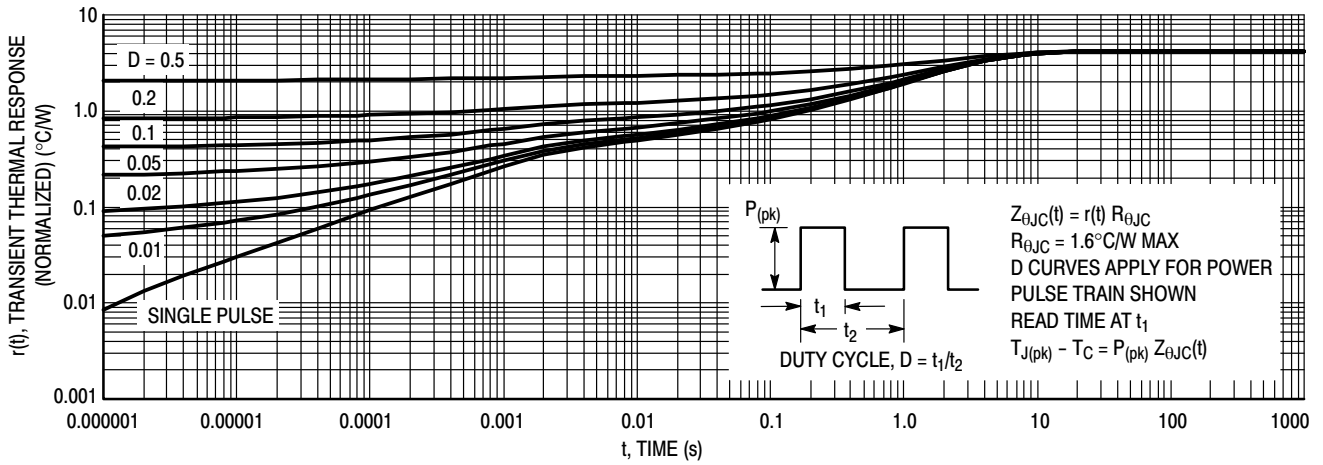

Figure 15. Thermal Response, (MSRF1560) Junction-to-Case ( $R_{\theta JC}$ )

# MSR1560G, MSRF1560G

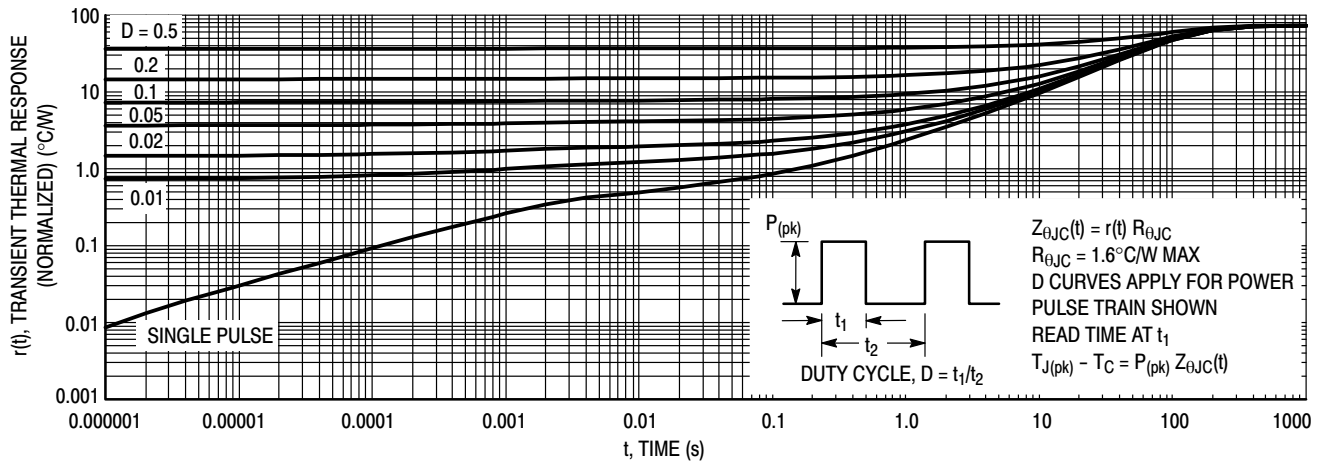
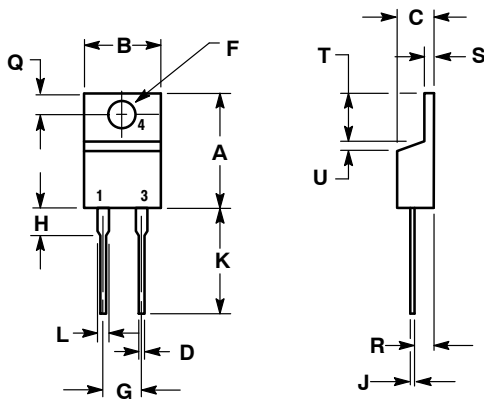

Figure 16. Thermal Response, (MSRF1560) Junction-to-Ambient ( $R_{\theta JA}$ )

# MSR1560G, MSRF1560G

## PACKAGE DIMENSIONS

### TO-220 TWO-LEAD CASE 221B-04 ISSUE F



- NOTES:  
1. DIMENSIONING AND TOLERANCING PER ANSI Y14.5M, 1982.  
2. CONTROLLING DIMENSION: INCH.

DIM	INCHES		MILLIMETERS	
	MIN	MAX	MIN	MAX
A	0.595	0.620	15.11	15.75
B	0.380	0.405	9.65	10.29
C	0.160	0.190	4.06	4.82
D	0.025	0.039	0.64	1.00
F	0.142	0.161	3.61	4.09
G	0.190	0.210	4.83	5.33
H	0.110	0.130	2.79	3.30
J	0.014	0.025	0.36	0.64
K	0.500	0.562	12.70	14.27
L	0.045	0.060	1.14	1.52
Q	0.100	0.120	2.54	3.04
R	0.080	0.110	2.04	2.79
S	0.045	0.055	1.14	1.39
T	0.235	0.255	5.97	6.48
U	0.000	0.050	0.000	1.27

- STYLE 1:  
PIN 1. CATHODE  
2. N/A  
3. ANODE  
4. CATHODE

### TO-220 FULLPAK, 2-LEAD CASE 221AG ISSUE A

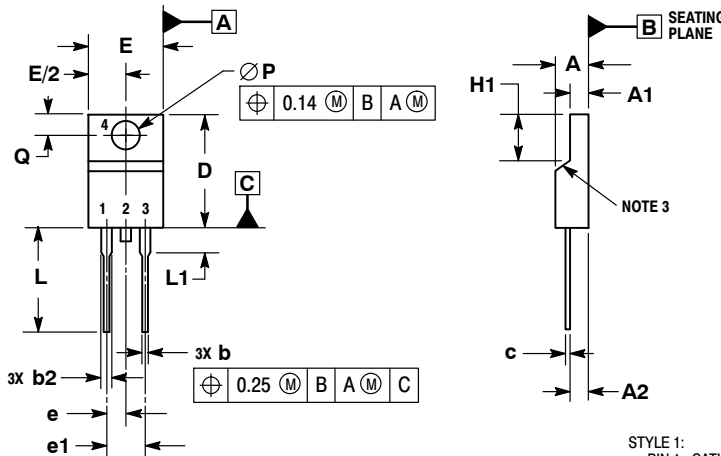

- NOTES:  
1. DIMENSIONING AND TOLERANCING PER ASME Y14.5M, 1994.  
2. CONTROLLING DIMENSION: MILLIMETERS.  
3. CONTOUR UNCONTROLLED IN THIS AREA.  
4. DIMENSIONS D AND E DO NOT INCLUDE MOLD FLASH AND GATE PROTRUSIONS. MOLD FLASH AND GATE PROTRUSIONS NOT TO EXCEED 0.13 PER SIDE. THESE DIMENSIONS ARE TO BE MEASURED AT OUTERMOST EXTREME OF THE PLASTIC BODY.  
5. DIMENSION b2 DOES NOT INCLUDE DAMBAR PROTRUSION. LEAD WIDTH INCLUDING PROTRUSION SHALL NOT EXCEED 2.00.

DIM	MILLIMETERS	
	MIN	MAX
A	4.30	4.70
A1	2.50	2.90
A2	2.50	2.90
b	0.54	0.84
b2	1.10	1.40
c	0.49	0.79
D	14.22	15.88
E	9.65	10.67
e	2.54 BSC	
e1	5.08 BSC	
H1	5.97	6.48
L	12.70	14.73
L1	---	2.80
P	3.00	3.40
Q	2.80	3.20

- STYLE 1:  
PIN 1. CATHODE  
2. N/A  
3. ANODE

ON Semiconductor and are registered trademarks of Semiconductor Components Industries, LLC (SCILLC). SCILLC owns the rights to a number of patents, trademarks, copyrights, trade secrets, and other intellectual property. A listing of SCILLC's product/patent coverage may be accessed at [www.onsemi.com/site/pdf/Patent-Marking.pdf](http://www.onsemi.com/site/pdf/Patent-Marking.pdf). SCILLC reserves the right to make changes without further notice to any products herein. SCILLC makes no warranty, representation or guarantee regarding the suitability of its products for any particular purpose, nor does SCILLC assume any liability arising out of the application or use of any product or circuit, and specifically disclaims any and all liability, including without limitation special, consequential or incidental damages. "Typical" parameters which may be provided in SCILLC data sheets and/or specifications can and do vary in different applications and actual performance may vary over time. All operating parameters, including "Typicals" must be validated for each customer application by customer's technical experts. SCILLC does not convey any license under its patent rights nor the rights of others. SCILLC products are not designed, intended, or authorized for use as components in systems intended for surgical implant into the body, or other applications intended to support or sustain life, or for any other application in which the failure of the SCILLC product could create a situation where personal injury or death may occur. Should Buyer purchase or use SCILLC products for any such unintended or unauthorized application, Buyer shall indemnify and hold SCILLC and its officers, employees, subsidiaries, affiliates, and distributors harmless against all claims, costs, damages, and expenses, and reasonable attorney fees arising out of, directly or indirectly, any claim of personal injury or death associated with such unintended or unauthorized use, even if such claim alleges that SCILLC was negligent regarding the design or manufacture of the part. SCILLC is an Equal Opportunity/Affirmative Action Employer. This literature is subject to all applicable copyright laws and is not for resale in any manner.

## PUBLICATION ORDERING INFORMATION

**LITERATURE FULFILLMENT:**  
Literature Distribution Center for ON Semiconductor  
P.O. Box 5163, Denver, Colorado 80217 USA  
Phone: 303-675-2175 or 800-344-3860 Toll Free USA/Canada  
Fax: 303-675-2176 or 800-344-3867 Toll Free USA/Canada  
Email: [orderlit@onsemi.com](mailto:orderlit@onsemi.com)

**N. American Technical Support:** 800-282-9855 Toll Free  
USA/Canada  
**Europe, Middle East and Africa Technical Support:**  
Phone: 421 33 790 2910  
**Japan Customer Focus Center**  
Phone: 81-3-5817-1050

**ON Semiconductor Website:** [www.onsemi.com](http://www.onsemi.com)  
**Order Literature:** <http://www.onsemi.com/orderlit>  
For additional information, please contact your local Sales Representative

## Looking for pricing, stock, or lifecycle information?

Click below to explore more details on WIN SOURCE:

 [View MSR1560G on WIN SOURCE](#)

 [ON Semiconductor](#) Information

## Optimize Your Supply Chain with WIN SOURCE Solutions

-  Global Sourcing Solution
-  Obsolete Management
-  Cost Control Management
-  Shortage Management
-  Alternative Solution
-  Excess Inventory Management