



**THE DATASHEET OF  
LT8705EFE#PBF**



# 80V $V_{IN}$ and $V_{OUT}$ Synchronous 4-Switch Buck-Boost DC/DC Controller

## FEATURES

- Single Inductor Allows  $V_{IN}$  Above, Below, or Equal to Regulated  $V_{OUT}$
- $V_{IN}$  Range 2.8V (Need  $EXTV_{CC} > 6.4V$ ) to 80V
- $V_{OUT}$  Range: 1.3V to 80V
- Quad N-Channel MOSFET Gate Drivers
- Synchronous Rectification: Up to 98% Efficiency
- Input and Output Current Monitor Pins
- Synchronizable Fixed Frequency: 100kHz to 400kHz
- Integrated Input Current, Input Voltage, Output Current and Output Voltage Feedback Loops
- Clock Output Usable To Monitor Die Temperature
- Available in 38-Lead (5mm × 7mm) QFN and TSSOP Packages with the TSSOP Modified for Improved High Voltage Operation

## APPLICATIONS

- High Voltage Buck-Boost Converters
- Input or Output Current Limited Converters

## DESCRIPTION

The **LT<sup>®</sup>8705** is a high performance buck-boost switching regulator controller that operates from input voltages above, below or equal to the output voltage. The part has integrated input current, input voltage, output current and output voltage feedback loops. With a wide 2.8V to 80V input and 1.3V to 80V output range, the LT8705 is compatible with most solar, automotive, telecom and battery-powered systems.

The LT8705 includes servo pins to indicate which feedback loops are active. The MODE pin selects among Burst Mode<sup>®</sup> operation, discontinuous or continuous conduction mode at light loads. Additional features include a 3.3V/12mA LDO, a synchronizable fixed operating frequency, onboard gate drivers, adjustable UVLO, along with input and output current monitoring with programmable maximum levels.

LT, LT, LTC, LTM, Linear Technology, Burst Mode, µModule and the Linear logo are registered trademarks of Linear Technology Corporation. All other trademarks are the property of their respective owners.

## TYPICAL APPLICATION

Telecom Voltage Stabilizer

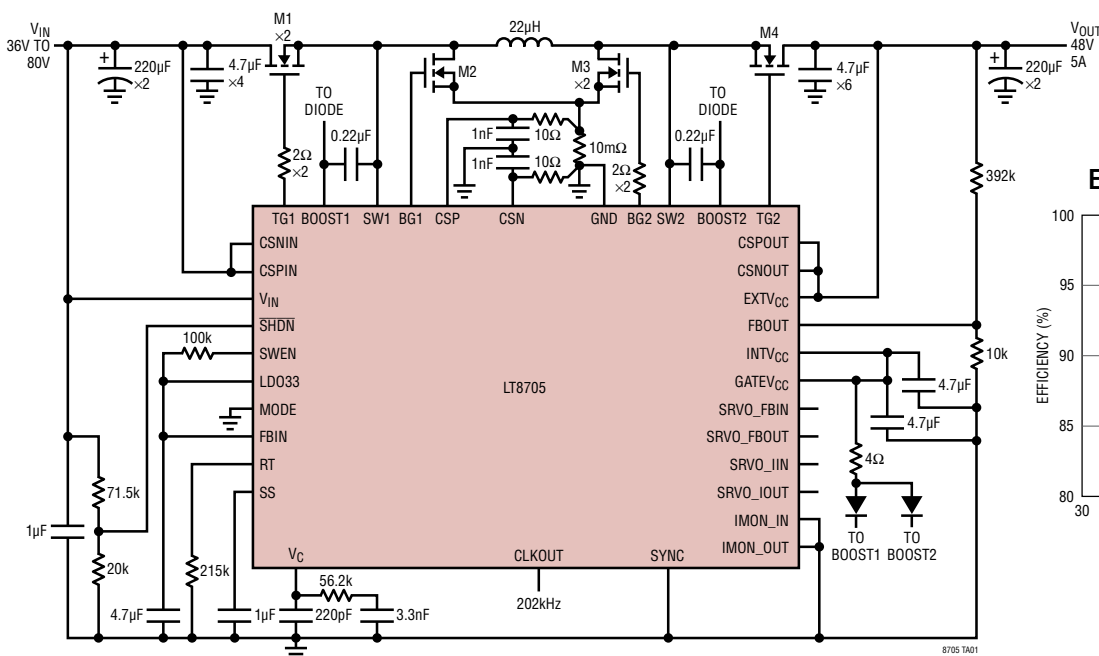

Efficiency and Power Loss

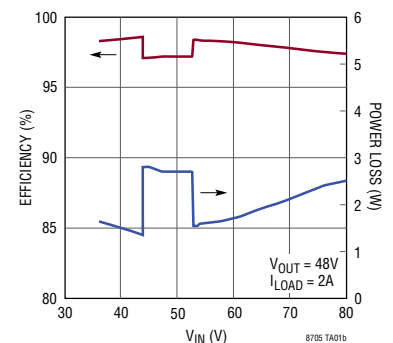

## ABSOLUTE MAXIMUM RATINGS (Note 1)

$V_{CSP}-V_{CSN}$ , $V_{CSPIN}-V_{CSNIN}$	
$V_{CSPOUT}-V_{CSNOUT}$ .....	-0.3V to 0.3V
SS, CLKOUT, CSP, CSN Voltage .....	-0.3V to 3V
$V_C$ Voltage (Note 2).....	-0.3V to 2.2V
RT, LDO33, FBOUT Voltage.....	-0.3V to 5V
IMON_IN, IMON_OUT Voltage .....	-0.3V to 5V
SYNC Voltage.....	-0.3V to 5.5V
INTV <sub>CC</sub> , GATEV <sub>CC</sub> Voltage.....	-0.3V to 7V
$V_{BOOST1}-V_{SW1}$ , $V_{BOOST2}-V_{SW2}$ .....	-0.3V to 7V
SWEN, MODE Voltage.....	-0.3V to 7V
SRVO_FBIN, SRVO_FBOUT Voltage.....	-0.3V to 30V
SRVO_IIN, SRVO_IOUT Voltage.....	-0.3V to 30V
FBIN, SHDN Voltage.....	-0.3V to 30V

CSNIN, CSPIN, CSPOUT, CSNOUT Voltage ..	-0.3V to 80V
$V_{IN}$ , EXTV <sub>CC</sub> Voltage .....	-0.3V to 80V
SW1, SW2 Voltage.....	81V (Note 7)
BOOST1, BOOST2 Voltage .....	-0.3V to 87V
BG1, BG2, TG1, TG2 .....	(Note 6)
Operating Junction Temperature Range	
LT8705E (Notes 3, 8) .....	-40°C to 125°C
LT8705I (Notes 3, 8) .....	-40°C to 125°C
LT8705H (Notes 3, 8).....	-40°C to 150°C
LT8705MP (Notes 3, 8).....	-55°C to 150°C
Storage Temperature Range .....	-65°C to 150°C
Lead Temperature (Soldering, 10 sec)	
FE Package .....	300°C

## PIN CONFIGURATION

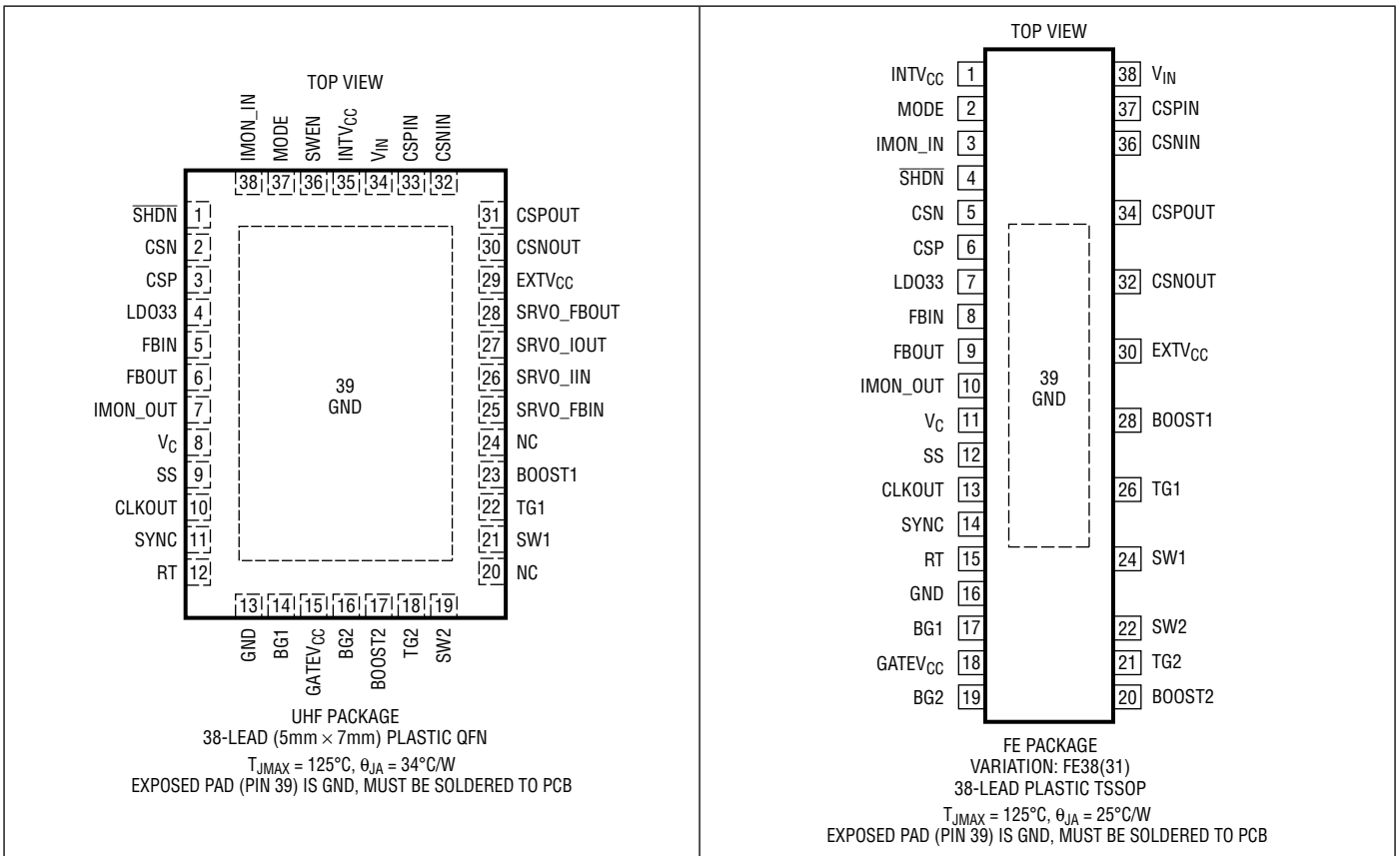

## ORDER INFORMATION

LEAD FREE FINISH	TAPE AND REEL	PART MARKING*	PACKAGE DESCRIPTION	TEMPERATURE RANGE
LT8705EUHF#PBF	LT8705EUHF#TRPBF	8705	38-Lead (5mm × 7mm) Plastic QFN	-40°C to 125°C
LT8705IUHF#PBF	LT8705IUHF#TRPBF	8705	38-Lead (5mm × 7mm) Plastic QFN	-40°C to 125°C
LT8705EFE#PBF	LT8705EFE#TRPBF	LT8705FE	38-Lead Plastic TSSOP	-40°C to 125°C
LT8705IFE#PBF	LT8705IFE#TRPBF	LT8705FE	38-Lead Plastic TSSOP	-40°C to 125°C
LT8705HFE#PBF	LT8705HFE#TRPBF	LT8705FE	38-Lead Plastic TSSOP	-40°C to 150°C
LT8705MPFE#PBF	LT8705MPFE#TRPBF	LT8705FE	38-Lead Plastic TSSOP	-55°C to 150°C

Consult LTC Marketing for parts specified with wider operating temperature ranges. \*The temperature grade is identified by a label on the shipping container.

For more information on lead free part marking, go to: <http://www.linear.com/leadfree/>

For more information on tape and reel specifications, go to: <http://www.linear.com/tapeandreeel/>

## ELECTRICAL CHARACTERISTICS

The ● denotes the specifications which apply over the full operating temperature range, otherwise specifications are at  $T_A = 25^\circ\text{C}$ .  $V_{IN} = 12\text{V}$ ,  $\text{SHDN} = 3\text{V}$  unless otherwise noted. (Note 3)

PARAMETER	CONDITIONS	MIN	TYP	MAX	UNITS
<b>Voltage Supplies and Regulators</b>					
$V_{IN}$ Operating Voltage Range	$\text{EXTV}_{CC} = 0\text{V}$	● 5.5		80	V
	$\text{EXTV}_{CC} = 7.5\text{V}$	● 2.8		80	V
$V_{IN}$ Quiescent Current	Not Switching, $V_{\text{EXTV}_{CC}} = 0$		2.65	4.2	mA
$V_{IN}$ Quiescent Current in Shutdown	$V_{\text{SHDN}} = 0\text{V}$		0	1	μA
$\text{EXTV}_{CC}$ Switchover Voltage	$I_{\text{INTV}_{CC}} = 20\text{mA}$ , $V_{\text{EXTV}_{CC}}$ Rising	● 6.15	6.4	6.6	V
$\text{EXTV}_{CC}$ Switchover Hysteresis			0.18		V
$\text{INTV}_{CC}$ Current Limit	Maximum Current Draw from $\text{INTV}_{CC}$ and LDO33 Pins Combined. Regulated from $V_{IN}$ or $\text{EXTV}_{CC}$ (12V) $\text{INTV}_{CC} = 5.25\text{V}$ $\text{INTV}_{CC} = 4.5\text{V}$	● 90	127	165	mA
		● 28	42	55	mA
$\text{INTV}_{CC}$ Voltage	Regulated from $V_{IN}$ , $I_{\text{INTV}_{CC}} = 20\text{mA}$	● 6.15	6.35	6.55	V
	Regulated from $\text{EXTV}_{CC}$ (12V), $I_{\text{INTV}_{CC}} = 20\text{mA}$	● 6.15	6.35	6.55	V
$\text{INTV}_{CC}$ Load Regulation	$I_{\text{INTV}_{CC}} = 0\text{mA}$ to $50\text{mA}$		-0.5	-1.5	%
$\text{INTV}_{CC}$ , $\text{GATEV}_{CC}$ Undervoltage Lockout	$\text{INTV}_{CC}$ Falling, $\text{GATEV}_{CC}$ Connected to $\text{INTV}_{CC}$	● 4.45	4.65	4.85	V
$\text{INTV}_{CC}$ , $\text{GATEV}_{CC}$ Undervoltage Lockout Hysteresis	$\text{GATEV}_{CC}$ Connected to $\text{INTV}_{CC}$		160		mV
$\text{INTV}_{CC}$ Regulator Dropout Voltage	$V_{IN} - V_{\text{INTV}_{CC}}$ , $I_{\text{INTV}_{CC}} = 20\text{mA}$		245		mV
LDO33 Pin Voltage	5mA from LDO33 Pin	● 3.23	3.295	3.35	V
LDO33 Pin Load Regulation	$I_{\text{LDO33}} = 0.1\text{mA}$ to $5\text{mA}$		-0.25	-1	%
LDO33 Pin Current Limit		● 12	17.25	22	mA
LDO33 Pin Undervoltage Lockout	LDO33 Falling	2.96	3.04	3.12	V
LDO33 Pin Undervoltage Lockout Hysteresis			35		mV
<b>Switching Regulator Control</b>					
Maximum Current Sense Threshold ( $V_{\text{CSP}} - V_{\text{CSN}}$ )	Boost Mode, Minimum M3 Switch Duty Cycle (LT8705E, LT8705I) (LT8705H, LT8705MP)	● 102	117	132	mV
		● 100	117	134	mV
Maximum Current Sense Threshold ( $V_{\text{CSN}} - V_{\text{CSP}}$ )	Buck Mode, Minimum M2 Switch Duty Cycle (LT8705E, LT8705I) (LT8705H, LT8705MP)	● 69	86	102	mV
		● 67	86	104	mV

## ELECTRICAL CHARACTERISTICS

The ● denotes the specifications which apply over the full operating temperature range, otherwise specifications are at  $T_A = 25^\circ\text{C}$ .  $V_{IN} = 12\text{V}$ ,  $\text{SHDN} = 3\text{V}$  unless otherwise noted. (Note 3)

PARAMETER	CONDITIONS	MIN	TYP	MAX	UNITS	
Gain from $V_C$ to Maximum Current Sense Voltage ( $V_{CSP} - V_{CSN}$ ) (A5 in the Block Diagram)	Boost Mode Buck Mode		150 -150		mV/V mV/V	
$\overline{\text{SHDN}}$ Input Voltage High	$\overline{\text{SHDN}}$ Rising to Enable the Device	● 1.184	1.234	1.284	V	
$\overline{\text{SHDN}}$ Input Voltage High Hysteresis			50		mV	
$\overline{\text{SHDN}}$ Input Voltage Low	Device Disabled, Low Quiescent Current (LT8705E, LT8705I) (LT8705H, LT8705MP)	● ●		0.35 0.3	V V	
$\overline{\text{SHDN}}$ Pin Bias Current	$V_{\overline{\text{SHDN}}} = 3\text{V}$ $V_{\overline{\text{SHDN}}} = 12\text{V}$		0 11	1 22	$\mu\text{A}$ $\mu\text{A}$	
SWEN Rising Threshold Voltage (Note 5)		● 1.156	1.206	1.256	V	
SWEN Threshold Voltage Hysteresis (Note 5)			22		mV	
MODE Pin Forced Continuous Mode Threshold		● 0.4			V	
MODE Pin Burst Mode Range		● 1.0		1.7	V	
MODE Pin Discontinuous Mode Threshold		●		2.3	V	
Soft-Start Charging Current	$V_{SS} = 0.5\text{V}$		13	19	$\mu\text{A}$	
Soft-Start Discharge Current	$V_{SS} = 0.5\text{V}$			9.5	$\mu\text{A}$	
<b>Voltage Regulator Loops (Refer to Block Diagram to Locate Amplifiers)</b>						
Regulation Voltage for FBOUT	$V_C = 1.2\text{V}$ (LT8705E, LT8705I) $V_C = 1.2\text{V}$ (LT8705H, LT8705MP)	● ●	1.193 1.191	1.207 1.207	1.222 1.222	V V
Regulation Voltage for FBIN	$V_C = 1.2\text{V}$ (LT8705E, LT8705I) $V_C = 1.2\text{V}$ (LT8705H, LT8705MP)	● ●	1.184 1.182	1.205 1.205	1.226 1.226	V V
Line Regulation for FBOUT and FBIN Error Amp Reference Voltage	$V_{IN} = 12\text{V}$ to $80\text{V}$ ; Not Switching			0.002	0.005	%/V
FBOUT Pin Bias Current	Current Out of Pin			15	nA	
FBOUT Error Amp EA4 $g_m$				315	$\mu\text{mho}$	
FBOUT Error Amp EA4 Voltage Gain				220	V/V	
FBIN Pin Bias Current	Current Out of Pin			10	nA	
FBIN Error Amp EA3 $g_m$				130	$\mu\text{mho}$	
FBIN Error Amp EA3 Voltage Gain				90	V/V	
SRVO_FBIN Activation Threshold (Note 5)	( $V_{\text{FBIN}}$ Falling) – (Regulation Voltage for FBIN), $V_{\text{FBOUT}} = V_{\text{IMON\_IN}} = V_{\text{IMON\_OUT}} = 0\text{V}$		56	72	89	mV
SRVO_FBIN Activation Threshold Hysteresis (Note 5)	$V_{\text{FBOUT}} = V_{\text{IMON\_IN}} = V_{\text{IMON\_OUT}} = 0\text{V}$			33		mV
SRVO_FBOUT Activation Threshold (Note 5)	( $V_{\text{FBOUT}}$ Rising) – (Regulation Voltage for FBOUT), $V_{\text{FBIN}} = 3\text{V}$ , $V_{\text{IMON\_IN}} = V_{\text{IMON\_OUT}} = 0\text{V}$		-37	-29	-21	mV
SRVO_FBOUT Activation Threshold Hysteresis (Note 5)	$V_{\text{FBIN}} = 3\text{V}$ , $V_{\text{IMON\_IN}} = 0\text{V}$ , $V_{\text{IMON\_OUT}} = 0\text{V}$			15		mV
SRVO_FBIN, SRVO_FBOUT Low Voltage (Note 5)	$I = 100\mu\text{A}$	●		110	330	mV
SRVO_FBIN, SRVO_FBOUT Leakage Current (Note 5)	$V_{\text{SRVO\_FBIN}} = V_{\text{SRVO\_FBOUT}} = 2.5\text{V}$	●		0	1	$\mu\text{A}$
<b>Current Regulation Loops (Refer to Block Diagram to Locate Amplifiers)</b>						
Regulation Voltages for IMON_IN and IMON_OUT	$V_C = 1.2\text{V}$	●	1.187	1.208	1.229	V
Line Regulation for IMON_IN and IMON_OUT Error Amp Reference Voltage	$V_{IN} = 12\text{V}$ to $80\text{V}$ ; Not Switching			0.002	0.005	%/V
CSPIN, CSNIN Bias Current	BOOST Capacitor Charge Control Block Not Active $I_{\text{CSPIN}} + I_{\text{CSNIN}}$ , $V_{\text{CSPIN}} = V_{\text{CSNIN}} = 12\text{V}$			31		$\mu\text{A}$

**ELECTRICAL CHARACTERISTICS** The ● denotes the specifications which apply over the full operating temperature range, otherwise specifications are at T<sub>A</sub> = 25°C. V<sub>IN</sub> = 12V, SHDN = 3V unless otherwise noted. (Note 2)

PARAMETER	CONDITIONS	MIN	TYP	MAX	UNITS	
CSPIN, CSNIN Common Mode Operating Voltage Range	●	1.5		80	V	
CSPIN, CSNIN Differential Operating Voltage Range	●	-100		100	mV	
V <sub>CSPIN-CSNIN</sub> to IMON_IN Amplifier A7 g <sub>m</sub>	V <sub>CSPIN</sub> - V <sub>CSNIN</sub> = 50mV, V <sub>CSPIN</sub> = 5.025V (All Grades) (LT8705E, LT8705I) (LT8705H, LT8705MP)	● ● ●	0.95 0.94 0.93	1 1 1	1.05 1.06 1.07	mmho mmho mmho
IMON_IN Maximum Output Current	●	100			μA	
IMON_IN Overvoltage Threshold	●	1.55	1.61	1.67	V	
IMON_IN Error Amp EA2 g <sub>m</sub>			185		μmho	
IMON_IN Error Amp EA2 Voltage Gain			130		V/V	
CSPOUT, CSNOUT Bias Current	BOOST Capacitor Charge Control Block Not Active I <sub>CSPOUT</sub> + I <sub>CSNOUT</sub> , V <sub>CSPOUT</sub> = V <sub>CSNOUT</sub> = 12V I <sub>CSPOUT</sub> + I <sub>CSNOUT</sub> , V <sub>CSPOUT</sub> = V <sub>CSNOUT</sub> = 1.5V		45 4		μA μA	
CSPOUT, CSNOUT Common Mode Operating Voltage Range	●	0		80	V	
CSPOUT, CSNOUT Differential Mode Operating Voltage Range	●	-100		100	mV	
V <sub>CSPOUT-CSNOUT</sub> to IMON_OUT Amplifier A6 g <sub>m</sub>	V <sub>CSPOUT</sub> - V <sub>CSNOUT</sub> = 50mV, V <sub>CSPOUT</sub> = 5.025V (All Grades) (LT8705E, LT8705I) (LT8705H, LT8705MP) V <sub>CSPOUT</sub> - V <sub>CSNOUT</sub> = 5mV, V <sub>CSPOUT</sub> = 5.0025V (All Grades) (LT8705E, LT8705I) (LT8705H, LT8705MP)	● ● ● ● ●	0.95 0.94 0.93 0.65 0.55 0.5	1 1 1 1 1 1	1.05 1.085 1.095 1.35 1.6 1.65	mmho mmho mmho mmho mmho mmho
IMON_OUT Maximum Output Current	●	100			μA	
IMON_OUT Overvoltage Threshold	●	1.55	1.61	1.67	V	
IMON_OUT Error Amp EA1 g <sub>m</sub>			185		μmho	
IMON_OUT Error Amp EA1 Voltage Gain			130		V/V	
SRVO_IIN Activation Threshold (Note 5)	(V <sub>IMON_IN</sub> Rising) - (Regulation Voltage for IMON_IN), V <sub>FBIN</sub> = 3V, V <sub>FBOUT</sub> = 0V, V <sub>IMON_OUT</sub> = 0V	-60	-49	-37	mV	
SRVO_IIN Activation Threshold Hysteresis (Note 5)	V <sub>FBIN</sub> = 3V, V <sub>FBOUT</sub> = 0V, V <sub>IMON_OUT</sub> = 0V		22		mV	
SRVO_IOUT Activation Threshold (Note 5)	(V <sub>IMON_OUT</sub> Rising) - (Regulation Voltage for IMON_OUT), V <sub>FBIN</sub> = 3V, V <sub>FBOUT</sub> = 0V, V <sub>IMON_IN</sub> = 0V	-62	-51	-39	mV	
SRVO_IOUT Activation Threshold Hysteresis (Note 5)	V <sub>FBIN</sub> = 3V, V <sub>FBOUT</sub> = 0V, V <sub>IMON_IN</sub> = 0V		22		mV	
SRVO_IIN, SRVO_IOUT Low Voltage (Note 5)	I = 100μA	●	110	330	mV	
SRVO_IIN, SRVO_IOUT Leakage Current (Note 5)	V <sub>SRVO_IIN</sub> = V <sub>SRVO_IOUT</sub> = 2.5V	●	0	1	μA	

**NMOS Gate Drivers**

TG1, TG2 Rise Time	C <sub>LOAD</sub> = 3300pF (Note 4)		20		ns
TG1, TG2 Fall Time	C <sub>LOAD</sub> = 3300pF (Note 4)		20		ns
BG1, BG2 Rise Time	C <sub>LOAD</sub> = 3300pF (Note 4)		20		ns
BG1, BG2 Fall Time	C <sub>LOAD</sub> = 3300pF (Note 4)		20		ns
TG1 Off to BG1 On Delay	C <sub>LOAD</sub> = 3300pF Each Driver		100		ns
BG1 Off to TG1 On Delay	C <sub>LOAD</sub> = 3300pF Each Driver		80		ns
TG2 Off to BG2 On Delay	C <sub>LOAD</sub> = 3300pF Each Driver		100		ns

## ELECTRICAL CHARACTERISTICS

The ● denotes the specifications which apply over the full operating temperature range, otherwise specifications are at  $T_A = 25^\circ\text{C}$ .  $V_{IN} = 12\text{V}$ ,  $\text{SHDN} = 3\text{V}$  unless otherwise noted. (Note 3)

PARAMETER	CONDITIONS	MIN	TYP	MAX	UNITS	
BG2 Off to TG2 On Delay	$C_{LOAD} = 3300\text{pF}$ Each Driver		80		ns	
Minimum On-Time for Main Switch in Boost Operation ( $t_{ON(M3,MIN)}$ )	Switch M3, $C_{LOAD} = 3300\text{pF}$		265		ns	
Minimum On-Time for Synchronous Switch in Buck Operation ( $t_{ON(M2,MIN)}$ )	Switch M2, $C_{LOAD} = 3300\text{pF}$		260		ns	
Minimum Off-Time for Main Switch in Steady-State Boost Operation	Switch M3, $C_{LOAD} = 3300\text{pF}$		245		ns	
Minimum Off-Time for Synchronous Switch in Steady-State Buck Operation	Switch M2, $C_{LOAD} = 3300\text{pF}$		245		ns	
<b>Oscillator</b>						
Switch Frequency Range	SYNCing or Free Running		100	400	kHz	
Switching Frequency, $f_{OSC}$	$R_T = 365\text{k}$	●	102	120	142	kHz
	$R_T = 215\text{k}$	●	170	202	235	kHz
	$R_T = 124\text{k}$	●	310	350	400	kHz
SYNC High Level for Synchronization		●	1.3		V	
SYNC Low Level for Synchronization		●		0.5	V	
SYNC Clock Pulse Duty Cycle	$V_{SYNC} = 0\text{V}$ to $2\text{V}$		20	80	%	
Recommended Minimum SYNC Ratio $f_{SYNC}/f_{OSC}$			3/4			
CLKOUT Output Voltage High	1mA Out of CLKOUT Pin		2.3	2.45	2.55	V
CLKOUT Output Voltage Low	1mA Into CLKOUT Pin			25	100	mV
CLKOUT Duty Cycle	$T_J = -40^\circ\text{C}$			22.7		%
	$T_J = 25^\circ\text{C}$			44.1		%
	$T_J = 125^\circ\text{C}$			77		%
CLKOUT Rise Time	$C_{LOAD} = 200\text{pF}$			30		ns
CLKOUT Fall Time	$C_{LOAD} = 200\text{pF}$			25		ns
CLKOUT Phase Delay	SYNC Rising to CLKOUT Rising, $f_{OSC} = 100\text{kHz}$	●	160	180	200	Deg

**Note 1:** Stresses beyond those listed under Absolute Maximum Ratings may cause permanent damage to the device. Exposure to any Absolute Maximum Rating condition for extended periods may affect device reliability and lifetime.

**Note 2:** Do not force voltage on the  $V_C$  pin.

**Note 3:** The LT8705E is guaranteed to meet performance specifications from  $0^\circ\text{C}$  to  $125^\circ\text{C}$  junction temperature. Specifications over the  $-40^\circ\text{C}$  to  $125^\circ\text{C}$  operating junction temperature range are assured by design, characterization and correlation with statistical process controls. The LT8705I is guaranteed over the full  $-40^\circ\text{C}$  to  $125^\circ\text{C}$  junction temperature range. The LT8705H is guaranteed over the full  $-40^\circ\text{C}$  to  $150^\circ\text{C}$  operating junction temperature range. The LT8705MP is guaranteed over the full  $-55^\circ\text{C}$  to  $150^\circ\text{C}$  operating junction temperature range. Operating lifetime is derated at junction temperatures greater than  $125^\circ\text{C}$ .

**Note 4:** Rise and fall times are measured using 10% and 90% levels. Delay times are measured using 50% levels.

**Note 5:** This specification not applicable in the FE38 package.

**Note 6:** Do not apply a voltage or current source to these pins. They must be connected to capacitive loads only, otherwise permanent damage may occur.

**Note 7:** Negative voltages on the SW1 and SW2 pins are limited, in an application, by the body diodes of the external NMOS devices, M2 and M3, or parallel Schottky diodes when present. The SW1 and SW2 pins are tolerant of these negative voltages in excess of one diode drop below ground, guaranteed by design.

**Note 8:** This IC includes overtemperature protection that is intended to protect the device during momentary overload conditions. Junction temperature will exceed the maximum operating junction temperature when overtemperature protection is active. Continuous operation above the specified maximum operating junction temperature may impair device reliability.

**TYPICAL PERFORMANCE CHARACTERISTICS**  $T_A = 25^\circ\text{C}$  unless otherwise specified.

**Efficiency vs Output Current (Boost Region-Figure 14)**

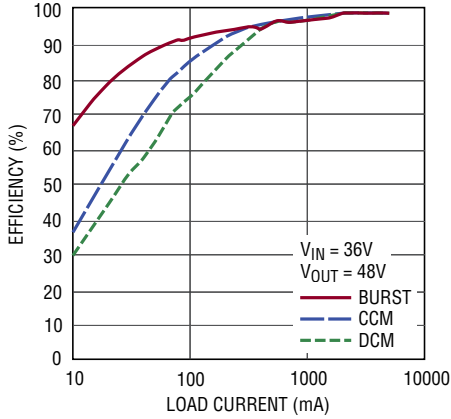

8705 G01

**Efficiency vs Output Current (Buck-Boost Region-Figure 14)**

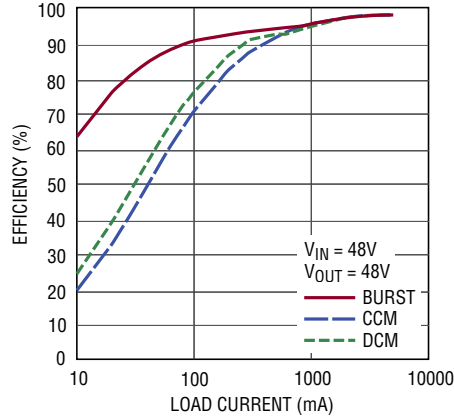

8705 G02

**Efficiency vs Output Current (Buck Region-Figure 14)**

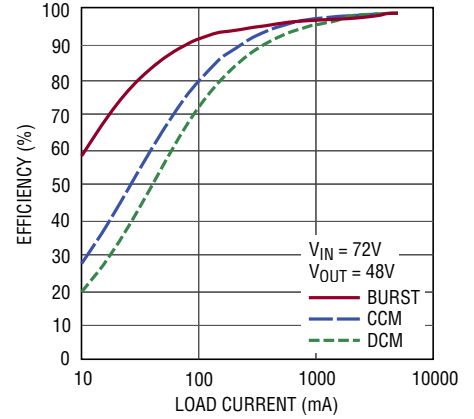

8705 G03

**Feedback Voltages**

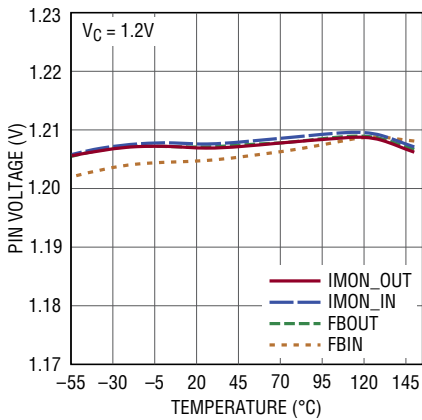

8705 G04

**FBOUT Voltages (Five Parts)**

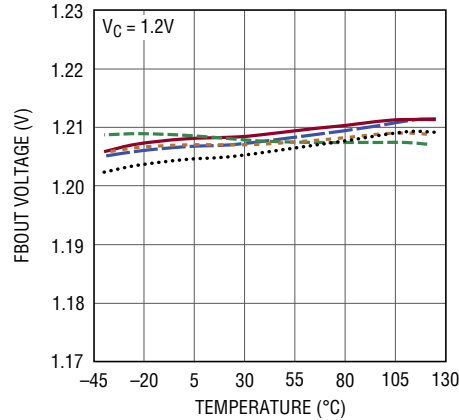

8795 G05

**Oscillator Frequency**

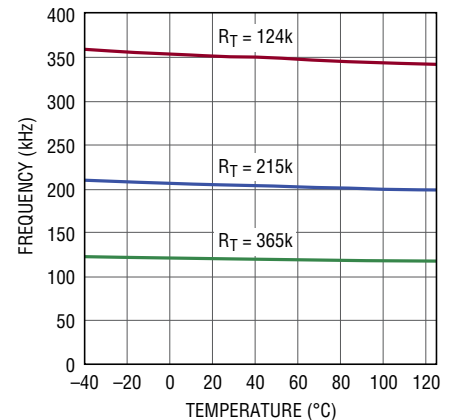

8705 G06

**Maximum Inductor Current Sense Voltage vs Duty Cycle**

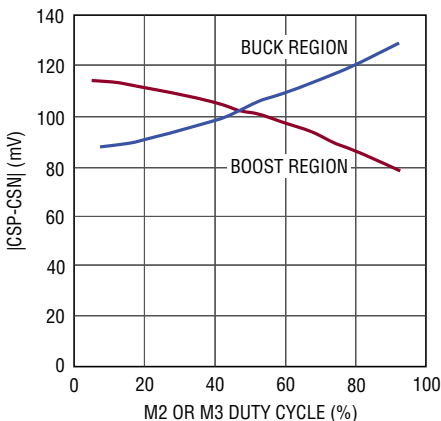

8705 G07

**Inductor Current Sense Voltage at Minimum Duty Cycle**

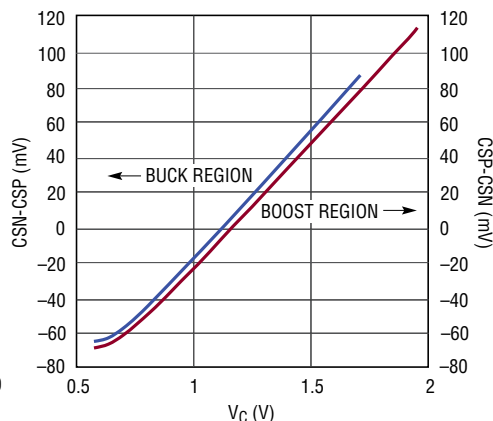

8705 G08

**Maximum Inductor Current Sense Voltage at Minimum Duty Cycle**

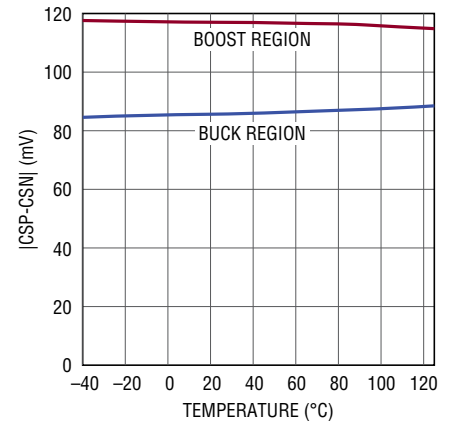

8705 G09

## TYPICAL PERFORMANCE CHARACTERISTICS $T_A = 25^\circ\text{C}$ unless otherwise specified.

**Minimum Inductor Current Sense Voltage in Forced Continuous Mode**

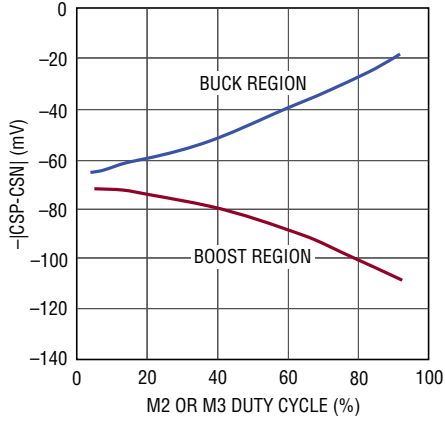

8705 G10

**INTV<sub>CC</sub> Line Regulation (EXTV<sub>CC</sub> = 0V)**

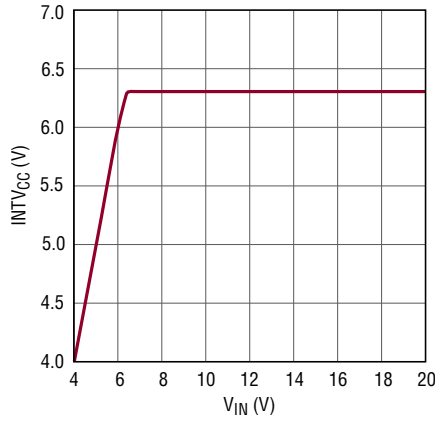

8705 G11

**INTV<sub>CC</sub> Line Regulation (V<sub>IN</sub> = 12V)**

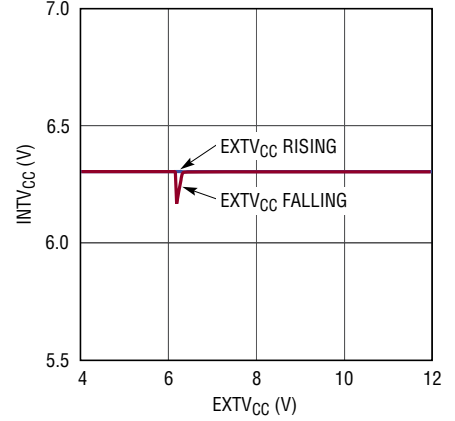

8705 G12

**Maximum V<sub>C</sub> vs SS**

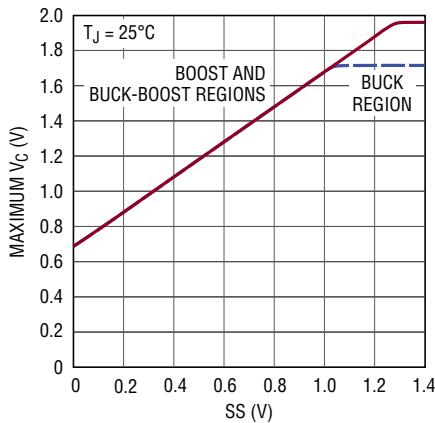

8705 G13

**V<sub>IN</sub> Supply Current vs Voltage (Not Switching)**

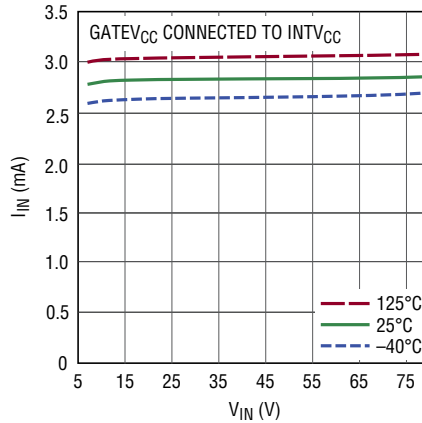

8705 G14

**IMON Output Currents**

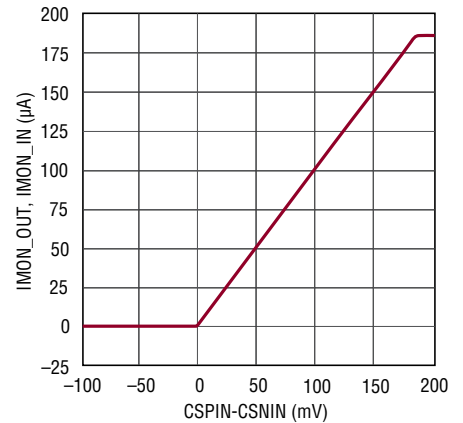

8705 G15

**CLKOUT Duty Cycle**

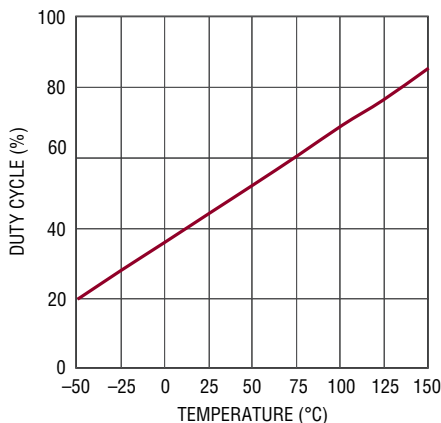

8705 G16

**LDO33 Pin Regulation (I<sub>LDO33</sub> = 1mA)**

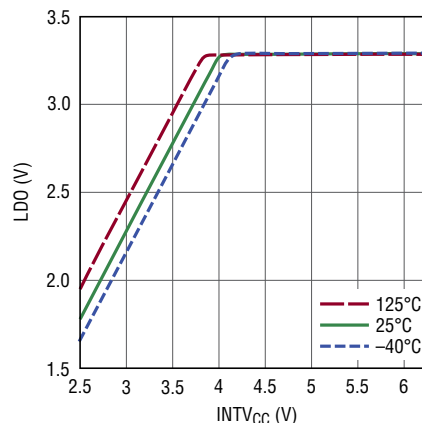

8705 G17

**SHDN and SWEN Pin Thresholds vs Temperature**

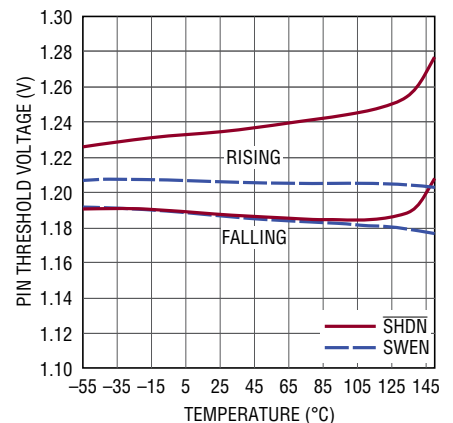

8705 G18

**TYPICAL PERFORMANCE CHARACTERISTICS**  $T_A = 25^\circ\text{C}$  unless otherwise specified.

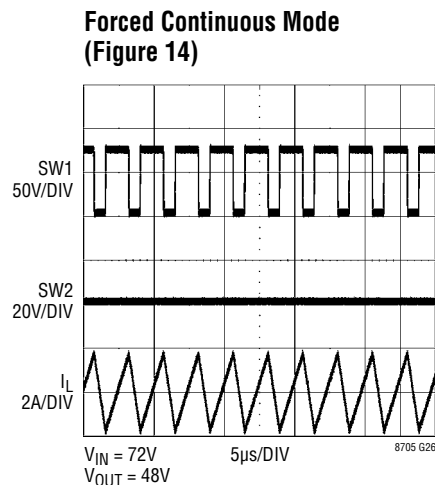
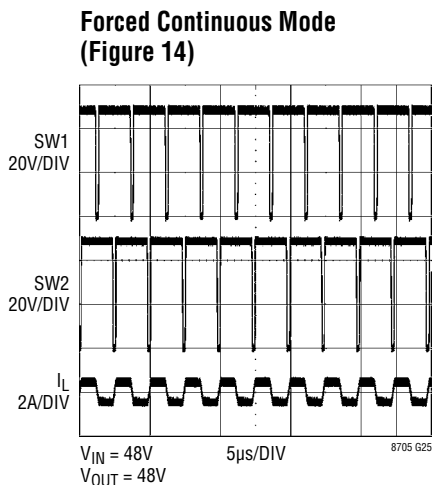
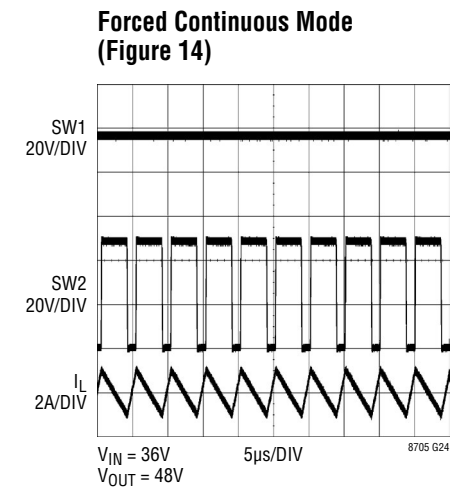
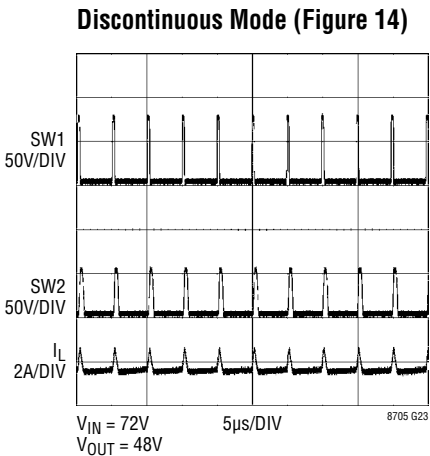
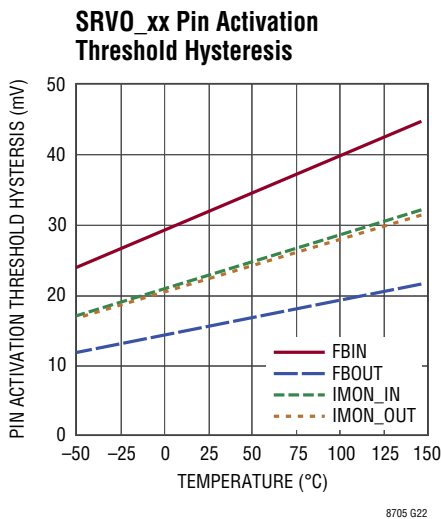
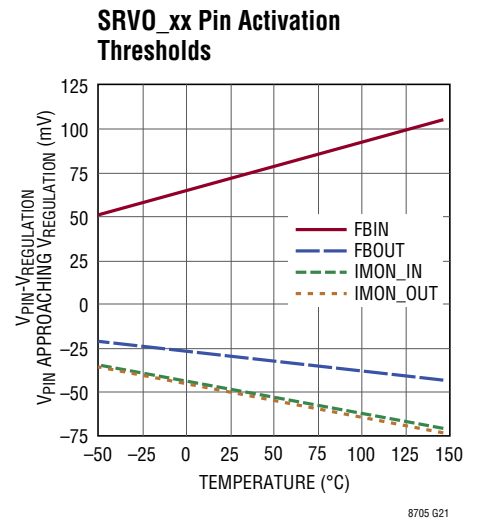
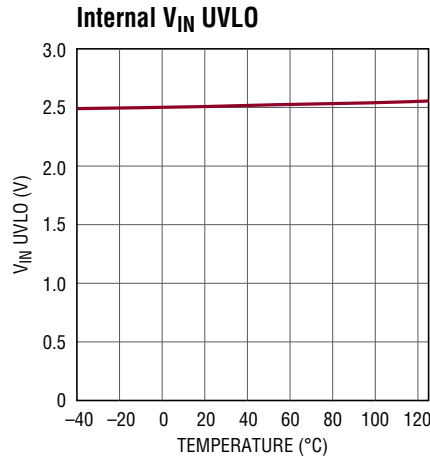
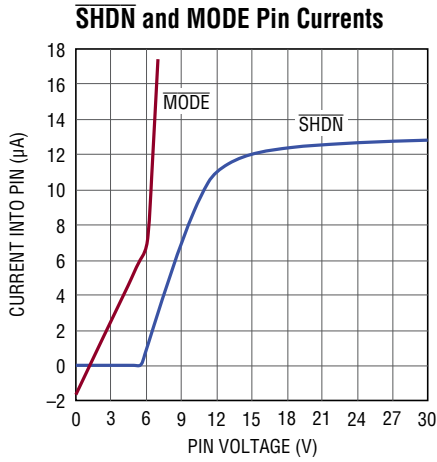

**TYPICAL PERFORMANCE CHARACTERISTICS**  $T_A = 25^\circ\text{C}$  unless otherwise specified.

**Burst Mode Operation (Figure 14)**

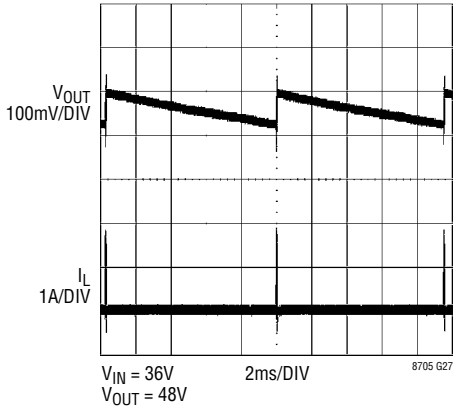

**Burst Mode Operation (Figure 14)**

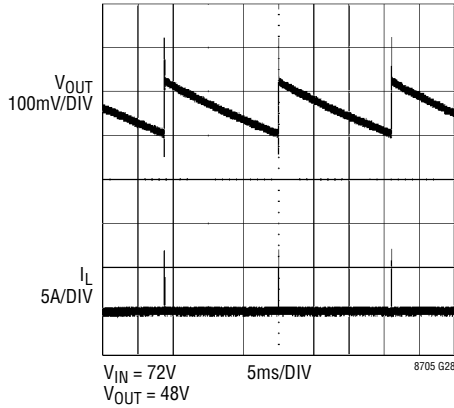

**Load Step (Figure 14)**

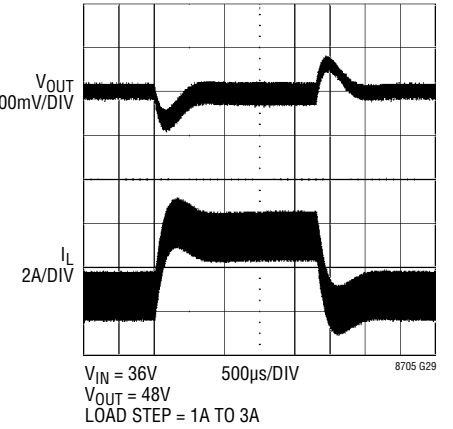

**Load Step (Figure 14)**

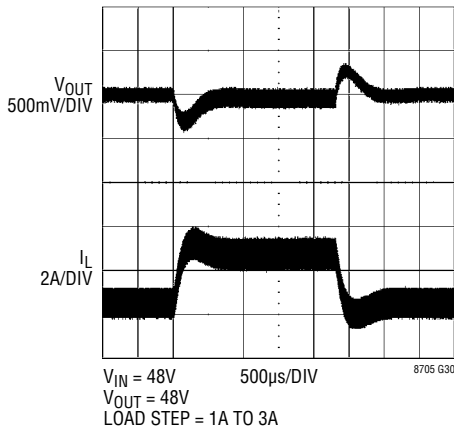

**Load Step (Figure 14)**

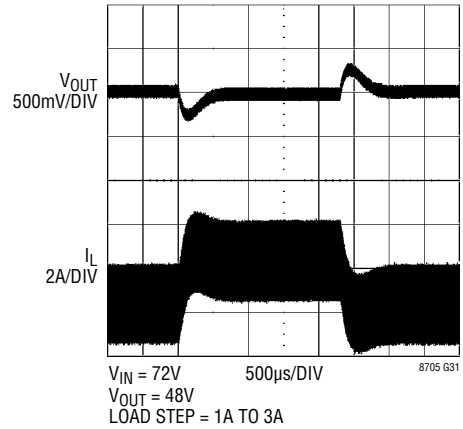

**Line Transient (Figure 14)**

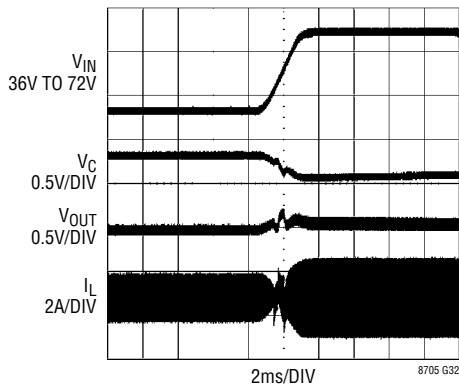

**Line Transient (Figure 14)**

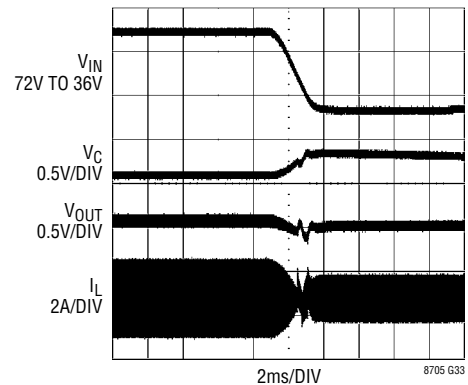

## PIN FUNCTIONS (QFN/TSSOP)

**SHDN (Pin 1/Pin 4):** Shutdown Pin. Tie high to enable device. Ground to shut down and reduce quiescent current to a minimum. Do not float this pin.

**CSN (Pin 2/Pin 5):** The (–) Input to the Inductor Current Sense and Reverse-Current Detect Amplifier.

**CSP (Pin 3/Pin 6):** The (+) Input to the Inductor Current Sense and Reverse-Current Detect Amplifier. The  $V_C$  pin voltage and built-in offsets between CSP and CSN pins, in conjunction with the  $R_{SENSE}$  resistor value, set the current trip threshold.

**LD033 (Pin 4/Pin 7):** 3.3V Regulator Output. Bypass this pin to ground with a minimum 0.1 $\mu$ F ceramic capacitor.

**FBIN (Pin 5/Pin 8):** Input Feedback Pin. This pin is connected to the input error amplifier input.

**FBOUT (Pin 6/Pin 9):** Output Feedback Pin. This pin connects the error amplifier input to an external resistor divider from the output.

**IMON\_OUT (Pin 7/Pin 10):** Output Current Monitor Pin. The current out of this pin is proportional to the output current. See the Operation and Applications Information sections.

**$V_C$  (Pin 8/Pin 11):** Error Amplifier Output Pin. Tie external compensation network to this pin.

**SS (Pin 9/Pin 12):** Soft-Start Pin. Place at least 100nF of capacitance here. Upon start-up, this pin will be charged by an internal resistor to 2.5V.

**CLKOUT (Pin 10/Pin 13):** Clock Output Pin. Use this pin to synchronize one or more compatible switching regulator ICs to the LT8705. CLKOUT toggles at the same frequency as the internal oscillator or as the SYNC pin, but is approximately 180° out of phase. CLKOUT may also be used as a temperature monitor since the CLKOUT duty cycle varies linearly with the part's junction temperature. The CLKOUT pin can drive capacitive loads up to 200pF.

**SYNC (Pin 11/Pin 14):** To synchronize the switching frequency to an outside clock, simply drive this pin with a clock. The high voltage level of the clock needs to exceed 1.3V, and the low level should be less than 0.5V. Drive this pin to less than 0.5V to revert to the internal free-running clock. See the Applications Information section for more information.

**RT (Pin 12/Pin 15):** Timing Resistor Pin. Adjusts the switching frequency. Place a resistor from this pin to ground to set the free-running frequency. Do not float this pin.

**BG1, BG2 (Pins 14, 16/Pins 17, 19):** Bottom Gate Drive. Drives the gates of the bottom N-channel MOSFETs between ground and  $GATEV_{CC}$ .

**$GATEV_{CC}$  (Pin 15/Pin 18):** Power Supply for Gate Drivers. Must be connected to the  $INTV_{CC}$  pin. Do not power from any other supply. Locally bypass to GND.

**BOOST1, BOOST2 (Pins 23, 17/Pins 28, 20):** Boosted Floating Driver Supply. The (+) terminal of the bootstrap capacitor connects here. The BOOST1 pin swings from a diode voltage below  $GATEV_{CC}$  up to  $V_{IN} + GATEV_{CC}$ . The BOOST2 pin swings from a diode voltage below  $GATEV_{CC}$  up to  $V_{OUT} + GATEV_{CC}$ .

**TG1, TG2 (Pins 22, 18/Pins 26, 21):** Top Gate Drive. Drives the top N-channel MOSFETs with voltage swings equal to  $GATEV_{CC}$  superimposed on the switch node voltages.

**SW1, SW2 (Pins 21, 19/Pins 24, 22):** Switch Nodes. The (–) terminals of the bootstrap capacitors connect here.

**SRVO\_FBIN (Pin 25 QFN Only):** Open-Drain Logic Output. This pin is pulled to ground when the input voltage feedback loop is active.

**SRVO\_IIN (Pin 26 QFN Only):** Open-Drain Logic Output. The pin is pulled to ground when the input current loop is active.

**SRVO\_IOUT (Pin 27 QFN Only):** Open-Drain Logic Output. The pin is pulled to ground when the output current feedback loop is active.

**SRVO\_FBOUT (Pin 28 QFN Only):** Open-Drain Logic Output. This pin is pulled to ground when the output voltage feedback loop is active.

**$EXTV_{CC}$  (Pin 29/Pin 30):** External  $V_{CC}$  Input. When  $EXTV_{CC}$  exceeds 6.4V (typical),  $INTV_{CC}$  will be powered from this pin. When  $EXTV_{CC}$  is lower than 6.22V (typical),  $INTV_{CC}$  will be powered from  $V_{IN}$ .

**CSNOUT (Pin 30/Pin 32):** The (–) Input to the Output Current Monitor Amplifier. Connect this pin to  $V_{OUT}$  when not in use. See Applications Information section for proper use of this pin.

## PIN FUNCTIONS (QFN/TSSOP)

**CSPOUT (Pin 31/Pin 34):** The (+) Input to the Output Current Monitor Amplifier. This pin and the CSNOUT pin measure the voltage across the sense resistor,  $R_{SENSE2}$ , to provide the output current signals. Connect this pin to  $V_{OUT}$  when not in use. See Applications Information section for proper use of this pin.

**CSNIN (Pin 32/Pin 36):** The (–) Input to the Input Current Monitor Amplifier. This pin and the CSPIN pin measure the voltage across the sense resistor,  $R_{SENSE1}$ , to provide the input current signals. Connect this pin to  $V_{IN}$  when not in use. See Applications Information section for proper use of this pin.

**CSPIN (Pin 33/Pin 37):** The (+) Input to the Input Current Monitor Amplifier. Connect this pin to  $V_{IN}$  when not in use. See Applications Information section for proper use of this pin.

**$V_{IN}$  (Pin 34/Pin 38):** Main Input Supply Pin. It must be locally bypassed to ground.

**INTV<sub>CC</sub> (Pin 35/Pin 1):** Internal 6.35V Regulator Output. Must be connected to the GATEV<sub>CC</sub> pin. INTV<sub>CC</sub> is powered from EXT<sub>V</sub><sub>CC</sub> when the EXT<sub>V</sub><sub>CC</sub> voltage is higher than 6.4V, otherwise INTV<sub>CC</sub> is powered from  $V_{IN}$ . Bypass this pin to ground with a minimum 4.7 $\mu$ F ceramic capacitor.

**SWEN (Pin 36 QFN Only):** Switch Enable Pin. Tie high to enable switching. Ground to disable switching. Don't float this pin. This pin is internally tied to INTV<sub>CC</sub> in the TSSOP package.

**IMON\_IN (Pin 38/Pin 3):** Input Current Monitor Pin. The current out of this pin is proportional to the input current. See the Operation and Applications Information sections.

**MODE (Pin 37/Pin 2):** Mode Pin. The voltage applied to this pin sets the operating mode of the controller. When the applied voltage is less than 0.4V, the forced continuous current mode is active. When this pin is allowed to float, Burst Mode operation is active. When the MODE pin voltage is higher than 2.3V, discontinuous mode is active.

**GND (Pin 13, Exposed Pad Pin 39/Pin 16, Exposed Pad Pin 39):** Ground. Tie directly to local ground plane.

# BLOCK DIAGRAM

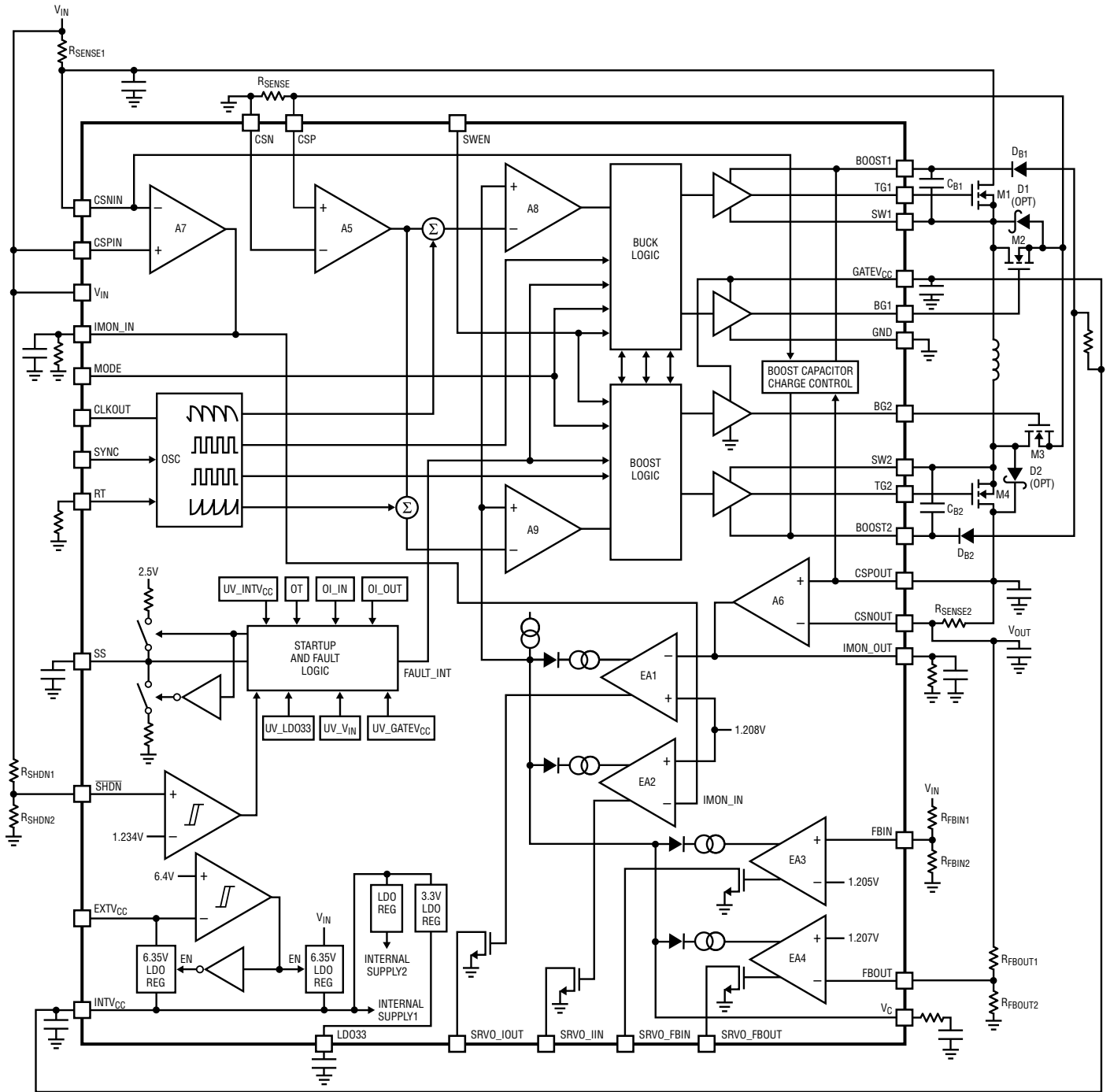

Figure 1. Block Diagram

## OPERATION

Refer to the Block Diagram (Figure 1) when reading the following sections about the operation of the LT8705.

### Main Control Loop

The LT8705 is a current mode controller that provides an output voltage above, equal to or below the input voltage. The LTC proprietary topology and control architecture employs a current-sensing resistor ( $R_{SENSE}$ ) in buck or boost modes. The inductor current is controlled by the voltage on the  $V_C$  pin, which is the diode-AND of error amplifiers EA1-EA4. In the simplest form, where the output is regulated to a constant voltage, the FBOUT pin receives the output voltage feedback signal, which is compared to the internal reference voltage by EA4. Low output voltages would create a higher  $V_C$  voltage, and thus more current would flow into the output. Conversely, higher output voltages would cause  $V_C$  to drop, thus reducing the current fed into the output.

The LT8705 contains four error amplifiers (EA1-EA4) allowing it to regulate or limit the output current (EA1), input current (EA2), input voltage (EA3) and/or output voltage (EA4). In a typical application, the output voltage might be regulated using EA4, while the remaining error amplifiers are monitoring for excessive input or output current or an input undervoltage condition. In other applications, such as a battery charger, the output current regulator (EA1) can facilitate constant current charging until a predetermined voltage is reached where the output voltage (EA4) control would take over.

### INTV<sub>CC</sub>/EXTV<sub>CC</sub>/GATEV<sub>CC</sub>/LDO33 Power

Power for the top and bottom MOSFET drivers, the LDO33 pin and most internal circuitry is derived from the INTV<sub>CC</sub> pin. INTV<sub>CC</sub> is regulated to 6.35V (typical) from either the  $V_{IN}$  or EXTV<sub>CC</sub> pin. When the EXTV<sub>CC</sub> pin is left open or tied to a voltage less than 6.22V (typical), an internal low dropout regulator regulates INTV<sub>CC</sub> from  $V_{IN}$ . If EXTV<sub>CC</sub> is taken above 6.4V (typical), another low dropout regulator will instead regulate INTV<sub>CC</sub> from EXTV<sub>CC</sub>. Regulating INTV<sub>CC</sub> from EXTV<sub>CC</sub> allows the power to be derived from the lowest supply voltage (highest efficiency) such as the LT8705 switching regulator output (see INTV<sub>CC</sub> Regulators and EXTV<sub>CC</sub> Connection in the Applications Information section for more details).

The GATEV<sub>CC</sub> pin directly powers the bottom MOSFET drivers for switches M2 and M3. GATEV<sub>CC</sub> should always be connected to INTV<sub>CC</sub> and should not be powered or connected to any other source. Undervoltage lock outs (UVLOs) monitoring INTV<sub>CC</sub> and GATEV<sub>CC</sub> disable the switching regulator when the pins are below 4.65V (typical).

The LDO33 pin is available to provide power to external components such as a microcontroller and/or to provide an accurate bias voltage. Load current is limited to 17.25mA (typical). As long as  $\overline{SHDN}$  is high the LDO33 output is linearly regulated from the INTV<sub>CC</sub> pin and is not affected by the INTV<sub>CC</sub> or GATEV<sub>CC</sub> UVLOs or the SWEN pin voltage. LDO33 will remain regulated as long as  $\overline{SHDN}$  is high and sufficient voltage is available on INTV<sub>CC</sub> (typically > 4.0V). An undervoltage lockout, monitoring LDO33, will disable the switching regulator when LDO33 is below 3.04V (typical).

### Start-Up

Figure 2 illustrates the start-up sequence for the LT8705. The master shutdown pin for the chip is  $\overline{SHDN}$ . When driven below 0.35V (LT8705E, LT8705I) or 0.3V (LT8705H, LT8705MP) the chip is disabled (chip off state) and quiescent current is minimal. Increasing the  $\overline{SHDN}$  voltage can increase quiescent current but will not enable the chip until  $\overline{SHDN}$  is driven above 1.234V (typical) after which the INTV<sub>CC</sub> and LDO33 regulators are enabled (switcher off state). External devices powered by the LDO33 pin can become active at this time if enough voltage is available on  $V_{IN}$  or EXTV<sub>CC</sub> to raise INTV<sub>CC</sub>, and thus LDO33, to an adequate voltage.

Starting up the switching regulator happens after SWEN (switcher enable) is also driven above 1.206V (typical), INTV<sub>CC</sub> and GATEV<sub>CC</sub> have risen above 4.81V (typical) and the LDO33 pin has risen above 3.08V (typical) (initialize state). The SWEN pin is not available in the TSSOP package. In this package the SWEN pin is internally connected to INTV<sub>CC</sub>.

### Start-Up: Soft-Start of Switch Current

In the initialize state, the SS (soft-start) pin is pulled low to prepare for soft starting the regulator. If forced continuous mode is selected (MODE pin low), the part is put into discontinuous mode during soft-start to prevent current

**OPERATION**

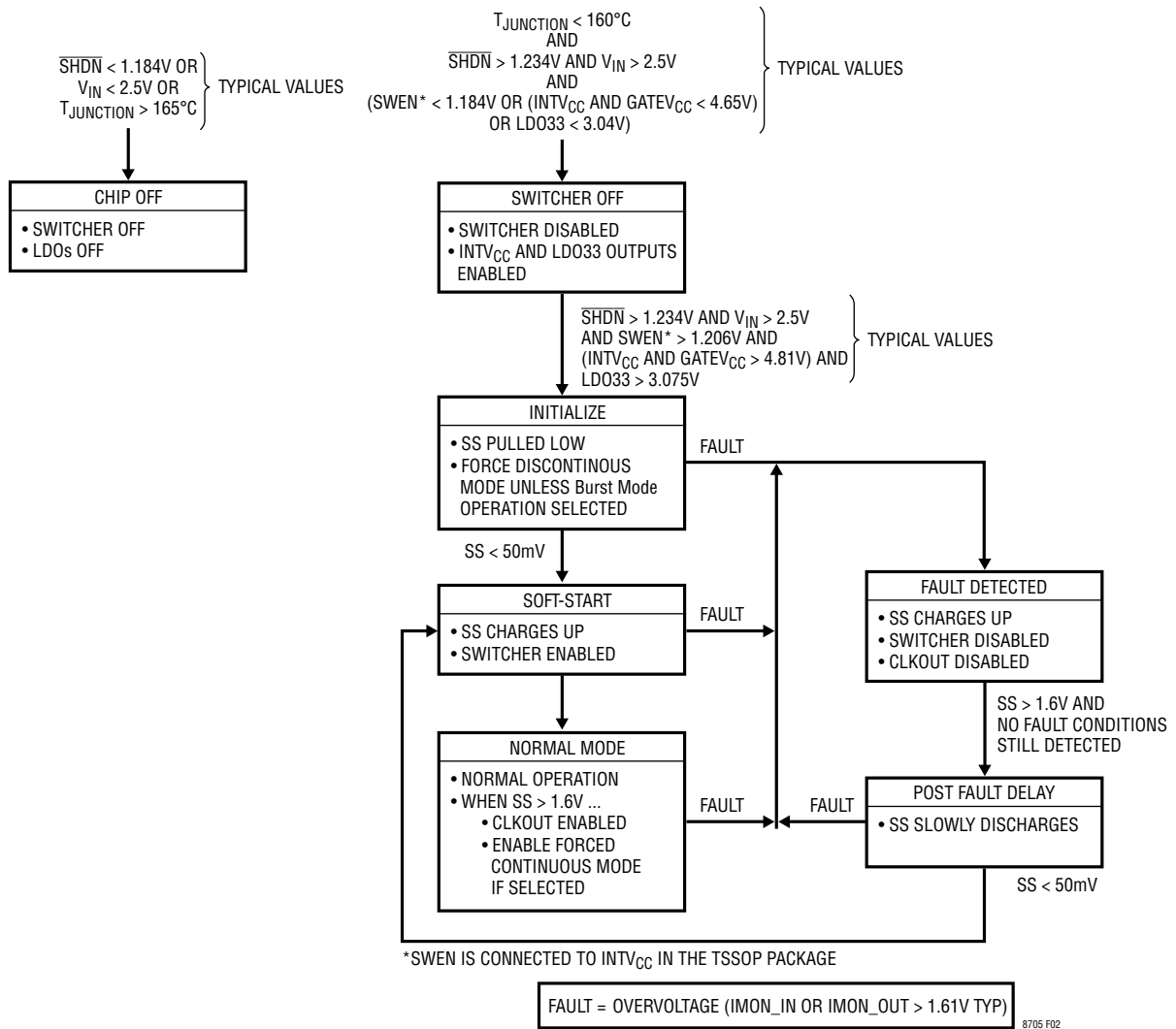

**Figure 2. Start-Up and Fault Sequence**

from being drawn out of the output and forced into the input. After SS has been discharged to less than 50mV, a soft-start of the switching regulator begins (soft-start state). The soft-start circuitry provides for a gradual ramp-up of the inductor current by gradually allowing the  $V_C$  voltage to rise (refer to  $V_C$  vs SS Voltage in the Typical Performance Characteristics). This prevents abrupt surges of current from being drawn out of the input power supply. An integrated 100k resistor pulls the SS pin to  $\approx 2.5V$ . The ramp rate of the SS pin voltage is set by this 100k resistor and the external capacitor connected to this pin. Once SS gets to 1.6V, the CLKOUT pin is enabled, the part is

allowed to enter forced continuous mode (if MODE is low) and an internal regulator pulls SS up quickly to  $\approx 2.5V$ . Typical values for the external soft-start capacitor range from 100nF to 1 $\mu$ F. A minimum of 100nF is recommended.

**Fault Conditions**

The LT8705 activates a fault sequence under certain operating conditions. If any of these conditions occur (see Figure 2) the CLKOUT pin and internal switching activity are disabled. At the same time, a timeout sequence commences where the SS pin is charged up to a minimum of 1.6V (fault detected state). The SS pin will continue

## OPERATION

charging up to 2.5V and be held there in the case of a fault event that persists. After the fault condition had ended and SS is greater than 1.6V, SS will then slowly discharge to 50mV (post fault delay state). This timeout period relieves the part and other downstream power components from electrical and thermal stress for a minimum amount of time as set by the voltage ramp rate on the SS pin. After SS has discharged to < 50mV, the LT8705 will enter the soft-start state and restart switching activity.

### Power Switch Control

Figure 3 shows a simplified diagram of how the four power switches are connected to the inductor,  $V_{IN}$ ,  $V_{OUT}$  and ground. Figure 4 shows the regions of operation for the LT8705 as a function of  $V_{OUT}-V_{IN}$  or switch duty cycle DC. The power switches are properly controlled so the transfer between modes is continuous.

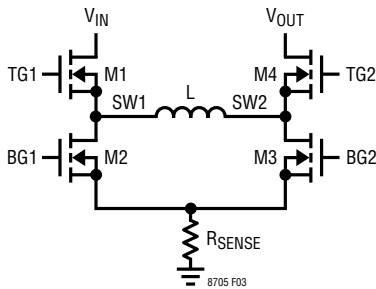

Figure 3. Simplified Diagram of the Output Switches

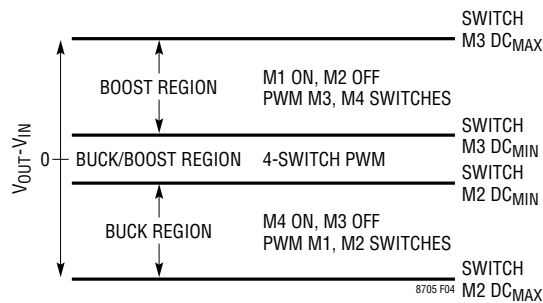

Figure 4. Operating Regions vs  $V_{OUT}-V_{IN}$

### Power Switch Control: Buck Region ( $V_{IN} \gg V_{OUT}$ )

When  $V_{IN}$  is significantly higher than  $V_{OUT}$ , the part will run in the buck region. In this region switch M3 is always off. Also, switch M4 is always on unless reverse current is detected while in Burst Mode operation or discontinuous mode. At the start of every cycle, synchronous switch M2

is turned on first. Inductor current is sensed by amplifier A5 while switch M2 is on. A slope compensation ramp is added to the sensed voltage which is then compared by A8 to a reference that is proportional to  $V_C$ . After the sensed inductor current falls below the reference, switch M2 is turned off and switch M1 is turned on for the remainder of the cycle. Switches M1 and M2 will alternate, behaving like a typical synchronous buck regulator.

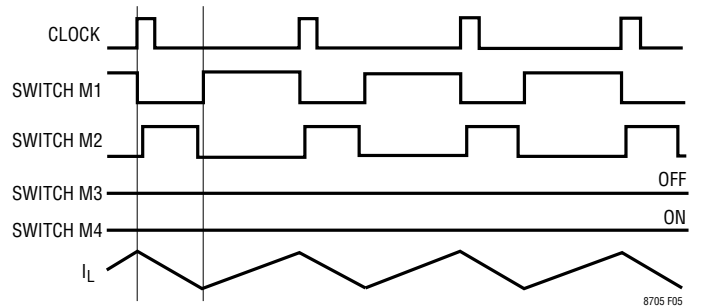

Figure 5. Buck Region ( $V_{IN} \gg V_{OUT}$ )

The part will continue operating in the buck region over a range of switch M2 duty cycles. The duty cycle of switch M2 in the buck region is given by:

$$DC_{(M2,BUCK)} = \left(1 - \frac{V_{OUT}}{V_{IN}}\right) \cdot 100\%$$

As  $V_{IN}$  and  $V_{OUT}$  get closer to each other, the duty cycle decreases until the minimum duty cycle of the converter in buck mode reaches  $DC_{(ABSMIN,M2,BUCK)}$ . If the duty cycle becomes lower than  $DC_{(ABSMIN,M2,BUCK)}$  the part will move to the buck-boost region.

$$DC_{(ABSMIN,M2,BUCK)} \cong t_{ON(M2,MIN)} \cdot f \cdot 100\%$$

where:

$t_{ON(M2,MIN)}$  is the minimum on-time for the synchronous switch in buck operation (260ns typical, see Electrical Characteristics).

$f$  is the switching frequency

When  $V_{IN}$  is much higher than  $V_{OUT}$  the duty cycle of switch M2 will increase, causing the M2 switch off-time to decrease. The M2 switch off-time should be kept above 245ns (typical, see Electrical Characteristics) to maintain steady-state operation, avoid duty cycle jitter, increased output ripple and reduction in maximum output current.

8705ff

## OPERATION

### Power Switch Control: Buck-Boost ( $V_{IN} \cong V_{OUT}$ )

When  $V_{IN}$  is close to  $V_{OUT}$ , the controller enters the buck-boost region. Figure 6 shows typical waveforms in this region. Every cycle, if the controller starts with switches M2 and M4 turned on, the controller first operates as if in the buck region. When A8 trips, switch M2 is turned off and M1 is turned on until the middle of the clock cycle. Next, switch M4 turns off and M3 turns on. The LT8705 then operates as if in boost mode until A9 trips. Finally switch M3 turns off and M4 turns on until the end of the cycle.

If the controller starts with switches M1 and M3 turned on, the controller first operates as if in the boost region. When A9 trips, switch M3 is turned off and M4 is turned on until the middle of the clock cycle. Next, switch M1 turns off and M2 turns on. The LT8705 then operates as if in buck mode until A8 trips. Finally switch M2 turns off and M1 turns on until the end of the cycle.

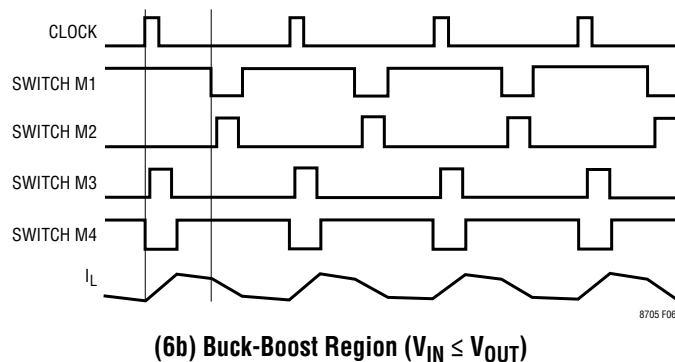
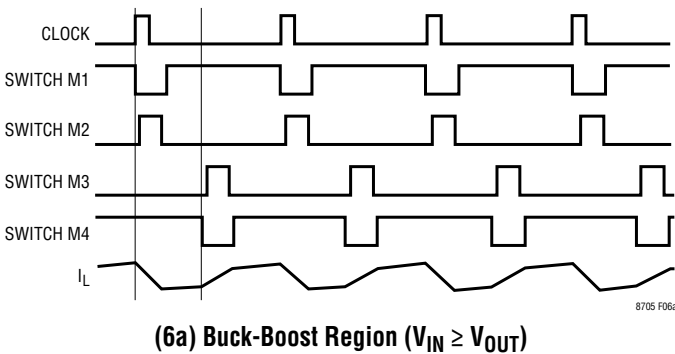

Figure 6. Buck-Boost Region

### Power Switch Control: Boost Region ( $V_{IN} \ll V_{OUT}$ )

When  $V_{OUT}$  is significantly higher than  $V_{IN}$ , the part will run in the boost region. In this region switch M1 is always on and switch M2 is always off. At the start of every cycle, switch M3 is turned on first. Inductor current is sensed by amplifier A5 while switch M3 is on. A slope compensation ramp is added to the sensed voltage which is then compared (A9) to a reference that is proportional to  $V_C$ . After the sensed inductor current rises above the reference voltage, switch M3 is turned off and switch M4 is turned on for the remainder of the cycle. Switches M3 and M4 will alternate, behaving like a typical synchronous boost regulator.

The part will continue operating in the boost region over a range of switch M3 duty cycles. The duty cycle of switch M3 in the boost region is given by:

$$DC_{(M3,BOOST)} = \left(1 - \frac{V_{IN}}{V_{OUT}}\right) \cdot 100\%$$

As  $V_{IN}$  and  $V_{OUT}$  get closer to each other, the duty cycle decreases until the minimum duty cycle of the converter in boost mode reaches  $DC_{(ABSMIN,M3,BOOST)}$ . If the duty cycle becomes lower than  $DC_{(ABSMIN,M3,BOOST)}$  the part will move to the buck-boost region:

$$DC_{(ABSMIN,M3,BOOST)} \cong t_{ON(M3,MIN)} \cdot f \cdot 100\%$$

where:

$t_{ON(M3,MIN)}$  is the minimum on-time for the main switch in boost operation (265ns typical, see Electrical Characteristics)

$f$  is the switching frequency

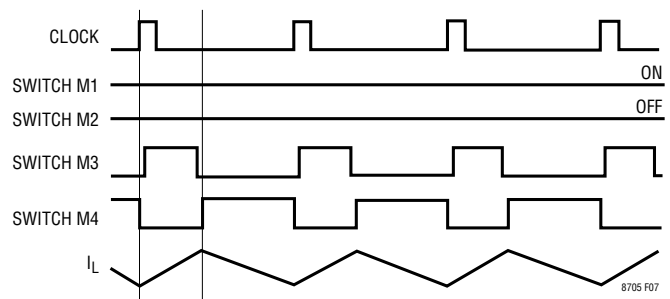

Figure 7. Boost Region ( $V_{IN} \ll V_{OUT}$ )

## OPERATION

When  $V_{OUT}$  is much higher than  $V_{IN}$  the duty cycle of switch M3 will increase, causing the M3 switch off-time to decrease. The M3 switch off-time should be kept above 245ns (typical, see Electrical Characteristics) to maintain steady-state operation, avoid duty cycle jitter, increased output ripple and reduction in maximum output current.

### Light Load Current Operation (MODE Pin)

Under light current load conditions, the LT8705 can be set to operate in discontinuous mode, forced continuous mode, or Burst Mode operation. To select forced continuous mode, tie the MODE pin to a voltage below 0.4V (i.e., ground). To select discontinuous mode, tie MODE to a voltage above 2.3V (i.e., LDO33). To select Burst Mode operation, float the MODE pin or tie it between 1.0V and 1.7V.

**Discontinuous Mode:** When the LT8705 is in discontinuous mode, synchronous switch M4 is held off whenever reverse current in the inductor is detected. This is to prevent current draw from the output and/or feeding current to the input supply. Under very light loads, the current comparator may also remain tripped for several cycles and force switches M1 and M3 to stay off for the same number of cycles (i.e., skipping pulses). Synchronous switch M2 will remain on during the skipped cycles, but since switch M4 is off, the inductor current will not reverse.

**Burst Mode Operation:** Burst Mode operation sets a  $V_C$  level, with about 25mV of hysteresis, below which switching activity is inhibited and above which switching activity is re-enabled. A typical example is when, at light output currents,  $V_{OUT}$  rises and forces the  $V_C$  pin below the threshold that temporarily inhibits switching. After  $V_{OUT}$  drops slightly and  $V_C$  rises ~25mV the switching is resumed, initially in the buck-boost region. Burst Mode operation can increase efficiency at light load currents by eliminating unnecessary switching activity and related power losses. Burst Mode operation handles reverse-current detection similar to discontinuous mode. The M4 switch is turned off when reverse current is detected.

**Forced Continuous Mode:** The forced continuous mode allows the inductor current to reverse directions without any switches being forced “off” to prevent this from happening. At very light load currents the inductor current will swing positive and negative as the appropriate average

current is delivered to the output. During soft-start, when the SS pin is below 1.6V, the part will be forced into discontinuous mode to prevent pulling current from the output to the input. After SS rises above 1.6V, forced continuous mode will be enabled.

### Voltage Regulation Loops

The LT8705 provides two constant-voltage regulation loops, one for output voltage and one for input voltage. A resistor divider between  $V_{OUT}$ , FBOUT and GND senses the output voltage. As with traditional voltage regulators, when FBOUT rises near or above the reference voltage of EA4 (1.207V typical, see Block Diagram), the  $V_C$  voltage is reduced to command the amount of current that keeps  $V_{OUT}$  regulated to the desired voltage.

The input voltage can also be sensed by connecting a resistor divider between  $V_{IN}$ , FBIN and GND. When the FBIN voltage falls near or below the reference voltage of EA3 (1.205V typical, see Block Diagram), the  $V_C$  voltage is reduced to also reduce the input current. For applications with a high input source impedance (i.e., a solar panel), the input voltage regulation loop can prevent the input voltage from becoming too low under high output load conditions. For applications with a lower input source impedance (i.e., batteries and voltage supplies), the FBIN pin can be used to stop switching activity when the input power supply voltage gets too low for proper system operation. See the Applications Information section for more information about setting up the voltage regulation loops.

### Current Monitoring and Regulation

The LT8705 provides two constant-current regulation loops, one for input current and one for output current. A sensing resistor close to the input capacitor, sensed by CSPIN and CSNIN, monitors the input current. A current, linearly proportional to the sense voltage ( $V_{CSPIN} - V_{CSNIN}$ ), is forced out of the IMON\_IN pin and into an external resistor. The resulting voltage  $V_{IMON\_IN}$  is therefore linearly proportional to the input current. Similarly, a sensing resistor close to the output capacitor, and sensed by CSPOUT and CSNOOUT will monitor the output current and generate a voltage  $V_{IMON\_OUT}$  that is linearly proportional to the output current.

## OPERATION

When the input or output current causes the respective IMON\_IN or IMON\_OUT voltage to rise near or above 1.208V (typical), the  $V_C$  pin voltage will be pulled down to maintain the desired maximum input and/or output current (see EA1 and EA2 on the Block Diagram). The input current limit function prevents overloading the DC input source, while the output current limit provides a building block for battery charger or LED driver applications. It can also serve as short-circuit protection for a constant-voltage regulator. See the Applications Information section for more information about setting up the current regulation loops.

### SRVO Pins

The QFN package has four open-drain SRVO pins: SRVO\_FBIN, SRVO\_FBOUT, SRVO\_IIN, SRVO\_IOUT. Place pull-up resistors from the desired SRVO pin(s) to a power supply less than 30V (i.e., the LDO33 pin) to enable reading of their logic states. The SRVO\_FBOUT, SRVO\_IIN and SRVO\_IOUT pins are pulled low when their associated error amp (EA4, EA2, EA1) input voltages are near or greater than their regulation voltages ( $\cong 1.2V$  typical). SRVO\_FBIN is pulled low when FBIN is near or lower than

its regulation voltage ( $\cong 1.2V$  typical). The SRVO pins can therefore be used as indicators of when their respective feedback loops are active. For example, the SRVO\_FBOUT pin pulls low when FBOUT rises to within 29mV (typical, see Electrical Characteristics) of its regulation voltage (1.207V typical). The pull-down turns off after FBOUT falls to more than 44mV (typical) lower than its regulation voltage. As another example, the SRVO\_IOUT pin can be read to determine when the output current has nearly reached its predetermined limit. A logic “1” on SRVO\_IOUT indicates that the output current has not reached the current limit and a logic “0” indicates that it has.

### CLKOUT and Temperature Sensing

The CLKOUT pin toggles at the LT8705's internal clock frequency whether the internal clock is synchronized to an external source or is free-running based on the external  $R_T$  resistor. The CLKOUT pin can be used to synchronize other devices to the LT8705's switching frequency. Also, the duty cycle of CLKOUT is proportional to the die temperature and can be used to monitor the die for thermal issues.

## APPLICATIONS INFORMATION

The first page shows a typical LT8705 application circuit. After the switching frequency is selected, external component selection continues with the selection of  $R_{SENSE}$  and the inductor value. Next, the power MOSFETs are selected. Finally,  $C_{IN}$  and  $C_{OUT}$  are selected. The following examples and equations assume continuous conduction mode unless otherwise specified. The circuit can be configured for operation up to an input and/or output voltage of 80V.

### Operating Frequency Selection

The LT8705 uses a constant frequency architecture between 100kHz and 400kHz. The frequency can be set using the internal oscillator or can be synchronized to an external clock source. Selection of the switching frequency is a trade-off between efficiency and component size. Low frequency operation increases efficiency by reducing MOSFET switching losses, but requires more inductance and/or capacitance to maintain low output ripple voltage. For high power applications, consider operating at lower frequencies to minimize MOSFET heating from switching losses. The switching frequency can be set by placing an appropriate resistor from the  $R_T$  pin to ground and tying the SYNC pin low. The frequency can also be synchronized to an external clock source driven into the SYNC pin. The following sections provide more details.

### Internal Oscillator

The operating frequency of the LT8705 can be set using the internal free-running oscillator. When the SYNC pin is driven low (<0.5V), the frequency of operation is set by the value of a resistor from the  $R_T$  pin to ground. An internally trimmed timing capacitor resides inside the IC. The oscillator frequency is calculated using the following formula:

$$f_{OSC} = \left( \frac{43,750}{R_T + 1} \right) \text{kHz}$$

where  $f_{OSC}$  is in kHz and  $R_T$  is in  $k\Omega$ . Conversely,  $R_T$  (in  $k\Omega$ ) can be calculated from the desired frequency (in kHz) using:

$$R_T = \left( \frac{43,750}{f_{OSC}} - 1 \right) \text{k}\Omega$$

### SYNC Pin and Clock Synchronization

The operating frequency of the LT8705 can be synchronized to an external clock source. To synchronize to the external source, simply provide a digital clock signal into the SYNC pin. The LT8705 will operate at the SYNC clock frequency.

The duty cycle of the SYNC signal must be between 20% and 80% for proper operation. Also, the frequency of the SYNC signal must meet the following two criteria:

1. SYNC may not toggle outside the frequency range of 100kHz to 400kHz unless it is stopped low to enable the free-running oscillator.
2. The SYNC pin frequency can always be higher than the free-running oscillator set frequency,  $f_{OSC}$ , but should not be less than 25% below  $f_{OSC}$ .

After SYNC begins toggling, it is recommended that switching activity is stopped before the SYNC pin stops toggling. Excess inductor current can result when SYNC stops toggling as the LT8705 transitions from the external SYNC clock source to the internal free-running oscillator clock. Switching activity can be stopped by driving either the SWEN or  $\overline{SHDN}$  pin low.

### CLKOUT Pin and Clock Synchronization

The CLKOUT pin can drive up to 200pF and toggles at the LT8705's internal clock frequency whether the internal clock is synchronized to the SYNC pin or is free-running based on the external  $R_T$  resistor. The rising edge of CLKOUT is approximately 180° out of phase from the internal clock's rising edge or the SYNC pin's rising edge if it is toggling. CLKOUT toggles only in normal mode (see Figure 2).

The CLKOUT pin can be used to synchronize other devices to the LT8705's switching frequency. For example, the CLKOUT pin can be tied to the SYNC pin of another LT8705 regulator which will operate approximately 180° out of phase of the master LT8705 due to the CLKOUT phase shift. The frequency of the master LT8705 can be set by the external  $R_T$  resistor or by toggling the SYNC pin. CLKOUT will begin oscillating after the master LT8705 enters normal mode (see Figure 2). Note that the  $R_T$  pin of the slave LT8705 must have a resistor tied to ground. In general, use the same value  $R_T$  resistor for all of the synchronized LT8705s.

8705ff

## APPLICATIONS INFORMATION

The duty cycle of CLKOUT is proportional to the die temperature and can be used to monitor the die for thermal issues. See the Junction Temperature Measurement section for more information.

### Inductor Current Sensing and Slope Compensation

The LT8705 operates using inductor current mode control. As described previously in the Power Switch Control section, the LT8705 measures the peak of the inductor current waveform in the boost region and the valley of the inductor current waveform in the buck region. The inductor current is sensed across the  $R_{SENSE}$  resistor with pins CSP and CSN. During any given cycle, the peak (boost region) or valley (buck region) of the inductor current is controlled by the  $V_C$  pin voltage.

Slope compensation provides stability in constant-frequency current mode control architectures by preventing subharmonic oscillations at high duty cycles. This is accomplished internally by adding a compensating ramp to the inductor current signal in the boost region, or subtracting a ramp from the inductor current signal in the buck region. At higher duty cycles, this results in a reduction of maximum inductor current in the boost region, and an increase of the maximum inductor current in the buck region. For example, refer to the Maximum Inductor Current Sense Voltage vs Duty Cycle graph in the Typical Performance Characteristics section. The graph shows that, with  $V_C$  at its maximum voltage, the maximum inductor sense voltage  $V_{RSENSE}$  is between 78mV and 117mV depending on the duty cycle. It also shows that the maximum inductor valley current in the buck region is 86mV increasing to ~130mV at higher duty cycles.

### $R_{SENSE}$ Selection and Maximum Current

The  $R_{SENSE}$  resistance must be chosen properly to achieve the desired amount of output current. Too much resistance can limit the output current below the application requirements. Start by determining the maximum allowed  $R_{SENSE}$  resistance in the boost region,  $R_{SENSE(MAX,BOOST)}$ . Follow this by finding the maximum allowed  $R_{SENSE}$  resistance in the buck region,  $R_{SENSE(MAX,BUCK)}$ . The selected  $R_{SENSE}$  resistance must be smaller than both.

**Boost Region:** In the boost region, the maximum output current capability is the least when  $V_{IN}$  is at its minimum and  $V_{OUT}$  is at its maximum. Therefore  $R_{SENSE}$  must be chosen to meet the output current requirements under these conditions.

Start by finding the boost region duty cycle when  $V_{IN}$  is minimum and  $V_{OUT}$  is maximum using:

$$DC_{(MAX,M3,BOOST)} \cong \left( 1 - \frac{V_{IN(MIN)}}{V_{OUT(MAX)}} \right) \cdot 100\%$$

For example, an application with a  $V_{IN}$  range of 12V to 48V and  $V_{OUT}$  set to 36V will have:

$$DC_{(MAX,M3,BOOST)} \cong \left( 1 - \frac{12V}{36V} \right) \cdot 100\% = 67\%$$

Referring to the Maximum Inductor Current Sense Voltage graph in the Typical Performance Characteristics section, the maximum  $R_{SENSE}$  voltage at 67% duty cycle is  $\cong 93mV$ , or:

$$V_{RSENSE(MAX,BOOST,MAX)} \cong 93mV$$

for  $V_{IN} = 12V$ ,  $V_{OUT} = 36V$ .

Next, the inductor ripple current in the boost region must be determined. If the main inductor  $L$  is not known, the maximum ripple current  $\Delta I_{L(MAX,BOOST)}$  can be estimated by choosing  $\Delta I_{L(MAX,BOOST)}$  to be 30% to 50% of the maximum inductor current in the boost region as follows:

$$\Delta I_{L(MAX,BOOST)} \cong \frac{V_{OUT(MAX)} \cdot I_{OUT(MAX,BOOST)}}{V_{IN(MIN)} \cdot \left( \frac{100\%}{\%Ripple} - 0.5 \right)} A$$

where:

$I_{OUT(MAX,BOOST)}$  is the maximum output load current required in the boost region

%Ripple is 30% to 50%

For example, using  $V_{OUT(MAX)} = 36V$ ,  $V_{IN(MIN)} = 12V$ ,  $I_{OUT(MAX,BOOST)} = 2A$  and %Ripple = 40% we can estimate:

$$\Delta I_{L(MAX,BOOST)} \cong \frac{36V \cdot 2A}{12V \cdot \left( \frac{100\%}{40\%} - 0.5 \right)} = 3A$$

## APPLICATIONS INFORMATION

Otherwise, if the inductor value is already known then  $\Delta I_{L(MAX,BOOST)}$  can be more accurately calculated as follows:

$$\Delta I_{L(MAX,BOOST)} = \frac{\left( \frac{DC_{(MAX,M3,BOOST)}}{100\%} \right) \cdot V_{IN(MIN)}}{f \cdot L} \text{ A}$$

where:

$DC_{(MAX,M3,BOOST)}$  is the maximum duty cycle percentage in the boost region as calculated previously.

$f$  is the switching frequency

$L$  is the inductance of the main inductor

After the maximum ripple current is known, the maximum allowed  $R_{SENSE}$  in the boost region can be calculated as follows:

$$R_{SENSE(MAX,BOOST)} = \frac{2 \cdot V_{RSENSE(MAX,BOOST,MAX)} \cdot V_{IN(MIN)}}{(2 \cdot I_{OUT(MAX,BOOST)} \cdot V_{OUT(MIN)}) + (\Delta I_{L(MAX,BOOST)} \cdot V_{IN(MIN)})} \Omega$$

where  $V_{RSENSE(MAX,BOOST,MAX)}$  is the maximum inductor current sense voltage as discussed in the previous section.

Using values from the previous examples:

$$R_{SENSE(MAX,BOOST)} = \frac{2 \cdot 93\text{mV} \cdot 12}{(2 \cdot 2\text{A} \cdot 36\text{V}) + (3\text{A} \cdot 12\text{V})} = 12.4\text{m}\Omega$$

**Buck Region:** In the buck region, the maximum output current capability is the least when operating at the minimum duty cycle. This is because the slope compensation ramp increases the maximum  $R_{SENSE}$  voltage with increasing duty cycle. The minimum duty cycle for buck operation can be calculated using:

$$DC_{(MIN,M2,BUCK)} \cong t_{ON(M2,MIN)} \cdot f \cdot 100\%$$

where  $t_{ON(M2,MIN)}$  is 260ns (typical value, see Electrical Characteristics)

Before calculating the maximum  $R_{SENSE}$  resistance, however, the inductor ripple current must be determined. If the main inductor  $L$  is not known, the ripple current  $\Delta I_{L(MIN,BUCK)}$  can be estimated by choosing  $\Delta I_{L(MIN,BUCK)}$  to be 10% of the maximum inductor current in the buck region as follows:

$$\Delta I_{L(MIN,BUCK)} \cong \frac{I_{OUT(MAX,BUCK)}}{\left( \frac{100\%}{10\%} - 0.5 \right)} \text{ A}$$

where:

$I_{OUT(MAX,BUCK)}$  is the maximum output load current required in the buck region.

If the inductor value is already known then  $\Delta I_{L(MIN,BUCK)}$  can be calculated as follows:

$$\Delta I_{L(MIN,BUCK)} = \frac{\left( \frac{DC_{(MIN,M2,BUCK)}}{100\%} \right) \cdot V_{OUT(MIN)}}{f \cdot L} \text{ A}$$

where:

$DC_{(MIN,M2,BUCK)}$  is the minimum duty cycle percentage in the buck region as calculated previously.

$f$  is the switching frequency

$L$  is the inductance of the main inductor

After the inductor ripple current is known, the maximum allowed  $R_{SENSE}$  in the buck region can be calculated as follows:

$$R_{SENSE(MAX,BUCK)} = \frac{2 \cdot 86\text{mV}}{(2 \cdot I_{OUT(MAX,BUCK)}) - \Delta I_{L(MIN,BUCK)}}$$

## APPLICATIONS INFORMATION

**Final  $R_{SENSE}$  Value:** The final  $R_{SENSE}$  value should be lower than both  $R_{SENSE(MAX,BOOST)}$  and  $R_{SENSE(MAX,BUCK)}$ . A margin of 30% or more is recommended.

Figure 8 shows approximately how the maximum output current and maximum inductor current would vary with  $V_{IN}/V_{OUT}$  while all other operating parameters remain constant (frequency = 350kHz, inductance = 10 $\mu$ H,  $R_{SENSE}$  = 10m $\Omega$ ). This graph is normalized and accounts for changes in maximum current due to the slope compensation ramps and the effects of changing ripple current. The curve is theoretical, but can be used as a guide to predict relative changes in maximum output and inductor current over a range of  $V_{IN}/V_{OUT}$  voltages.

### Reverse Current Limit

When the forced continuous mode is selected (MODE pin low), inductor current is allowed to reverse directions and flow from the  $V_{OUT}$  side to the  $V_{IN}$  side. This can lead to current sinking from the output and being forced into the input. The reverse current is at a maximum magnitude when  $V_C$  is lowest. The graph of Minimum Inductor Current Sense Voltage in FCM in the Typical Performance Characteristics section can help to determine the maximum reverse current capability.

### Inductor Selection

For high efficiency, choose an inductor with low core loss, such as ferrite. Also, the inductor should have low DC resistance to reduce the  $I^2R$  losses, and must be able to handle the peak inductor current without saturating. To minimize radiated noise, use a toroid, pot core or shielded bobbin inductor.

The operating frequency and inductor selection are interrelated in that higher operating frequencies allow the use of smaller inductor and capacitor values. The following sections discuss several criteria to consider when choosing an inductor value. For optimal performance, choose an inductor that meets all of the following criteria.

### Inductor Selection: Adequate Load Current in the Boost Region

Small value inductors result in increased ripple currents and thus, due to the limited peak inductor current, decrease the maximum average current that can be provided to the load ( $I_{OUT}$ ) while operating in the boost region.

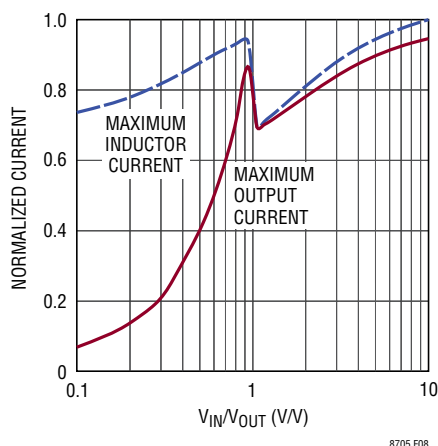

Figure 8. Currents vs  $V_{IN}/V_{OUT}$  Ratio

## APPLICATIONS INFORMATION

In order to provide adequate load current at low  $V_{IN}$  voltages in the boost region, L should be at least:

$$L_{(MIN1,BOOST)} \cong \frac{V_{IN(MIN)} \cdot \left( \frac{DC_{(MAX,M3,BOOST)}}{100\%} \right)}{2 \cdot f \cdot \left( \frac{V_{RSENSE(MAX,BOOST,MAX)}}{R_{SENSE}} - \frac{I_{OUT(MAX)} \cdot V_{OUT(MAX)}}{V_{IN(MIN)}} \right)}$$

where:

$DC_{(MAX,M3,BOOST)}$  is the maximum duty cycle percentage of the M3 switch (see  $R_{SENSE}$  Selection and Maximum Current section).

f is the switching frequency

$V_{RSENSE(MAX,BOOST,MAX)}$  is the maximum current sense voltage in the boost region at maximum duty cycle (see  $R_{SENSE}$  Selection and Maximum Current section)

Negative values of  $L_{(MIN1,BOOST)}$  indicate that the output load current  $I_{OUT}$  can't be delivered in the boost region because the inductor current limit is too low. If  $L_{(MIN1,BOOST)}$  is too large or is negative, consider reducing the  $R_{SENSE}$  resistor value to increase the inductor current limit.

### Inductor Selection: Subharmonic Oscillations

The LT8705's internal slope compensation circuits will prevent subharmonic oscillations that can otherwise occur when  $V_{IN}/V_{OUT}$  is less than 0.5 or greater than 2. The slope compensation circuits will prevent these oscillations provided that the inductance exceeds a minimum value (see the earlier section Inductor Current Sensing and Slope Compensation for more information). Choose an inductance greater than all of the relevant  $L_{(MIN)}$  limits discussed below. Negative results can be interpreted as zero.

In the boost region, if  $V_{OUT}$  can be greater than twice  $V_{IN}$ , calculate  $L_{(MIN2,BOOST)}$  as follows:

$$L_{(MIN2,BOOST)} = \frac{\left[ V_{OUT(MAX)} - \left( \frac{V_{IN(MIN)} \cdot V_{OUT(MAX)}}{V_{OUT(MAX)} - V_{IN(MIN)}} \right) \right] \cdot R_{SENSE}}{0.08 \cdot f} \text{ H}$$

In the buck region, if  $V_{IN}$  can be greater than twice  $V_{OUT}$ , calculate  $L_{(MIN1,BUCK)}$  as follows:

$$L_{(MIN1,BUCK)} = \frac{V_{IN(MAX)} \cdot \left( 1 - \frac{V_{OUT(MAX)}}{V_{IN(MAX)} - V_{OUT(MIN)}} \right) \cdot R_{SENSE}}{0.08 \cdot f} \text{ H}$$

### Inductor Selection: Maximum Current Rating

The inductor must have a rating greater than its peak operating current to prevent inductor saturation resulting in efficiency loss. The peak inductor current in the boost region is:

$$I_{L(MAX,BOOST)} \cong I_{OUT(MAX)} \cdot \frac{V_{OUT(MAX)}}{V_{IN(MIN)}} + \left( \frac{V_{IN(MIN)} \cdot \left( \frac{DC_{(MAX,M3,BOOST)}}{100\%} \right)}{2 \cdot L \cdot f} \right) \text{ A}$$

where  $DC_{(MAX,M3,BOOST)}$  is the maximum duty cycle percentage of the M3 switch (see  $R_{SENSE}$  Selection and Maximum Current section).

## APPLICATIONS INFORMATION

The peak inductor current when operating in the buck region is:

$$I_{L(MAX,BUCK)} \cong I_{OUT(MAX)} + \left[ \frac{V_{OUT(MIN)} \cdot \left( \frac{DC_{(MAX,M2,BUCK)}}{100\%} \right)}{2 \cdot L \cdot f} \right] A$$

where  $DC_{(MAX,M2,BUCK)}$  is the maximum duty cycle percentage of the M2 switch in the buck region given by:

$$DC_{(MAX,M2,BUCK)} \cong \left( 1 - \frac{V_{OUT(MIN)}}{V_{IN(MAX)}} \right) \cdot 100\%$$

Note that the inductor current can be higher during load transients and if the load current exceeds the expected maximum  $I_{OUT(MAX)}$ . It can also be higher during start-up if inadequate soft-start capacitance is used or during output shorts. Consider using the output current limiting to prevent the inductor current from becoming excessive. Output current limiting is discussed later in the Input/Output Current Monitoring and Limiting section. Careful board evaluation of the maximum inductor current is recommended.

### Power MOSFET Selection and Efficiency Considerations

The LT8705 requires four external N-channel power MOSFETs, two for the top switches (switches M1 and M4, shown in Figure 3) and two for the bottom switches (switches M2 and M3, shown in Figure 3). Important parameters for the power MOSFETs are the breakdown voltage,  $V_{BR,DSS}$ , threshold voltage,  $V_{GS,TH}$ , on-resistance,  $R_{DS(ON)}$ , reverse-transfer capacitance,  $C_{RSS}$  (gate-to-drain capacitance), and maximum current,  $I_{DS(MAX)}$ . The gate drive voltage is set by the 6.35V  $GATEV_{CC}$  supply. Consequently, logic-level threshold MOSFETs must be used in LT8705 applications.

It is very important to consider power dissipation when selecting power MOSFETs. The most efficient circuit will use MOSFETs that dissipate the least amount of power. Power dissipation must be limited to avoid overheating

that might damage the devices. For most buck-boost applications the M1 and M3 switches will have the highest power dissipation where M2 will have the lowest unless the output becomes shorted. In some cases it can be helpful to use two or more MOSFETs in parallel to reduce power dissipation in each device. This is most helpful when power is dominated by  $I^2R$  losses while the MOSFET is “on”. The additional capacitance of connecting MOSFETs in parallel can sometimes slow down switching edge rates and consequently increase total switching power losses.

The following sections provide guidelines for calculating power consumption of the individual MOSFETs. From a known power dissipation, the MOSFET junction temperature can be obtained using the following formula:

$$T_J = T_A + P \cdot R_{TH(JA)}$$

where:

$T_J$  is the junction temperature of the MOSFET

$T_A$  is the ambient air temperature

$P$  is the power dissipated in the MOSFET

$R_{TH(JA)}$  is the MOSFET’s thermal resistance from the junction to the ambient air. Refer to the manufacturer’s data sheet.

$R_{TH(JA)}$  normally includes the  $R_{TH(JC)}$  for the device plus the thermal resistance from the case to the ambient temperature  $R_{TH(JC)}$ . Compare the calculated value of  $T_J$  to the manufacturer’s data sheets to help choose MOSFETs that will not overheat.

**Switch M1:** The power dissipation in switch M1 comes from two primary components: (1)  $I^2R$  power when the switch is fully turned “on” and inductor current is flowing through the drain to source connections and (2) power dissipated while the switch is turning “on” or “off”. As the switch turns “on” and “off” a combination of high current and high voltage causes high power dissipation in the MOSFET. Although the switching times are short, the average power dissipation can still be significant and is often the dominant source of power in the MOSFET. Depending on the application, the maximum power dissipation in the M1 switch can happen in the buck region when  $V_{IN}$  is highest,  $V_{OUT}$  is highest, and switching power losses

## APPLICATIONS INFORMATION

are greatest or in the boost region when  $V_{IN}$  is smallest,  $V_{OUT}$  is highest and M1 is always on. Switch M1 power consumption can be approximated as:

$$P_{M1} = P_I^2 R + P_{SWITCHING}$$

$$\cong \left( \frac{V_{OUT}}{V_{IN}} \cdot I_{OUT}^2 \cdot R_{DS(ON)} \cdot \rho_{\tau} \right) + (V_{IN} \cdot I_{OUT} \cdot f \cdot t_{RF1}) W \text{ (BUCK REGION)}$$

$$\cong \left( \left( \frac{V_{OUT}}{V_{IN}} \cdot I_{OUT} \right)^2 \cdot R_{DS(ON)} \cdot \rho_{\tau} \right) + 0 W \text{ (BOOST REGION)}$$

where:

the  $P_{SWITCHING}$  term is 0 in the boost region

$t_{RF1}$  is the average of the SW1 pin rise and fall times. Typical values are 20ns to 40ns depending on the MOSFET capacitance and  $V_{IN}$  voltage.

$\rho_{\tau}$  is a normalization factor (unity at 25°C) accounting for the significant variation in MOSFET on-resistance with temperature, typically about 0.4%/°C, as shown in Figure 9. For a maximum junction temperature of 125°C, using a value  $\rho_{\tau} = 1.5$  is reasonable.

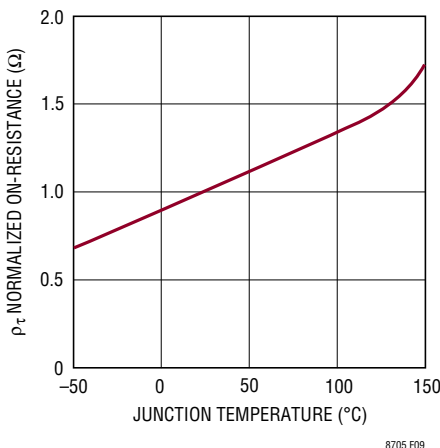

Figure 9. Normalized MOSFET  $R_{DS(ON)}$  vs Temperature

Since the switching power ( $P_{SWITCHING}$ ) often dominates, look for MOSFETs with lower  $C_{RSS}$  or consider operating at a lower frequency to minimize power loss and increase efficiency.

**Switch M2:** In most cases the switching power dissipation in the M2 switch is quite small and  $I^2R$  power losses dominate.  $I^2R$  power is greatest in the buck region where the switch operates as the synchronous rectifier. Higher  $V_{IN}$  and lower  $V_{OUT}$  causes the M2 switch to be “on” for the most amount of time, leading to the highest power consumption. The M2 switch power consumption in the buck region can be approximated as:

$$P_{(M2,BUCK)} \cong \left( \frac{V_{IN} - V_{OUT}}{V_{IN}} \cdot I_{OUT(MAX)}^2 \cdot R_{DS(ON)} \cdot \rho_{\tau} \right) W$$

**Switch M3:** Switch M3 operates in the boost and buck-boost regions as a control switch. Similar to the M1 switch, the power dissipation comes from  $I^2R$  power and switching power. The maximum power dissipation is when  $V_{IN}$  is the lowest and  $V_{OUT}$  is the highest. The following expression approximates the power dissipation in the M3 switch under those conditions:

$$P_{M3} = P_I^2 R + P_{SWITCHING} \cong$$

$$\left( \frac{(V_{OUT} - V_{IN}) \cdot V_{OUT}}{V_{IN}^2} \cdot I_{OUT}^2 \cdot R_{DS(ON)} \cdot \rho_{\tau} \right) + \left( V_{OUT}^2 \cdot I_{OUT} \cdot f \cdot \frac{t_{RF2}}{V_{IN}} \right) W$$

where the total power is 0 in the buck region.

## APPLICATIONS INFORMATION

$t_{RF2}$  is the average of the SW2 pin rise and fall times and, similar to  $t_{RF1}$ , is typically 20ns to 40ns.

As with the M1 switch, the switching power ( $P_{SWITCHING}$ ) often dominates. Look for MOSFETs with lower  $C_{RSS}$  or consider operating at a lower frequency to minimize power loss and increase efficiency.

**Switch M4:** In most cases the switching power dissipation in the M4 switch is quite small and  $I^2R$  power losses dominate.  $I^2R$  power is greatest in the boost region where the switch operates as the synchronous rectifier. Lower  $V_{IN}$  and higher  $V_{OUT}$  increases the inductor current for a given  $I_{OUT}$ , leading to the highest power consumption. The M4 switch power consumption in the boost region can be approximated as:

$$P_{(M4,BOOST)} \cong \left( \frac{V_{OUT}}{V_{IN}} \cdot I_{OUT}^2 \cdot \rho_{\tau} \cdot R_{DS(ON)} \right) W$$

**Gate Resistors:** In some cases it can be beneficial to add  $1\Omega$  to  $10\Omega$  of resistance between some of the NMOS gate pins and their respective gate driver pins on the LT8705 (i.e., TG1, BG1, TG2, BG2). Due to parasitic inductance and capacitance, ringing can occur on SW1 or SW2 when low capacitance MOSFETs are turned on/off too quickly. The ringing can be of greatest concern when operating the MOSFETs or the LT8705 near the rated voltage limits. Additional gate resistance slows the switching speed, minimizing the ringing.

Excessive gate resistance can have two negative side effects on performance:

1. Slowing the switch transition times can also increase power dissipation in the switch. This is described above in the Switch M1 and Switch M3 sections.
2. Capacitive coupling from the SW1 or SW2 pin to the switch gate node can turn it on when it's supposed to be off, thus increasing power dissipation. With too much gate resistance, this would most commonly happen to the M2 switch when SW1 is rising.

Careful board evaluation should be performed when optimizing the gate resistance values. SW1 and SW2 pin ringing can be affected by the inductor current levels,

therefore board evaluation should include measurements at a wide range of load currents. When performing PCB measurements of the SW1 and SW2 pins, be sure to use a very short ground post from the PCB ground to the scope probe ground sleeve in order to minimize false inductive voltages readings.

### $C_{IN}$ and $C_{OUT}$ Selection

Input and output capacitance is necessary to suppress voltage ripple caused by discontinuous current moving in and out of the regulator. A parallel combination of capacitors is typically used to achieve high capacitance and low ESR (equivalent series resistance). Dry tantalum, special polymer, aluminum electrolytic and ceramic capacitors are all available in surface mount packages. Capacitors with low ESR and high ripple current ratings, such as OS-CON and POSCAP are also available.

Ceramic capacitors should be placed near the regulator input and output to suppress high frequency switching spikes. A ceramic capacitor, of at least  $1\mu F$ , should also be placed from  $V_{IN}$  to GND as close to the LT8705 pins as possible. Due to their excellent low ESR characteristics ceramic capacitors can significantly reduce input ripple voltage and help reduce power loss in the higher ESR bulk capacitors. X5R or X7R dielectrics are preferred, as these materials retain their capacitance over wide voltage and temperature ranges. Many ceramic capacitors, particularly 0805 or 0603 case sizes, have greatly reduced capacitance at the desired operating voltage.

**Input Capacitance:** Discontinuous input current is highest in the buck region due to the M1 switch toggling on and off. Make sure that the  $C_{IN}$  capacitor network has low enough ESR and is sized to handle the maximum RMS current. For buck operation, the input RMS current is given by:

$$I_{RMS} \cong I_{OUT(MAX)} \cdot \frac{V_{OUT}}{V_{IN}} \cdot \sqrt{\frac{V_{IN}}{V_{OUT}} - 1}$$

This formula has a maximum at  $V_{IN} = 2V_{OUT}$ , where  $I_{RMS} = I_{OUT(MAX)}/2$ . This simple worst-case condition is commonly used for design because even significant deviations do not offer much relief.

## APPLICATIONS INFORMATION

The maximum input ripple due to the voltage drop across the ESR is approximately:

$$\Delta V_{(\text{BUCK,ESR})} \cong \frac{V_{\text{IN(MAX)}} \cdot I_{\text{OUT(MAX)}}}{V_{\text{OUT(MIN)}}} \cdot \text{ESR}$$

**Output Capacitance:** The output capacitance ( $C_{\text{OUT}}$ ) is necessary to reduce the output voltage ripple caused by discontinuities and ripple in the output and load currents. The effects of ESR and the bulk capacitance must be considered when choosing the right capacitor for a given output ripple voltage. The steady-state output ripple due to charging and discharging the bulk output capacitance is given by the following equations:

$$\Delta V_{(\text{BOOST,CAP})} \cong \frac{I_{\text{OUT}} \cdot (V_{\text{OUT}} - V_{\text{IN}})}{C_{\text{OUT}} \cdot V_{\text{IN}} \cdot f} V \text{ for } V_{\text{OUT}} > V_{\text{IN}}$$

$$\Delta V_{(\text{BUCK,CAP})} \cong \frac{V_{\text{OUT}} \cdot \left(1 - \frac{V_{\text{OUT}}}{V_{\text{IN}}}\right)}{8 \cdot L \cdot f^2 \cdot C_{\text{OUT}}} V \text{ for } V_{\text{OUT}} < V_{\text{IN}}$$

The maximum output ripple due to the voltage drop across the ESR is approximately:

$$\Delta V_{(\text{BOOST,ESR})} \cong \frac{V_{\text{OUT(MAX)}} \cdot I_{\text{OUT(MAX)}}}{V_{\text{IN(MIN)}}} \cdot \text{ESR}$$

As with  $C_{\text{IN}}$ , multiple capacitors placed in parallel may be needed to meet the ESR and RMS current handling requirements.

### Schottky Diode (D1, D2) Selection

The Schottky diodes, D1 and D2, shown in Figure 1, conduct during the dead time between the conduction of the power MOSFET switches. They are intended to prevent the body diodes of synchronous switches M2 and M4 from turning on and storing charge. For example, D2 significantly reduces reverse-recovery current between switch M4 turn-off and switch M3 turn-on, which improves converter efficiency, reduces switch M3 power dissipation and reduces noise in the inductor current sense resistor ( $R_{\text{SENSE}}$ ) when M3 turns on. In order for the diode to be effective, the inductance between it and the synchronous

switch must be as small as possible, mandating that these components be placed adjacently.

For applications with high input or output voltages (typically >40V) avoid Schottky diodes with excessive reverse-leakage currents particularly at high temperatures. Some ultralow  $V_F$  diodes will trade off increased high temperature leakage current for reduced forward voltage. Diode D1 can have a reverse voltage up to  $V_{\text{IN}}$  and D2 can have a reverse voltage up to  $V_{\text{OUT}}$ . The combination of high reverse voltage and current can lead to self heating of the diode. Besides reducing efficiency, this can increase leakage current which increases temperatures even further. Choose packages with lower thermal resistance ( $\theta_{\text{JA}}$ ) to minimize self heating of the diodes.

### Topside MOSFET Driver Supply ( $C_{\text{B1}}$ , $D_{\text{B1}}$ , $C_{\text{B2}}$ , $D_{\text{B2}}$ )

The top MOSFET drivers (TG1 and TG2) are driven digitally between their respective SW and BOOST pin voltages. The BOOST voltages are biased from floating bootstrap capacitors  $C_{\text{B1}}$  and  $C_{\text{B2}}$ , which are normally recharged through external silicon diodes  $D_{\text{B1}}$  and  $D_{\text{B2}}$  when the respective top MOSFET is turned off. The capacitors are charged to about 6.3V (about equal to  $\text{GATEV}_{\text{CC}}$ ) forcing the  $V_{\text{BOOST1-SW1}}$  and  $V_{\text{BOOST2-SW2}}$  voltages to be about 6.3V. The boost capacitors  $C_{\text{B1}}$  and  $C_{\text{B2}}$  need to store about 100 times the gate charge required by the top switches M1 and M4. In most applications, a 0.1 $\mu\text{F}$  to 0.47 $\mu\text{F}$ , X5R or X7R dielectric capacitor is adequate. The bypass capacitance from  $\text{GATEV}_{\text{CC}}$  to GND should be at least ten times the  $C_{\text{B1}}$  or  $C_{\text{B2}}$  capacitance.

**Boost Capacitor Charge Control Block:** When the LT8705 operates exclusively in the buck or boost region, one of the top MOSFETs, M1 or M4, can be constantly on. This prevents the respective bootstrap capacitor,  $C_{\text{B1}}$  or  $C_{\text{B2}}$ , from being recharged through the silicon diode,  $D_{\text{B1}}$  or  $D_{\text{B2}}$ . The Boost Capacitor Charge Control block (see Figure 1) keeps the appropriate BOOST pin charged in these cases. When the M1 switch is always on (boost region), current is automatically drawn from the CSPOUT and/or BOOST2 pins to charge the BOOST1 capacitor as needed. When the M4 switch is always on (buck region) current is drawn from the CSNIN and/or BOOST1 pins to charge the BOOST2 capacitor. Because of this function, CSPIN and CSNIN should be connected to a potential close

8705ff

## APPLICATIONS INFORMATION

to  $V_{IN}$ . Tie both pins to  $V_{IN}$  if they are not being used. Also, CSPOUT and CSNOUT should always be tied to a potential close to  $V_{OUT}$ , or be tied directly to  $V_{OUT}$  if not being used.

**Boost Diodes  $D_{B1}$  and  $D_{B2}$ :** Although Schottky diodes have the benefit of low forward voltage drops, they can exhibit high reverse current leakage and have the potential for thermal runaway under high voltage and temperature conditions. Silicon diodes are thus recommended for diodes  $D_{B1}$  and  $D_{B2}$ . Make sure that  $D_{B1}$  and  $D_{B2}$  have reverse breakdown voltage ratings higher than  $V_{IN(MAX)}$  and  $V_{OUT(MAX)}$  and have less than 1mA of reverse leakage current at the maximum operating junction temperature. Make sure that the reverse leakage current at high operating temperatures and voltages won't cause thermal runaway of the diode.

In some cases it is recommended that up to  $5\Omega$  of resistance is placed in series with  $D_{B1}$  and  $D_{B2}$ . The resistors reduce surge currents in the diodes and can reduce ringing at the SW and BOOST pins of the IC. Since SW pin ringing is highly dependent on PCB layout, SW pin edge rates and the type of diodes used, careful measurements directly at the SW pins of the IC are recommended. If required, a single resistor can be placed between GAT-EV<sub>CC</sub> and the common anodes of  $D_{B1}$  and  $D_{B2}$  (as in the front page application) or by placing separate resistors between the cathodes of each diode and the respective BOOST pins. Excessive resistance in series with  $D_{B1}$  and  $D_{B2}$  can reduce the BOOST-SW capacitor voltage when the M2 or M3 on-times are very short and should be avoided.

### Output Voltage

The LT8705 output voltage is set by an external feedback resistive divider carefully placed across the output capacitor. The resultant feedback signal (FBOUT) is compared with the internal precision voltage reference (typically 1.207V) by the error amplifier EA4. The output voltage is given by the equation:

$$V_{OUT} = 1.207V \cdot \left( 1 + \frac{R_{FBOUT1}}{R_{FBOUT2}} \right)$$

where  $R_{FBOUT1}$  and  $R_{FBOUT2}$  are shown in Figure 1.

### Input Voltage Regulation or Undervoltage Lockout

By connecting a resistor divider between  $V_{IN}$ , FBIN and GND, the FBIN pin provides a means to regulate the input voltage or to create an undervoltage lockout function. Referring to error amplifier EA3 in the Block Diagram, when FBIN is lower than the 1.205V reference  $V_C$  is pulled low. For example, if  $V_{IN}$  is provided by a relatively high impedance source (i.e., a solar panel) and the current draw pulls  $V_{IN}$  below a preset limit,  $V_C$  will be reduced, thus reducing current draw from the input supply and limiting the voltage drop. Note that using this function in forced continuous mode (MODE pin low) can result in current being drawn from the output and forced into the input. If this behavior is not desired then use discontinuous or Burst Mode operation.

To set the minimum or regulated input voltage use:

$$V_{IN(MIN)} = 1.205V \cdot \left( 1 + \frac{R_{FBIN1}}{R_{FBIN2}} \right)$$

where  $R_{FBIN1}$  and  $R_{FBIN2}$  are shown in Figure 1. Make sure to select  $R_{FBIN1}$  and  $R_{FBIN2}$  such that FBIN doesn't exceed 30V (absolute maximum rating) under maximum  $V_{IN}$  conditions.

This same technique can be used to create an undervoltage lockout if the LT8705 is NOT in forced continuous mode. When in Burst Mode operation or discontinuous mode, forcing  $V_C$  low will stop all switching activity. Note that this does not reset the soft-start function, therefore resumption of switching activity will not be accompanied by a soft-start.

## APPLICATIONS INFORMATION

### Input/Output Current Monitoring and Limiting

The LT8705 has independent input and output current monitor circuits that can be used to monitor and/or limit the respective currents. The current monitor circuits work as shown in Figures 10 and 11.

As described in the Topside MOSFET Driver Supply section, the CSNIN and CSPOUT pins are also connected

to the Boost Capacitor Charge Control block (also see Figure 1) and can draw current in certain conditions. In addition, all four of the current sense pins can draw bias current under normal operating conditions. As such, do not place resistors in series with any of the CSxIN or CSxOUT pins.

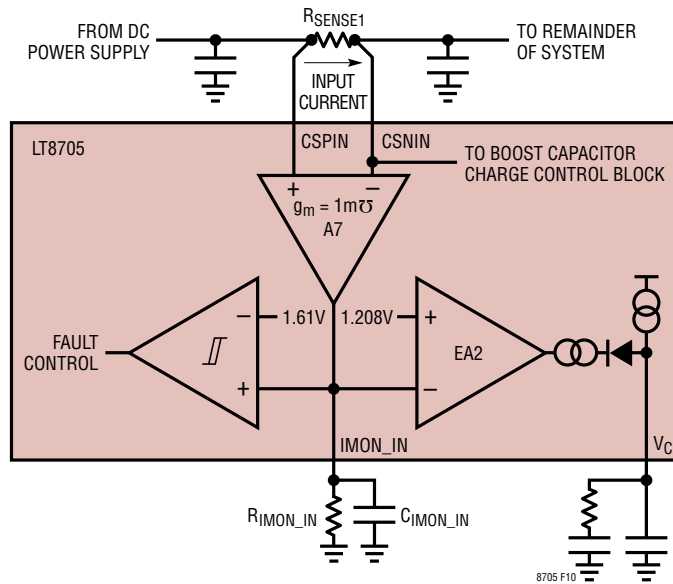

Figure 10. Input Current Monitor and Limit

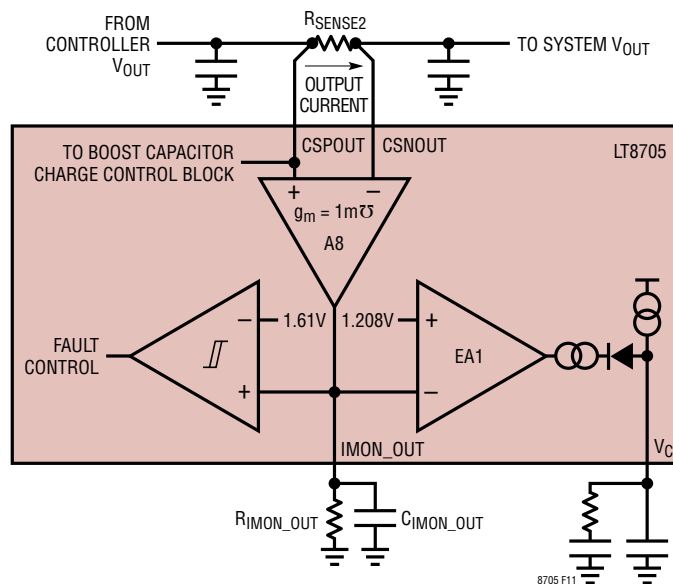

Figure 11. Output Current Monitor and Limit

## APPLICATIONS INFORMATION

Also, because of their use with the Boost Capacitor Charge Control block, tie the CSPIN and CSNIN pins to  $V_{IN}$  and tie the IMON\_IN pin to ground when the input current sensing is not in use. Similarly, the CSPOUT and CSNOUT pins should be tied to  $V_{OUT}$  and IMON\_OUT should be grounded when not in use.

The remaining discussion refers to the input current monitor circuit. All discussion and equations are applicable to the output current monitor circuit, substituting pin and device names as appropriate.

**Current Monitoring:** For input current monitoring, current flowing through  $R_{SENSE1}$  develops a voltage across CSPIN and CSNIN which is multiplied by  $1\text{mA/V}$  (typical), converting it to a current that is forced out of the IMON\_IN pin and into resistor  $R_{IMON\_IN}$  (Note: Negative CSPIN to CSNIN voltages are not multiplied and no current flows out of IMON\_IN in that case). The resulting IMON\_IN voltage is then proportional to the input current according to:

$$V_{IMON\_IN} = I_{RSENSE1} \cdot \left( R_{SENSE1} \cdot 1\text{m}\frac{\text{A}}{\text{V}} \cdot R_{IMON\_IN} \right)$$

For accurate current monitoring, the CSPIN and CSNIN voltages should be kept above 1.5V (CSPOUT and CSNOUT pins should be kept above 0V). Also, the differential voltage  $V_{CSPIN-CSNIN}$  should be kept below 100mV due to the limited amount of current that can be driven out of IMON\_IN. Finally, the IMON\_IN voltage must be filtered with capacitor  $C_{IMON\_IN}$  because the input current often has ripple and discontinuities depending on the LT8705's region of operation.  $C_{IMON\_IN}$  should be chosen by the equation:

$$C_{IMON\_IN} > \left( \frac{100}{f \cdot R_{IMON\_IN}} \right) \text{F}$$

where  $f$  is the switching frequency, to achieve adequate filtering. Additional capacitance, bringing the  $C_{IMON\_IN}$  total to  $0.1\mu\text{F}$  to  $1\mu\text{F}$ , may be necessary to maintain loop stability if the IMON\_IN pin is used in a constant-current regulation loop.

**Current Limiting:** As shown in Figure 10, IMON\_IN voltages exceeding 1.208V (typical) cause the  $V_C$  voltage to reduce, thus limiting the inductor and input currents.  $R_{IMON\_IN}$  can be selected for a desired input current limit using:

$$R_{IMON\_IN} = \left( \frac{1.208\text{V}}{I_{RSENSE(LIMIT)} \cdot 1\text{m}\frac{\text{A}}{\text{V}} \cdot R_{SENSE1}} \right) \Omega$$

For example, if  $R_{SENSE1}$  is chosen to be  $12.5\text{m}\Omega$  and the desired input current limit is 4A then:

$$R_{IMON\_IN} = \frac{1.208\text{V}}{4\text{A} \cdot 1\text{m}\frac{\text{A}}{\text{V}} \cdot 12.5\text{m}\Omega} = 24.2\text{k}\Omega$$

Review the Electrical Characteristics and the IMON Output Currents graph in the Typical Performance Characteristics section to understand the operational limits of the IMON\_OUT and IMON\_IN currents.

**Overcurrent Fault:** If IMON\_IN exceeds 1.61V (typical), a fault will occur and switching activity will stop (see Fault Conditions earlier in the data sheet). The fault current is determined by:

$$I_{RSENSE1(FAULT)} = \left( \frac{1.61\text{V}}{1.208\text{V}} \cdot I_{RSENSE1(LIMIT)} \right) \text{A}$$

For example, an input current limit set to 4A would have a fault current limit of 5.3A.

### Output Overvoltage

If the output voltage is higher than the value set by the FBOUT resistor divider, the LT8705 will respond according to the mode and region of operation. In forced continuous mode, the LT8705 will sink current into the input (see the Reverse Current Limit discussion in the Applications Information section for more information). In discontinuous mode and Burst Mode operation, switching will stop and the output will be allowed to remain high.

## APPLICATIONS INFORMATION

### INTV<sub>CC</sub> Regulators and EXTV<sub>CC</sub> Connection

The LT8705 features two PNP LDOs (low dropout regulators) that regulate the 6.35V (typical) INTV<sub>CC</sub> pin from either the V<sub>IN</sub> or EXTV<sub>CC</sub> supply pin. INTV<sub>CC</sub> powers the MOSFET gate drivers via the required GATEV<sub>CC</sub> connection and also powers the LDO33 pin regulator and much of the LT8705's internal control circuitry. The INTV<sub>CC</sub> LDO selection is determined automatically by the EXTV<sub>CC</sub> pin voltage. When EXTV<sub>CC</sub> is lower than 6.22V (typical), INTV<sub>CC</sub> is regulated from the V<sub>IN</sub> LDO. After EXTV<sub>CC</sub> rises above 6.4V (typical), INTV<sub>CC</sub> is regulated by the EXTV<sub>CC</sub> LDO instead.

Overcurrent protection circuitry typically limits the maximum current draw from either LDO to 127mA. When GATEV<sub>CC</sub> and INTV<sub>CC</sub> are below 4.65V, during start-up or during an overload condition, the typical current limit is reduced to 42mA. The INTV<sub>CC</sub> pin must be bypassed to ground with a minimum 4.7μF ceramic capacitor placed as close as possible to the INTV<sub>CC</sub> and GND pins. An additional ceramic capacitor should be placed as close as possible to the GATEV<sub>CC</sub> and GND pins to provide good bypassing to supply the high transient current required by the MOSFET gate drivers. 1μF to 4.7μF is recommended.

Power dissipated in the INTV<sub>CC</sub> LDOs must be minimized to improve efficiency and prevent overheating of the LT8705. Since LDO power dissipation is proportional to the input voltage and V<sub>IN</sub> can be as high as 80V in some applications, the EXTV<sub>CC</sub> pin is available to regulate INTV<sub>CC</sub> from a lower input voltage. The EXTV<sub>CC</sub> pin is connected to V<sub>OUT</sub> in many applications since V<sub>OUT</sub> is often regulated to a much lower voltage than the maximum V<sub>IN</sub>. During start-up, power for the MOSFET drivers, control circuits and the LDO33 pin is derived from V<sub>IN</sub> until V<sub>OUT</sub>/EXTV<sub>CC</sub> rises above 6.4V, after which the power is derived from V<sub>OUT</sub>/EXTV<sub>CC</sub>. This works well, for example, in a case where V<sub>OUT</sub> is regulated to 12V and the maximum V<sub>IN</sub> voltage is 40V. EXTV<sub>CC</sub> can be floated or grounded when not in use or can also be connected to an external power supply if available.

The maximum current drawn through the INTV<sub>CC</sub> LDO occurs under the following conditions:

1. Large (capacitive) MOSFETs are being driven at high frequencies.
2. V<sub>IN</sub> and/or V<sub>OUT</sub> is high, thus requiring more charge to turn the MOSFET gates on and off.
3. The LDO33 pin output current is high.
4. In some applications, LDO current draw is maximum when the part is operating in the buck-boost region where V<sub>IN</sub> is close to V<sub>OUT</sub> since all four MOSFETs are switching.

To check for overheating find the operating conditions that consume the most power in the LT8705 (P<sub>LT8705</sub>). This will often be under the same conditions just listed that maximize LDO current. Under these conditions monitor the CLKOUT pin duty cycle to measure the approximate die temperature. See the Junction Temperature Measurement section for more information.

Powering INTV<sub>CC</sub> from V<sub>OUT</sub>/EXTV<sub>CC</sub> can also provide enough gate drive when V<sub>IN</sub> drops as low as 2.8V. This allows the part to operate with a reduced input voltage after the output gets into regulation.

The following list summarizes the three possible connections for EXTV<sub>CC</sub>:

1. EXTV<sub>CC</sub> left open (or grounded). This will cause INTV<sub>CC</sub> to be powered from V<sub>IN</sub> through the internal 6.35V regulator at the cost of a small efficiency penalty.
2. EXTV<sub>CC</sub> connected directly to V<sub>OUT</sub> (V<sub>OUT</sub> > 6.4V). This is the normal connection for the regulator and usually provides the highest efficiency.
3. EXTV<sub>CC</sub> connected to an external supply. If an external supply is available greater than 6.4V (typical) it may be used to power EXTV<sub>CC</sub>.

## APPLICATIONS INFORMATION

### Loop Compensation

The loop stability is affected by a number of factors including the inductor value, output capacitance, load current,  $V_{IN}$ ,  $V_{OUT}$  and the  $V_C$  resistor and capacitors. The LT8705 uses internal transconductance error amplifiers driving  $V_C$  to help compensate the control loop. For most applications a 3.3nF series capacitor at  $V_C$  is a good value. The parallel capacitor (from  $V_C$  to GND) is typically 1/10th the value of the series capacitor to filter high frequency noise. A larger  $V_C$  series capacitor value may be necessary if the output capacitance is reduced. A good starting value for the  $V_C$  series resistor is 20k. Lower resistance will improve stability but will slow the loop response. Use a trim pot instead of a fixed resistor for initial bench evaluation to determine the optimum value.

### LDO33 Pin Regulator

The LT8705 includes a low dropout regulator (LDO) to regulate the LDO33 pin to 3.3V. This pin can be used to power external circuitry such as a microcontroller or other desired peripherals. The input supply for the LDO33 pin regulator is  $INTV_{CC}$ . Therefore  $INTV_{CC}$  must have sufficient voltage, typically >4.0V, to properly regulate LDO33. The LDO33 and  $INTV_{CC}$  regulators are enabled by the  $\overline{SHDN}$  pin and are not affected by SWEN. The LDO33 pin regulator has overcurrent protection circuitry that typically limits the output current to 17.25mA. An undervoltage lockout monitoring LDO disables switching activity when LDO33 falls below 3.04V (typical). LDO33 should be bypassed locally with 0.1µF or more.

### Voltage Lockouts

The LT8705 contains several voltage detectors to make sure the chip is under proper operating conditions. Table 1 summarizes the pins that are monitored and also indicates the state that the LT8705 will enter if an under or overvoltage condition is detected.

The conditions are listed in order of priority from top to bottom. If multiple over/undervoltage conditions are detected, the chip will enter the state listed highest on the table.

Table 1. Voltage Lockout Conditions

PIN	APPROXIMATE VOLTAGE CONDITION	CHIP STATE (FIGURE 2)	READ SECTION
$V_{IN}$	<2.5V	Chip Off	Operation: Start-Up
$\overline{SHDN}$	<1.18V	Chip Off	
$INTV_{CC}$ and $GATEV_{CC}$	<4.65V	Switcher Off	
SWEN	<1.18V	Switcher Off	
LDO33	<3.04	Switcher Off	
IMON_IN	>1.61V	Fault	Operation: Fault Conditions
IMON_OUT	>1.61V	Fault	
FBIN	<1.205V	—	Applications Information: Input Voltage Regulation or Undervoltage Lockout

Due to their accurate thresholds, configurable undervoltage lockouts (UVLOs) can be implemented using the  $\overline{SHDN}$ , SWEN and in some cases, FBIN pin. The UVLO function sets the turn on/off of the LT8705 at a desired minimum input voltage. For example, a resistor divider can be connected between  $V_{IN}$ ,  $\overline{SHDN}$  and GND as shown in Figures 1 and 14. From the Electrical Characteristics,  $\overline{SHDN}$  has typical rising and falling thresholds of 1.234V and 1.184V respectively. The falling threshold for turning off switching activity can be chosen using:

$$R_{SHDN1} = \frac{R_{SHDN2} \cdot (V_{(IN,CHIP\_OFF,FALLING)} - 1.184V)}{1.184V} \Omega$$

For example, choosing  $R_{SHDN2} = 20k$  and a falling  $V_{IN}$  threshold of 5.42V results in:

$$R_{SHDN1} = \frac{20k\Omega \cdot (5.42V - 1.184V)}{1.184V} = 71.5k\Omega$$

The rising threshold for enabling switching activity would be:

$$V_{(IN,CHIP\_OFF,RISING)} = V_{(IN,CHIP\_OFF,FALLING)} \cdot \frac{1.234V}{1.184V}$$

or 5.65V in this example.

## APPLICATIONS INFORMATION

Similar calculations can be used to select a resistor divider connected to SWEN that would stop switching activity during an undervoltage condition. Make sure that the divider doesn't cause SWEN to exceed 7V (absolute maximum rating) under maximum  $V_{IN}$  conditions. Using the FBIN pin as an undervoltage lockout is discussed in the Input Voltage Regulation or Undervoltage Lockout section.

### Inductor Current Sense Filtering

Certain applications may require filtering of the inductor current sense signals due to excessive switching noise that can appear across  $R_{SENSE}$ . Higher operating voltages, higher values of  $R_{SENSE}$ , and more capacitive MOSFETs will all contribute additional noise across  $R_{SENSE}$  when the SW pins transition. The CSP/CSN sense signals can be filtered by adding one of the RC networks shown in Figures 12a and 12b. Most PC board layouts can be drawn to accommodate either network on the same board. The network should be placed as close as possible to the IC. The network in Figure 12b can reduce common mode noise seen by the CSP and CSN pins of the LT8705 at the expense of some increased ground trace noise as current passes through the capacitors. A short direct path from the capacitor grounds to the IC ground should be used on the PC board. Resistors greater than  $10\Omega$  should be avoided as this can increase offset voltages at the CSP/CSN pins. The RC product should be kept to less than 30ns.

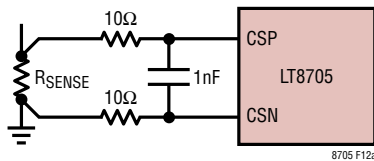

(12a)

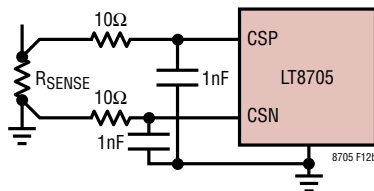

(12b)

Figure 12. Inductor Current Sense Filter

### Junction Temperature Measurement

The duty cycle of the CLKOUT signal is linearly proportional to the die junction temperature,  $T_J$ . Measure the duty cycle of the CLKOUT signal and use the following equation to approximate the junction temperature:

$$T_J \cong \frac{DC_{CLKOUT} - 35.9\%}{0.329\%} \text{ } ^\circ\text{C}$$

where  $DC_{CLKOUT}$  is the CLKOUT duty cycle in % and  $T_J$  is the die junction temperature in  $^\circ\text{C}$ . The actual die temperature can deviate from the above equation by  $\pm 10^\circ\text{C}$

### Thermal Shutdown

If the die junction temperature reaches approximately  $165^\circ\text{C}$ , the part will go into thermal shutdown. The power switch will be turned off and the INTV<sub>CC</sub> and LDO33 regulators will be turned off (see Figure 2). The part will be re-enabled when the die temperature has dropped by  $\sim 5^\circ\text{C}$  (nominal). After re-enabling, the part will start in the switcher off state as shown in Figure 2. The part will then initialize, perform a soft-start, then enter normal operation as long as the die temperature remains below approximately  $165^\circ\text{C}$ .

### Efficiency Considerations

The efficiency of a switching regulator is equal to the output power divided by the input power times 100%. It is often useful to analyze individual losses to determine what is limiting the efficiency and which change would produce the most improvement. Although all dissipative elements in the circuit produce losses, four main sources account for most of the losses in LT8705 circuits:

1. Switching losses. These losses arise from the brief amount of time switch M1 or switch M3 spends in the saturated region during switch node transitions. Power loss depends upon the input voltage, load current, driver strength and MOSFET capacitance, among other factors. See the Power MOSFET Selection and Efficiency Considerations section for more details.
2. DC  $I^2R$  losses. These arise from the resistances of the MOSFETs, sensing resistors, inductor and PC board traces and cause the efficiency to drop at high output currents.

## APPLICATIONS INFORMATION

3.  $I_{INTV_{CC}}$  current. This is the sum of the MOSFET driver current, LDO33 pin current and control currents. The  $I_{INTV_{CC}}$  regulator's input voltage times the current represents lost power. This loss can be reduced by supplying  $I_{INTV_{CC}}$  current through the  $EXTV_{CC}$  pin from a high efficiency source, such as the output or alternate supply if available. Also, lower capacitance MOSFETs can reduce  $I_{INTV_{CC}}$  current and power loss.
4.  $C_{IN}$  and  $C_{OUT}$  loss. The input capacitor has the difficult job of filtering the large RMS input current to the regulator in buck mode. The output capacitor has the more difficult job of filtering the large RMS output current in boost mode. Both  $C_{IN}$  and  $C_{OUT}$  are required to have low ESR to minimize the AC  $I^2R$  loss and sufficient capacitance to prevent the RMS current from causing additional upstream losses in fuses or batteries.
5. Other losses. Schottky diodes D1 and D2 are responsible for conduction losses during dead time and light load conduction periods. Inductor core loss occurs predominately at light loads.

When making adjustments to improve efficiency, the input current is the best indicator of changes in efficiency. If one makes a change and the input current decreases, then the efficiency has increased. If there is no change in input current, then there is no change in efficiency.

### Circuit Board Layout Checklist

The basic circuit board layout requires a dedicated ground plane layer. Also, for high current, a multilayer board provides heat sinking for power components.

- The ground plane layer should not have any traces and should be as close as possible to the layer with the power MOSFETs.
- The high di/dt path formed by switch M1, switch M2, D1,  $R_{SENSE}$  and the  $C_{IN}$  capacitor should be compact with short leads and PC trace lengths. The high di/dt path formed by switch M3, switch M4, D2 and the  $C_{OUT}$  capacitor also should be compact with short leads and PC trace lengths. Two layout examples are shown in Figures 13a and 13b.

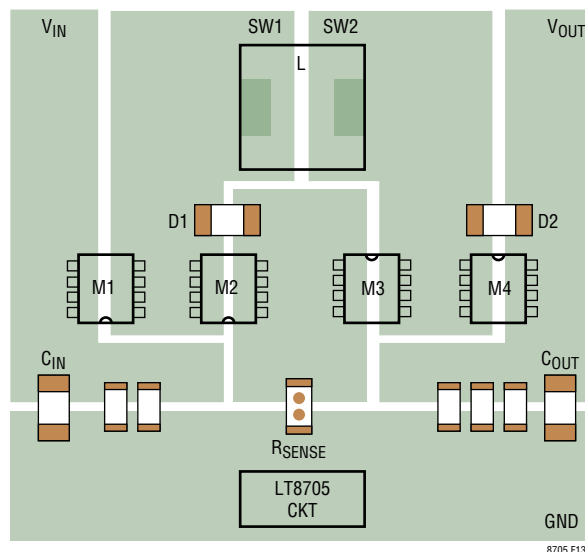

(13a)

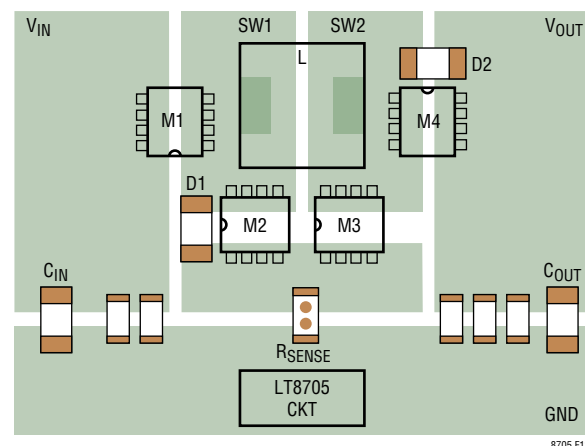

(13b)

Figure 13. Switches Layout

- Avoid running signal traces parallel to the traces that carry high di/dt current because they can receive inductively coupled voltage noise. This includes the SW1, SW2, TG1 and TG2 traces to the controller.
- Use immediate vias to connect the components (including the LT8705's GND pins) to the ground plane. Use several vias for each power component.
- Minimize parasitic SW pin capacitance by removing GND and  $V_{IN}$  copper from underneath the SW1 and SW2 regions.

## APPLICATIONS INFORMATION

- Except under the SW pin regions, flood all unused areas on all layers with copper. Flooding with copper will reduce the temperature rise of power components. Connect the copper areas to a DC net (e.g., quiet GND).
- Partition the power ground from the signal ground. The small-signal component grounds should not return to the IC GND through the power ground path.
- Place switch M2 and switch M3 as close to the controller as possible, keeping the GND, BG and SW traces short.
- Minimize inductance from the sources of M2 and M3 to R<sub>SENSE</sub> by making the trace short and wide.
- Keep the high dV/dT nodes SW1, SW2, BOOST1, BOOST2, TG1 and TG2 away from sensitive small-signal nodes.
- The output capacitor (–) terminals should be connected as closely as possible to the (–) terminals of the input capacitor.
- Connect the top driver boost capacitor, C<sub>B1</sub>, closely to the BOOST1 and SW1 pins. Connect the top driver boost capacitor, C<sub>B2</sub>, closely to the BOOST2 and SW2 pins.
- Connect the input capacitors, C<sub>IN</sub>, and output capacitors, C<sub>OUT</sub>, closely to the power MOSFETs. These capacitors carry the MOSFET AC current in the boost and buck regions.
- Connect the FBOUT and FBIN pin resistor dividers to the (+) terminals of C<sub>OUT</sub> and C<sub>IN</sub> respectively. Small FBOUT/FBIN bypass capacitors may be connected closely to the LT8705's GND pin if needed. The resistor connections should not be along the high current or noise paths.
- Route current sense traces (CSP/CSN, CSPIN/CSNIN, CSPOUT/CSNOUT) together with minimum PC trace spacing. Avoid having sense lines pass through noisy areas, such as switch nodes. The optional filter network capacitor between CSP and CSN should be as close as possible to the IC. Ensure accurate current sensing with Kelvin connections at the R<sub>SENSE</sub> resistors.
- Connect the V<sub>C</sub> pin compensation network closely to the IC, between V<sub>C</sub> and the signal ground pins. The capacitor helps to filter the effects of PCB noise and output voltage ripple voltage from the compensation loop.
- Connect the INTV<sub>CC</sub> and GATEV<sub>CC</sub> bypass capacitors close to the IC. The capacitors carry the MOSFET drivers' current peaks.

### Design Example

$$V_{IN} = 8V \text{ to } 25V$$

$$V_{OUT} = 12V$$

$$I_{OUT(MAX)} = 5A$$

$$f = 350kHz$$

$$\text{Maximum ambient temperature} = 60^{\circ}C$$

**R<sub>T</sub> Selection:** Choose the R<sub>T</sub> resistor for the free-running oscillator frequency using:

$$R_T = \left( \frac{43,750}{f_{OSC}} - 1 \right) k\Omega = \left( \frac{43,750}{350} - 1 \right) = 124k\Omega$$

**R<sub>SENSE</sub> Selection:** Start by calculating the maximum duty cycle in the boost region:

$$DC_{(MAX,M3,BOOST)} \cong \left( 1 - \frac{V_{IN(MIN)}}{V_{OUT(MAX)}} \right) \bullet 100\%$$

$$= \left( 1 - \frac{8V}{12V} \right) \bullet 100\% = 33\%$$

Next, from the Maximum Inductor Current Sense Voltage vs Duty Cycle graph in the Typical Performance Characteristics section:

$$V_{RSENSE(MAX,BOOST,MAX)} \cong 107mV$$

Next, estimate the maximum and minimum inductor current ripple in the boost and buck regions respectively:

$$\Delta I_{L(MAX,BOOST)} \cong \frac{V_{OUT(MAX)} \bullet I_{OUT(MAX,BOOST)}}{V_{IN(MIN)} \bullet \left( \frac{100\%}{\%Ripple} - 0.5 \right)}$$

$$= \frac{12V \bullet 5A}{8V \bullet \left( \frac{100\%}{40\%} - 0.5 \right)} = 3.75A$$

$$\Delta I_{L(MIN,BUCK)} \cong \frac{I_{OUT(MAX,BUCK)}}{\left( \frac{100\%}{10\%} - 0.5 \right)} A$$

$$= \frac{5A}{\left( \frac{100\%}{10\%} - 0.5 \right)} = 0.53A$$

Now calculate the maximum R<sub>SENSE</sub> values in the boost and buck regions to be:

## APPLICATIONS INFORMATION

$$R_{\text{SENSE(MAX,BOOST)}} = \frac{2 \cdot V_{\text{RSENSE(MAX,BOOST,MAX)}} \cdot V_{\text{IN(MIN)}}}{(2 \cdot I_{\text{OUT(MAX,BOOST)}} \cdot V_{\text{OUT(MIN)}}) + (\Delta I_{\text{L(MAX,BOOST)}} \cdot V_{\text{IN(MIN)}})} \Omega$$

$$= \frac{2 \cdot 107\text{mV} \cdot 8\text{V}}{(2 \cdot 5\text{A} \cdot 12\text{V}) + (3.75\text{A} \cdot 8\text{V})} = 11.4\text{m}\Omega$$

$$R_{\text{SENSE(MAX,BUCK)}} = \frac{2 \cdot 86\text{mV}}{(2 \cdot I_{\text{OUT(MAX,BUCK)}}) - \Delta I_{\text{L(MIN,BUCK)}}} \Omega$$

$$= \frac{2 \cdot 86\text{mV}}{(2 \cdot 5\text{A}) - 0.53\text{A}} = 18.2\text{m}\Omega$$

Adding an additional 30% margin, choose  $R_{\text{SENSE}}$  to be  $11.4\text{m}\Omega / 1.3 = 8.7\text{m}\Omega$ .

**Inductor Selection:** With  $R_{\text{SENSE}}$  known, we can now determine the minimum inductor value that will provide adequate load current in the boost region using:

$$L_{\text{(MIN1,BOOST)}} \cong \frac{V_{\text{IN(MIN)}} \cdot \frac{\text{DC}_{\text{(MAX,M3,BOOST)}}}{100\%}}{2 \cdot f \cdot \left( \frac{V_{\text{RSENSE(MAX,BOOST,MAX)}}}{R_{\text{SENSE}}} - \frac{I_{\text{OUT(MAX)}} \cdot V_{\text{OUT(MAX)}}}{V_{\text{IN(MIN)}}} \right)} \text{H}$$

$$= \frac{8\text{V} \cdot \left( \frac{33\%}{100\%} \right)}{2 \cdot 350\text{kHz} \cdot \left( \frac{107\text{mV}}{8.7\text{m}\Omega} - \frac{5\text{A} \cdot 12\text{V}}{8\text{V}} \right)} = 0.8\mu\text{H}$$

To avoid subharmonic oscillations in the inductor current, choose the minimum inductance according to:

$$L_{\text{(MIN2,BOOST)}} = \frac{\left[ V_{\text{OUT(MAX)}} - \left( \frac{V_{\text{IN(MIN)}} \cdot V_{\text{OUT(MAX)}}}{V_{\text{OUT(MAX)}} - V_{\text{IN(MIN)}}} \right) \right] \cdot R_{\text{SENSE}}}{0.08 \cdot f} \text{H}$$

$$= \frac{\left[ 12\text{V} - \left( \frac{8\text{V} \cdot 12\text{V}}{12\text{V} - 8\text{V}} \right) \right] \cdot 8.7\text{m}\Omega}{0.08 \cdot 350\text{kHz}} = -3.7\mu\text{H}$$

$$L_{\text{(MIN1,BUCK)}} = \frac{V_{\text{IN(MAX)}} \cdot \left( 1 - \frac{V_{\text{OUT(MAX)}}}{V_{\text{IN(MAX)}} - V_{\text{OUT(MIN)}}} \right) \cdot R_{\text{SENSE}}}{0.08 \cdot f}$$

$$= \frac{25\text{V} \cdot \left( 1 - \frac{12\text{V}}{25\text{V} - 12\text{V}} \right) \cdot 8.7\text{m}\Omega}{0.08 \cdot 350\text{kHz}} = 0.6\mu\text{H}$$

The inductance must be higher than all of the minimum values calculated above. We will choose a  $10\mu\text{H}$  standard value inductor for improved margin.

**MOSFET Selection:** The MOSFETs are selected based on voltage rating,  $C_{\text{RSS}}$  and  $R_{\text{DS(ON)}}$  value. It is important to ensure that the part is specified for operation with the available gate voltage amplitude. In this case, the amplitude is  $6.35\text{V}$  and MOSFETs with an  $R_{\text{DS(ON)}}$  value specified at  $V_{\text{GS}} = 4.5\text{V}$  can be used.

**Select M1 and M2:** With  $25\text{V}$  maximum input voltage, MOSFETs with a rating of at least  $30\text{V}$  are used. As we do not yet know the actual thermal resistance (circuit board design and airflow have a major impact) we assume that the MOSFET thermal resistance from junction to ambient is  $50^\circ\text{C/W}$ .

If we design for a maximum junction temperature,  $T_{\text{J(MAX)}} = 125^\circ\text{C}$ , the maximum allowable power dissipation can be calculated. First, calculate the maximum power dissipation:

$$P_{\text{D(MAX)}} = \frac{T_{\text{J(MAX)}} - T_{\text{A(MAX)}}}{R_{\text{TH(JA)}}}$$

$$P_{\text{D(MAX)}} = \frac{125^\circ\text{C} - 60^\circ\text{C}}{50^\circ\text{C/W}} = 1.3\text{W}$$

Since maximum  $I^2R$  power dissipation in the boost region happens when  $V_{\text{IN}}$  is minimum, we can determine the maximum allowable  $R_{\text{DS(ON)}}$  for the boost region using:

$$P_{\text{M1}} = P_{\text{I}^2\text{R}} \cong \left[ \left( \frac{V_{\text{OUT}}}{V_{\text{IN}}} \cdot I_{\text{OUT}} \right)^2 \cdot R_{\text{DS(ON)}} \cdot P_{\tau} \right] \text{W}$$

$$1.3\text{W} \cong \left[ \left( \frac{12\text{V}}{8\text{V}} \cdot 5\text{A} \right)^2 \cdot R_{\text{DS(ON)}} \cdot 1.5 \right] \text{W} \text{ and therefore}$$

$$R_{\text{DS(ON)}} < 15.4\text{m}\Omega$$

The Fairchild FDMS7672 meets the specifications with a maximum  $R_{\text{DS(ON)}}$  of  $\sim 6.9\text{m}\Omega$  at  $V_{\text{GS}} = 4.5\text{V}$  ( $\sim 10\text{m}\Omega$  at  $125^\circ\text{C}$ ). Checking the power dissipation in the buck region with  $V_{\text{IN}}$  maximum and  $V_{\text{OUT}}$  minimum yields:

## APPLICATIONS INFORMATION

$$P_{M1} = P_{1R}^2 + P_{SWITCHING}$$

$$\cong \left( \frac{V_{OUT}}{V_{IN}} \cdot I_{OUT}^2 \cdot R_{DS(ON)} \cdot \rho_{\tau} \right) + (V_{IN} \cdot I_{OUT} \cdot f \cdot t_{RF1}) W$$

$$P_{M1} \cong \left( \frac{12V}{25V} \cdot 5A^2 \cdot 6.9m\Omega \cdot 1.5 \right) + (25V \cdot 5A \cdot 350k \cdot 20ns)$$

$$= 0.12W + 0.88W = 1.0W$$

The maximum switching power of 0.88W can be reduced by choosing a slower switching frequency. Since this calculation is approximate, measure the actual rise and fall times on the PCB to obtain a better power estimate.

The maximum dissipation in M2 occurs at maximum input voltage when the circuit is operating in the buck region. Using the 6.9mΩ Fairchild FDMS7672 the dissipation is:

$$P_{(M2,BUCK)} \cong \left( \frac{V_{IN} - V_{OUT}}{V_{IN}} \cdot I_{OUT(MAX)}^2 \cdot R_{DS(ON)} \cdot \rho_{\tau} \right) W$$

$$P_{(M2,BUCK)} \cong \left( \frac{25V - 12V}{25V} \cdot (5A)^2 \cdot 6.9m\Omega \cdot 1.5 \right) = 0.13W$$

**Select M3 and M4:** With 12V output voltage we need MOSFETs with 20V or higher rating.

The highest dissipation occurs in the boost region when input voltage is minimum and output current is highest. For switch M3 the dissipation is:

$$P_{M3} = P_{1R}^2 + P_{SWITCHING} \cong$$

$$\left( \frac{(V_{OUT} - V_{IN}) \cdot V_{OUT}}{V_{IN}^2} \cdot I_{OUT}^2 \cdot R_{DS(ON)} \cdot \rho_{\tau} \right)$$

$$+ \left( V_{OUT}^2 \cdot I_{OUT} \cdot f \cdot \frac{t_{RF2}}{V_{IN}} \right) W$$

as described in the Power MOSFET Selection and Efficiency Considerations section.

The maximum dissipation in switch M4 is:

$$P_{(M4,BOOST)} \cong \left( \frac{V_{OUT(MAX)}}{V_{IN(MIN)}} \cdot I_{OUT}^2 \cdot \rho_{\tau} \cdot R_{DS(ON)} \right) W$$

The Fairchild FDMS7672 can also be used for M3 and M4. Assuming 20ns rise and fall times, the calculated power loss at the minimum 8V input voltage is then 0.82W for M3 and 0.39W for M4

**Output Voltage:** Output voltage is 12V. Select R<sub>FBOUT2</sub> as 20k. R<sub>FBOUT1</sub> is:

$$R_{FBOUT1} = \left( \frac{V_{OUT}}{1.207V} - 1 \right) \cdot R_{FBOUT2}$$

Select R<sub>FBOUT1</sub> as 178k. Both R<sub>FBOUT1</sub> and R<sub>FBOUT2</sub> should have a tolerance of no more than 1%.

**Capacitors:** A low ESR (5mΩ) capacitor network for C<sub>IN</sub> is selected. In this mode, the maximum ripple is:

$$\Delta V_{(BUCK,ESR)} \cong \frac{V_{IN(MAX)} \cdot I_{OUT(MAX)} \cdot ESR}{V_{OUT(MIN)}}$$

$$\Delta V_{(BUCK,ESR)} \cong \frac{25V \cdot 5A}{12V} \cdot 5m\Omega = 52mV$$

assuming ESR dominates the ripple.

Having 5mΩ of ESR for the C<sub>OUT</sub> network sets the maximum output voltage ripple at:

$$\Delta V_{(BOOST,ESR)} \cong \frac{V_{OUT(MAX)} \cdot I_{OUT(MAX)} \cdot ESR}{V_{IN(MIN)}}$$

$$\Delta V_{(BOOST,ESR)} \cong \frac{12V \cdot 5A}{8V} \cdot 5m\Omega = 37.5mV$$

assuming ESR dominates the ripple.

APPLICATIONS INFORMATION

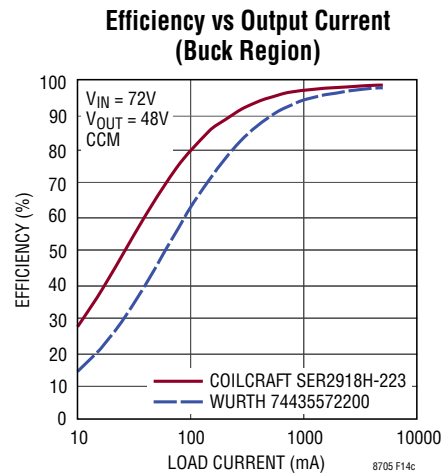
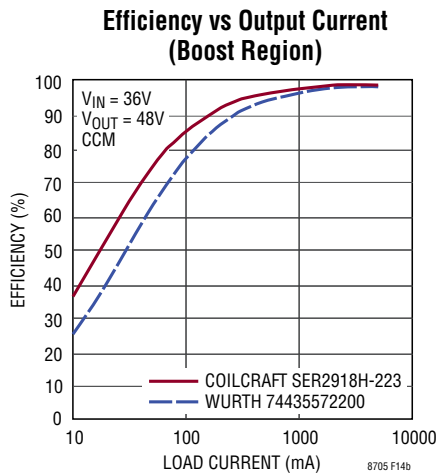
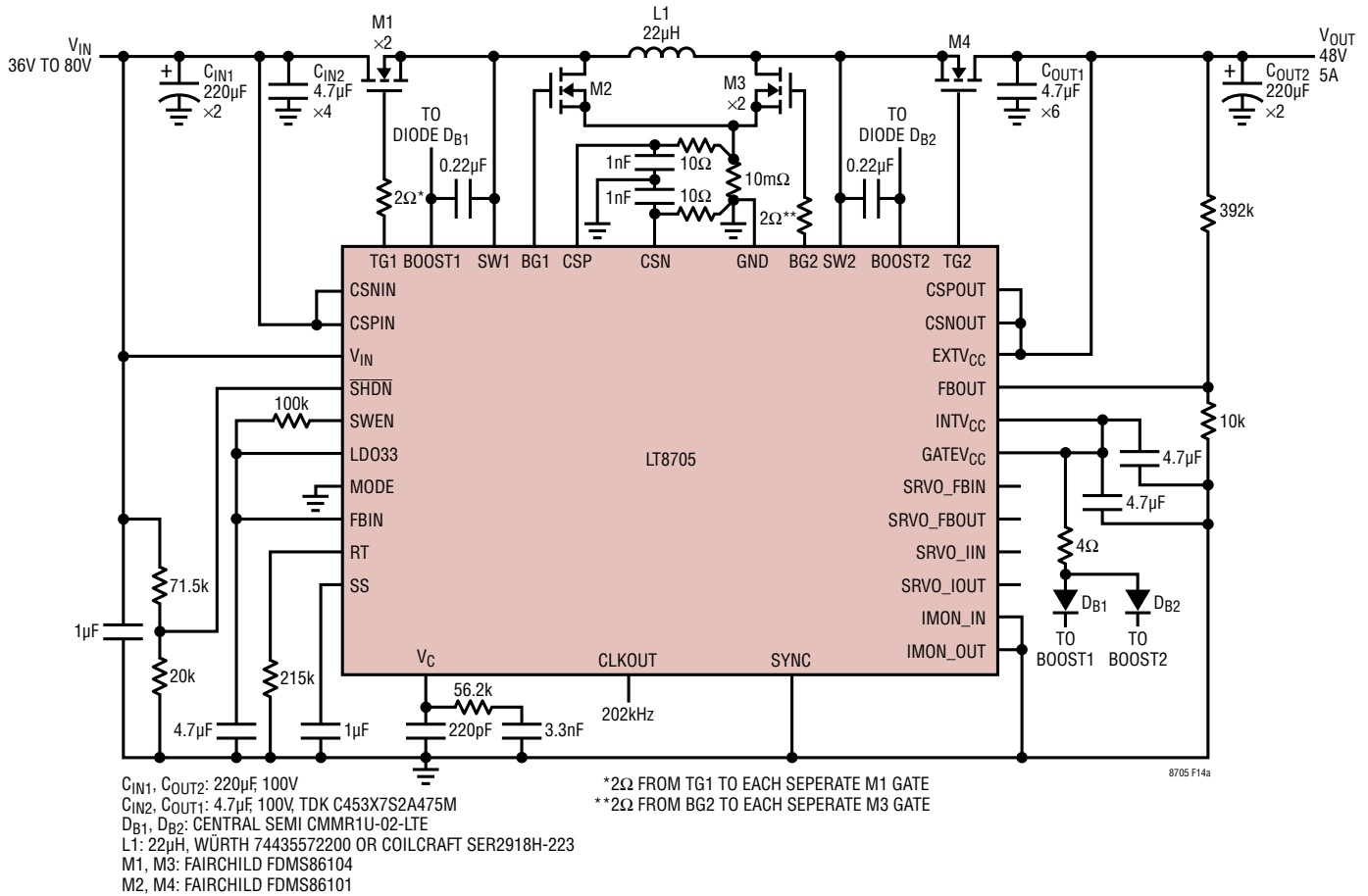

Note: See the front page and the Typical Performance Characteristics section for more curves from this application circuit using the Coilcraft inductor. The smaller Würth inductor is also suitable in place of the Coilcraft inductor with some loss in efficiency.

Figure 14. Telecom Voltage Stabilizer

TYPICAL APPLICATIONS

Supercapacitor Backup Supply

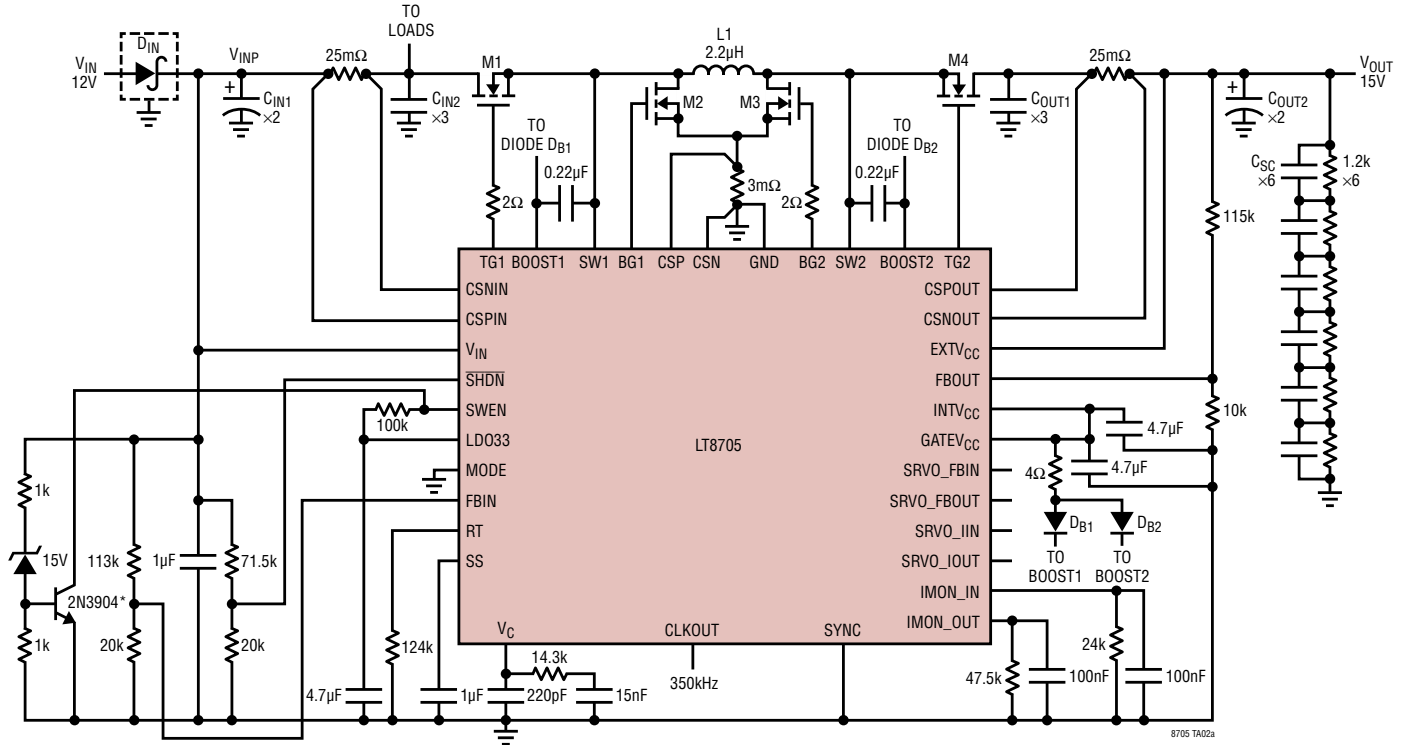

C<sub>IN1</sub>, C<sub>OUT2</sub>: 100µF, 20V SANYO OS-CON 205A100M  
 C<sub>IN2</sub>, C<sub>OUT1</sub>: 22µF, 25V, TDK C4532X741E226M  
 C<sub>SC</sub>: 60F 2.5V COOPER BUSSMAN HB1840-2R5606-R

D<sub>IN</sub>: APPROPRIATE 2A SCHOTTKY DIODE OR IDEAL DIODE SUCH AS LTC4358, LTC4412, LTC4352, ETC.  
 D<sub>B1</sub>, D<sub>B2</sub>: CENTRAL SEMI CMMR1U-02-LTE  
 L1: 2.2µH, VISHAY IHLP-5050CE-01-2R2-M-01  
 M1-M4: FAIRCHILD FDMS7698

\* INPUT SIDE OVERVOLTAGE PROTECTION WHEN CONVERTER IS DRAWING CURRENT FROM THE SUPER CAPACITORS

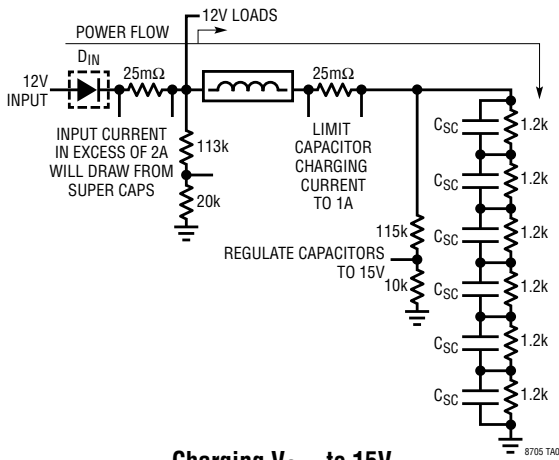

Charging V<sub>OUT</sub> to 15V with 1A Current

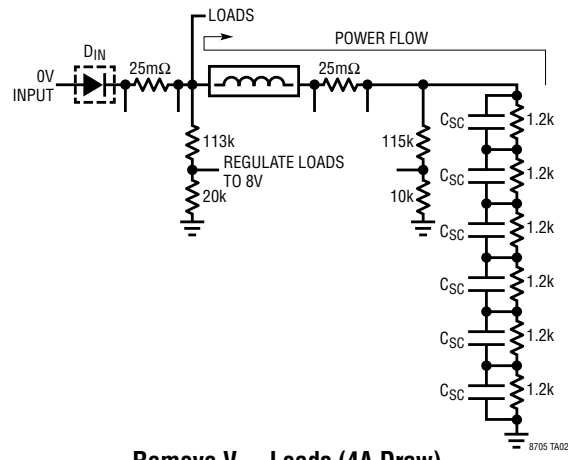
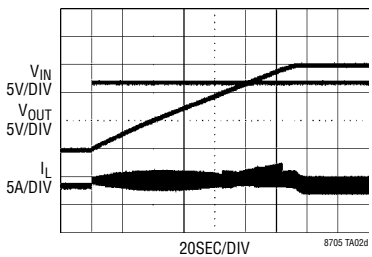

Remove V<sub>IN</sub>. Loads (4A Draw) Regulated to 8V from Supercaps

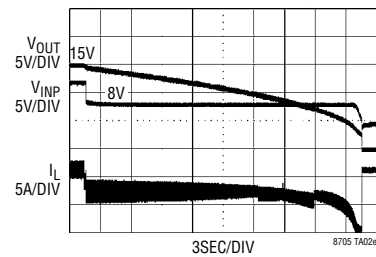

# PACKAGE DESCRIPTION

Please refer to <http://www.linear.com/designtools/packaging/> for the most recent package drawings.

**UHF Package**  
**38-Lead Plastic QFN (5mm × 7mm)**  
 (Reference LTC DWG # 05-08-1701 Rev C)

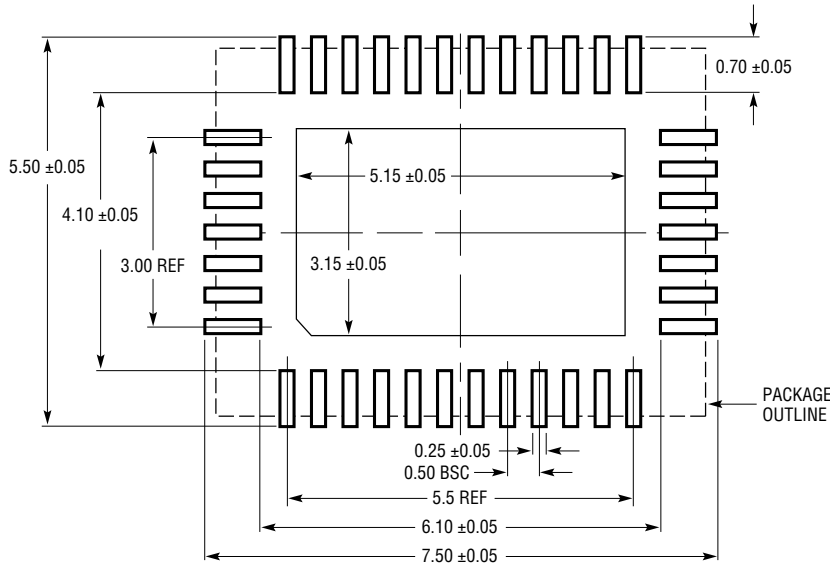

RECOMMENDED SOLDER PAD LAYOUT  
 APPLY SOLDER MASK TO AREAS THAT ARE NOT SOLDERED

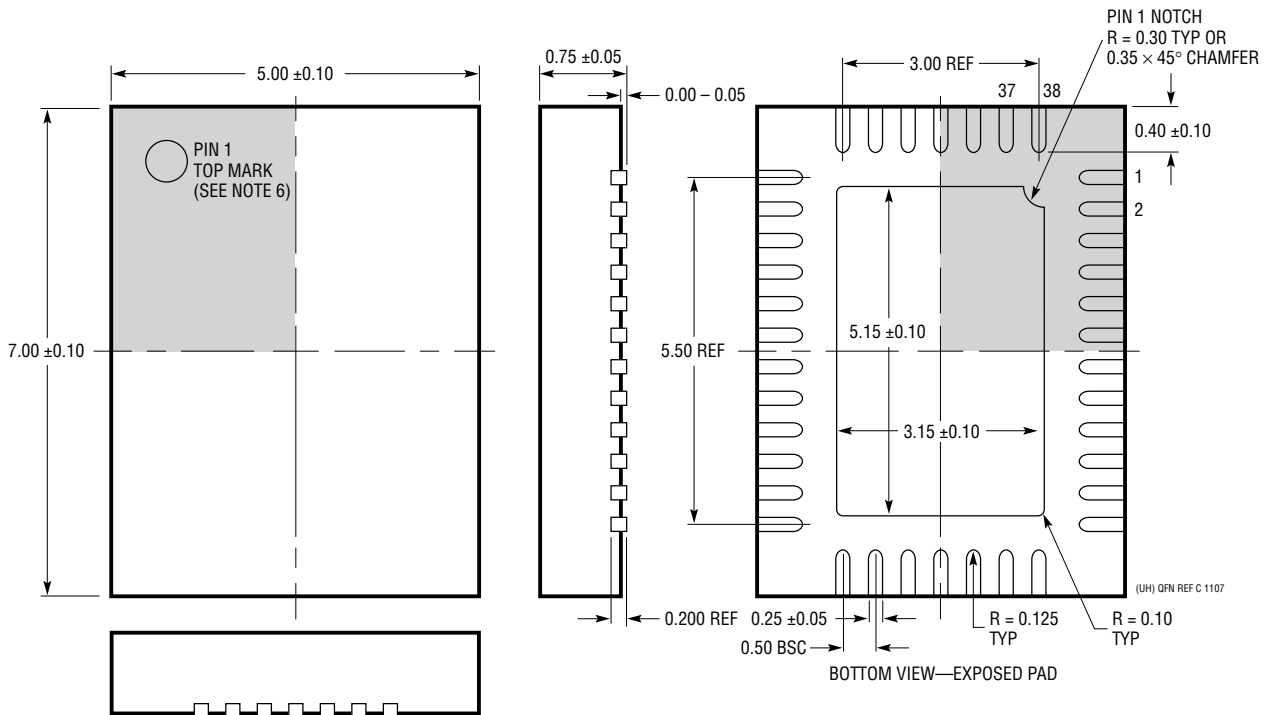

- NOTE:
1. DRAWING CONFORMS TO JEDEC PACKAGE OUTLINE M0-220 VARIATION WHKD
  2. DRAWING NOT TO SCALE
  3. ALL DIMENSIONS ARE IN MILLIMETERS

4. DIMENSIONS OF EXPOSED PAD ON BOTTOM OF PACKAGE DO NOT INCLUDE MOLD FLASH. MOLD FLASH, IF PRESENT, SHALL NOT EXCEED 0.20mm ON ANY SIDE
5. EXPOSED PAD SHALL BE SOLDER PLATED
6. SHADED AREA IS ONLY A REFERENCE FOR PIN 1 LOCATION ON THE TOP AND BOTTOM OF PACKAGE

# PACKAGE DESCRIPTION

Please refer to <http://www.linear.com/designtools/packaging/> for the most recent package drawings.

**FE Package**  
**Package Variation: FE38 (31)**  
**38-Lead Plastic TSSOP (4.4mm)**  
 (Reference LTC DWG # 05-08-1865 Rev B)  
**Exposed Pad Variation AB**

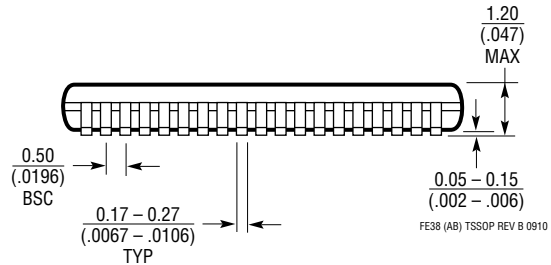
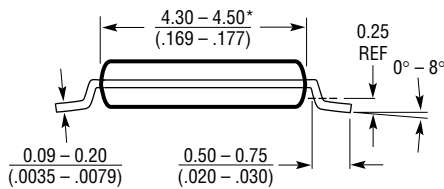
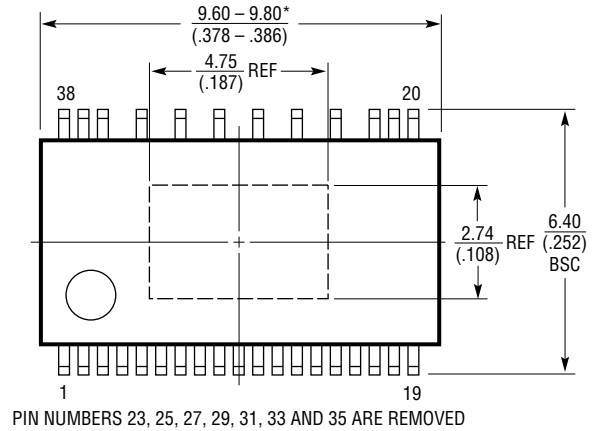
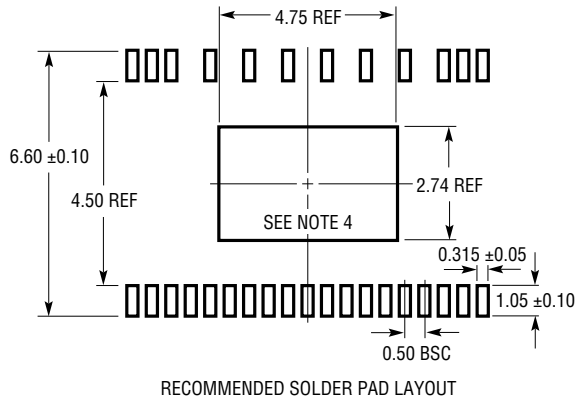

- NOTE:
1. CONTROLLING DIMENSION: MILLIMETERS
  2. DIMENSIONS ARE IN MILLIMETERS (INCHES)
  3. DRAWING NOT TO SCALE
  4. RECOMMENDED MINIMUM PCB METAL SIZE FOR EXPOSED PAD ATTACHMENT  
 \*DIMENSIONS DO NOT INCLUDE MOLD FLASH. MOLD FLASH SHALL NOT EXCEED 0.150mm (.006") PER SIDE

## REVISION HISTORY

REV	DATE	DESCRIPTION	PAGE NUMBER
A	12/13	Changed 0.4V to 0.35V under Start-Up paragraph	14
		Changed 9m $\Omega$ resistor value to 10m $\Omega$	39
		Added 1k $\Omega$ resistor in series with 15V Zener	40
B	02/14	Added "Not Switching" to Line Regulation conditions, two places	4
		Changed C <sub>OUT2</sub> and C <sub>OUT3</sub>	44
C	07/14	Added H- and MP-grades	2, 3, 4, 5, 6, 14
D	02/15	Corrected MP-grade part number	3
E	06/15	Modified P <sub>M1</sub> equation	38
F	09/15	Added P <sub>M1</sub> Boost Region Equation	26
		Modified P <sub>(M4,BOOST)</sub> Equation	27



## Looking for pricing, stock, or lifecycle information?

Click below to explore more details on WIN SOURCE:

 [View LT8705EFE#PBF on WIN SOURCE](#)

 [Linear Technology](#) Information

## Optimize Your Supply Chain with WIN SOURCE Solutions

-  Global Sourcing Solution
-  Obsolete Management
-  Cost Control Management
-  Shortage Management
-  Alternative Solution
-  Excess Inventory Management