



**THE DATASHEET OF
SN65HVD20P**



SN65HVD2x Extended Common-Mode RS-485 Transceivers

1 Features

- Common-Mode Voltage Range (–20 V to 25 V) More Than Doubles TIA/EIA-485 Requirement
- Receiver Equalization Extends Cable Length, Signaling Rate (SN65HVD2[3,4])
- Reduced Unit-Load for up to 256 Nodes
- Bus I/O Protection to Over 16-kV HBM
- Failsafe Receiver for Open-Circuit, Short-Circuit, and Idle-Bus Conditions
- Low Standby Supply Current 1 μ A (Maximum)
- More Than 100 mV Receiver Hysteresis

2 Applications

- Long Cable Solutions
 - Factory Automation
 - Security Networks
 - Building HVAC
- Severe Electrical Environments
 - Electrical Power Inverters
 - Industrial Drives
 - Avionics

3 Description

The transceivers in the SN65HVD2x family offer performance far exceeding typical RS-485 devices. In addition to meeting all requirements of the TIA/EIA-485-A standard. The SN65HVD2x family operates over an extended range of common-mode voltages and has features such as high ESD protection, wide receiver hysteresis, and failsafe operation. This family of devices is ideally suited for long-cable networks and other applications where the environment is too harsh for ordinary transceivers.

These devices are designed for bidirectional data transmission on multipoint twisted-pair cables. Example applications are digital motor controllers, remote sensors and terminals, industrial process control, security stations, and environmental control systems.

These devices combine a 3-state differential driver and a differential receiver that operate from a single 5-V power supply. The driver differential outputs and the receiver differential inputs are connected internally to form a differential bus port that offers minimum loading to the bus. This port features an extended common-mode voltage range, making the device suitable for multipoint applications over long cable runs.

Device Information⁽¹⁾

PART NUMBER	PACKAGE	BODY SIZE (NOM)
SN65HVD2x	SOIC (8)	4.90 mm x 3.91 mm
	PDIP (8)	9.81 mm x 6.35 mm

(1) For all available packages, see the orderable addendum at the end of the data sheet.

SN65HVD2x Application Space

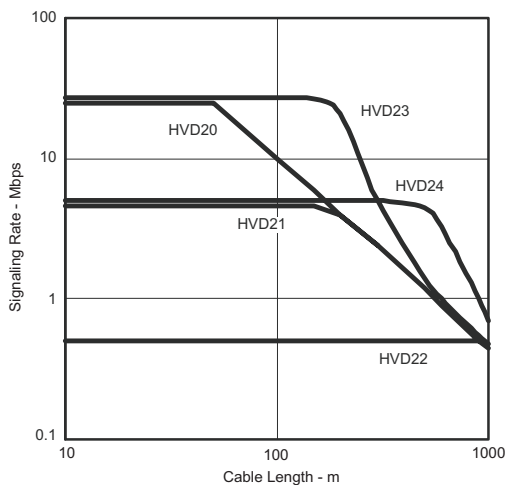

SN65HVD2x Devices Operate Over a Wider Common-Mode Voltage Range

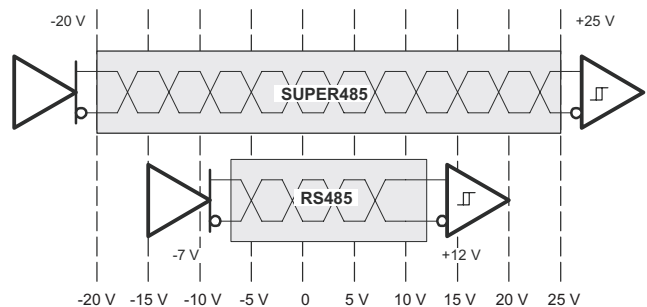

Table of Contents

1 Features	1	10 Detailed Description	17
2 Applications	1	10.1 Overview	17
3 Description	1	10.2 Functional Block Diagram	17
4 Revision History	2	10.3 Feature Description	17
5 Description (continued)	4	10.4 Device Functional Modes	19
6 Device Options	4	11 Application and Implementation	22
7 Pin Configuration and Functions	5	11.1 Application Information	22
8 Specifications	5	11.2 Typical Application	22
8.1 Absolute Maximum Ratings	5	12 Power Supply Recommendations	24
8.2 ESD Ratings	6	13 Layout	24
8.3 Recommended Operating Conditions	6	13.1 Layout Guidelines	24
8.4 Thermal Information	7	13.2 Layout Example	25
8.5 Driver Electrical Characteristics	7	14 Device and Documentation Support	26
8.6 Receiver Electrical Characteristics	8	14.1 Related Links	26
8.7 Driver Switching Characteristics	8	14.2 Receiving Notification of Documentation Updates	26
8.8 Receiver Switching Characteristics	9	14.3 Community Resources	26
8.9 Receiver Equalization Characteristics	9	14.4 Trademarks	26
8.10 Power Dissipation	10	14.5 Electrostatic Discharge Caution	26
8.11 Typical Characteristics	11	14.6 Glossary	26
9 Parameter Measurement Information	12	15 Mechanical, Packaging, and Orderable Information	26

4 Revision History

NOTE: Page numbers for previous revisions may differ from page numbers in the current version.

Changes from Revision E (May 2010) to Revision F	Page
• Added ESD Ratings table, Feature Description section, Device Functional Modes, Application and Implementation section, Power Supply Recommendations section, Layout section, Device and Documentation Support section, and Mechanical, Packaging, and Orderable Information section.	1
• Deleted Ordering Information table; see POA at the end of the data sheet	1
• Added maximum temperature value (150°C) to "Storage temperature, T_{stg} parameter	5

Changes from Revision D (April 2005) to Revision E	Page
• Replaced the Dissipation Rating table with the THERMAL INFORMATION table	7
• Changed I_O - Added test condition and values per device number (DRIVER ELECTRICAL CHARACTERISTICS table) ...	7
• Changed the THERMAL CHARACTERISTICS table to POWER DISSIPATION table	10
• Added the TEST MODE DRIVER DISABLE section	20

Changes from Revision C (September 2003) to Revision D	Page
• Added Conditions note to the ABSOLUTE MAXIMUM RATINGS table "over operating free-air temperature range (unless otherwise noted)"	5
• Deleted Storage temperature, T_{stg} from the ABSOLUTE MAXIMUM RATINGS table	5
• Added Receiver output current, I_O to the ABSOLUTE MAXIMUM RATINGS table	5

Changes from Revision B (June 2003) to Revision C	Page
• Added the THERMAL CHARACTERISTICS table	7
• Added the THEORY OF OPERATION section	17
• Added the NOISE CONSIDERATIONS FOR EQUALIZED RECEIVERS section	22

Changes from Revision A (March 2003) to Revision B	Page
• Added V_{IK} Typical Value of 0.75 V (DRIVER ELECTRICAL CHARACTERISTICS table)	7
• Deleted $V_{IT(F+)} - V_{CM} = -20$ V to 25 V Minimum value (RECEIVER ELECTRICAL CHARACTERISTICS table)	8
• Added RECEIVER EQUALIZATION CHARACTERISTICS table.....	9
• Added Figure 6 , Figure 7 , and Figure 8 to the TYPICAL CHARACTERISTICS	11
• Changed A Input circuit in the EQUIVALENT INPUT AND OUTPUT SCHEMATIC DIAGRAMS	21
• Changed the INTEGRATED RECEIVER EQUALIZATION USING THE SN65HVD23 section	23

Changes from Original (December 2002) to Revision A	Page
• Changed t_{PZH} , t_{PHZ} , t_{PZL} , and t_{PLZ} - From a maximum value of 120 to include typical and maximum values for each entry (RECEIVER SWITCHING CHARACTERISTICS table)	9

5 Description (continued)

The SN65HVD20 device provides high signaling rate (up to 25 Mbps) for interconnecting networks of up to 64 nodes.

The SN65HVD21 device allows up to 256 connected nodes at moderate data rates (up to 5 Mbps). The driver output slew rate is controlled to provide reliable switching with shaped transitions which reduce high-frequency noise emissions.

The SN65HVD22 device has controlled driver output slew rate for low radiated noise in emission-sensitive applications and for improved signal quality with long stubs. Up to 256 SN65HVD22 nodes can be connected at signaling rates up to 500 kbps.

The SN65HVD23 device implements receiver equalization technology for improved jitter performance on differential bus applications with data rates up to 25 Mbps at cable lengths up to 160 meters.

The SN65HVD24 device implements receiver equalization technology for improved jitter performance on differential bus applications with data rates from 1 Mbps to 10 Mbps at cable lengths up to 1000 meters.

The receivers include a failsafe circuit that provides a high-level output within 250 microseconds after loss of the input signal. The most common causes of signal loss are disconnected cables, shorted lines, or the absence of any active transmitters on the bus. This feature prevents noise from being received as valid data under these fault conditions. This feature may be used for Wired-OR bus signaling.

The SN65HVD2x devices are characterized for operation temperatures from –40°C to 85°C.

6 Device Options

Table 1. Product Selection Guide

PART NUMBERS	CABLE LENGTH AND SIGNALING RATE ⁽¹⁾	NODES	MARKING
SN65HVD20	Up to 50 m at 25 Mbps	Up to 64	D: VP20, P: 65HVD20
SN65HVD21	Up to 150 m at 5 Mbps (with slew rate limit)	Up to 256	D: VP21, P: 65HVD21
SN65HVD22	Up to 1200 m at 500 kbps (with slew rate limit)	Up to 256	D: VP22, P: 65HVD22
SN65HVD23	Up to 160 m at 25 Mbps (with receiver equalization)	Up to 64	D: VP23, P: 65HVD23
SN65HVD24	Up to 500 m at 3 Mbps (with receiver equalization)	Up to 256	D: VP24, P: 65HVD24

(1) Distance and signaling rate predictions based upon Belden 3105A cable and 15% eye pattern jitter.

Table 2. Available Options

PLASTIC THROUGH-HOLE P-PACKAGE (JEDEC MS-001)	PLASTIC SMALL-OUTLINE ⁽¹⁾ D-PACKAGE (JEDEC MS-012)
SN65HVD20P	SN65HVD20D
SN65HVD21P	SN65HVD21D
SN65HVD22P	SN65HVD22D
SN65HVD23P	SN65HVD23D
SN65HVD24P	SN65HVD24D

(1) Add R suffix for taped and reeled carriers.

7 Pin Configuration and Functions

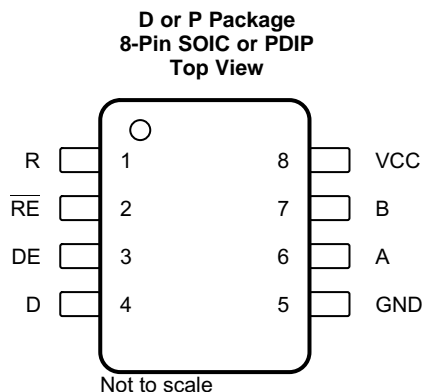

Pin Functions

PIN		I/O	DESCRIPTION
NAME	NO.		
A	6	Bus input and output	Driver output or receiver input (complementary to B)
B	7	Bus input and output	Driver output or receiver input (complementary to A)
D	4	Digital input	Driver data input
DE	3	Digital input	Driver enable, active high
GND	5	Reference potential	Local device ground
R	1	Digital output	Receive data output
\overline{RE}	2	Digital input	Receiver enable, active low
VCC	8	Supply	4.5-V to 5.5-V supply

8 Specifications

8.1 Absolute Maximum Ratings

over operating free-air temperature range (unless otherwise noted) ⁽¹⁾

	MIN	MAX	UNIT
Supply voltage ⁽²⁾	-0.5	7	V
Voltage at any bus I/O terminal	-27	27	V
Voltage input, transient pulse	A, B	(through 100 Ω , see Figure 24)	-60 60 V
Voltage input	D, DE, \overline{RE}	-0.5 $V_{CC} + 0.5$	V
Receiver output current	-10	10	mA
Continuous total power dissipation	See Power Dissipation		
Junction temperature, T_J		150	°C
Storage temperature, T_{stg}		150	°C

- (1) Stresses beyond those listed under *Absolute Maximum Ratings* may cause permanent damage to the device. These are stress ratings only, which do not imply functional operation of the device at these or any other conditions beyond those indicated under *Recommended Operating Conditions*. Exposure to absolute-maximum-rated conditions for extended periods may affect device reliability.
- (2) All voltage values, except differential I/O bus voltages, are with respect to network ground terminal.

8.2 ESD Ratings

			VALUE	UNIT	
$V_{(ESD)}$	Electrostatic discharge	Human-body model (HBM), per ANSI/ESDA/JEDEC JS-001 ⁽¹⁾	All pins except 5, 6, and 7	±5000	V
			Pins 5, 6, and 7	±16000	
		Charged-device model (CDM), per JEDEC specification JESD22-C101 ⁽²⁾		±1500	
			Machine Model (MM) ⁽³⁾	±200	

(1) Tested in accordance with JEDEC Standard 22, Test Method A114-A.

(2) Tested in accordance with JEDEC Standard 22, Test Method C101.

(3) Tested in accordance with JEDEC Standard 22, Test Method A115-A.

8.3 Recommended Operating Conditions

			MIN	NOM	MAX	UNIT
V_{CC}	Supply voltage		4.5	5	5.5	V
	Voltage at any bus I/O terminal	A, B	-20		25	V
V_{IH}	High-level input voltage	D, DE, \overline{RE}	2		V_{CC}	V
V_{IL}	Low-level input voltage		0		0.8	V
V_{ID}	Differential input voltage	A with respect to B	-25		25	V
	Output current	Driver	-110		110	mA
		Receiver	-8		8	
I_{CC}	Supply current	Driver enabled (DE at V_{CC}), Receiver enabled (RE at 0 V), No load, $V_I = 0$ V or V_{CC}	SN65HVD20	6	9	mA
			SN65HVD21	8	12	
			SN65HVD22	6	9	
			SN65HVD23	7	11	
			SN65HVD24	10	14	
		Driver enabled (DE at V_{CC}), Receiver disabled (RE at V_{CC}), No load, $V_I = 0$ V or V_{CC}	SN65HVD20	5	8	
			SN65HVD21	7	11	
			SN65HVD22	5	8	
			SN65HVD23	5	9	
		Driver disabled (DE at 0 V), Receiver enabled (RE at 0 V), No load	SN65HVD24	8	12	
			SN65HVD20	4	7	
			SN65HVD21	5	8	
			SN65HVD22	4	7	
		Driver disabled (DE at 0 V), Receiver disabled (RE at V_{CC}) D open	SN65HVD23	4.5	9	
			SN65HVD24	5.5	10	
				All SN65HVD2x		
T_A	Operating free-air temperature ⁽¹⁾		-40		85	°C
T_J	Junction temperature		-40		130	°C

(1) Maximum free-air temperature operation is allowed as long as the device recommended junction temperature is not exceeded.

8.4 Thermal Information

THERMAL METRIC ⁽¹⁾		SN65HVD2x		UNIT
		D (SOIC)	P (PDIP)	
		8 PINS	8 PINS	
$R_{\theta JA}$	Junction-to-ambient thermal resistance	78.1	52.5	°C/W
$R_{\theta JC(top)}$	Junction-to-case(top) thermal resistance	56.5	57.6	°C/W
$R_{\theta JB}$	Junction-to-board thermal resistance	50.4	38.6	°C/W
Ψ_{JT}	Junction-to-top characterization parameter	4.1	19.1	°C/W
Ψ_{JB}	Junction-to-board characterization parameter	32.6	31.9	°C/W

- (1) For more information about traditional and new thermal metrics, see the [Semiconductor and IC Package Thermal Metrics](#) application report.

8.5 Driver Electrical Characteristics

over recommended operating conditions (unless otherwise noted).⁽¹⁾

PARAMETER		TEST CONDITIONS	MIN	TYP	MAX	UNIT	
V_{IK}	Input clamp voltage	$I_I = -18$ mA	-1.5	0.75		V	
V_O	Open-circuit output voltage	A or B, No load	0		V_{CC}	V	
$ V_{OD(SS)} $	Steady-state differential output voltage	No load (open circuit)	3.3	4.2	V_{CC}	V	
		$R_L = 54$ Ω , See Figure 9	1.8	2.5			
		With common-mode loading, See Figure 10	1.8				
$\Delta V_{OD(SS)} $	Change in steady-state differential output voltage between logic states	See Figure 9 and Figure 11	-0.1		0.1	V	
$V_{OC(SS)}$	Steady-state common-mode output voltage	See Figure 9	2.1	2.5	2.9	V	
$\Delta V_{OC(SS)}$	Change in steady-state common-mode output voltage, $V_{OC(H)} - V_{OC(L)}$	See Figure 9 and Figure 12	-0.1		0.1	V	
$V_{OC(PP)}$	Peak-to-peak common-mode output voltage, $V_{OC(MAX)} - V_{OC(MIN)}$	$R_L = 54$ Ω , $C_L = 50$ pF, See Figure 9 and Figure 12	0.35			V	
$V_{OD(RING)}$	Differential output voltage over and under shoot	$R_L = 54$ Ω , $C_L = 50$ pF, See Figure 13			10%		
I_I	Input current	D, DE	-100		100	μ A	
I_O	Output current with power off. High impedance state output current.	$V_O = -7$ V to 12 V, Other input = 0 V	SN65HVD2[0,3]	-400		500	μ A
			SN65HVD2[1,2,4]	-100		125	
		$V_O = -20$ V to 25 V, Other input = 0 V	SN65HVD2[0,3]	-800		1000	
			SN65HVD2[1,2,4]	-200		250	
I_{OS}	Short-circuit output current	$V_O = -20$ V to 25 V, See Figure 17	-250		250	mA	
C_{OD}	Differential output capacitance				20	pF	

- (1) All typical values are at $V_{CC} = 5$ V and 25°C.

8.6 Receiver Electrical Characteristics

 over recommended operating conditions (unless otherwise noted)⁽¹⁾

PARAMETER		TEST CONDITIONS	MIN	TYP	MAX	UNIT		
$V_{IT(+)}$	Positive-going differential input voltage threshold	See Figure 18	$V_O = 2.4\text{ V}$, $I_O = -8\text{ mA}$		60	200	mV	
$V_{IT(-)}$	Negative-going differential input voltage threshold		$V_O = 0.4\text{ V}$, $I_O = 8\text{ mA}$		-200	-60		
V_{HYS}	Hysteresis voltage ($V_{IT+} - V_{IT-}$)		100	130		mV		
$V_{IT(F+)}$	Positive-going differential input failsafe voltage threshold	See Figure 23	$V_{CM} = -7\text{ V to }12\text{ V}$		40	120	200	mV
			$V_{CM} = -20\text{ V to }25\text{ V}$			120	250	
$V_{IT(F-)}$	Negative-going differential input failsafe voltage threshold	See Figure 23	$V_{CM} = -7\text{ V to }12\text{ V}$		-200	-120	-40	mV
			$V_{CM} = -20\text{ V to }25\text{ V}$		-250	-120		
V_{IK}	Input clamp voltage	$I_I = -18\text{ mA}$	-1.5			V		
V_{OH}	High-level output voltage	$V_{ID} = 200\text{ mV}$, $I_{OH} = -8\text{ mA}$, See Figure 19	4			V		
V_{OL}	Low-level output voltage	$V_{ID} = -200\text{ mV}$, $I_{OL} = 8\text{ mA}$, See Figure 19			0.4	V		
$I_{I(BUS)}$	Bus input current (power on or power off)	$V_I = -7\text{ to }12\text{ V}$, Other input = 0 V	SN65HVD2[0,3]			500	μA	
			SN65HVD2[1,2,4]	-400		125		
		$V_I = -20\text{ to }25\text{ V}$, Other input = 0 V	SN65HVD2[0,3]			1000		
			SN65HVD2[1,2,4]	-800		250		
I_I	Input current	\overline{RE}	-100		100	μA		
R_I	Input resistance	SN65HVD2[0,3]	24			k Ω		
		SN65HVD2[1,2,4]	96					
C_{ID}	Differential input capacitance	$V_{ID} = 0.5 + 0.4\text{ sine}(2\pi \times 1.5 \times 10^6\text{t})$		20		pF		

 (1) All typical values are at $V_{CC} = 5\text{ V}$ and 25°C .

8.7 Driver Switching Characteristics

 over recommended operating conditions (unless otherwise noted)⁽¹⁾

PARAMETER		TEST CONDITIONS	MIN	TYP	MAX	UNIT	
t_{PLH} , t_{PHL}	Differential output propagation delay, low-to-high and high-to-low	$R_L = 54\ \Omega$, $C_L = 50\text{ pF}$, See Figure 11	SN65HVD2[0,3]	6	10	20	ns
			SN65HVD2[1,4]	20	32	60	
			SN65HVD22	160	280	500	
t_r , t_f	Differential output rise time and fall time	$R_L = 54\ \Omega$, $C_L = 50\text{ pF}$, See Figure 11	SN65HVD2[0,3]	2	6	12	ns
			SN65HVD2[1,4]	20	40	60	
			SN65HVD22	200	400	600	
t_{PZH} , t_{PHZ}	Propagation delay time, high-impedance-to-high-level output and high-level output-to-high-impedance	\overline{RE} at 0 V, See Figure 14	SN65HVD2[0,3]			40	ns
			SN65HVD2[1,4]			100	
			SN65HVD22			300	
t_{PZL} , t_{PLZ}	Propagation delay time, high-impedance-to-high-level output and high-level output-to-high-impedance	\overline{RE} at 0 V, See Figure 15	SN65HVD2[0,3]			40	ns
			SN65HVD2[1,4]			100	
			SN65HVD22			300	
$t_{d(\text{standby})}$	Time from an active differential output to standby	\overline{RE} at V_{CC} , See Figure 16				2	μs
$t_{d(\text{wake})}$	Wake-up time from standby to an active differential output					8	μs
$t_{sk(p)}$	Pulse skew $t_{PLH} - t_{PHL}$	SN65HVD2[0,3]				2	ns
		SN65HVD2[1,4]				6	
		SN65HVD22				50	

 (1) All typical values are at $V_{CC} = 5\text{ V}$ and 25°C .

8.8 Receiver Switching Characteristics

over recommended operating conditions (unless otherwise noted)

PARAMETER		TEST CONDITIONS		MIN	TYP	MAX	UNIT
t_{PLH}	Propagation delay time, low-to-high level output and high-to low level output	See Figure 19	SN65HVD2[0,3]		16	35	ns
t_{PHL}			SN65HVD2[1,2,4]		25	50	
t_r t_f	Receiver output rise time Receiver output fall time	See Figure 19			2	4	ns
t_{PZH} t_{PHZ}	Receiver output enable time to high level and disable time from high level	See Figure 20			90	120	ns
					16	35	
t_{PZL} t_{PLZ}	Receiver output enable time to low level and disable time from low level	See Figure 21			90	120	ns
					16	35	
$t_{r(standby)}$	Time from an active receiver output to standby	See Figure 22, DE at 0 V				2	μ s
$t_{r(wake)}$	Wake-up time from standby to an active receiver output	See Figure 22, DE at 0 V				8	μ s
$t_{sk(p)}$	Pulse skew $ t_{PLH} - t_{PHL} $					5	ns
$t_{p(set)}$	Delay time, bus fail to failsafe set	See Figure 23, pulse rate = 1 kHz			250	350	μ s
$t_{p(reset)}$	Delay time, bus recovery to failsafe reset	See Figure 23, pulse rate = 1 kHz			50		ns

8.9 Receiver Equalization Characteristics⁽¹⁾

 over recommended operating conditions (unless otherwise noted)⁽²⁾

PARAMETER		TEST CONDITIONS			TYP	UNIT	
$t_{j(pp)}$	Peak-to-peak eye-pattern jitter	Pseudo-random NRZ code with a bit pattern length of $2^{16} - 1$, Belden 3105A cable, See Figure 26	25 Mbps	0 m	SN65HVD23	2	ns
				100 m	SN65HVD20	6	
					SN65HVD23	3	
				150 m	SN65HVD20	15	ns
					SN65HVD23	4	
				200 m	SN65HVD20	27	ns
			SN65HVD23		8		
			10 Mbps	200 m	SN65HVD20	22	ns
					SN65HVD23	8	
				250 m	SN65HVD20	34	ns
					SN65HVD23	15	
				300 m	SN65HVD20	49	ns
					SN65HVD23	27	
			5 Mbps	500 m	SN65HVD21	128	ns
					SN65HVD24	18	
			3 Mbps	500 m	SN65HVD20	93	ns
SN65HVD21	103						
SN65HVD23	90						
SN65HVD24	16						
1 Mbps	1000 m	SN65HVD21	216	ns			
		SN65HVD24	62				

(1) The SN65HVD20 and SN65HVD21 do not have receiver equalization, but are specified for comparison.

 (2) All typical values are at $V_{CC} = 5$ V, and temperature = 25°C.

8.10 Power Dissipation

PARAMETERS		TEST CONDITIONS		VALUE	UNIT	
P _D	Device power dissipation	Typical	V _{CC} = 5 V, T _J = 25°C, R _L = 54 Ω, C _L = 50 pF (driver), C _L = 15 pF (receiver), 50% Duty cycle square-wave signal, Driver and receiver enabled	SN65HVD20: 25 Mbps	295	mW
				SN65HVD21: 5 Mbps	260	
				SN65HVD22: 500 kbps	233	
				SN65HVD23: 25 Mbps	302	
				SN65HVD24: 5 Mbps	267	
		Worst case	V _{CC} = 5.5 V, T _J = 125°C, R _L = 54 Ω, C _L = 50 pF, C _L = 15 pF (receiver), 50% Duty cycle square-wave signal, Driver and receiver enabled	SN65HVD20: 25 Mbps	408	mW
				SN65HVD21: 5 Mbps	342	
				SN65HVD22: 500 kbps	300	
				SN65HVD23: 25 Mbps	417	
				SN65HVD24: 5 Mbps	352	
T _{SD}	Thermal shut down junction temperature			170	°C	

8.11 Typical Characteristics

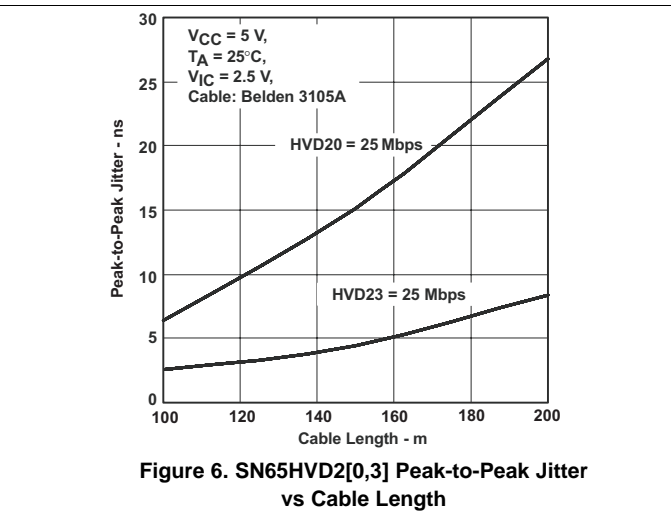
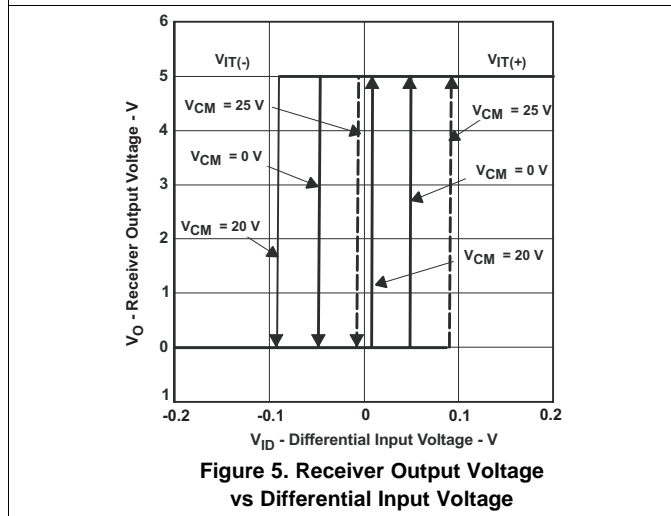
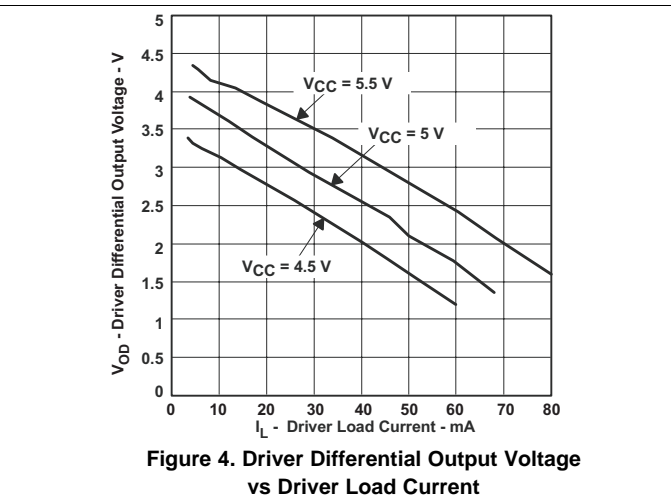
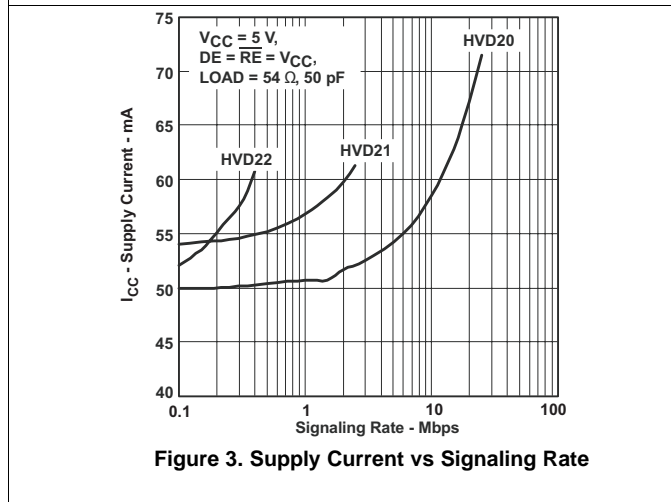
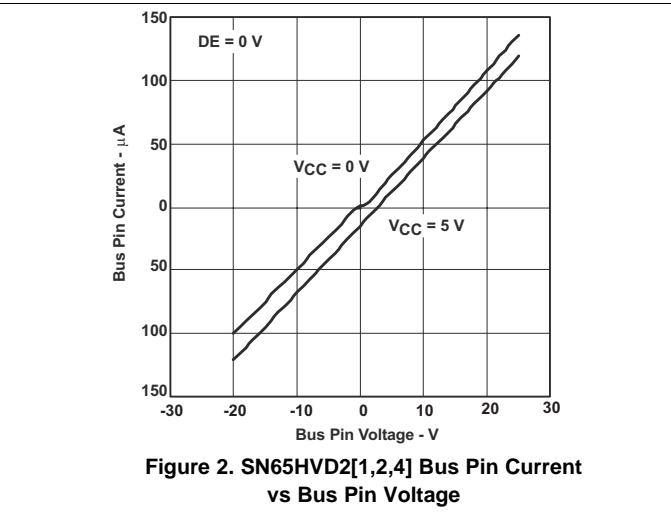
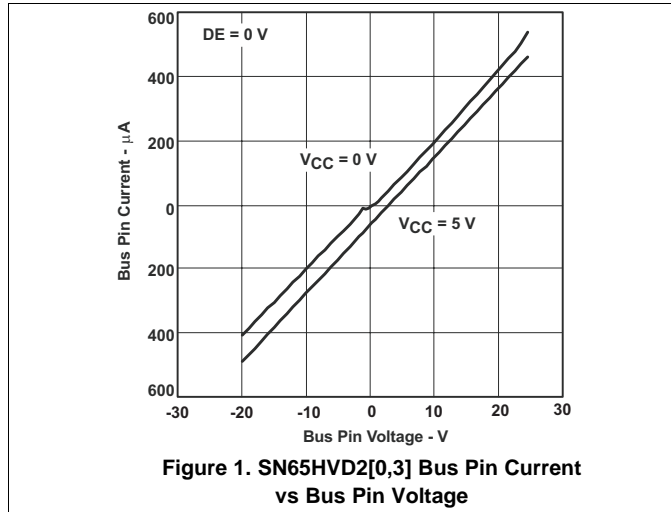

Typical Characteristics (continued)

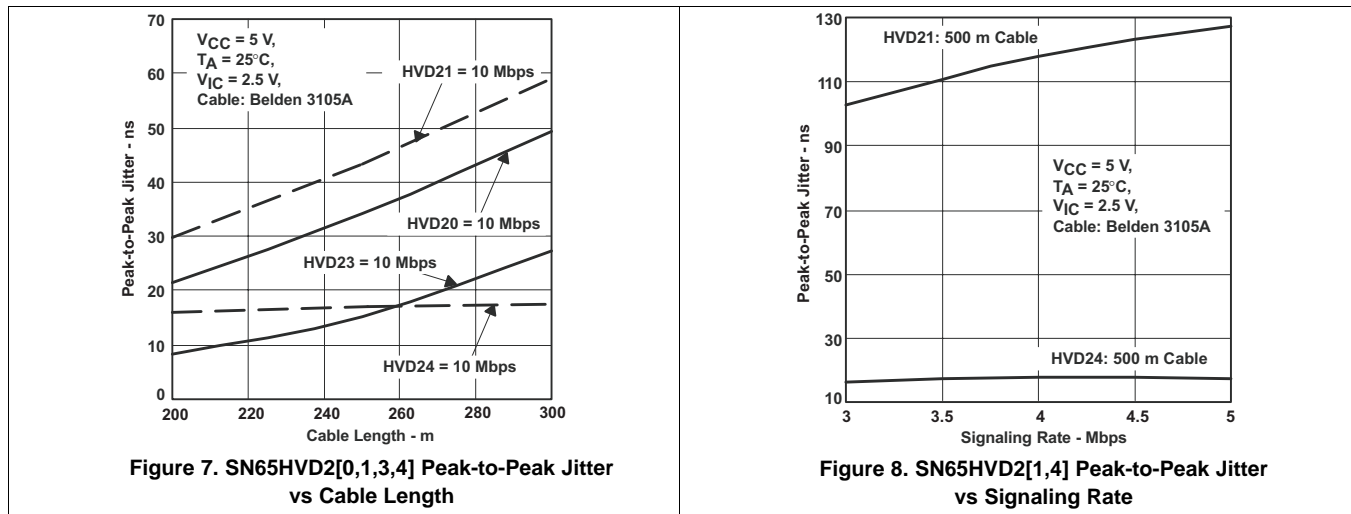

9 Parameter Measurement Information

NOTE

Test load capacitance includes probe and jig capacitance (unless otherwise specified). Signal generator characteristics: rise and fall time < 6 ns, pulse rate 100 kHz, 50% duty cycle, $Z_o = 50\ \Omega$ (unless otherwise specified).

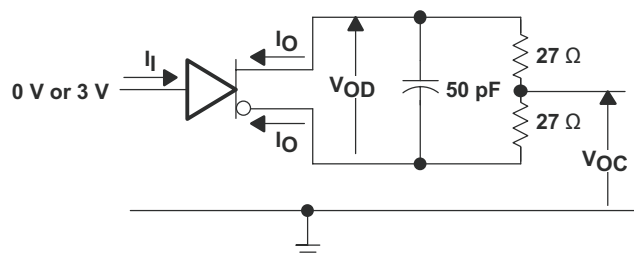

Figure 9. Driver Test Circuit, V_{OD} and V_{OC} Without Common-Mode Loading

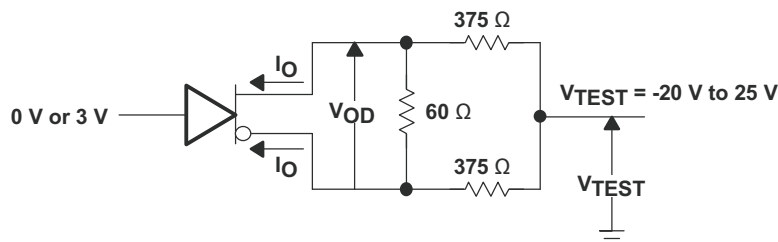

Figure 10. Driver Test Circuit, V_{OD} With Common-Mode Loading

Parameter Measurement Information (continued)

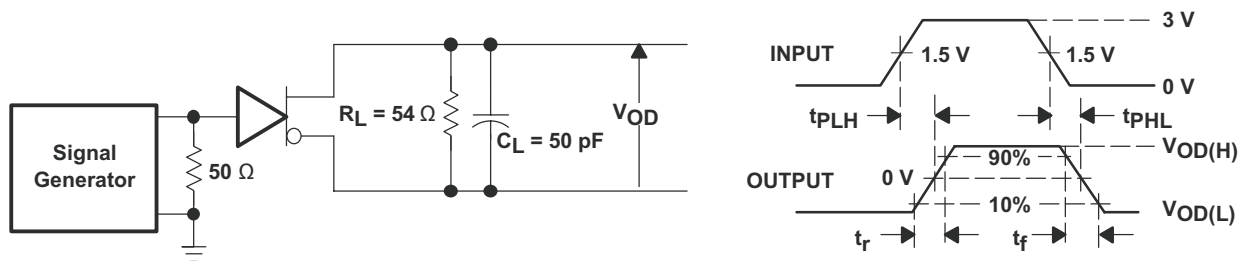

Figure 11. Driver Switching Test Circuit and Waveforms

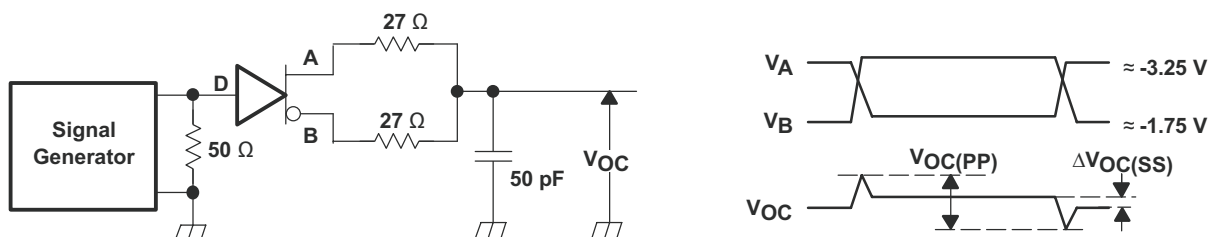
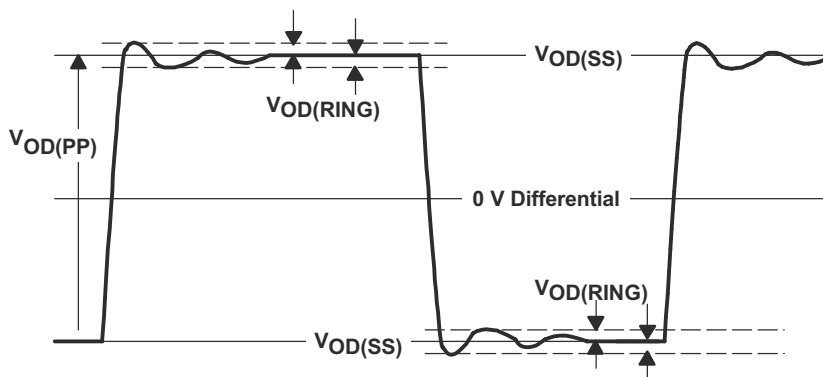

Figure 12. Driver V_{OC} Test Circuit and Waveforms



$V_{OD(RING)}$ is measured at four points on the output waveform, corresponding to overshoot and undershoot from the $V_{OD(H)}$ and $V_{OD(L)}$ steady state values.

Figure 13. $V_{OD(RING)}$ Waveform and Definitions

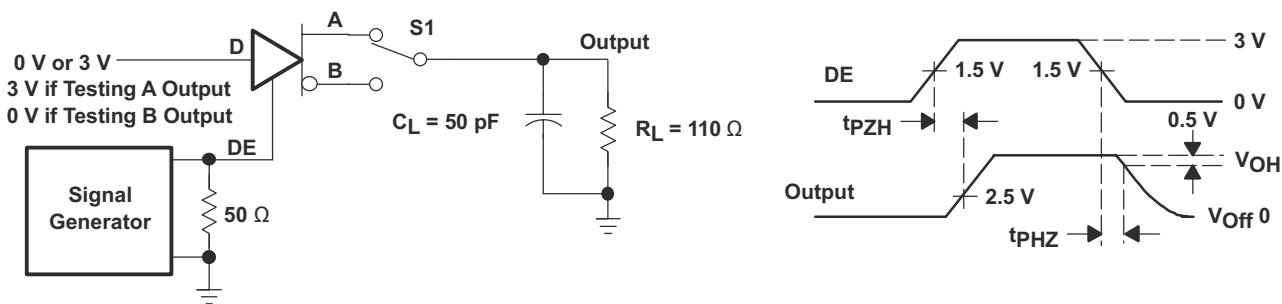

Figure 14. Driver Enable and Disable Test, High Output

Parameter Measurement Information (continued)

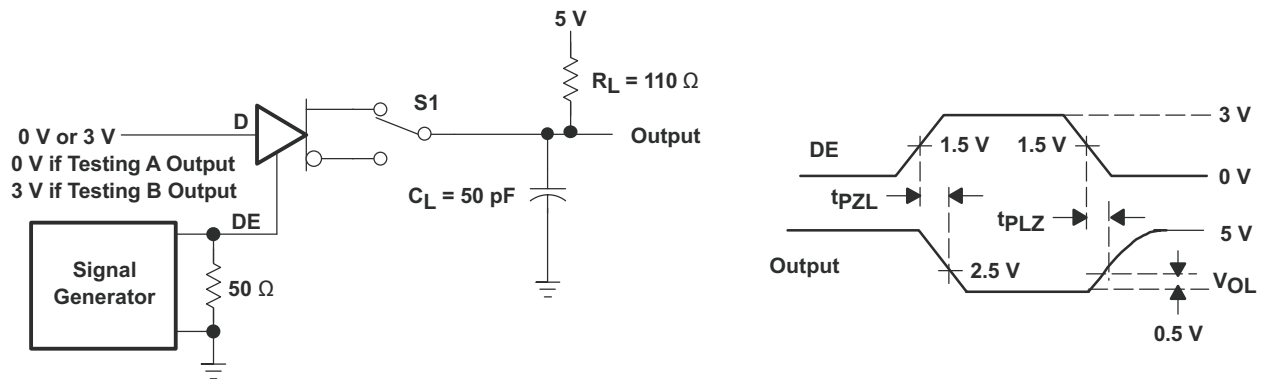

Figure 15. Driver Enable and Disable Test, Low Output

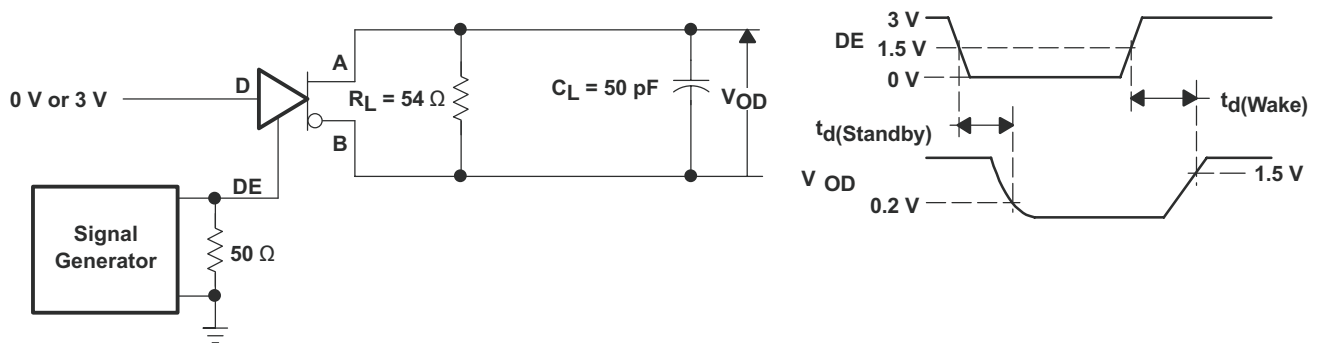

Figure 16. Driver Standby and Wake Test Circuit and Waveforms

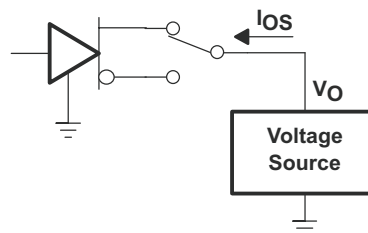

Figure 17. Driver Short-Circuit Test

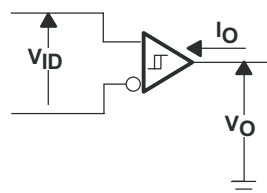

Figure 18. Receiver DC Parameter Definitions

Parameter Measurement Information (continued)

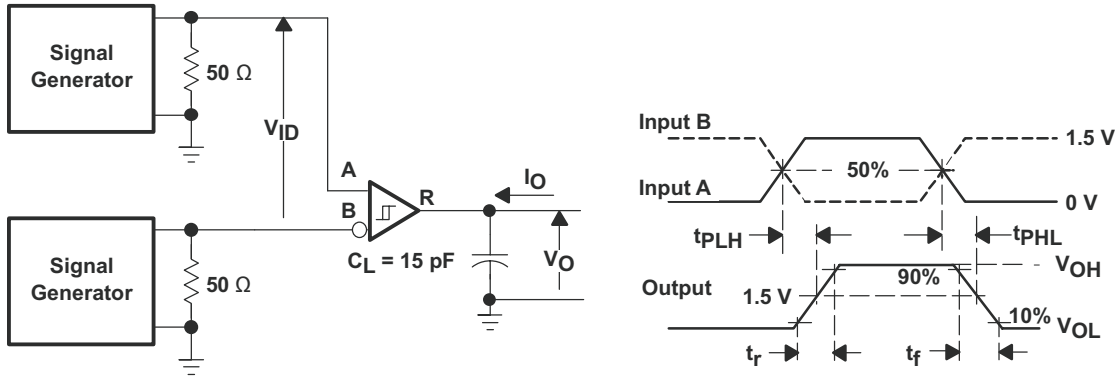

Figure 19. Receiver Switching Test Circuit and Waveforms

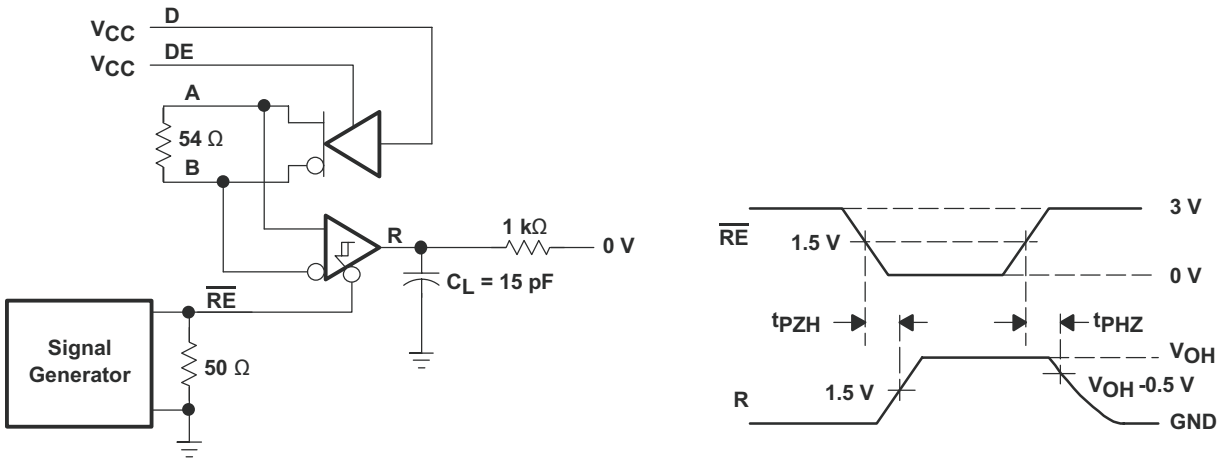

Figure 20. Receiver Enable Test Circuit and Waveforms, Data Output High

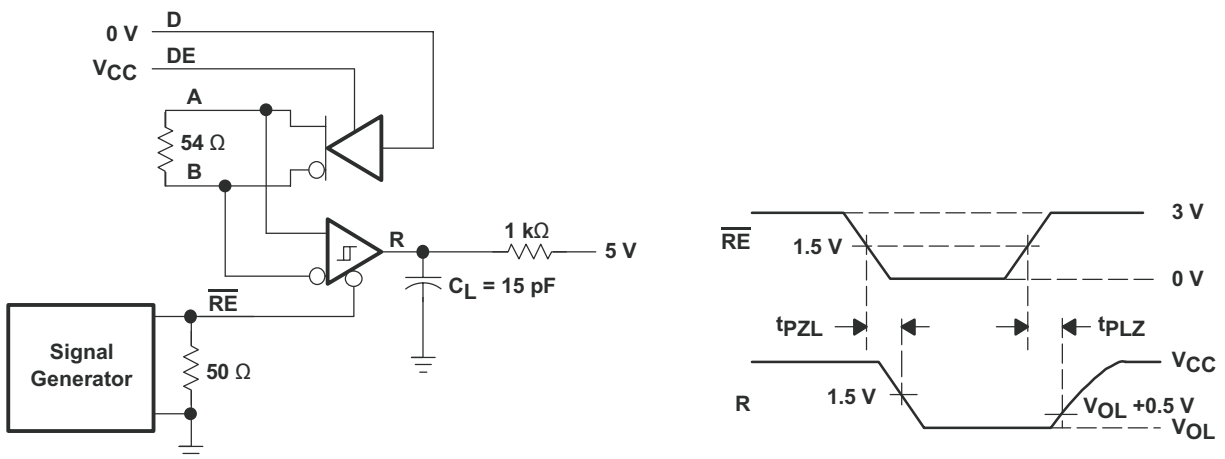

Figure 21. Receiver Enable Test Circuit and Waveforms, Data Output Low

Parameter Measurement Information (continued)

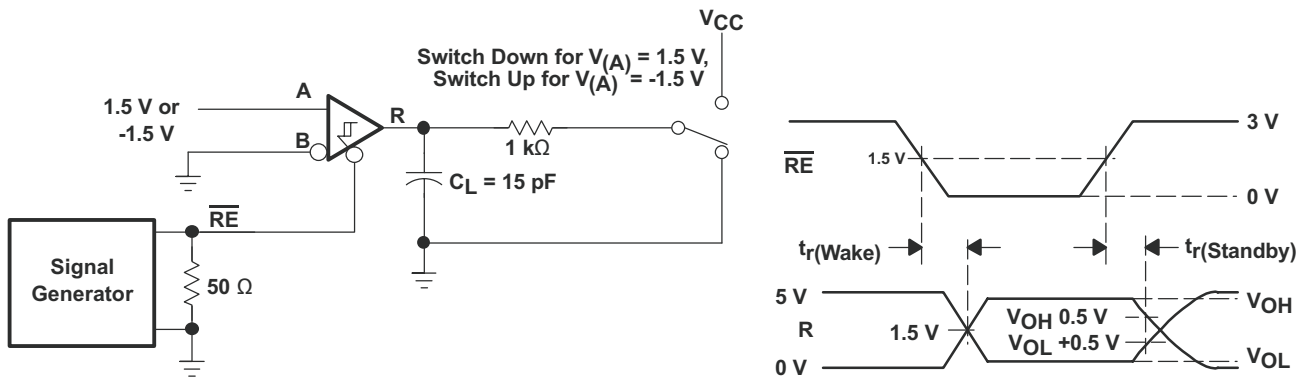

Figure 22. Receiver Standby and Wake Test Circuit and Waveforms

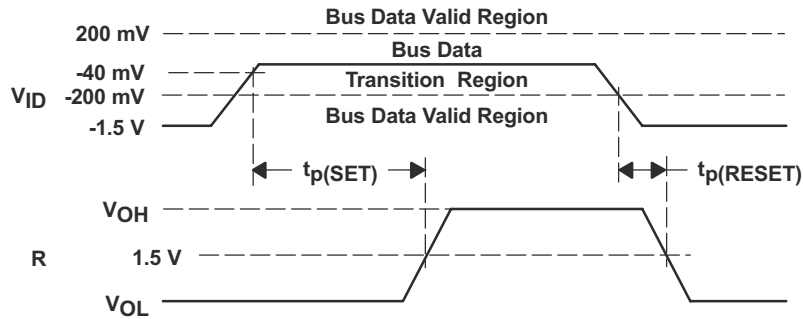

Figure 23. Receiver Active Failsafe Definitions and Waveforms

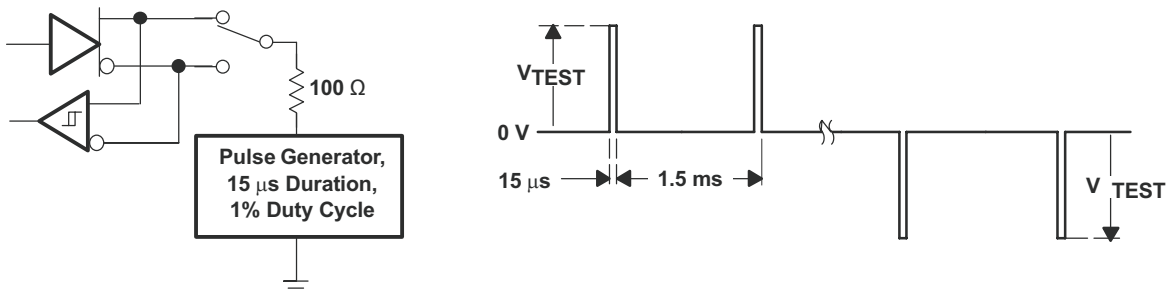

Figure 24. Test Circuit and Waveforms, Transient Overvoltage Test

10 Detailed Description

10.1 Overview

The SN65HVD2x family of devices are RS-485 compliant half-duplex transceivers designed for communication rates up to 500 kbps (SN65HVD22), 3 Mbps (SN65HVD24), 5 Mbps (SN65HVD21), or 25 Mbps (SN65HVD20 and SN65HVD23). The devices feature extended common-mode range support, which provides immunity to larger ground potential differences that can occur between nodes that communicate over longer distances. The SN65HVD23 and the SN65HVD24 devices feature receiver equalization, which reduces the amount of data-dependent jitter that is introduced by the high-frequency losses associated with long cables.

10.2 Functional Block Diagram

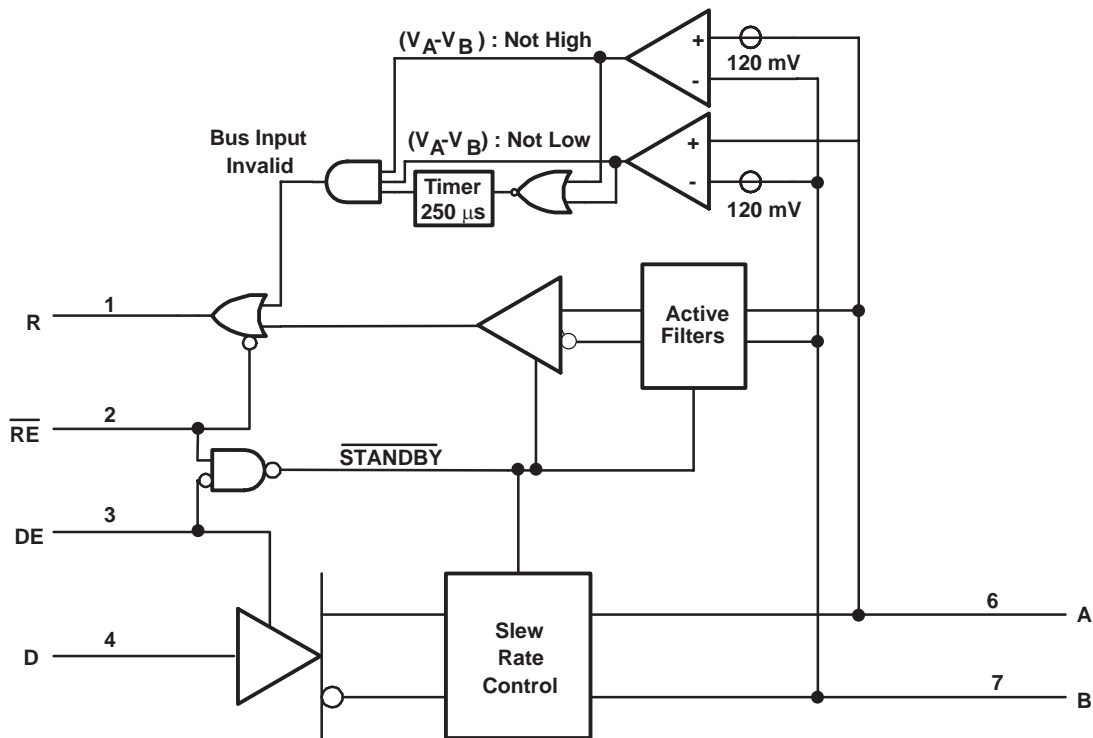

Copyright © 2016, Texas Instruments Incorporated

10.3 Feature Description

The SN65HVD2x family of devices integrates a differential receiver and differential driver with additional features for improved performance in electrically-noisy, long-cable, or other fault-intolerant applications.

The receiver hysteresis (typically 130 mV) is much larger than found in typical RS-485 transceivers. This helps reject spurious noise signals which would otherwise cause false changes in the receiver output state.

Slew rate limiting on the driver outputs (SN65HVD2[1,2,4]) reduces the high-frequency content of signal edges. This decreases reflections from bus discontinuities, and allows longer stub lengths between nodes and the main bus line. Designers must consider the maximum signaling rate and cable length required for a specific application, and choose the transceiver best matching those requirements.

When DE is low, the differential driver is disabled, and the A and B outputs are in high-impedance states. When DE is high, the differential driver is enabled, and drives the A and B outputs according to the state of the D inputs.

When \overline{RE} is high, the differential receiver output buffer is disabled, and the R output is in a high-impedance state. When \overline{RE} is low, the differential receiver is enabled, and the R output reflects the state of the differential bus inputs on the A and B pins.

Feature Description (continued)

If both the driver and receiver are disabled, (DE low and \overline{RE} high) then all nonessential circuitry, including auxiliary functions such as failsafe and receiver equalization is placed in a low-power standby state. This reduces power consumption to less than 5 μ W. When either enable input is asserted, the circuitry again becomes active.

In addition to the primary differential receiver, these devices incorporate a set of comparators and logic to implement an active receiver failsafe feature. These components determine whether the differential bus signal is valid. Whenever the differential signal is close to zero volts (neither high nor low), a timer initiates. If the differential input remains within the transition range for more than 250 μ s, the timer expires and set the receiver output to the high state. If a valid bus input (high or low) is received at any time, the receiver output reflects the valid bus state, and the timer is reset.

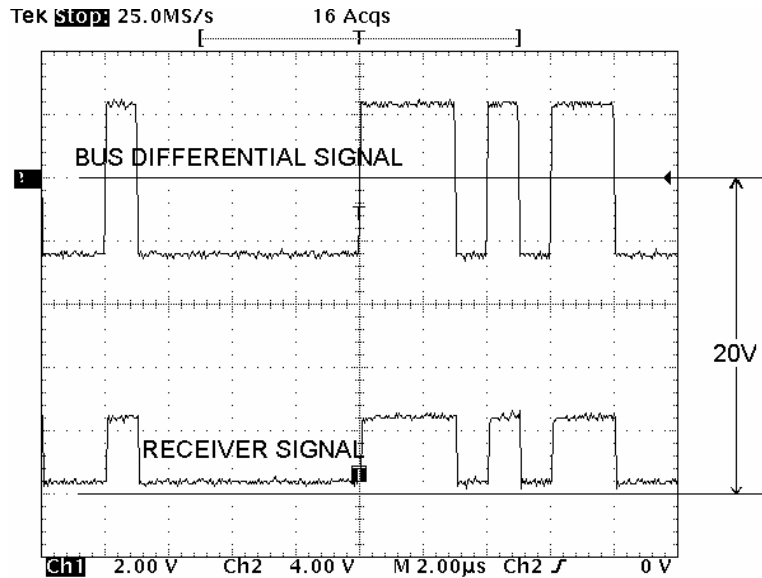

Figure 25. SN65HVD22 Receiver Operation With 20-V Offset on Input Signal

$H(s) = k_0 \left[(1-k_1) + \frac{k_1 p_1}{(s + p_1)} \right] \left[(1-k_2) + \frac{k_2 p_2}{(s + p_2)} \right] \left[(1-k_3) + \frac{k_3 p_3}{(s + p_3)} \right]$	k0 (DC loss)	p1 (MHz)	k1	p2 (MHz)	k2	p3 (MHz)	k3
Similar to 160m of Belden 3105A	0.95	0.25	0.3	3.5	0.5	15	1
Similar to 250m of Belden 3105A	0.9	0.25	0.4	3.5	0.7	12	1
Similar to 500m of Belden 3105A	0.8	0.25	0.6	2.2	1	8	1
Similar to 1000m of Belden 3105A	0.6	0.3	1	3	1	6	1

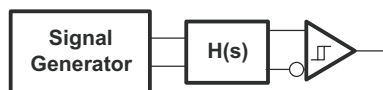

Figure 26. Cable Attenuation Model for Jitter Measurements

10.4 Device Functional Modes

The driver and receiver behavior for different input conditions are shown in [Table 3](#) and [Table 4](#), respectively.

Table 3. Driver Function Table⁽¹⁾

DEVICE	INPUT	ENABLE	OUTPUTS	
	D	DE	A	B
SN65HVD2[0,1,2]	H	H	H	L
	L	H	L	H
	X	L	Z	Z
	X	OPEN	Z	Z
	OPEN	H	H	L
SN65HVD2[3,4]	H	H	H	L
	L	H	L	H
	X	L	Z	Z
	X	OPEN	Z	Z
	OPEN	H	L	H

(1) Legend: H = high level, L = low level, X = don't care, Z = high impedance (off), ? = indeterminate

Table 4. Receiver Function Table⁽¹⁾

DIFFERENTIAL INPUT $V_{ID} = (V_A - V_B)$	ENABLE \overline{RE}	OUTPUT R
$0.2\text{ V} \leq V_{ID}$	L	H
$-0.2\text{ V} < V_{ID} < 0.2\text{ V}$	L	H ⁽²⁾
$V_{ID} \leq -0.2\text{ V}$	L	L
X	H	Z
X	OPEN	Z
Open circuit	L	H
Short Circuit	L	H
Idle (terminated) bus	L	H

(1) H = high level, L = low level, Z = high impedance (off)

(2) If the differential input V_{ID} remains within the transition range for more than 250 μs , the integrated failsafe circuitry detects a bus fault, and set the receiver output to a high state. See [Figure 23](#).

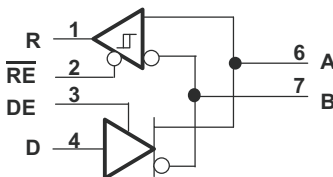

Figure 27. Logic Diagram

10.4.1 Test Mode Driver Disable

If the input signal to the D pin is such that:

1. the signal has signaling rate above 4 Mbps (for the SN65HVD21 and SN65HVD24),
2. the signal has signaling rate above 6 Mbps (for the SN65HVD20 and SN65HVD23),
3. the signal has average amplitude from 1.2 V to 1.6 V ($1.4\text{ V} \pm 200\text{ mV}$), or
4. the average signal amplitude remains in this range for 100 μs or longer,

then the driver may activate a test-mode during which the driver outputs are temporarily disabled. This can cause loss of transmission of data during the period that the device is in the test-mode. The driver is re-enabled and resumes normal operation whenever the above conditions are not true. The device is not damaged by this test mode.

Although rare, there are combinations of specific voltage levels and input data patterns within the operating conditions of the SN65HVD2x family which may lead to a temporary state where the driver outputs are disabled for a period of time.

Observations:

1. The conditions for inadvertently entering the test mode are dependent on the levels, duration, and duty cycle of the logic signal input to the D pin. Operating input levels are specified as greater than 2 V for a logic HIGH input, and less than 0.8 V for a logic LOW input. Therefore, a valid steady-state logic input does not cause the device to activate the test mode
2. Only input signals with frequency content above 2 MHz (4 Mbps) have a possibility of activating the test mode. Therefore, this issue should not affect the normal operation of the SN65HVD22 (500 kbps).
3. For operating signaling rates of 4 Mbps (or above), the conditions stated above must remain true over a period of: $4\text{ Mbps} \times 100\ \mu\text{s} = 400\text{ bits}$. Therefore, a normal short message does not inadvertently activate the test model.
4. One example of an input signal which may cause the test mode to activate is a clock signal with frequency 3 MHz and 50% duty cycle (symmetric HIGH and LOW half-cycles) with logic HIGH levels of 2.4 V and logic LOW levels of 0.4 V. This signal applied to the D pin as a driver input would meet the criteria listed above, and may cause the test-mode to activate, which would disable the driver. This example situation may occur if the clock signal is generated from a microcontroller or logic chip with a 2.7-V supply.

10.4.2 Equivalent Input and Output Schematic Diagrams

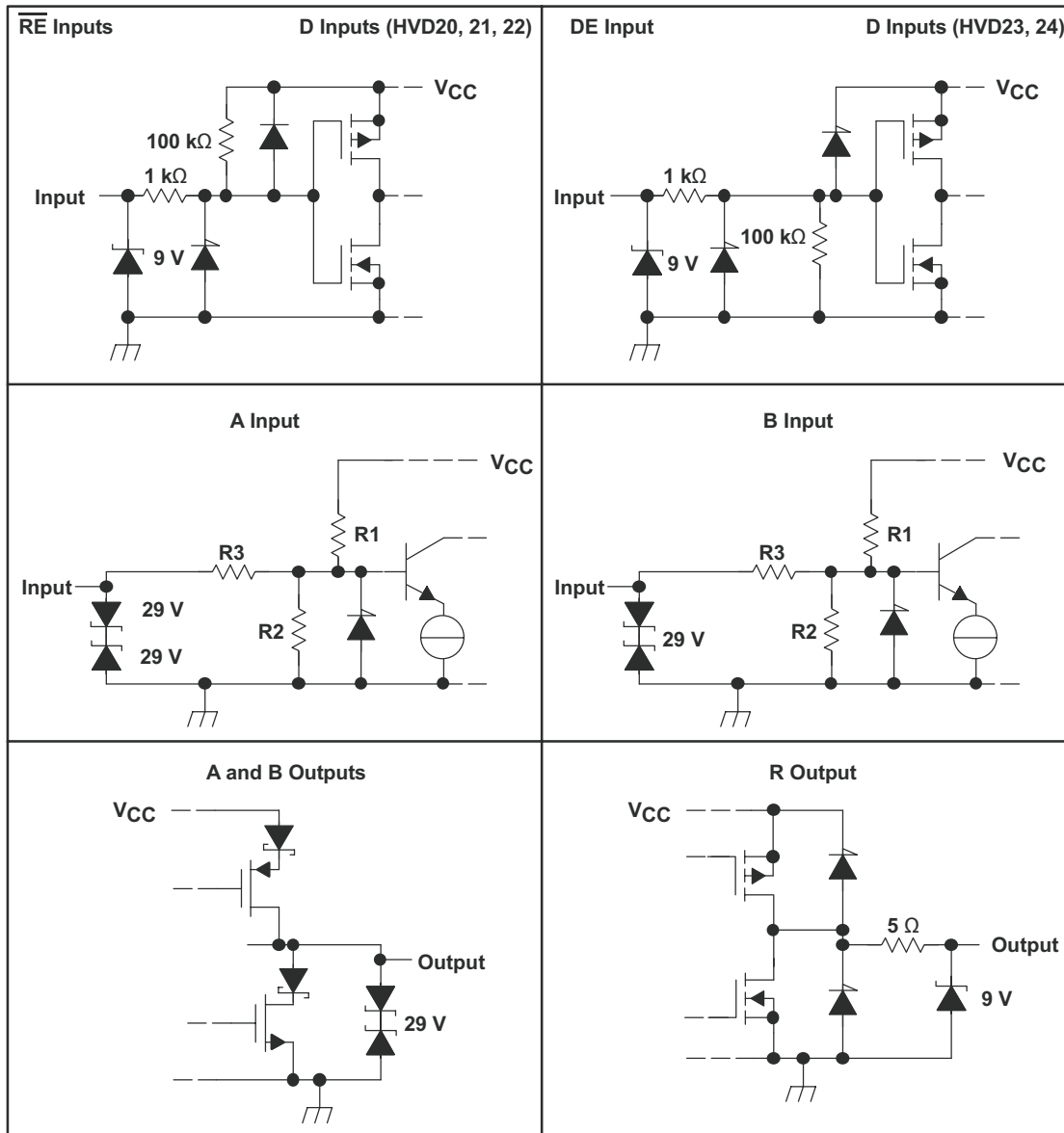

Figure 28. Equivalent Input and Output Schematic Diagrams

Table 5. Input and Output Resistor Values

DEVICE	R1, R2	R3
SN65HVD2[0,3]	9 kΩ	45 kΩ
SN65HVD2[1,2,4]	36 kΩ	180 kΩ

11 Application and Implementation

NOTE

Information in the following applications sections is not part of the TI component specification, and TI does not warrant its accuracy or completeness. TI's customers are responsible for determining suitability of components for their purposes. Customers should validate and test their design implementation to confirm system functionality.

11.1 Application Information

The SN65HVD2x devices are half-duplex RS-485 transceivers that can be used for bidirectional, multipoint communication at various data rates over differential transmission lines. These devices support a wide common-mode range, allowing for robust communication even in the presence of voltage differences between the reference potentials of different nodes on a network.

11.2 Typical Application

Figure 29 shows a typical RS-485 application. Transceivers of different nodes are connected to one another over a shared bus. Twisted-pair cabling with a controlled differential impedance is used, and termination resistances are placed at the two ends of the cable to match the transmission line impedance and minimize signal reflections.

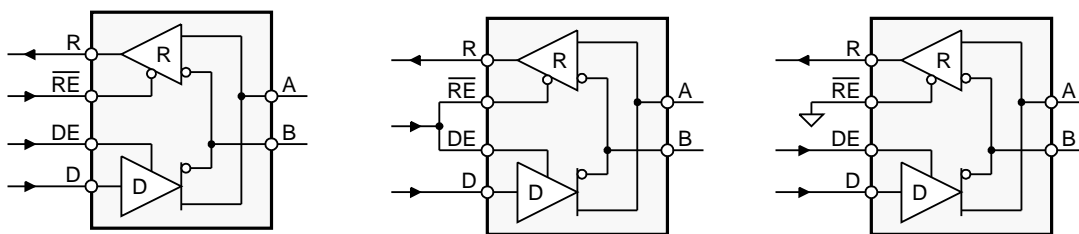

Copyright © 2016, Texas Instruments Incorporated

Figure 29. Half-Duplex Transceiver Configurations

11.2.1 Design Requirements

As the distances between nodes in an RS-485 network become greater and greater, it becomes more of a challenge to ensure reliable communication. The increased distance often means that the reference (ground) potentials has more of a difference between nodes. These ground potential differences give rise to differences in the common-mode voltages seen by the various transceivers on the bus. Standard RS-485 transceivers are typically specified to operate over a common-mode voltage from -7 V to 12 V , which may be insufficient for larger distances. The SN65HVD2x family of devices extends this range to -20 V to 25 V , allowing for greater communication distances between nodes.

Increased cable lengths can lead to increased jitter, especially in links operating at high data rates. This increased jitter is due to the attenuation of the cable, which tends to increase with frequency. Having unequal loss between higher and lower frequencies causes the RS-485 signal to distort, adding some timing deviation (jitter) to the edge crossings of the RS-485 data. If the jitter amplitude exceeds the jitter tolerance of the receiving MCU or UART, then bit errors are likely to result in the link. However, jitter can be reduced for a given link through the use of receiver equalization.

11.2.2 Detailed Design Procedure

11.2.2.1 Noise Considerations for Equalized Receivers

The simplest way of overcoming the effects of cable losses is to increase the sensitivity of the receiver. If the maximum attenuation of frequencies of interest is 20 dB , increasing the receiver gain by a factor of ten compensates for the cable. However, this means that signal and noise are amplified. Therefore, the receiver with higher gain is more sensitive to noise and it is important to minimize differential noise coupling to the equalized receiver.

Typical Application (continued)

Differential noise is created when conducted or radiated noise energy generates more voltage on one line of the differential pair than the other. For this to occur from conducted or electric far-field noise, the impedance to ground of the lines must differ.

For noise frequency out to 50 MHz, the input traces can be treated as a lumped capacitance if the receiver is approximately 10 inches or less from the connector. Therefore, matching impedance of the lines is accomplished by matching the lumped capacitance of each.

The primary factors that affect the capacitance of a trace are in length, thickness, width, dielectric material, distance from the signal return path, stray capacitance, and proximity to other conductors. It is difficult to match each of the variables for each line of the differential pair exactly, but a reasonable effort to do so keeps the lines balanced and less susceptible to differential noise coupling.

Another source of differential noise is from near-field coupling. In this situation, an assumption of equal noise-source impedance cannot be made as in the far-field. Familiarly known as crosstalk, more energy from a nearby signal is coupled to one line of the differential pair. Minimization of this differential noise is accomplished by keeping the signal pair close together and physical separation from high-voltage, high-current, or high-frequency signals.

In summary, follow these guidelines in board layout for keeping differential noise to a minimum.

- Keep the differential input traces short.
- Match the length, physical dimensions, and routing of each line of the pair.
- Keep the lines close together.
- Match components connected to each line.
- Separate the inputs from high-voltage, high-frequency, or high-current signals.

11.2.3 Application Curves

Figure 30 illustrates the benefits of integrated receiver equalization as implemented in the SN65HVD23 transceiver. In this test setup, a differential signal generator applied a signal voltage at one end of the cable, which was Belden 3105A twisted-pair shielded cable. The test signal was a pseudo-random bit stream (PRBS) of nonreturn-to-zero (NRZ) data. Channel 1 (top) shows the eye-pattern of the differential voltage at the receiver inputs (after the cable attenuation). Channel 2 (bottom) shows the output of the receiver.

Figure 31 illustrates the benefits of integrated receiver equalization as implemented in the SN65HVD24 transceiver. In this test setup, a differential signal generator applied a signal voltage at one end of the cable, which was Belden 3105A twisted-pair shielded cable. The test signal was a pseudo-random bit stream (PRBS) of nonreturn-to-zero (NRZ) data. Channel 1 (top) shows the eye-pattern of the bit stream. Channel 2 (middle) shows the eye-pattern of the differential voltage at the receiver inputs (after the cable attenuation). Channel 3 (bottom) shows the output of the receiver.

Typical Application (continued)

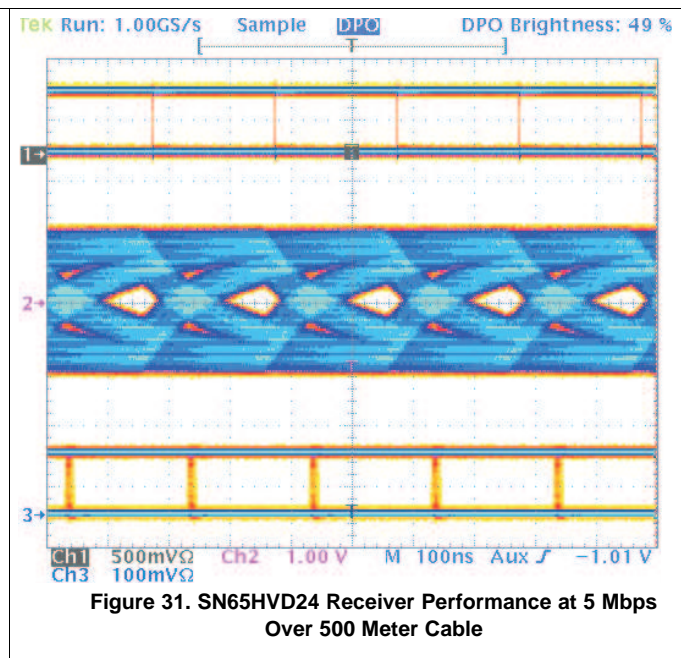
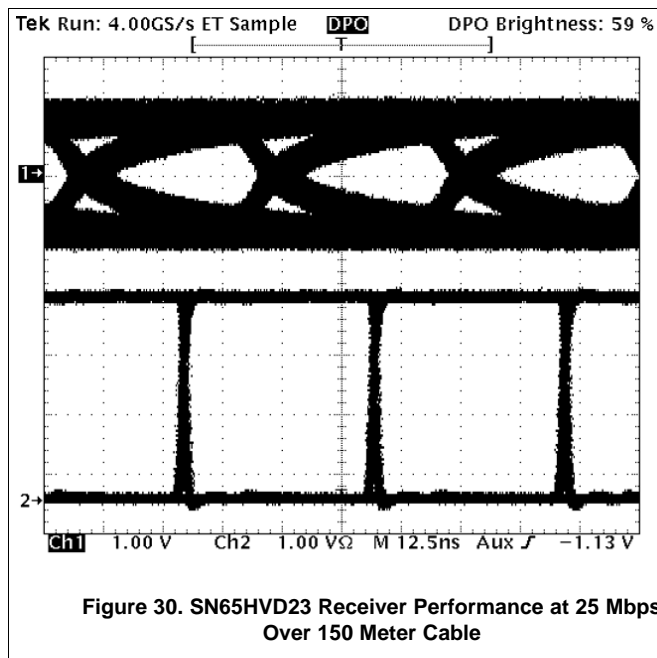

12 Power Supply Recommendations

To ensure reliable operation at all data rates and supply voltages, each supply must be decoupled with a 100-nF ceramic capacitor placed as close to the supply pins as possible. This helps to reduce supply voltage ripple present on the outputs of switched-mode power supplies and also helps to compensate for the resistance and inductance of the PCB power planes.

13 Layout

13.1 Layout Guidelines

In addition to the guidelines on differential trace matching given in [Detailed Design Procedure](#), the layout guidelines below must be followed:

- Route power and ground nets as planes rather than traces, and keep their widths as large as possible to minimize resistance and inductance while maximizing parasitic capacitance.
- If external components (like transient voltage suppression diodes) are used for transient protection, place them close to the connector port and within the path of the signal lines. Make sure component capacitances are small enough not to impact the RS-485 signaling at the chosen data rate.
- Small-valued series pulse-proof resistances can be used to provide additional immunity to transients. This is needed to limit input currents if the clamping voltages of external transient protection devices exceed the absolute maximum ratings of the transceiver. These resistances must be less than 10 Ω so that the RS-485 signal is not overly attenuated.

13.2 Layout Example

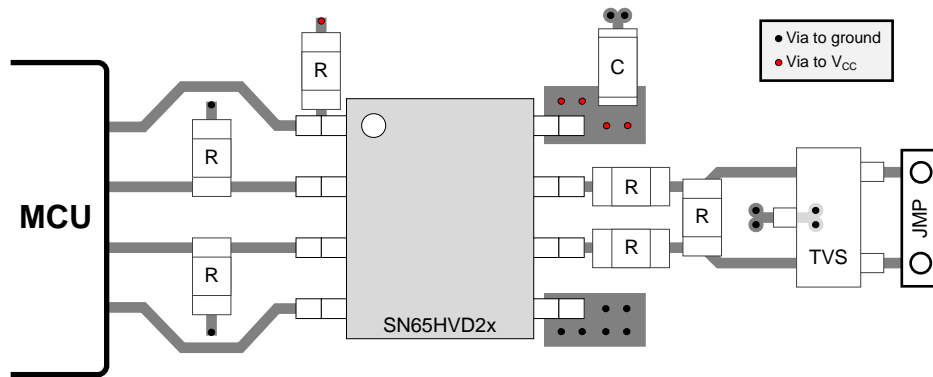

Figure 32. SN65HVD2x Layout Example

14 Device and Documentation Support

14.1 Related Links

The table below lists quick access links. Categories include technical documents, support and community resources, tools and software, and quick access to sample or buy.

Table 6. Related Links

PARTS	PRODUCT FOLDER	SAMPLE & BUY	TECHNICAL DOCUMENTS	TOOLS & SOFTWARE	SUPPORT & COMMUNITY
SN65HVD20	Click here	Click here	Click here	Click here	Click here
SN65HVD21	Click here	Click here	Click here	Click here	Click here
SN65HVD22	Click here	Click here	Click here	Click here	Click here
SN65HVD23	Click here	Click here	Click here	Click here	Click here
SN65HVD24	Click here	Click here	Click here	Click here	Click here

14.2 Receiving Notification of Documentation Updates

To receive notification of documentation updates, navigate to the device product folder on ti.com. In the upper right corner, click on *Alert me* to register and receive a weekly digest of any product information that has changed. For change details, review the revision history included in any revised document.

14.3 Community Resources

The following links connect to TI community resources. Linked contents are provided "AS IS" by the respective contributors. They do not constitute TI specifications and do not necessarily reflect TI's views; see TI's [Terms of Use](#).

TI E2E™ Online Community *TI's Engineer-to-Engineer (E2E) Community*. Created to foster collaboration among engineers. At e2e.ti.com, you can ask questions, share knowledge, explore ideas and help solve problems with fellow engineers.

Design Support *TI's Design Support* Quickly find helpful E2E forums along with design support tools and contact information for technical support.

14.4 Trademarks

E2E is a trademark of Texas Instruments.
All other trademarks are the property of their respective owners.

14.5 Electrostatic Discharge Caution



These devices have limited built-in ESD protection. The leads should be shorted together or the device placed in conductive foam during storage or handling to prevent electrostatic damage to the MOS gates.

14.6 Glossary

[SLYZ022](#) — *TI Glossary*.

This glossary lists and explains terms, acronyms, and definitions.

15 Mechanical, Packaging, and Orderable Information

The following pages include mechanical, packaging, and orderable information. This information is the most current data available for the designated devices. This data is subject to change without notice and revision of this document. For browser-based versions of this data sheet, refer to the left-hand navigation.

PACKAGING INFORMATION

Orderable Device	Status (1)	Package Type	Package Drawing	Pins	Package Qty	Eco Plan (2)	Lead/Ball Finish (6)	MSL Peak Temp (3)	Op Temp (°C)	Device Marking (4/5)	Samples
SN65HVD20D	ACTIVE	SOIC	D	8	75	Green (RoHS & no Sb/Br)	CU NIPDAU	Level-1-260C-UNLIM	-40 to 85	VP20	Samples
SN65HVD20DG4	ACTIVE	SOIC	D	8	75	Green (RoHS & no Sb/Br)	CU NIPDAU	Level-1-260C-UNLIM	-40 to 85	VP20	Samples
SN65HVD20DR	ACTIVE	SOIC	D	8	2500	Green (RoHS & no Sb/Br)	CU NIPDAU	Level-1-260C-UNLIM	-40 to 85	VP20	Samples
SN65HVD20P	ACTIVE	PDIP	P	8	50	Pb-Free (RoHS)	CU NIPDAU	N / A for Pkg Type	-40 to 85	65HVD20	Samples
SN65HVD21D	ACTIVE	SOIC	D	8	75	Green (RoHS & no Sb/Br)	CU NIPDAU	Level-1-260C-UNLIM	-40 to 85	VP21	Samples
SN65HVD21DG4	ACTIVE	SOIC	D	8	75	Green (RoHS & no Sb/Br)	CU NIPDAU	Level-1-260C-UNLIM	-40 to 85	VP21	Samples
SN65HVD21DR	ACTIVE	SOIC	D	8	2500	Green (RoHS & no Sb/Br)	CU NIPDAU	Level-1-260C-UNLIM	-40 to 85	VP21	Samples
SN65HVD21DRG4	ACTIVE	SOIC	D	8	2500	Green (RoHS & no Sb/Br)	CU NIPDAU	Level-1-260C-UNLIM	-40 to 85	VP21	Samples
SN65HVD21P	ACTIVE	PDIP	P	8	50	Pb-Free (RoHS)	CU NIPDAU	N / A for Pkg Type	-40 to 85	65HVD21	Samples
SN65HVD21PE4	ACTIVE	PDIP	P	8	50	Pb-Free (RoHS)	CU NIPDAU	N / A for Pkg Type	-40 to 85	65HVD21	Samples
SN65HVD22D	ACTIVE	SOIC	D	8	75	Green (RoHS & no Sb/Br)	CU NIPDAU	Level-1-260C-UNLIM	-40 to 85	VP22	Samples
SN65HVD22DG4	ACTIVE	SOIC	D	8	75	Green (RoHS & no Sb/Br)	CU NIPDAU	Level-1-260C-UNLIM	-40 to 85	VP22	Samples
SN65HVD22DR	ACTIVE	SOIC	D	8	2500	Green (RoHS & no Sb/Br)	CU NIPDAU	Level-1-260C-UNLIM	-40 to 85	VP22	Samples
SN65HVD22DRG4	ACTIVE	SOIC	D	8	2500	Green (RoHS & no Sb/Br)	CU NIPDAU	Level-1-260C-UNLIM	-40 to 85	VP22	Samples
SN65HVD22P	ACTIVE	PDIP	P	8	50	Pb-Free (RoHS)	CU NIPDAU	N / A for Pkg Type	-40 to 85	65HVD22	Samples
SN65HVD22PE4	ACTIVE	PDIP	P	8	50	Pb-Free (RoHS)	CU NIPDAU	N / A for Pkg Type	-40 to 85	65HVD22	Samples
SN65HVD23D	ACTIVE	SOIC	D	8	75	Green (RoHS & no Sb/Br)	CU NIPDAU	Level-1-260C-UNLIM	-40 to 85	VP23	Samples

Orderable Device	Status (1)	Package Type	Package Drawing	Pins	Package Qty	Eco Plan (2)	Lead/Ball Finish (6)	MSL Peak Temp (3)	Op Temp (°C)	Device Marking (4/5)	Samples
SN65HVD23DG4	ACTIVE	SOIC	D	8	75	Green (RoHS & no Sb/Br)	CU NIPDAU	Level-1-260C-UNLIM	-40 to 85	VP23	Samples
SN65HVD23DR	ACTIVE	SOIC	D	8	2500	Green (RoHS & no Sb/Br)	CU NIPDAU	Level-1-260C-UNLIM	-40 to 85	VP23	Samples
SN65HVD23DRG4	ACTIVE	SOIC	D	8	2500	Green (RoHS & no Sb/Br)	CU NIPDAU	Level-1-260C-UNLIM	-40 to 85	VP23	Samples
SN65HVD23P	ACTIVE	PDIP	P	8	50	Pb-Free (RoHS)	CU NIPDAU	N / A for Pkg Type	-40 to 85	65HVD23	Samples
SN65HVD24D	ACTIVE	SOIC	D	8	75	Green (RoHS & no Sb/Br)	CU NIPDAU	Level-1-260C-UNLIM	-40 to 85	VP24	Samples
SN65HVD24DG4	ACTIVE	SOIC	D	8	75	Green (RoHS & no Sb/Br)	CU NIPDAU	Level-1-260C-UNLIM	-40 to 85	VP24	Samples
SN65HVD24DR	ACTIVE	SOIC	D	8	2500	Green (RoHS & no Sb/Br)	CU NIPDAU	Level-1-260C-UNLIM	-40 to 85	VP24	Samples
SN65HVD24DRG4	ACTIVE	SOIC	D	8	2500	Green (RoHS & no Sb/Br)	CU NIPDAU	Level-1-260C-UNLIM	-40 to 85	VP24	Samples
SN65HVD24P	LIFEBUY	PDIP	P	8	50	Pb-Free (RoHS)	CU NIPDAU	N / A for Pkg Type	-40 to 85	65HVD24	

(1) The marketing status values are defined as follows:

ACTIVE: Product device recommended for new designs.

LIFEBUY: TI has announced that the device will be discontinued, and a lifetime-buy period is in effect.

NRND: Not recommended for new designs. Device is in production to support existing customers, but TI does not recommend using this part in a new design.

PREVIEW: Device has been announced but is not in production. Samples may or may not be available.

OBSELETE: TI has discontinued the production of the device.

(2) **RoHS:** TI defines "RoHS" to mean semiconductor products that are compliant with the current EU RoHS requirements for all 10 RoHS substances, including the requirement that RoHS substance do not exceed 0.1% by weight in homogeneous materials. Where designed to be soldered at high temperatures, "RoHS" products are suitable for use in specified lead-free processes. TI may reference these types of products as "Pb-Free".

RoHS Exempt: TI defines "RoHS Exempt" to mean products that contain lead but are compliant with EU RoHS pursuant to a specific EU RoHS exemption.

Green: TI defines "Green" to mean the content of Chlorine (Cl) and Bromine (Br) based flame retardants meet JS709B low halogen requirements of <=1000ppm threshold. Antimony trioxide based flame retardants must also meet the <=1000ppm threshold requirement.

(3) MSL, Peak Temp. - The Moisture Sensitivity Level rating according to the JEDEC industry standard classifications, and peak solder temperature.

(4) There may be additional marking, which relates to the logo, the lot trace code information, or the environmental category on the device.

⁽⁵⁾ Multiple Device Markings will be inside parentheses. Only one Device Marking contained in parentheses and separated by a "-" will appear on a device. If a line is indented then it is a continuation of the previous line and the two combined represent the entire Device Marking for that device.

⁽⁶⁾ Lead/Ball Finish - Orderable Devices may have multiple material finish options. Finish options are separated by a vertical ruled line. Lead/Ball Finish values may wrap to two lines if the finish value exceeds the maximum column width.

Important Information and Disclaimer:The information provided on this page represents TI's knowledge and belief as of the date that it is provided. TI bases its knowledge and belief on information provided by third parties, and makes no representation or warranty as to the accuracy of such information. Efforts are underway to better integrate information from third parties. TI has taken and continues to take reasonable steps to provide representative and accurate information but may not have conducted destructive testing or chemical analysis on incoming materials and chemicals. TI and TI suppliers consider certain information to be proprietary, and thus CAS numbers and other limited information may not be available for release.

In no event shall TI's liability arising out of such information exceed the total purchase price of the TI part(s) at issue in this document sold by TI to Customer on an annual basis.

TAPE AND REEL INFORMATION



QUADRANT ASSIGNMENTS FOR PIN 1 ORIENTATION IN TAPE



*All dimensions are nominal

Device	Package Type	Package Drawing	Pins	SPQ	Reel Diameter (mm)	Reel Width W1 (mm)	A0 (mm)	B0 (mm)	K0 (mm)	P1 (mm)	W (mm)	Pin1 Quadrant
SN65HVD20DR	SOIC	D	8	2500	330.0	12.4	6.4	5.2	2.1	8.0	12.0	Q1
SN65HVD21DR	SOIC	D	8	2500	330.0	12.4	6.4	5.2	2.1	8.0	12.0	Q1
SN65HVD22DR	SOIC	D	8	2500	330.0	12.4	6.4	5.2	2.1	8.0	12.0	Q1
SN65HVD23DR	SOIC	D	8	2500	330.0	12.4	6.4	5.2	2.1	8.0	12.0	Q1
SN65HVD24DR	SOIC	D	8	2500	330.0	12.4	6.4	5.2	2.1	8.0	12.0	Q1

TAPE AND REEL BOX DIMENSIONS

*All dimensions are nominal

Device	Package Type	Package Drawing	Pins	SPQ	Length (mm)	Width (mm)	Height (mm)
SN65HVD20DR	SOIC	D	8	2500	340.5	338.1	20.6
SN65HVD21DR	SOIC	D	8	2500	340.5	338.1	20.6
SN65HVD22DR	SOIC	D	8	2500	340.5	338.1	20.6
SN65HVD23DR	SOIC	D	8	2500	340.5	338.1	20.6
SN65HVD24DR	SOIC	D	8	2500	340.5	338.1	20.6

D (R-PDSO-G8)

PLASTIC SMALL OUTLINE

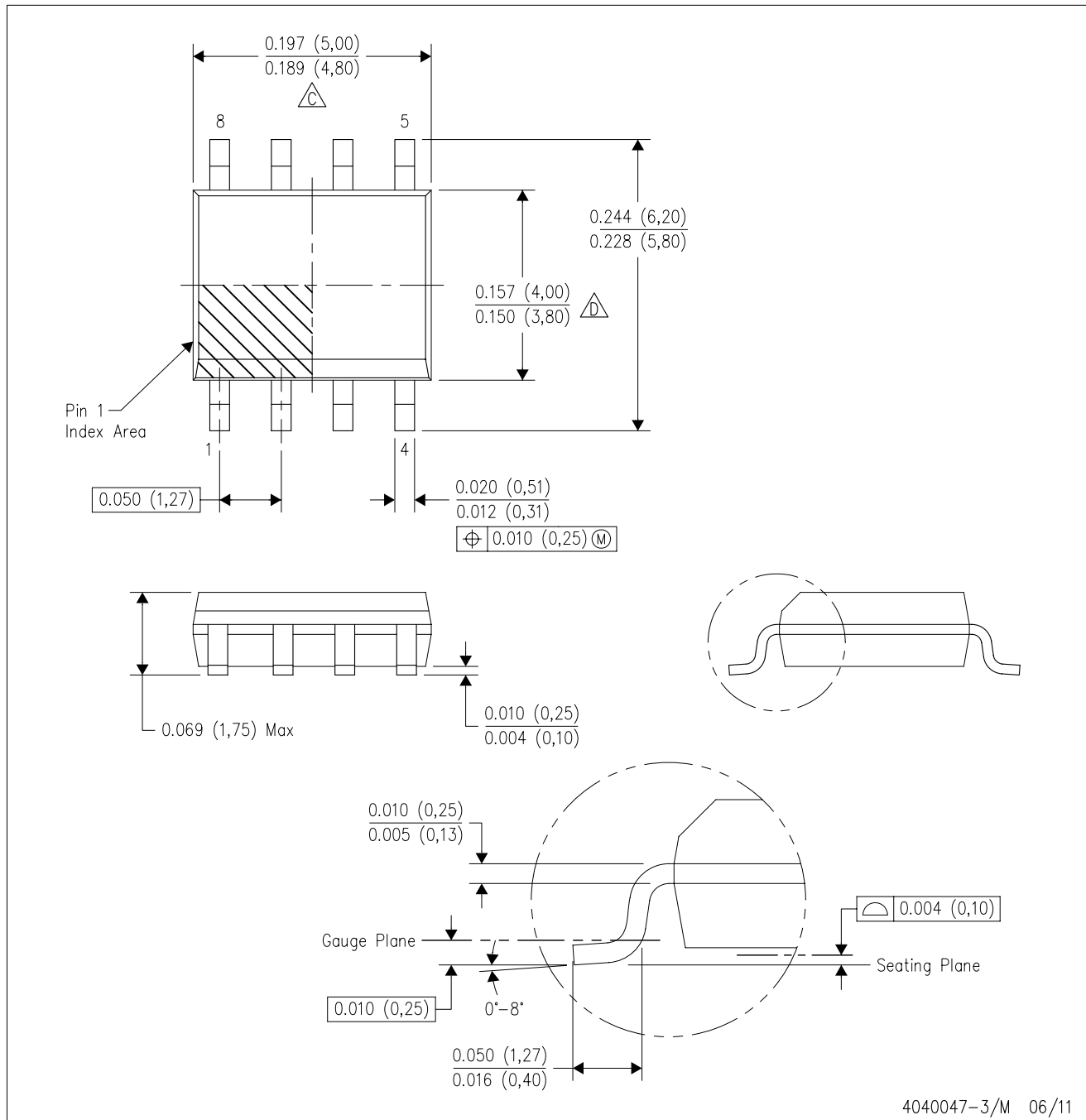

NOTES: A. All linear dimensions are in inches (millimeters).
 B. This drawing is subject to change without notice.
 C. Body length does not include mold flash, protrusions, or gate burrs. Mold flash, protrusions, or gate burrs shall not exceed 0.006 (0,15) each side.
 D. Body width does not include interlead flash. Interlead flash shall not exceed 0.017 (0,43) each side.
 E. Reference JEDEC MS-012 variation AA.

P (R-PDIP-T8)

PLASTIC DUAL-IN-LINE PACKAGE



4040082/E 04/2010

IMPORTANT NOTICE

Texas Instruments Incorporated (TI) reserves the right to make corrections, enhancements, improvements and other changes to its semiconductor products and services per JESD46, latest issue, and to discontinue any product or service per JESD48, latest issue. Buyers should obtain the latest relevant information before placing orders and should verify that such information is current and complete.

TI's published terms of sale for semiconductor products (<http://www.ti.com/sc/docs/stdterms.htm>) apply to the sale of packaged integrated circuit products that TI has qualified and released to market. Additional terms may apply to the use or sale of other types of TI products and services.

Reproduction of significant portions of TI information in TI data sheets is permissible only if reproduction is without alteration and is accompanied by all associated warranties, conditions, limitations, and notices. TI is not responsible or liable for such reproduced documentation. Information of third parties may be subject to additional restrictions. Resale of TI products or services with statements different from or beyond the parameters stated by TI for that product or service voids all express and any implied warranties for the associated TI product or service and is an unfair and deceptive business practice. TI is not responsible or liable for any such statements.

Buyers and others who are developing systems that incorporate TI products (collectively, "Designers") understand and agree that Designers remain responsible for using their independent analysis, evaluation and judgment in designing their applications and that Designers have full and exclusive responsibility to assure the safety of Designers' applications and compliance of their applications (and of all TI products used in or for Designers' applications) with all applicable regulations, laws and other applicable requirements. Designer represents that, with respect to their applications, Designer has all the necessary expertise to create and implement safeguards that (1) anticipate dangerous consequences of failures, (2) monitor failures and their consequences, and (3) lessen the likelihood of failures that might cause harm and take appropriate actions. Designer agrees that prior to using or distributing any applications that include TI products, Designer will thoroughly test such applications and the functionality of such TI products as used in such applications.

TI's provision of technical, application or other design advice, quality characterization, reliability data or other services or information, including, but not limited to, reference designs and materials relating to evaluation modules, (collectively, "TI Resources") are intended to assist designers who are developing applications that incorporate TI products; by downloading, accessing or using TI Resources in any way, Designer (individually or, if Designer is acting on behalf of a company, Designer's company) agrees to use any particular TI Resource solely for this purpose and subject to the terms of this Notice.

TI's provision of TI Resources does not expand or otherwise alter TI's applicable published warranties or warranty disclaimers for TI products, and no additional obligations or liabilities arise from TI providing such TI Resources. TI reserves the right to make corrections, enhancements, improvements and other changes to its TI Resources. TI has not conducted any testing other than that specifically described in the published documentation for a particular TI Resource.

Designer is authorized to use, copy and modify any individual TI Resource only in connection with the development of applications that include the TI product(s) identified in such TI Resource. NO OTHER LICENSE, EXPRESS OR IMPLIED, BY ESTOPPEL OR OTHERWISE TO ANY OTHER TI INTELLECTUAL PROPERTY RIGHT, AND NO LICENSE TO ANY TECHNOLOGY OR INTELLECTUAL PROPERTY RIGHT OF TI OR ANY THIRD PARTY IS GRANTED HEREIN, including but not limited to any patent right, copyright, mask work right, or other intellectual property right relating to any combination, machine, or process in which TI products or services are used. Information regarding or referencing third-party products or services does not constitute a license to use such products or services, or a warranty or endorsement thereof. Use of TI Resources may require a license from a third party under the patents or other intellectual property of the third party, or a license from TI under the patents or other intellectual property of TI.

TI RESOURCES ARE PROVIDED "AS IS" AND WITH ALL FAULTS. TI DISCLAIMS ALL OTHER WARRANTIES OR REPRESENTATIONS, EXPRESS OR IMPLIED, REGARDING RESOURCES OR USE THEREOF, INCLUDING BUT NOT LIMITED TO ACCURACY OR COMPLETENESS, TITLE, ANY EPIDEMIC FAILURE WARRANTY AND ANY IMPLIED WARRANTIES OF MERCHANTABILITY, FITNESS FOR A PARTICULAR PURPOSE, AND NON-INFRINGEMENT OF ANY THIRD PARTY INTELLECTUAL PROPERTY RIGHTS. TI SHALL NOT BE LIABLE FOR AND SHALL NOT DEFEND OR INDEMNIFY DESIGNER AGAINST ANY CLAIM, INCLUDING BUT NOT LIMITED TO ANY INFRINGEMENT CLAIM THAT RELATES TO OR IS BASED ON ANY COMBINATION OF PRODUCTS EVEN IF DESCRIBED IN TI RESOURCES OR OTHERWISE. IN NO EVENT SHALL TI BE LIABLE FOR ANY ACTUAL, DIRECT, SPECIAL, COLLATERAL, INDIRECT, PUNITIVE, INCIDENTAL, CONSEQUENTIAL OR EXEMPLARY DAMAGES IN CONNECTION WITH OR ARISING OUT OF TI RESOURCES OR USE THEREOF, AND REGARDLESS OF WHETHER TI HAS BEEN ADVISED OF THE POSSIBILITY OF SUCH DAMAGES.

Unless TI has explicitly designated an individual product as meeting the requirements of a particular industry standard (e.g., ISO/TS 16949 and ISO 26262), TI is not responsible for any failure to meet such industry standard requirements.

Where TI specifically promotes products as facilitating functional safety or as compliant with industry functional safety standards, such products are intended to help enable customers to design and create their own applications that meet applicable functional safety standards and requirements. Using products in an application does not by itself establish any safety features in the application. Designers must ensure compliance with safety-related requirements and standards applicable to their applications. Designer may not use any TI products in life-critical medical equipment unless authorized officers of the parties have executed a special contract specifically governing such use. Life-critical medical equipment is medical equipment where failure of such equipment would cause serious bodily injury or death (e.g., life support, pacemakers, defibrillators, heart pumps, neurostimulators, and implantables). Such equipment includes, without limitation, all medical devices identified by the U.S. Food and Drug Administration as Class III devices and equivalent classifications outside the U.S.

TI may expressly designate certain products as completing a particular qualification (e.g., Q100, Military Grade, or Enhanced Product). Designers agree that it has the necessary expertise to select the product with the appropriate qualification designation for their applications and that proper product selection is at Designers' own risk. Designers are solely responsible for compliance with all legal and regulatory requirements in connection with such selection.

Designer will fully indemnify TI and its representatives against any damages, costs, losses, and/or liabilities arising out of Designer's non-compliance with the terms and provisions of this Notice.

Looking for pricing, stock, or lifecycle information?

Click below to explore more details on WIN SOURCE:

 [View SN65HVD20P on WIN SOURCE](#)

 [Texas Instruments](#) Information

Optimize Your Supply Chain with WIN SOURCE Solutions

-  Global Sourcing Solution
-  Obsolete Management
-  Cost Control Management
-  Shortage Management
-  Alternative Solution
-  Excess Inventory Management