



# THE DATASHEET OF M74HC4016RM13TR





# M74HC4016

## QUAD BILATERAL SWITCH

- HIGH SPEED:  
 $t_{PD} = 9ns$  (TYP.) at  $V_{CC} = 6V$
- LOW POWER DISSIPATION:  
 $I_{CC} = 1\mu A$  (MAX.) at  $T_A = 25^\circ C$
- LOW "ON" RESISTANCE:  
 $R_{ON} = 60\Omega$  TYP. AT  $V_{CC} = 9V, I_{I/O} = 100\mu A$
- WIDE OPERATING VOLTAGE RANGE  
 $V_{CC}$  (OPR) = 2V TO 12V
- SINE WAVE DISTORTION:  
 $0.042\%$  at  $V_{CC} = 9V_{pp}, f = 1KHz$
- HIGH NOISE IMMUNITY:  
 $V_{NIH} = V_{NIL} = 28\% V_{CC}$  (MIN.)
- PIN AND FUNCTION COMPATIBLE WITH  
 74 SERIES 4016

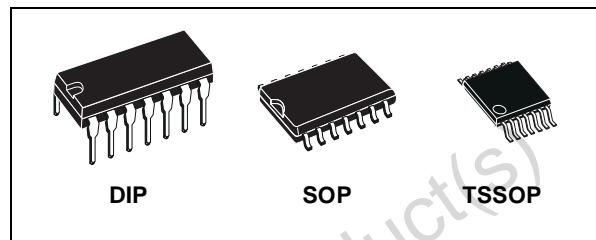

### ORDER CODES

PACKAGE	TUBE	T & R
DIP	M74HC4016B1R	
SOP	M74HC4016M1R	M74HC4016RM13TR
TSSOP		M74HC4016TTR

### DESCRIPTION

The M74HC4016 is an high speed CMOS QUAD BILATERAL SWITCH fabricated with silicon gate C<sup>2</sup>MOS technology.

The C input is provided to control the switch; the switch is on when the C input is held high and off when C is held low.

### PIN CONNECTION AND LOGIC SYMBOLS

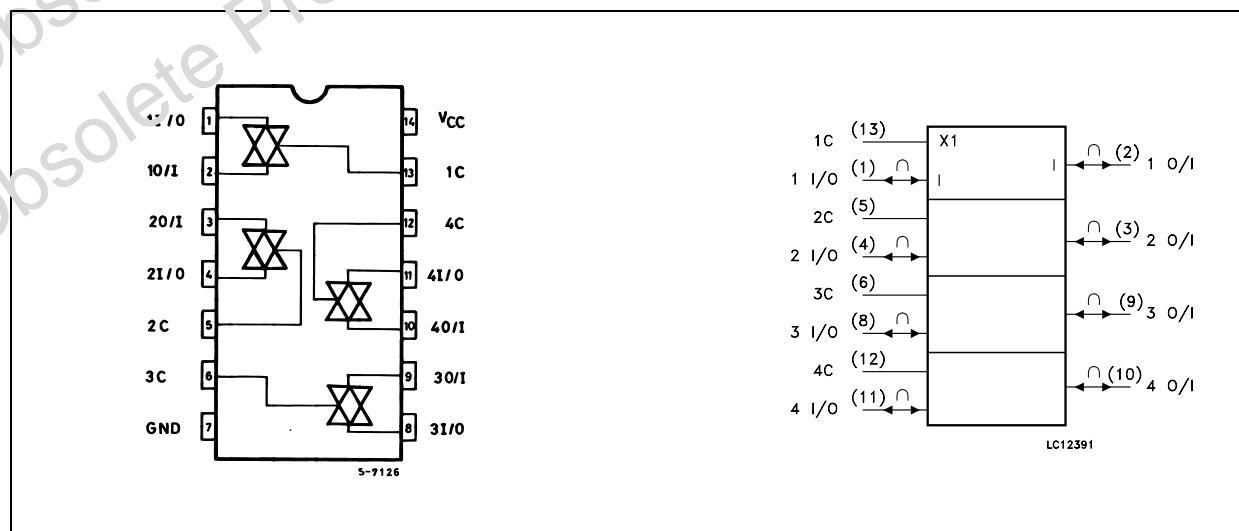

**LOGIC DIAGRAM**

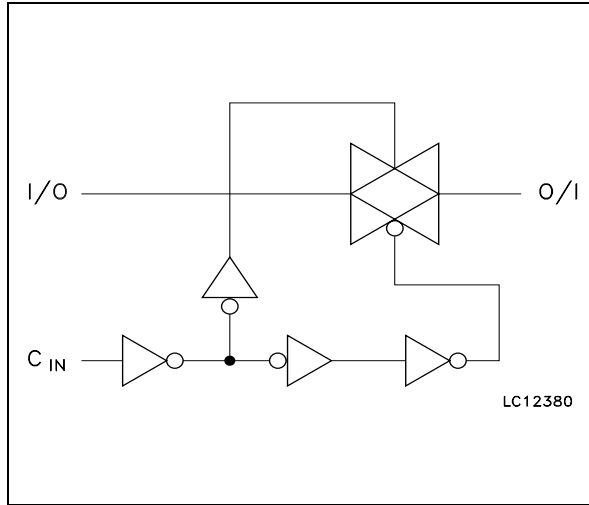

**PIN DESCRIPTION**

PIN No	SYMBOL	NAME AND FUNCTION
1, 4, 8, 11	1 to 4 I/O	Independent Inputs/Outputs
2, 3, 9, 10	1 to 4 O/I	Independent Outputs/Inputs
13, 5, 6, 12	1C to 4C	Enable Inputs (Active High)
7	GND	Ground (0V)
14	V <sub>CC</sub>	Positive Supply Voltage

**TRUTH TABLE**

CONTROL	SWITCH FUNCTION
H	ON
L	OFF

**ABSOLUTE MAXIMUM RATINGS**

Symbol	Parameter	Value	Unit
V <sub>CC</sub>	Supply Voltage	-0.5 to +13	V
V <sub>IN</sub>	DC Input Voltage	-0.5 to V <sub>CC</sub> + 0.5	V
V <sub>I/O</sub>	DC Input/Output Voltage	-0.5 to V <sub>CC</sub> + 0.5	V
I <sub>OK</sub>	Control Input DC Diode Current	± 20	mA
I <sub>I/O</sub>	I/O DC Diode Current	± 20	mA
I <sub>O</sub>	DC Output Source Sink Current Per Output Pin	± 25	mA
I <sub>CC</sub> or I <sub>GND</sub>	DC V <sub>CC</sub> or Ground Current	± 50	mA
P <sub>D</sub>	Power Dissipation	500(*)	mW
T <sub>stg</sub>	Storage Temperature	-65 to +150	°C
T <sub>L</sub>	Lead Temperature (10 sec)	300	°C

Absolute Maximum Ratings are those values beyond which damage to the device may occur. Functional operation under these conditions is not implied  
 (\*) 500mW at 65 °C; derate to 300mW by 10mW/°C from 65°C to 85°C

**RECOMMENDED OPERATING CONDITIONS**

Symbol	Parameter	Value	Unit	
V <sub>CC</sub>	Supply Voltage	2 to 12	V	
V <sub>IN</sub>	Input Voltage (Control)	0 to V <sub>CC</sub>	V	
V <sub>I/O</sub>	I/O Voltage	0 to V <sub>CC</sub>	V	
T <sub>op</sub>	Operating Temperature	-55 to 125	°C	
t <sub>r</sub> , t <sub>f</sub>	Input Rise and Fall Time	V <sub>CC</sub> = 2.0V	0 to 1000	ns
		V <sub>CC</sub> = 4.5V	0 to 500	
		V <sub>CC</sub> = 6.0V	0 to 400	
		V <sub>CC</sub> = 10.0V	0 to 250	

## DC SPECIFICATIONS

Symbol	Parameter	Test Condition		Value						Unit	
		V <sub>CC</sub> (V)		T <sub>A</sub> = 25°C			-40 to 85°C		-55 to 125°C		
				Min.	Typ.	Max.	Min.	Max.	Min.		Max.
V <sub>IHC</sub>	High Level Control Input Voltage	2.0		1.5			1.5		1.5		V
		4.5		3.15			3.15		3.15		
		9.0		6.3			6.3		6.3		
		12.0		8.4			8.4		8.4		
V <sub>ILC</sub>	Low Level Control Input Voltage	2.0				0.5		0.5		0.5	V
		4.5				1.35		1.35		1.35	
		9.0				2.5		2.5		2.5	
		12.0				3.6		3.6		3.6	
R <sub>ON</sub>	ON Resistance	4.5	V <sub>IN</sub> = V <sub>IHC</sub>		160	320		400		450	Ω
		9.0	V <sub>I/O</sub> = V <sub>CC</sub> to GND		85	170		213		260	
		12.0	I <sub>I/O</sub> = 100μA		60	120		150		180	
		4.5	V <sub>IN</sub> = V <sub>IHC</sub>		80	160		200		250	
		9.0	V <sub>I/O</sub> = V <sub>CC</sub> or GND		60	120		150		200	
		12.0	I <sub>I/O</sub> = 100μA		50	100		125		150	
ΔR <sub>ON</sub>	Difference of ON Resistance between switches	4.5	V <sub>IN</sub> = V <sub>IHC</sub>		16						Ω
		9.0	V <sub>I/O</sub> = V <sub>CC</sub> or GND		9						
		12.0	I <sub>I/O</sub> ≤ 100μA		6						
I <sub>OFF</sub>	Input/Output Leakage Current (SWITCH OFF)	12.0	V <sub>OS</sub> = V <sub>CC</sub> or GND V <sub>IS</sub> = V <sub>CC</sub> or GND V <sub>IN</sub> = V <sub>ILC</sub>			± 0.1		± 1		± 2	μA
I <sub>Iz</sub>	Switch Input Leakage Current (SWITCH ON, OUTPUT OPEN)	12.0	V <sub>OS</sub> = V <sub>CC</sub> or GND V <sub>IN</sub> = V <sub>IHC</sub>			± 0.1		± 1		± 2	μA
I <sub>IN</sub>	Control Input Current	6.0	V <sub>IN</sub> = V <sub>CC</sub> or GND			± 0.1		± 1		± 1	μA
I <sub>CC</sub>	Quiescent Supply Current	6.0				1		10		20	μA
		9.0	V <sub>IN</sub> = V <sub>CC</sub> or GND			4		40		80	
		12.0				8		80		160	

**AC ELECTRICAL CHARACTERISTICS** ( $C_L = 50 \text{ pF}$ , Input  $t_r = t_f = 6 \text{ ns}$ )

Symbol	Parameter	Test Condition		Value						Unit	
		$V_{CC}$ (V)		$T_A = 25^\circ\text{C}$			$-40 \text{ to } 85^\circ\text{C}$		$-55 \text{ to } 125^\circ\text{C}$		
				Min.	Typ.	Max.	Min.	Max.	Min.		Max.
$\Phi_{I/O}$	Phase Difference Between Input and Output	2.0			20	50		65		75	ns
		4.5			5	10		13		15	
		9.0			4	8		10		12	
		12.0			3	7		9		11	
$t_{PZL}$ $t_{PZH}$	Output Enable Time	2.0	$R_L = 1\text{K}\Omega$		40	100		125		150	ns
		4.5			10	20		25		30	
		9.0			8	15		20		24	
		12.0			7	14		18		21	
$t_{PLZ}$ $t_{PHZ}$	Output Disable Time	2.0	$R_L = 1\text{K}\Omega$		60	150		190		225	ns
		4.5			15	30		38		45	
		9.0			10	26		33		36	
		12.0			8	24		30		32	

**CAPACITIVE CHARACTERISTICS**

Symbol	Parameter	Test Condition		Value						Unit	
		$V_{CC}$ (V)		$T_A = 25^\circ\text{C}$			$-40 \text{ to } 85^\circ\text{C}$		$-55 \text{ to } 125^\circ\text{C}$		
				Min.	Typ.	Max.	Min.	Max.	Min.		Max.
$C_{IN}$	Input Capacitance				5	10		10		10	pF
$C_{I/O}$	Switch Terminal Capacitance				5						pF
$C_{IOS}$	Feed Through Capacitance				1						pF
$C_{PD}$	Power Dissipation Capacitance (note 1)				15						pF

1)  $C_{PD}$  is defined as the value of the IC's internal equivalent capacitance which is calculated from the operating current consumption without load. (Refer to Test Circuit). Average operating current can be obtained by the following equation.  $I_{CC(oper)} = C_{PD} \times V_{CC} \times f_{IN} + I_{CC}$

ANALOG SWITCH CHARACTERISTICS (GND = 0V; T<sub>A</sub> = 25°C)

Symbol	Parameter	Test Condition		Value	Unit	
		V <sub>CC</sub> (V)	V <sub>IN</sub> (V <sub>p-p</sub> )	Typ.		
	Sine Wave Distortion (THD)	4.5	4.5	f <sub>IN</sub> = 1 KHz R <sub>L</sub> = 10 KΩ, C <sub>L</sub> = 50 pF	0.118	%
		9.0	9.0		0.042	
		12.0	12.0		0.032	
f <sub>MAX</sub>	Frequency Response (Switch ON)	4.5	Adjust f <sub>IN</sub> voltage to obtain 0 dBm at V <sub>OS</sub> . Increase f <sub>IN</sub> Frequency until dB meter reads -3dB R <sub>L</sub> = 50Ω, C <sub>L</sub> = 50 pF	23	MHz	
		9.0		38		
		12.0		42		
	Feed through Attenuation (Switch OFF)	4.5	V <sub>IN</sub> is centered at V <sub>CC</sub> /2. Adjust input for 0 dBm R <sub>L</sub> = 600Ω C <sub>L</sub> = 50 pF, f <sub>IN</sub> = 1MHz sine wave	-50	dB	
		9.0		-50		
		12.0		-50		
	Crosstalk (Control Input to Signal Output)	4.5	R <sub>L</sub> = 600Ω, C <sub>L</sub> = 50 pF, f <sub>IN</sub> = 1MHz square wave (t <sub>r</sub> = t <sub>f</sub> = 6ns)	8	mV	
		9.0		23		
		12.0		40		
	Crosstalk (Between Any Switches)	4.5	Adjust V <sub>IN</sub> to Obtain 0 dBm at input R <sub>L</sub> = 600Ω, C <sub>L</sub> = 50 pF, f <sub>IN</sub> = 1MHz sine wave	-50	dB	
		9.0		-50		
		12.0		-50		

SWITCHING CHARACTERISTICS TEST CIRCUIT

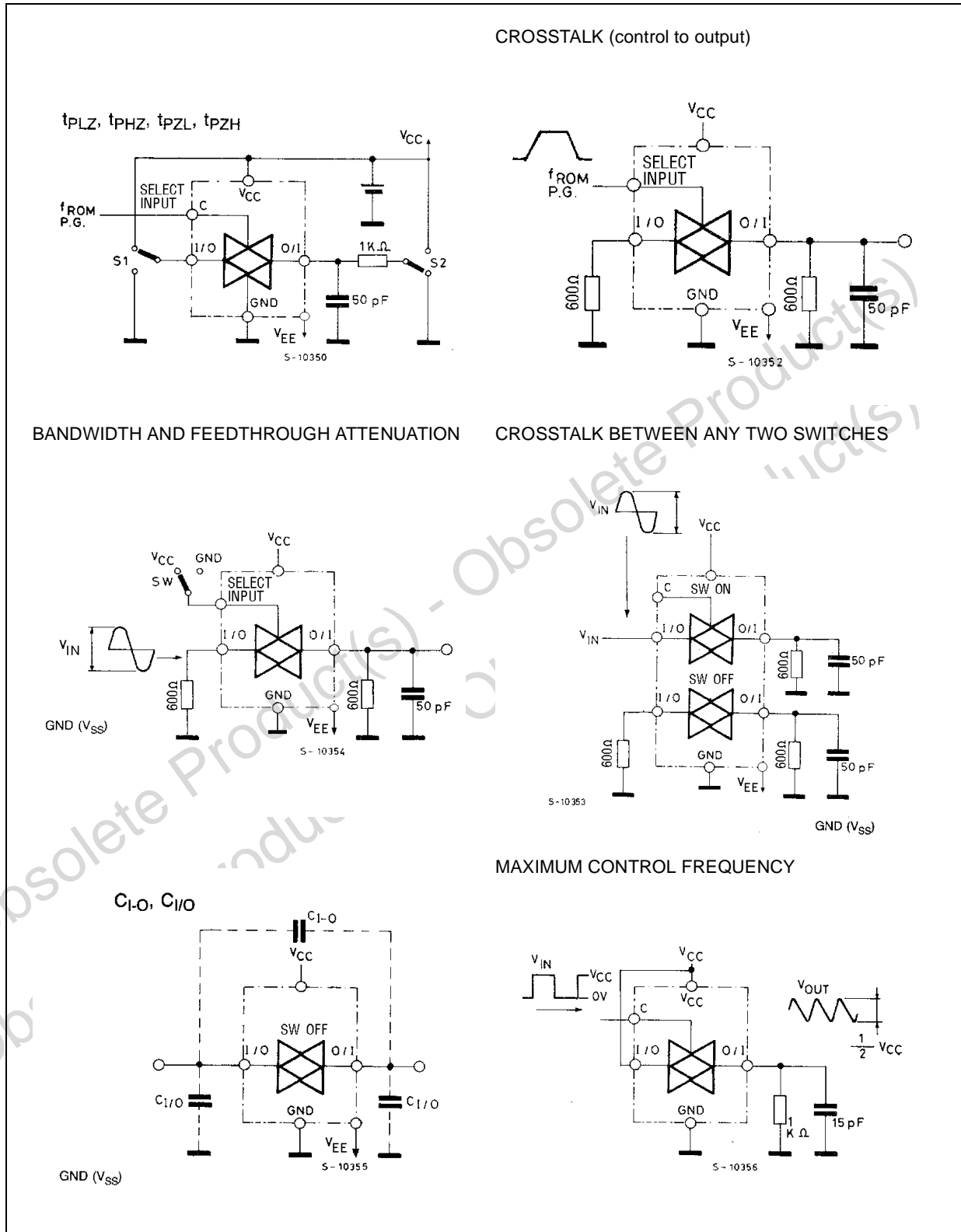

CHANNEL RESISTANCE ( $R_{ON}$ )

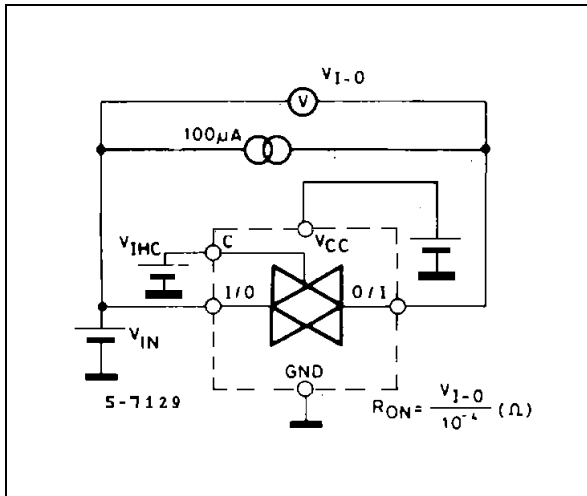

$I_{CC}$  (Opr.)

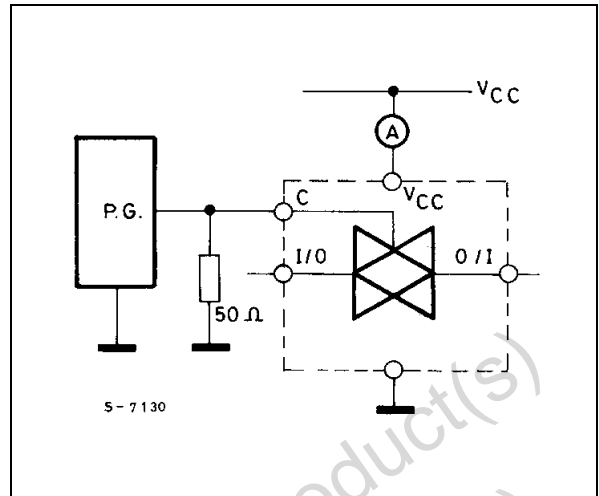

Obsolete Product(s) - Obsolete Product(s)  
 Obsolete Product(s) - Obsolete Product(s)

**Plastic DIP-14 MECHANICAL DATA**

DIM.	mm.			inch		
	MIN.	TYP	MAX.	MIN.	TYP.	MAX.
a1	0.51			0.020		
B	1.39		1.65	0.055		0.065
b		0.5			0.020	
b1		0.25			0.010	
D			20			0.787
E		8.5			0.335	
e		2.54			0.100	
e3		15.24			0.600	
F			7.1			0.280
I			5.1			0.201
L		3.3			0.130	
Z	1.27		2.54	0.050		0.100

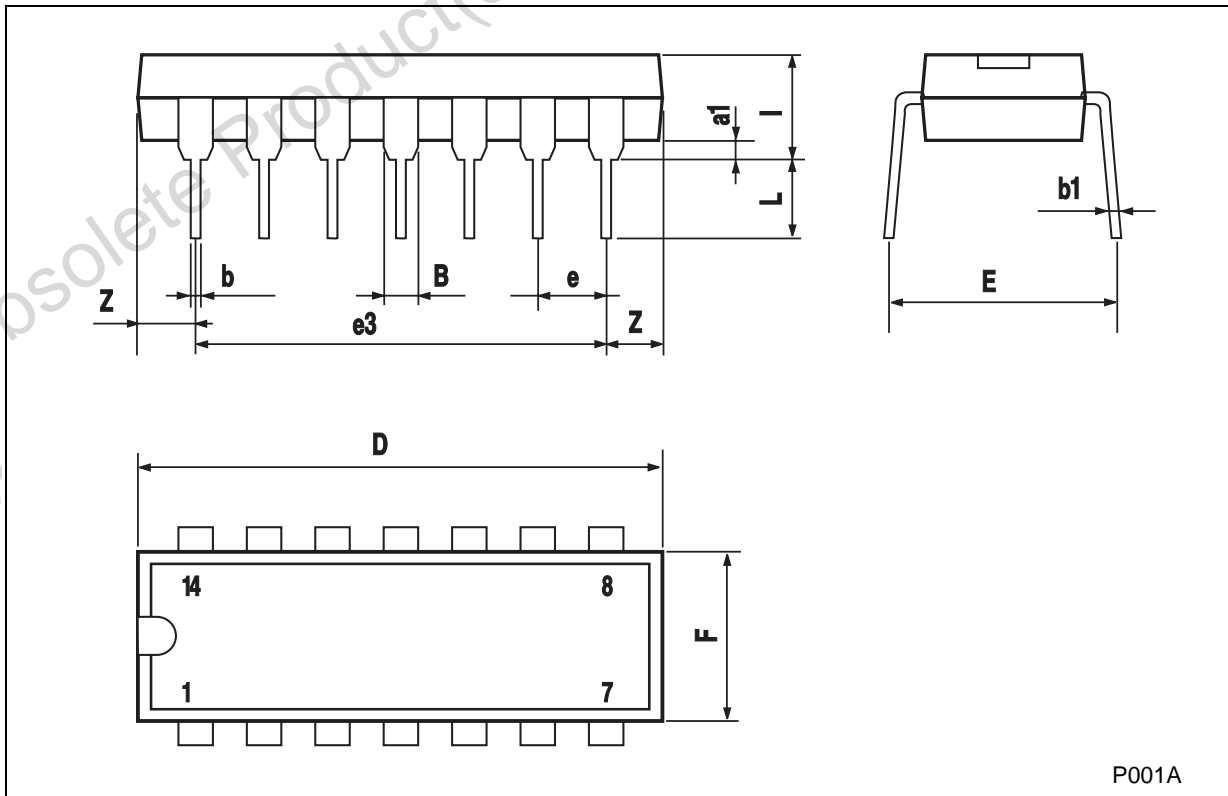

P001A

## SO-14 MECHANICAL DATA

DIM.	mm.			inch		
	MIN.	TYP.	MAX.	MIN.	TYP.	MAX.
A			1.75			0.068
a1	0.1		0.2	0.003		0.007
a2			1.65			0.064
b	0.35		0.46	0.013		0.018
b1	0.19		0.25	0.007		0.010
C		0.5			0.019	
c1	45° (typ.)					
D	8.55		8.75	0.336		0.344
E	5.8		6.2	0.228		0.244
e		1.27			0.050	
e3		7.62			0.300	
F	3.8		4.0	0.149		0.157
G	4.6		5.3	0.181		0.208
L	0.5		1.27	0.019		0.050
M			0.68			0.026
S	8° (max.)					

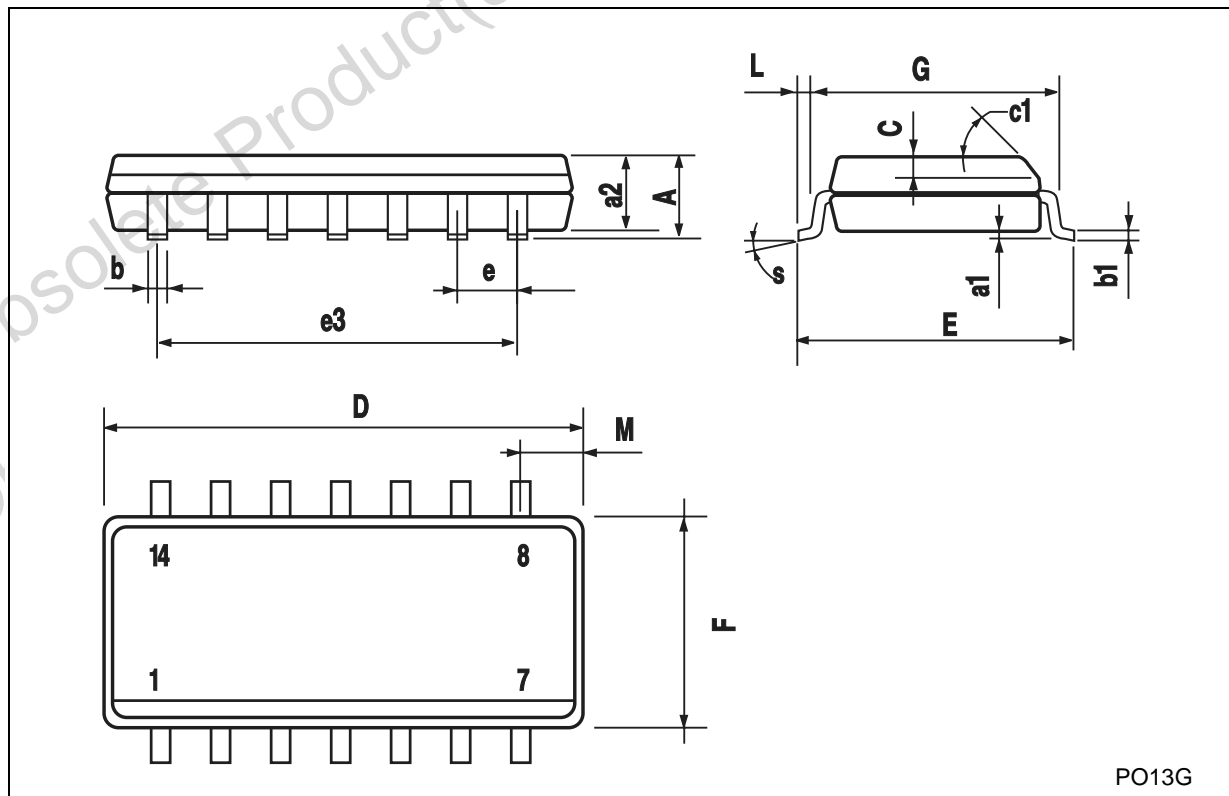

PO13G

**TSSOP14 MECHANICAL DATA**

DIM.	mm.			inch		
	MIN.	TYP	MAX.	MIN.	TYP.	MAX.
A			1.2			0.047
A1	0.05		0.15	0.002	0.004	0.006
A2	0.8	1	1.05	0.031	0.039	0.041
b	0.19		0.30	0.007		0.012
c	0.09		0.20	0.004		0.0089
D	4.9	5	5.1	0.193	0.197	0.201
E	6.2	6.4	6.6	0.244	0.252	0.260
E1	4.3	4.4	4.48	0.169	0.173	0.176
e		0.65 BSC			0.0256 BSC	
K	0°		8°	0°		8°
L	0.45	0.60	0.75	0.018	0.024	0.030

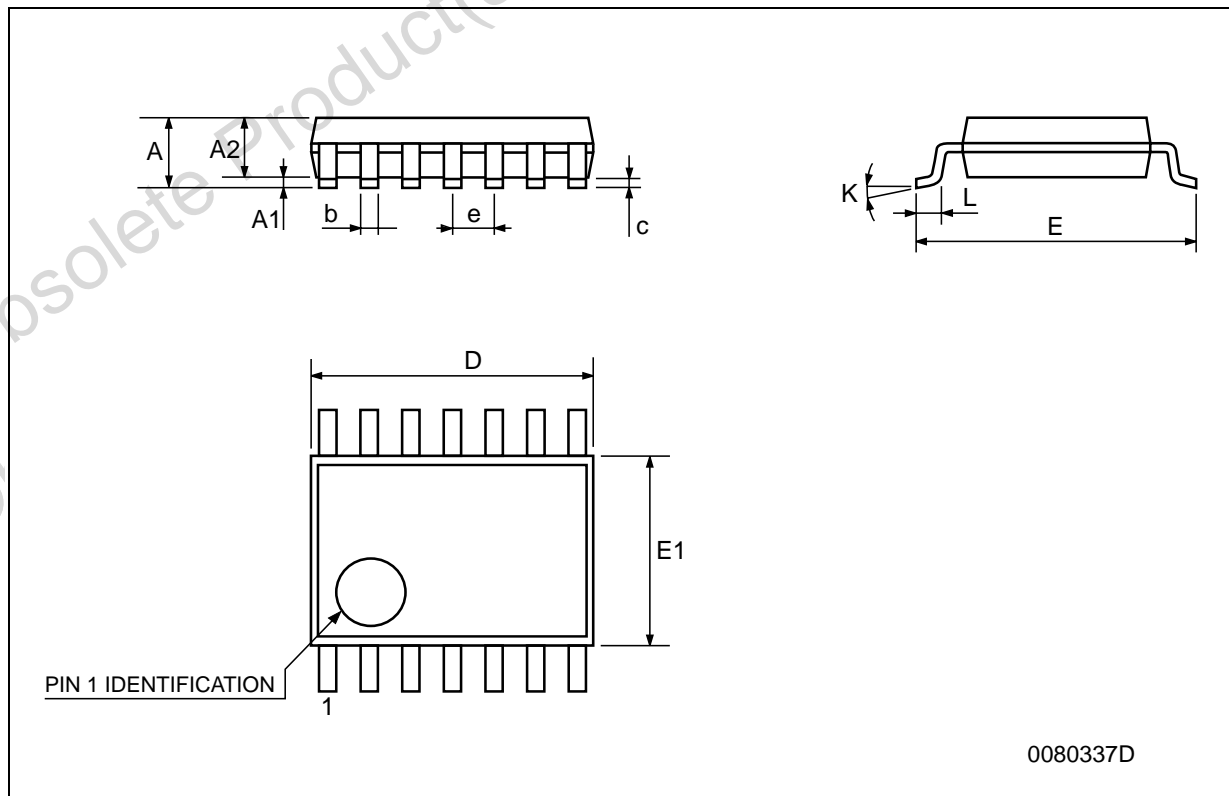

Obsolete Product(s) - Obsolete Product(s)  
Obsolete Product(s) - Obsolete Product(s)

Information furnished is believed to be accurate and reliable. However, STMicroelectronics assumes no responsibility for the consequences of use of such information nor for any infringement of patents or other rights of third parties which may result from its use. No license is granted by implication or otherwise under any patent or patent rights of STMicroelectronics. Specifications mentioned in this publication are subject to change without notice. This publication supersedes and replaces all information previously supplied. STMicroelectronics products are not authorized for use as critical components in life support devices or systems without express written approval of STMicroelectronics.

© The ST logo is a registered trademark of STMicroelectronics

© 2001 STMicroelectronics - Printed in Italy - All Rights Reserved  
STMicroelectronics GROUP OF COMPANIES



Australia - Brazil - China - Finland - France - Germany - Hong Kong - India - Italy - Japan - Malaysia - Malta - Morocco  
Singapore - Spain - Sweden - Switzerland - United Kingdom

© <http://www.st.com>



## Looking for pricing, stock, or lifecycle information?

Click below to explore more details on WIN SOURCE:

-  [View M74HC4016RM13TR on WIN SOURCE](#)
-  [STMicroelectronics](#) Information

## Optimize Your Supply Chain with WIN SOURCE Solutions

-  Global Sourcing Solution
-  Obsolete Management
-  Cost Control Management
-  Shortage Management
-  Alternative Solution
-  Excess Inventory Management