

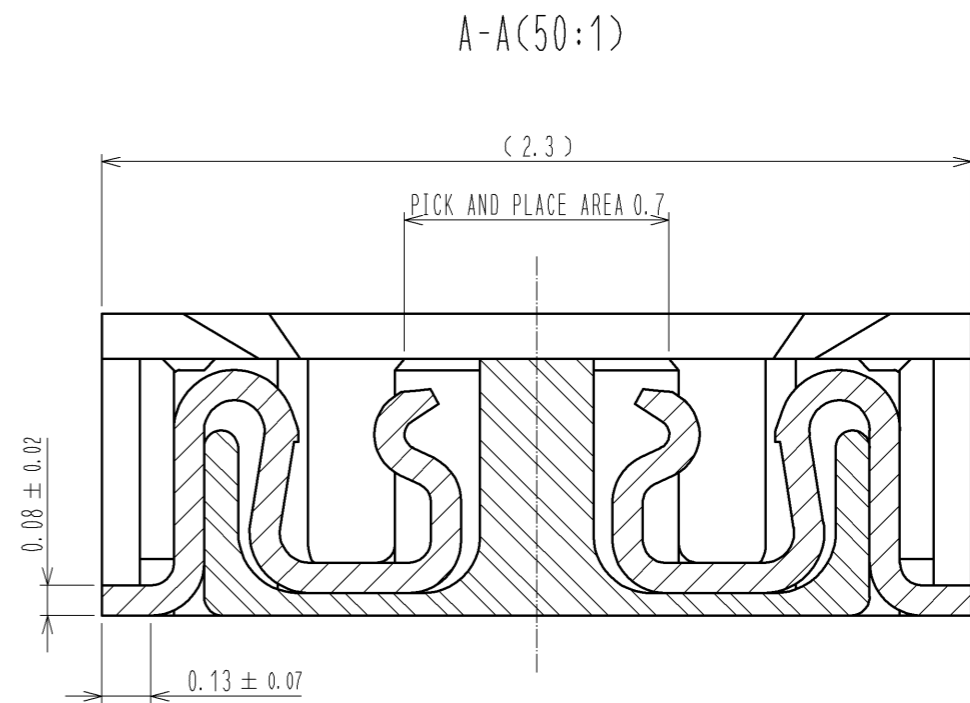

**THE DATASHEET OF
BM20B(0.8)-34DS-0.4V(51)**

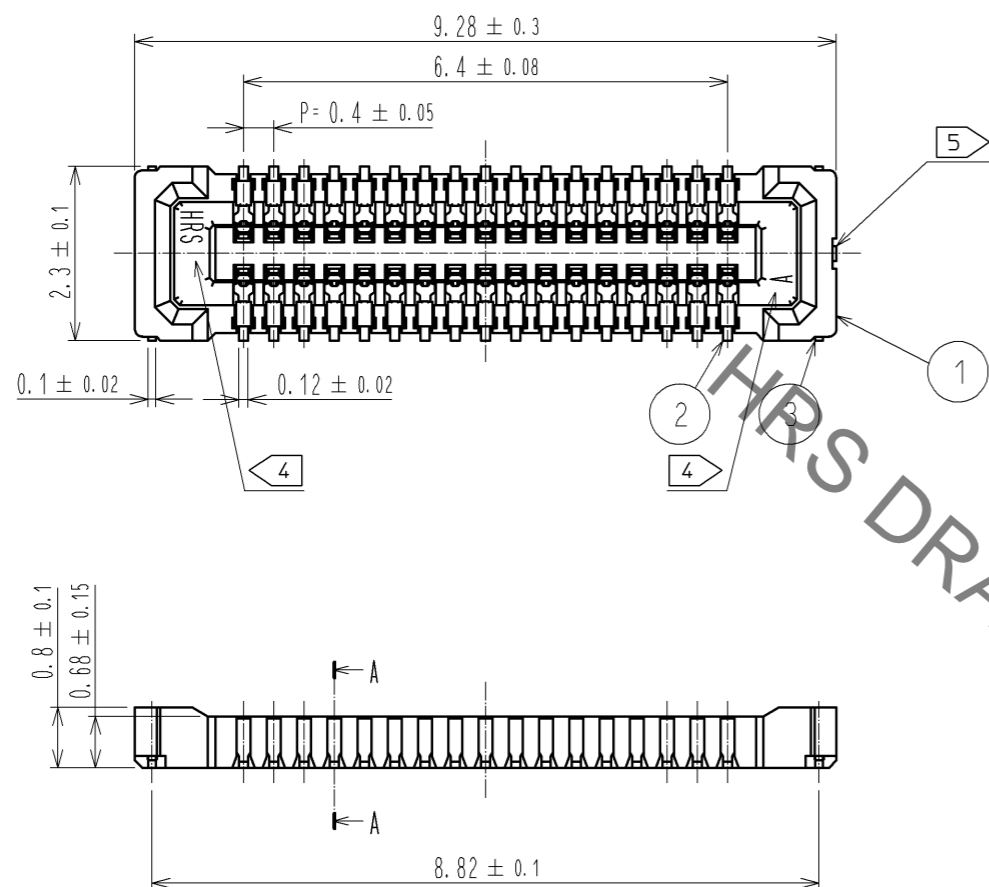

Sep.1.2019 Copyright 2019 HIROSE ELECTRIC CO., LTD. All Rights Reserved.
 In case of consideration for using Automotive equipment / device which demand high reliability, kindly contact our sales window correspondents.



ENGAGEMENT FIGURE (50:1)

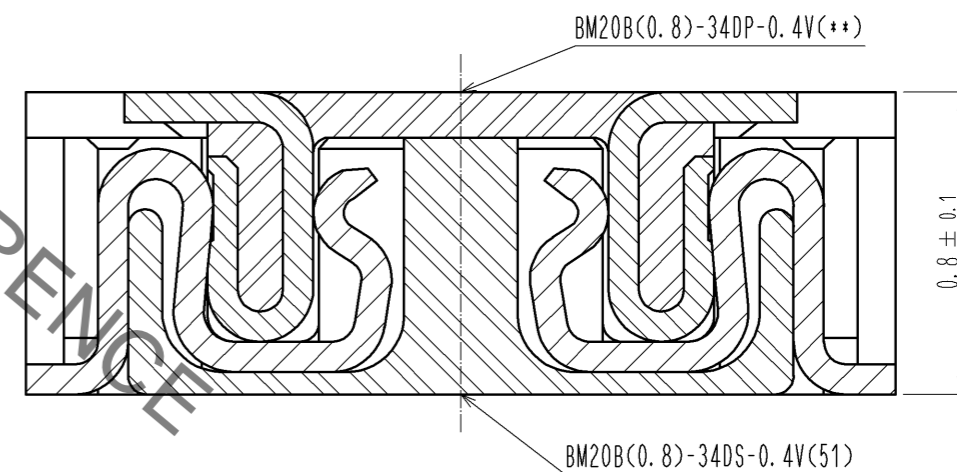

- NOTE 1 . ALL LEAD CO-PLANARITY SHALL BE 0.08mm MAX
- 2 CONTACT PLATING SPECIFICATIONS
 CONTACT AREA : GOLD 0.05 μm MIN
 SMT LEAD : GOLD 0.05 μm MIN
 UNDERPLATING : NICKEL 1 μm MIN
 (SURFACE : SEALING)
- 3 METAL FITTING PLATING SPECIFICATIONS
 SMT LEAD : GOLD 0.05 μm MIN
 UNDERPLATING : NICKEL 1 μm MIN
 (SURFACE : SEALING)
- 4 HRS MARK AND CAV NO. ARE INDICATED IN APPROX POSITION SHOWN.
- 5 GATE POSITION IS INDICATED IN APPROX POSITION SHOWN.

NO.	MATERIAL	FINISH .	REMARKS	NO.	MATERIAL	FINISH .	REMARKS
4	PS		CLEAR (EMBOSSED CARRIER TAPE)	7	PS		CLEAR (REINFORCEMENT COLLAR)
3	BRASS	3		6	PS		BLACK (PLASTIC REEL)
2	PHOSPHOR BRONZE	2		5	POLYESTER		CLEAR (COVER TAPE)
1	LCP		UL94 V-0, BLACK				

UNITS	SCALE	COUNT	DESCRIPTION OF REVISIONS	DESIGNED	CHECKED	DATE
mm	10:1	△				
APPROVED : KH. IKEDA			12.03.15	DRAWING NO. EDC3-343536-01		
CHECKED : TS. MIYAZAKI			12.03.15	PART NO. BM20B(0.8)-34DS-0.4V(51)		
DESIGNED : YK. SATAKE			12.03.14	CODE NO. CL684-9020-0-51		
DRAWN : KR. AJITO			12.03.14	1/3		

Sep.1.2019 Copyright 2019 HIROSE ELECTRIC CO., LTD. All Rights Reserved.
 In case of consideration for using Automotive equipment / device which demand high reliability, kindly contact our sales window correspondents.

◆ RECOMMENDED PCB LAYOUT

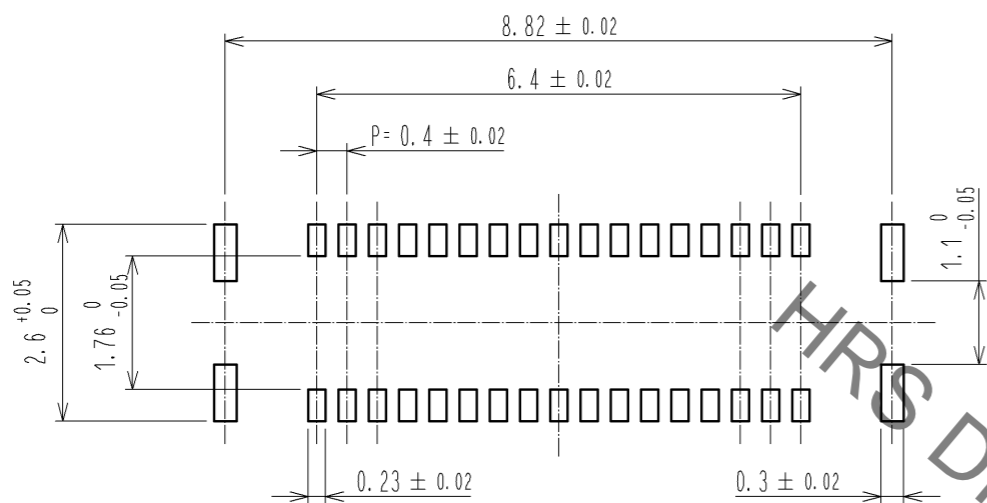

◆ RECOMMENDED METAL MASK DIMENSIONS

MATAL MASK THICKNESS : 100 μm

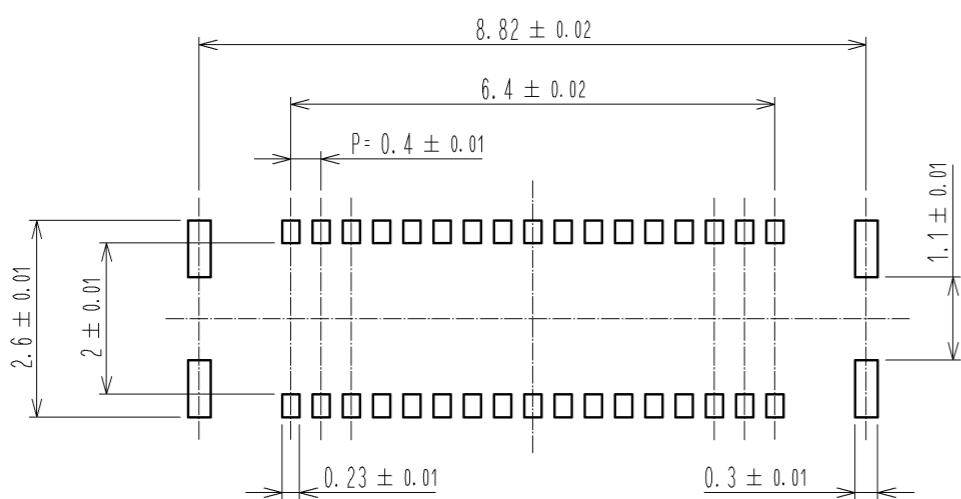

6 RECOMMENDED REFLOW TEMPERATURE PROFILE USING LEAD-FREE SOLDER PASTE.

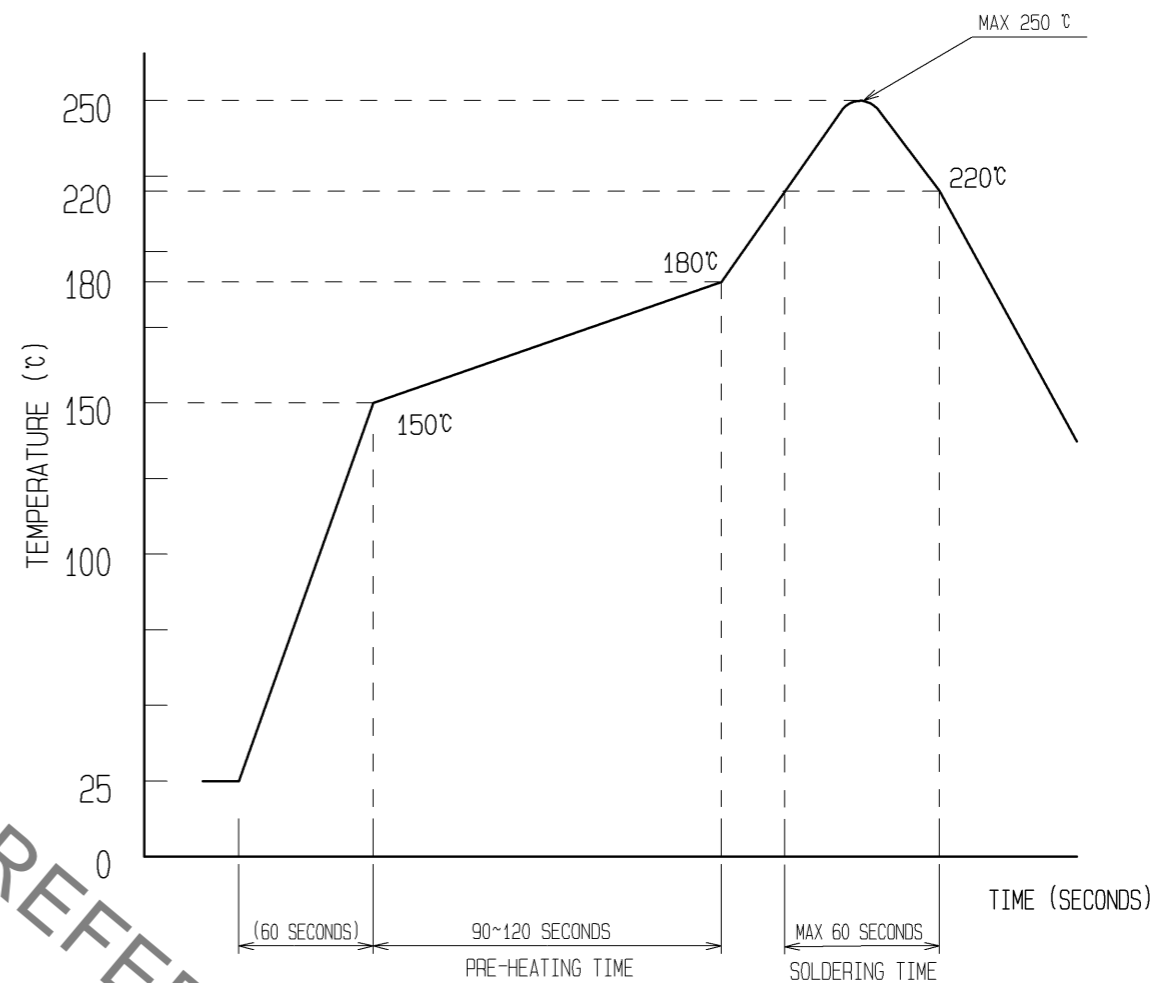

- REFLOW METHOD : IR REFLOW
 NUMBER OF REFLOW CYCLES : 2 CYCLES MAX.
- 1) REFLOW TIME
 DURATION ABOVE 220°C. 60 SEC MAX.
 (PEAK TEMPERATURE : 250°C MAX)
 - 2) PRE-HEAT TIME
 PRE-HEAT TEMPERATURE(MIN): 150°C
 PRE-HEAT TEMPERATURE(MAX): 180°C
 PRE-HEAT TIME: 90-120 SEC.

6 THE TEMPERATURE PROFILE IS PER THE CONDITIONS SHOWN ABOVE. ADDITIONAL FACTORS, SUCH AS SOLDER PASTE TYPE, PCB SIZE AND OTHER MOUNTED COMPONENTS COULD AFFECT THE PROFILE. THEREFORE, A THOROUGH EVALUATION OF MOUNTING CONDITION IS REQUIRED PRIOR TO PRODUCTION. TEMPERATURE IS MEASURED AT CONTACT LEAD.

HRS	DRAWING NO.	EDC3-343536-01
	PART NO.	BM20B(0.8)-34DS-0.4V(51)
	CODE NO.	CL684-9020-0-51

Sep.1.2019 Copyright 2019 HIROSE ELECTRIC CO., LTD. All Rights Reserved.
In case of consideration for using Automotive equipment / device which demand high reliability, kindly contact our sales window correspondents.

EMBOSED CARRIER TAPE PACKAGING (5:1)

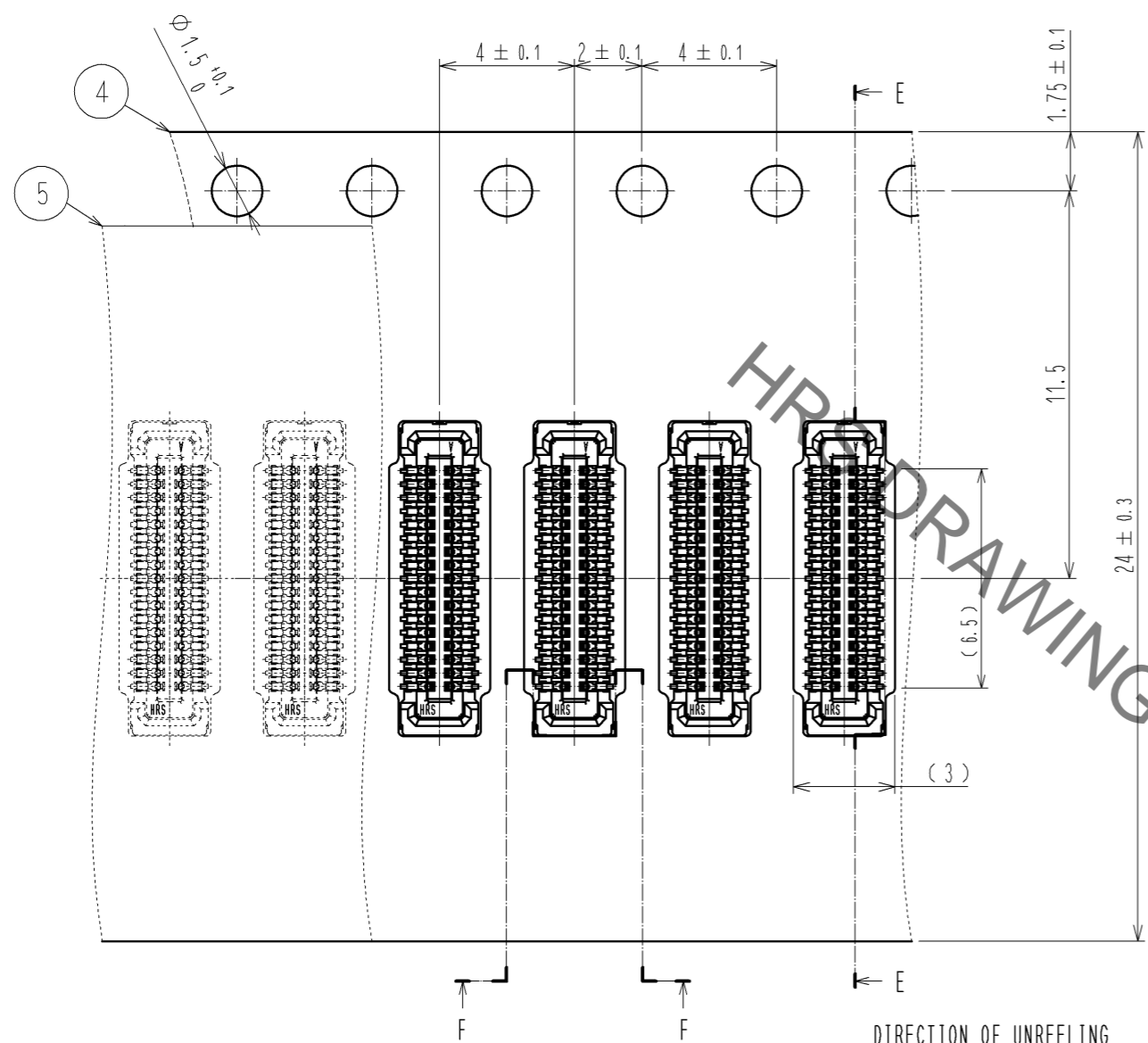

F-F (5:1)

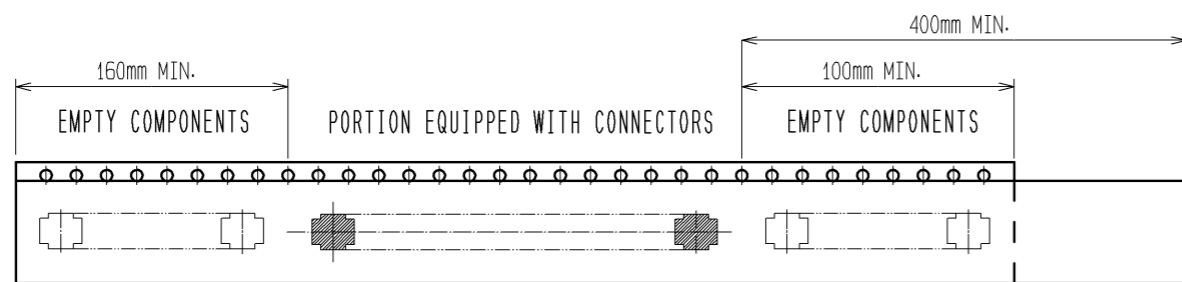
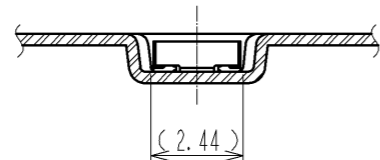

E-E (5:1)

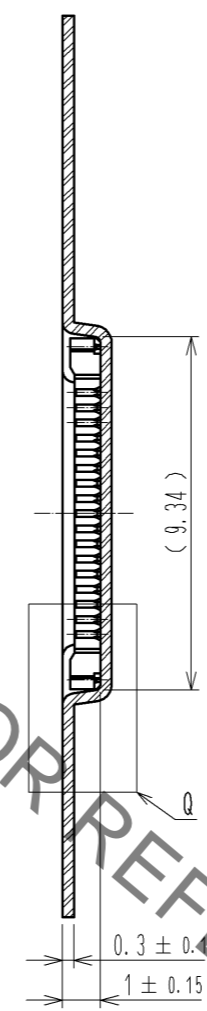

Q(10:1)

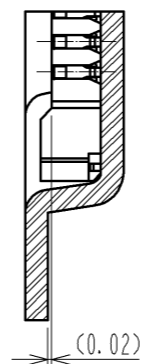

STYLE AND DIMENTION OF REEL (FREE)

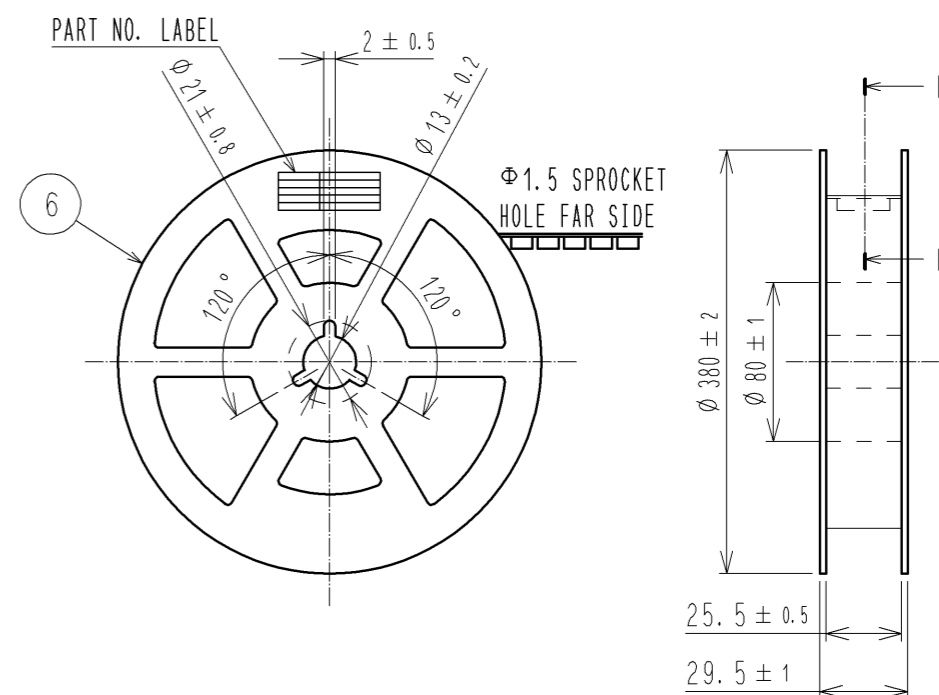

P-P (FREE)

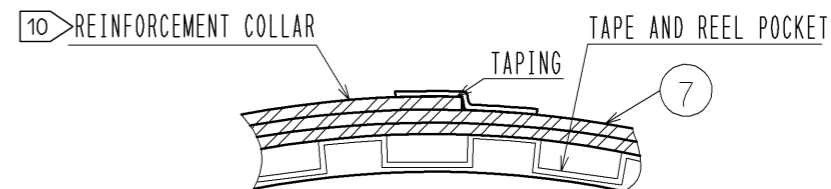

DETAIL OF PART NO. LABEL

製造年月日	** ** *
製品コード	CL0684-9020-0-(51)
製品名	BM20B(0.8)-34DS-0.4V(51)
数量	8,000
納入者	ヒロセ電機(株)

DATA OF MANUFACTURED
CODE NO.
PART NO.
QUANTITY
SUPPLIER

7. PER REEL 8000 CONNECTORS.

8. THE DIMENSIONS IN PARENTHESSES ARE FOR REFERENCE.

9 REFER TO JIS C 0806(PACKAGING OF COMPONENTS FOR AUTOMATIC HANDLING)

10 AFTER PACKAGING, ROLL 2 METERS OF THE REINFORCEMENT COLLAR TO OUTER CIRCUMFERENCE OF TAPE AND REEL POCKET. AND TAPE DOWN AT THE END THE COLLAR.

HRS

DRAWING NO.	EDC3-343536-01
PART NO.	BM20B(0.8)-34DS-0.4V(51)
CODE NO.	CL684-9020-0-51

\triangle 3/3

Looking for pricing, stock, or lifecycle information?

Click below to explore more details on WIN SOURCE:

- ⊖ [View BM20B\(0.8\)-34DS-0.4V\(51\) on WIN SOURCE](#)
- ⊖ [Hirose Electric Co Ltd Information](#)

Optimize Your Supply Chain with WIN SOURCE Solutions

- ✓ Global Sourcing Solution
- ✓ Obsolete Management
- ✓ Cost Control Management
- ✓ Shortage Management
- ✓ Alternative Solution
- ✓ Excess Inventory Management