



**THE DATASHEET OF
NLA5123MUR2G**



NLAS5123

SPDT, 1 Ω R_{ON} Switch

The NLAS5123 is a low R_{ON} SPDT analog switch. This device is designed for low operating voltage, high current switching of speaker output for cell phone applications. It can switch a balanced stereo output. The NLAS5123 can handle a balanced microphone/speaker/ringtone generator in a monophone mode. The device contains a break-before-make (BBM) feature.

Features

- Single Supply Operation:
1.65 V to 5.5 V V_{CC}
- Function Directly from LiON Battery
- R_{ON} Typical = 1.0 Ω @ $V_{CC} = 4.5$ V
- Low Static Power
- These are Pb-Free Devices

Typical Applications

- Cell Phone Speaker/Microphone Switching
- Ringtone-Chip/Amplifier Switching
- Stereo Balanced (Push-Pull) Switching

Important Information

- Continuous Current Rating Through each Switch ± 300 mA
- 1.2 x 1.0 x 0.4P mm 6-Lead Thin DFN Package



ON Semiconductor[®]

<http://onsemi.com>

MARKING DIAGRAMS

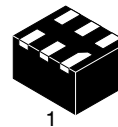

WDFN6
MN SUFFIX
CASE 506AS



W = Specific Device Code
M = Date Code
■ = Pb-Free Device

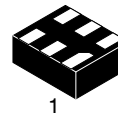

UDFN6
MU SUFFIX
CASE 517AA



X = Specific Device Code
M = Date Code
■ = Pb-Free Device

PIN ASSIGNMENTS

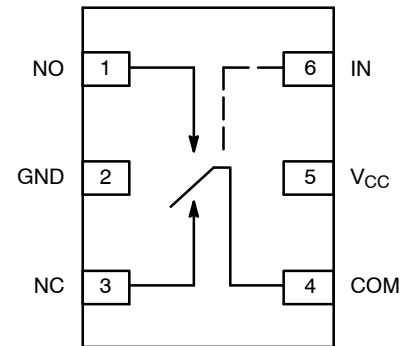

(Top View)

ORDERING INFORMATION

See detailed ordering and shipping information in the package dimensions section on page 8 of this data sheet.

NLAS5123

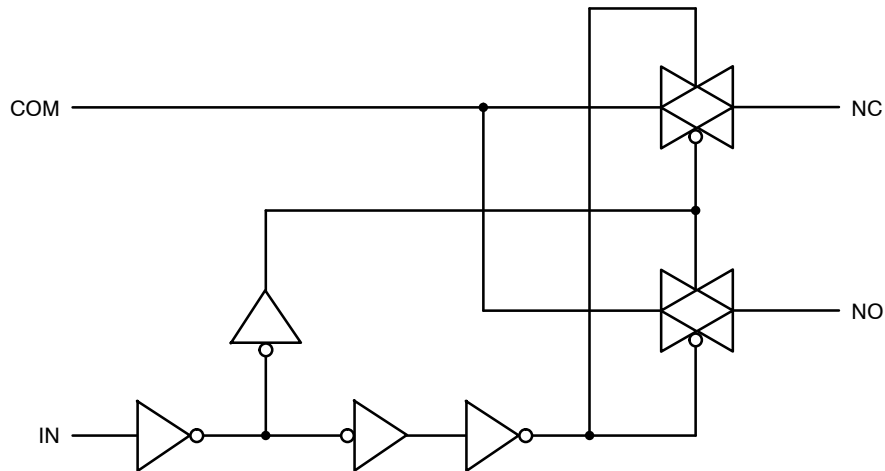

Figure 1. Input Equivalent Circuit

PIN DESCRIPTION

Pin Name	Description
NC, NO, COM	Data Ports
IN	Control Input

TRUTH TABLE

Control Input	Function
L	NC Connected to COM
H	NO Connected to COM

H = HIGH Logic Level.
L = LOW Logic Level.

MAXIMUM RATINGS

Symbol	Rating	Value	Unit
V_{CC}	Positive DC Supply Voltage	-0.5 to +6.0	V
V_{IS}	Analog Input Voltage (V_{NO} , V_{NC} , or V_{COM})	-0.5 to $V_{CC} + 0.5$	V
V_{IN}	Digital Select Input Voltage	-0.5 to +6.0	V
I_{an1}	Continuous DC Current from COM to NC/NO	± 300	mA
$I_{an1-pk1}$	Peak Current from COM to NC/NO, 10 Duty Cycles (Note 1)	± 500	mA
I_{clmp}	Continuous DC Current into COM/NC/NO with respect to V_{CC} or GND	± 100	mA

Stresses exceeding Maximum Ratings may damage the device. Maximum Ratings are stress ratings only. Functional operation above the Recommended Operating Conditions is not implied. Extended exposure to stresses above the Recommended Operating Conditions may affect device reliability.

1. Defined as 10% ON, 90% off duty cycle.

RECOMMENDED OPERATING CONDITIONS

Symbol	Rating	Min	Max	Unit
V_{CC}	Positive DC Supply Voltage	1.65	5.5	V
V_{IS}	Analog Input Voltage (NC, NO, COM)	0	V_{CC}	V
V_{IN}	Digital Select Input Voltage (IN)	0	V_{CC}	V
T_A	Operating Temperature Range	-40	85	$^{\circ}C$
t_r , t_f	Input Rise or Fall Time, SELECT		20 10	ns/V
			$V_{CC} = 3.0\text{ V}$ $V_{CC} = 5.5\text{ V}$	

NLAS5123

DC ELECTRICAL CHARACTERISTICS

Symbol	Parameter	Test Conditions	V _{CC} (V)	T _A = +25°C			T _A = -40°C to +85°C		Unit
				Min	Typ	Max	Min	Max	
V _{IH}	HIGH Level Input Voltage		2.7 4.5				2.0 2.4		V
V _{IL}	LOW Level Input Voltage		2.7 4.5					0.6 0.8	V
I _{IN}	Input Leakage Current	0 ≤ V _{IN} ≤ 5.5 V	0-5.5			±0.1		±1	μA
I _{OFF}	OFF State Leakage Current (Note 7)	0 ≤ NO, NC, COM ≤ V _{CC}	5.5	-2.0		+2.0		±20	nA
I _{ON}	ON State Leakage Current (Note 7)	0 ≤ NO, NC, COM ≤ V _{CC}	5.5	-4.0		+4.0		±40	nA
R _{ON}	Switch On Resistance (Note 2)	I _O = 100 mA, V _{IS} = 0 V to V _{CC}	2.7			1.7		2.0	Ω
		I _O = 100 mA, V _{IS} = 0 V to V _{CC}	4.5			1.0		1.2	
I _{CC}	Quiescent Supply Current All Channels ON or OFF	V _{IN} = V _{CC} or GND, I _{OUT} = 0	5.5			0.5		1.0	μA

Analog Signal Range

ΔR _{ON}	On Resistance Match Between Channels (Notes 2, 3, 4)	I _A = 100 mA, V _{IS} = 1.5 V	2.7		0.15			0.15	Ω
		I _A = 100 mA, V _{IS} = 2.5 V	4.5		0.12				
R _{flat}	On Resistance Flatness (Notes 2, 3, 5)	I _A = 100 mA, V _{IS} = 0 V to V _{CC}	2.7		0.4			0.4	Ω
		I _A = 100 mA, V _{IS} = 0 V to V _{CC}	4.5		0.3				

2. Measured by the voltage drop between NC/NO and COM pins at the indicated current through the switch. On Resistance is determined by the lower of the voltages on the two (NO, NC, COM).
3. Parameter is characterized but not tested in production.
4. ΔR_{ON} = R_{ON} max – R_{ON} min measured at identical V_{CC}, temperature and voltage levels.
5. Flatness is defined as the difference between the maximum and minimum value of On Resistance over the specified range of conditions.
6. Guaranteed by Design.
7. This parameter is guaranteed by design but not tested. The bus switch contributes no propagation delay other than the RC delay of the On Resistance of the switch and the 50 pF load capacitance, when driven by an ideal voltage source (zero output impedance).

NLAS5123

AC ELECTRICAL CHARACTERISTICS

Symbol	Parameter	Test Conditions	V _{CC} (V)	T _A = +25°C			T _A = -40°C to +85°C		Unit	Figure #
				Min	Typ	Max	Min	Max		
t _{PHL} t _{PLH}	Propagation Delay Bus-to-Bus (Note 9)	V _{IN} = V _{IH} or V _{IL}	2.7 4.5			2.0 0.3			ns	
t _{ON}	Output Enable Time Turn On Time (COM to NO or NC)	V _{IS} = 1.5 V, R _L = 50 Ω, C _L = 35 pF V _{IS} = 3.0 V, R _L = 50 Ω, C _L = 35 pF	2.7 4.5			30 20		35 25	ns	3, 4
t _{OFF}	Output Disable Time Turn Off Time (COM to NO, NC)	V _{IS} = 1.5V, R _L = 50 Ω, C _L = 35 pF V _{IS} = 3.0 V, R _L = 50 Ω, C _L = 35 pF	2.7 4.5			20 15		25 20	ns	3, 4
t _{BBM}	Break Before Make Time (Note 8)	V _{IS} = 1.5V, R _L = 50 Ω, C _L = 35 pF	2.7 4.5	0.5 0.5			0.5 0.5		ns	2
Q	Charge Injection (Note 8)	C _L = 1.0 nF, V _{GEN} = 0 V R _{GEN} = 0 Ω	2.7 4.5		26 48				pC	6
O _{IRR}	Off Isolation (Note 10)	R _L = 50 Ω f = 1.0 MHz	2.7 – 5.5		-62				dB	5
X _{talk}	Crosstalk	R _L = 50 Ω f = 1.0 MHz	2.7 – 5.5		-70				dB	7
BW	-3 dB Bandwidth	R _L = 50 Ω	2.7 – 5.5		55				MHz	8
THD	Total Harmonic Distortion (Note 8)	R _L = 600 Ω 0.5 V _{P-P} f = 20 Hz to 20 kHz	2.7 – 5.5		0.012				%	9

8. Guaranteed by Design.

9. This parameter is guaranteed by design but not tested. The bus switch contributes no propagation delay other than the RC delay of the On Resistance of the switch and the 50 pF load capacitance, when driven by an ideal voltage source (zero output impedance).

10. Off Isolation = 20 log₁₀ [V_{COM}/V_{NO,NC}].

CAPACITANCE (Note 11)

Symbol	Parameter	Test Conditions	Typ	Max	Unit
C _{IN}	Select Pin Input Capacitance	V _{CC} = 0 V, f = 1 MHz	2.0		pF
C _{NC/NO}	NC, NO Port Off Capacitance	V _{CC} = 4.5 V, f = 1 MHz	20		pF
C _{COM}	COM Port Capacitance when Switch is Enabled	V _{CC} = 4.5 V, f = 1 MHz	55		pF

11. T_A = +25°C, f = 1 MHz, Capacitance is characterized but not tested in production.

NLAS5123

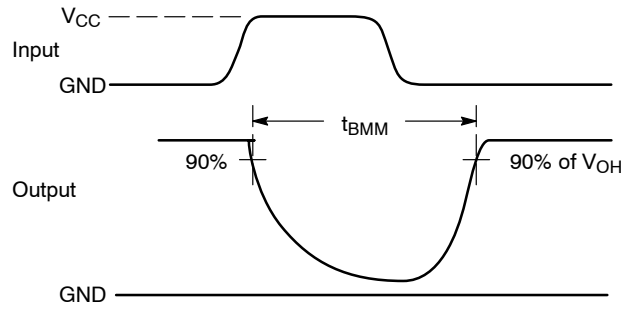
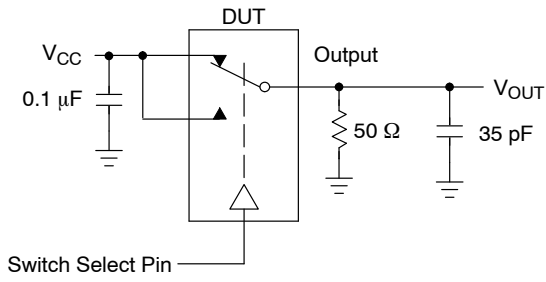

Figure 2. t_{BMM} (Time Break-Before-Make)

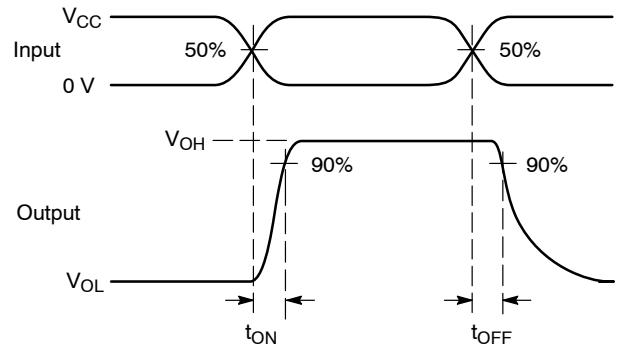
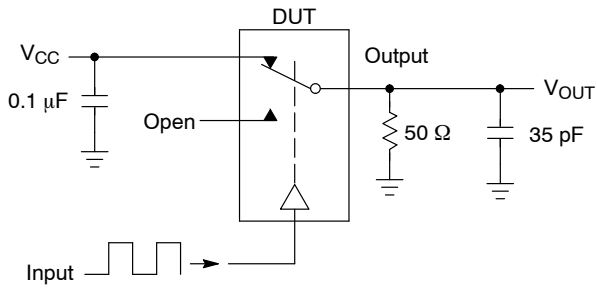

Figure 3. t_{ON}/t_{OFF}

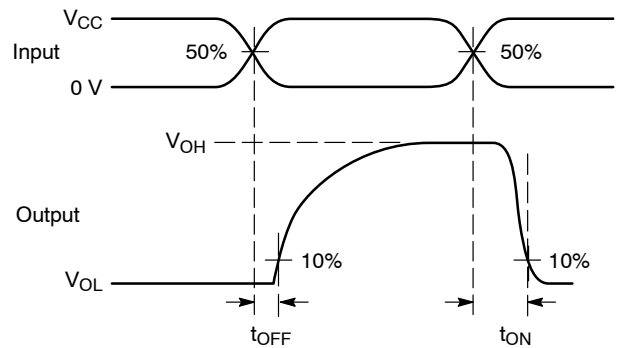
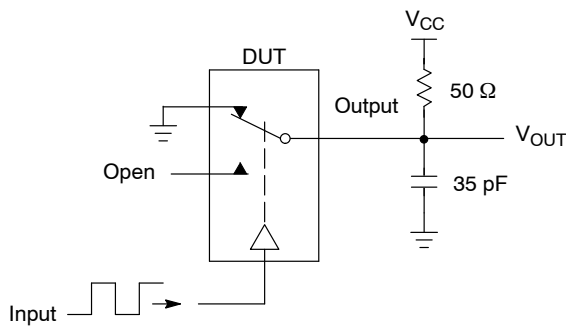
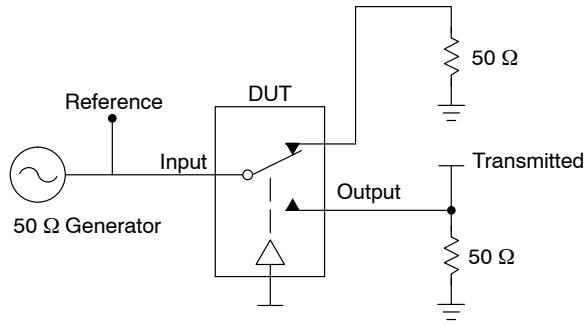

Figure 4. t_{ON}/t_{OFF}

NLAS5123



Channel switch control/s test socket is normalized. Off isolation is measured across an off channel. On loss is the bandwidth of an On switch. V_{ISO} , Bandwidth and V_{ONL} are independent of the input signal direction.

$$V_{ISO} = \text{Off Channel Isolation} = 20 \text{ Log} \left(\frac{V_{OUT}}{V_{IN}} \right) \text{ for } V_{IN} \text{ at } 100 \text{ kHz}$$

$$V_{ONL} = \text{On Channel Loss} = 20 \text{ Log} \left(\frac{V_{OUT}}{V_{IN}} \right) \text{ for } V_{IN} \text{ at } 100 \text{ kHz to } 50 \text{ MHz}$$

Bandwidth (BW) = the frequency 3 dB below V_{ONL}

V_{CT} = Use V_{ISO} setup and test to all other switch analog input/outputs terminated with 50 Ω

Figure 5. Off Channel Isolation/On Channel Loss (BW)/Crosstalk (On Channel to Off Channel)/ V_{ONL}

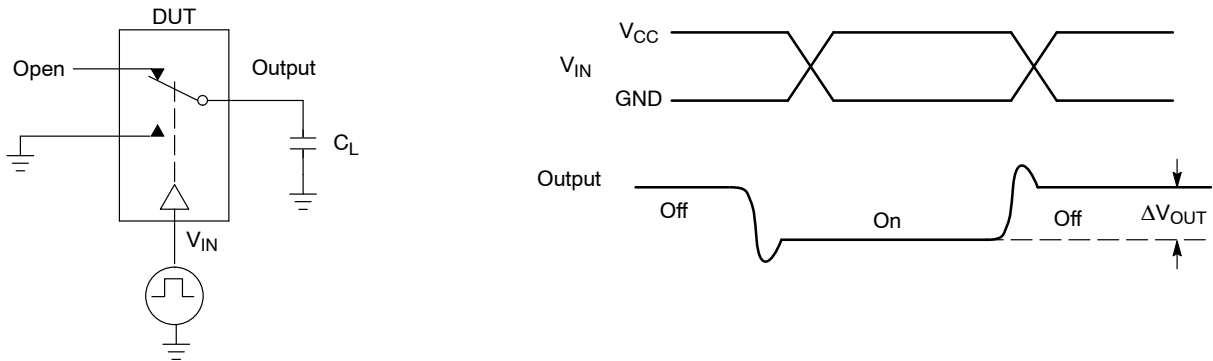

Figure 6. Charge Injection: (Q)

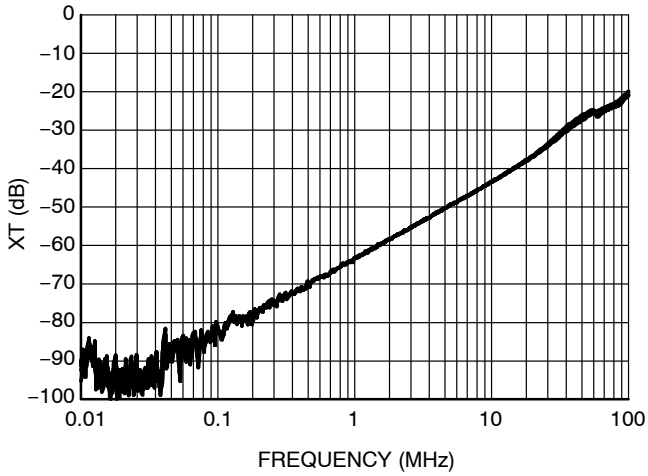

Figure 7. Cross Talk vs. Frequency
@ $V_{CC} = 4.5\text{ V}$

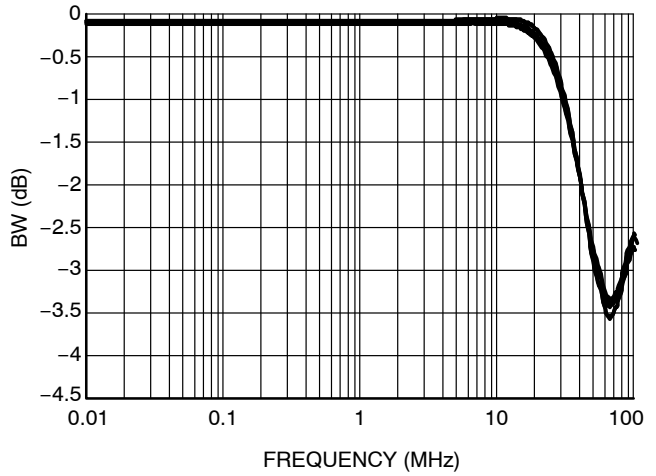

Figure 8. Bandwidth vs. Frequency

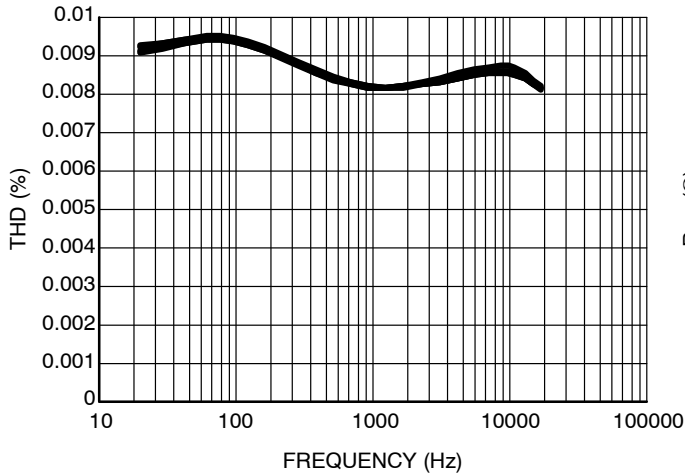

Figure 9. Total Harmonic Distortion

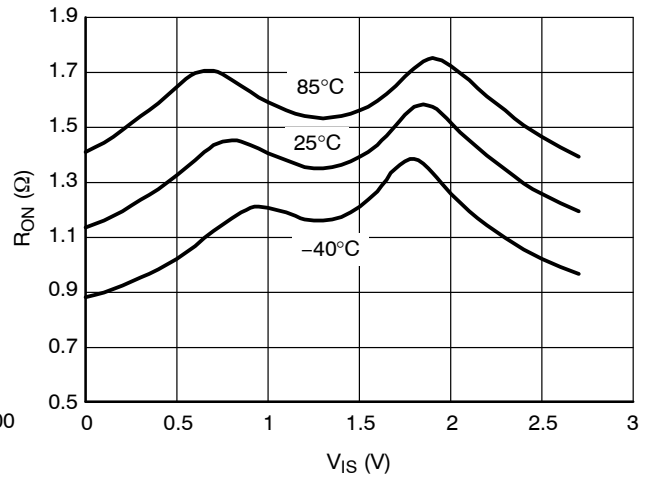

Figure 10. On-Resistance vs. Input Voltage
@ $V_{CC} = 2.7\text{ V}$

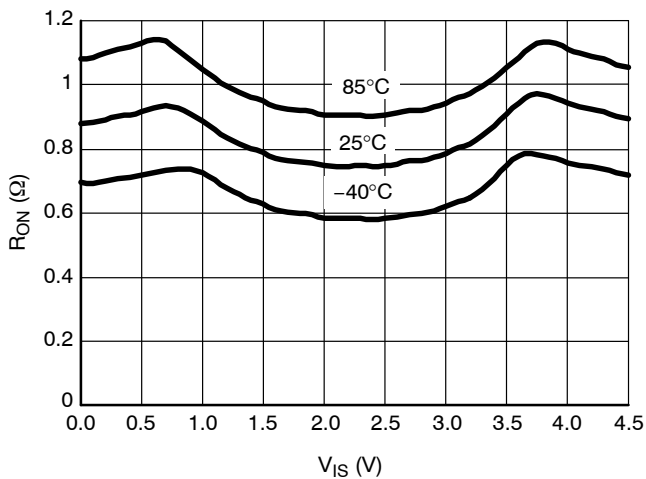

Figure 11. On-Resistance vs. Input Voltage
@ $V_{CC} = 4.5\text{ V}$

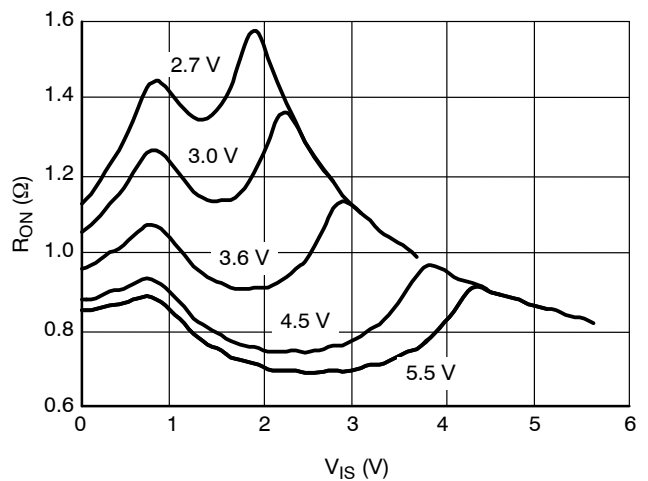

Figure 12. On-Resistance vs. Input Voltage

NLAS5123

DEVICE ORDERING INFORMATION

Device Order Number	Device Nomenclature					Package Type	Tape & Reel Size [†]
	Circuit Indicator	Technology	Device Function	Package Suffix	Tape & Reel Suffix		
NLAS5123MNR2G	NL	AS	5123	MN	2	WDFN6 (Pb-Free)	3000 / Tape & Reel
NLAS5123MUR2G	NL	AS	5123	MU	2	UDFN6 (Pb-Free)	3000 / Tape & Reel

[†]For information on tape and reel specifications, including part orientation and tape sizes, please refer to our Tape and Reel Packaging Specifications Brochure, BRD8011/D.

NLAS5123

PACKAGE DIMENSIONS

UDFN6, 1.2x1.0, 0.4P
CASE 517AA-01
ISSUE C

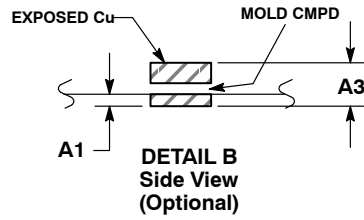
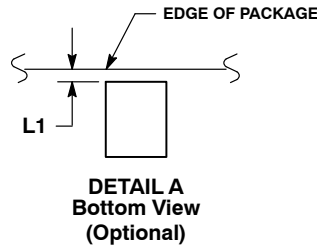
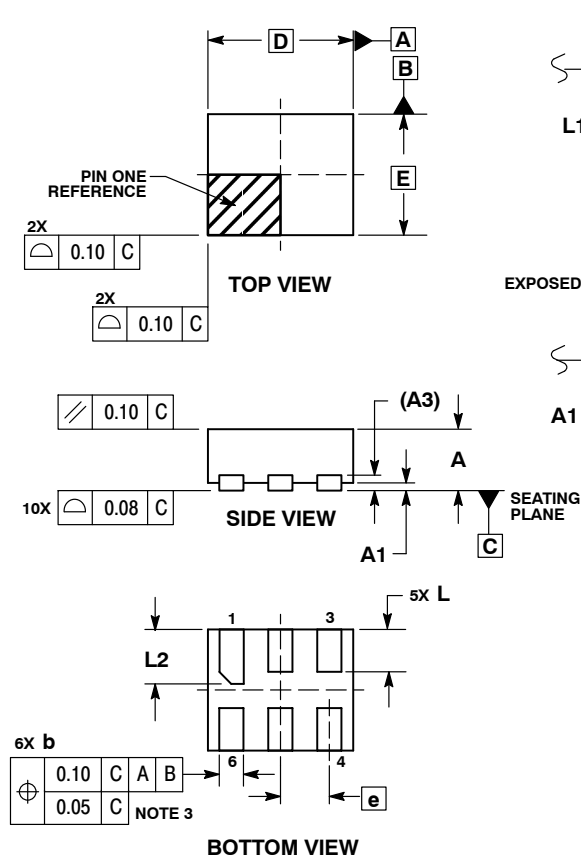

- NOTES:
1. DIMENSIONING AND TOLERANCING PER ASME Y14.5M, 1994.
 2. CONTROLLING DIMENSION: MILLIMETERS.
 3. DIMENSION b APPLIES TO PLATED TERMINAL AND IS MEASURED BETWEEN 0.25 AND 0.30 mm FROM TERMINAL.
 4. COPLANARITY APPLIES TO THE EXPOSED PAD AS WELL AS THE TERMINALS.

DIM	MILLIMETERS	
	MIN	MAX
A	0.45	0.55
A1	0.00	0.05
A3	0.127	REF
b	0.15	0.25
D	1.20	BSC
E	1.00	BSC
e	0.40	BSC
L	0.30	0.40
L1	0.00	0.15
L2	0.40	0.50

MOUNTING FOOTPRINT*

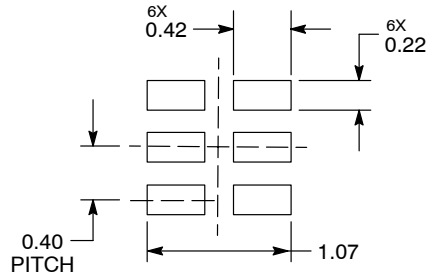

DIMENSIONS: MILLIMETERS

*For additional information on our Pb-Free strategy and soldering details, please download the ON Semiconductor Soldering and Mounting Techniques Reference Manual, SOLDERRM/D.

NLAS5123

PACKAGE DIMENSIONS

WDFN6 1.2x1.0, 0.4P
CASE 506AS-01
ISSUE C

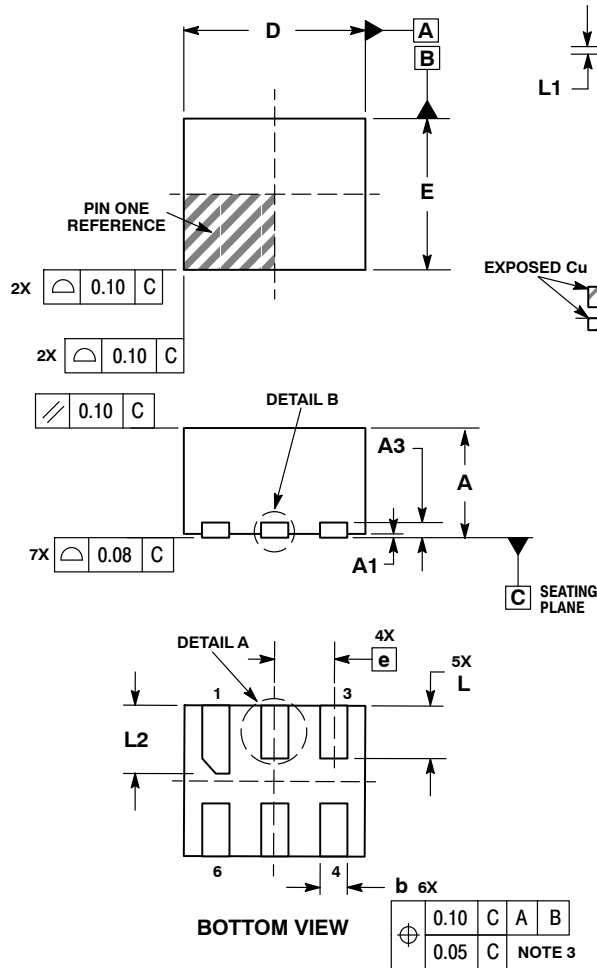

NOTES:

1. DIMENSIONING AND TOLERANCING PER ASME Y14.5M, 1994.
2. CONTROLLING DIMENSION: MILLIMETERS.
3. DIMENSION b APPLIES TO PLATED TERMINAL AND IS MEASURED BETWEEN 0.25 AND 0.30mm FROM TERMINAL.
4. COPLANARITY APPLIES TO THE EXPOSED PAD AS WELL AS THE TERMINALS.

DIM	MILLIMETERS	
	MIN	MAX
A	0.70	0.80
A1	0.00	0.05
A3	0.20 REF	
b	0.15	0.25
D	1.20 BSC	
E	1.00 BSC	
e	0.40 BSC	
L	0.30	0.40
L1	0.00	0.15
L2	0.40	0.50

MOUNTING FOOTPRINT*

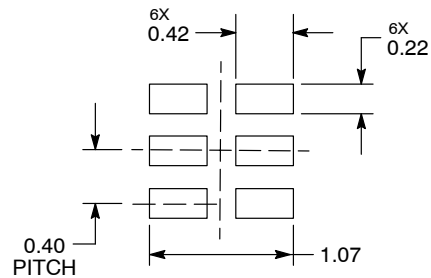

DIMENSIONS: MILLIMETERS

*For additional information on our Pb-Free strategy and soldering details, please download the ON Semiconductor Soldering and Mounting Techniques Reference Manual, SOLDERRM/D.

ON Semiconductor and are registered trademarks of Semiconductor Components Industries, LLC (SCILLC). SCILLC reserves the right to make changes without further notice to any products herein. SCILLC makes no warranty, representation or guarantee regarding the suitability of its products for any particular purpose, nor does SCILLC assume any liability arising out of the application or use of any product or circuit, and specifically disclaims any and all liability, including without limitation special, consequential or incidental damages. "Typical" parameters which may be provided in SCILLC data sheets and/or specifications can and do vary in different applications and actual performance may vary over time. All operating parameters, including "Typicals" must be validated for each customer application by customer's technical experts. SCILLC does not convey any license under its patent rights nor the rights of others. SCILLC products are not designed, intended, or authorized for use as components in systems intended for surgical implant into the body, or other applications intended to support or sustain life, or for any other application in which the failure of the SCILLC product could create a situation where personal injury or death may occur. Should Buyer purchase or use SCILLC products for any such unintended or unauthorized application, Buyer shall indemnify and hold SCILLC and its officers, employees, subsidiaries, affiliates, and distributors harmless against all claims, costs, damages, and expenses, and reasonable attorney fees arising out of, directly or indirectly, any claim of personal injury or death associated with such unintended or unauthorized use, even if such claim alleges that SCILLC was negligent regarding the design or manufacture of the part. SCILLC is an Equal Opportunity/Affirmative Action Employer. This literature is subject to all applicable copyright laws and is not for resale in any manner.

PUBLICATION ORDERING INFORMATION

LITERATURE FULFILLMENT:
Literature Distribution Center for ON Semiconductor
P.O. Box 5163, Denver, Colorado 80217 USA
Phone: 303-675-2175 or 800-344-3860 Toll Free USA/Canada
Fax: 303-675-2176 or 800-344-3867 Toll Free USA/Canada
Email: orderlit@onsemi.com

N. American Technical Support: 800-282-9855 Toll Free USA/Canada
Europe, Middle East and Africa Technical Support: Phone: 421 33 790 2910
Japan Customer Focus Center Phone: 81-3-5773-3850

ON Semiconductor Website: www.onsemi.com
Order Literature: <http://www.onsemi.com/orderlit>
For additional information, please contact your local Sales Representative

Looking for pricing, stock, or lifecycle information?

Click below to explore more details on WIN SOURCE:

 [View NLAS5123MUR2G on WIN SOURCE](#)

 [ON Semiconductor](#) Information

Optimize Your Supply Chain with WIN SOURCE Solutions

-  Global Sourcing Solution
-  Obsolete Management
-  Cost Control Management
-  Shortage Management
-  Alternative Solution
-  Excess Inventory Management