

## PWM/PFM Step-Down Combination Regulator/Controller

### Features

- Internal Switching Transistor Supports 600mA Output Current
- External Switching Transistor Control for Output Currents of 2A+
- 300kHz Oscillator Frequency Supports Small Inductor Size
- Short Circuit Protection
- Built-In Undervoltage Lockout
- 95% Typical Efficiency
- Automatic Switchover to Current-Saving PFM Mode at Low Output Loads
- Automatic Output Capacitor Discharge While in Shutdown
- Programmable Soft-Start
- Power-Saving Shutdown Mode
- Small 8-Pin SOP Package

### Applications

- Portable Test Equipment
- Local Logic Supplies
- Portable Audio Systems
- Portable Scanners
- Palmtops
- Electronic Organizers

### Device Selection Table

Part Number	Output Voltage (V)	Package	Operating Temp. Range
TC120503EHA	5.0	8-Pin SOP	-40°C to +85°C
TC120333EHA	3.3	8-Pin SOP	-40°C to +85°C
TC120303EHA	3.0	8-Pin SOP	-40°C to +85°C

### Package Type

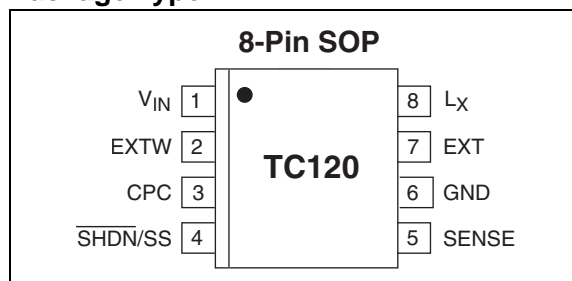

### General Description

TC120 is a 300kHz PFM/PWM step-down (Buck) DC/DC regulator/controller combination for use in systems operating from two or more cells, or in line-powered applications. It uses PWM as the primary modulation scheme, but automatically converts to PFM at low output loads for greater efficiency. It requires only an external inductor, Schottky diode, and two capacitors to implement a step-down converter having a maximum output current of 600mA ( $V_{IN} = 5V$ ,  $V_{OUT} = 3.3V$ ). An external switching transistor (P-channel MOSFET) can be added to increase output current capability to support output loads of 2A or more.

The TC120 consumes only 55 $\mu$ A (max) of supply current ( $V_{OUT} = 3.3V$ ) and can be placed in shutdown mode by bringing the shutdown input (SHDN) low. During shutdown, the regulator is disabled, supply current is reduced to 2.5 $\mu$ A (max), and  $V_{OUT}$  is internally pulled to ground, discharging the output capacitor. Normal operation resumes when SHDN is brought high. Other features include a built-in undervoltage lockout (UVLO), an externally programmable soft start time, and output short circuit protection. The TC120 operates from a maximum input voltage of 10V and is available in a low-profile 8-Pin SOP package.

### Functional Block Diagram

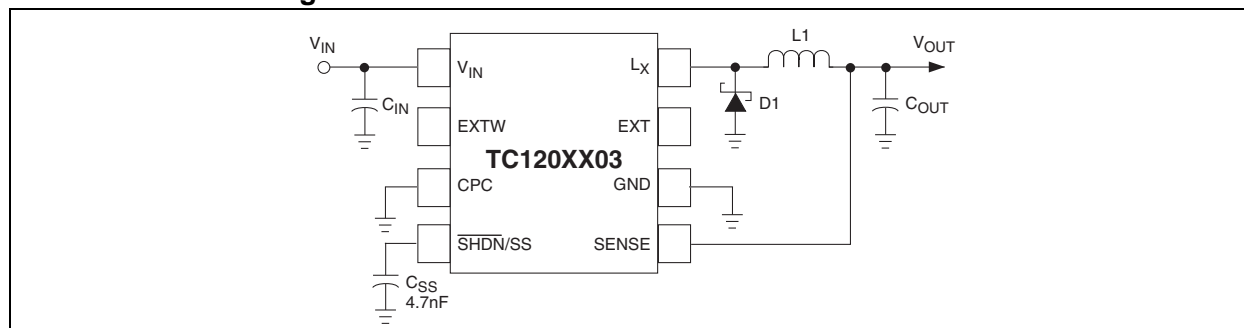

# TC120

## 1.0 ELECTRICAL CHARACTERISTICS

### Absolute Maximum Ratings\*

Power Supply Voltage ( $V_{IN}$ ).....	-0.3V to +12V
Voltage on $V_{OUT}$ Pin .....	-0.3V to +12V
Voltage on LX, Boost Pins .....	( $V_{IN} - 12V$ ) to ( $V_{IN} + 0.3V$ )
Voltage on EXT1, EXT2, $\overline{SHDN}$ Pins .....	(-0.3V) to ( $V_{IN} + 0.3V$ )
$L_X$ Pin Current .....	700mA pk
EXT1, EXT2 Pin Current .....	$\pm 50mA$
Continuous Power Dissipation .....	300mW
Operating Temperature Range.....	-40°C to +85°C
Storage Temperature Range .....	-40°C to +150°C

\*Stresses above those listed under "Absolute Maximum Ratings" may cause permanent damage to the device. These are stress ratings only and functional operation of the device at these or any other conditions above those indicated in the operation sections of the specifications is not implied. Exposure to Absolute Maximum Rating conditions for extended periods may affect device reliability.

### TC120 ELECTRICAL SPECIFICATIONS

Electrical Characteristics: Test circuit of Figure 3-1, $T_A = 25^\circ C$ , $V_{IN} = V_R \times 1.2$ , Note 1 unless otherwise noted.						
Symbol	Parameter	Min	Typ	Max	Units	Test Conditions
$V_{OUT}$	Output Voltage	$V_R \times 0.975$	$V_R \pm 0.5\%$	$V_R \times 1.025$	V	$V_{OUT} = 3.0V$ $I_{OUT} = 120mA$ (Note 1) $V_{OUT} = 3.3V$ $I_{OUT} = 132mA$ $V_{OUT} = 5.0V$ $I_{OUT} = 200mA$
$V_{IN}$	Input Voltage	1.8	—	10.0	V	
$I_{OUTMAX}$	Maximum Output Current	500 600 600	— — —	— — —	mA	$V_{OUT} = 3.0V$ $V_{OUT} = 3.3V$ $V_{OUT} = 5.0V$
$I_{IN}$	Supply Current	—	52 55 71	82 86 110	$\mu A$	$V_{OUT} = 3.0V$ $V_{IN} = V_R \times 1.05$ , no load $V_{OUT} = 3.3V$ $V_{OUT} = 5.0V$
$I_{SHDN}$	Shutdown Supply Current	—	1.5	2.5	$\mu A$	No load, $\overline{SHDN} = 0V$ , (Note 2)
$I_{LX}$	LX Pin Leakage Current	— —	— 1.5	2 2.5	$\mu A$	Measured at EXT1 Pin (Note 2) No load, $\overline{SHDN} = 0V$
$R_{DSON(LX)}$	LX Pin ON Resistance	— — —	0.69 0.64 0.44	0.94 0.85 0.58	$\Omega$	$V_{OUT} = 3.0V$ $V_{OUT} = V_R \times 0.9$ (Note 2) $V_{OUT} = 3.3V$ $V_{LX} = V_{IN} - 0.2V$ , 10 $\Omega$ $V_{OUT} = 5.0V$ Resistor from $L_X$ to $V_{IN}$ , $\overline{SHDN} = V_{IN}$
$R_{EXTH}$	EXT1, EXT2 On Resistance to $V_{IN}$	— — —	38 35 24	52 47 32	$\Omega$	$V_{OUT} = 3.0V$ $\overline{SHDN} = V_{IH}$ ; EXT1 and EXT2 $V_{OUT} = 3.3V$ connected to 200 $\Omega$ load, $V_{OUT} = 5.0V$ $V_{EXT1} = V_{EXT2} = (V_{IN} - 0.4V)$ ; $V_{OUT} = V_{IN}$ (Note 2)
$R_{EXTL}$	EXT1, EXT2 On Resistance to GND	— — —	31 29 20	41 37 26	$\Omega$	$V_{OUT} = 3.0V$ $\overline{SHDN} = V_{IH}$ ; EXT1 and EXT2 $V_{OUT} = 3.3V$ pulled up through a series $V_{OUT} = 5.0V$ resistance of 200 $\Omega$ to a voltage such that $V_{EXT1, 2} = 0.4V$
$f_{OSC}$	Oscillator Frequency	255	300	345	kHz	Measured at EXT1 Pin, $V_{IN} = V_{OUT} + 0.3V$ , $I_{OUT} = 20mA$ (Note 3)
DPWM	Maximum PWM Duty Cycle	—	—	100	%	
DPFM	PFM Duty Cycle	15	25	35	%	No load
$\eta$	Efficiency	—	95	—	%	$V_{IN} > V_R \times 1.2$

- Note**
- 1:  $V_R$  is the factory-programmed output voltage setting.
  - 2: No external components connected, except  $C_{SS}$ .
  - 3: While operating in PWM Mode.

Electrical Characteristics: Test circuit of Figure 3-1, $T_A = 25^\circ\text{C}$ , $V_{IN} = V_R \times 1.2$ , Note 1 unless otherwise noted.						
Symbol	Parameter	Min	Typ	Max	Units	Test Conditions
$V_{UVLO}$	Minimum Operating Voltage	0.9	—	1.8	V	$V_{OUT} = V_R \times 0.9$ (Note 2), $\overline{\text{SHDN}} = V_{IN}$ Measured with internal transistor in OFF state and $V_{IN}$ falling
$V_{IH}$	$\overline{\text{SHDN}}$ Input Logic High, Threshold Voltage	0.65	—	—	V	$V_{OUT} = 0\text{V}$ , (Note 2)
$V_{IL}$	$\overline{\text{SHDN}}$ Input Logic Low, Threshold Voltage	—	—	0.20	V	$V_{OUT} = 0\text{V}$ , (Note 2)
$t_{PRO}$	Short Circuit Protection Response Time	3	5	8	msec	Time from $V_{OUT} = 0\text{V}$ to $\overline{\text{SHDN}} = V_{IL}$ (Note 2)
$t_{SS}$	Soft Start Time	6	10	16	msec	

- Note**
- 1:  $V_R$  is the factory-programmed output voltage setting.
  - 2: No external components connected, except  $C_{SS}$ .
  - 3: While operating in PWM Mode.

# TC120

## 2.0 PIN DESCRIPTIONS

The descriptions of the pins are listed in Table 2-1.

**TABLE 2-1: PIN FUNCTION TABLE**

Pin No. (8-Pin SOP)	Symbol	Description
1	V <sub>IN</sub>	Unregulated supply input.
2	EXTW	Extended external switching transistor drive output. This output follows the timing on the EXT output with an additional 100nsec blanking time on both the leading and trailing edges. That is, this output transitions from high-to-low 100 nsec prior to the same transition on EXT; and transitions low-to-high 100nsec after the same transition on EXT; resulting in a longer external switch ON time. (See <i>Section 3.9 External Switching Transistor Selection</i> ).
3	CPC	Charge pump capacitor input. An inverting charge pump is formed by attaching a capacitor and diode to this input. (See <i>Section 3.5 Improving High Load Efficiency In Regulator Operating Mode</i> ).
4	SHDN/SS	Shutdown and soft-start control input. A soft start capacitor of 100pF (min) must be connected to this input. The soft start capacitor is charged by an internal $\mu$ A current source that gently ramps the TC120 into service. Shutdown control is best implemented with an external open collector (or open drain) switch. The TC120 enters shutdown when this input is low. During shutdown, the regulator is disabled, and supply current is reduced to less than 2.5 $\mu$ A. Normal operation is restored when this input is open-circuited, and allowed to float high. (See <i>Section 3.6 Low Power Shutdown Mode/Soft Start Input</i> ).
5	SENSE	Voltage sense input. This input must be connected to the output voltage node at the physical location that requires the tightest voltage regulation.
6	GND	Ground terminal.
7	EXT	External switching transistor drive output. This output connects directly to the gate of an external P-channel MOSFET for applications requiring output currents greater than 600mA. The timing of this output exactly matches that of the gate drive for the internal P-channel transistor. This output can drive a maximum capacitance of 1000pF. (See <i>Section 3.9 External Switching Transistor Selection</i> ).
8	Lx	Inductor terminal. This pin is connected to the drain of the internal P-channel switching transistor. If the TC120 is operated as a regulator (i.e., using the internal switch); the inductor must be connected between this pin and the SENSE pin.

## 3.0 DETAILED DESCRIPTION

The TC120 can be operated as an integrated step-down regulator (using the internal switching transistor); or as a step-down regulator controller (using an external switching transistor). When operating as an integrated regulator, the only required external components are a Schottky diode, inductor and an output capacitor. Operating in this configuration, the TC120 is capable of supporting output load currents to a maximum of 600mA with operating efficiencies above 85%. Efficiencies at high loads can be further improved by using the on-board charge pump circuit to pull the gate of the internal switching transistor below ground for the lowest possible ON resistance. (For more information, see *Section 3.5 Improving High Load Efficiency in Regulator Operating Mode*).

Higher output currents are achieved by operating the TC120 with an external P-channel switching transistor (controller mode). In this operating configuration, the maximum output current is determined primarily by the ON resistance of the P-channel switch and the series resistance of the inductor.

**FIGURE 3-1: TEST CIRCUIT**

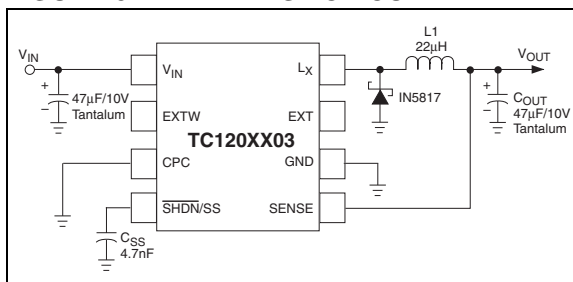

### 3.1 Inductor Selection

Selecting the proper inductor value is a trade-off between physical size and power conversion requirements. Lower value inductors cost less, but result in higher ripple current and core losses. They are also more prone to saturate since the coil current ramps faster and could overshoot the desired peak value. This not only reduces efficiency, but could also cause the current rating of the external components to be exceeded. Larger inductor values reduce both ripple current and core losses, but are larger in physical size and tend to increase the start-up time slightly. A 22µH inductor is the best overall compromise and is recommended for use with the TC120. For highest efficiency, use inductors with a low DC resistance (less than 20mΩ). To minimize radiated noise, consider using a toroid, pot core or shielded-bobbin inductor.

### 3.2 Input Bypass Capacitor

Using an input bypass capacitor reduces peak current transients drawn from the input supply, and reduces the switching noise generated by the regulator. The source impedance of the input supply determines the size of the capacitor that should be used.

### 3.3 Output Capacitor

The effective series resistance of the output capacitor directly affects the amplitude of the output voltage ripple. (The product of the peak inductor current and the ESR determines output ripple amplitude.) Therefore, a capacitor with the lowest possible ESR should be selected. Smaller capacitors are acceptable for light loads or in applications where ripple is not a concern. A 47µF Tantalum capacitor is recommended for most applications. The Sprague 595D series of tantalum capacitors are amongst the smallest of all low ESR surface mount capacitors available. Table 3-1 lists suggested components and suppliers.

### 3.4 Catch Diode

The high operating frequency of the TC120 requires a high-speed diode. Schottky diodes such as the MA737 or 1N5817 through 1N5823 (and the equivalent surface mount versions) are recommended. Select a diode whose average current rating is greater than the peak inductor current; and whose voltage rating is higher than  $V_{INMAX}$ .

### 3.5 Improving High Load Efficiency in Regulator Operating Mode

If the TC120 is operated at high output loads most (or all) of the time, efficiency can be improved with the addition of two components. Ordinarily, the voltage swing on the gate of the internal P-channel transistor is from ground to  $V_{IN}$ . By adding a capacitor and diode as shown in Figure 3-2, an inverting charge pump is formed, enabling the internal gate voltage to swing from a negative voltage to  $+V_{IN}$ . This increased drive lowers the  $R_{DS(ON)}$  of the internal transistor, improving efficiency at high output currents. Care must be taken to ensure the voltage measured between  $V_{IN}$  and CPC does not exceed an absolute value of 10V. While this is not a problem at values of  $V_{IN}$  at (or below) 5V, higher  $V_{IN}$  values will require the addition of a clamping mechanism (such as a Zener diode) to limit the voltage as described. While this technique improves efficiency at high output loads, it is at the expense of low load efficiency because energy is expended charging and discharging the charge pump capacitor. This technique is therefore not recommended for applications that operate the TC120 at low output currents for extended time periods. If unused, CPC must be grounded.

## 3.6 Low Power Shutdown Mode/Soft Start Input

The  $\overline{\text{SHDN/SS}}$  input acts as both the shutdown control and the node for the external soft start capacitor, which is charged by an internal  $1\mu\text{A}$  current source. A value of  $4700\text{pF}$  ( $100\text{pF}$  minimum) is recommended for the soft start capacitor. Failure to do this may cause large overshoot voltages and/or large inrush currents resulting in possible instability. The TC120 enters a low power shutdown mode when  $\overline{\text{SHDN/SS}}$  is brought low. While in shutdown, the oscillator is disabled and the output discharge switch is turned on, discharging the output capacitor. Figure 3-3 shows the recommended interface circuits to the  $\overline{\text{SHDN/SS}}$  input. As shown, the  $\overline{\text{SHDN/SS}}$  input should be controlled using an open collector (or open drain) device, such that the  $\overline{\text{SHDN/SS}}$  input is grounded for shutdown mode, and open-circuited for normal operation (Figure 3-3a). If a CMOS device is used to control shutdown (Figure 3-3b), the value of  $R1$  and  $C_{\text{SS}}$  should be chosen such that the voltage on  $\overline{\text{SHDN/SS}}$  rises from ground to  $0.65\text{V}$  in  $1.5\text{msec}$  (Figure 3-4). If shutdown is not used,  $C_{\text{SS}}$  must still be connected as shown in Figure 3-3c and Figure 3-3d.  $\overline{\text{SHDN/SS}}$  may be pulled up with a resistor (Figure 3-3c) as long as the values of  $R_{\text{SS}}$  and  $C_{\text{SS}}$  provide the approximate charging characteristic on power up shown in Figure 3-4.  $C_{\text{SS}}$  only may also be connected as shown in Figure 3-3d with  $C_{\text{SS}}$  chosen at  $4700\text{pF}$  (minimum  $100\text{pF}$ ).

## 3.7 Undervoltage Lockout (UVLO)

The TC120 is disabled whenever  $V_{\text{IN}}$  is below the undervoltage lockout threshold. This threshold is equal to the guaranteed minimum operating voltage for the TC120 (i.e.,  $2.2\text{V}$ ). When UVLO is active, the TC120 is completely disabled.

## 3.8 Short Circuit Protection

Upon detection of an output short circuit condition, the TC120 reduces the PWM duty cycle to a minimum value using its internal protection timer. The sequence of events is as follows: when an output voltage decrease to near zero is detected (as the result of an overload), the internal ( $5\text{msec}$ ) protection timer is started. If the output voltage has not recovered to nominal value prior to the expiration of the protection timer, the TC120 is momentarily shut down by dedicated, internal circuitry. Immediately following this action, the soft start sequence is engaged in an attempt to re-start the TC120. If the output short circuit is removed, normal operation is automatically restored. If the short circuit is still present, the timed self-shutdown sequence described above is repeated.

## 3.9 External Switching Transistor Selection

EXT is a complimentary output with a maximum ON resistances of  $32\Omega$  to  $V_{\text{DD}}$  when high and  $26\Omega$  to ground when low, at  $V_{\text{OUT}} = 5\text{V}$ . It is designed to directly drive a P-channel MOSFET (Figure 3-5). The P-channel MOSFET selection is determined mainly by the on-resistance, gate-source threshold and gate charge requirements. Also, the drain-to-source and gate-to-source breakdown voltage ratings must be greater than  $V_{\text{INMAX}}$ . The total gate charge specification should be less than  $100\text{nC}$  for best efficiency. The MOSFET must be capable of handling the required peak inductor current, and should have a very low on-resistance at that current. For example, a Si9430 MOSFET has a drain-to-source rating of  $-20\text{V}$ , and a typical on-resistance  $r_{\text{DS(ON)}}$  of  $0.07\Omega$  at  $2\text{A}$ , with  $V_{\text{GS}} = -4.5\text{V}$ . (EXTW (Figure 3-6) may be gated with external circuitry to add blanking, or as an auxiliary timing signal.) Table 3-1 lists suggested components and suppliers.

## 3.10 Board Layout Guidelines

As with all inductive switching regulators, the TC120 generates fast switching waveforms, which radiate noise. Interconnecting lead lengths should be minimized to keep stray capacitance, trace resistance and radiated noise as low as possible. In addition, the GND pin, input bypass capacitor and output filter capacitor ground leads should be connected to a single point. The input capacitor should be placed as close to power and ground pins of the TC120 as possible. The length of the EXT trace must also be kept as short as possible.

**TABLE 3-1: SUGGESTED COMPONENTS AND SUPPLIERS**

Type	Inductors	Capacitors	Diodes	Transistors
<b>Surface Mount</b>	Sumida CD54 Series CDRH Series  Coilcraft DO Series	AVX TPS Series  Sprague 595D Series	ON Semiconductor MBRS340T3  Nihon NSQ Series  Matsushita MA737	Silconix Little Foot MOSFET Series  Zetex FZT749 PNP Bipolar Transistor  Toshiba 2SA1213 PNP Transistor
<b>Miniature Through-Hole</b>	Sumida RCH Series	Sanyo OS-CON Series	IRC OAR Series	
<b>Standard Through-Hole</b>	Coilcraft PCH Series	Nichicon PL Series  United Chemi-Conv LXF Series		ON Semiconductor TMOS Power MOSFETs

**FIGURE 3-2: TC120 WITH ADDED COMPONENTS FOR IMPROVED EFFICIENCY AT HIGH OUTPUT CURRENTS**

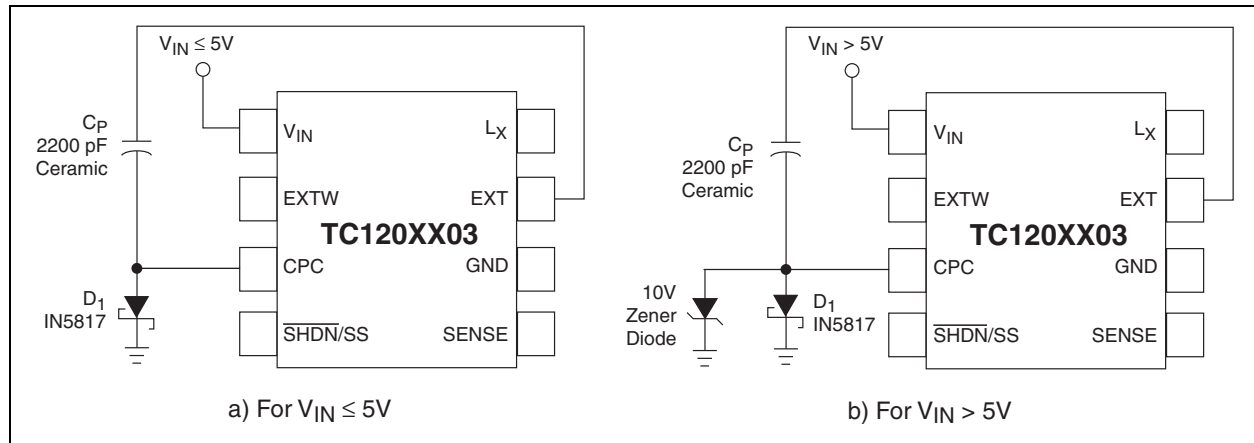

**FIGURE 3-3: SHUTDOWN CONTROL CIRCUITS**

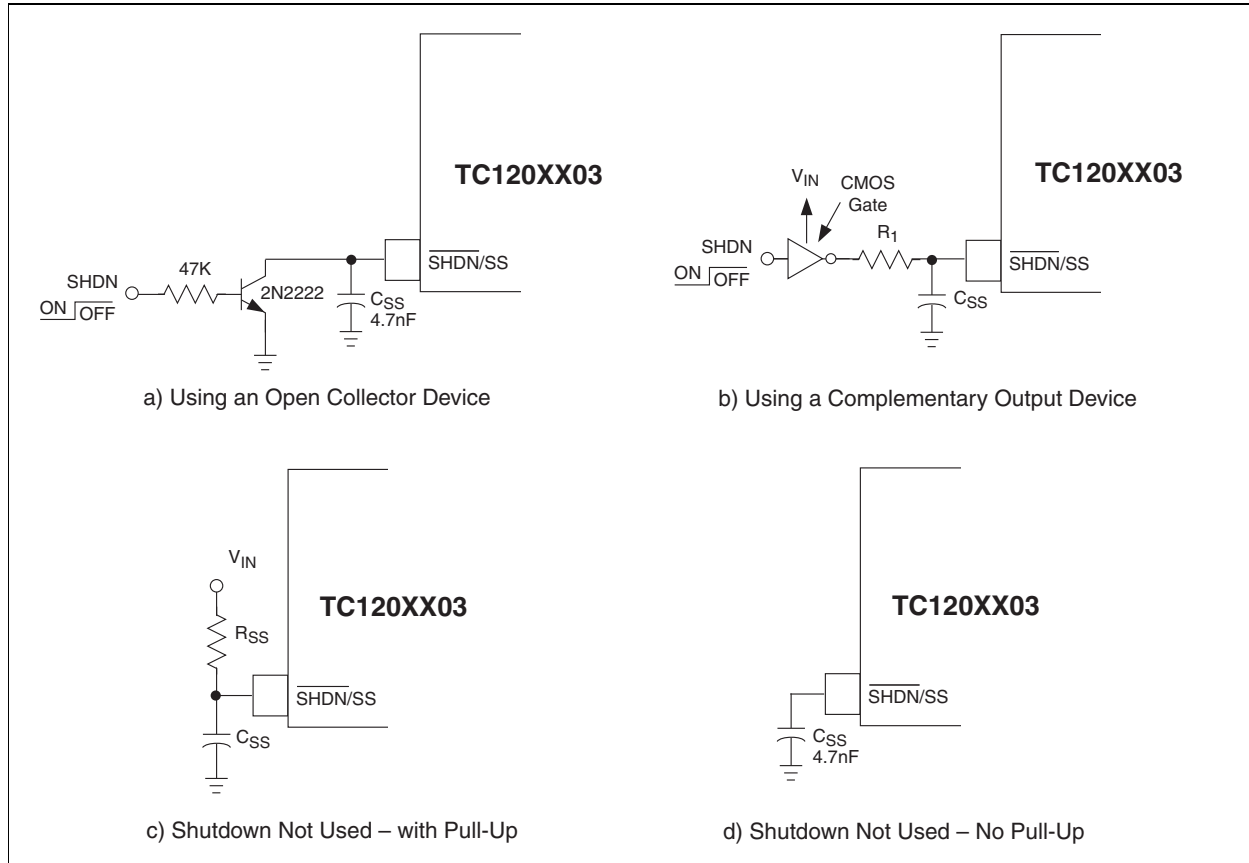

**FIGURE 3-4: SOFT START TIMING**

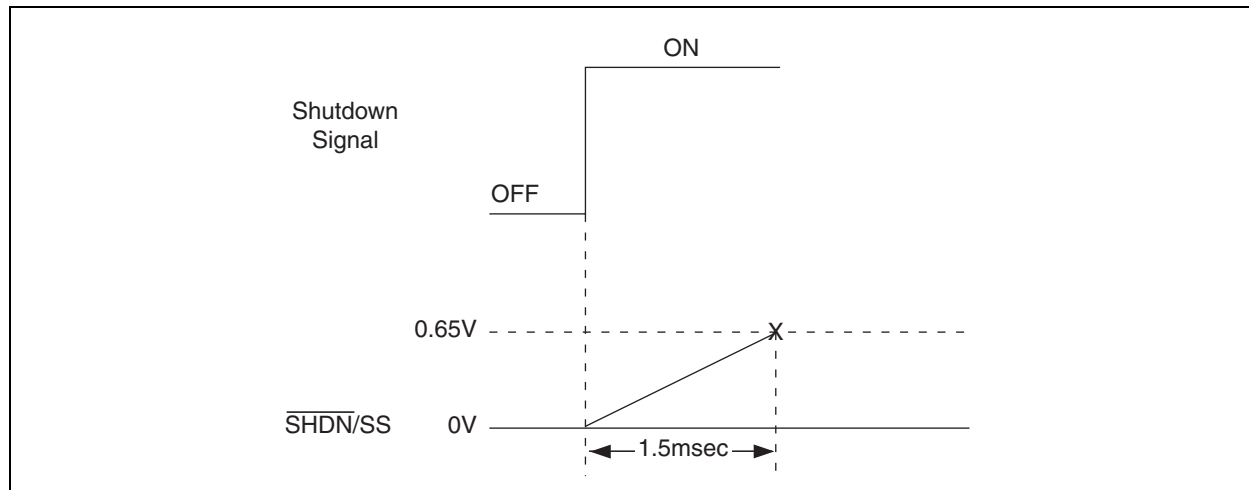

**FIGURE 3-5: USING EXTERNAL TRANSISTOR SWITCH**

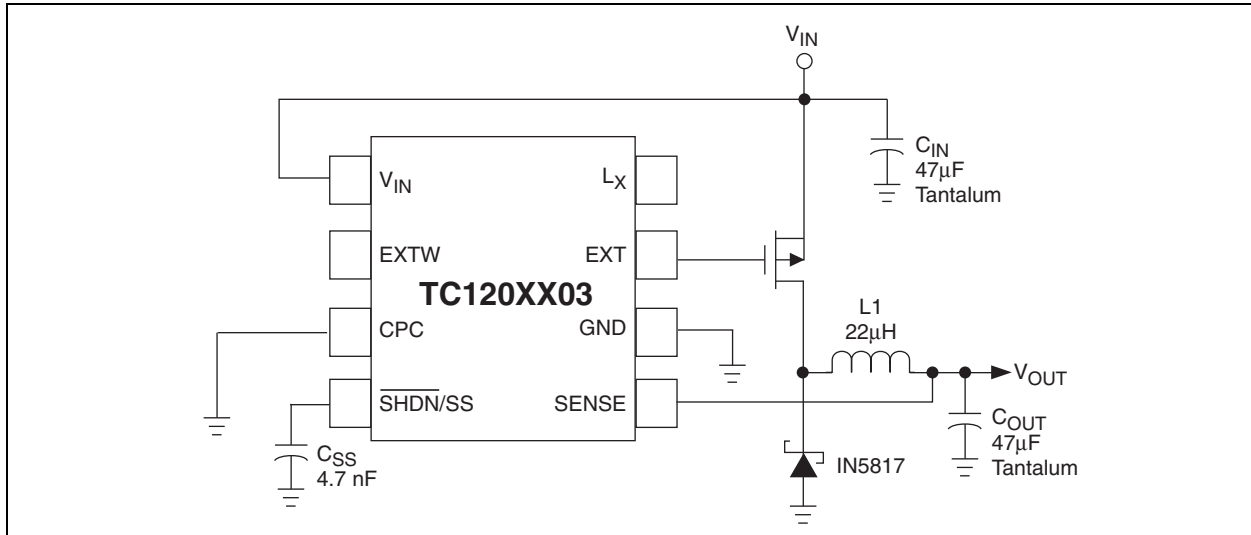

**FIGURE 3-6: EXTERNAL (EXT) AND EXTENDED EXTERNAL (EXTW) SWITCHING TRANSISTOR DRIVE OUTPUT**

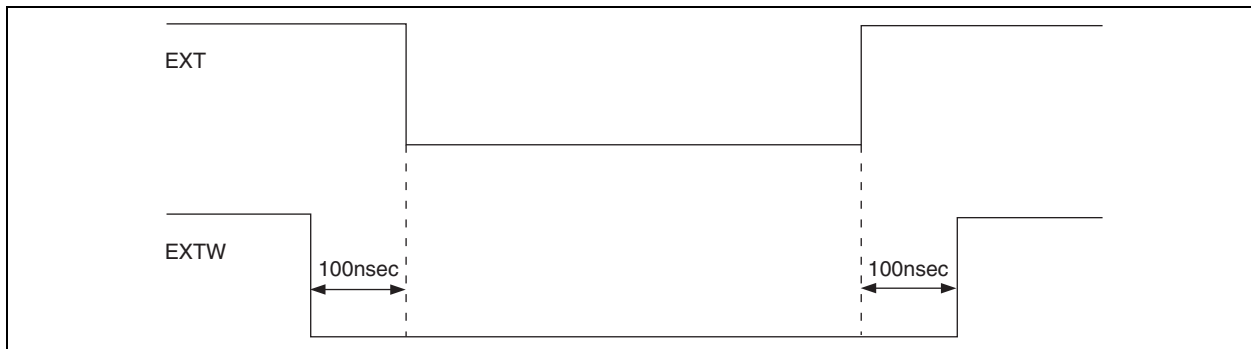

# TC120

## 4.0 PACKAGING INFORMATION

### 4.1 Package Marking Information

Package marking data not available at this time.

### 4.2 Taping Form

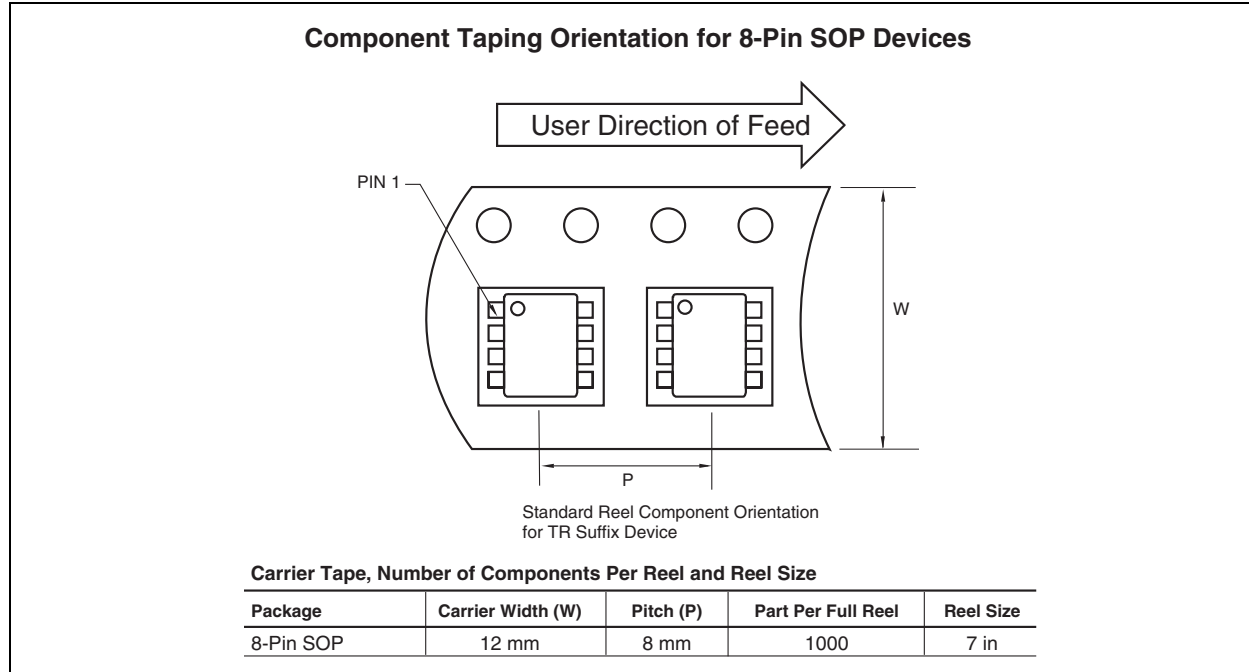

### 4.3 Package Dimensions

**Note:** For the most current package drawings, please see the Microchip Packaging Specification located at <http://www.microchip.com/packaging>

#### 8-Pin SOP

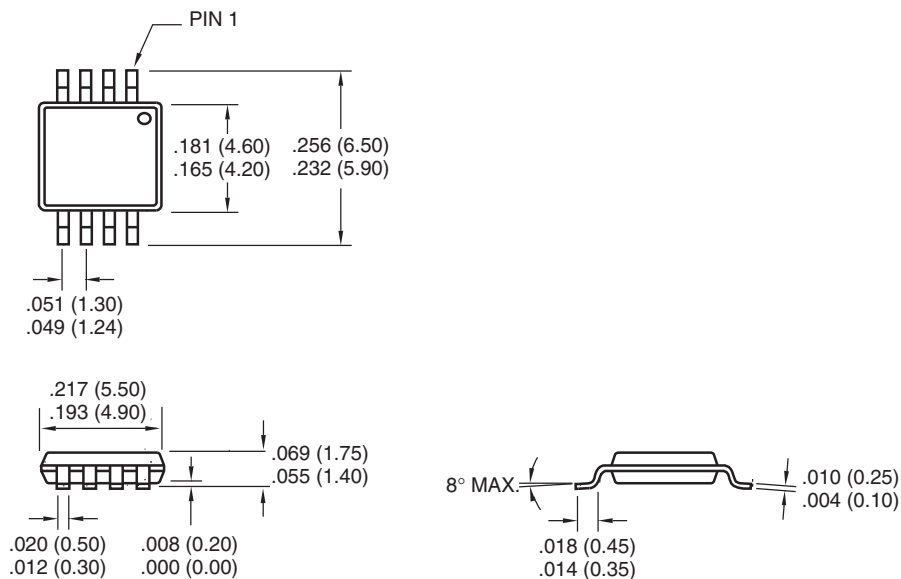

Dimensions: inches (mm)

## 5.0 REVISION HISTORY

### Revision C (November 2012)

Added a note to the package outline drawing.

# TC120

---

---

NOTES:

## **Sales and Support**

### **Data Sheets**

Products supported by a preliminary Data Sheet may have an errata sheet describing minor operational differences and recommended workarounds. To determine if an errata sheet exists for a particular device, please contact one of the following:

1. Your local Microchip sales office
2. The Microchip Worldwide Site ([www.microchip.com](http://www.microchip.com))

Please specify which device, revision of silicon and Data Sheet (include Literature #) you are using.

### **New Customer Notification System**

Register on our web site ([www.microchip.com/cn](http://www.microchip.com/cn)) to receive the most current information on our products.

# TC120

---

---

NOTES:

---

**Note the following details of the code protection feature on Microchip devices:**

- Microchip products meet the specification contained in their particular Microchip Data Sheet.
- Microchip believes that its family of products is one of the most secure families of its kind on the market today, when used in the intended manner and under normal conditions.
- There are dishonest and possibly illegal methods used to breach the code protection feature. All of these methods, to our knowledge, require using the Microchip products in a manner outside the operating specifications contained in Microchip's Data Sheets. Most likely, the person doing so is engaged in theft of intellectual property.
- Microchip is willing to work with the customer who is concerned about the integrity of their code.
- Neither Microchip nor any other semiconductor manufacturer can guarantee the security of their code. Code protection does not mean that we are guaranteeing the product as “unbreakable.”

Code protection is constantly evolving. We at Microchip are committed to continuously improving the code protection features of our products. Attempts to break Microchip's code protection feature may be a violation of the Digital Millennium Copyright Act. If such acts allow unauthorized access to your software or other copyrighted work, you may have a right to sue for relief under that Act.

---

Information contained in this publication regarding device applications and the like is provided only for your convenience and may be superseded by updates. It is your responsibility to ensure that your application meets with your specifications. MICROCHIP MAKES NO REPRESENTATIONS OR WARRANTIES OF ANY KIND WHETHER EXPRESS OR IMPLIED, WRITTEN OR ORAL, STATUTORY OR OTHERWISE, RELATED TO THE INFORMATION, INCLUDING BUT NOT LIMITED TO ITS CONDITION, QUALITY, PERFORMANCE, MERCHANTABILITY OR FITNESS FOR PURPOSE. Microchip disclaims all liability arising from this information and its use. Use of Microchip devices in life support and/or safety applications is entirely at the buyer's risk, and the buyer agrees to defend, indemnify and hold harmless Microchip from any and all damages, claims, suits, or expenses resulting from such use. No licenses are conveyed, implicitly or otherwise, under any Microchip intellectual property rights.

#### **Trademarks**

The Microchip name and logo, the Microchip logo, dsPIC, FlashFlex, KEELOQ, KEELOQ logo, MPLAB, PIC, PICmicro, PICSTART, PIC<sup>32</sup> logo, rPIC, SST, SST Logo, SuperFlash and UNI/O are registered trademarks of Microchip Technology Incorporated in the U.S.A. and other countries.

FilterLab, Hampshire, HI-TECH C, Linear Active Thermistor, MTP, SEEVAL and The Embedded Control Solutions Company are registered trademarks of Microchip Technology Incorporated in the U.S.A.

Silicon Storage Technology is a registered trademark of Microchip Technology Inc. in other countries.

Analog-for-the-Digital Age, Application Maestro, BodyCom, chipKIT, chipKIT logo, CodeGuard, dsPICDEM, dsPICDEM.net, dsPICworks, dsSPEAK, ECAN, ECONOMONITOR, FanSense, HI-TIDE, In-Circuit Serial Programming, ICSP, Mindi, MiWi, MPASM, MPF, MPLAB Certified logo, MPLIB, MPLINK, mTouch, Omniclient Code Generation, PICC, PICC-18, PICDEM, PICDEM.net, PICkit, PICtail, REAL ICE, rLAB, Select Mode, SQI, Serial Quad I/O, Total Endurance, TSHARC, UniWinDriver, WiperLock, ZENA and Z-Scale are trademarks of Microchip Technology Incorporated in the U.S.A. and other countries.

SQTP is a service mark of Microchip Technology Incorporated in the U.S.A.

GestIC and ULPP are registered trademarks of Microchip Technology Germany II GmbH & Co. & KG, a subsidiary of Microchip Technology Inc., in other countries.

All other trademarks mentioned herein are property of their respective companies.

© 2001-2012, Microchip Technology Incorporated, Printed in the U.S.A., All Rights Reserved.

 Printed on recycled paper.

ISBN: 9781620767498

**QUALITY MANAGEMENT SYSTEM**  
**CERTIFIED BY DNV**  
**== ISO/TS 16949 ==**

*Microchip received ISO/TS-16949:2009 certification for its worldwide headquarters, design and wafer fabrication facilities in Chandler and Tempe, Arizona; Gresham, Oregon and design centers in California and India. The Company's quality system processes and procedures are for its PIC<sup>®</sup> MCUs and dsPIC<sup>®</sup> DSCs, KEELOQ<sup>®</sup> code hopping devices, Serial EEPROMs, microperipherals, nonvolatile memory and analog products. In addition, Microchip's quality system for the design and manufacture of development systems is ISO 9001:2000 certified.*



# MICROCHIP

## Worldwide Sales and Service

### AMERICAS

**Corporate Office**  
2355 West Chandler Blvd.  
Chandler, AZ 85224-6199  
Tel: 480-792-7200  
Fax: 480-792-7277  
Technical Support:  
<http://www.microchip.com/support>  
Web Address:  
[www.microchip.com](http://www.microchip.com)

**Atlanta**  
Duluth, GA  
Tel: 678-957-9614  
Fax: 678-957-1455

**Boston**  
Westborough, MA  
Tel: 774-760-0087  
Fax: 774-760-0088

**Chicago**  
Itasca, IL  
Tel: 630-285-0071  
Fax: 630-285-0075

**Cleveland**  
Independence, OH  
Tel: 216-447-0464  
Fax: 216-447-0643

**Dallas**  
Addison, TX  
Tel: 972-818-7423  
Fax: 972-818-2924

**Detroit**  
Farmington Hills, MI  
Tel: 248-538-2250  
Fax: 248-538-2260

**Indianapolis**  
Noblesville, IN  
Tel: 317-773-8323  
Fax: 317-773-5453

**Los Angeles**  
Mission Viejo, CA  
Tel: 949-462-9523  
Fax: 949-462-9608

**Santa Clara**  
Santa Clara, CA  
Tel: 408-961-6444  
Fax: 408-961-6445

**Toronto**  
Mississauga, Ontario,  
Canada  
Tel: 905-673-0699  
Fax: 905-673-6509

### ASIA/PACIFIC

**Asia Pacific Office**  
Suites 3707-14, 37th Floor  
Tower 6, The Gateway  
Harbour City, Kowloon  
Hong Kong  
Tel: 852-2401-1200  
Fax: 852-2401-3431

**Australia - Sydney**  
Tel: 61-2-9868-6733  
Fax: 61-2-9868-6755

**China - Beijing**  
Tel: 86-10-8569-7000  
Fax: 86-10-8528-2104

**China - Chengdu**  
Tel: 86-28-8665-5511  
Fax: 86-28-8665-7889

**China - Chongqing**  
Tel: 86-23-8980-9588  
Fax: 86-23-8980-9500

**China - Hangzhou**  
Tel: 86-571-2819-3187  
Fax: 86-571-2819-3189

**China - Hong Kong SAR**  
Tel: 852-2401-1200  
Fax: 852-2401-3431

**China - Nanjing**  
Tel: 86-25-8473-2460  
Fax: 86-25-8473-2470

**China - Qingdao**  
Tel: 86-532-8502-7355  
Fax: 86-532-8502-7205

**China - Shanghai**  
Tel: 86-21-5407-5533  
Fax: 86-21-5407-5066

**China - Shenyang**  
Tel: 86-24-2334-2829  
Fax: 86-24-2334-2393

**China - Shenzhen**  
Tel: 86-755-8203-2660  
Fax: 86-755-8203-1760

**China - Wuhan**  
Tel: 86-27-5980-5300  
Fax: 86-27-5980-5118

**China - Xian**  
Tel: 86-29-8833-7252  
Fax: 86-29-8833-7256

**China - Xiamen**  
Tel: 86-592-2388138  
Fax: 86-592-2388130

**China - Zhuhai**  
Tel: 86-756-3210040  
Fax: 86-756-3210049

### ASIA/PACIFIC

**India - Bangalore**  
Tel: 91-80-3090-4444  
Fax: 91-80-3090-4123

**India - New Delhi**  
Tel: 91-11-4160-8631  
Fax: 91-11-4160-8632

**India - Pune**  
Tel: 91-20-2566-1512  
Fax: 91-20-2566-1513

**Japan - Osaka**  
Tel: 81-66-152-7160  
Fax: 81-66-152-9310

**Japan - Yokohama**  
Tel: 81-45-471-6166  
Fax: 81-45-471-6122

**Korea - Daegu**  
Tel: 82-53-744-4301  
Fax: 82-53-744-4302

**Korea - Seoul**  
Tel: 82-2-554-7200  
Fax: 82-2-558-5932 or  
82-2-558-5934

**Malaysia - Kuala Lumpur**  
Tel: 60-3-6201-9857  
Fax: 60-3-6201-9859

**Malaysia - Penang**  
Tel: 60-4-227-8870  
Fax: 60-4-227-4068

**Philippines - Manila**  
Tel: 63-2-634-9065  
Fax: 63-2-634-9069

**Singapore**  
Tel: 65-6334-8870  
Fax: 65-6334-8850

**Taiwan - Hsin Chu**  
Tel: 886-3-5778-366  
Fax: 886-3-5770-955

**Taiwan - Kaohsiung**  
Tel: 886-7-213-7828  
Fax: 886-7-330-9305

**Taiwan - Taipei**  
Tel: 886-2-2508-8600  
Fax: 886-2-2508-0102

**Thailand - Bangkok**  
Tel: 66-2-694-1351  
Fax: 66-2-694-1350

### EUROPE

**Austria - Wels**  
Tel: 43-7242-2244-39  
Fax: 43-7242-2244-393

**Denmark - Copenhagen**  
Tel: 45-4450-2828  
Fax: 45-4485-2829

**France - Paris**  
Tel: 33-1-69-53-63-20  
Fax: 33-1-69-30-90-79

**Germany - Munich**  
Tel: 49-89-627-144-0  
Fax: 49-89-627-144-44

**Italy - Milan**  
Tel: 39-0331-742611  
Fax: 39-0331-466781

**Netherlands - Drunen**  
Tel: 31-416-690399  
Fax: 31-416-690340

**Spain - Madrid**  
Tel: 34-91-708-08-90  
Fax: 34-91-708-08-91

**UK - Wokingham**  
Tel: 44-118-921-5869  
Fax: 44-118-921-5820

10/26/12

## Looking for pricing, stock, or lifecycle information?

Click below to explore more details on WIN SOURCE:

 [View TC120503EHATR on WIN SOURCE](#)

 [Microchip Technology](#) Information

## Optimize Your Supply Chain with WIN SOURCE Solutions

-  Global Sourcing Solution
-  Obsolete Management
-  Cost Control Management
-  Shortage Management
-  Alternative Solution
-  Excess Inventory Management