



THE DATASHEET OF TSM1NB60CW RPG



N-Channel Power MOSFET

600V, 1A, 10Ω

FEATURES

- Advanced planar process
- 100% avalanche tested
- Low $R_{DS(ON)}$ 8Ω (Typ.)
- Low gate charge typical @ 6.1 nC (Typ.)
- Low Crss typical @4.2pF (Typ.)

KEY PERFORMANCE PARAMETERS

PARAMETER	VALUE	UNIT
V_{DS}	600	V
$R_{DS(on)}$ (max)	10	Ω
Q_g	6.1	nC

APPLICATION

- Power Supply
- Lighting
- Charger

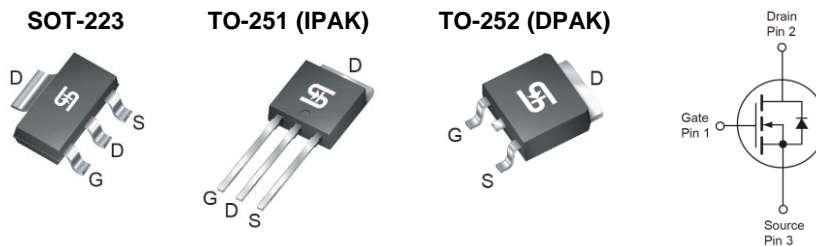

Notes: MSL 3 (Moisture Sensitivity Level) for TO-252 (D-PAK), SOT-223 per J-STD-020

ABSOLUTE MAXIMUM RATINGS ($T_A = 25^\circ\text{C}$ unless otherwise noted)

PARAMETER	SYMBOL	IPAK/DPAK	SOT-223	UNIT
Drain-Source Voltage	V_{DS}	600		V
Gate-Source Voltage	V_{GS}	±30		V
Continuous Drain Current ^(Note 1)	I_D	$T_C = 25^\circ\text{C}$		A
		$T_C = 100^\circ\text{C}$		
Pulsed Drain Current ^(Note 2)	I_{DM}	4		A
Total Power Dissipation @ $T_C = 25^\circ\text{C}$	P_{DTOT}	39	2.1	W
Single Pulsed Avalanche Energy ^(Note 3)	E_{AS}	5		mJ
Single Pulsed Avalanche Current ^(Note 3)	I_{AS}	1		A
Peak Diode Recovery dv/dt ^(Note 4)	dv/dt	4.5		V/ns
Operating Junction and Storage Temperature Range	T_J, T_{STG}	- 55 to +150		°C

THERMAL PERFORMANCE

PARAMETER	SYMBOL	IPAK/DPAK	SOT-223	UNIT
Junction to Case Thermal Resistance	$R_{\theta JC}$	2.87	--	°C/W
Junction to Ambient Thermal Resistance	$R_{\theta JA}$	110	60	°C/W

Notes: $R_{\theta JA}$ is the sum of the junction-to-case and case-to-ambient thermal resistances. The case thermal reference is defined at the solder mounting surface of the drain pins. $R_{\theta JA}$ is guaranteed by design while $R_{\theta CA}$ is determined by the user's board design. $R_{\theta JA}$ shown below for single device operation on FR-4 PCB in still air.

ELECTRICAL SPECIFICATIONS ($T_A = 25^\circ\text{C}$ unless otherwise noted)						
PARAMETER	CONDITIONS	SYMBOL	MIN	TYP	MAX	UNIT
Static (Note 5)						
Drain-Source Breakdown Voltage	$V_{GS} = 0V, I_D = 250\mu A$	BV_{DSS}	600	--	--	V
Drain-Source On-State Resistance	$V_{GS} = 10V, I_D = 0.5A$	$R_{DS(ON)}$	--	8	10	Ω
Gate Threshold Voltage	$V_{DS} = V_{GS}, I_D = 250\mu A$	$V_{GS(TH)}$	2.5	3.5	4.5	V
Zero Gate Voltage Drain Current	$V_{DS} = 600V, V_{GS} = 0V$	I_{DSS}	--	--	10	μA
Gate Body Leakage	$V_{GS} = \pm 30V, V_{DS} = 0V$	I_{GSS}	--	--	± 100	nA
Forward Transfer Conductance	$V_{DS} = 10V, I_D = 0.5A$	g_{fs}	--	0.8	--	S
Dynamic (Note 6)						
Total Gate Charge	$V_{DS} = 480V, I_D = 1A,$ $V_{GS} = 10V$	Q_g	--	6.1	--	nC
Gate-Source Charge		Q_{gs}	--	1.4	--	
Gate-Drain Charge		Q_{gd}	--	3.3	--	
Input Capacitance	$V_{DS} = 25V, V_{GS} = 0V,$ $f = 1.0\text{MHz}$	C_{iss}	--	138	--	pF
Output Capacitance		C_{oss}	--	17.1	--	
Reverse Transfer Capacitance		C_{rss}	--	4.2	--	
Gate Resistance	$F = 1\text{MHz}, \text{open drain}$	R_g	--	12.5	--	Ω
Switching (Note 7)						
Turn-On Delay Time	$V_{DD} = 300V, R_G = 25\Omega$ $I_D = 1A, V_{GS} = 10V$	$t_{d(on)}$	--	7.7	--	ns
Turn-On Rise Time		t_r	--	6.8	--	
Turn-Off Delay Time		$t_{d(off)}$	--	15.3	--	
Turn-Off Fall Time		t_f	--	14.9	--	
Source-Drain Diode (Note 5)						
Diode Forward Voltage	$I_S = 1A, V_{GS} = 0V$	V_{SD}	--	0.9	1.4	V
Source Current	Integral reverse diode In the MOSFET	I_S	--	--	1	A
Source Current (Pulse)		I_{SM}	--	--	4	

Notes:

- Current limited by package.
- Pulse width limited by the maximum junction temperature.
- $L = 10\text{mH}, I_{AS} = 1A, V_{DD} = 50V, R_G = 25\Omega$, Starting $T_J = 25^\circ\text{C}$.
- $I_{SD} \leq 1A, V_{DD} \leq BV_{DSS}, di/dt \leq 200A/\mu s$, Starting $T_J = 25^\circ\text{C}$.
- Pulse test: $PW \leq 300\mu s$, duty cycle $\leq 2\%$.
- For DESIGN AID ONLY, not subject to production testing.
- Switching time is essentially independent of operating temperature.

ORDERING INFORMATION

PART NO.	PACKAGE	PACKING
TSM1NB60CH C5G	TO-251	75 pcs / Tube
TSM1NB60CP ROG	TO-252	2,500 pcs / 13" Reel
TSM1NB60CW RPG	SOT-223	2,500 pcs / 13" Reel

Note:

1. Compliant to RoHS Directive 2011/65/EU and in accordance to WEEE 2002/96/EC
2. Halogen-free according to IEC 61249-2-21 definition

PACKAGE OUTLINE DIMENSIONS (Unit: Millimeters)

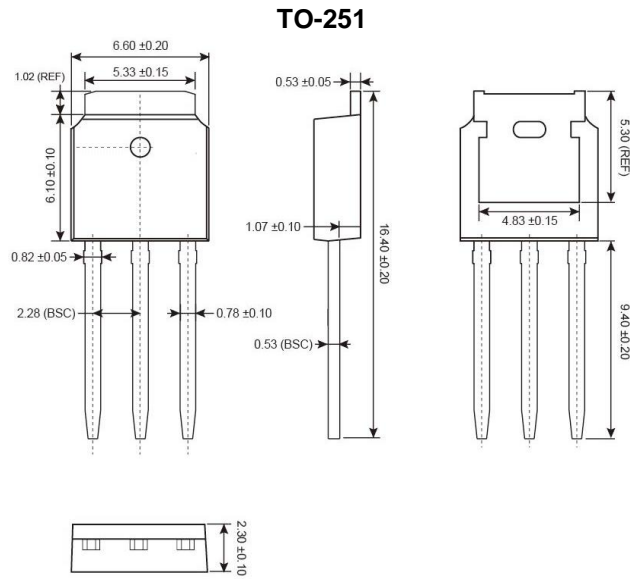

MARKING DIAGRAM

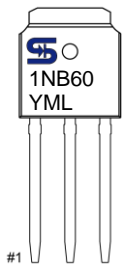

Y = Year Code

M = Month Code for Halogen Free Product

O =Jan **P** =Feb **Q** =Mar **R** =Apr

S =May **T** =Jun **U** =Jul **V** =Aug

W =Sep **X** =Oct **Y** =Nov **Z** =Dec

L = Lot Code (1~9, A~Z)

PACKAGE OUTLINE DIMENSIONS (Unit: Millimeters)

TO-252

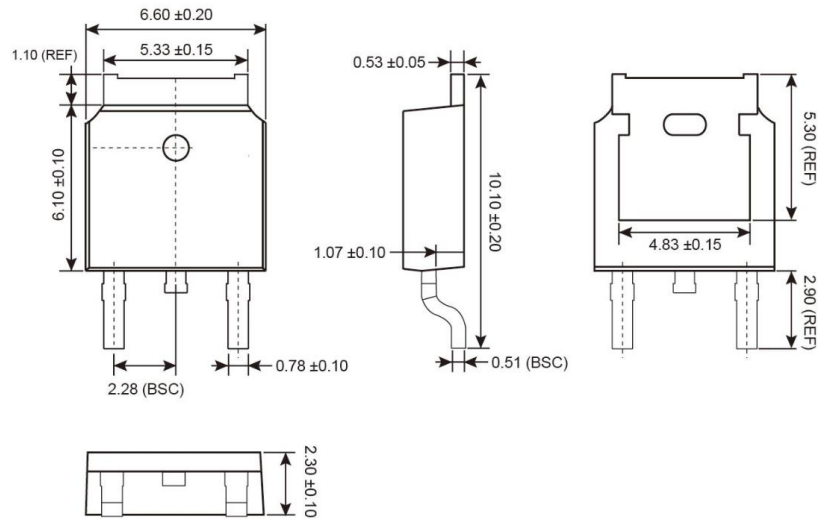

SUGGESTED PAD LAYOUT

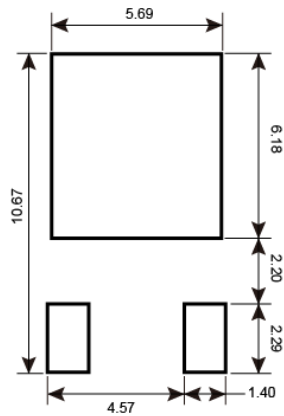

MARKING DIAGRAM

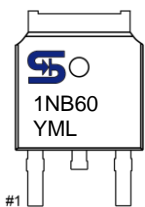

Y = Year Code

M = Month Code for Halogen Free Product

O =Jan **P** =Feb **Q** =Mar **R** =Apr

S =May **T** =Jun **U** =Jul **V** =Aug

W =Sep **X** =Oct **Y** =Nov **Z** =Dec

L = Lot Code (1~9, A~Z)

PACKAGE OUTLINE DIMENSIONS (Unit: Millimeters)

TO-252

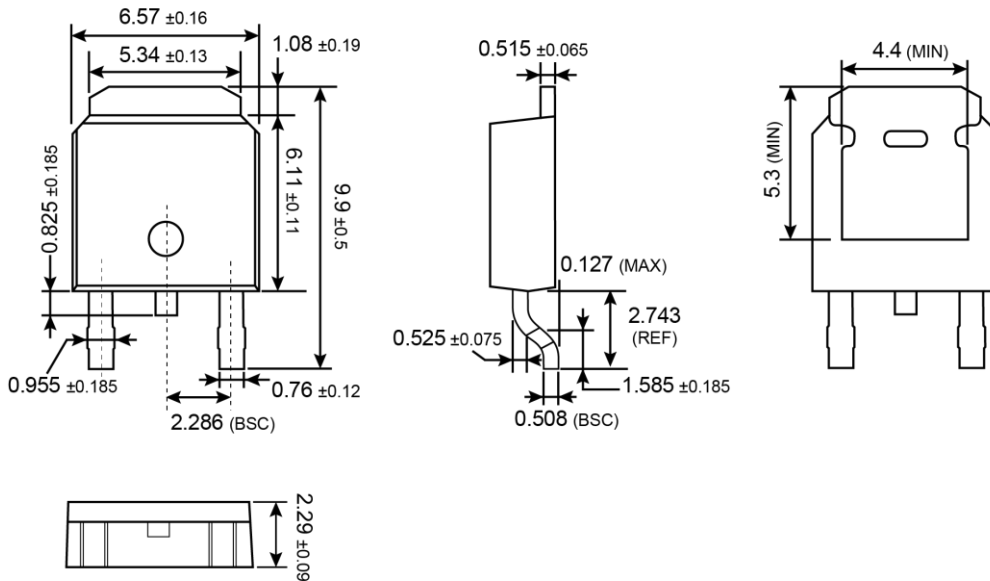

SUGGESTED PAD LAYOUT (Unit: Millimeters)

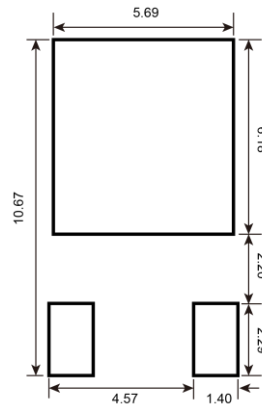

MARKING DIAGRAM



- Y** = Year Code
- M** = Month Code for Halogen Free Product
 - O** =Jan **P** =Feb **Q** =Mar **R** =Apr
 - S** =May **T** =Jun **U** =Jul **V** =Aug
 - W** =Sep **X** =Oct **Y** =Nov **Z** =Dec
- L** = Lot Code (1~9, A~Z)

PACKAGE OUTLINE DIMENSIONS (Unit: Millimeters)

SOT-223

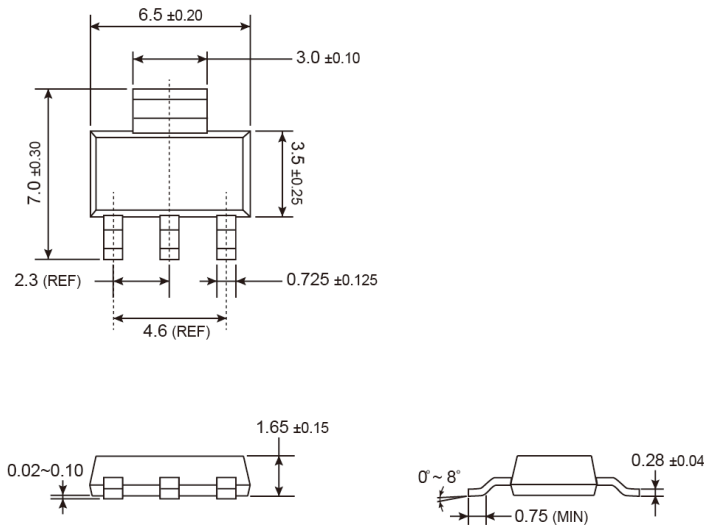

SUGGESTED PAD LAYOUT

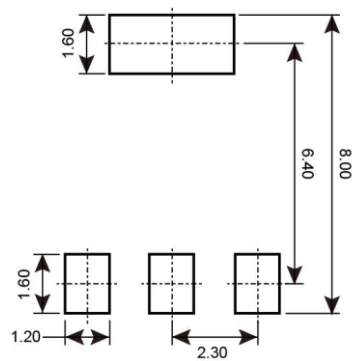

MARKING DIAGRAM

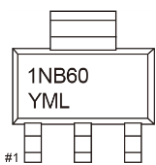

Y = Year Code
M = Month Code for Halogen Free Product
O =Jan **P** =Feb **Q** =Mar **R** =Apr
S =May **T** =Jun **U** =Jul **V** =Aug
W =Sep **X** =Oct **Y** =Nov **Z** =Dec
L = Lot Code (1~9, A~Z)

Notice

Specifications of the products displayed herein are subject to change without notice. TSC or anyone on its behalf, assumes no responsibility or liability for any errors or inaccuracies.

Information contained herein is intended to provide a product description only. No license, express or implied, to any intellectual property rights is granted by this document. Except as provided in TSC's terms and conditions of sale for such products, TSC assumes no liability whatsoever, and disclaims any express or implied warranty, relating to sale and/or use of TSC products including liability or warranties relating to fitness for a particular purpose, merchantability, or infringement of any patent, copyright, or other intellectual property right.

The products shown herein are not designed for use in medical, life-saving, or life-sustaining applications. Customers using or selling these products for use in such applications do so at their own risk and agree to fully indemnify TSC for any damages resulting from such improper use or sale.

Looking for pricing, stock, or lifecycle information?

Click below to explore more details on WIN SOURCE:

- ⊖ [View TSM1NB60CW RPG on WIN SOURCE](#)
- ⊖ [Taiwan Semiconductor](#) Information

Optimize Your Supply Chain with WIN SOURCE Solutions

- ✓ Global Sourcing Solution
- ✓ Obsolete Management
- ✓ Cost Control Management
- ✓ Shortage Management
- ✓ Alternative Solution
- ✓ Excess Inventory Management